

**TOWN OF ARLINGTON  
MASSACHUSETTS**

**Bid #15-13**

**INVITATION FOR BID**

**Stage Decking/Curtain Repair - Ottoson School**

Sealed bids are invited and will be received by the Town Manager, Town of Arlington, Massachusetts, until **11:00 A.M., Thursday, April 16, 2015** at the Office of the Purchasing Agent, Town Hall, Arlington, Massachusetts, at which time and place in the Town Hall they will be publicly opened and read aloud.

Specifications and proposal forms will be available at the Office of the Purchasing Agent/Town Manager's Office at the above-mentioned address on **Wednesday April 1, 2015** and on the Town Website [www.arlingtonma.gov/purchasing](http://www.arlingtonma.gov/purchasing).

Every bid shall be accompanied by a **BID DEPOSIT** in the form of a **BID BOND OR CASH, OR A CERTIFIED CHECK, OR TREASURER'S OR CASHIER'S CHECK**. The amount of such bid deposit shall be **FIVE PERCENT (5%)** of the value of the bid.

All bids must be in sealed envelopes plainly marked:

**BID #15-13 Stage Decking/Curtain Repair - Ottoson School**

**A Pre-bid Site Visit will be held on Tuesday April 7, 2015 @ 3:00 P.M. at the Ottoson Middle School, 63 Acton Street, Arlington, MA. Attendees to meet at the Main Entrance. All Prospective Bidders are encouraged to attend.**

Attention is called to the fact that minimum wage rates and health and welfare and pension fund contributions are established for this contract and are a part of the specifications.

Work under this contract shall be governed by MGL Ch.149, Sec.44A-J.

A Performance Bond in the amount of \$ 50% of the total dollar award is required.

A Payment Bond in the amount of \$ 50% of the total dollar award is required.

The conditions of employment as set forth in Sections 26 to 27D and 27F of Chapter 149 of the General Laws, as amended, shall prevail in the execution of the work under this contract.

Bids to receive consideration must be in the hands of the Purchasing Agent or his authorized representative not later than the day and hour above mentioned.

For further information relative to this bid, please confer with Mark Miano at 781-316-3631.

The Town Manager reserves the right to cancel any invitation for bids, to reject in whole or in part any and all bids, when it is deemed in the best interest of the Town of Arlington to do so.

TOWN OF ARLINGTON

Adam W. Chapdelaine  
Town Manager

April 1, 2015

**BID PROPOSAL FORM**

BID #15-13

PROJECT: Stage Decking/Curtain Repair - Ottoson School  
63 Acton Street  
Arlington, MA 02476

DATE: THURSDAY APRIL 16, 2015 @ 11:00 A.M.

Pursuant to and in compliance with the proposed Contract Documents dated April 1, 2015 relating to the above referenced project, the undersigned, hereby proposes and agrees to furnish all labor and materials and perform all work within the time stated and in strict accordance with the proposed Contract Documents, and addenda thereto, for Stage Decking/Curtain Repair - Ottoson School as follows:

1. Stage Decking/Curtain Repair - Ottoson School

All labor services, miscellaneous materials, tools, equipment and supervision necessary for the Completion of the entire project as stated in the Specifications, or properly inferable there from, all in accordance with the Contract Documents.

ADDENDA: \_\_\_\_\_

The Proposed Contract Price :

\$ \_\_\_\_\_ TOTAL BID PRICE

FIRM NAME \_\_\_\_\_

ADDRESS \_\_\_\_\_

\_\_\_\_\_

PHONE NO. \_\_\_\_\_

FAX NO. \_\_\_\_\_

AUTHORIZED SIGNATURE \_\_\_\_\_

PRINT AUTHORIZED NAME \_\_\_\_\_

## CERTIFICATE OF NON-COLLUSION

The undersigned certifies under penalties of perjury that this bid or proposal has been made and submitted in good faith and without collusion or fraud with any other person. As used in this certification, the word "person" shall mean any natural person, business, partnership, corporation, union, committee, club or other organization, entity, or group of individuals.

---

(Signature of individual submitting bid or proposal)

---

(Name of individual submitting bid or proposal)

---

Name of Business

---

Date

---

Pursuant to M.G.L. Chapter 62C, Section 49A, I certify under the penalties of perjury that I have complied with all laws of the commonwealth relating to taxes, reporting of employees and contractors, and withholding and remitting child support.

---

Social Security Number or  
Federal Identification Number

---

Signature of Individual or Responsible  
Corporate Officer and Title

**NON-COLLUSION FORMS**  
**MUST BE SIGNED AND**  
**SUBMITTED WITH BID**

**OSHA TRAINING**

The undersigned hereby certifies that it is able to furnish labor that can work in harmony with all other elements of labor employed or to be employed on the work; that all employees to be employed at the worksite will have successfully completed a course in construction safety and health approved by the United States Occupational Safety and Health Administration that is at least 10 hours in duration at the time the employee begins work and who shall furnish documentation of successful completion of said course with the first certified payroll report for each employee; and that it will comply fully with all laws and regulations applicable to awards made subject to section forty-four A of Chapter 149 of the General Laws.

---

Signature: \_\_\_\_\_

Title: \_\_\_\_\_

Date: \_\_\_\_\_

We are looking to have the following work done on our stage at Ottoson Middle School:

- Stage decking for c. 23' X 78' including installation & painting
- Main traveler and valence, using existing Traveler Track  
16' X 48' Traveler  
5' X 48' Valence
- 1 Masking Package  
1 Full Black (traveler) 16' X 48'  
2 borders 4' X 50'  
4 Legs 7' X 16'
- 1 New Upstage Cyc on a new DH pipe  
Seamless white muslin w/pipe pocket 16' X 48'

## 1/4" Tempered Premium Hardboard

Property	Minimum/Maximum	Average Value
Modulus of Rupture (MOR)	≥4300 psi	4500 psi
Internal Bond (PTS)	≥70 psi	90 psi
24 hr. Thickness Increase (TI)	≤30%	20%
Density (lbs./ft <sup>3</sup> )		54
Moisture Content		3-5%
Formaldehyde Emissions		<.1 ppm



## Technical Service Bulletin

This document pertains to Decorative Panels International products only. Our manufacturing practices at times are confused with those in other engineered wood products such as MDF (medium density fiberboard) or PB (particleboard). This bulletin provides clarification on those questions that are often asked and documents our manufacturing process for distributors, converters and retailers.

**DPI** hardboard is manufactured following the guidelines established within American National Standards Institute 135.4-2004 Basic Hardboard Standard. **DPI** hardboard is made using wet formed processing of mixed North American hardwoods, agricultural oil and bonded under the application of heat and pressure in a stationary press.

**DPI** wall paneling products are manufactured following the guidelines established within American National Standards Institute 135.5-2004 Prefinished Hardboard Paneling Standards. The hardboard is painted and all coatings are either acrylic latex or alkyd enamel depending on the class of panel requirements and desired performance levels.

**DPI** Flame spread testing is accomplished according to the ASTM E-84 Test Method for Determining Surface Burning Characteristics of Building Materials. **All *DPI Prefinished hardboard wall paneling products* are rated as Class C (or Class III) in this test.**

**DPI** hardboard and prefinished hardboard wall paneling products are made entirely of wood fibers and contain no asbestos in any form.

**DPI** hardboard and prefinished hardboard wall paneling products are manufactured without the use of phthalates in any of its processes.

**DPI** hardboard and prefinished hardboard wall paneling products are bonded using heat and pressure. **DPI** hardboard and **DPI** hardboard wall paneling are naturally bonded by the lignin found in wood pulp fibers. ***DPI does not add urea formaldehyde binding agents to our family of products.*** By nature of its formulation, its process and compliance with ANSI 135.4 and ANSI 135.5, **DPI** Hardboard and Prefinished Wall Panel Products are compliant and also exempt from all California Air Resource Board (CARB) ATCM for Urea Formaldehyde Emissions. All **DPI** Hardboard products, Tempered and Standard meet or exceed CARB I and CARB II requirements.

**DPI** hardboard and prefinished hardboard wall paneling products do not contain lead. Our coatings and finishes do not contain lead in any form nor is lead a part of any formulation used in our manufacturing processes.

Timothy R. Boerst  
Director, Industrial and International Markets  
Decorative Panels International (DPI)  
2900 Hill Avenue  
Toledo, Ohio 43607-2929 USA  
Phone: 1-800-521-4301 (Toll Free)  
Phone: 1-419-535-5921 (Direct)

# Material Safety Data Sheet

Issuing Date 06-Dec-2010

Revision Date

Revision Number 0

## 1. PRODUCT AND COMPANY IDENTIFICATION

**Product Name** Industrial Panels  
**Recommended Use** Interior wall panels  
**Synonyms** Hardboard panels

**Supplier Address**  
Decorative Panels International  
2900 Hill Avenue  
Toledo, Ohio  
43607-2929  
TEL: 419-535-5921

**Emergency Telephone Number** 1-800-521-4301

## 2. HAZARDS IDENTIFICATION

### Emergency Overview

Contact with strong oxidizers or exposures to temperatures greater than 400°F (204.4°C) may cause a fire.  
Airborne wood and resin dust may explode when combined with an ignition source.  
Smoke may contain carbon monoxides, aldehydes, and other toxic materials.  
Cancer hazard  
WARNING! This product contains a chemical known in the State of California to cause cancer.

**Appearance** No information available      **Physical State** Solid.      **Odor** None, Very slight

### Potential Health Effects

**Principle Routes of Exposure** Eye contact. Skin contact. Inhalation.

### Acute Toxicity

**Eyes** May cause slight irritation.  
**Skin** May cause irritation.  
**Inhalation** Irritating to respiratory system.  
**Ingestion** No known effect based on information supplied.

### Chronic Effects

Wood dust has been classified by the International Agency for Research on Cancer (IARC) as a known human carcinogen (Group 1)

### Aggravated Medical Conditions

Pre-existing eye disorders. Skin disorders. Respiratory disorders.

### Environmental Hazard

See Section 12 for additional Ecological Information.

## 3. COMPOSITION/INFORMATION ON INGREDIENTS

Chemical Name	CAS-No	Weight %
Wood dust	Proprietary	60-100
Linseed oil	8001-26-1	1-5
Solvent naphtha (petroleum), medium aliphatic	64742-88-7	<0.1
Methyl ethyl ketoxime	96-29-7	<0.1



Zirconium ethyl hexoate	22464-99-9	<0.1
Cobalt neodecanoate	27253-31-2	<0.1
Hexanoic acid, 2-ethyl-, cobalt(2+) salt	136-52-7	<0.1

#### 4. FIRST AID MEASURES

<b>Eye Contact</b>	Rinse immediately with plenty of water, also under the eyelids, for at least 15 minutes. If irritation persists, call a physician.
<b>Skin Contact</b>	Wash off with warm water and soap. If skin irritation persists, call a physician.
<b>Inhalation</b>	Move to fresh air. Consult a physician.
<b>Ingestion</b>	Consult a physician.
<b>Notes to Physician</b>	Treat symptomatically.

#### 5. FIRE-FIGHTING MEASURES

<b>Flammable Properties</b>	Combustible material. Dust can form an explosive mixture in air.
<b>Flash Point</b>	Not determined.
<b>Suitable Extinguishing Media</b>	Water. Dry chemical.
<b>Explosion Data</b>	None
<b>Sensitivity to Mechanical Impact</b>	Fine dust dispersed in air, in sufficient concentrations, and in the presence of an ignition source is a potential dust explosion hazard
<b>Sensitivity to Static Discharge</b>	
<b>Specific Hazards Arising from the Chemical</b>	Airborne concentrations of combustible dust, when combined with an ignition source, can create an explosion hazard if the dust concentration exceeds 30 - 60 g/m <sup>3</sup>
<b>Protective Equipment and Precautions for Firefighters</b>	As in any fire, wear self-contained breathing apparatus pressure-demand, MSHA/NIOSH (approved or equivalent) and full protective gear.
<b>NFPA</b>	<b>Health Hazard 1      Flammability 1      Instability 0      Physical and Chemical Hazards -</b>
<b>HMS</b>	<b>Health Hazard 1*      Flammability 1      Physical Hazard 0      Personal Protection -</b>

#### 6. ACCIDENTAL RELEASE MEASURES

<b>Personal Precautions</b>	Ensure adequate ventilation.
<b>Environmental Precautions</b>	Refer to protective measures listed in Sections 7 and 8.
<b>Methods for Containment</b>	Not applicable
<b>Methods for Cleaning Up</b>	Pick up and transfer to properly labeled containers.
<b>Other Information</b>	Not applicable.

#### 7. HANDLING AND STORAGE

<b>Handling</b>	Handle in accordance with good industrial hygiene and safety practice. Avoid contact with skin and eyes. Avoid dust formation. Wear personal protective equipment.
<b>Storage</b>	Keep containers tightly closed in a dry, cool and well-ventilated place.

## 8. EXPOSURE CONTROLS / PERSONAL PROTECTION

**Exposure Guidelines** This product does not contain any hazardous materials with occupational exposure limits established by the region specific regulatory bodies.

Chemical Name	ACGIH TLV	OSHA PEL	NIOSH IDLH
Wood dust	TWA: 1 mg/m <sup>3</sup> (inhalable fraction)	(vacated) 5 mg/m <sup>3</sup> PEL STEL: 10 mg/m <sup>3</sup>	TWA: 1 mg/m <sup>3</sup>

OSHA PEL: Occupational Safety and Health Administration - Permissible Exposure Limits. ACGIH TLV: American Conference of Governmental Industrial Hygienists - Threshold Limit Value. NIOSH IDLH: Immediately Dangerous to Life or Health.

**Other Exposure Guidelines** Vacated limits revoked by the Court of Appeals decision in AFL-CIO v. OSHA, 965 F.2d 962 (11th Cir., 1992).

**Engineering Measures** Showers  
Eyewash stations  
Ventilation systems

### Personal Protective Equipment

#### **Eye/Face Protection**

Safety glasses with side-shields.

#### **Skin and Body Protection**

Protective gloves.

#### **Respiratory Protection**

If exposure limits are exceeded or irritation is experienced, NIOSH/MSHA approved respiratory protection should be worn. Positive-pressure supplied air respirators may be required for high airborne contaminant concentrations. Respiratory protection must be provided in accordance with current local regulations.

**Hygiene Measures** Handle in accordance with good industrial hygiene and safety practice.

## 9. PHYSICAL AND CHEMICAL PROPERTIES

<b>Appearance</b>	No information available	<b>Odor</b>	None, Very slight.
<b>Odor Threshold</b>	No information available.	<b>Physical State</b>	Solid
<b>pH</b>	No information available.		
<b>Flash Point</b>	No information available.	<b>Autoignition Temperature</b>	No information available.
<b>Decomposition Temperature</b>	No information available.	<b>Boiling Point/Range</b>	No information available
<b>Melting Point/Range</b>	No information available		
<b>Flammability Limits in Air</b>	No information available.	<b>Explosion Limits</b>	No information available.
<b>Specific Gravity</b>	0.81-1.07	<b>Solubility</b>	No information available
<b>Evaporation Rate</b>	No information available	<b>Vapor Pressure</b>	No data available
<b>Vapor Density</b>	No data available		

## 10. STABILITY AND REACTIVITY

**Stability** Stable under recommended storage conditions.

**Incompatible Products** Strong oxidizing agents.

**Conditions to Avoid** Dust formation. Heat.

**Hazardous Decomposition Products** Carbon oxides. Hydrogen cyanide.

**Hazardous Polymerization** Hazardous polymerization does not occur.

## 11. TOXICOLOGICAL INFORMATION

### Acute Toxicity

**Product Information** Product does not present an acute toxicity hazard based on known or supplied information.

### Chronic Toxicity

**Chronic Toxicity** Wood dust has been classified by the International Agency for Research on Cancer (IARC) as a known human carcinogen (Group 1)

**Carcinogenicity** The table below indicates whether each agency has listed any ingredient as a carcinogen.

Chemical Name	ACGIH	IARC	NTP	OSHA
Wood dust		Group 1	Known	X
Cobalt neodecanoate		Group 2B		X
Hexanoic acid, 2-ethyl-, cobalt(2+) salt		Group 2B		X

**IARC: (International Agency for Research on Cancer)**

Group 1 - Carcinogenic to Humans  
Group 2B - Possibly Carcinogenic to Humans

**NTP: (National Toxicity Program)**

Known - Known Carcinogen

**OSHA: (Occupational Safety & Health Administration)**

X - Present

**Target Organ Effects** Respiratory system.

## 12. ECOLOGICAL INFORMATION

### Ecotoxicity

The environmental impact of this product has not been fully investigated.

Chemical Name	Toxicity to Algae	Toxicity to Fish	Toxicity to Microorganisms	Daphnia Magna (Water Flea)
Solvent naphtha (petroleum), medium aliphatic	EC50: 450 mg/L Pseudokirchneriella subcapitata 96 h	LC50: 800 mg/L Pimephales promelas 96 h static		EC50: >100 mg/L Daphnia magna 48 h
Methyl ethyl ketoxime	EC50: 83 mg/L Desmodesmus subspicatus 72 h	LC50: 777-914 mg/L Pimephales promelas 96 h flow-through LC50: 320-1000 mg/L Leuciscus idus 96 h static LC50: 760 mg/L Poecilia reticulata 96 h static	EC50 = 281 mg/L 17 h EC50 = 950 mg/L 5 min	EC50: 750 mg/L Daphnia magna 48 h

Chemical Name	Log Pow
Methyl ethyl ketoxime	0.65

### 13. DISPOSAL CONSIDERATIONS

**Waste Disposal Methods**

This material, as supplied, is not a hazardous waste according to Federal regulations (40 CFR 261). This material could become a hazardous waste if it is mixed with or otherwise comes in contact with a hazardous waste, if chemical additions are made to this material, or if the material is processed or otherwise altered. Consult 40 CFR 261 to determine whether the altered material is a hazardous waste. Consult the appropriate state, regional, or local regulations for additional requirements.

**Contaminated Packaging**

Do not re-use empty containers.

This product contains one or more substances that are listed with the State of California as a hazardous waste.

Chemical Name	California Hazardous Waste
Cobalt neodecanoate	Toxic
Hexanoic acid, 2-ethyl-, cobalt(2+) salt	Toxic

### 14. TRANSPORT INFORMATION

**DOT** Not regulated

**TDG** Not regulated

**MEX** Not regulated

### 15. REGULATORY INFORMATION

**International Inventories**

**TSCA** Complies  
**DSL** Complies

**Legend**

**TSCA** - United States Toxic Substances Control Act Section 8(b) Inventory

**DSL/NDSL** - Canadian Domestic Substances List/Non-Domestic Substances List

**U.S. Federal Regulations**

Section 313 of Title III of the Superfund Amendments and Reauthorization Act of 1986 (SARA). This product does not contain any chemicals which are subject to the reporting requirements of the Act and Title 40 of the Code of Federal Regulations, Part 372.

**SARA 311/312 Hazard Categories**

<b>Acute Health Hazard</b>	No
<b>Chronic Health Hazard</b>	Yes
<b>Fire Hazard</b>	No
<b>Sudden Release of Pressure Hazard</b>	No
<b>Reactive Hazard</b>	No

**Clean Water Act**

This product does not contain any substances regulated as pollutants pursuant to the Clean Water Act (40 CFR 122.21 and 40 CFR 122.42).

**CERCLA**

This material, as supplied, does not contain any substances regulated as hazardous substances under the Comprehensive Environmental Response Compensation and Liability Act (CERCLA) (40 CFR 302) or the Superfund Amendments and Reauthorization Act (SARA) (40 CFR 355). There may be specific reporting requirements at the local, regional, or state level pertaining to releases of this material.

**U.S. State Regulations****California Proposition 65**

This product does not contain any Proposition 65 chemicals.

**U.S. State Right-to-Know Regulations**

Chemical Name	New Jersey	Massachusetts	Pennsylvania	Illinois	Rhode Island
Trade Secret	X				
Linseed oil			X		X
Wood dust, all soft and hard woods					X

**International Regulations**

Chemical Name	Carcinogen Status	Exposure Limits
Zirconium ethyl hexoate		Mexico: TWA= 5 mg/m <sup>3</sup> Mexico: STEL= 10 mg/m <sup>3</sup>

**Canada**

This product has been classified in accordance with the hazard criteria of the Controlled Products Regulations (CPR) and the MSDS contains all the information required by the CPR.

**WHMIS Hazard Class**

Non-controlled

<b>16. OTHER INFORMATION</b>
------------------------------

<b>Prepared By</b>	Product Stewardship 23 British American Blvd. Latham, NY 12110 1-800-572-6501
<b>Issuing Date</b>	06-Dec-2010
<b>Revision Date</b>	
<b>Revision Note</b>	Initial Release.

**General Disclaimer**

The information provided on this MSDS is correct to the best of our knowledge, information and belief at the date of its publication. The information given is designed only as a guide for safe handling, use, processing, storage, transportation, disposal and release and is not to be considered as a warranty or quality specification. The information relates only to the specific material designated and may not be valid for such material used in combination with any other material or in any process, unless specified in the text.

**End of Safety Data Sheet**



# AllFlor® Epoxy Fortified Acrylic Floor Enamel 530XX

### Product Description:

This durable, easily applied acrylic enamel is fortified with emulsified epoxy to provide maximum performance in a low gloss, water-based floor and trim finish. It incorporates maximum color retention, breathability, alkali, water and blister resistance and adhesion into it's unique formulation. This is truly the standard for environmentally friendly floor enamels.

### Recommended Use:

Floors, patios, porches, steps, decks, playrooms, basements, wood, concrete and masonry.

### Application:

**WARNING!** If you scrape, sand or remove old paint from any surface, you may release lead dust. LEAD IS TOXIC. EXPOSURE TO LEAD DUST CAN CAUSE SERIOUS ILLNESS, SUCH AS BRAIN DAMAGE, ESPECIALLY IN CHILDREN. PREGNANT WOMEN SHOULD ALSO AVOID EXPOSURE. Wear a NIOSH-approved respirator to control lead exposure. Carefully clean up with a wet mop or HEPA vacuum. Before you start, find out how to protect yourself and your family by contacting the U.S. EPA/Lead Information Hotline at 1-800-424-LEAD (5323) or log on to [www.epa.gov/lead](http://www.epa.gov/lead).

Surfaces must be thoroughly cleaned of all dirt and dust. Dirty surfaces should be washed with a strong detergent solution, rinsed with clean water and allowed to dry overnight. Grease, oils and wax be removed by solvent cleaning to insure proper adhesion of the finish paint. All old, loose, scaly or flaking paint must be removed back to a sound substrate before any repainting is attempted.

New concrete should be allowed to cure a minimum of 30 days before applying any finish. Steel trowelled, hard or glassy smooth concrete should be mechanically abraded to obtain proper adhesion. Curing agents or concrete hardeners can prevent adhesion of any coating unless the surface is mechanically abraded. Under normal conditions acid etching is not recommended but new dusty or chalky concrete should have a coat of Stonite Masonry Conditioner applied before AllFlor is used as a finish. AllFlor is self-priming over unfinished wood and does not require a wood primer.

Material is supplied ready to use but can be thinned up to one pint per gallon with water for first coat on new surfaces or for spot -priming bare areas on old finishes. Finish coat should be applied full body.

### Architectural Specifications:

- Wood, Floors:  
2 coats California AllFlor 530XX
- Concrete, Patios, Breezeways, Steps:  
1 coat Stonite® Masonry Conditioner 7010 as necessary  
1 or 2 coats California AllFlor 530XX (thin first coat 10-20% with water)
- Dados, Walls:  
2 coats California AllFlor 530XX
- Repaint:  
1 coat California AllFlor 530XX

Note: AllFlor can be patched and traffic areas relocated with less difficulty than any other floor finish.

### Precautions:

Do not add solvents, oils or colors in oil, or mix with other paint types. Do not apply when air or surface temperature is below 50° F or when drying conditions are poor. Keep from freezing. Use adequate ventilation. Do not use on garage floors. Hot tires or the weight of a vehicle can cause loss of adhesion. Do not apply over water, glass or other silicate concrete hardeners. Not recommended on areas utilizing heavy duty lift trucks. Tuf-Quik® Urethane Enamel is a better finish for these areas.

### Safety Information:

Keep out of reach of children. Do not take internally. Close container after each use.

### Product Specifications:

**Type:** Acrylic Latex/Epoxy  
**Exposure:** Interior or Exterior  
**Specular Gloss:** 30@ 60° ± 5  
**Volume Solids:** 35.3 % ±2  
**Solids by Weight:** 48.3 % ±2  
**Vehicle:** 76.2 % ±2  
**Pigment:** 23.8 % ±2  
**Dry Film Thickness:** 1.3 mils  
**Viscosity @ 77 °F:** 85 KU ±5  
**Maximum VOC:** 250 g/liter  
**Flash Pt °F:** Non-combustible  
**Thinner:** Water  
**Clean Up:** Soap & Water

### Available Colors and Bases:

White	9 Stock
Pastel	Medium
Deep	

### Available Package Sizes:

Quart	Gallon
-------	--------

(Weight Per Gallon: 10.5 lbs. ± .5 lb)

### Drying Times:

<b>To Touch:</b>	2 hrs.
<b>To Handle:</b>	16 hrs.
<b>To Recoat:</b>	4 hrs.

(@ 70-77 °F, 50% R.H.)

### Surface Spread Rate:

<b>Smooth:</b>	400-450 s.f./gal.
<b>Porous:</b>	350-400 s.f./gal.

(Spray Application is 50% of above)

### Tools and Equipment:

- Brush -**  
Synthetic, Nylon or Polyester
- Roller -**  
3/8" Nap Synthetic Fiber
- Airless Spray -**  
.017 to .019 Tip

# MATERIAL SAFETY DATA SHEET

Per OSHA-recommended ANSI Z400.1-2004 standard format &  
in accordance with European standard format

**1. Product and Company Identification:** **Date of preparation:** October, 2010

Product Name: California® Paints (Brand) Allflor® 100% Acrylic Epoxy Fortified Porch, Floor & Patio  
Low Luster Enamel No. 530XX Series – Tint Bases & Various Colors

Producer: California Products Corporation

150 Dascomb Rd., Andover, MA 01810 (U.S.A.)

All Inquiries to: Tel: (978) 623-9980 Fax: (978) 623-9960

Emergency Information: 24 Hour Contact: CHEM-TEL: (800) 255-3924 (Contract Number: MIS0001450)

**2. Hazards Identification:**

**EMERGENCY OVERVIEW: Product Description:** This product is a pigmented liquid. **Health Hazards:**

The primary hazards presented by this product are the potential for mild irritation of contaminated tissue

and the potential for accidental ingestion. **Flammability Hazards:** This product is not flammable. If this product is involved in a

fire, the decomposition products generated will include irritating vapors and gases and some carbon monoxide. **Reactivity**

**Hazards:** This product is not reactive. **Environmental Hazards:** Although release of this product to the environment is not

expected to cause significant adverse effect, all releases should be avoided. **Emergency Considerations:** Emergency

responders should wear appropriate protection for situation to which they respond.

**3. Composition/Information on Ingredients:**

Non-hazardous:

Pigmented latex emulsion coating comprised of water, pigments, fillers, additives, latex emulsion resin

Hazardous:

Titanium dioxide (CAS #13463-67-7) < 25.0% ACGIH TWA 10 mg/m<sup>3</sup>

\*Ethylene glycol (CAS #107-21-1) < 5.0% OSHA PEL 50 ppm

Note: This product contains more than 0.1% crystalline silica (CAS #14808-60-7) (See note under paragraph #11, "Toxicological Information")

**4. First Aid Measures:**

Eye & Skin contact: Immediately flush eyes with plenty of water for at least 15 minutes and consult physician. Wash skin thoroughly with soap and water. If drenched, remove and wash clothing before reuse. Ingestion: If victim is conscious give 2 glasses of water. Call a physician.

**5. Fire-fighting methods:** Product is non-combustible

**FLASH POINT:** Not flammable

**AUTOIGNITION TEMPERATURE:** Not established

**FLAMMABLE LIMITS (in air by volume, %):**

Lower (LEL): Not applicable

Upper (UEL): Not applicable

**FIRE EXTINGUISHING MATERIALS:** Use extinguishing media appropriate for surrounding fire

Water Spray: OK Carbon Dioxide: OK

Foam: OK Dry Chemical: OK

Halon: OK Other: Any "ABC" Class

**6. Accidental release measures:**

Personal precautions: Do not get in eyes. Do not take internally. Avoid skin contact. Prevent prolonged or repeated breathing of vapor or spray mists. Keep unnecessary people away. Floor may be slippery, use care to avoid falling. Dike and contain material with inert material (e.g. earth, sand). Transfer liquid and contaminated diking material to separate containers for disposal. Environmental precautions: Keep spills and cleaning run-offs out of municipal sewers and open bodies of water. Comply with local, national and state regulations.

**7. Handling and Storage:**

Maximum storage temperature 60°C, minimum 2°C. Keep closure tight and containers upright to prevent leakage. Precautionary labeling: KEEP FROM FREEZING". Product is non-combustible.

**8. Exposure Controls and Personal Protection:**

General protection and hygienic measures: Avoid contact with skin. Do not get in eyes. Do not take internally. Avoid breathing vapors or spray mists. Use in well-ventilated areas. Hand/skin protection: Wear neoprene or rubber gloves to prevent skin contact. Wash hands before eating, smoking or using the wash room. Food or beverages should not be consumed anywhere this product is handled or stored. Respiratory protection: None required if good ventilation is maintained. Wear respirator suitable for concentrations and of contaminants encountered. Use approved chemical/mechanical filters designed to remove particulates in open and restricted ventilation areas. Use approved airline type respirators or hoods in confined areas. Eye/face protection: Use approved safety eyewear including side shields, chemical goggles and face shields.

**9. Physical and Chemical Properties:**

Forms: Viscous liquid, slight ammoniacal odor  
Density: Varies with color  
Solubility in water: Complete colloidal dispersion

**10. Stability and Reactivity:**

Stability: Hazardous polymerization will not occur. Stable. Hazardous reactions: Avoid contact with strong oxidizing agents (e.g. nitric acid, permanganates), etc.

**11. Toxicological Information:**

This product contains more than 0.1% crystalline silica (CAS #14808-60-7) which has been classified by IARC as a Class I carcinogen. Normal application procedures pose no hazard since the silica is wet and encapsulated, but grinding or sanding dried films may yield respirable silica dusts. Control exposures to less than 0.1 mg per cubic meter of air using approved dust filter respirators. Skin contact: Prolonged or repeated contact with product may cause slight skin irritation. Impervious gloves should be worn if prolonged skin contact is likely.

**12. Ecological Information:**

Well-diluted product would have no environmental consequences. Less than 5% ethylene glycol present in this product yields the following environmental fate considerations: Ethylene glycol is 100% volatile. Once volatilized it will react in the atmosphere with hydroxyl radicals with a half-life on about 1 day. For accidental spills, note that ethylene glycol in typical river water at 20°C was found to completely degrade in 3 days. At temperatures of 8°C, degradation occurred in 7 days. Toxicity to fish: LD50 *Carrasius auratus* (goldfish) greater than 5,000 g/L/24 hour. Modified ASTM D 1345. Algae: (*Chlorella pyrenoidosa*) 180,000 mg/L toxic.



**13. Disposal considerations:**

The coating and any contaminated diking material should be thoroughly air dried and collected into drums. The drums should then be sealed and properly labeled with waste designation and land filled or incinerated according to local and national regulations.

**14. Transportation Information:**

U.S. Department of Transportation Hazard Class: "Not Regulated"

Marking: Class 55 Non-hazardous water-based paint

Marking: "Keep from Freezing"

**15. Regulatory Information:**

\*This chemical is subject to the reporting requirements of Section 313 of the Emergency Planning and Community-Right-To-Know Act of 1986 and of 40 CFR 372.

CALIFORNIA SAFE DRINKING WATER AND TOXIC ENFORCEMENT ACT (PROPOSITION 65): Components of this product are on the California Proposition 65 lists.

Information on the maximum volatile organic compound (VOC) content of individual products appears on product labels.

**16. Other Information:**

Note: Per 29CFR 1910.1200 (g) (2) (1) (C) (2), only hazardous substances present in excess of 1.0% by weight (or 0.1% for carcinogens) must be listed on an MSDS.

To comply with New Jersey DOH Right-To-Know labeling law (NJAC 8:59 – 5.1 & 5.2)

CAS. No.:

7732-18-5

107-21-1

13463-67-7

14808-60-7

Not Available +

Not Available +

(+) Contents Partially Unknown

CHEMICAL INGREDIENTS

Water

Ethylene Glycol

Titanium dioxide (Not in neutral bases)

Crystalline Silica

Non-hazardous inorganic filler

Latex Resin Solids

HMIS HAZARD RATING			
Health 1	Flammability 0	Physical Hazard 0	Personal Protection A
HAZARD INDEX			
0=Minimal, 1=Slight, 2=Moderate, 3=Serious, 4=Severe			
PERSONAL PROTECTION CODE:			
A=Safety glasses			

Warning! If you scrape, sand or remove old paint, you may release lead dust. LEAD IS TOXIC. EXPOSURE TO LEAD DUST CAN CAUSE SERIOUS ILLNESS, SUCH AS BRAIN DAMAGE, ESPECIALLY IN CHILDREN. PREGNANT WOMEN SHOULD ALSO AVOID EXPOSURE. Wear a NIOSH-approved respirator to control lead exposure. Clean up carefully with a HEPA vacuum and wet mop. Before you start, find out how to protect yourself and your family by contacting the National Lead Information Hotline at 1-800-424-LEAD (5323) or log on to: [www.epa.gov/lead](http://www.epa.gov/lead)

# Head Blocks, Underhung – 59 Series

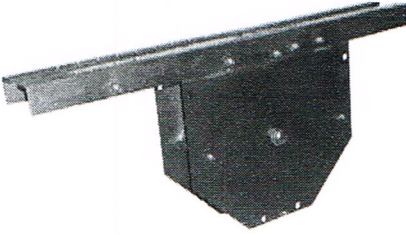

**Underhung Head Block**  
**100-61259C25**

- Underhung style, normally supported by two structural I-beams.
- ASTM Class 30 grey iron or nylon sheave.
- Equal pitch diameter on rope and cable grooves for smooth operation.
- Tapered roller bearings.
- Base angle legs turned in to allow close mounting centers.
- 10 gauge (3.41 mm) side plates fully enclose sheave; 16" (406 mm) blocks have 7 gauge (4.55 mm) side plates.
- Side plates are bolted and welded to the base angles for extra strength.
- Six spacers between the side plates, three prevent cables from escaping the sheave grooves.
- Base angles punched with a hole pattern for easy installations.
- Mounting clips available, please provide steel dimensions.
- **Underhung blocks may need to be welded to head beams after final alignment.** Clip angles are recommended for double beam mounting. Mounting with clips or to single beams will require welding. Consult the factory for specific information.

## Ordering Information

Sheave Dia.	Rope Dia.	Lines	Bearings	Cast Iron Prod. Code	RWL	Wt.	Nylon Prod. Code	RWL	Wt.
8" 203 mm	3/4" 19 mm	6 @ 1/4" 6.35 mm	1" 25.4 mm	100-60859C25	1300 lbs. 590 kg	46 lbs. 20.9 kg	-	-	-
8" 203 mm	3/4" 19 mm	8 @ 1/4" 6.35 mm	1" 25.4 mm	100-80859C25	1300 lbs. 590 kg	52 lbs. 23.6 kg	-	-	-
12" 305 mm	3/4" 19 mm	6 @ 1/4" 6.35 mm	1" 25.4 mm	100-61259C25	3000 lbs. 1361 kg	72 lbs. 32.6 kg	100-61259N25	3000 lbs. 1361 kg	40 lbs. 18.1 kg
12" 305 mm	3/4" 19 mm	8 @ 1/4" 6.35 mm	1" 25.4 mm	100-81259C25	3000 lbs. 1361 kg	79 lbs. 35.8 kg	100-81259N25	3000 lbs. 1361 kg	41 lbs. 18.6 kg
12" 305 mm	3/4" 19 mm	10 @ 1/4" 6.35 mm	1" 25.4 mm	100-101259C25	3000 lbs. 1361 kg	86 lbs. 39 kg	-	-	-
16" 406 mm	1" 25.4 mm	6 @ 3/8" 9.5 mm	1 1/2" 38 mm	100-61659C381	3600 lbs. 1633 kg	139 lbs. 63 kg	-	-	-
16" 406 mm	1" 25.4 mm	8 @ 3/8" 9.5 mm	1 1/2" 38 mm	100-81659C381	3600 lbs. 1633 kg	147 lbs. 66.7 kg	-	-	-

**Double Purchase:** Change "S" to "D" in the part number for double purchase head blocks. Consult Factory for RWL on double purchase blocks.

**Wire Guide Blocks:** Change the "R" suffix to "W" in the part number for blocks with tieoffs for arbor wire guides.

**Tieoffs:** Tieoffs for wire guided clews are also available.

**RWL:** RWL is maximum load that can be applied to a block which is in "like new" condition and has been properly installed, maintained, and operated.

**NOTES:**

1. USE STANDARD STOP SLEEVES OR SWAGED BALL ENDS TO ANCHOR WIRE ROPE.
2. KEEP FOUR (4) WRAPS OF WIRE ROPE WOUND ON DRUM AT ALL TIMES TO SERVE AS ANCHOR WRAPS.
3. INSTALL SUPPLIED BREATHER PLUG AFTER INSTALLATION. SEE OWNERS MANUAL FOR DETAILS.
4. CONTACT FACTORY FOR NON-STANDARD REQUIREMENTS.

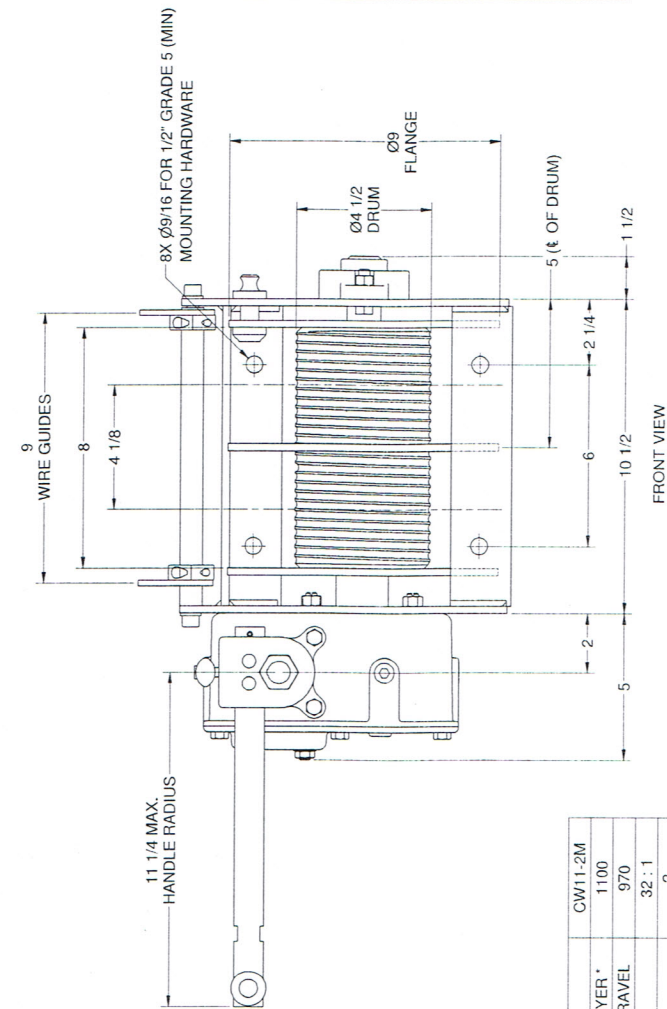

WORKING LOAD LIMIT - 1ST LAYER *	CW11-2M
WORKING LOAD LIMIT - MAX TRAVEL	1100
GEAR RATIO	970
NUMBER OF HAUL LINES	32 : 1
WIRE ROPE (GROOVE) SIZE	2
MAXIMUM TRAVEL **	Ø 1/4"
D : d RATIO	40 FT
TYPICAL HANDLE EFFORT	18.6
FAIL SAFE BRAKE	26 LBS
DESIGN FACTOR	STANDARD
WEIGHT	8 : 1
	73 LBS

\* DRILL-DRIVE OPERATION BASED ON DRILL RATED FOR 10 AMPS AT 350 RPM.

\*\* GREATER TRAVEL POSSIBLE AT REDUCED LOAD RATINGS, CONTACT FACTORY.

SIDE VIEW

FRONT VIEW

NOT FOR CONSTRUCTION

THIS DRAWING IS THE PROPERTY OF THE ISE GROUP AND IS NOT TO BE REPRODUCED OR TRANSMITTED IN ANY FORM OR BY ANY MEANS, ELECTRONIC OR MECHANICAL, WITHOUT WRITTEN APPROVAL BY THE ISE GROUP.

**ISE**  
TERRAZZO EQUIPMENT  
1000 W. WASHINGTON  
WYOMING, WY 83097  
TEL: 307-334-2200  
FAX: 307-334-2204  
WWW.ISEGROUP.COM

MANUAL CLEW WINCH  
CW11 SERIES  
D3453

JCA 9142309 N/A NIS HANSON 2 SHEET OF 1

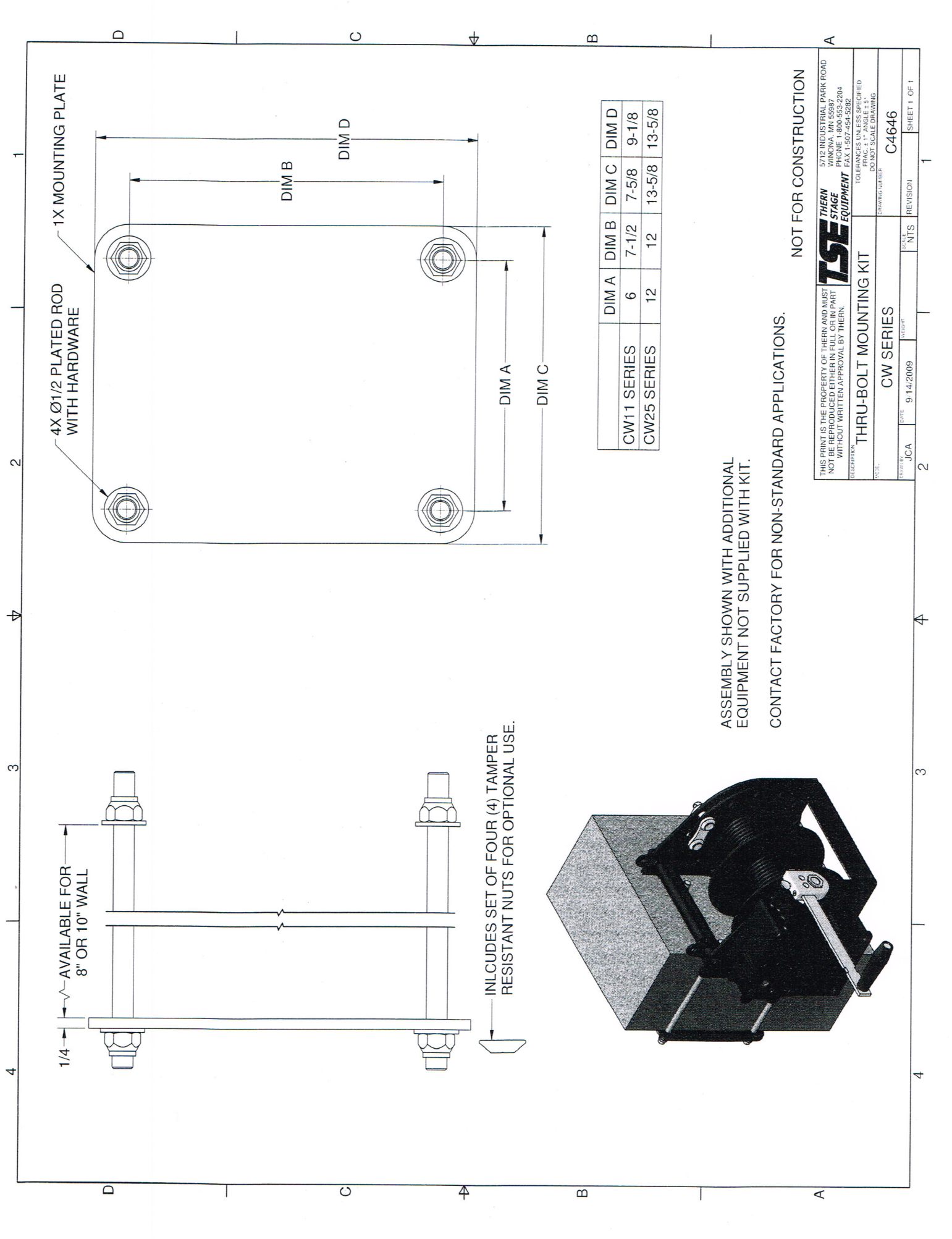

	DIM A	DIM B	DIM C	DIM D
CW11 SERIES	6	7-1/2	7-5/8	9-1/8
CW25 SERIES	12	12	13-5/8	13-5/8

ASSEMBLY SHOWN WITH ADDITIONAL EQUIPMENT NOT SUPPLIED WITH KIT.

CONTACT FACTORY FOR NON-STANDARD APPLICATIONS.

NOT FOR CONSTRUCTION

THIS PRINT IS THE PROPERTY OF THERN AND MUST NOT BE REPRODUCED EITHER IN FULL OR IN PART WITHOUT WRITTEN APPROVAL BY THERN.

**THERN**  
**TSE**  
**STAGE**  
**EQUIPMENT**

5712 INDUSTRIAL PARK ROAD  
WINONA, MN 55987  
TEL: 507-564-5200  
FAX: 507-564-5284

DESCRIPTION: THRU-BOLT MOUNTING KIT  
TOLERANCES UNLESS SPECIFIED:  
FRAC: 1/16" ANGLE: ± 5°  
DIMENSIONS UNLESS OTHERWISE SPECIFIED

DATE: 9-14-2009  
SCALE: NTS  
REVISION: 1

CW SERIES  
C4646

SHEET 1 OF 1

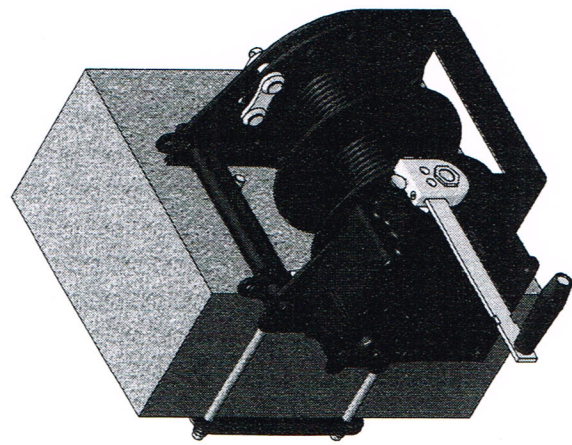

INCLUDES SET OF FOUR (4) TAMPER RESISTANT NUTS FOR OPTIONAL USE.

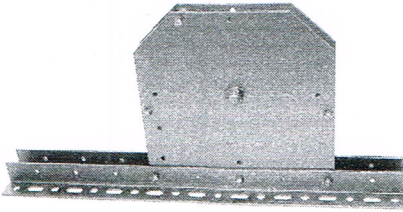

**Universal Loft Block**  
**200-10856N25**

*NEW – 56 Series  
750 lb. (340 kg) capacity!*

- May be mounted upright or underhung.
- May be supported by I-beams, grid wells, or Unistrut™.
- Nylon or ASTM Class 30 grey iron sheaves.
- 8" (203 mm) blocks have 24" (610 mm) base angles with a continuous pattern of holes and slots for universal mounting for a grip range up to 20" (508 mm). Multi-line block base angles have a series of mounting holes.
- 8-Line blocks have the base angles turned in, requiring different upright and underhung models.
- A clip package is available for single line blocks with a combination of J-bolts and clips for both underhung and upright mounting options.
- Sealed precision ball bearings (Single line, 8" [203 mm] nominal sheave only) or tapered roller bearings.
- Side plates fully enclose sheave.
- Five spacers between the side plates, three of which prevent cables from escaping the sheave grooves.
- Pivot adapters (070-PIVOT) are available for single line 8" (203 mm) blocks used in applications where the mounting surface is sloped.
- Underhung loft blocks may need to be welded to loft beams after final alignment – consult the factory for specific information.

**Ordering Information**

Sheave Diameter	Lines	Bearings	Cast Iron Prod. Code	RWL	Wt.	Nylon Prod. Code	RWL	Wt.
<b>Cable Blocks (1/4" (6.35 mm) cable)</b>								
8 1/2" 216 mm	1	17 mm BB	200-10855C25	500 lbs. 227 kg	20 lbs. 9 kg	200-10856N25	750 lbs. 340 kg	15 lbs. 6.8 kg
8 1/2" 216 mm	2	17 mm BB	200-20855C25	700 lbs. 317 kg	20 lbs. 9 kg	200-20855N25	750 lbs. 340 kg	16 lbs. 7.25 kg
8 1/2" 216 mm	1	17 mm TRB	200-10856C25T	500 lbs. 227 kg	20 lbs. 9 kg	200-10856N25T	750 lbs. 340 kg	15 lbs. 6.8 kg
8 1/2" 216 mm	2	17 mm TRB	200-20855C25T	700 lbs. 317 kg	20 lbs. 9 kg	200-20855N25T	750 lbs. 340 kg	16 lbs. 7.25 kg
8 1/2" 216 mm	4	1" TRB 25.4 mm	200-40855C25	1300 lbs. 590 kg	40 lbs. 18 kg	200-40855N25	1300 lbs. 590 kg	31 lbs. 14 kg
8 1/2" Upright 216 mm	8	1" TRB 25.4 mm	200-80855C25	1300 lbs. 590 kg	52 lbs. 23.5 kg	200-80855N25	1300 lbs. 590 kg	32 lbs. 14.5 kg
8 1/2" Underhung 216 mm	8	1" TRB 25.4 mm	200-80859C25	1300 lbs. 590 kg	52 lbs. 23.5 kg	200-80859N25	1300 lbs. 590 kg	32 lbs. 14.5 kg
8 1/2" Upright 216 mm	10	1" TRB 25.4 mm	200-100855C25	1300 lbs. 590 kg	55 lbs. 25 kg	-	-	-
8 1/2" Underhung 216 mm	10	1" TRB 25.4 mm	200-100859C25	1300 lbs. 590 kg	55 lbs. 25 kg	-	-	-
12"* 305 mm	1	1" TRB 25.4 mm	200-11255C25	700 lbs. 317 kg	50 lbs. 22.7 kg	-	-	-
12" 305 mm	2	1" TRB 25.4 mm	200-21255	1400 lbs. 634 kg	50 lbs. 22.7 kg	-	-	-
12" Upright 305 mm	8	1" TRB 25.4 mm	200-81255C25	3000 lbs. 1361 kg	74 lbs. 33.5 kg	-	-	-
12" Underhung 305 mm	8	1" TRB 25.4 mm	200-81259C25	2500 lbs. 1134 kg	74 lbs. 33.5 kg	-	-	-
16"* 406 mm	1	1" TRB 25.4 mm	200-11655S38	1400 lbs. 634 kg	110 lbs. 50 kg	-	-	-
<b>Cable Blocks (3/16" (4.76 mm) cable)</b>								
8 1/2" 216 mm	1	17 mm BB	-	-	-	200-10855N19	500 lbs. 317 kg	15 lbs. 6.8 kg
8 1/2" 216 mm	1	17 mm TRB	-	-	-	200-10855N19T	500 lbs. 317 kg	15 lbs. 6.8 kg
8 1/2" 216 mm	8	1" TRB 25.4 mm	-	-	-	200-80855N19	1300 lbs. 590 kg	28 lbs. 12.7 kg
8 1/2" 216 mm	8	1" TRB 25.4 mm	-	-	-	200-80859N19	1300 lbs. 590 kg	28 lbs. 12.7 kg
<b>Rope Blocks (3/4" (19 mm) rope)</b>								
8" 203 mm	1	17 mm BB	200-10855C75	300 lbs. 136 kg	20 lbs. 9 kg	200-10855N75	300 lbs. 136 kg	15 lbs. 6.8 kg
8" 203 mm	1	17 mm TRB	200-10855C75T	300 lbs. 136 kg	20 lbs. 9 kg	200-10855N75T	300 lbs. 136 kg	15 lbs. 6.8 kg

\*AVAILABLE FOR 1/4" (6.35 mm) OR 3/8" (9.5 mm) CABLE, SPECIFY. (RWL FOR 1/4" (6.35 mm) GROOVE 700 LBS. (317 kg), FOR 3/8" (9.5 mm) GROOVE 1050 LBS. (476 kg))

+STEEL SHEAVE, AVAILABLE FOR 3/8" (9.5 mm) OR 1/2" (12.7 mm) CABLE, SPECIFY.

**RWL:** RWL is maximum load that can be applied to a block which is in "like new" condition and has been properly installed, maintained, and operated.

Dimensions

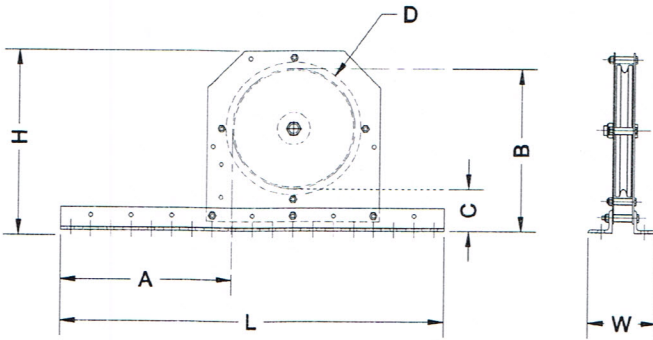

Nominal Sheave Diam.	Lines	Dim. L	Dim. H	Dim. W	Dim. A	Dim. B	Dim. C*	Dim. D (Sheave Diam.)	Sideplate
8" 203 mm	1	24 3/8" 619 mm	11 5/8" 295.3 mm	4 3/8" 111 mm	10 7/8" 276.2 mm	10 1/2" 266.7 mm	2 3/4" 70 mm	8 9/16" 217 mm	12 GA 2.65 mm
8" 203 mm	2	24 3/8" 619 mm	11 5/8" 295.3 mm	4 3/8" 111 mm	10 7/8" 276.2 mm	10 1/2" 266.7 mm	2 3/4" 70 mm	8 9/16" 217 mm	12 GA 2.65 mm
8" 203 mm	4	21" 533 mm	11 7/16" 290.5 mm	5 1/2" 139.7 mm	8 13/16" 223.8 mm	10 1/8" 257 mm	2 1/4" 57 mm	8 1/2" 216 mm	10 GA 3.4 mm
8" 203 mm	8	32"+ 813 mm	11 7/16" 290.5 mm	5 1/2" 139.7 mm	8 13/16" 223.8 mm	10 1/8" 257 mm	2 1/4" 57 mm	8 1/2" 216 mm	10 GA 3.4 mm
8" 203 mm	10	32"+ 813 mm	11 7/16" 290.5 mm	6 3/16" 157 mm	8 13/16" 223.8 mm	10 1/8" 257 mm	2 1/4" 57 mm	8 1/2" 216 mm	10 GA 3.4 mm
12" 305 mm	1	28" 711 mm	15" 381 mm	4 3/4" 120.6 mm	12 3/8" 314.3 mm	13 3/4" 349.2 mm	2 3/8" 60.3 mm	12" 305 mm	10 GA 3.4 mm
12" 305 mm	2	28" 711 mm	15" 381 mm	4 3/4" 120.6 mm	12 3/8" 314.3 mm	13 3/4" 349.2 mm	2 3/8" 60.3 mm	12" 305 mm	10 GA 3.4 mm
12" 305 mm	8	34" 864 mm	15" 381 mm	5 3/8" 136.5 mm	13 5/16" 338 mm	13 11/16" 347.7 mm	2 15/16" 74.6 mm	12" 305 mm	10 GA 3.4 mm
16" 406 mm	1	26" 660 mm	19" 483 mm	5 1/4" 133.3 mm	22 3/4" 578 mm	17 3/4" 450.8 mm	2 1/8" 54 mm	16" 406 mm	7 GA 4.55 mm

\*DIMENSION TO CABLE C/L WHEN BLOCK IS USED IN UNDERHUNG APPLICATION.

+32" (813 mm) FOR UPRIGHT

21" (533 mm) FOR UNDERHUNG

# Battens



**Batten  
015-67R**

- Battens are made from seamless pipe and are supplied with a matte black finish.
- Battens up to 21' (6.4 m) long are supplied as a single piece; longer battens are provided with 18" (457 mm) long internal splice sleeves.
- Standard 1 1/2" (38 mm) battens are provided with safety yellow vinyl end caps, making the batten ends easier to see.
- Two pipe ladder trusses are constructed from two 1 1/2" (38 mm) sch 40 pipes with flat bar spacers on 4' (1.219 m) centers. Other special constructions are available, consult factory.

## Ordering Information

Product Code	Description	I.D.	O.D.	Wt
015-67R	1 1/2" (38 mm) Sch 40 batten	1.610" 40.9 mm	1.900" 48.26 mm	3 lbs./ft. 4.45 kg/m
015-67H	1 1/2" (38 mm) Sch 80 batten	1.500" 38 mm	1.900" 48.26 mm	4 lbs./ft. 5.9 kg/m
015-68R	2" (51 mm) Sch 40 batten	2.067" 52.5 mm	2.375" 60.325 mm	4 lbs./ft. 5.9 kg/m
015-69R	2 1/2" (64 mm) Sch 40 batten	2.469" 62.7 mm	2.875" 73.025 mm	6 lbs./ft. 8.9 kg/m
015-67T	Two pipe truss batten	1.610" 40.9 mm	1.900" 48.26 mm	7 lbs./ft. 10.4 kg/m
015-67S	1 1/2" (38 mm) Batten sleeve, no holes, 18" long (457 mm)	-	-	3 lbs. 1.3 kg
015-68S	2" (51 mm) Batten sleeve, no holes, 18" long (457 mm)	-	-	4 lbs. 1.8 kg
015-69S	2 1/2" (64 mm) Batten sleeve, no holes, 18" long (457 mm)	-	-	9 lbs. 4 kg
099-BATCAP	Yellow batten end caps, 4" (102 mm) long	-	-	0.1 lb. 0.04 kg

## Dimensions

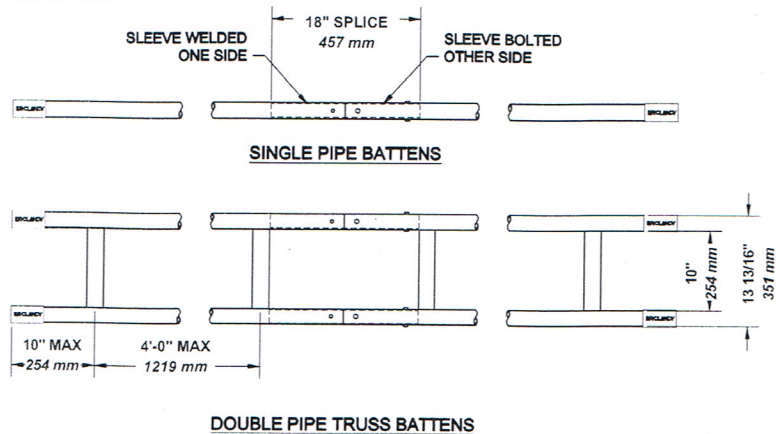



## Fabric Specifications

<b>Fabric</b>	<b>Ovation</b>	<b>Prestige</b>
<b>Width:</b>	56 inches	54 inches
<b>Fabric Content:</b>	100% Polyester	100% Polyester
<b>Weight (Lin):</b>	15 Ounces	24 - 25 Ounces
<b>Fire Spec:</b>	Inherently Flame Resistant	Inherently Flame Resistant
<b>Fire Rating:</b>	NFPA 701 Small Scale	NFPA 701 Small Scale
	NFPA 701 1989 large Scale	NFPA 701 1989 large Scale
	ASTME84	ASTME85
<b>Care Info:</b>	Will not loose flame resistance with washing. Cold Water Wash, Delicate, No Bleach, Dry Flat, Wash Dark Colors	Will not loose flame resistance with washing. Cold Water Wash, Delicate, No Bleach, Dry Flat, Wash Dark Colors
<b>Piece Size:</b>	60 Yards Approx.	60 Yards Approx.

**From:** "MA Prevailing Wage" <prevailingwages@state.ma.us>  
**To:** dlantzillotti@town.arlington.ma.us  
**Date:** 03/30/2015 04:47 PM  
**Subject:** Prevailing wage schedule for Wage Request number :20150330-076

---

To view and print Weekly Payroll & Statement of Compliance Forms, click on [www.mass.gov/dols/pw](http://www.mass.gov/dols/pw).

PLEASE NOTE: The attached Prevailing Wage Schedule is valid for 90 days. An Awarding Authority should re-request an up to date Prevailing Wage Schedule if it has NOT opened bids or selected a contractor within 90 days of the issuance date of the attached prevailing wage schedule.

\*For MULTI-YEAR projects bid on or after 8/8/08, Awarding Authorities must request an Annual Update to this Prevailing Wage Schedule each year for the duration of the project, no later than two weeks before the anniversary date of the execution of the general contract. Annual updates are not required for projects that last LESS THAN ONE YEAR.

\*For CM AT RISK projects (bid pursuant to GL c.149A), Awarding Authorities must request a Prevailing Wage Schedule NOT sooner than 90-days before the earlier of: (a) the execution date of the GMP Amendment, or (b) the bid for the first construction scope of work.

\*For MULTI-YEAR CM AT RISK projects, Awarding Authorities must request an Annual Update to this Prevailing Wage Schedule each year for the duration of the project, no later than two weeks before the anniversary date, which is the earlier of: (a) the execution date of the GMP Amendment, or (b) the execution date of the first amendment to procure construction scopes of work.

Apprentice wages (expressed as dollar figures) and the required benefits are listed on the Prevailing Wage Schedule. For further details, please see opinion letter PW-2010-03-03.16.10 (dated March 18, 2010) at [www.mass.gov/dols/pw](http://www.mass.gov/dols/pw).

Request Prevailing Wage Rates online at: [www.mass.gov/dols/pw](http://www.mass.gov/dols/pw).

THIS IS A SYSTEM-GENERATED EMAIL. PLEASE DO NOT REPLY TO THIS EMAIL.  
TO CONTACT DLS REGARDING PREVAILING WAGE MATTERS, CALL 617-626-6953.

---

APPROVAL/DENIAL COMMENTS

This e-mail message, including any attachments, is for the sole use of the intended recipient(s) and may contain confidential and privileged information. Any unauthorized review, use, disclosure, or distribution is strictly prohibited and may be the subject of legal action. If you are not the intended recipient, please contact the sender by reply

e-mail and destroy all copies of the original message. Thank you.

**Attachments:**

File: 20150330-076.pdf      Size: 166k      Content Type: application/pdf

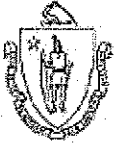

**THE COMMONWEALTH OF MASSACHUSETTS  
EXECUTIVE OFFICE OF LABOR AND WORKFORCE DEVELOPMENT  
DEPARTMENT OF LABOR STANDARDS**

**Prevailing Wage Rates**

As determined by the Director under the provisions of the  
Massachusetts General Laws, Chapter 149, Sections 26 to 27H

CHARLES D. BAKER  
Governor

KARYNE E. POLITO  
Lt. Governor

RONALD L. WALKER, II  
Secretary

JEAN ZEILER  
Acting Director

**Awarding Authority:** Town of Arlington  
**Contract Number:** 15-13 **City/Town:** ARLINGTON  
**Description of Work:** Ottoson School - Furnish all labor, materials, equipment and supervision necessary for the replacement of stage decking and curtain equipment as per specifications.  
**Job Location:** 63 Acton St.

Information about Prevailing Wage Schedules for Awarding Authorities and Contractors

- This wage schedule applies only to the specific project referenced at the top of this page and uniquely identified by the "Wage Request Number" on all pages of this schedule.
- An Awarding Authority must request an updated wage schedule from the Department of Labor Standards ("DLS") if it has not opened bids or selected a contractor within 90 days of the date of issuance of the wage schedule. For CM AT RISK projects (bid pursuant to G.L. c.149A), the earlier of: (a) the execution date of the GMP Amendment, or (b) the bid for the first construction scope of work must be within 90-days of the wage schedule issuance date.
- The wage schedule shall be incorporated in any advertisement or call for bids for the project as required by M.G.L. c. 149, § 27. The wage schedule shall be made a part of the contract awarded for the project. The wage schedule must be posted in a conspicuous place at the work site for the life of the project in accordance with M.G.L. c. 149 § 27. The wages listed on the wage schedule must be paid to employees performing construction work on the project whether they are employed by the prime contractor, a filed sub-bidder, or any sub-contractor.
- All apprentices working on the project are required to be registered with the Massachusetts Division of Apprentice Standards (DAS). Apprentice must keep his/her apprentice identification card on his/her person during all work hours on the project. An apprentice registered with DAS may be paid the lower apprentice wage rate at the applicable step as provided on the prevailing wage schedule. **If an apprentice rate is not listed on the prevailing wage schedule for the trade in which an apprentice is registered with the DAS, the apprentice must be paid the journeyworker's rate for the trade.**
- The wage rates will remain in effect for the duration of the project, except in the case of multi-year public construction projects. For construction projects lasting longer than one year, awarding authorities must request an updated wage schedule. Awarding authorities are required to request these updates no later than two weeks before the anniversary of the date the contract was executed by the awarding authority and the general contractor. For multi-year CM AT RISK projects, awarding authority must request an annual update no later than two weeks before the anniversary date, determined as the earlier of: (a) the execution date of the GMP Amendment, or (b) the execution date of the first amendment to permit procurement of construction services. Contractors are required to obtain the wage schedules from awarding authorities, and to pay no less than these rates to covered workers. The annual update requirement is not applicable to 27F "rental of equipment" contracts.
- Every contractor or subcontractor which performs construction work on the project is required to submit weekly payroll reports and a Statement of Compliance directly to the awarding authority by mail or email and keep them on file for three years. Each weekly payroll report must contain: the employee's name, address, occupational classification, hours worked, and wages paid. Do not submit weekly payroll reports to DLS. A sample of a payroll reporting form may be obtained at <http://www.mass.gov/dols/pw>.
- Contractors with questions about the wage rates or classifications included on the wage schedule have an affirmative obligation to inquire with DLS at (617) 626-6953.
- Employees not receiving the prevailing wage rate set forth on the wage schedule may report the violation to the Fair Labor Division of the office of the Attorney General at (617) 727-3465.
- Failure of a contractor or subcontractor to pay the prevailing wage rates listed on the wage schedule to all employees who perform construction work on the project is a violation of the law and subjects the contractor or subcontractor to civil and criminal penalties.

Classification	Effective Date	Base Wage	Health	Pension	Supplemental Unemployment	Total Rate
<b>Construction</b>						
(2 AXLE) DRIVER - EQUIPMENT <i>TEAMSTERS JOINT COUNCIL NO. 10 ZONE A</i>	12/01/2014	\$32.40	\$9.91	\$9.33	\$0.00	\$51.64
	06/01/2015	\$32.75	\$9.91	\$9.33	\$0.00	\$51.99
	08/01/2015	\$32.75	\$10.41	\$9.33	\$0.00	\$52.49
	12/01/2015	\$32.75	\$10.41	\$10.08	\$0.00	\$53.24
	06/01/2016	\$33.25	\$10.41	\$10.08	\$0.00	\$53.74
	08/01/2016	\$33.25	\$10.91	\$10.08	\$0.00	\$54.24
	12/01/2016	\$33.25	\$10.91	\$10.89	\$0.00	\$55.05
(3 AXLE) DRIVER - EQUIPMENT <i>TEAMSTERS JOINT COUNCIL NO. 10 ZONE A</i>	12/01/2014	\$32.47	\$9.91	\$9.33	\$0.00	\$51.71
	06/01/2015	\$32.82	\$9.91	\$9.33	\$0.00	\$52.06
	08/01/2015	\$32.82	\$10.41	\$9.33	\$0.00	\$52.56
	12/01/2015	\$32.82	\$10.41	\$10.08	\$0.00	\$53.31
	06/01/2016	\$33.32	\$10.41	\$10.08	\$0.00	\$53.81
	08/01/2016	\$33.32	\$10.91	\$10.08	\$0.00	\$54.31
	12/01/2016	\$33.32	\$10.91	\$10.89	\$0.00	\$55.12
(4 & 5 AXLE) DRIVER - EQUIPMENT <i>TEAMSTERS JOINT COUNCIL NO. 10 ZONE A</i>	12/01/2014	\$32.59	\$9.91	\$9.33	\$0.00	\$51.83
	06/01/2015	\$32.94	\$9.91	\$9.33	\$0.00	\$52.18
	08/01/2015	\$32.94	\$10.41	\$9.33	\$0.00	\$52.68
	12/01/2015	\$32.94	\$10.41	\$10.08	\$0.00	\$53.43
	06/01/2016	\$33.44	\$10.41	\$10.08	\$0.00	\$53.93
	08/01/2016	\$33.44	\$10.91	\$10.08	\$0.00	\$54.43
	12/01/2016	\$33.44	\$10.91	\$10.89	\$0.00	\$55.24
ADS/SUBMERSIBLE PILOT <i>PILE DRIVER LOCAL 56 (ZONE 1)</i>	08/01/2014	\$87.36	\$9.80	\$18.17	\$0.00	\$115.33
	08/01/2015	\$90.51	\$9.80	\$18.17	\$0.00	\$118.48
AIR TRACK OPERATOR <i>LABORERS - ZONE 1</i>	12/01/2014	\$35.35	\$7.30	\$12.95	\$0.00	\$55.60
	06/01/2015	\$36.10	\$7.30	\$12.95	\$0.00	\$56.35
	12/01/2015	\$36.85	\$7.30	\$12.95	\$0.00	\$57.10
	06/01/2016	\$37.60	\$7.30	\$12.95	\$0.00	\$57.85
	12/01/2016	\$38.60	\$7.30	\$12.95	\$0.00	\$58.85
For apprentice rates see "Apprentice- LABORER"						
ASBESTOS REMOVER - PIPE / MECH. EQUIPT. <i>HEAT &amp; FROST INSULATORS LOCAL 6 (BOSTON)</i>	12/01/2014	\$32.48	\$10.40	\$5.95	\$0.00	\$48.83
	06/01/2015	\$33.43	\$10.40	\$5.95	\$0.00	\$49.78
	12/01/2015	\$34.38	\$10.40	\$5.95	\$0.00	\$50.73
ASPHALT RAKER <i>LABORERS - ZONE 1</i>	12/01/2014	\$34.85	\$7.30	\$12.95	\$0.00	\$55.10
	06/01/2015	\$35.60	\$7.30	\$12.95	\$0.00	\$55.85
	12/01/2015	\$36.35	\$7.30	\$12.95	\$0.00	\$56.60
	06/01/2016	\$37.10	\$7.30	\$12.95	\$0.00	\$57.35
	12/01/2016	\$38.10	\$7.30	\$12.95	\$0.00	\$58.35
For apprentice rates see "Apprentice- LABORER"						
ASPHALT/CONCRETE/CRUSHER PLANT-ON SITE <i>OPERATING ENGINEERS LOCAL 4</i>	12/01/2014	\$42.39	\$10.00	\$14.30	\$0.00	\$66.69
	06/01/2015	\$43.14	\$10.00	\$14.30	\$0.00	\$67.44
	12/01/2015	\$44.39	\$10.00	\$14.30	\$0.00	\$68.69
	06/01/2016	\$45.14	\$10.00	\$14.30	\$0.00	\$69.44
	12/01/2016	\$46.39	\$10.00	\$14.30	\$0.00	\$70.69
	06/01/2017	\$47.39	\$10.00	\$14.30	\$0.00	\$71.69
	12/01/2017	\$48.39	\$10.00	\$14.30	\$0.00	\$72.69

Classification	Effective Date	Base Wage	Health	Pension	Supplemental Unemployment	Total Rate
For apprentice rates see "Apprentice- OPERATING ENGINEERS"						
BACKHOE/FRONT-END LOADER OPERATING ENGINEERS LOCAL 4	12/01/2014	\$42.39	\$10.00	\$14.30	\$0.00	\$66.69
	06/01/2015	\$43.14	\$10.00	\$14.30	\$0.00	\$67.44
	12/01/2015	\$44.39	\$10.00	\$14.30	\$0.00	\$68.69
	06/01/2016	\$45.14	\$10.00	\$14.30	\$0.00	\$69.44
	12/01/2016	\$46.39	\$10.00	\$14.30	\$0.00	\$70.69
	06/01/2017	\$47.39	\$10.00	\$14.30	\$0.00	\$71.69
	12/01/2017	\$48.39	\$10.00	\$14.30	\$0.00	\$72.69
For apprentice rates see "Apprentice- OPERATING ENGINEERS"						
BARCO-TYPE JUMPING TAMPER LABORERS - ZONE 1	12/01/2014	\$34.85	\$7.30	\$12.95	\$0.00	\$55.10
	06/01/2015	\$35.60	\$7.30	\$12.95	\$0.00	\$55.85
	12/01/2015	\$36.35	\$7.30	\$12.95	\$0.00	\$56.60
	06/01/2016	\$37.10	\$7.30	\$12.95	\$0.00	\$57.35
	12/01/2016	\$38.10	\$7.30	\$12.95	\$0.00	\$58.35
For apprentice rates see "Apprentice- LABORER"						
BLOCK PAVER, RAMMER / CURB SETTER LABORERS - ZONE 1	12/01/2014	\$35.35	\$7.30	\$12.95	\$0.00	\$55.60
	06/01/2015	\$36.10	\$7.30	\$12.95	\$0.00	\$56.35
	12/01/2015	\$36.85	\$7.30	\$12.95	\$0.00	\$57.10
	06/01/2016	\$37.60	\$7.30	\$12.95	\$0.00	\$57.85
	12/01/2016	\$38.60	\$7.30	\$12.95	\$0.00	\$58.85
For apprentice rates see "Apprentice- LABORER"						
BOILER MAKER BOILERMAKERS LOCAL 29	01/01/2010	\$37.70	\$6.97	\$11.18	\$0.00	\$55.85

**Apprentice - BOILERMAKER - Local 29**

**Effective Date - 01/01/2010**

Step	percent	Apprentice Base Wage	Health	Pension	Supplemental Unemployment	Total Rate
1	65	\$24.51	\$6.97	\$11.18	\$0.00	\$42.66
2	65	\$24.51	\$6.97	\$11.18	\$0.00	\$42.66
3	70	\$26.39	\$6.97	\$11.18	\$0.00	\$44.54
4	75	\$28.28	\$6.97	\$11.18	\$0.00	\$46.43
5	80	\$30.16	\$6.97	\$11.18	\$0.00	\$48.31
6	85	\$32.05	\$6.97	\$11.18	\$0.00	\$50.20
7	90	\$33.93	\$6.97	\$11.18	\$0.00	\$52.08
8	95	\$35.82	\$6.97	\$11.18	\$0.00	\$53.97

**Notes:**

**Apprentice to Journeyworker Ratio:1:5**

BRICK/STONE/ARTIFICIAL MASONRY (INCL. MASONRY WATERPROOFING) BRICKLAYERS LOCAL 3 (BOSTON)	02/01/2015	\$48.96	\$10.18	\$18.50	\$0.00	\$77.64
	08/01/2015	\$49.86	\$10.18	\$18.57	\$0.00	\$78.61
	02/01/2016	\$50.43	\$10.18	\$18.57	\$0.00	\$79.18
	08/01/2016	\$51.33	\$10.18	\$18.65	\$0.00	\$80.16
	02/01/2017	\$51.90	\$10.18	\$18.65	\$0.00	\$80.73

**Classification**

**Effective Date    Base Wage    Health    Pension    Supplemental Unemployment    Total Rate**

**Apprentice - BRICK/PLASTER/CEMENT MASON - Local 3 Boston**

**Effective Date - 02/01/2015**

Step	percent	Apprentice Base Wage	Health	Pension	Supplemental Unemployment	Total Rate
1	50	\$24.48	\$10.18	\$18.50	\$0.00	\$53.16
2	60	\$29.38	\$10.18	\$18.50	\$0.00	\$58.06
3	70	\$34.27	\$10.18	\$18.50	\$0.00	\$62.95
4	80	\$39.17	\$10.18	\$18.50	\$0.00	\$67.85
5	90	\$44.06	\$10.18	\$18.50	\$0.00	\$72.74

**Effective Date - 08/01/2015**

Step	percent	Apprentice Base Wage	Health	Pension	Supplemental Unemployment	Total Rate
1	50	\$24.93	\$10.18	\$18.57	\$0.00	\$53.68
2	60	\$29.92	\$10.18	\$18.57	\$0.00	\$58.67
3	70	\$34.90	\$10.18	\$18.57	\$0.00	\$63.65
4	80	\$39.89	\$10.18	\$18.57	\$0.00	\$68.64
5	90	\$44.87	\$10.18	\$18.57	\$0.00	\$73.62

**Notes:**

**Apprentice to Journeyworker Ratio:1:5**

<b>BULLDOZER/GRADER/SCRAPER</b>	12/01/2014	\$41.99	\$10.00	\$14.30	\$0.00	\$66.29
<i>OPERATING ENGINEERS LOCAL 4</i>	06/01/2015	\$42.73	\$10.00	\$14.30	\$0.00	\$67.03
	12/01/2015	\$43.97	\$10.00	\$14.30	\$0.00	\$68.27
	06/01/2016	\$44.72	\$10.00	\$14.30	\$0.00	\$69.02
	12/01/2016	\$45.95	\$10.00	\$14.30	\$0.00	\$70.25
	06/01/2017	\$46.94	\$10.00	\$14.30	\$0.00	\$71.24
	12/01/2017	\$47.93	\$10.00	\$14.30	\$0.00	\$72.23

For apprentice rates see "Apprentice- OPERATING ENGINEERS"

<b>CAISSON &amp; UNDERPINNING BOTTOM MAN</b>	12/01/2014	\$35.70	\$7.30	\$13.15	\$0.00	\$56.15
<i>LABORERS - FOUNDATION AND MARINE</i>	06/01/2015	\$36.45	\$7.30	\$13.15	\$0.00	\$56.90
	12/01/2015	\$37.20	\$7.30	\$13.15	\$0.00	\$57.65
	06/01/2016	\$37.95	\$7.30	\$13.15	\$0.00	\$58.40
	12/01/2016	\$38.95	\$7.30	\$13.15	\$0.00	\$59.40

For apprentice rates see "Apprentice- LABORER"

<b>CAISSON &amp; UNDERPINNING LABORER</b>	12/01/2014	\$34.55	\$7.30	\$13.15	\$0.00	\$55.00
<i>LABORERS - FOUNDATION AND MARINE</i>	06/01/2015	\$35.30	\$7.30	\$13.15	\$0.00	\$55.75
	12/01/2015	\$36.05	\$7.30	\$13.15	\$0.00	\$56.50
	06/01/2016	\$36.80	\$7.30	\$13.15	\$0.00	\$57.25
	12/01/2016	\$37.80	\$7.30	\$13.15	\$0.00	\$58.25

For apprentice rates see "Apprentice- LABORER"

Classification	Effective Date	Base Wage	Health	Pension	Supplemental Unemployment	Total Rate
CAISSON & UNDERPINNING TOP MAN <i>LABORERS - FOUNDATION AND MARINE</i>	12/01/2014	\$34.55	\$7.30	\$13.15	\$0.00	\$55.00
	06/01/2015	\$35.30	\$7.30	\$13.15	\$0.00	\$55.75
	12/01/2015	\$36.05	\$7.30	\$13.15	\$0.00	\$56.50
	06/01/2016	\$36.80	\$7.30	\$13.15	\$0.00	\$57.25
	12/01/2016	\$37.80	\$7.30	\$13.15	\$0.00	\$58.25
For apprentice rates see "Apprentice- LABORER"						
CARBIDE CORE DRILL OPERATOR <i>LABORERS - ZONE 1</i>	12/01/2014	\$34.85	\$7.30	\$12.95	\$0.00	\$55.10
	06/01/2015	\$35.60	\$7.30	\$12.95	\$0.00	\$55.85
	12/01/2015	\$36.35	\$7.30	\$12.95	\$0.00	\$56.60
	06/01/2016	\$37.10	\$7.30	\$12.95	\$0.00	\$57.35
	12/01/2016	\$38.10	\$7.30	\$12.95	\$0.00	\$58.35
For apprentice rates see "Apprentice- LABORER"						
CARPENTER <i>CARPENTERS -ZONE 2 (Eastern Massachusetts)</i>	03/01/2015	\$35.75	\$9.80	\$16.48	\$0.00	\$62.03

**Apprentice - CARPENTER - Zone 2 Eastern MA**

**Effective Date - 03/01/2015**

Step	percent	Apprentice Base Wage	Health	Pension	Supplemental Unemployment	Total Rate
1	50	\$17.88	\$9.80	\$1.63	\$0.00	\$29.31
2	60	\$21.45	\$9.80	\$1.63	\$0.00	\$32.88
3	70	\$25.03	\$9.80	\$11.59	\$0.00	\$46.42
4	75	\$26.81	\$9.80	\$11.59	\$0.00	\$48.20
5	80	\$28.60	\$9.80	\$13.22	\$0.00	\$51.62
6	80	\$28.60	\$9.80	\$13.22	\$0.00	\$51.62
7	90	\$32.18	\$9.80	\$14.85	\$0.00	\$56.83
8	90	\$32.18	\$9.80	\$14.85	\$0.00	\$56.83

**Notes:**

**Apprentice to Journeyworker Ratio:1:5**

CEMENT MASONRY/PLASTERING <i>BRICKLAYERS LOCAL 3 (BOSTON)</i>	01/01/2015	\$44.90	\$10.90	\$18.71	\$1.30	\$75.81
	07/01/2015	\$45.82	\$10.90	\$18.71	\$1.30	\$76.73
	01/01/2016	\$46.44	\$10.90	\$18.71	\$1.30	\$77.35



**Classification**

**Effective Date Base Wage Health Pension Supplemental Unemployment Total Rate**

**Apprentice - CEMENT MASONRY/PLASTERING - Eastern Mass (Boston)**

**Effective Date - 01/01/2015**

Step	percent	Apprentice Base Wage	Health	Pension	Supplemental Unemployment	Total Rate
1	50	\$22.45	\$10.90	\$12.21	\$1.30	\$46.86
2	60	\$26.94	\$10.90	\$13.71	\$1.30	\$52.85
3	65	\$29.19	\$10.90	\$14.71	\$1.30	\$56.10
4	70	\$31.43	\$10.90	\$15.71	\$1.30	\$59.34
5	75	\$33.68	\$10.90	\$16.71	\$1.30	\$62.59
6	80	\$35.92	\$10.90	\$17.71	\$1.30	\$65.83
7	90	\$40.41	\$10.90	\$18.71	\$1.30	\$71.32

**Effective Date - 07/01/2015**

Step	percent	Apprentice Base Wage	Health	Pension	Supplemental Unemployment	Total Rate
1	50	\$22.91	\$10.90	\$12.21	\$1.30	\$47.32
2	60	\$27.49	\$10.90	\$13.71	\$1.30	\$53.40
3	65	\$29.78	\$10.90	\$14.71	\$1.30	\$56.69
4	70	\$32.07	\$10.90	\$15.71	\$1.30	\$59.98
5	75	\$34.37	\$10.90	\$16.71	\$1.30	\$63.28
6	80	\$36.66	\$10.90	\$17.71	\$1.30	\$66.57
7	90	\$41.24	\$10.90	\$18.71	\$1.30	\$72.15

**Notes:**

Steps 3,4 are 500 hrs. All other steps are 1,000 hrs.

**Apprentice to Journeyworker Ratio:1:3**

<b>CHAIN SAW OPERATOR</b>	12/01/2014	\$34.85	\$7.30	\$12.95	\$0.00	\$55.10
<i>LABORERS - ZONE 1</i>	06/01/2015	\$35.60	\$7.30	\$12.95	\$0.00	\$55.85
	12/01/2015	\$36.35	\$7.30	\$12.95	\$0.00	\$56.60
	06/01/2016	\$37.10	\$7.30	\$12.95	\$0.00	\$57.35
	12/01/2016	\$38.10	\$7.30	\$12.95	\$0.00	\$58.35

For apprentice rates see "Apprentice- LABORER"

<b>CLAM SHELLS/SLURRY BUCKETS/HEADING MACHINES</b>	12/01/2014	\$43.39	\$10.00	\$14.30	\$0.00	\$67.69
<i>OPERATING ENGINEERS LOCAL 4</i>	06/01/2015	\$44.14	\$10.00	\$14.30	\$0.00	\$68.44
	12/01/2015	\$45.39	\$10.00	\$14.30	\$0.00	\$69.69
	06/01/2016	\$46.14	\$10.00	\$14.30	\$0.00	\$70.44
	12/01/2016	\$47.39	\$10.00	\$14.30	\$0.00	\$71.69
	06/01/2017	\$48.39	\$10.00	\$14.30	\$0.00	\$72.69
	12/01/2017	\$49.39	\$10.00	\$14.30	\$0.00	\$73.69

For apprentice rates see "Apprentice- OPERATING ENGINEERS"

Classification	Effective Date	Base Wage	Health	Pension	Supplemental Unemployment	Total Rate
COMPRESSOR OPERATOR OPERATING ENGINEERS LOCAL 4	12/01/2014	\$29.40	\$10.00	\$14.30	\$0.00	\$53.70
	06/01/2015	\$29.92	\$10.00	\$14.30	\$0.00	\$54.22
	12/01/2015	\$30.79	\$10.00	\$14.30	\$0.00	\$55.09
	06/01/2016	\$31.31	\$10.00	\$14.30	\$0.00	\$55.61
	12/01/2016	\$32.18	\$10.00	\$14.30	\$0.00	\$56.48
	06/01/2017	\$32.87	\$10.00	\$14.30	\$0.00	\$57.17
	12/01/2017	\$33.56	\$10.00	\$14.30	\$0.00	\$57.86

For apprentice rates see "Apprentice- OPERATING ENGINEERS"

DELEADER (BRIDGE) PAINTERS LOCAL 35 - ZONE 2	01/01/2015	\$47.66	\$7.85	\$16.10	\$0.00	\$71.61
	07/01/2015	\$48.56	\$7.85	\$16.10	\$0.00	\$72.51
	01/01/2016	\$49.51	\$7.85	\$16.10	\$0.00	\$73.46
	07/01/2016	\$50.46	\$7.85	\$16.10	\$0.00	\$74.41
	01/01/2017	\$51.41	\$7.85	\$16.10	\$0.00	\$75.36

**Apprentice - PAINTER Local 35 - BRIDGES/TANKS**

**Effective Date - 01/01/2015**

Step	percent	Apprentice Base Wage	Health	Pension	Supplemental Unemployment	Total Rate
1	50	\$23.83	\$7.85	\$0.00	\$0.00	\$31.68
2	55	\$26.21	\$7.85	\$3.66	\$0.00	\$37.72
3	60	\$28.60	\$7.85	\$3.99	\$0.00	\$40.44
4	65	\$30.98	\$7.85	\$4.32	\$0.00	\$43.15
5	70	\$33.36	\$7.85	\$14.11	\$0.00	\$55.32
6	75	\$35.75	\$7.85	\$14.44	\$0.00	\$58.04
7	80	\$38.13	\$7.85	\$14.77	\$0.00	\$60.75
8	90	\$42.89	\$7.85	\$15.44	\$0.00	\$66.18

**Effective Date - 07/01/2015**

Step	percent	Apprentice Base Wage	Health	Pension	Supplemental Unemployment	Total Rate
1	50	\$24.28	\$7.85	\$0.00	\$0.00	\$32.13
2	55	\$26.71	\$7.85	\$3.66	\$0.00	\$38.22
3	60	\$29.14	\$7.85	\$3.99	\$0.00	\$40.98
4	65	\$31.56	\$7.85	\$4.32	\$0.00	\$43.73
5	70	\$33.99	\$7.85	\$14.11	\$0.00	\$55.95
6	75	\$36.42	\$7.85	\$14.44	\$0.00	\$58.71
7	80	\$38.85	\$7.85	\$14.77	\$0.00	\$61.47
8	90	\$43.70	\$7.85	\$15.44	\$0.00	\$66.99

**Notes:**

Steps are 750 hrs.

**Apprentice to Journeyworker Ratio:1:1**

DEMO: ADZEMAN LABORERS - ZONE 1	12/01/2014	\$34.75	\$7.30	\$12.95	\$0.00	\$55.00
	06/01/2015	\$35.50	\$7.30	\$12.95	\$0.00	\$55.75
	12/01/2015	\$36.25	\$7.30	\$12.95	\$0.00	\$56.50

For apprentice rates see "Apprentice- LABORER"

Classification	Effective Date	Base Wage	Health	Pension	Supplemental Unemployment	Total Rate
DEMO: BACKHOE/LOADER/HAMMER OPERATOR <i>LABORERS - ZONE 1</i>	12/01/2014	\$35.75	\$7.30	\$12.95	\$0.00	\$56.00
	06/01/2015	\$36.50	\$7.30	\$12.95	\$0.00	\$56.75
	12/01/2015	\$37.25	\$7.30	\$12.95	\$0.00	\$57.50
For apprentice rates see "Apprentice- LABORER"						
DEMO: BURNERS <i>LABORERS - ZONE 1</i>	12/01/2014	\$35.50	\$7.30	\$12.95	\$0.00	\$55.75
	06/01/2015	\$36.25	\$7.30	\$12.95	\$0.00	\$56.50
	12/01/2015	\$37.00	\$7.30	\$12.95	\$0.00	\$57.25
For apprentice rates see "Apprentice- LABORER"						
DEMO: CONCRETE CUTTER/SAWYER <i>LABORERS - ZONE 1</i>	12/01/2014	\$35.75	\$7.30	\$12.95	\$0.00	\$56.00
	06/01/2015	\$36.50	\$7.30	\$12.95	\$0.00	\$56.75
	12/01/2015	\$37.25	\$7.30	\$12.95	\$0.00	\$57.50
For apprentice rates see "Apprentice- LABORER"						
DEMO: JACKHAMMER OPERATOR <i>LABORERS - ZONE 1</i>	12/01/2014	\$35.50	\$7.30	\$12.95	\$0.00	\$55.75
	06/01/2015	\$36.25	\$7.30	\$12.95	\$0.00	\$56.50
	12/01/2015	\$37.00	\$7.30	\$12.95	\$0.00	\$57.25
For apprentice rates see "Apprentice- LABORER"						
DEMO: WRECKING LABORER <i>LABORERS - ZONE 1</i>	12/01/2014	\$34.75	\$7.30	\$12.95	\$0.00	\$55.00
	06/01/2015	\$35.50	\$7.30	\$12.95	\$0.00	\$55.75
	12/01/2015	\$36.25	\$7.30	\$12.95	\$0.00	\$56.50
For apprentice rates see "Apprentice- LABORER"						
DIRECTIONAL DRILL MACHINE OPERATOR <i>OPERATING ENGINEERS LOCAL 4</i>	12/01/2014	\$41.99	\$10.00	\$14.30	\$0.00	\$66.29
	06/01/2015	\$42.73	\$10.00	\$14.30	\$0.00	\$67.03
	12/01/2015	\$43.97	\$10.00	\$14.30	\$0.00	\$68.27
	06/01/2016	\$44.72	\$10.00	\$14.30	\$0.00	\$69.02
	12/01/2016	\$45.95	\$10.00	\$14.30	\$0.00	\$70.25
	06/01/2017	\$46.94	\$10.00	\$14.30	\$0.00	\$71.24
	12/01/2017	\$47.93	\$10.00	\$14.30	\$0.00	\$72.23
For apprentice rates see "Apprentice- OPERATING ENGINEERS"						
DIVER <i>PILE DRIVER LOCAL 56 (ZONE 1)</i>	08/01/2014	\$58.24	\$9.80	\$18.17	\$0.00	\$86.21
	08/01/2015	\$60.34	\$9.80	\$18.17	\$0.00	\$88.31
DIVER TENDER <i>PILE DRIVER LOCAL 56 (ZONE 1)</i>	08/01/2014	\$41.60	\$9.80	\$18.17	\$0.00	\$69.57
	08/01/2015	\$43.10	\$9.80	\$18.17	\$0.00	\$71.07
DIVER TENDER (EFFLUENT) <i>PILE DRIVER LOCAL 56 (ZONE 1)</i>	08/01/2014	\$62.40	\$9.80	\$18.17	\$0.00	\$90.37
	08/01/2015	\$64.65	\$9.80	\$18.17	\$0.00	\$92.62
DIVER/SLURRY (EFFLUENT) <i>PILE DRIVER LOCAL 56 (ZONE 1)</i>	08/01/2014	\$87.36	\$9.80	\$18.17	\$0.00	\$115.33
	08/01/2015	\$90.51	\$9.80	\$18.17	\$0.00	\$118.48
DRAWBRIDGE OPERATOR (Construction) <i>ELECTRICIANS LOCAL 103</i>	03/01/2015	\$45.17	\$13.00	\$15.40	\$0.00	\$73.57
	09/01/2015	\$46.13	\$13.00	\$15.43	\$0.00	\$74.56
	03/01/2016	\$47.08	\$13.00	\$15.46	\$0.00	\$75.54
For apprentice rates see "Apprentice- ELECTRICIAN"						
ELECTRICIAN <i>ELECTRICIANS LOCAL 103</i>	03/01/2015	\$45.17	\$13.00	\$15.40	\$0.00	\$73.57
	09/01/2015	\$46.13	\$13.00	\$15.43	\$0.00	\$74.56
	03/01/2016	\$47.08	\$13.00	\$15.46	\$0.00	\$75.54

Classification

Effective Date Base Wage Health Pension Supplemental Unemployment Total Rate

Apprentice - *ELECTRICIAN - Local 103*

Effective Date - 03/01/2015

Step	percent	Apprentice Base Wage	Health	Pension	Supplemental Unemployment	Total Rate
1	40	\$18.07	\$13.00	\$0.54	\$0.00	\$31.61
2	40	\$18.07	\$13.00	\$0.54	\$0.00	\$31.61
3	45	\$20.33	\$13.00	\$11.64	\$0.00	\$44.97
4	45	\$20.33	\$13.00	\$11.64	\$0.00	\$44.97
5	50	\$22.59	\$13.00	\$11.98	\$0.00	\$47.57
6	55	\$24.84	\$13.00	\$12.33	\$0.00	\$50.17
7	60	\$27.10	\$13.00	\$12.66	\$0.00	\$52.76
8	65	\$29.36	\$13.00	\$13.01	\$0.00	\$55.37
9	70	\$31.62	\$13.00	\$13.35	\$0.00	\$57.97
10	75	\$33.88	\$13.00	\$13.70	\$0.00	\$60.58

Effective Date - 09/01/2015

Step	percent	Apprentice Base Wage	Health	Pension	Supplemental Unemployment	Total Rate
1	40	\$18.45	\$13.00	\$0.55	\$0.00	\$32.00
2	40	\$18.45	\$13.00	\$0.55	\$0.00	\$32.00
3	45	\$20.76	\$13.00	\$11.65	\$0.00	\$45.41
4	45	\$20.76	\$13.00	\$11.65	\$0.00	\$45.41
5	50	\$23.07	\$13.00	\$11.99	\$0.00	\$48.06
6	55	\$25.37	\$13.00	\$12.34	\$0.00	\$50.71
7	60	\$27.68	\$13.00	\$12.68	\$0.00	\$53.36
8	65	\$29.98	\$13.00	\$13.03	\$0.00	\$56.01
9	70	\$32.29	\$13.00	\$13.37	\$0.00	\$58.66
10	75	\$34.60	\$13.00	\$13.72	\$0.00	\$61.32

Notes :

App Prior 1/1/03; 30/35/40/45/50/55/65/70/75/80

Apprentice to Journeyworker Ratio:2:3\*\*\*

ELEVATOR CONSTRUCTOR ELEVATOR CONSTRUCTORS LOCAL 4	01/01/2012	\$52.45	\$8.78	\$6.96	\$0.00	\$68.19
---	------------	---------	--------	--------	--------	---------

Classification

Effective Date Base Wage Health Pension Supplemental Unemployment Total Rate

**Apprentice - ELEVATOR CONSTRUCTOR - Local 4**

Effective Date - 01/01/2012

Step	percent	Apprentice Base Wage	Health	Pension	Supplemental Unemployment	Total Rate
1	50	\$26.23	\$8.78	\$0.00	\$0.00	\$35.01
2	55	\$28.85	\$8.78	\$6.96	\$0.00	\$44.59
3	65	\$34.09	\$8.78	\$6.96	\$0.00	\$49.83
4	70	\$36.72	\$8.78	\$6.96	\$0.00	\$52.46
5	80	\$41.96	\$8.78	\$6.96	\$0.00	\$57.70

**Notes:**

Steps 1-2 are 6 mos.; Steps 3-5 are 1 year

**Apprentice to Journeyworker Ratio:1:1**

ELEVATOR CONSTRUCTOR HELPER ELEVATOR CONSTRUCTORS LOCAL 4	01/01/2012	\$38.59	\$8.78	\$6.96	\$0.00	\$54.33
--	------------	---------	--------	--------	--------	---------

For apprentice rates see "Apprentice - ELEVATOR CONSTRUCTOR"

FENCE & GUARD RAIL ERECTOR LABORERS - ZONE 1	12/01/2014	\$34.85	\$7.30	\$12.95	\$0.00	\$55.10
	06/01/2015	\$35.60	\$7.30	\$12.95	\$0.00	\$55.85
	12/01/2015	\$36.35	\$7.30	\$12.95	\$0.00	\$56.60
	06/01/2016	\$37.10	\$7.30	\$12.95	\$0.00	\$57.35
	12/01/2016	\$38.10	\$7.30	\$12.95	\$0.00	\$58.35

For apprentice rates see "Apprentice- LABORER"

FIELD ENG.INST.PERSON-BLDG,SITE,HVY/HWY OPERATING ENGINEERS LOCAL 4	11/01/2014	\$39.59	\$10.00	\$14.18	\$0.00	\$63.77
	05/01/2015	\$40.32	\$10.00	\$14.18	\$0.00	\$64.50
	11/01/2015	\$40.90	\$10.00	\$14.18	\$0.00	\$65.08
	05/01/2016	\$41.79	\$10.00	\$14.18	\$0.00	\$65.97
	11/01/2016	\$42.38	\$10.00	\$14.18	\$0.00	\$66.56
	05/01/2017	\$43.26	\$10.00	\$14.18	\$0.00	\$67.44
	11/01/2017	\$43.99	\$10.00	\$14.18	\$0.00	\$68.17
	05/01/2018	\$44.70	\$10.00	\$14.18	\$0.00	\$68.88

For apprentice rates see "Apprentice- OPERATING ENGINEERS"

FIELD ENG.PARTY CHIEF-BLDG,SITE,HVY/HWY OPERATING ENGINEERS LOCAL 4	11/01/2014	\$41.02	\$10.00	\$14.18	\$0.00	\$65.20
	05/01/2015	\$41.75	\$10.00	\$14.18	\$0.00	\$65.93
	11/01/2015	\$42.34	\$10.00	\$14.18	\$0.00	\$66.52
	05/01/2016	\$43.23	\$10.00	\$14.18	\$0.00	\$67.41
	11/01/2016	\$43.83	\$10.00	\$14.18	\$0.00	\$68.01
	05/01/2017	\$44.72	\$10.00	\$14.18	\$0.00	\$68.90
	11/01/2017	\$45.45	\$10.00	\$14.18	\$0.00	\$69.63
	05/01/2018	\$46.17	\$10.00	\$14.18	\$0.00	\$70.35

For apprentice rates see "Apprentice- OPERATING ENGINEERS"

Classification	Effective Date	Base Wage	Health	Pension	Supplemental Unemployment	Total Rate
FIELD ENG.ROD PERSON-BLDG,SITE,HVY/HWY <i>OPERATING ENGINEERS LOCAL 4</i>	11/01/2014	\$21.35	\$10.00	\$14.18	\$0.00	\$45.53
	05/01/2015	\$21.78	\$10.00	\$14.18	\$0.00	\$45.96
	11/01/2015	\$22.12	\$10.00	\$14.18	\$0.00	\$46.30
	05/01/2016	\$22.64	\$10.00	\$14.18	\$0.00	\$46.82
	11/01/2016	\$22.99	\$10.00	\$14.18	\$0.00	\$47.17
	05/01/2017	\$23.52	\$10.00	\$14.18	\$0.00	\$47.70
	11/01/2017	\$23.94	\$10.00	\$14.18	\$0.00	\$48.12
	05/01/2018	\$24.37	\$10.00	\$14.18	\$0.00	\$48.55
For apprentice rates see "Apprentice- OPERATING ENGINEERS"						
FIRE ALARM INSTALLER <i>ELECTRICIANS LOCAL 103</i>	03/01/2015	\$45.17	\$13.00	\$15.40	\$0.00	\$73.57
	09/01/2015	\$46.13	\$13.00	\$15.43	\$0.00	\$74.56
	03/01/2016	\$47.08	\$13.00	\$15.46	\$0.00	\$75.54
For apprentice rates see "Apprentice- ELECTRICIAN"						
FIRE ALARM REPAIR / MAINTENANCE / COMMISSIONING <i>ELECTRICIANS</i> <i>LOCAL 103</i>	03/01/2015	\$33.88	\$13.00	\$13.70	\$0.00	\$60.58
	09/01/2015	\$34.60	\$13.00	\$13.72	\$0.00	\$61.32
	03/01/2016	\$35.31	\$13.00	\$13.74	\$0.00	\$62.05
For apprentice rates see "Apprentice- TELECOMMUNICATIONS TECHNICIAN"						
FIREMAN (ASST. ENGINEER) <i>OPERATING ENGINEERS LOCAL 4</i>	12/01/2014	\$35.33	\$10.00	\$14.30	\$0.00	\$59.63
	06/01/2015	\$35.95	\$10.00	\$14.30	\$0.00	\$60.25
	12/01/2015	\$37.00	\$10.00	\$14.30	\$0.00	\$61.30
	06/01/2016	\$37.62	\$10.00	\$14.30	\$0.00	\$61.92
	12/01/2016	\$38.66	\$10.00	\$14.30	\$0.00	\$62.96
	06/01/2017	\$39.50	\$10.00	\$14.30	\$0.00	\$63.80
	12/01/2017	\$40.33	\$10.00	\$14.30	\$0.00	\$64.63
For apprentice rates see "Apprentice- OPERATING ENGINEERS"						
FLAGGER & SIGNALER <i>LABORERS - ZONE 1</i>	12/01/2014	\$20.50	\$7.30	\$12.95	\$0.00	\$40.75
	06/01/2015	\$20.50	\$7.30	\$12.95	\$0.00	\$40.75
	12/01/2015	\$20.50	\$7.30	\$12.95	\$0.00	\$40.75
	06/01/2016	\$20.50	\$7.30	\$12.95	\$0.00	\$40.75
	12/01/2016	\$20.50	\$7.30	\$12.95	\$0.00	\$40.75
For apprentice rates see "Apprentice- LABORER"						
FLOORCOVERER <i>FLOORCOVERERS LOCAL 2168 ZONE I</i>	09/01/2014	\$40.40	\$9.80	\$17.21	\$0.00	\$67.41

**Classification**

**Effective Date    Base Wage    Health    Pension    Supplemental Unemployment    Total Rate**

**Apprentice - FLOORCOVERER - Local 2168 Zone I**

**Effective Date - 09/01/2014**

Step	percent	Apprentice Base Wage	Health	Pension	Supplemental Unemployment	Total Rate
1	50	\$20.20	\$9.80	\$1.79	\$0.00	\$31.79
2	55	\$22.22	\$9.80	\$1.79	\$0.00	\$33.81
3	60	\$24.24	\$9.80	\$11.84	\$0.00	\$45.88
4	65	\$26.26	\$9.80	\$11.84	\$0.00	\$47.90
5	70	\$28.28	\$9.80	\$13.63	\$0.00	\$51.71
6	75	\$30.30	\$9.80	\$13.63	\$0.00	\$53.73
7	80	\$32.32	\$9.80	\$15.42	\$0.00	\$57.54
8	85	\$34.34	\$9.80	\$15.42	\$0.00	\$59.56

**Notes:**

Steps are 750 hrs.

**Apprentice to Journeyworker Ratio:1:1**

<b>FORK LIFT/CHERRY PICKER</b>	12/01/2014	\$42.39	\$10.00	\$14.30	\$0.00	\$66.69
<i>OPERATING ENGINEERS LOCAL 4</i>	06/01/2015	\$43.14	\$10.00	\$14.30	\$0.00	\$67.44
	12/01/2015	\$44.39	\$10.00	\$14.30	\$0.00	\$68.69
	06/01/2016	\$45.14	\$10.00	\$14.30	\$0.00	\$69.44
	12/01/2016	\$46.39	\$10.00	\$14.30	\$0.00	\$70.69
	06/01/2017	\$47.39	\$10.00	\$14.30	\$0.00	\$71.69
	12/01/2017	\$48.39	\$10.00	\$14.30	\$0.00	\$72.69

For apprentice rates see "Apprentice- OPERATING ENGINEERS"

<b>GENERATOR/LIGHTING PLANT/HEATERS</b>	12/01/2014	\$29.40	\$10.00	\$14.30	\$0.00	\$53.70
<i>OPERATING ENGINEERS LOCAL 4</i>	06/01/2015	\$29.92	\$10.00	\$14.30	\$0.00	\$54.22
	12/01/2015	\$30.79	\$10.00	\$14.30	\$0.00	\$55.09
	06/01/2016	\$31.31	\$10.00	\$14.30	\$0.00	\$55.61
	12/01/2016	\$32.18	\$10.00	\$14.30	\$0.00	\$56.48
	06/01/2017	\$32.87	\$10.00	\$14.30	\$0.00	\$57.17
	12/01/2017	\$33.56	\$10.00	\$14.30	\$0.00	\$57.86

For apprentice rates see "Apprentice- OPERATING ENGINEERS"

<b>GLAZIER (GLASS PLANK/AIR BARRIER/INTERIOR SYSTEMS)</b>	01/01/2015	\$37.16	\$7.85	\$16.10	\$0.00	\$61.11
<i>GLAZIERS LOCAL 35 (ZONE 2)</i>	07/01/2015	\$38.06	\$7.85	\$16.10	\$0.00	\$62.01
	01/01/2016	\$39.01	\$7.85	\$16.10	\$0.00	\$62.96
	07/01/2016	\$39.96	\$7.85	\$16.10	\$0.00	\$63.91
	01/01/2017	\$40.91	\$7.85	\$16.10	\$0.00	\$64.86

**Classification**

**Effective Date    Base Wage    Health    Pension    Supplemental Unemployment    Total Rate**

**Apprentice - GLAZIER - Local 35 Zone 2**

**Effective Date - 01/01/2015**

Step	percent	Apprentice Base Wage	Health	Pension	Supplemental Unemployment	Total Rate
1	50	\$18.58	\$7.85	\$0.00	\$0.00	\$26.43
2	55	\$20.44	\$7.85	\$3.66	\$0.00	\$31.95
3	60	\$22.30	\$7.85	\$3.99	\$0.00	\$34.14
4	65	\$24.15	\$7.85	\$4.32	\$0.00	\$36.32
5	70	\$26.01	\$7.85	\$14.11	\$0.00	\$47.97
6	75	\$27.87	\$7.85	\$14.44	\$0.00	\$50.16
7	80	\$29.73	\$7.85	\$14.77	\$0.00	\$52.35
8	90	\$33.44	\$7.85	\$15.44	\$0.00	\$56.73

**Effective Date - 07/01/2015**

Step	percent	Apprentice Base Wage	Health	Pension	Supplemental Unemployment	Total Rate
1	50	\$19.03	\$7.85	\$0.00	\$0.00	\$26.88
2	55	\$20.93	\$7.85	\$3.66	\$0.00	\$32.44
3	60	\$22.84	\$7.85	\$3.99	\$0.00	\$34.68
4	65	\$24.74	\$7.85	\$4.32	\$0.00	\$36.91
5	70	\$26.64	\$7.85	\$14.11	\$0.00	\$48.60
6	75	\$28.55	\$7.85	\$14.44	\$0.00	\$50.84
7	80	\$30.45	\$7.85	\$14.77	\$0.00	\$53.07
8	90	\$34.25	\$7.85	\$15.44	\$0.00	\$57.54

**Notes:**

Steps are 750 hrs.

**Apprentice to Journeyworker Ratio:1:1**

HOISTING ENGINEER/CRANES/GRADALLS	12/01/2014	\$42.39	\$10.00	\$14.30	\$0.00	\$66.69
OPERATING ENGINEERS LOCAL 4	06/01/2015	\$43.14	\$10.00	\$14.30	\$0.00	\$67.44
	12/01/2015	\$44.39	\$10.00	\$14.30	\$0.00	\$68.69
	06/01/2016	\$45.14	\$10.00	\$14.30	\$0.00	\$69.44
	12/01/2016	\$46.39	\$10.00	\$14.30	\$0.00	\$70.69
	06/01/2017	\$47.39	\$10.00	\$14.30	\$0.00	\$71.69
	12/01/2017	\$48.39	\$10.00	\$14.30	\$0.00	\$72.69



**Classification**

**Effective Date    Base Wage    Health    Pension    Supplemental Unemployment    Total Rate**

**Apprentice - OPERATING ENGINEERS - Local 4**

**Effective Date - 12/01/2014**

Step	percent	Apprentice Base Wage	Health	Pension	Supplemental Unemployment	Total Rate
1	55	\$23.31	\$10.00	\$0.00	\$0.00	\$33.31
2	60	\$25.43	\$10.00	\$14.30	\$0.00	\$49.73
3	65	\$27.55	\$10.00	\$14.30	\$0.00	\$51.85
4	70	\$29.67	\$10.00	\$14.30	\$0.00	\$53.97
5	75	\$31.79	\$10.00	\$14.30	\$0.00	\$56.09
6	80	\$33.91	\$10.00	\$14.30	\$0.00	\$58.21
7	85	\$36.03	\$10.00	\$14.30	\$0.00	\$60.33
8	90	\$38.15	\$10.00	\$14.30	\$0.00	\$62.45

**Effective Date - 06/01/2015**

Step	percent	Apprentice Base Wage	Health	Pension	Supplemental Unemployment	Total Rate
1	55	\$23.73	\$10.00	\$0.00	\$0.00	\$33.73
2	60	\$25.88	\$10.00	\$14.30	\$0.00	\$50.18
3	65	\$28.04	\$10.00	\$14.30	\$0.00	\$52.34
4	70	\$30.20	\$10.00	\$14.30	\$0.00	\$54.50
5	75	\$32.36	\$10.00	\$14.30	\$0.00	\$56.66
6	80	\$34.51	\$10.00	\$14.30	\$0.00	\$58.81
7	85	\$36.67	\$10.00	\$14.30	\$0.00	\$60.97
8	90	\$38.83	\$10.00	\$14.30	\$0.00	\$63.13

**Notes:**

**Apprentice to Journeyworker Ratio:1:6**

HVAC (DUCTWORK)	02/01/2015	\$43.28	\$10.20	\$20.54	\$2.22	\$76.24
<i>SHEETMETAL WORKERS LOCAL 17 - A</i>	08/01/2015	\$44.28	\$10.20	\$20.54	\$2.22	\$77.24
	02/01/2016	\$45.28	\$10.20	\$20.54	\$2.22	\$78.24
	08/01/2016	\$46.43	\$10.20	\$20.54	\$2.22	\$79.39
	02/01/2017	\$47.53	\$10.20	\$20.54	\$2.22	\$80.49
	08/01/2017	\$48.63	\$10.20	\$20.54	\$2.22	\$81.59
	02/01/2018	\$49.78	\$10.20	\$20.54	\$2.22	\$82.74

For apprentice rates see "Apprentice- SHEET METAL WORKER"

HVAC (ELECTRICAL CONTROLS)	03/01/2015	\$45.17	\$13.00	\$15.40	\$0.00	\$73.57
<i>ELECTRICIANS LOCAL 103</i>	09/01/2015	\$46.13	\$13.00	\$15.43	\$0.00	\$74.56
	03/01/2016	\$47.08	\$13.00	\$15.46	\$0.00	\$75.54

For apprentice rates see "Apprentice- ELECTRICIAN"

Classification	Effective Date	Base Wage	Health	Pension	Supplemental Unemployment	Total Rate
HVAC (TESTING AND BALANCING - AIR) SHEETMETAL WORKERS LOCAL 17 - A	02/01/2015	\$43.28	\$10.20	\$20.54	\$2.22	\$76.24
	08/01/2015	\$44.28	\$10.20	\$20.54	\$2.22	\$77.24
	02/01/2016	\$45.28	\$10.20	\$20.54	\$2.22	\$78.24
	08/01/2016	\$46.43	\$10.20	\$20.54	\$2.22	\$79.39
	02/01/2017	\$47.53	\$10.20	\$20.54	\$2.22	\$80.49
	08/01/2017	\$48.63	\$10.20	\$20.54	\$2.22	\$81.59
	02/01/2018	\$49.78	\$10.20	\$20.54	\$2.22	\$82.74
For apprentice rates see "Apprentice- SHEET METAL WORKER"						
HVAC (TESTING AND BALANCING - WATER) PIPEFITTERS LOCAL 537	03/01/2015	\$48.69	\$9.70	\$16.89	\$0.00	\$75.28
	09/01/2015	\$49.69	\$9.70	\$16.89	\$0.00	\$76.28
	03/01/2016	\$50.69	\$9.70	\$16.89	\$0.00	\$77.28
	09/01/2016	\$51.69	\$9.70	\$16.89	\$0.00	\$78.28
	03/01/2017	\$52.69	\$9.70	\$16.89	\$0.00	\$79.28
For apprentice rates see "Apprentice- PIPEFITTER" or "PLUMBER/PIPEFITTER"						
HVAC MECHANIC PIPEFITTERS LOCAL 537	03/01/2015	\$48.69	\$9.70	\$16.89	\$0.00	\$75.28
	09/01/2015	\$49.69	\$9.70	\$16.89	\$0.00	\$76.28
	03/01/2016	\$50.69	\$9.70	\$16.89	\$0.00	\$77.28
	09/01/2016	\$51.69	\$9.70	\$16.89	\$0.00	\$78.28
	03/01/2017	\$52.69	\$9.70	\$16.89	\$0.00	\$79.28
For apprentice rates see "Apprentice- PIPEFITTER" or "PLUMBER/PIPEFITTER"						
HYDRAULIC DRILLS LABORERS - ZONE 1	12/01/2014	\$35.35	\$7.30	\$12.95	\$0.00	\$55.60
	06/01/2015	\$36.10	\$7.30	\$12.95	\$0.00	\$56.35
	12/01/2015	\$36.85	\$7.30	\$12.95	\$0.00	\$57.10
	06/01/2016	\$37.60	\$7.30	\$12.95	\$0.00	\$57.85
	12/01/2016	\$38.60	\$7.30	\$12.95	\$0.00	\$58.85
For apprentice rates see "Apprentice- LABORER"						
INSULATOR (PIPES & TANKS) HEAT & FROST INSULATORS LOCAL 6 (BOSTON)	09/01/2014	\$43.31	\$11.25	\$12.60	\$0.00	\$67.16

**Apprentice - ASBESTOS INSULATOR (Pipes & Tanks) - Local 6 Boston**

Effective Date - 09/01/2014

Step	percent	Apprentice Base Wage	Health	Pension	Supplemental Unemployment	Total Rate
1	50	\$21.66	\$11.25	\$9.35	\$0.00	\$42.26
2	60	\$25.99	\$11.25	\$10.00	\$0.00	\$47.24
3	70	\$30.32	\$11.25	\$10.65	\$0.00	\$52.22
4	80	\$34.65	\$11.25	\$11.30	\$0.00	\$57.20

**Notes:**

Steps are 1 year

**Apprentice to Journeyworker Ratio:1:4**

IRONWORKER/WELDER IRONWORKERS LOCAL 7 (BOSTON AREA)	03/16/2015	\$42.11	\$7.70	\$20.25	\$0.00	\$70.06
--	------------	---------	--------	---------	--------	---------

**Classification**

**Effective Date Base Wage Health Pension Supplemental Unemployment Total Rate**

**Apprentice - IRONWORKER - Local 7 Boston**

**Effective Date - 03/16/2015**

Step	percent	Apprentice Base Wage	Health	Pension	Supplemental Unemployment	Total Rate
1	60	\$25.27	\$7.70	\$20.25	\$0.00	\$53.22
2	70	\$29.48	\$7.70	\$20.25	\$0.00	\$57.43
3	75	\$31.58	\$7.70	\$20.25	\$0.00	\$59.53
4	80	\$33.69	\$7.70	\$20.25	\$0.00	\$61.64
5	85	\$35.79	\$7.70	\$20.25	\$0.00	\$63.74
6	90	\$37.90	\$7.70	\$20.25	\$0.00	\$65.85

**Notes:**

\*\* Structural 1:6; Ornamental 1:4

**Apprentice to Journeyworker Ratio:\*\***

JACKHAMMER & PAVING BREAKER OPERATOR LABORERS - ZONE 1	12/01/2014	\$34.85	\$7.30	\$12.95	\$0.00	\$55.10
	06/01/2015	\$35.60	\$7.30	\$12.95	\$0.00	\$55.85
	12/01/2015	\$36.35	\$7.30	\$12.95	\$0.00	\$56.60
	06/01/2016	\$37.10	\$7.30	\$12.95	\$0.00	\$57.35
	12/01/2016	\$38.10	\$7.30	\$12.95	\$0.00	\$58.35

For apprentice rates see "Apprentice- LABORER"

LABORER LABORERS - ZONE 1	12/01/2014	\$34.60	\$7.30	\$12.95	\$0.00	\$54.85
	06/01/2015	\$35.35	\$7.30	\$12.95	\$0.00	\$55.60
	12/01/2015	\$36.10	\$7.30	\$12.95	\$0.00	\$56.35
	06/01/2016	\$36.85	\$7.30	\$12.95	\$0.00	\$57.10
	12/01/2016	\$37.85	\$7.30	\$12.95	\$0.00	\$58.10

**Apprentice - LABORER - Zone 1**

**Effective Date - 12/01/2014**

Step	percent	Apprentice Base Wage	Health	Pension	Supplemental Unemployment	Total Rate
1	60	\$20.76	\$7.30	\$12.95	\$0.00	\$41.01
2	70	\$24.22	\$7.30	\$12.95	\$0.00	\$44.47
3	80	\$27.68	\$7.30	\$12.95	\$0.00	\$47.93
4	90	\$31.14	\$7.30	\$12.95	\$0.00	\$51.39

**Effective Date - 06/01/2015**

Step	percent	Apprentice Base Wage	Health	Pension	Supplemental Unemployment	Total Rate
1	60	\$21.21	\$7.30	\$12.95	\$0.00	\$41.46
2	70	\$24.75	\$7.30	\$12.95	\$0.00	\$45.00
3	80	\$28.28	\$7.30	\$12.95	\$0.00	\$48.53
4	90	\$31.82	\$7.30	\$12.95	\$0.00	\$52.07

**Notes:**

**Apprentice to Journeyworker Ratio:1:5**

Classification	Effective Date	Base Wage	Health	Pension	Supplemental Unemployment	Total Rate
LABORER: CARPENTER TENDER <i>LABORERS - ZONE 1</i>	12/01/2014	\$34.60	\$7.30	\$12.95	\$0.00	\$54.85
	06/01/2015	\$35.35	\$7.30	\$12.95	\$0.00	\$55.60
	12/01/2015	\$36.10	\$7.30	\$12.95	\$0.00	\$56.35
	06/01/2016	\$36.85	\$7.30	\$12.95	\$0.00	\$57.10
	12/01/2016	\$37.85	\$7.30	\$12.95	\$0.00	\$58.10
For apprentice rates see "Apprentice- LABORER"						
LABORER: CEMENT FINISHER TENDER <i>LABORERS - ZONE 1</i>	12/01/2014	\$34.60	\$7.30	\$12.95	\$0.00	\$54.85
	06/01/2015	\$35.35	\$7.30	\$12.95	\$0.00	\$55.60
	12/01/2015	\$36.10	\$7.30	\$12.95	\$0.00	\$56.35
	06/01/2016	\$36.85	\$7.30	\$12.95	\$0.00	\$57.10
	12/01/2016	\$37.85	\$7.30	\$12.95	\$0.00	\$58.10
For apprentice rates see "Apprentice- LABORER"						
LABORER: HAZARDOUS WASTE/ASBESTOS REMOVER <i>LABORERS - ZONE 1</i>	12/01/2014	\$34.75	\$7.30	\$12.95	\$0.00	\$55.00
	06/01/2015	\$35.50	\$7.30	\$12.95	\$0.00	\$55.75
	12/01/2015	\$36.25	\$7.30	\$12.95	\$0.00	\$56.50
For apprentice rates see "Apprentice- LABORER"						
LABORER: MASON TENDER <i>LABORERS - ZONE 1</i>	12/01/2014	\$34.85	\$7.30	\$12.95	\$0.00	\$55.10
	06/01/2015	\$35.60	\$7.30	\$12.95	\$0.00	\$55.85
	12/01/2015	\$36.35	\$7.30	\$12.95	\$0.00	\$56.60
	06/01/2016	\$37.10	\$7.30	\$12.95	\$0.00	\$57.35
	12/01/2016	\$38.10	\$7.30	\$12.95	\$0.00	\$58.35
For apprentice rates see "Apprentice- LABORER"						
LABORER: MULTI-TRADE TENDER <i>LABORERS - ZONE 1</i>	12/01/2014	\$34.60	\$7.30	\$12.95	\$0.00	\$54.85
	06/01/2015	\$35.35	\$7.30	\$12.95	\$0.00	\$55.60
	12/01/2015	\$36.10	\$7.30	\$12.95	\$0.00	\$56.35
	06/01/2016	\$36.85	\$7.30	\$12.95	\$0.00	\$57.10
	12/01/2016	\$37.85	\$7.30	\$12.95	\$0.00	\$58.10
For apprentice rates see "Apprentice- LABORER"						
LABORER: TREE REMOVER <i>LABORERS - ZONE 1</i>	12/01/2014	\$34.60	\$7.30	\$12.95	\$0.00	\$54.85
	06/01/2015	\$35.35	\$7.30	\$12.95	\$0.00	\$55.60
	12/01/2015	\$36.10	\$7.30	\$12.95	\$0.00	\$56.35
	06/01/2016	\$36.85	\$7.30	\$12.95	\$0.00	\$57.10
	12/01/2016	\$37.85	\$7.30	\$12.95	\$0.00	\$58.10
This classification applies to all tree work associated with the removal of standing trees, and trimming and removal of branches and limbs when the work is not done for a utility company for the purpose of operation, maintenance or repair of utility company equipment. For apprentice rates see "Apprentice- LABORER"						
LASER BEAM OPERATOR <i>LABORERS - ZONE 1</i>	12/01/2014	\$34.85	\$7.30	\$12.95	\$0.00	\$55.10
	06/01/2015	\$35.60	\$7.30	\$12.95	\$0.00	\$55.85
	12/01/2015	\$36.35	\$7.30	\$12.95	\$0.00	\$56.60
	06/01/2016	\$37.10	\$7.30	\$12.95	\$0.00	\$57.35
	12/01/2016	\$38.10	\$7.30	\$12.95	\$0.00	\$58.35
For apprentice rates see "Apprentice- LABORER"						
MARBLE & TILE FINISHERS <i>BRICKLAYERS LOCAL 3 - MARBLE &amp; TILE</i>	02/01/2015	\$37.37	\$10.18	\$17.18	\$0.00	\$64.73
	08/01/2015	\$38.08	\$10.18	\$17.25	\$0.00	\$65.51
	02/01/2016	\$38.53	\$10.18	\$17.25	\$0.00	\$65.96
	08/01/2016	\$39.23	\$10.18	\$17.33	\$0.00	\$66.74
	02/01/2017	\$39.69	\$10.18	\$17.33	\$0.00	\$67.20

**Classification**

**Effective Date   Base Wage   Health   Pension   Supplemental Unemployment   Total Rate**

**Apprentice - MARBLE & TILE FINISHER - Local 3 Marble & Tile**

**Effective Date - 02/01/2015**

Step	percent	Apprentice Base Wage	Health	Pension	Supplemental Unemployment	Total Rate
1	50	\$18.69	\$10.18	\$17.18	\$0.00	\$46.05
2	60	\$22.42	\$10.18	\$17.18	\$0.00	\$49.78
3	70	\$26.16	\$10.18	\$17.18	\$0.00	\$53.52
4	80	\$29.90	\$10.18	\$17.18	\$0.00	\$57.26
5	90	\$33.63	\$10.18	\$17.18	\$0.00	\$60.99

**Effective Date - 08/01/2015**

Step	percent	Apprentice Base Wage	Health	Pension	Supplemental Unemployment	Total Rate
1	50	\$19.04	\$10.18	\$17.25	\$0.00	\$46.47
2	60	\$22.85	\$10.18	\$17.25	\$0.00	\$50.28
3	70	\$26.66	\$10.18	\$17.25	\$0.00	\$54.09
4	80	\$30.46	\$10.18	\$17.25	\$0.00	\$57.89
5	90	\$34.27	\$10.18	\$17.25	\$0.00	\$61.70

**Notes:**

**Apprentice to Journeyworker Ratio:1:3**

MARBLE MASONS, TILELAYERS & TERRAZZO MECH	02/01/2015	\$49.00	\$10.18	\$18.50	\$0.00	\$77.68
BRICKLAYERS LOCAL 3 - MARBLE & TILE	08/01/2015	\$49.90	\$10.18	\$18.57	\$0.00	\$78.65
	02/01/2016	\$50.47	\$10.18	\$18.57	\$0.00	\$79.22
	08/01/2016	\$51.37	\$10.18	\$18.65	\$0.00	\$80.20
	02/01/2017	\$51.94	\$10.18	\$18.65	\$0.00	\$80.77

Classification

Effective Date Base Wage Health Pension Supplemental Unemployment Total Rate

**Apprentice - MARBLE-TILE-TERRAZZO MECHANIC - Local 3 Marble & Tile**

Effective Date - 02/01/2015

Step	percent	Apprentice Base Wage	Health	Pension	Supplemental Unemployment	Total Rate
1	50	\$24.50	\$10.18	\$18.50	\$0.00	\$53.18
2	60	\$29.40	\$10.18	\$18.50	\$0.00	\$58.08
3	70	\$34.30	\$10.18	\$18.50	\$0.00	\$62.98
4	80	\$39.20	\$10.18	\$18.50	\$0.00	\$67.88
5	90	\$44.10	\$10.18	\$18.50	\$0.00	\$72.78

Effective Date - 08/01/2015

Step	percent	Apprentice Base Wage	Health	Pension	Supplemental Unemployment	Total Rate
1	50	\$24.95	\$10.18	\$18.57	\$0.00	\$53.70
2	60	\$29.94	\$10.18	\$18.57	\$0.00	\$58.69
3	70	\$34.93	\$10.18	\$18.57	\$0.00	\$63.68
4	80	\$39.92	\$10.18	\$18.57	\$0.00	\$68.67
5	90	\$44.91	\$10.18	\$18.57	\$0.00	\$73.66

Notes:

**Apprentice to Journeyworker Ratio:1:5**

MECH. SWEEPER OPERATOR (ON CONST. SITES) OPERATING ENGINEERS LOCAL 4	12/01/2014	\$41.99	\$10.00	\$14.30	\$0.00	\$66.29
	06/01/2015	\$42.73	\$10.00	\$14.30	\$0.00	\$67.03
	12/01/2015	\$43.97	\$10.00	\$14.30	\$0.00	\$68.27
	06/01/2016	\$44.72	\$10.00	\$14.30	\$0.00	\$69.02
	12/01/2016	\$45.95	\$10.00	\$14.30	\$0.00	\$70.25
	06/01/2017	\$46.94	\$10.00	\$14.30	\$0.00	\$71.24
	12/01/2017	\$47.93	\$10.00	\$14.30	\$0.00	\$72.23

For apprentice rates see "Apprentice- OPERATING ENGINEERS"

MECHANICS MAINTENANCE OPERATING ENGINEERS LOCAL 4	12/01/2014	\$41.99	\$10.00	\$14.30	\$0.00	\$66.29
	06/01/2015	\$42.73	\$10.00	\$14.30	\$0.00	\$67.03
	12/01/2015	\$43.97	\$10.00	\$14.30	\$0.00	\$68.27
	06/01/2016	\$44.72	\$10.00	\$14.30	\$0.00	\$69.02
	12/01/2016	\$45.95	\$10.00	\$14.30	\$0.00	\$70.25
	06/01/2017	\$46.94	\$10.00	\$14.30	\$0.00	\$71.24
	12/01/2017	\$47.93	\$10.00	\$14.30	\$0.00	\$72.23

For apprentice rates see "Apprentice- OPERATING ENGINEERS"

MILLWRIGHT (Zone 1) MILLWRIGHTS LOCAL 1121 - Zone 1	10/01/2014	\$36.68	\$9.80	\$16.21	\$0.00	\$62.69
	04/01/2015	\$37.64	\$9.80	\$16.21	\$0.00	\$63.65

**Classification**

**Effective Date    Base Wage    Health    Pension    Supplemental Unemployment    Total Rate**

**Apprentice - MILLWRIGHT - Local 1121 Zone 1**

**Effective Date - 10/01/2014**

Step	percent	Apprentice Base Wage	Health	Pension	Supplemental Unemployment	Total Rate
1	55	\$20.17	\$9.80	\$4.48	\$0.00	\$34.45
2	65	\$23.84	\$9.80	\$13.36	\$0.00	\$47.00
3	75	\$27.51	\$9.80	\$14.18	\$0.00	\$51.49
4	85	\$31.18	\$9.80	\$14.99	\$0.00	\$55.97

**Effective Date - 04/01/2015**

Step	percent	Apprentice Base Wage	Health	Pension	Supplemental Unemployment	Total Rate
1	55	\$20.70	\$9.80	\$4.48	\$0.00	\$34.98
2	65	\$24.47	\$9.80	\$13.36	\$0.00	\$47.63
3	75	\$28.23	\$9.80	\$14.18	\$0.00	\$52.21
4	85	\$31.99	\$9.80	\$14.99	\$0.00	\$56.78

**Notes:**

Steps are 2,000 hours

**Apprentice to Journeyworker Ratio:1:5**

<b>MORTAR MIXER</b> <i>LABORERS - ZONE 1</i>	12/01/2014	\$34.85	\$7.30	\$12.95	\$0.00	\$55.10
	06/01/2015	\$35.60	\$7.30	\$12.95	\$0.00	\$55.85
	12/01/2015	\$36.35	\$7.30	\$12.95	\$0.00	\$56.60
	06/01/2016	\$37.10	\$7.30	\$12.95	\$0.00	\$57.35
	12/01/2016	\$38.10	\$7.30	\$12.95	\$0.00	\$58.35

For apprentice rates see "Apprentice- LABORER"

<b>OILER (OTHER THAN TRUCK CRANES,GRADALLS)</b> <i>OPERATING ENGINEERS LOCAL 4</i>	12/01/2014	\$21.90	\$10.00	\$14.30	\$0.00	\$46.20
	06/01/2015	\$22.28	\$10.00	\$14.30	\$0.00	\$46.58
	12/01/2015	\$22.93	\$10.00	\$14.30	\$0.00	\$47.23
	06/01/2016	\$23.32	\$10.00	\$14.30	\$0.00	\$47.62
	12/01/2016	\$23.97	\$10.00	\$14.30	\$0.00	\$48.27
	06/01/2017	\$24.48	\$10.00	\$14.30	\$0.00	\$48.78
	12/01/2017	\$25.00	\$10.00	\$14.30	\$0.00	\$49.30

For apprentice rates see "Apprentice- OPERATING ENGINEERS"

<b>OILER (TRUCK CRANES, GRADALLS)</b> <i>OPERATING ENGINEERS LOCAL 4</i>	12/01/2014	\$25.54	\$10.00	\$14.30	\$0.00	\$49.84
	06/01/2015	\$25.99	\$10.00	\$14.30	\$0.00	\$50.29
	12/01/2015	\$26.74	\$10.00	\$14.30	\$0.00	\$51.04
	06/01/2016	\$27.20	\$10.00	\$14.30	\$0.00	\$51.50
	12/01/2016	\$27.95	\$10.00	\$14.30	\$0.00	\$52.25
	06/01/2017	\$28.55	\$10.00	\$14.30	\$0.00	\$52.85
	12/01/2017	\$29.16	\$10.00	\$14.30	\$0.00	\$53.46

For apprentice rates see "Apprentice- OPERATING ENGINEERS"

Classification	Effective Date	Base Wage	Health	Pension	Supplemental Unemployment	Total Rate
OTHER POWER DRIVEN EQUIPMENT - CLASS II <i>OPERATING ENGINEERS LOCAL 4</i>	12/01/2014	\$41.99	\$10.00	\$14.30	\$0.00	\$66.29
	06/01/2015	\$42.73	\$10.00	\$14.30	\$0.00	\$67.03
	12/01/2015	\$43.97	\$10.00	\$14.30	\$0.00	\$68.27
	06/01/2016	\$44.72	\$10.00	\$14.30	\$0.00	\$69.02
	12/01/2016	\$45.95	\$10.00	\$14.30	\$0.00	\$70.25
	06/01/2017	\$46.94	\$10.00	\$14.30	\$0.00	\$71.24
	12/01/2017	\$47.93	\$10.00	\$14.30	\$0.00	\$72.23

For apprentice rates see "Apprentice- OPERATING ENGINEERS"

PAINTER (BRIDGES/TANKS) <i>PAINTERS LOCAL 35 - ZONE 2</i>	01/01/2015	\$47.66	\$7.85	\$16.10	\$0.00	\$71.61
	07/01/2015	\$48.56	\$7.85	\$16.10	\$0.00	\$72.51
	01/01/2016	\$49.51	\$7.85	\$16.10	\$0.00	\$73.46
	07/01/2016	\$50.46	\$7.85	\$16.10	\$0.00	\$74.41
	01/01/2017	\$51.41	\$7.85	\$16.10	\$0.00	\$75.36

**Apprentice - PAINTER Local 35 - BRIDGES/TANKS**

**Effective Date - 01/01/2015**

Step	percent	Apprentice Base Wage	Health	Pension	Supplemental Unemployment	Total Rate
1	50	\$23.83	\$7.85	\$0.00	\$0.00	\$31.68
2	55	\$26.21	\$7.85	\$3.66	\$0.00	\$37.72
3	60	\$28.60	\$7.85	\$3.99	\$0.00	\$40.44
4	65	\$30.98	\$7.85	\$4.32	\$0.00	\$43.15
5	70	\$33.36	\$7.85	\$14.11	\$0.00	\$55.32
6	75	\$35.75	\$7.85	\$14.44	\$0.00	\$58.04
7	80	\$38.13	\$7.85	\$14.77	\$0.00	\$60.75
8	90	\$42.89	\$7.85	\$15.44	\$0.00	\$66.18

**Effective Date - 07/01/2015**

Step	percent	Apprentice Base Wage	Health	Pension	Supplemental Unemployment	Total Rate
1	50	\$24.28	\$7.85	\$0.00	\$0.00	\$32.13
2	55	\$26.71	\$7.85	\$3.66	\$0.00	\$38.22
3	60	\$29.14	\$7.85	\$3.99	\$0.00	\$40.98
4	65	\$31.56	\$7.85	\$4.32	\$0.00	\$43.73
5	70	\$33.99	\$7.85	\$14.11	\$0.00	\$55.95
6	75	\$36.42	\$7.85	\$14.44	\$0.00	\$58.71
7	80	\$38.85	\$7.85	\$14.77	\$0.00	\$61.47
8	90	\$43.70	\$7.85	\$15.44	\$0.00	\$66.99

**Notes:**

Steps are 750 hrs.

**Apprentice to Journeyworker Ratio:1:1**

PAINTER (SPRAY OR SANDBLAST, NEW) * * If 30% or more of surfaces to be painted are new construction, NEW paint rate shall be used. <i>PAINTERS LOCAL 35 - ZONE 2</i>	01/01/2015	\$38.56	\$7.85	\$16.10	\$0.00	\$62.51
	07/01/2015	\$39.46	\$7.85	\$16.10	\$0.00	\$63.41
	01/01/2016	\$40.41	\$7.85	\$16.10	\$0.00	\$64.36
	07/01/2016	\$41.36	\$7.85	\$16.10	\$0.00	\$65.31
	01/01/2017	\$42.31	\$7.85	\$16.10	\$0.00	\$66.26



**Classification**

**Effective Date    Base Wage    Health    Pension    Supplemental Unemployment    Total Rate**

**Apprentice - PAINTER Local 35 Zone 2 - Spray/Sandblast - New**

**Effective Date - 01/01/2015**

Step	percent	Apprentice Base Wage	Health	Pension	Supplemental Unemployment	Total Rate
1	50	\$19.28	\$7.85	\$0.00	\$0.00	\$27.13
2	55	\$21.21	\$7.85	\$3.66	\$0.00	\$32.72
3	60	\$23.14	\$7.85	\$3.99	\$0.00	\$34.98
4	65	\$25.06	\$7.85	\$4.32	\$0.00	\$37.23
5	70	\$26.99	\$7.85	\$14.11	\$0.00	\$48.95
6	75	\$28.92	\$7.85	\$14.44	\$0.00	\$51.21
7	80	\$30.85	\$7.85	\$14.77	\$0.00	\$53.47
8	90	\$34.70	\$7.85	\$15.44	\$0.00	\$57.99

**Effective Date - 07/01/2015**

Step	percent	Apprentice Base Wage	Health	Pension	Supplemental Unemployment	Total Rate
1	50	\$19.73	\$7.85	\$0.00	\$0.00	\$27.58
2	55	\$21.70	\$7.85	\$3.66	\$0.00	\$33.21
3	60	\$23.68	\$7.85	\$3.99	\$0.00	\$35.52
4	65	\$25.65	\$7.85	\$4.32	\$0.00	\$37.82
5	70	\$27.62	\$7.85	\$14.11	\$0.00	\$49.58
6	75	\$29.60	\$7.85	\$14.44	\$0.00	\$51.89
7	80	\$31.57	\$7.85	\$14.77	\$0.00	\$54.19
8	90	\$35.51	\$7.85	\$15.44	\$0.00	\$58.80

**Notes:**

Steps are 750 hrs.

**Apprentice to Journeyworker Ratio:1:1**

PAINTER (SPRAY OR SANDBLAST, REPAINT)	01/01/2015	\$36.62	\$7.85	\$16.10	\$0.00	\$60.57
PAINTERS LOCAL 35 - ZONE 2	07/01/2015	\$37.52	\$7.85	\$16.10	\$0.00	\$61.47
	01/01/2016	\$38.47	\$7.85	\$16.10	\$0.00	\$62.42
	07/01/2016	\$39.42	\$7.85	\$16.10	\$0.00	\$63.37
	01/01/2017	\$40.37	\$7.85	\$16.10	\$0.00	\$64.32

**Classification**

**Effective Date    Base Wage    Health    Pension    Supplemental Unemployment    Total Rate**

**Apprentice - PAINTER Local 35 Zone 2 - Spray/Sandblast - Repaint**

**Effective Date - 01/01/2015**

Step	percent	Apprentice Base Wage	Health	Pension	Supplemental Unemployment	Total Rate
1	50	\$18.31	\$7.85	\$0.00	\$0.00	\$26.16
2	55	\$20.14	\$7.85	\$3.66	\$0.00	\$31.65
3	60	\$21.97	\$7.85	\$3.99	\$0.00	\$33.81
4	65	\$23.80	\$7.85	\$4.32	\$0.00	\$35.97
5	70	\$25.63	\$7.85	\$14.11	\$0.00	\$47.59
6	75	\$27.47	\$7.85	\$14.44	\$0.00	\$49.76
7	80	\$29.30	\$7.85	\$14.77	\$0.00	\$51.92
8	90	\$32.96	\$7.85	\$15.44	\$0.00	\$56.25

**Effective Date - 07/01/2015**

Step	percent	Apprentice Base Wage	Health	Pension	Supplemental Unemployment	Total Rate
1	50	\$18.76	\$7.85	\$0.00	\$0.00	\$26.61
2	55	\$20.64	\$7.85	\$3.66	\$0.00	\$32.15
3	60	\$22.51	\$7.85	\$3.99	\$0.00	\$34.35
4	65	\$24.39	\$7.85	\$4.32	\$0.00	\$36.56
5	70	\$26.26	\$7.85	\$14.11	\$0.00	\$48.22
6	75	\$28.14	\$7.85	\$14.44	\$0.00	\$50.43
7	80	\$30.02	\$7.85	\$14.77	\$0.00	\$52.64
8	90	\$33.77	\$7.85	\$15.44	\$0.00	\$57.06

**Notes:**

Steps are 750 hrs.

**Apprentice to Journeyworker Ratio:1:1**

PAINTER (TRAFFIC MARKINGS)	12/01/2014	\$34.60	\$7.30	\$12.95	\$0.00	\$54.85
LABORERS - ZONE 1	06/01/2015	\$35.35	\$7.30	\$12.95	\$0.00	\$55.60
	12/01/2015	\$36.10	\$7.30	\$12.95	\$0.00	\$56.35
	06/01/2016	\$36.85	\$7.30	\$12.95	\$0.00	\$57.10
	12/01/2016	\$37.85	\$7.30	\$12.95	\$0.00	\$58.10
For Apprentice rates see "Apprentice- LABORER"						
PAINTER / TAPER (BRUSH, NEW) *	01/01/2015	\$37.16	\$7.85	\$16.10	\$0.00	\$61.11
* If 30% or more of surfaces to be painted are new construction, NEW paint rate shall be used. PAINTERS LOCAL 35 - ZONE 2	07/01/2015	\$38.06	\$7.85	\$16.10	\$0.00	\$62.01
	01/01/2016	\$39.01	\$7.85	\$16.10	\$0.00	\$62.96
	07/01/2016	\$39.96	\$7.85	\$16.10	\$0.00	\$63.91
	01/01/2017	\$40.91	\$7.85	\$16.10	\$0.00	\$64.86

**Classification**

**Effective Date    Base Wage    Health    Pension    Supplemental Unemployment    Total Rate**

**Apprentice - PAINTER - Local 35 Zone 2 - BRUSH NEW**

**Effective Date - 01/01/2015**

Step	percent	Apprentice Base Wage	Health	Pension	Supplemental Unemployment	Total Rate
1	50	\$18.58	\$7.85	\$0.00	\$0.00	\$26.43
2	55	\$20.44	\$7.85	\$3.66	\$0.00	\$31.95
3	60	\$22.30	\$7.85	\$3.99	\$0.00	\$34.14
4	65	\$24.15	\$7.85	\$4.32	\$0.00	\$36.32
5	70	\$26.01	\$7.85	\$14.11	\$0.00	\$47.97
6	75	\$27.87	\$7.85	\$14.44	\$0.00	\$50.16
7	80	\$29.73	\$7.85	\$14.77	\$0.00	\$52.35
8	90	\$33.44	\$7.85	\$15.44	\$0.00	\$56.73

**Effective Date - 07/01/2015**

Step	percent	Apprentice Base Wage	Health	Pension	Supplemental Unemployment	Total Rate
1	50	\$19.03	\$7.85	\$0.00	\$0.00	\$26.88
2	55	\$20.93	\$7.85	\$3.66	\$0.00	\$32.44
3	60	\$22.84	\$7.85	\$3.99	\$0.00	\$34.68
4	65	\$24.74	\$7.85	\$4.32	\$0.00	\$36.91
5	70	\$26.64	\$7.85	\$14.11	\$0.00	\$48.60
6	75	\$28.55	\$7.85	\$14.44	\$0.00	\$50.84
7	80	\$30.45	\$7.85	\$14.77	\$0.00	\$53.07
8	90	\$34.25	\$7.85	\$15.44	\$0.00	\$57.54

**Notes:**

Steps are 750 hrs.

**Apprentice to Journeyworker Ratio:1:1**

PAINTER / TAPER (BRUSH, REPAINT)	01/01/2015	\$35.22	\$7.85	\$16.10	\$0.00	\$59.17
PAINTERS LOCAL 35 - ZONE 2	07/01/2015	\$36.12	\$7.85	\$16.10	\$0.00	\$60.07
	01/01/2016	\$37.07	\$7.85	\$16.10	\$0.00	\$61.02
	07/01/2016	\$38.02	\$7.85	\$16.10	\$0.00	\$61.97
	01/01/2017	\$38.97	\$7.85	\$16.10	\$0.00	\$62.92

**Classification**

**Effective Date    Base Wage    Health    Pension    Supplemental Unemployment    Total Rate**

**Apprentice - PAINTER Local 35 Zone 2 - BRUSH REPAINT**

**Effective Date - 01/01/2015**

Step	percent	Apprentice Base Wage	Health	Pension	Supplemental Unemployment	Total Rate
1	50	\$17.61	\$7.85	\$0.00	\$0.00	\$25.46
2	55	\$19.37	\$7.85	\$3.66	\$0.00	\$30.88
3	60	\$21.13	\$7.85	\$3.99	\$0.00	\$32.97
4	65	\$22.89	\$7.85	\$4.32	\$0.00	\$35.06
5	70	\$24.65	\$7.85	\$14.11	\$0.00	\$46.61
6	75	\$26.42	\$7.85	\$14.44	\$0.00	\$48.71
7	80	\$28.18	\$7.85	\$14.77	\$0.00	\$50.80
8	90	\$31.70	\$7.85	\$15.44	\$0.00	\$54.99

**Effective Date - 07/01/2015**

Step	percent	Apprentice Base Wage	Health	Pension	Supplemental Unemployment	Total Rate
1	50	\$18.06	\$7.85	\$0.00	\$0.00	\$25.91
2	55	\$19.87	\$7.85	\$3.66	\$0.00	\$31.38
3	60	\$21.67	\$7.85	\$3.99	\$0.00	\$33.51
4	65	\$23.48	\$7.85	\$4.32	\$0.00	\$35.65
5	70	\$25.28	\$7.85	\$14.11	\$0.00	\$47.24
6	75	\$27.09	\$7.85	\$14.44	\$0.00	\$49.38
7	80	\$28.90	\$7.85	\$14.77	\$0.00	\$51.52
8	90	\$32.51	\$7.85	\$15.44	\$0.00	\$55.80

**Notes:**

Steps are 750 hrs.

**Apprentice to Journeyworker Ratio:1:1**

PANEL & PICKUP TRUCKS DRIVER TEAMSTERS JOINT COUNCIL NO. 10 ZONE A	12/01/2014	\$32.23	\$9.91	\$9.33	\$0.00	\$51.47
	06/01/2015	\$32.58	\$9.91	\$9.33	\$0.00	\$51.82
	08/01/2015	\$32.58	\$10.41	\$9.33	\$0.00	\$52.32
	12/01/2015	\$32.58	\$10.41	\$10.08	\$0.00	\$53.07
	06/01/2016	\$33.08	\$10.41	\$10.08	\$0.00	\$53.57
	08/01/2016	\$33.08	\$10.91	\$10.08	\$0.00	\$54.07
	12/01/2016	\$33.08	\$10.91	\$10.89	\$0.00	\$54.88
PIER AND DOCK CONSTRUCTOR (UNDERPINNING AND DECK) PILE DRIVER LOCAL 56 (ZONE 1)	08/01/2014	\$41.60	\$9.80	\$18.17	\$0.00	\$69.57
	08/01/2015	\$43.10	\$9.80	\$18.17	\$0.00	\$71.07
PILE DRIVER PILE DRIVER LOCAL 56 (ZONE 1)	08/01/2014	\$41.60	\$9.80	\$18.17	\$0.00	\$69.57
	08/01/2015	\$43.10	\$9.80	\$18.17	\$0.00	\$71.07

**Classification**

**Effective Date   Base Wage   Health   Pension   Supplemental Unemployment   Total Rate**

**Apprentice - PILE DRIVER - Local 56 Zone 1**

**Effective Date - 08/01/2014**

Step	percent	Apprentice Base Wage	Health	Pension	Supplemental Unemployment	Total Rate
1	50	\$20.80	\$9.80	\$18.17	\$0.00	\$48.77
2	60	\$24.96	\$9.80	\$18.17	\$0.00	\$52.93
3	70	\$29.12	\$9.80	\$18.17	\$0.00	\$57.09
4	75	\$31.20	\$9.80	\$18.17	\$0.00	\$59.17
5	80	\$33.28	\$9.80	\$18.17	\$0.00	\$61.25
6	80	\$33.28	\$9.80	\$18.17	\$0.00	\$61.25
7	90	\$37.44	\$9.80	\$18.17	\$0.00	\$65.41
8	90	\$37.44	\$9.80	\$18.17	\$0.00	\$65.41

**Effective Date - 08/01/2015**

Step	percent	Apprentice Base Wage	Health	Pension	Supplemental Unemployment	Total Rate
1	50	\$21.55	\$9.80	\$18.17	\$0.00	\$49.52
2	60	\$25.86	\$9.80	\$18.17	\$0.00	\$53.83
3	70	\$30.17	\$9.80	\$18.17	\$0.00	\$58.14
4	75	\$32.33	\$9.80	\$18.17	\$0.00	\$60.30
5	80	\$34.48	\$9.80	\$18.17	\$0.00	\$62.45
6	80	\$34.48	\$9.80	\$18.17	\$0.00	\$62.45
7	90	\$38.79	\$9.80	\$18.17	\$0.00	\$66.76
8	90	\$38.79	\$9.80	\$18.17	\$0.00	\$66.76

**Notes:**

**Apprentice to Journeyworker Ratio:1:3**

PIPEFITTER & STEAMFITTER	03/01/2015	\$48.69	\$9.70	\$16.89	\$0.00	\$75.28
PIPEFITTERS LOCAL 537	09/01/2015	\$49.69	\$9.70	\$16.89	\$0.00	\$76.28
	03/01/2016	\$50.69	\$9.70	\$16.89	\$0.00	\$77.28
	09/01/2016	\$51.69	\$9.70	\$16.89	\$0.00	\$78.28
	03/01/2017	\$52.69	\$9.70	\$16.89	\$0.00	\$79.28

**Classification**

**Effective Date    Base Wage    Health    Pension    Supplemental Unemployment    Total Rate**

**Apprentice - PIPEFITTER - Local 537**

**Effective Date - 03/01/2015**

Step	percent	Apprentice Base Wage	Health	Pension	Supplemental Unemployment	Total Rate
1	40	\$19.48	\$9.70	\$7.50	\$0.00	\$36.68
2	45	\$21.91	\$9.70	\$16.89	\$0.00	\$48.50
3	60	\$29.21	\$9.70	\$16.89	\$0.00	\$55.80
4	70	\$34.08	\$9.70	\$16.89	\$0.00	\$60.67
5	80	\$38.95	\$9.70	\$16.89	\$0.00	\$65.54

**Effective Date - 09/01/2015**

Step	percent	Apprentice Base Wage	Health	Pension	Supplemental Unemployment	Total Rate
1	40	\$19.88	\$9.70	\$7.50	\$0.00	\$37.08
2	45	\$22.36	\$9.70	\$16.89	\$0.00	\$48.95
3	60	\$29.81	\$9.70	\$16.89	\$0.00	\$56.40
4	70	\$34.78	\$9.70	\$16.89	\$0.00	\$61.37
5	80	\$39.75	\$9.70	\$16.89	\$0.00	\$66.34

**Notes:**

\*\* 1:3; 3:15; 1:10 thereafter / Steps are 1 yr.

Refrig/AC Mechanic \*\*1:1;1:2;2:4;3:6;4:8;5:10;6:12;7:14;8:17;9:20;10:23(Max)

**Apprentice to Journeyworker Ratio:\*\***

PIPELAYER	12/01/2014	\$34.85	\$7.30	\$12.95	\$0.00	\$55.10
LABORERS - ZONE 1	06/01/2015	\$35.60	\$7.30	\$12.95	\$0.00	\$55.85
	12/01/2015	\$36.35	\$7.30	\$12.95	\$0.00	\$56.60
	06/01/2016	\$37.10	\$7.30	\$12.95	\$0.00	\$57.35
	12/01/2016	\$38.10	\$7.30	\$12.95	\$0.00	\$58.35

For apprentice rates see "Apprentice- LABORER"

PLUMBERS & GASFITTERS	03/01/2015	\$50.21	\$10.32	\$14.89	\$0.00	\$75.42
PLUMBERS & GASFITTERS LOCAL 12	09/01/2015	\$51.21	\$10.32	\$14.89	\$0.00	\$76.42
	03/01/2016	\$52.36	\$10.32	\$14.89	\$0.00	\$77.57
	09/01/2016	\$53.41	\$10.32	\$14.89	\$0.00	\$78.62
	03/01/2017	\$54.41	\$10.32	\$14.89	\$0.00	\$79.62

**Classification**

**Effective Date   Base Wage   Health   Pension   Supplemental Unemployment   Total Rate**

**Apprentice - PLUMBER/GASFITTER - Local 12**

**Effective Date - 03/01/2015**

Step	percent	Apprentice Base Wage	Health	Pension	Supplemental Unemployment	Total Rate
1	35	\$17.57	\$10.32	\$5.54	\$0.00	\$33.43
2	40	\$20.08	\$10.32	\$6.27	\$0.00	\$36.67
3	55	\$27.62	\$10.32	\$8.42	\$0.00	\$46.36
4	65	\$32.64	\$10.32	\$9.87	\$0.00	\$52.83
5	75	\$37.66	\$10.32	\$11.30	\$0.00	\$59.28

**Effective Date - 09/01/2015**

Step	percent	Apprentice Base Wage	Health	Pension	Supplemental Unemployment	Total Rate
1	35	\$17.92	\$10.32	\$5.54	\$0.00	\$33.78
2	40	\$20.48	\$10.32	\$6.27	\$0.00	\$37.07
3	55	\$28.17	\$10.32	\$8.42	\$0.00	\$46.91
4	65	\$33.29	\$10.32	\$9.87	\$0.00	\$53.48
5	75	\$38.41	\$10.32	\$11.30	\$0.00	\$60.03

**Notes:**

\*\* 1:2; 2:6; 3:10; 4:14; 5:19/Steps are 1 yr  
Step4 with lic\$56.05 Step5 with lic\$62.48

**Apprentice to Journeyworker Ratio:\*\***

PNEUMATIC CONTROLS (TEMP.) PIPEFITTERS LOCAL 537	03/01/2015	\$48.69	\$9.70	\$16.89	\$0.00	\$75.28
	09/01/2015	\$49.69	\$9.70	\$16.89	\$0.00	\$76.28
	03/01/2016	\$50.69	\$9.70	\$16.89	\$0.00	\$77.28
	09/01/2016	\$51.69	\$9.70	\$16.89	\$0.00	\$78.28
	03/01/2017	\$52.69	\$9.70	\$16.89	\$0.00	\$79.28

For apprentice rates see "Apprentice- PIPEFITTER" or "PLUMBER/PIPEFITTER"

PNEUMATIC DRILL/TOOL OPERATOR LABORERS - ZONE 1	12/01/2014	\$34.85	\$7.30	\$12.95	\$0.00	\$55.10
	06/01/2015	\$35.60	\$7.30	\$12.95	\$0.00	\$55.85
	12/01/2015	\$36.35	\$7.30	\$12.95	\$0.00	\$56.60
	06/01/2016	\$37.10	\$7.30	\$12.95	\$0.00	\$57.35
	12/01/2016	\$38.10	\$7.30	\$12.95	\$0.00	\$58.35

For apprentice rates see "Apprentice- LABORER"

POWDERMAN & BLASTER LABORERS - ZONE 1	12/01/2014	\$35.60	\$7.30	\$12.95	\$0.00	\$55.85
	06/01/2015	\$36.35	\$7.30	\$12.95	\$0.00	\$56.60
	12/01/2015	\$37.10	\$7.30	\$12.95	\$0.00	\$57.35
	06/01/2016	\$37.85	\$7.30	\$12.95	\$0.00	\$58.10
	12/01/2016	\$38.85	\$7.30	\$12.95	\$0.00	\$59.10

For apprentice rates see "Apprentice- LABORER"

Classification	Effective Date	Base Wage	Health	Pension	Supplemental Unemployment	Total Rate
POWER SHOVEL/DERRICK/TRENCHING MACHINE <i>OPERATING ENGINEERS LOCAL 4</i>	12/01/2014	\$42.39	\$10.00	\$14.30	\$0.00	\$66.69
	06/01/2015	\$43.14	\$10.00	\$14.30	\$0.00	\$67.44
	12/01/2015	\$44.39	\$10.00	\$14.30	\$0.00	\$68.69
	06/01/2016	\$45.14	\$10.00	\$14.30	\$0.00	\$69.44
	12/01/2016	\$46.39	\$10.00	\$14.30	\$0.00	\$70.69
	06/01/2017	\$47.39	\$10.00	\$14.30	\$0.00	\$71.69
	12/01/2017	\$48.39	\$10.00	\$14.30	\$0.00	\$72.69
For apprentice rates see "Apprentice- OPERATING ENGINEERS"						
PUMP OPERATOR (CONCRETE) <i>OPERATING ENGINEERS LOCAL 4</i>	12/01/2014	\$42.39	\$10.00	\$14.30	\$0.00	\$66.69
	06/01/2015	\$43.14	\$10.00	\$14.30	\$0.00	\$67.44
	12/01/2015	\$44.39	\$10.00	\$14.30	\$0.00	\$68.69
	06/01/2016	\$45.14	\$10.00	\$14.30	\$0.00	\$69.44
	12/01/2016	\$46.39	\$10.00	\$14.30	\$0.00	\$70.69
	06/01/2017	\$47.39	\$10.00	\$14.30	\$0.00	\$71.69
	12/01/2017	\$48.39	\$10.00	\$14.30	\$0.00	\$72.69
For apprentice rates see "Apprentice- OPERATING ENGINEERS"						
PUMP OPERATOR (DEWATERING, OTHER) <i>OPERATING ENGINEERS LOCAL 4</i>	12/01/2014	\$29.40	\$10.00	\$14.30	\$0.00	\$53.70
	06/01/2015	\$29.92	\$10.00	\$14.30	\$0.00	\$54.22
	12/01/2015	\$30.79	\$10.00	\$14.30	\$0.00	\$55.09
	06/01/2016	\$31.31	\$10.00	\$14.30	\$0.00	\$55.61
	12/01/2016	\$32.18	\$10.00	\$14.30	\$0.00	\$56.48
	06/01/2017	\$32.87	\$10.00	\$14.30	\$0.00	\$57.17
	12/01/2017	\$33.56	\$10.00	\$14.30	\$0.00	\$57.86
For apprentice rates see "Apprentice- OPERATING ENGINEERS"						
READY MIX CONCRETE DRIVERS after 4/30/10 (Drivers Hired After 4/30/2010) <i>TEAMSTERS LOCAL 25c</i>	07/01/2014	\$27.73	\$7.73	\$8.65	\$0.00	\$44.11
	05/01/2015	\$27.88	\$7.73	\$8.92	\$0.00	\$44.53
	07/01/2015	\$27.88	\$7.98	\$8.92	\$0.00	\$44.78
	05/01/2016	\$28.03	\$7.98	\$9.31	\$0.00	\$45.32
	07/01/2016	\$28.03	\$8.23	\$9.31	\$0.00	\$45.57
	05/01/2017	\$28.18	\$8.23	\$9.72	\$0.00	\$46.13
	07/01/2017	\$28.18	\$8.48	\$9.72	\$0.00	\$46.38
READY-MIX CONCRETE DRIVER <i>TEAMSTERS LOCAL 25c</i>	07/01/2014	\$29.03	\$7.73	\$8.65	\$0.00	\$45.41
	05/01/2015	\$29.18	\$7.73	\$8.92	\$0.00	\$45.83
	07/01/2015	\$29.18	\$7.98	\$8.92	\$0.00	\$46.08
	05/01/2016	\$29.33	\$7.98	\$9.31	\$0.00	\$46.62
	07/01/2016	\$29.33	\$8.23	\$9.31	\$0.00	\$46.87
	05/01/2017	\$29.48	\$8.23	\$9.72	\$0.00	\$47.43
	07/01/2017	\$29.48	\$8.48	\$9.72	\$0.00	\$47.68
RECLAIMERS <i>OPERATING ENGINEERS LOCAL 4</i>	12/01/2014	\$41.99	\$10.00	\$14.30	\$0.00	\$66.29
	06/01/2015	\$42.73	\$10.00	\$14.30	\$0.00	\$67.03
	12/01/2015	\$43.97	\$10.00	\$14.30	\$0.00	\$68.27
	06/01/2016	\$44.72	\$10.00	\$14.30	\$0.00	\$69.02
	12/01/2016	\$45.95	\$10.00	\$14.30	\$0.00	\$70.25
	06/01/2017	\$46.94	\$10.00	\$14.30	\$0.00	\$71.24
	12/01/2017	\$47.93	\$10.00	\$14.30	\$0.00	\$72.23
For apprentice rates see "Apprentice- OPERATING ENGINEERS"						



Classification	Effective Date	Base Wage	Health	Pension	Supplemental Unemployment	Total Rate
RESIDENTIAL WOOD FRAME (All Other Work) <i>CARPENTERS -ZONE 2 (Residential Wood)</i>	04/01/2011	\$24.24	\$8.67	\$15.51	\$0.00	\$48.42

RESIDENTIAL WOOD FRAME CARPENTER **	05/01/2011	\$24.24	\$6.34	\$6.23	\$0.00	\$36.81
-------------------------------------	------------	---------	--------	--------	--------	---------

\*\* The Residential Wood Frame Carpenter classification applies only to the construction of new, wood frame residences that do not exceed four stories including the basement. *CARPENTERS -ZONE 2 (Residential Wood)*

As of 9/1/09 Carpentry work on wood-frame residential WEATHERIZATION projects shall be paid the RESIDENTIAL WOOD FRAME CARPENTER rate.

**Apprentice - CARPENTER (Residential Wood Frame) - Zone 2**

Effective Date - 05/01/2011

Step	percent	Apprentice Base Wage	Health	Pension	Supplemental Unemployment	Total Rate
1	60	\$14.54	\$6.34	\$0.00	\$0.00	\$20.88
2	60	\$14.54	\$6.34	\$6.23	\$0.00	\$27.11
3	65	\$15.76	\$6.34	\$6.23	\$0.00	\$28.33
4	70	\$16.97	\$6.34	\$6.23	\$0.00	\$29.54
5	75	\$18.18	\$6.34	\$6.23	\$0.00	\$30.75
6	80	\$19.39	\$6.34	\$6.23	\$0.00	\$31.96
7	85	\$20.60	\$6.34	\$6.23	\$0.00	\$33.17
8	90	\$21.82	\$6.34	\$6.23	\$0.00	\$34.39

**Notes:**

**Apprentice to Journeyworker Ratio:1:5**

RIDE-ON MOTORIZED BUGGY OPERATOR <i>LABORERS - ZONE 1</i>	12/01/2014	\$34.85	\$7.30	\$12.95	\$0.00	\$55.10
	06/01/2015	\$35.60	\$7.30	\$12.95	\$0.00	\$55.85
	12/01/2015	\$36.35	\$7.30	\$12.95	\$0.00	\$56.60
	06/01/2016	\$37.10	\$7.30	\$12.95	\$0.00	\$57.35
	12/01/2016	\$38.10	\$7.30	\$12.95	\$0.00	\$58.35

For apprentice rates see "Apprentice- LABORER"

ROLLER/SPREADER/MULCHING MACHINE <i>OPERATING ENGINEERS LOCAL 4</i>	12/01/2014	\$41.99	\$10.00	\$14.30	\$0.00	\$66.29
	06/01/2015	\$42.73	\$10.00	\$14.30	\$0.00	\$67.03
	12/01/2015	\$43.97	\$10.00	\$14.30	\$0.00	\$68.27
	06/01/2016	\$44.72	\$10.00	\$14.30	\$0.00	\$69.02
	12/01/2016	\$45.95	\$10.00	\$14.30	\$0.00	\$70.25
	06/01/2017	\$46.94	\$10.00	\$14.30	\$0.00	\$71.24
	12/01/2017	\$47.93	\$10.00	\$14.30	\$0.00	\$72.23

For apprentice rates see "Apprentice- OPERATING ENGINEERS"

ROOFER (Inc. Roofer Waterproofing & Roofer Damproofg) <i>ROOFERS LOCAL 33</i>	02/01/2015	\$40.11	\$10.50	\$11.60	\$0.00	\$62.21
	08/01/2015	\$41.01	\$10.50	\$11.60	\$0.00	\$63.11
	02/01/2016	\$41.91	\$10.50	\$11.60	\$0.00	\$64.01

**Classification**

**Effective Date    Base Wage    Health    Pension    Supplemental Unemployment    Total Rate**

**Apprentice - ROOFER - Local 33**

**Effective Date - 02/01/2015**

Step	percent	Apprentice Base Wage	Health	Pension	Supplemental Unemployment	Total Rate
1	50	\$20.06	\$10.50	\$3.38	\$0.00	\$33.94
2	60	\$24.07	\$10.50	\$11.60	\$0.00	\$46.17
3	65	\$26.07	\$10.50	\$11.60	\$0.00	\$48.17
4	75	\$30.08	\$10.50	\$11.60	\$0.00	\$52.18
5	85	\$34.09	\$10.50	\$11.60	\$0.00	\$56.19

**Effective Date - 08/01/2015**

Step	percent	Apprentice Base Wage	Health	Pension	Supplemental Unemployment	Total Rate
1	50	\$20.51	\$10.50	\$3.38	\$0.00	\$34.39
2	60	\$24.61	\$10.50	\$11.60	\$0.00	\$46.71
3	65	\$26.66	\$10.50	\$11.60	\$0.00	\$48.76
4	75	\$30.76	\$10.50	\$11.60	\$0.00	\$52.86
5	85	\$34.86	\$10.50	\$11.60	\$0.00	\$56.96

**Notes: \*\* 1:5, 2:6-10, the 1:10; Reroofing: 1:4, then 1:1**  
 Step 1 is 2000 hrs.; Steps 2-5 are 1000 hrs.

**Apprentice to Journeyworker Ratio:\*\***

ROOFER SLATE / TILE / PRECAST CONCRETE <i>ROOFERS LOCAL 33</i>	02/01/2015	\$40.36	\$10.50	\$11.60	\$0.00	\$62.46
	08/01/2015	\$41.26	\$10.50	\$11.60	\$0.00	\$63.36
	02/01/2016	\$42.16	\$10.50	\$11.60	\$0.00	\$64.26
For apprentice rates see "Apprentice- ROOFER"						
SHEETMETAL WORKER <i>SHEETMETAL WORKERS LOCAL 17 - A</i>	02/01/2015	\$43.28	\$10.20	\$20.54	\$2.22	\$76.24
	08/01/2015	\$44.28	\$10.20	\$20.54	\$2.22	\$77.24
	02/01/2016	\$45.28	\$10.20	\$20.54	\$2.22	\$78.24
	08/01/2016	\$46.43	\$10.20	\$20.54	\$2.22	\$79.39
	02/01/2017	\$47.53	\$10.20	\$20.54	\$2.22	\$80.49
	08/01/2017	\$48.63	\$10.20	\$20.54	\$2.22	\$81.59
	02/01/2018	\$49.78	\$10.20	\$20.54	\$2.22	\$82.74

**Classification**

**Effective Date    Base Wage    Health    Pension    Supplemental Unemployment    Total Rate**

**Apprentice - SHEET METAL WORKER - Local 17-A**

**Effective Date - 02/01/2015**

Step	percent	Apprentice Base Wage	Health	Pension	Supplemental Unemployment	Total Rate
1	40	\$17.31	\$10.20	\$4.58	\$0.00	\$32.09
2	40	\$17.31	\$10.20	\$4.58	\$0.00	\$32.09
3	45	\$19.48	\$10.20	\$9.09	\$1.16	\$39.93
4	45	\$19.48	\$10.20	\$9.09	\$1.16	\$39.93
5	50	\$21.64	\$10.20	\$9.91	\$1.25	\$43.00
6	50	\$21.64	\$10.20	\$10.16	\$1.26	\$43.26
7	60	\$25.97	\$10.20	\$11.55	\$1.43	\$49.15
8	65	\$28.13	\$10.20	\$12.38	\$1.52	\$52.23
9	75	\$32.46	\$10.20	\$14.02	\$1.70	\$58.38
10	85	\$36.79	\$10.20	\$15.16	\$1.86	\$64.01

**Effective Date - 08/01/2015**

Step	percent	Apprentice Base Wage	Health	Pension	Supplemental Unemployment	Total Rate
1	40	\$17.71	\$10.20	\$4.58	\$0.00	\$32.49
2	40	\$17.71	\$10.20	\$4.58	\$0.00	\$32.49
3	45	\$19.93	\$10.20	\$9.09	\$1.18	\$40.40
4	45	\$19.93	\$10.20	\$9.09	\$1.18	\$40.40
5	50	\$22.14	\$10.20	\$9.91	\$1.27	\$43.52
6	50	\$22.14	\$10.20	\$10.16	\$1.28	\$43.78
7	60	\$26.57	\$10.20	\$11.55	\$1.45	\$49.77
8	65	\$28.78	\$10.20	\$12.38	\$1.54	\$52.90
9	75	\$33.21	\$10.20	\$14.02	\$1.72	\$59.15
10	85	\$37.64	\$10.20	\$15.16	\$1.89	\$64.89

**Notes:**  
Steps are 6 mos.

**Apprentice to Journeyworker Ratio:1:4**

SIGN ERECTOR PAINTERS LOCAL 35 - ZONE 2	06/01/2013	\$25.81	\$7.07	\$7.05	\$0.00	\$39.93
--	------------	---------	--------	--------	--------	---------

**Classification**

**Effective Date    Base Wage    Health    Pension    Supplemental Unemployment    Total Rate**

**Apprentice - SIGN ERECTOR - Local 35 Zone 2**

**Effective Date - 06/01/2013**

Step	percent	Apprentice Base Wage	Health	Pension	Supplemental Unemployment	Total Rate
1	50	\$12.91	\$7.07	\$0.00	\$0.00	\$19.98
2	55	\$14.20	\$7.07	\$2.45	\$0.00	\$23.72
3	60	\$15.49	\$7.07	\$2.45	\$0.00	\$25.01
4	65	\$16.78	\$7.07	\$2.45	\$0.00	\$26.30
5	70	\$18.07	\$7.07	\$7.05	\$0.00	\$32.19
6	75	\$19.36	\$7.07	\$7.05	\$0.00	\$33.48
7	80	\$20.65	\$7.07	\$7.05	\$0.00	\$34.77
8	85	\$21.94	\$7.07	\$7.05	\$0.00	\$36.06
9	90	\$23.23	\$7.07	\$7.05	\$0.00	\$37.35

**Notes:**

Steps are 4 mos.

**Apprentice to Journeyworker Ratio:1:1**

SPECIALIZED EARTH MOVING EQUIP < 35 TONS <i>TEAMSTERS JOINT COUNCIL NO. 10 ZONE A</i>	12/01/2014	\$32.69	\$9.91	\$9.33	\$0.00	\$51.93
	06/01/2015	\$33.04	\$9.91	\$9.33	\$0.00	\$52.28
	08/01/2015	\$33.04	\$10.41	\$9.33	\$0.00	\$52.78
	12/01/2015	\$33.04	\$10.41	\$10.08	\$0.00	\$53.53
	06/01/2016	\$33.54	\$10.41	\$10.08	\$0.00	\$54.03
	08/01/2016	\$33.54	\$10.91	\$10.08	\$0.00	\$54.53
	12/01/2016	\$33.54	\$10.91	\$10.89	\$0.00	\$55.34
SPECIALIZED EARTH MOVING EQUIP > 35 TONS <i>TEAMSTERS JOINT COUNCIL NO. 10 ZONE A</i>	12/01/2014	\$32.98	\$9.91	\$9.33	\$0.00	\$52.22
	06/01/2015	\$33.33	\$9.91	\$9.33	\$0.00	\$52.57
	08/01/2015	\$33.33	\$10.41	\$9.33	\$0.00	\$53.07
	12/01/2015	\$33.33	\$10.41	\$10.08	\$0.00	\$53.82
	06/01/2016	\$33.83	\$10.41	\$10.08	\$0.00	\$54.32
	08/01/2016	\$33.83	\$10.91	\$10.08	\$0.00	\$54.82
	12/01/2016	\$33.83	\$10.91	\$10.89	\$0.00	\$55.63
SPRINKLER FITTER <i>SPRINKLER FITTERS LOCAL 550 - (Section A) Zone 1</i>	03/01/2015	\$54.43	\$8.42	\$14.90	\$0.00	\$77.75
	10/01/2015	\$55.58	\$8.42	\$14.90	\$0.00	\$78.90
	01/01/2016	\$55.58	\$8.67	\$15.05	\$0.00	\$79.30
	03/01/2016	\$56.58	\$8.67	\$15.05	\$0.00	\$80.30
	10/01/2016	\$57.73	\$8.67	\$15.05	\$0.00	\$81.45
	03/01/2017	\$58.73	\$8.67	\$15.05	\$0.00	\$82.45

**Classification**

**Effective Date   Base Wage   Health   Pension   Supplemental Unemployment   Total Rate**

**Apprentice - SPRINKLER FITTER - Local 550 (Section A) Zone 1**

**Effective Date - 03/01/2015**

Step	percent	Apprentice Base Wage	Health	Pension	Supplemental Unemployment	Total Rate
1	35	\$19.05	\$8.42	\$8.40	\$0.00	\$35.87
2	40	\$21.77	\$8.42	\$8.40	\$0.00	\$38.59
3	45	\$24.49	\$8.42	\$8.40	\$0.00	\$41.31
4	50	\$27.22	\$8.42	\$8.40	\$0.00	\$44.04
5	55	\$29.94	\$8.42	\$8.40	\$0.00	\$46.76
6	60	\$32.66	\$8.42	\$8.40	\$0.00	\$49.48
7	65	\$35.38	\$8.42	\$8.40	\$0.00	\$52.20
8	70	\$38.10	\$8.42	\$8.40	\$0.00	\$54.92
9	75	\$40.82	\$8.42	\$8.40	\$0.00	\$57.64
10	80	\$43.54	\$8.42	\$8.40	\$0.00	\$60.36

**Effective Date - 10/01/2015**

Step	percent	Apprentice Base Wage	Health	Pension	Supplemental Unemployment	Total Rate
1	35	\$19.45	\$8.42	\$8.40	\$0.00	\$36.27
2	40	\$22.23	\$8.42	\$8.40	\$0.00	\$39.05
3	45	\$25.01	\$8.42	\$8.40	\$0.00	\$41.83
4	50	\$27.79	\$8.42	\$8.40	\$0.00	\$44.61
5	55	\$30.57	\$8.42	\$8.40	\$0.00	\$47.39
6	60	\$33.35	\$8.42	\$8.40	\$0.00	\$50.17
7	65	\$36.13	\$8.42	\$8.40	\$0.00	\$52.95
8	70	\$38.91	\$8.42	\$8.40	\$0.00	\$55.73
9	75	\$41.69	\$8.42	\$8.40	\$0.00	\$58.51
10	80	\$44.46	\$8.42	\$8.40	\$0.00	\$61.28

**Notes:** Apprentice entered prior 9/30/10:  
40/45/50/55/60/65/70/75/80/85  
Steps are 850 hours

**Apprentice to Journeyworker Ratio:1:3**

STEAM BOILER OPERATOR	12/01/2014	\$41.99	\$10.00	\$14.30	\$0.00	\$66.29
OPERATING ENGINEERS LOCAL 4	06/01/2015	\$42.73	\$10.00	\$14.30	\$0.00	\$67.03
	12/01/2015	\$43.97	\$10.00	\$14.30	\$0.00	\$68.27
	06/01/2016	\$44.72	\$10.00	\$14.30	\$0.00	\$69.02
	12/01/2016	\$45.95	\$10.00	\$14.30	\$0.00	\$70.25
	06/01/2017	\$46.94	\$10.00	\$14.30	\$0.00	\$71.24
	12/01/2017	\$47.93	\$10.00	\$14.30	\$0.00	\$72.23

For apprentice rates see "Apprentice- OPERATING ENGINEERS"

Classification	Effective Date	Base Wage	Health	Pension	Supplemental Unemployment	Total Rate
TAMPERS, SELF-PROPELLED OR TRACTOR DRAWN OPERATING ENGINEERS LOCAL 4	12/01/2014	\$41.99	\$10.00	\$14.30	\$0.00	\$66.29
	06/01/2015	\$42.73	\$10.00	\$14.30	\$0.00	\$67.03
	12/01/2015	\$43.97	\$10.00	\$14.30	\$0.00	\$68.27
	06/01/2016	\$44.72	\$10.00	\$14.30	\$0.00	\$69.02
	12/01/2016	\$45.95	\$10.00	\$14.30	\$0.00	\$70.25
	06/01/2017	\$46.94	\$10.00	\$14.30	\$0.00	\$71.24
	12/01/2017	\$47.93	\$10.00	\$14.30	\$0.00	\$72.23
For apprentice rates see "Apprentice- OPERATING ENGINEERS"						
TELECOMMUNICATION TECHNICIAN ELECTRICIANS LOCAL 103	03/01/2015	\$33.88	\$13.00	\$13.70	\$0.00	\$60.58
	09/01/2015	\$34.60	\$13.00	\$13.72	\$0.00	\$61.32
	03/01/2016	\$35.31	\$13.00	\$13.74	\$0.00	\$62.05

**Apprentice - TELECOMMUNICATION TECHNICIAN - Local 103**

**Effective Date - 03/01/2015**

Step	percent	Apprentice Base Wage	Health	Pension	Supplemental Unemployment	Total Rate
1	40	\$13.55	\$13.00	\$0.41	\$0.00	\$26.96
2	40	\$13.55	\$13.00	\$0.41	\$0.00	\$26.96
3	45	\$15.25	\$13.00	\$10.87	\$0.00	\$39.12
4	45	\$15.25	\$13.00	\$10.87	\$0.00	\$39.12
5	50	\$16.94	\$13.00	\$11.11	\$0.00	\$41.05
6	55	\$18.63	\$13.00	\$11.38	\$0.00	\$43.01
7	60	\$20.33	\$13.00	\$11.64	\$0.00	\$44.97
8	65	\$22.02	\$13.00	\$11.89	\$0.00	\$46.91
9	70	\$23.72	\$13.00	\$12.15	\$0.00	\$48.87
10	75	\$25.41	\$13.00	\$12.41	\$0.00	\$50.82

**Effective Date - 09/01/2015**

Step	percent	Apprentice Base Wage	Health	Pension	Supplemental Unemployment	Total Rate
1	40	\$13.84	\$13.00	\$0.42	\$0.00	\$27.26
2	40	\$13.84	\$13.00	\$0.42	\$0.00	\$27.26
3	45	\$15.57	\$13.00	\$10.88	\$0.00	\$39.45
4	45	\$15.57	\$13.00	\$10.88	\$0.00	\$39.45
5	50	\$17.30	\$13.00	\$11.14	\$0.00	\$41.44
6	55	\$19.03	\$13.00	\$11.39	\$0.00	\$43.42
7	60	\$20.76	\$13.00	\$11.65	\$0.00	\$45.41
8	65	\$22.49	\$13.00	\$11.90	\$0.00	\$47.39
9	70	\$24.22	\$13.00	\$12.17	\$0.00	\$49.39
10	75	\$25.95	\$13.00	\$12.43	\$0.00	\$51.38

**Notes:**

**Apprentice to Journeyworker Ratio:1:1**

Classification	Effective Date	Base Wage	Health	Pension	Supplemental Unemployment	Total Rate
TERRAZZO FINISHERS BRICKLAYERS LOCAL 3 - MARBLE & TILE	02/01/2015	\$47.90	\$10.18	\$18.50	\$0.00	\$76.58
	08/01/2015	\$48.80	\$10.18	\$18.57	\$0.00	\$77.55
	02/01/2016	\$49.37	\$10.18	\$18.57	\$0.00	\$78.12
	08/01/2016	\$50.27	\$10.18	\$18.65	\$0.00	\$79.10
	02/01/2017	\$50.84	\$10.18	\$18.65	\$0.00	\$79.67

**Apprentice - TERRAZZO FINISHER - Local 3 Marble & Tile**

**Effective Date - 02/01/2015**

Step	percent	Apprentice Base Wage	Health	Pension	Supplemental Unemployment	Total Rate
1	50	\$23.95	\$10.18	\$18.50	\$0.00	\$52.63
2	60	\$28.74	\$10.18	\$18.50	\$0.00	\$57.42
3	70	\$33.53	\$10.18	\$18.50	\$0.00	\$62.21
4	80	\$38.32	\$10.18	\$18.50	\$0.00	\$67.00
5	90	\$43.11	\$10.18	\$18.50	\$0.00	\$71.79

**Effective Date - 08/01/2015**

Step	percent	Apprentice Base Wage	Health	Pension	Supplemental Unemployment	Total Rate
1	50	\$24.40	\$10.18	\$18.57	\$0.00	\$53.15
2	60	\$29.28	\$10.18	\$18.57	\$0.00	\$58.03
3	70	\$34.16	\$10.18	\$18.57	\$0.00	\$62.91
4	80	\$39.04	\$10.18	\$18.57	\$0.00	\$67.79
5	90	\$43.92	\$10.18	\$18.57	\$0.00	\$72.67

**Notes:**

**Apprentice to Journeyworker Ratio:1:3**

TEST BORING DRILLER LABORERS - FOUNDATION AND MARINE	12/01/2014	\$35.95	\$7.30	\$13.15	\$0.00	\$56.40
	06/01/2015	\$36.70	\$7.30	\$13.15	\$0.00	\$57.15
	12/01/2015	\$37.45	\$7.30	\$13.15	\$0.00	\$57.90
	06/01/2016	\$38.20	\$7.30	\$13.15	\$0.00	\$58.65
	12/01/2016	\$39.20	\$7.30	\$13.15	\$0.00	\$59.65

For apprentice rates see "Apprentice- LABORER"

TEST BORING DRILLER HELPER LABORERS - FOUNDATION AND MARINE	12/01/2014	\$34.67	\$7.30	\$13.15	\$0.00	\$55.12
	06/01/2015	\$35.42	\$7.30	\$13.15	\$0.00	\$55.87
	12/01/2015	\$36.17	\$7.30	\$13.15	\$0.00	\$56.62
	06/01/2016	\$36.92	\$7.30	\$13.15	\$0.00	\$57.37
	12/01/2016	\$37.92	\$7.30	\$13.15	\$0.00	\$58.37

For apprentice rates see "Apprentice- LABORER"

TEST BORING LABORER LABORERS - FOUNDATION AND MARINE	12/01/2014	\$34.55	\$7.30	\$13.15	\$0.00	\$55.00
	06/01/2015	\$35.30	\$7.30	\$13.15	\$0.00	\$55.75
	12/01/2015	\$36.05	\$7.30	\$13.15	\$0.00	\$56.50
	06/01/2016	\$36.80	\$7.30	\$13.15	\$0.00	\$57.25
	12/01/2016	\$37.80	\$7.30	\$13.15	\$0.00	\$58.25

For apprentice rates see "Apprentice- LABORER"

Classification	Effective Date	Base Wage	Health	Pension	Supplemental Unemployment	Total Rate
TRACTORS/PORTABLE STEAM GENERATORS <i>OPERATING ENGINEERS LOCAL 4</i>	12/01/2014	\$41.99	\$10.00	\$14.30	\$0.00	\$66.29
	06/01/2015	\$42.73	\$10.00	\$14.30	\$0.00	\$67.03
	12/01/2015	\$43.97	\$10.00	\$14.30	\$0.00	\$68.27
	06/01/2016	\$44.72	\$10.00	\$14.30	\$0.00	\$69.02
	12/01/2016	\$45.95	\$10.00	\$14.30	\$0.00	\$70.25
	06/01/2017	\$46.94	\$10.00	\$14.30	\$0.00	\$71.24
	12/01/2017	\$47.93	\$10.00	\$14.30	\$0.00	\$72.23
For apprentice rates see "Apprentice- OPERATING ENGINEERS"						
TRAILERS FOR EARTH MOVING EQUIPMENT <i>TEAMSTERS JOINT COUNCIL NO. 10 ZONE A</i>	12/01/2014	\$33.27	\$9.91	\$9.33	\$0.00	\$52.51
	06/01/2015	\$33.62	\$9.91	\$9.33	\$0.00	\$52.86
	08/01/2015	\$33.62	\$10.41	\$9.33	\$0.00	\$53.36
	12/01/2015	\$33.62	\$10.41	\$10.08	\$0.00	\$54.11
	06/01/2016	\$34.12	\$10.41	\$10.08	\$0.00	\$54.61
	08/01/2016	\$34.12	\$10.91	\$10.08	\$0.00	\$55.11
	12/01/2016	\$34.12	\$10.91	\$10.89	\$0.00	\$55.92
TUNNEL WORK - COMPRESSED AIR <i>LABORERS (COMPRESSED AIR)</i>	12/01/2014	\$46.83	\$7.30	\$13.55	\$0.00	\$67.68
	06/01/2015	\$47.58	\$7.30	\$13.55	\$0.00	\$68.43
	12/01/2015	\$48.33	\$7.30	\$13.55	\$0.00	\$69.18
	06/01/2016	\$49.08	\$7.30	\$13.55	\$0.00	\$69.93
	12/01/2016	\$50.08	\$7.30	\$13.55	\$0.00	\$70.93
For apprentice rates see "Apprentice- LABORER"						
TUNNEL WORK - COMPRESSED AIR (HAZ. WASTE) <i>LABORERS (COMPRESSED AIR)</i>	12/01/2014	\$48.83	\$7.30	\$13.55	\$0.00	\$69.68
	06/01/2015	\$49.58	\$7.30	\$13.55	\$0.00	\$70.43
	12/01/2015	\$50.33	\$7.30	\$13.55	\$0.00	\$71.18
	06/01/2016	\$51.08	\$7.30	\$13.55	\$0.00	\$71.93
	12/01/2016	\$52.08	\$7.30	\$13.55	\$0.00	\$72.93
For apprentice rates see "Apprentice- LABORER"						
TUNNEL WORK - FREE AIR <i>LABORERS (FREE AIR TUNNEL)</i>	12/01/2014	\$38.90	\$7.30	\$13.55	\$0.00	\$59.75
	06/01/2015	\$39.65	\$7.30	\$13.55	\$0.00	\$60.50
	12/01/2015	\$40.40	\$7.30	\$13.55	\$0.00	\$61.25
	06/01/2016	\$41.15	\$7.30	\$13.55	\$0.00	\$62.00
	12/01/2016	\$42.15	\$7.30	\$13.55	\$0.00	\$63.00
For apprentice rates see "Apprentice- LABORER"						
TUNNEL WORK - FREE AIR (HAZ. WASTE) <i>LABORERS (FREE AIR TUNNEL)</i>	12/01/2014	\$40.90	\$7.30	\$13.55	\$0.00	\$61.75
	06/01/2015	\$41.65	\$7.30	\$13.55	\$0.00	\$62.50
	12/01/2015	\$42.40	\$7.30	\$13.55	\$0.00	\$63.25
	06/01/2016	\$43.15	\$7.30	\$13.55	\$0.00	\$64.00
	12/01/2016	\$44.15	\$7.30	\$13.55	\$0.00	\$65.00
For apprentice rates see "Apprentice- LABORER"						
VAC-HAUL <i>TEAMSTERS JOINT COUNCIL NO. 10 ZONE A</i>	12/01/2014	\$32.69	\$9.91	\$9.33	\$0.00	\$51.93
	06/01/2015	\$33.04	\$9.91	\$9.33	\$0.00	\$52.28
	08/01/2015	\$33.04	\$10.41	\$9.33	\$0.00	\$52.78
	12/01/2015	\$33.04	\$10.41	\$10.08	\$0.00	\$53.53
	06/01/2016	\$33.54	\$10.41	\$10.08	\$0.00	\$54.03
	08/01/2016	\$33.54	\$10.91	\$10.08	\$0.00	\$54.53
	12/01/2016	\$33.54	\$10.91	\$10.89	\$0.00	\$55.34



Classification	Effective Date	Base Wage	Health	Pension	Supplemental Unemployment	Total Rate
WAGON DRILL OPERATOR <i>LABORERS - ZONE 1</i>	12/01/2014	\$34.85	\$7.30	\$12.95	\$0.00	\$55.10
	06/01/2015	\$35.60	\$7.30	\$12.95	\$0.00	\$55.85
	12/01/2015	\$36.35	\$7.30	\$12.95	\$0.00	\$56.60
	06/01/2016	\$37.10	\$7.30	\$12.95	\$0.00	\$57.35
	12/01/2016	\$38.10	\$7.30	\$12.95	\$0.00	\$58.35
For apprentice rates see "Apprentice- LABORER"						
WASTE WATER PUMP OPERATOR <i>OPERATING ENGINEERS LOCAL 4</i>	12/01/2014	\$42.39	\$10.00	\$14.30	\$0.00	\$66.69
	06/01/2015	\$43.14	\$10.00	\$14.30	\$0.00	\$67.44
	12/01/2015	\$44.39	\$10.00	\$14.30	\$0.00	\$68.69
	06/01/2016	\$45.14	\$10.00	\$14.30	\$0.00	\$69.44
	12/01/2016	\$46.39	\$10.00	\$14.30	\$0.00	\$70.69
	06/01/2017	\$47.39	\$10.00	\$14.30	\$0.00	\$71.69
For apprentice rates see "Apprentice- OPERATING ENGINEERS"						
WATER METER INSTALLER <i>PLUMBERS &amp; GASFITTERS LOCAL 12</i>	03/01/2015	\$50.21	\$10.32	\$14.89	\$0.00	\$75.42
	09/01/2015	\$51.21	\$10.32	\$14.89	\$0.00	\$76.42
	03/01/2016	\$52.36	\$10.32	\$14.89	\$0.00	\$77.57
	09/01/2016	\$53.41	\$10.32	\$14.89	\$0.00	\$78.62
	03/01/2017	\$54.41	\$10.32	\$14.89	\$0.00	\$79.62
For apprentice rates see "Apprentice- PLUMBER/PIPEFITTER" or "PLUMBER/GASFITTER"						

Additional Apprentice Information:

Minimum wage rates for apprentices employed on public works projects are listed above as a percentage of the pre-determined hourly wage rate established by the Commissioner under the provisions of the M.G.L. c. 149, ss. 26-27D. Apprentice ratios are established by the Division of Apprenticeship Training pursuant to M.G.L. c. 23, ss. 11E-11L.

All apprentices must be registered with the Division of Apprenticeship Training in accordance with M.G.L. c. 23, ss. 11E-11L.

All steps are six months (1000 hours.)

Ratios are expressed in allowable number of apprentices to journeymen or fraction thereof, unless otherwise specified.

\*\* Multiple ratios are listed in the comment field.

\*\*\* APP to JM; 1:1, 2:2, 2:3, 3:4, 4:4, 4:5, 4:6, 5:7, 6:7, 6:8, 6:9, 7:10, 8:10, 8:11, 8:12, 9:13, 10:13, 10:14, etc.

\*\*\*\* APP to JM; 1:1, 1:2, 2:3, 2:4, 3:5, 4:6, 4:7, 5:8, 6:9, 6:10, 7:11, 8:12, 8:13, 9:14, 10:15, 10:16, etc.

CONSOLIDATED GENERAL CONDITIONS  
OF THE CONTRACT FOR CONSTRUCTION

ARTICLE 1

GENERAL PROVISIONS

1.1 BASIC DEFINITIONS

1.1.1 THE CONTRACT DOCUMENTS

The Contract Documents consist of the Agreement between Owner and Contractor (hereinafter the Agreement), the Consolidated General Conditions of the Contract for Construction, the Supplemental Statutory Conditions, Drawings, Specifications, including all numbered sections, Addenda issued prior to execution of the Contract, Instructions to Bidders and Proposal, other documents listed in the Agreement, and Modifications issued after execution of the Contract. A Modification is (1) a written amendment to the Contract signed by both parties, (2) a Change Order, (3) a Construction Change Directive or (4) a written order for a minor change in the Work issued by the Architect. Unless specifically enumerated in the Agreement, the Contract Documents do not include other documents such as bidding requirements (advertisement or invitation to bid, Instructions to Bidders, sample forms, the Contractor's bid or portions of addenda relating to bidding requirements).

In the event of any conflict among the Contract Documents, the Documents shall be construed according to the following priorities:

Highest Priority:	Modifications
Second Priority:	Agreement
Third Priority:	Addenda—later date to take precedence
Fourth Priority:	Supplemental Statutory Conditions
Fifth Priority:	Consolidated General Conditions
Sixth Priority:	Specifications and Drawings
Seventh Priority:	Instructions to Bidders and Proposal

Any references throughout the contract documents (or any other project documents) to "General Conditions" or "Supplementary General Conditions" are deleted and "Consolidated General Conditions and Supplemental Statutory Conditions" is substituted therefor. All bidders and sub-bidders take note that the Town has consolidated and modified former versions of the standard form AIA Document A210 General Conditions of the Contract for Construction with the Town's desired Supplementary General Conditions into one document. The Supplemental Statutory Conditions remain intact and separate, and form a part of the Contract Documents.

## 1.1.2 THE CONTRACT

The Contract Documents form the Contract for Construction. The Contract represents the entire and integrated agreement between the parties hereto and supersedes prior negotiations, representations or agreements, either written or oral. The Contract may be amended or modified only by a Modification. Except as provided in Paragraph 3.18, nothing contained in the Contract Documents shall be construed to create any contractual relationship (1) between the Architect and the Contractor, (2) between the Owner or the Architect and a Subcontractor or Sub-subcontractor, (3) between the Owner and the Architect, or (4) between any persons or entities other than the Owner and the Contractor. The Contract Documents shall comply with the requirements of Mass. Gen. Laws Chapter 44, Section 31C.

## 1.1.3 THE WORK

The term "Work" means the construction and services required by the Contract Documents, whether completed or partially completed, and includes all other labor, materials, equipment and services provided or to be provided by the Contractor to fulfill the Contractor's obligations. The Work may constitute the whole or a part of the Project.

## 1.1.4 THE PROJECT

The Project is the total construction of which the Work performed under the Contract Documents may be the whole or a part and which may include construction by the Owner or by separate contractors.

## 1.1.5 THE DRAWINGS

The Drawings are the graphic and pictorial portions of the Contract Documents, wherever located and whenever issued, showing the design, location and dimensions of the Work, generally including plans, elevations, sections, details, schedules and diagrams.

## 1.1.6 THE SPECIFICATIONS

The Specifications are that portion of the Contract Documents consisting of the written requirements for materials, equipment, construction systems, standards and workmanship for the Work, and performance of related services.

## 1.1.7 THE PROJECT MANUAL

The Project Manual is the volume usually assembled for the work which may include the bidding requirements, sample forms, Consolidated General Conditions of the Contract and Specifications.

## 1.2 EXECUTION, CORRELATION AND INTENT

1.2.1 The Contract Documents shall be signed by the Owner and Contractor as provided in the Agreement. A copy of the signed set shall be deposited with the Architect. If either the Owner or Contractor or both do not sign all the Contract Documents, the Architect shall identify such unsigned Documents upon request.

1.2.2 Execution of the Contract by the Contractor is a representation that the Contractor has visited the site, become familiar with local conditions under which the Work is to be performed, and correlated personal observations with requirements of the Contract Documents. By executing the Contract, the Contractor also certifies, under penalties of perjury, that to the best of his information, knowledge and belief he has complied with all laws of the Commonwealth of Massachusetts relating to taxes.

1.2.3 The intent of the Contract Documents is to include all items necessary for the proper execution and completion of the Work by the Contractor. The Contract Documents are complementary, and what is required by one shall be as binding as if required by all. Performance by the Contractor shall be required only to the extent consistent with the Contract Documents and reasonably inferable from them as being necessary to produce the intended results. All Work mentioned or indicated in the Contract Documents shall be performed by the Contractor as part of this Contract unless it is specifically indicated in the Contract Documents that such Work is to be done by others.

1.2.4 Organization of the Specifications into divisions, sections and articles, and arrangement of Drawings shall not control the Contractor in dividing the Work among Subcontractors or in establishing the extent of Work to be performed by any trade.

1.2.5 Unless otherwise stated in the Contract Documents, words which have well-known technical or construction industry meanings are used in the Contract Documents in accordance with such recognized meanings.

1.2.6 Where codes, standards, requirements and publications of public and private bodies are referred to in the Specifications, references shall be understood to be to the latest revisions prior to the date of receiving bids, except where otherwise indicated.

1.2.7 Where no explicit quality or standards for materials or workmanship are established for Work, such Work or materials is to be of good, workmanlike quality for the intended use and consistent with the quality of the surrounding Work and of the construction of the Project generally.

1.2.8 All manufactured articles, materials, and equipment shall be applied, installed, connected, erected, used, cleaned, and conditioned in accordance with the manufacturer's written or printed directions and instructions unless otherwise indicated in the Contract Documents.

1.2.9 The Mechanical, Electrical and Fire Protection Drawings are diagrammatic only, and are not intended to show the alignment, physical locations or configurations of such Work.

Such Work shall be installed without additional cost to the Owner to clear all obstructions, permit proper clearances for the Work of other trades, and present an orderly appearance where exposed. Prior to beginning such Work, the Contractor shall prepare coordination drawings showing the exact alignment, physical location and configuration of the Mechanical, Electrical and Fire Protection installations and demonstrating to the Contractor's satisfaction that the installations will comply with the preceding sentence.

1.2.10 Exact locations of fixtures and outlets shall be obtained from the Architect as provided in Subparagraph 3.2.5 before the Work is roughed in; Work installed without such information from the Architect shall be relocated at the Contractor's expense.

1.2.11 Test boring or soil test information included with the Contract Documents or otherwise made available to the Contractor was obtained by the Owner for use by the Architect in the design of the Project or Work. The Owner does not hold out such information to the Contractor as an accurate or approximate indication of subsurface conditions, and no claim for extra cost or extension of time resulting from a reliance by the Contractor on such information shall be allowed except as provided in Subparagraph 4.3.6.

### 1.3 OWNERSHIP AND USE OF ARCHITECT'S DRAWINGS, SPECIFICATIONS, AND OTHER DOCUMENTS

1.3.1 The Drawings, Specifications and other documents prepared by the Architect are instruments of the Architect's service through which the Work to be executed by the Contractor is described. The Contractor may retain one contract record set. Neither the Contractor nor any Subcontractor, Sub-subcontractor or material or equipment supplier shall own or claim a copyright in the Drawings, Specifications and other documents prepared by the Architect, and, unless otherwise indicated, and except as provided in the Owner/Architect Agreement for the Project, the Architect shall be deemed the author of them and will retain all common law, statutory and other reserved rights, in addition to the copyright. All copies of them, except the Contractor's record set, shall be returned or suitably accounted for to the Architect, on request, upon completion of the Work. The Drawings, Specifications and other documents prepared by the Architect, and copies thereof furnished to the Contractor, are for use solely with respect to this Project. They are not to be used by the Contractor or any Subcontractor, Sub-subcontractor or material or equipment supplier on other projects or for additions to this Project outside the scope of the Work without the specific written consent of the Owner and Architect. The Contractor, Subcontractors, Sub-subcontractors and material or equipment suppliers are granted a limited license to use and reproduce applicable portions of the Drawings, Specifications and other documents prepared by the Architect appropriate to and for use in the execution of their Work under the Contract Documents. All copies made under this license shall bear the statutory copyright notice, if any, shown on the Drawings, Specifications and other documents prepared by the Architect. Submittal or distribution to meet official regulatory requirements or for other purposes in connection with this Project is not to be construed as publication in derogation of the Architect's copyright or other reserved rights.

Notwithstanding anything herein to the contrary, as between the Owner and Architect, their rights and obligations with respect to the Architect's instruments of service are governed by the provisions of the Owner/Architect Agreement for the Project.

#### 1.4 CAPITALIZATION

1.4.1 Terms capitalized in these General Conditions include those which are (1) specifically defined, (2) the titles of numbered articles and identified references to Paragraphs, Subparagraphs and Clauses in a document or (3) the titles of documents published by the American Institute of Architects.

#### 1.5 INTERPRETATION

1.5.1 In the interest of brevity the Contract Documents frequently omit modifying words such as "all" and "any" and articles such as "the" and "an" but the fact that a modifier or an article is absent from one statement and appears in another is not intended to affect the interpretation of either statement.

### ARTICLE 2

#### OWNER

#### 2.1 DEFINITIONS

2.1.1 The Owner is the person or entity identified as such in the Agreement and is referred to throughout the Contract Documents as if singular in number. From time to time herein the Owner is referred to as the Town.

2.1.2 The Project Manager is the person or entity identified as such in writing by the Owner, at the Owner's option. The Project Manager shall act as the Owner's representative with respect to all matters pertaining to the Project. The duties, responsibilities, and obligations of the Project Manager under this Contract may be modified from time to time by the Town, so long as such modifications do not interfere materially with the Contractor's performance of the Work hereunder, and so long as the Contractor is given notice of any such modifications that affect the Contractor's performance of the Work.

#### 2.2 INFORMATION AND SERVICES REQUIRED OF THE OWNER

2.2.1 The Owner upon reasonable written request shall furnish to the Contractor in writing information which is necessary and relevant for the Contractor to evaluate, give notice of, or enforce mechanic's lien rights. Such information shall include a correct statement of the record legal title to the property on which the Project is located, usually referred to as the site, and the Owner's interest therein at the time of execution of the Agreement.

2.2.2 The Owner shall furnish surveys describing physical characteristics, legal limitations and utility locations for the site of the Project, and a legal description of the site.

2.2.3 Except for permits and fees which are the responsibility of the Contractor under the Contract Documents, the Owner shall secure and pay for necessary approvals, easements, assessments and charges required for construction, use or occupancy of permanent structures, or for permanent changes in existing facilities.

2.2.4 Information or services required of the Owner hereunder shall be furnished by the Owner with reasonable promptness after receipt from the Contractor of a written request for such information or services.

2.2.5 Unless otherwise provided in the Contract Documents, the Contractor will be furnished, free of charge, such copies of Drawings and Project Manuals as are reasonably necessary for execution of the Work.

2.2.6 The foregoing are in addition to other duties and responsibilities of the Owner enumerated herein and especially those in respect to Article 6 (Construction by Owner or by Separate Contractors), Article 9 (Payments and Completion) and Article 11 (Insurance and Bonds).

## 2.3 OWNER'S RIGHT TO STOP THE WORK

2.3.1 If the Contractor fails to correct Work which is not in accordance with the requirements of the Contract Documents as required by Paragraph 12.2 or persistently fails to carry out Work in accordance with the Contract Documents, the Owner, by written order signed by the Project Manager, may order the Contractor to stop the Work, or any portion thereof, until the cause for such order has been eliminated; however, the right of the Owner to stop the Work shall not give rise to a duty on the part of the Owner to exercise this right for the benefit of the Contractor or any other person or entity.

2.3.2 The Owner may order the Contractor in writing to suspend, delay or interrupt all or any part of the Work for such period of time as it may determine to be appropriate for the convenience of the Owner, provided however, that if there is a suspension, delay or interruption ordered by the Owner for fifteen days or more or due to a failure of the Owner to act within the time specified in this Contract, the Owner shall make an adjustment in the Contract Sum for any increase in the cost of performance of this Contract, but shall not include any profit to the Contractor on such increase; and provided further, that the Owner shall not make any adjustment in the Contract Sum under this provision for any suspension, delay, interruption or failure to act to the extent that such is due to any cause for which this Contract provides for an equitable adjustment of the Contract Sum under any other contract provisions.

2.3.3 The Contractor must submit the amount of a claim under Subparagraph 2.3.2 to the Owner in writing as soon as practicable after the end of the suspension, delay, interruption or failure to act and, in any event, not later than 21 days after the end thereof. Except for costs due to a suspension order, the Owner shall not approve any costs in the claim incurred more than twenty days before the Contractor notified the Owner in writing of the act or failure to act involved in the claim.

2.4

OWNER'S RIGHT TO CARRY OUT THE WORK

2.4.1 If the Contractor defaults or neglects to carry out the Work in accordance with the Contract Documents and fails within a seven-day period after receipt of written notice from the Owner to begin and prosecute correction of such default or neglect with diligence and promptness, the Owner may, without prejudice to other remedies the Owner may have, correct such deficiencies. In such case an appropriate Construction Change Directive shall be issued deducting from payments then or thereafter due the Contractor the cost of correcting such deficiencies, including compensation for the Architect's additional services and expenses made necessary by such default, neglect or failure. If payments then or thereafter due the Contractor are not sufficient to cover such amounts, the Contractor shall pay the difference to the Owner.

ARTICLE 3

CONTRACTOR

3.1

DEFINITION

3.1.1 The Contractor is the person or entity identified as such in the Agreement and is referred to throughout the Contract Documents as if singular in number. The term "Contractor" means the Contractor or the Contractor's authorized representative.

3.2

REVIEW OF CONTRACT DOCUMENTS AND FIELD CONDITIONS BY CONTRACTOR

3.2.1 Before starting the Work, and at frequent intervals during the progress thereof, the Contractor shall carefully study and compare the Contract Documents with each other and with any information furnished by the Owner pursuant to Subparagraph 2.2.2 and shall at once report to the Architect any error, inconsistency or omission the Contractor may discover. Any necessary change shall be ordered as provided in Article 7, subject to the requirements of Paragraph 1.2 and other provisions of the Contract Documents. If the Contractor proceeds with the Work without such notice to the Architect, having discovered such errors, inconsistencies or omissions, or if by reasonable study of the Contract Documents the Contractor could have discovered such, the Contractor shall bear all costs arising therefrom.

3.2.2

The Contractor shall take field measurements and verify field conditions and shall carefully compare such field measurements and conditions and other information known to the Contractor with the Contract Documents before commencing activities. Errors, inconsistencies or omissions discovered shall be reported to the Architect at once. Any necessary change shall be ordered as provided in Article 7, subject to the requirements of Paragraph 1.2 and other provisions of the Contract Documents. If the Contractor proceeds with the Work without such notice to the Architect, having discovered such errors, inconsistencies or omissions, the Contractor shall bear all costs arising therefrom.



3.2.3 The Contractor shall perform the Work in accordance with the Contract Documents and any submittals made in accordance with Paragraph 3.12.

3.2.4 The Contractor shall give the Architect timely notice of any additional Drawings, Specifications, or instructions required to define the Work in greater detail, or to permit the proper progress of the Work.

3.2.5 The Contractor shall not proceed with any Work not clearly and consistently defined in detail in the Contract Documents, but shall request additional drawings or instructions from the Architect as provided in Subparagraph 3.2.4. If the Contractor proceeds with such Work without obtaining further Drawings, Specifications or instructions, the Contractor shall correct Work incorrectly done at the Contractor's own expense.

### 3.3 SUPERVISION AND CONSTRUCTION PROCEDURES

3.3.1 The Contractor shall supervise and direct the Work, using the Contractor's best skill and attention. The Contractor shall be solely responsible for, and have control over construction means, methods, techniques, sequences and procedures and for coordinating all portions of the Work under the Contract. Where the Contract Documents refer to particular construction means, methods, techniques, sequences or procedures or indicate or imply that such are to be used in the Work, such mention is intended only to indicate that the operations of the Contractor shall be such as to produce at least the quality of work implied by the operations described, but the actual determination of whether or not the described operations may be safely and suitably employed on the Work shall be the responsibility of the Contractor, who shall notify the Architect in writing of the actual means, methods, techniques, sequences or procedures which will be employed on the Work, if these differ from those mentioned in the Contract Documents. All loss, damage, liability, or cost of correcting defective work arising from the employment of any construction means, methods, techniques, sequences or procedures shall be borne by the Contractor, notwithstanding that such construction means, methods, techniques, sequences or procedures are referred to, indicated or implied by the Contract Documents, unless the Contractor has given timely notice to the Owner and Architect in writing that such means, methods, techniques, sequences or procedures are not safe or suitable, and the Owner has then instructed the Contractor in writing to proceed at the Owner's risk.

3.3.2 The Contractor shall be responsible to the Owner for acts and omissions of the Contractor's employees, Subcontractors and their agents and employees, and other persons performing portions of the Work under a contract with the Contractor.

3.3.3 The Contractor shall not be relieved of obligations to perform the Work in accordance with the Contract Documents either by activities or duties of the Architect in the Architect's administration of the Contract, or by tests, inspections or approvals required or performed by persons other than the Contractor.

3.3.4 The Contractor shall be responsible for inspection of portions of Work already performed under this Contract to determine that such portions are in proper condition to receive subsequent Work.

## 3.4 LABOR AND MATERIALS

3.4.1 Unless otherwise provided in the Contract Documents, the Contractor shall provide and pay for labor, materials, equipment, tools, construction equipment and machinery, water, heat, utilities, transportation, and other facilities and services necessary for proper execution and completion of the Work, whether temporary or permanent and whether or not incorporated or to be incorporated in the Work. The word "provide" shall mean furnish and install completely, including connections, unless otherwise specified.

3.4.2 The Contractor shall enforce strict discipline and good order among the Contractor's employees and other persons carrying out the Contract. The Contractor shall not permit employment of unfit persons or persons not skilled in tasks assigned to them.

## 3.5 WARRANTY

3.5.1 The Contractor warrants to the Owner and Architect that materials and equipment furnished under the Contract will be of good quality and new unless otherwise required or permitted by the Contract Documents; that the Work will be free from defects not inherent in the quality required or permitted, and that the Work will conform with the requirements of the Contract Documents. Work not conforming to these requirements, including substitutions not properly approved and authorized, may be considered defective. The Contractor's warranty excludes remedy for damage or defect occurring after Substantial Completion and caused by abuse, modifications not executed by the Contractor, improper or insufficient maintenance, improper operation, or normal wear and tear under normal usage.

3.5.2 The Contractor shall be responsible for determining that all materials furnished for the Work meet all requirements of the Contract Documents. The Architect may require the Contractor to produce reasonable evidence that a material meets such requirements, such as certified reports of past tests by qualified testing laboratories, reports of studies by qualified experts, or other evidence which, in the opinion of the Architect, would lead to a reasonable certainty that any material used, or proposed to be used in the Work, meets the requirements of the Contract Documents. All such data shall be furnished at the Contractor's expense. This provision shall not require the Contractor to pay for periodic testing of different batches of the same material, unless such testing is specifically required by the Contract Documents to be performed at the Contractor's expense.

3.5.3 If the Contractor proposes to use a material which, while suitable for the intended use, deviates in any way from the detailed requirements of the Contract Documents, the Contractor shall inform the Architect in writing of the nature of such deviations at the time the material is submitted for approval, and shall request written approval of the deviation from the requirements of the Contract Documents, in accordance with the procedures set forth in Mass. Gen. Laws Chapter 30, Section 39I.

3.5.4 In requesting approval of deviations or substitutions, the Contractor shall provide, upon request, evidence leading to a reasonable certainty that the proposed substitution or

deviation meets or exceeds the requirements set forth in Mass. Gen. Laws Chapter 30, Section 39M(b). If, in the opinion of the Architect, the evidence presented by the Contractor does not provide a sufficient basis for such reasonable certainty, the Architect may reject such substitution or deviation.

3.5.5 The Contract Documents are intended to produce a building of consistent character and quality of design. All components of the building including visible items of mechanical and electrical equipment have been selected to have a coordinated design in relation to the overall appearance of the building. The Architect shall judge the design and appearance of proposed substitutes on the basis of their suitability in relation to the overall design of the Project, as well as for their intrinsic merits. The Architect will not approve as equal to materials specified proposed substitutes which, in the Architect's opinion, would be out of character, obtrusive, or otherwise inconsistent with the character or quality of design of the Project. In order to permit coordinated design of color and finishes the Contractor shall, if required by the Architect, furnish the substituted material in any color, finish, texture, or pattern which would have been available from the manufacturer originally specified, at no additional cost to the Owner.

3.5.6 Any additional cost, or any loss or damage arising from the substitution of any material or any method for those originally specified shall be borne by the Contractor, notwithstanding approval or acceptance of such substitution by the Owner or the Architect, unless such substitution was made at the written request or direction of the Owner or the Architect.

3.5.7 The warranty provided in this paragraph 3.5 shall be in addition to and not in limitation of any other warranty required by the Contract Documents or otherwise prescribed by law.

3.5.8 The Contractor shall procure and deliver to the Architect, no later than the date claimed by the Contractor as the date of Substantial Completion, all special warranties required by the Contract Documents. Delivery by the Contractor shall constitute the Contractor's guarantee to the Owner that the warranties shall be performed in accordance with their terms and conditions.

### 3.6 TAXES

3.6.1 The Contractor shall pay sales, consumer, use and similar taxes for the Work or portions thereof provided by the Contractor which are legally enacted when bids are received or negotiations concluded, whether or not yet effective or merely scheduled to go into effect.

### 3.7 PERMITS, FEES AND NOTICES

3.7.1 Unless otherwise provided in the Contract Documents, the Contractor shall secure and pay for the building permit and other permits and governmental fees, licenses and inspections necessary for proper execution and completion of the Work which are customarily secured after execution of the Contract and which are legally required when bids are received or

negotiations concluded. Notwithstanding the foregoing, the Town hereby waives the fee for the Town's building permit for the Project.

3.7.2 The Contractor shall comply with and give notices required by laws, ordinances, rules, regulations and lawful orders of public authorities bearing on performance of the Work.

3.7.3 It is not the Contractor's responsibility to ascertain that the Contract Documents are in accordance with applicable laws, statutes, ordinances, building codes, and rules and regulations. However, if the Contractor observes that portions of the Contract Documents are at variance therewith, the Contractor shall promptly notify the Architect and Owner in writing, and necessary changes shall be accomplished by appropriate Modification.

3.7.4 If the Contractor performs Work knowing it to be contrary to laws, statutes, ordinances, building codes, and rules and regulations without such notice to the Architect and Owner, the Contractor shall assume full responsibility for such Work and shall bear the attributable costs.

3.8 ALLOWANCES

3.8.1-3.8.2 OMITTED.

3.9 SUPERINTENDENCE

3.9.1 The Contractor shall employ a competent superintendent, acceptable to the Owner, and necessary assistants who shall be in attendance at the Project site full time during the progress of the Work until the date of Substantial Completion, and for such additional time thereafter as the Architect may determine to be necessary for the expeditious completion of the Work. The superintendent shall be licensed to act as superintendent in accordance with all applicable laws for projects of this type. The Contractor shall remove the superintendent if requested to do so in writing by the Owner, and shall promptly replace him with a competent person reasonably acceptable to the Owner. The superintendent shall represent the Contractor, and communications given to the superintendent shall be as binding as if given to the Contractor.

3.9.2 The Contractor shall retain a competent Registered Professional Engineer or Registered Land Surveyor, acceptable to the Architect, who shall establish the exterior lines and required elevations of all buildings and structures to be erected on the site and shall establish sufficient lines and grades for the construction of associated Work such as, but not limited to, roads, utilities and site grading. The Engineer or Land Surveyor shall certify as to the actual location of the constructed facilities in relation to property lines, building lines, easements, and other restrictive boundaries.

3.9.3 The Contractor shall establish the building grades, lines, levels, column, wall and partition lines required by the various Subcontractors in laying out their Work.

3.9.4 The Contractor shall coordinate and supervise the Work performed by Subcontractors to the end that the Work is carried out without conflict between trades and so that

no trade, at any time, causes delay to the general progress of the Work. If such delays occur, the Owner may deduct anticipated liquidated damages from the Progress Payments to the Contractor. The Contractor and all Subcontractors shall at all times afford each trade, any separate contractor, or the Owner, every reasonable opportunity for the installation of Work and the storage of materials.

### 3.10 CONTRACTOR'S CONSTRUCTION SCHEDULES

3.10.1 The Contractor shall prepare and submit to the Architect a progress schedule, and shall comply with such schedule, as described in Subparagraphs 8.2.4 through 8.2.8.

### 3.11 DOCUMENTS AND SAMPLES AT THE SITE

3.11.1 The Contractor shall maintain at the site for the Owner one record copy of the Drawings, Specifications, Addenda, Change Orders and other Modifications, in good order and marked currently to record changes and selections made during construction, and in addition, approved Shop Drawings, Product Data, Samples and similar required submittals. These shall be available to the Architect and shall be delivered to the Architect for submittal to the Owner upon completion of the Work.

### 3.12 SHOP DRAWINGS, PRODUCT DATA AND SAMPLES

3.12.1 Shop Drawings are drawings, diagrams, schedules and other data specially prepared for the Work by the Contractor or a Subcontractor Sub-subcontractor, manufacturer, supplier or distributor to illustrate some portion of the Work.

3.12.2 Product Data are illustrations, standard schedules, performance charts, instructions, brochures, diagrams and other information furnished by the Contractor to illustrate materials or equipment for some portion of the work.

3.12.3 Samples are physical examples which illustrate materials, equipment or workmanship and establish standards by which the Work will be judged.

3.12.4 Shop Drawings, Product Data, Samples and similar submittals are not Contract Documents. The purpose of their submittal is to demonstrate for those portions of the Work for which submittals are required the way the Contractor proposes to conform to the information given and the design concept expressed in the Contract Documents. Review by the Architect is subject to the limitations of this Paragraph 3.12 and Paragraph 4.2.

3.12.5 The Contractor shall review, approve and submit to the Architect Shop Drawings, Product Data, Samples and similar submittals required by the Contract Documents with reasonable promptness, in accordance with the Contractor's progress schedule approved by the Architect, and in such sequence as to cause no delay in the Work or in the activities of the Owner or of separate contractors. Submittals made by the Contractor, which are not required by the Contract Documents may be returned without action.

3.12.6 The Contractor shall perform no portion of the Work requiring submittal and review of Shop Drawings, Product Data, Samples or similar submittals until the respective submittal has been reviewed by the Architect. Such Work shall be in accordance with reviewed and approved submittals.

3.12.7 By approving and submitting Shop Drawings, Product Data, Samples, and similar submittals, the Contractor thereby represents that the Contractor has determined and verified all dimensions, quantities, field dimensions, relations to existing work, coordination with work to be installed later, coordination with information on previously accepted Shop Drawings, Product Data, Samples, or similar submittals and verification of compliance with all the requirements of the Contract Documents. The accuracy of all such information is the responsibility of the Contractor. In reviewing Shop Drawings, Product Data, Samples, and similar submittals the Architect shall be entitled to rely upon the Contractor's representation that such information is correct and accurate.

3.12.8 The Contractor shall not be relieved of responsibility for deviations from requirements of the Contract Documents by the Architect's review of Shop Drawings, Product Data, Samples or similar submittals unless the Contractor has specifically informed the Architect in writing of such deviation at the time of submittal and the Architect has given written approval to the specific deviation. The Contractor shall not be relieved of responsibility for errors or omissions in Shop Drawings, Product Data, Samples or similar submittals by the Architect's review thereof.

3.12.9 The Contractor shall direct specific attention, in writing or on resubmitted Shop Drawings, Product Data, Samples or similar submittals, to revisions other than those requested by the Architect on previous submittals. Unless such notice has been given, the Architect's review of a resubmitted Shop Drawing, Product Data, Sample, or similar submittal shall not constitute acceptance of any changes not requested on the prior submittal.

3.12.10 Informational submittals upon which the Architect is not expected to take responsible action may be so identified in the Contract Documents.

3.12.11 When professional certification of performance criteria of materials, systems or equipment is required by the Contract Documents, the Owner shall be entitled to rely upon such certifications, and neither the Owner nor the Architect shall be expected to make any independent examination with respect thereto.

3.12.12 The Architect will not check dimensions or quantities on any Shop Drawings and will not assume any responsibility for any errors in dimensions or quantities on Shop Drawings.

### 3.13 USE OF SITE.

3.13.1 The right of possession of the premises and the improvements made thereon by the Contractor shall remain at all times in the Owner. The Contractor's right to entry and use thereof arises solely from the permission granted by the Owner under the Contract Documents. The Contractor shall confine the Contractor's apparatus, the storage of materials and the

operations of the Contractor's workers to limits indicated by law, ordinances, the Contract Documents and permits and/or directions of the Architect, and shall not unreasonably encumber the premises with the Contractor's materials. The Owner shall not be liable to the Contractor, the Subcontractors, their employees or anyone else with respect to the conditions of the premises, except only for a condition caused directly and solely by the negligence of the Owner.

### 3.14 CUTTING AND PATCHING

3.14.1 The Contractor and its Subcontractors shall be responsible for cutting, fitting or patching required to complete the Work or to make its parts fit together properly, all to be performed in accordance with the requirements of the Contract Documents.

3.14.2 The Contractor shall not damage or endanger a portion of the Work or fully or partially completed construction of the Owner or separate contractors by cutting, patching or otherwise altering such construction, or by excavation. The Contractor shall not cut or otherwise alter such construction by the Owner or a separate contractor except with written consent of the Owner and of such separate contractor; such consent shall not be unreasonably withheld. The Contractor shall not unreasonably withhold from the Owner or a separate contractor the Contractor's consent to cutting or otherwise altering the Work.

### 3.15 CLEANING UP

3.15.1 The Contractor daily shall keep the premises and surrounding area free from accumulation of waste materials or rubbish caused by operations under the Contract. At completion of the Work the Contractor shall remove from and about the Project waste materials, rubbish, the Contractor's tools, construction equipment, machinery and surplus materials. Immediately prior to the Architect's inspection for Substantial Completion, the Contractor shall completely clean the premises. Concrete and ceramic surfaces shall be cleaned and washed. Resilient coverings shall be cleaned, waxed and buffed. Woodwork shall be dusted and cleaned. Sash, fixtures and equipment shall be thoroughly cleaned. Stains, spots, dust, marks and smears shall be removed from all surfaces. Hardware and all metal surfaces shall be cleaned and polished. Glass and plastic surfaces shall be thoroughly cleaned by professional window cleaners. All damaged, broken or scratched glass or plastic shall be replaced by the Contractor at the Contractor's expense.

3.15.2 If the Contractor fails to clean up as provided in the Contract Documents, the Owner may do so and the cost thereof shall be charged to the Contractor.

3.15.3 The provisions of paragraphs 3.15.1 and 3.15.2 shall apply equally to all subcontractors at the project insofar as each subcontractor's work is concerned.

### 3.16 ACCESS TO WORK

3.16.1 The Contractor shall provide the Owner and Architect access to the work in preparation and progress wherever located.

### 3.17

#### ROYALTIES AND PATENTS

3.17.1 The Contractor shall pay all royalties and license fees. The Contractor shall defend suits or claims for infringement of patent rights and shall hold the Owner and Architect harmless from loss on account thereof, but shall not be responsible for such defense or loss when a particular design, process or product of a particular manufacturer or manufacturers is required by the Contract Documents. However, if the Contractor has reason to believe that the required design, process or product is an infringement of a patent, the Contractor shall be responsible for such loss unless such information is promptly furnished to the Architect.

### 3.18

#### INDEMNIFICATION

3.18.1 To the fullest extent permitted by law, the Contractor shall indemnify and hold harmless the Owner, Architect, Architect's consultants, and agents and employees of any of them from and against claims, damages, losses and expense, including but not limited to attorneys' fees, arising out of or resulting from performance of the Work, provided that such claim, damage, loss or expense is attributable to bodily injury, sickness, disease or death, or to injury to or destruction of tangible property (other than the Work itself) including loss of use resulting therefrom, caused in whole or in part by negligent acts or omissions of the Contractor, a Subcontractor, anyone directly or indirectly employed by them or anyone for whose acts they may be liable, regardless of whether or not such claim, damage, loss or expense is caused in part by a party indemnified hereunder. Such obligation shall not be construed to negate, abridge or reduce other rights or obligations of indemnity which would otherwise exist as to a party or person described in this Paragraph 3.18.

3.18.2 In claims against any person or entity indemnified under this Paragraph 3.18 by an employee of the Contractor, a Subcontractor, anyone directly or indirectly employed by them or anyone for whose acts they may be liable, the indemnification obligation under this Paragraph 3.18 shall not be limited by a limitation on the amount or type of damages, compensation, or benefits payable by or for the Contractor or a Subcontractor under workers' or workmen's compensation acts, disability benefit acts, or other employee benefit acts.

3.18.3 The obligations of the Contractor under this Paragraph 3.18 shall not extend to the liability of the Architect, the Architect's consultants and agents and employees of any of them arising out of (1) the preparation of maps, Drawings, opinions, reports, surveys, Change Orders, designs or Specifications, or (2) directions or instructions given by the Architect, the Architect's consultants, and agents or employees of any of them.

### 3.19

#### COVENANT NOT TO SUE

3.19.1 In consideration of the Contractor's undertaking to indemnify and hold harmless the Architect, the Architect's consultants and agents or employees of any of them, in accordance with Paragraph 3.18, agree that the Architect will not bring any civil suit, action or other proceeding in law, equity or arbitration against the Contractor, or the officers, employees, agents and servants of the Contractor, for or on account of any action which the Architect may have arising out of or in any manner connected with the Work, except to enforce the provisions of



Paragraph 3.18 and this Paragraph 3.19; and the Contractor, or any successor, assign or subrogee of the Contractor, agrees not to bring any civil suit, action or other proceeding in law, equity or arbitration against the Architect, or the officers, employees, agents and servants of the Architect, for the enforcement of any action which the Contractor may have arising out of or in any manner connected with the Work.

### 3.20 RECORD KEEPING REQUIREMENTS

3.20.1 The Contractor shall comply with all applicable requirements of Mass. Gen. Laws Chapter 30, Section 39R.

## ARTICLE 4

### ADMINISTRATION OF THE CONTRACT

#### 4.1 ARCHITECT

4.1.1 The Architect is the person lawfully licensed to practice architecture or an entity lawfully practicing architecture identified as such in the Agreement and is referred to throughout the Contract Documents as if singular in number. The term "Architect" means the Architect or the Architect's authorized representative.

4.1.2 Duties, responsibilities and limitations of authority of the Architect as set forth in the Contract Documents shall not be restricted, modified or extended without written consent of the Owner, Contractor and Architect. Consent shall not be unreasonably withheld. To the extent inconsistent herewith, the rights and responsibilities of the Architect shall be governed by the Owner/Architect Agreement for the Project.

4.1.3 In case of termination of employment of the Architect, the Owner shall appoint an architect whose status under the Contract Documents shall be that of the former architect.

#### 4.2 ARCHITECT'S ADMINISTRATION OF THE CONTRACT

4.2.1 The Architect will provide administration of the Contract as described in the Contract Documents. The Architect will advise and consult with the Owner. The Architect will have authority to act on behalf of the Owner only to the extent provided in the Contract Documents, unless otherwise modified by written instrument in accordance with other provisions of the Contract.

4.2.2 The Architect will visit the site at intervals appropriate to the stage of construction to become generally familiar with the progress and quality of the completed Work and to determine in general if the Work is being performed in a manner indicating that the Work, when completed, will be in accordance with the Contract Documents. The Architect will visit the site at least once per week during periods of active construction. The Architect will not be required to make exhaustive or continuous on-site inspections to check quality or quantity of the Work. On the basis of on-site observations as an architect, the Architect will keep the Owner informed

of progress of the Work, and will endeavor to guard the Owner against defects and deficiencies in the Work.

4.2.3 The Architect will not have control over or charge of and will not be responsible for construction means, methods, techniques, sequences or procedures, or for safety precautions and programs in connection with the Work, since these are solely the Contractor's responsibility as provided in Paragraph 3.3. The Architect will not be responsible for the Contractor's failure to carry out the Work in accordance with the Contract Documents. The Architect will not be responsible for acts or omissions of the Contractor, Subcontractors, or their agents or employees, or of any other persons performing portions of the Work.

4.2.4 Communications Facilitating Contract Administration. Except as otherwise provided in the Contract Documents or when direct communications have been specially authorized, the Owner and Contractor shall endeavor to communicate through the Project Manager. Communications by and with the Architect's consultants shall be through the Architect. Communications by and with Subcontractors and material suppliers generally shall be through the Contractor, although the Owner and Project Manager may have direct communications with subcontractors and suppliers intended to facilitate or expedite construction. Communications by and with separate contractors shall be through the Owner.

As to any written communications between two of the three of the Owner, Architect, and Contractor, a concurrent copy shall be sent to the third.

4.2.5 The Architect will have authority to reject Work which does not conform to the Contract Documents. Whenever the Architect considers it necessary or advisable for implementation of the intent of the Contract Documents, the Architect will have authority to require additional inspection or testing of the Work in accordance with Subparagraphs 13.5.2 and 13.5.3, whether or not such Work is fabricated, installed or completed. However, neither this authority of the Architect nor a decision made in good faith either to exercise or not to exercise such authority shall give rise to a duty or responsibility of the Architect to the Contractor, Subcontractors, material and equipment suppliers, their agents or employees, or other persons performing portions of the Work.

4.2.6 In accordance with generally accepted standards of professional practice the Architect will review, approve, and take other appropriate action upon the Contractor's submittals such as Shop Drawings, Product Data and Samples, for the purpose of checking for conformance with the Contract Documents. The Architect's action will be taken with reasonable promptness, while allowing sufficient time in the Architect's professional judgment to permit adequate review, and in any event shall take no longer than the time permitted by law. Review of such submittals is not conducted for the purpose of determining the accuracy and completeness of other details such as dimensions and quantities, or for substantiating instructions for installation or performance of equipment or systems, all of which remain the responsibility of the Contractor as required by the Contract Documents. The Architect's review of the Contractor's submittals shall not relieve the Contractor of obligations set forth in Paragraphs 3.3, 3.5 and 3.12. The Architect's review shall not constitute approval of safety precautions or, unless otherwise specifically stated by the Architect, of any construction means, methods,

techniques, sequences or procedures. The Architect's action with respect to any specific item shall not indicate approval of an assembly of which the item is a component.

4.2.7 The Architect will prepare Change Orders and Construction Change Directives, and may authorize minor changes in the Work as provided in Paragraph 7.4.

4.2.8 The Architect will conduct inspections to determine the date or dates of Substantial Completion and the date of final completion, will receive and forward to the Owner for the Owner's review and records written warranties and related documents required by the Contract and assembled by the Contractor, and will issue a final Certificate for Payment upon compliance with the requirements of the Contract Documents.

4.2.9 If the Owner and Architect agree in writing, the Architect will provide one or more project representatives to assist in carrying out the Architect's responsibilities at the site. The duties, responsibilities and limitations of authority of such project representatives shall be as set forth in an exhibit to be incorporated in the Contract Documents. If no such exhibit has been so incorporated, the duties, responsibilities, and limitations of authority of such project representatives shall be as set forth in the edition of AIA Document B352 current as of the date of the Agreement.

4.2.10 The Architect will interpret and decide matters concerning performance under and requirements of the Contract Documents on written request of either the Owner or Contractor. The Architect's response to such requests will be made with reasonable promptness and within any time limits agreed upon. The Architect may, as the Architect judges desirable, issue additional drawings or instructions indicating in greater detail the construction or design of the various parts of the Work; such drawings or instructions may be effected by field order or other notice to the Contractor, and provided such drawings or instructions are reasonably consistent with the previously existing Contract Documents, the Work shall be executed in accordance with such additional drawings or instructions without additional cost or extension of the Contract Time. If the Contractor claims additional cost or time on account of such additional drawings or instructions, the Contractor shall give the notice provided in Subparagraph 4.3.7.

4.2.11 Interpretations and decisions of the Architect will be consistent with the intent of and reasonably inferable from the Contract Documents and will be in writing or in the form of drawings. When making such interpretations and decisions, the Architect will endeavor to secure faithful performance by the Owner and Contractor, will not show partiality to either and will not be liable for results of interpretations or decisions so rendered in good faith.

4.2.12 The Architect's decisions on matters relating to aesthetic effect will be final if consistent with the intent expressed in the Contract Documents.

#### 4.3 CLAIMS AND DISPUTES

4.3.1 Definition. A Claim is a demand or assertion by one of the parties seeking, as a matter of right, adjustment or interpretation of Contract terms, payment of money, extension of time or other relief with respect to the terms of the Contract. The term "Claim" includes Change

Order requests by the Contractor as well as other disputes and matters in question between the Owner and Contractor arising out of or relating to the Contract. Claims must be made by written notice. The responsibility to substantiate Claims shall rest with the party making the Claim.

4.3.2 Decision of Architect. Claims arising prior to final payment or the earlier termination of the Contract shall be referred initially to the Architect for action as provided in Paragraph 4.4. Action by the Architect, as provided in Paragraph 4.4, shall be required as a condition precedent to arbitration of a Claim between the Contractor and Owner as to all such matters arising prior to the date final payment is due. Action by the Architect in response to a Claim shall not be a condition precedent to arbitration in the event (1) the position of Architect is vacant; (2) the Architect has failed to take action as required under Subparagraph 4.4.1 within 15 days after the Claim is made; (3) the Architect has failed to take action required under Subparagraph 4.4.4 within 30 days after the Claim is made, unless the Architect has notified the parties in writing of the reasons why action could not be taken within 30 days, and of the date by which action will be taken; or (4) the Claim relates to a mechanic's lien.

4.3.3 Time Limits on Claim. Claims by either party must be made within 35 days after occurrence of the event giving rise to such Claim or within 35 days after the claimant first recognizes the condition giving rise to the Claim, whichever is later. Claims must be made by written notice. Any change or addition to a previously made Claim shall be made by timely written notice in accordance with this Subparagraph 4.3.3.

4.3.4 Continuing Contract Performance. Pending final resolution of a Claim including arbitration, unless otherwise agreed in writing the Contractor shall proceed diligently with performance of the Contract and the Owner shall continue to make payments in accordance with the Contract Documents.

4.3.5 Waiver of Claims: Final Payment. The making of final payment shall constitute a waiver of Claims by the Owner except those arising from:

1. liens, Claims, security interests or encumbrances arising out of the Contract and unsettled;
2. failure of the Work to comply with the requirements of the Contract Documents; or
3. terms of special warranties required by the Contract Documents.

Any Claim which has not been waived in accordance with this Subparagraph shall be deemed to have accrued upon discovery by the Owner of the condition or breach upon which such Claim is based, for the purpose of any applicable statute of limitation.

4.3.6 Claims for Differing Subsurface or Latent Physical Conditions. If, during the progress of the Work, the Contractor or the Owner discovers that the actual subsurface or latent physical conditions encountered at the site differ substantially or materially from those shown on the plans or indicated in the Contract Documents, either the Contractor or the Owner may request

an equitable adjustment in the Contract Sum applying to Work affected by the differing site conditions. A request for such an adjustment shall be in writing and shall be delivered by the party making such claim to the other party as soon as possible after such conditions are discovered. Upon receipt of such a claim from a Contractor, or upon its own initiative, the Owner shall make an investigation of such physical conditions, and, if they differ substantially or materially from those shown on the plans or indicated in the Contract Documents or from those ordinarily encountered and generally recognized as inherent in Work of the character provided for in the plans and Contract Documents and are of such a nature as to cause an increase or decrease in the cost of performance of the Work or a change in the construction methods required for the performance of the Work which results in an increase or decrease in the cost of the Work, the Owner shall make an equitable adjustment in the Contract Sum and the Contract shall be modified in writing accordingly.

4.3.6.1 Should conditions encountered below the surface of the ground require that footings, foundations or other parts of the building or other structure be raised, lowered or changed, or if additional depth of excavation below the levels shown on the Drawings is required in order to provide proper bearing for the building or other structure or for any permanent utilities on the site or for permanent grading or other permanent site work, any change in the amount of excavation, dewatering, sheeting, protection, rock excavation, backfill, concrete or other structural work, or any other work permanently incorporated in the building shall be considered a change in the Work, and the Contract Sum shall be adjusted as provided in this Article, provided that the Work has been ordered in writing as provided in 7.1.1.

4.3.7 Claims for Additional Cost or Time. If the Contractor claims that any acts or omissions of the Owner or the Architect, including any instructions or orders, whether oral, written, by Drawings, or otherwise, involve extra cost or time, and the Contractor has not received a written acknowledgment by the Owner or Architect that extra payment will be made or time extended on account thereof, the Contractor shall promptly so notify the Architect in writing of such Claim and shall not proceed with the Work relating to such Claim until the Contractor has received a further written order to proceed except, as provided in Paragraph 10.3, in the case of an emergency affecting life or property. No Claim by the Contractor on account of such acts, omissions, instructions or orders shall be valid unless the Contractor has so notified the Architect before proceeding, and has received the further written order to proceed.

4.3.7.1 OMITTED.

4.3.7.2 - The Contractor shall have the burden of demonstrating the effect of the claimed act or omission on the Contract Sum or Contract Time, and shall furnish the Architect with such documentation relating thereto as the Architect may reasonably require. In the case of a continuing act or omission only one Claim is necessary.

4.3.7.3 Adverse weather conditions shall not be the basis for a Claim for additional time or cost.

4.3.8 Injury or Damage to Person or Property. If either party to the Contract suffers injury or damage to person or property because of an act or omission of the other party, of any of

the other party's employees or agents, or of others for whose acts such party is legally liable, written notice of such injury or damage, whether or not insured, shall be given to the other party within a reasonable time not exceeding 21 days after first observance. The notice shall provide sufficient detail to enable the other party to investigate the matter. If a Claim for additional cost or time related to this Claim is to be asserted, it shall be filed as provided in Subparagraph 4.3.7.

#### 4.4 REVIEW OF CLAIMS BY ARCHITECT

4.4.1 The Architect shall take one or more of the following actions within ten days of receipt of a Claim: (1) defer any action with respect to all or any part of a Claim and request additional information from either party; (2) decline to render a decision for any reason which he deems appropriate, (including but not limited to the fact that the Claim involves allegations of fault on the part of the Architect); (3) render a decision on all or a part of the Claim, or (4) submit a schedule to the parties indicating when the Architect expects to take action. The Architect shall notify the parties in writing of any action taken with respect to such Claim. If the Architect renders a decision or declines to render a decision, either party may proceed in accordance with Paragraph 4.5. If the Architect decides that the Work relating to such Claim should proceed regardless of his disposition of such Claim, the Architect shall issue to the Contractor a written order to proceed. The Contractor shall proceed as instructed, and all rights of both parties with respect to such Claim shall be deemed to have been reserved.

4.4.2 If a Claim is resolved by agreement of the parties, the Architect will prepare or obtain appropriate documentation indicating the parties' agreement to the resolution. In the absence thereof, the Claim shall be treated as not resolved.

4.4.3 If a Claim has not been resolved, the party making the Claim shall, within ten days after the Architect's request, take one or more of the following actions: (1) submit additional supporting data requested by the Architect; (2) modify the initial Claim; (3) respond to the Architect's action under paragraph 4.4.1; or (4) notify the Architect that the initial Claim stands. Upon receipt of the response or supporting data, the Architect will either reject or approve the claim in whole or in part.

#### 4.5 ARBITRATION

4.5.1 **Controversies and Claims Subject to Arbitration.** Any Claim arising out of or related to the Contract, or the breach thereof, except claims relating to aesthetic effect, shall be settled by arbitration, subject to the foregoing provisions of paragraph 4.4 and the provisions of Subparagraph 4.5.7. Arbitration will be conducted in accordance with the Construction Industry Arbitration Rules of the American Arbitration Association and judgment upon the award rendered by the Arbitrator or Arbitrators may be entered in any Court having jurisdiction thereof. In any such arbitration in which the amount stated in the demand is \$100,000 or less, a single arbitrator shall be appointed in accordance with the procedures set forth in the American Arbitration Association Construction Industry Arbitration Rules. In any such arbitration in which the amount stated in the demand is in excess of \$100,000, a panel of three arbitrators shall be appointed in accordance with the procedures set forth in the American Arbitration Association Construction Industry Arbitration Rules.

4.5.2- Rules For Arbitration. The parties may agree to any arbitration forum. If unable to agree, by default the forum shall be the American Arbitration Association. If the neutral arbitrator(s) is/are appointed by the American Arbitration Association, the said Association shall administer the arbitration and its Construction Industry Arbitration Rules shall govern all aspects of the proceeding including the enforcement of any award. If the neutral arbitrator(s) is/are not appointed by the American Arbitration Association, then the arbitrator(s) shall act as the administrator of the arbitration but the Construction Industry Arbitration Rules of the Association shall nonetheless govern all aspects of the proceeding, including the enforcement of any award. The arbitration panel shall have all of the powers and duties conferred on the Association pursuant to said rules.

In addition, the following rules shall govern the selection of arbitrators and the proceedings:

4.5.2.1 Neither party may appoint as arbitrator an employee or an owner of that party, nor the parent, spouse or child of an employee or owner of that party.

4.5.2.2 After the neutral arbitrator has been appointed, neither party may engage in ex parte communication with the arbitrator appointed by that party.

4.5.3 Contract Performance During Arbitration. During arbitration proceedings, the Owner and Contractor shall comply with Subparagraph 4.3.4.

4.5.4 When a written decision of the Architect states that the decision is final, any demand for arbitration of the matter covered by such decision must be made within two months after substantial completion of the project, as determined by the Architect in accordance with paragraph 9.8.2 hereof. The failure to demand arbitration within said two month period will result in the Architect's decision becoming final and binding upon the Owner and the Contractor.

4.5.4.1 A demand for arbitration shall be made within the time limits specified in Subparagraph 4.5.4, and in no event shall be made after the date when the institution of legal or equitable proceedings based on such Claim would be barred by the applicable statute of limitations.

4.5.5 Claims and Timely Assertion of Claims. A party who files a notice of demand for arbitration must assert in the demand all Claims then known to that party on which arbitration is permitted to be demanded. When a party fails to include a Claim through oversight, inadvertence or excusable neglect, or when a Claim has matured or been acquired subsequently, the arbitrator or arbitrators may permit amendment.

4.5.6 Judgment on Final Award. The award rendered by the arbitrator or arbitrators shall be final, and judgment may be entered upon it in accordance with applicable law in any court having jurisdiction thereof.

4.5.7 Notwithstanding any provision contained in this Paragraph 4.5 or elsewhere in the Contract Documents, the Owner reserves the following rights in connection with Claims and disputes between the Owner and the Contractor:

1. the right to institute legal action against the Contractor in any court of competent jurisdiction in lieu of demanding arbitration pursuant to this Paragraph 4.5, in which case the dispute or disputes which are the subject of such action shall be decided by such court, and not by arbitration;
2. the right to obtain from any court of competent jurisdiction a stay of any arbitration instituted by the Contractor, provided that the application for such stay is made before the appointment of the neutral arbitrator in such arbitration, in which case the dispute or disputes which are the subject of such arbitration shall be decided by such court, and not by arbitration;
3. the right to require the Contractor to join as a party in any arbitration between the Owner and the Architect relating to the Project, in which case the Contractor agrees to be bound by the decision of the arbitrator or arbitrators in such arbitration.

In case the Owner elects to proceed in accordance with 4.5.7.1 or 4.5.7.2 above, the word "litigation" shall be deemed to replace the word "arbitration" wherever the latter word appears in the Contract Documents.

## ARTICLE 5

### SUBCONTRACTORS

#### 5.1 DEFINITIONS

5.1.1 A Subcontractor is a person or entity who has a direct contract with the Contractor to perform a portion of the Work at the site. The term "Subcontractor" is referred to throughout the Contract Documents as if singular in number and means a Subcontractor or an authorized representative of the Subcontractor. The term "Subcontractor" does not include a separate contractor or Subcontractors of a separate contractor.

5.1.2 A Sub-subcontractor is a person or entity who has a direct or indirect contract with a Subcontractor to perform a portion of the Work at the site. The term "Sub-subcontractor" is referred to throughout the Contract Documents as if singular in number and means a Sub-subcontractor or an authorized representative of the Sub-subcontractor.

#### 5.2 AWARD OF SUBCONTRACTS AND OTHER CONTRACTS FOR PORTIONS OF THE WORK

5.2.1 Unless otherwise stated in the Contract Documents or the bidding requirements, the Contractor, as soon as practicable after award of the Contract, shall furnish in writing to the



Owner through the Architect the names of persons or entities (including those who are to furnish materials or equipment fabricated to a special design) proposed for each principal portion of the Work. The Architect will promptly reply to the Contractor in writing stating whether or not the Owner or the Architect, after due investigation, has reasonable objection to any such proposed person or entity. Failure of the Owner or Architect to reply promptly shall constitute notice of no reasonable objection.

5.2.2 The Contractor shall not contract with a proposed person or entity to whom the Owner or Architect has made reasonable and timely objection. The Contractor shall not be required to contract with anyone to whom the Contractor has made reasonable objection, unless otherwise required by law to do so.

5.2.3 If the Owner or Architect has reasonable objection to a person or entity proposed by the Contractor, the Contractor shall propose another to whom the Owner or Architect has no reasonable objection. The Contract Sum shall be increased or decreased by the difference in cost occasioned by such change and an appropriate Change Order shall be issued. However, no increase in the Contract Sum shall be allowed for such change unless the Contractor has acted promptly and responsively in submitting names as required.

5.2.4 The Contractor shall not change a Subcontractor, person or entity previously selected if the Owner or Architect makes reasonable objection to such change.

5.2.5 The form of each filed Subcontract shall be submitted to the Owner for its acceptance, which shall not be unreasonably withheld or delayed. The form of subcontract shall be that set forth in Mass. Gen. Laws Chapter 149, Section 44F. Each Subcontract shall expressly provide for the contingent assignment referred to in Paragraph 5.4.

### 5.3 SUBCONTRACTUAL RELATIONS

5.3.1 By appropriate agreement, written where legally required for validity, the Contractor shall require each Subcontractor, to the extent of the Work to be performed by the Subcontractor, to be bound to the Contractor by terms of the Contract Documents, and to assume toward the Contractor all the obligations and responsibilities which the Contractor, by these Contract Documents, assumes toward the Owner and Architect, including without limitation the obligations set forth in Paragraph 3.18. Each Subcontract agreement shall preserve and protect the rights of the Owner and Architect under the Contract Documents with respect to the Work to be performed by the Subcontractor so that Subcontracting thereof will not prejudice such rights, and shall allow to the Subcontractor, unless specifically provided otherwise in the Subcontract agreement, the benefit of all rights, remedies and redress against the Contractor that the Contractor, by the Contract Documents, has against the Owner. Where appropriate, the Contractor shall require each Subcontractor to enter into similar agreements with Sub-subcontractors. The Contractor shall make available to each proposed Subcontractor, prior to the execution of the Subcontract agreement, copies of the Contract Documents to which the Subcontractor will be bound, and, upon written request of the Subcontractor, identify to the Subcontractor terms and conditions of the proposed Subcontract agreement which may be at

variance with the Contract Documents. Subcontractors shall similarly make copies of applicable portions of such documents available to their respective proposed Sub-subcontractors.

#### 5.4 CONTINGENT ASSIGNMENT OF SUBCONTRACTS

5.4.1 Each Subcontract agreement for a portion of the Work is assigned by the Contractor to the Owner provided that:

1. assignment is effective only after termination of the Contract by the Owner for cause pursuant to Paragraph 14.2 and only for those Subcontract agreements which the Owner accepts by notifying the Subcontractor in writing; and
2. assignment is subject to the prior rights of the surety, if any, obligated under bond relating to the Contract.

### ARTICLE 6

#### CONSTRUCTION BY OWNER OR BY SEPARATE CONTRACTS

#### 6.1 OWNER'S RIGHT TO PERFORM CONSTRUCTION AND TO AWARD SEPARATE CONTRACTS

6.1.1 The Owner reserves the right to perform construction or operations related to the Project with the Owner's own forces, and to award separate contracts in connection with other portions of the Project or other construction or operations on the site under Conditions of the Contract identical or substantially similar to these, including those portions related to insurance and waiver of subrogation. If the Contractor claims that delay or additional cost is involved because of such action by the Owner, the Contractor shall make such Claim as provided elsewhere in the Contract Documents.

6.1.2 When separate contracts are awarded for different portions of the Project or other construction or operations on the site, the term "Contractor" in the Contract Documents in each case shall mean the Contractor who executes each separate Owner-Contractor Agreement.

6.1.3 The Owner shall provide for coordination of the activities of the Owner's own forces and of each separate contractor with the work of the Contractor, who shall cooperate with them. The Contractor shall participate with other separate contractors and the Owner in reviewing their progress schedules when directed to do so. The Contractor shall make any revisions to the progress schedules and Contract Sum deemed necessary after a joint review and mutual agreement. The progress schedules shall then constitute the schedules to be used by the Contractor, separate contractors and the Owner until subsequently revised.

## 6.2 MUTUAL RESPONSIBILITY

6.2.1 The Contractor shall afford the Owner and separate contractors reasonable opportunity for introduction and storage of their materials and equipment and performance of their activities and shall connect and coordinate the Contractor's construction and operations with theirs as required by the Contract Documents.

6.2.2 If part of the Contractor's Work depends for proper execution or results upon construction or operations by the Owner or a separate contractor, the Contractor shall, prior to proceeding with that portion of the Work, promptly report to the Architect apparent discrepancies or defects in such other construction that would render it unsuitable for such proper execution and results. Failure of the Contractor so to report shall constitute an acknowledgement that the Owner's or separate contractors' completed or partially completed construction is fit and proper to receive the Contractor's Work, except as to defects not then reasonably discoverable.

6.2.3 Costs caused by delays or by improperly timed activities or defective construction shall be borne by the party responsible therefor.

6.2.4 The Contractor shall promptly remedy damage wrongfully caused by the Contractor to completed or partially completed construction or to property of the Owner or separate contractors as provided in Subparagraph 10.2.5. If such separate contractor sues or initiates an arbitration proceeding against the Owner on account of any damage alleged to have been caused by the Contractor, the Owner shall notify the Contractor, who shall defend such proceedings at the Contractor's expense, and if any judgment or award against the Owner arises therefrom the Contractor shall pay or satisfy it and shall reimburse the Owner for all attorneys' fees and court or arbitration costs which the Owner has incurred.

6.2.5 Claims and other disputes and matters in question between the Contractor and a separate contractor shall be subject to the provisions of Paragraph 4.3 provided the separate contractor has reciprocal obligations.

6.2.6 The Owner and each separate contractor shall have the same responsibilities for cutting and patching as are described for the Contractor in Paragraph 3.14.

## 6.3 OWNER'S RIGHT TO CLEAN UP

6.3.1 If a dispute arises among the Contractor, separate contractors and the Owner as to the responsibility under their respective contracts for maintaining the premises and surrounding area free from waste materials and rubbish as described in Paragraph 3.15, the Owner may clean up and allocate the cost among those responsible as the Architect determines to be just.

## ARTICLE 7

### CHANGES IN THE WORK

#### 7.1 CHANGES

7.1.1 Changes in the Work may be accomplished after execution of the Contract, and without invalidating the Contract, by Change Order, Construction Change Directive or order for a minor change in the Work, subject to the limitations stated in this Article 7 and elsewhere in the Contract Documents.

7.1.2 A Change Order shall be based upon agreement among the Owner, Contractor and Architect; a Construction Change Directive requires agreement by the Owner and Architect and may or may not be agreed to by the Contractor; an order for a minor change in the Work may be issued by the Architect alone.

7.1.3 Changes in the Work shall be performed under applicable provisions of the Contract Documents, and the Contractor shall proceed promptly, unless otherwise provided in the Change Order, Construction Change Directive or order for a minor change in the Work.

7.1.4 If unit prices are stated in the Contract Documents or subsequently agreed upon, and if quantities originally contemplated are so changed in a proposed Change Order or Construction Change Directive that application of such unit prices to quantities of Work proposed will cause substantial inequity to the Owner or Contractor, the applicable unit prices shall be equitably adjusted.

#### 7.2 CHANGE ORDERS

7.2.1 A Change Order is a written instrument prepared by the Architect and signed by the Owner, Contractor and Architect, stating their agreement upon all of the following:

- 1 a change in the Work;
- 2 the amount of the adjustment in the Contract Sum, if any; and
- 3 the extent of the adjustment in the Contract Time, if any.

#### 7.3 CONSTRUCTION CHANGE DIRECTIVES

7.3.1 A Construction Change Directive is a written order prepared by the Architect and signed by the Owner and Architect, directing a change in the Work and stating a proposed basis for adjustment, if any, in the Contract Sum or Contract Time, or both. The Owner may by Construction Change Directive, without invalidating the Contract, order changes in the Work within the general scope of the Contract consisting of additions, deletions or other revisions, the Contract Sum and Contract Time being adjusted accordingly.

7.3.2 A Construction Change Directive shall be used in the absence of total agreement on the terms of a Change Order.

7.3.3 Upon request of the Owner or the Architect, the Contractor shall without cost to the Owner submit to the Architect, in such form as the Architect may require, an accurate written estimate of the cost of any proposed extra Work or change contemplated by a Construction Change Directive. The estimate shall indicate the quantity and unit cost of each item of materials, and the number of hours of work and hourly rate for each class of labor, as well as the description and amounts of all other costs chargeable under the terms of this Article. Unit labor costs for the installation of each item of materials shall be shown if required by the Architect. The Contractor shall promptly revise and resubmit such estimate if the Architect determines that it is not in compliance with the requirements of this Article, or that it contains errors of fact or mathematical errors. If required by the Architect, in order to establish the exact cost of new Work added or of previously required Work omitted, the Contractor shall obtain and furnish to the Architect bona fide proposals from recognized suppliers for furnishing any material included in such Work. Such estimates shall be furnished promptly so as to occasion no delay in the Work, and shall be furnished at the Contractor's expense. The Contractor shall state in the estimate any extension of time required for the completion of the Work if the change or extra work is ordered.

7.3.3.1 If the Construction Change Directive provides for an adjustment to the Contract Sum, the adjustment shall be based on one of the following methods, as selected by the Owner:

- (a) By unit prices stated in the Contract Documents or otherwise mutually agreed upon.
- (b) By Cost and Percentages (as defined below) estimated by the Contractor as provided in Subparagraph 7.3.3 and accepted by the Owner; the Contractor's estimate shall become a fixed price which shall not be changed by any variation in the actual cost of executing the Work covered by the change.
- (c) By actual Cost determined after the Work covered by the change is completed, plus Percentage.
- (d) By use of the dispute resolution procedures set forth in Paragraph 4.3.

As used in this Paragraph 7.3, "Cost" shall mean the estimated or actual net increase or decrease in cost to the Contractor, Subcontractor, or Sub-subcontractor for performing the Work covered by the change, including actual payments for materials, equipment, rentals, expendable items, wages and associated benefits to workmen and to supervisors employed full time at the site, insurance, bonds and other provable direct costs, but not including any administrative, accounting or expediting costs, or other indirect or overhead costs, or any wages or benefits of supervisory personnel not assigned full time to the site, or any amount for profit or fee to the Contractor, Subcontractor or Sub-subcontractor.

"Percentage" shall mean an allowance to be added to or subtracted from the Cost in lieu of overhead and profit and of any other expense which is not included in the Cost of the Work

covered by the change, as defined above. Percentage for a Sub-subcontractor shall be 10% of any net increase or decrease of Cost of any Work performed by the Sub-subcontractor's own forces plus 5% of any aggregate net increase in Cost of any Work performed for the Sub-subcontractor by other contractors. Percentage for a Subcontractor shall be such percentage allowances for overhead and profit as are set forth in the Subcontract between such Subcontractor and the Contractor. Percentage for the Contractor shall be 9 1/2% of any net increase or decrease of Cost of any Work performed by the Contractor's own forces plus 4 1/2% of any net increase or decrease in the Cost for all other Work covered by the change.

When in the reasonable judgment of the Architect a series of Construction Change Directives or Change Orders effect a single change, Percentage shall be calculated on the cumulative net increase or decrease in Cost, if any.

7.3.3.2. If the Owner elects to determine the cost of the Work as provided in method (a) of sub-Subparagraph 7.3.3.1, the unit prices shall be subject to Subparagraph 7.1.4. Notwithstanding the inclusion of unit prices in the Contract Documents, it shall be the Owner's option to require the Cost of any given change to be determined by one of the other methods stated in 7.3.3.1. If the Owner elects to determine the Cost of the change by unit prices and the nature of the work is such that its extent cannot readily be measured after the completion of such work or any subsequent work, the Contractor shall keep daily records, available at all times to the Architect for inspection, of the actual quantities of such work put in place, and delivery receipts or other adequate evidence, acceptable to the Architect, indicating the quantities of materials delivered to the site for use in such unit price work, and distinguishing such other similar material delivered for use in work included in the base Contract Sum. If so required by the Architect, materials for use in unit price work shall be stored apart from all other materials on the Project.

7.3.3.3. If the Owner elects to determine the cost of the Work as provided in methods (c) or (d) of sub-Subparagraph 7.3.3.1 or if the method of determining the cost has not been established before the Work is begun, the Contractor shall keep detailed daily records of labor and materials costs applicable to the Work.

7.3.4. Upon receipt of a Construction Change Directive, the Contractor shall promptly proceed with the change in the Work involved and advise the Architect of the Contractor's agreement or disagreement with the method, if any, provided in the Construction Change Directive for determining the proposed adjustment in the Contract Sum or Contract Time.

7.3.5. A Construction Change Directive signed by the Contractor indicates the agreement of the Contractor therewith, including adjustment in Contract Sum and Contract Time or the method for determining them. Such agreement shall be effective immediately and shall be recorded as a Change Order.

7.3.6. If the Owner and Contractor do not agree with the adjustment in Contract Sum or Contract Time or the method for determining the adjustment, the dispute shall be governed by the procedures set forth in Paragraph 4.3.

#### 7.4 MINOR CHANGES IN THE WORK

7.4.1 The Architect will have authority to order minor changes in the Work not involving adjustment in the Contract Sum or extension of the Contract Time and not inconsistent with the intent of the Contract Documents. Such changes shall be effected by written order and shall be binding on the Owner and Contractor. The Contractor shall carry out such written orders promptly.

### ARTICLE 8

#### TIME

#### 8.1 DEFINITIONS

8.1.1 Unless otherwise provided, Contract Time is the period of time, including authorized adjustments, allotted in the Contract Documents for Substantial Completion of the Work.

8.1.2 The date of commencement of the Work is the date established in the Agreement. The date shall not be postponed by the failure to act of the Contractor or of persons or entities for whom the Contractor is responsible.

8.1.3 The date of Substantial Completion is the date certified by the Architect in accordance with Paragraph 9.8.

8.1.4 The term "day" as used in the Contract Documents shall mean calendar day, unless otherwise specifically defined.

#### 8.2 PROGRESS AND COMPLETION

8.2.1 Time limits stated in the Contract Documents are of the essence of the Contract. By executing the Agreement the Contractor confirms that the Contract Time is a reasonable period for performing the Work.

8.2.2 The Contractor shall not knowingly, except by agreement or instruction of the Owner in writing, prematurely commence operations on the site or elsewhere prior to the effective date of insurance required by Article 11 to be furnished by the Contractor. The date of commencement of the Work shall not be changed by the effective date of such insurance. Unless the date of commencement is established by a notice to proceed given by the Owner, the Contractor shall notify the Owner in writing, not less than five days or other agreed period before commencing the Work to permit the timely filing of mortgages, mechanic's liens and other security interests.

8.2.3 The Contractor shall proceed expeditiously with adequate forces and shall achieve Substantial Completion within the Contract Time.

8.2.4 Within two weeks after award of the Contract, the Contractor shall submit to the Architect a Progress Schedule showing for each class of work the percentage completion to be obtained and the total dollar value of work to be completed as of the first of each month until Substantial Completion.

8.2.5 The Progress Schedule shall be based on an orderly progression of the Work, allowing adequate time for each operation (including adequate time for submission and review of submittals), and leading to a reasonable certainty of Substantial Completion by the date established in the Agreement. The Progress Schedule will be reviewed by the Architect for compliance with the requirements of this Article and will be accepted by the Architect or returned to the Contractor for revision and resubmittal. Unless specifically required by law, no payment under this Contract shall be due until the Progress Schedule has been approved by the Architect.

8.2.6 If in any application for payment as provided for in Paragraph 9.2, the total value of the completed Work in place, as certified by the Architect, is less than 90% of the total value of the Work in place estimated in the Progress Schedule, the Owner may, at the Owner's option, require the Contractor to accelerate the progress of the Work without cost to the Owner by increasing the work force or hours of work, or by other reasonable means approved by the Architect.

8.2.7 If each of three successive applications for payment indicate that the actual Work completed, as certified by the Architect, is less than 90% of the values estimated in the Progress Schedule to be completed by the respective dates, the Owner may at the Owner's option, treat the Contractor's delinquency as a default justifying the action permitted under Paragraph 14.2.

8.2.8 If the Architect has determined that the Contractor should be permitted to extend the time for completion as provided in Paragraph 8.3, the calendar dates in the Progress Schedule shall be adjusted accordingly to retain their same relationship to the adjusted date of Substantial Completion, and the dollar value of Work to be completed as of the first of each month shall be adjusted pro rata.

8.2.9 If the Contractor fails to submit any application for payment in any month, the Architect shall, for the purpose of this evaluation of progress, certify separately to the actual value of the Work in place completed as of the first of the month and to the best of the Architect's knowledge.

8.2.10 Nothing herein shall limit the Owner's right to liquidated or other damages for delays by the Contractor or to any other remedy which the Owner may possess under other provisions of the Contract Documents or by law.

8.2.11 The Progress Schedule required hereunder shall be a CPM Schedule in accordance with the Project Specifications and shall be updated in accordance therewith.



### 8.3 DELAYS AND EXTENSION OF TIME

8.3.1 If the Contractor is delayed at any time in progress of the Work by an act or neglect of the Owner or Architect, of an employee of either, or of a separate contractor employed by the Owner, or by changes ordered in the Work, or by labor disputes, fire, unusual delay in deliveries, unavoidable casualties or other causes (except weather) beyond the Contractor's control, or by delay authorized by the Owner, or by other causes which the Architect determines may justify delay, then the Contract Time shall be extended for such reasonable time as the Architect may determine.

8.3.2 Claims relating to time shall be made in accordance with applicable provisions of Paragraph 4.3.

8.3.3 The Contractor hereby agrees that the Contractor shall have no claim for damages of any kind against the Owner or the Architect on account of any delay in the commencement of the Work and/or any delay or suspension of any portion of the Work, whether such delay is caused by the Owner, the Architect, or otherwise, except as specifically provided in Subparagraphs 2.3.2 and 2.3.3. The Contractor acknowledges that, except as provided therein, the Contractor's sole remedy for any such delay and/or suspension will be an extension of time as provided in this Article.

8.3.4 No claim for delay shall be allowed on account of failure of the Architect to furnish Drawings, Specifications or instructions or to return Shop Drawings or Samples until the expiration of the applicable time period referred to in Mass. Gen. Laws Chapter 90, Section 39P, and not then unless such claim be reasonable.

8.3.5 No extension of time shall be granted because of seasonal or abnormal variations in temperature, humidity or precipitation, which conditions shall be wholly at the risk of the Contractor, whether occurring within the time originally scheduled for completion or within the period of any extension granted. There shall be no increase in the Contract Sum on account of any additional costs of operations or conditions resulting therefrom.

## ARTICLE 9

### PAYMENTS AND COMPLETION

#### 9.1 CONTRACT SUM

9.1.1 The Contract Sum is stated in the Agreement and, including authorized adjustments, is the maximum amount payable by the Owner to the Contractor for performance of the Work under the Contract Documents, or in equity, should the Contractor assert a quantum meruit claim for the fair value of Contractor's Work, regardless of whether the Contractor is terminated hereunder.

## 9.2

## APPLICATIONS FOR PAYMENT

9.2.1 Within fifteen days after receipt from the Contractor, at the place designated by the Owner if such a place is so designated, of a periodic estimate requesting payment of the amount due for the preceding month, the Owner will make a periodic payment to the Contractor for the Work performed during the preceding month and for the materials not incorporated in the Work but delivered and suitably stored at the site (or at some location agreed upon in writing) to which the Contractor has title or to which a Subcontractor has title and has authorized the Contractor to transfer title to the Owner, less (1) retention based on the Owner's estimate of the fair value of its claims against the Contractor and less (2) a retention for direct payments to Subcontractors based on demands for same in accordance with the provisions of Subparagraph 9.6.2, and less (3) a retention not exceeding five percent of the approved amount of the periodic payment.

9.2.2 After the receipt of a periodic estimate requesting final payment and within sixty-five days after (a) the Contractor fully completes the Work or substantially completes the Work so that the value of the Work remaining to be done is, in the estimate of the Owner, less than one percent of the original Contract Sum, or (b) the Contractor substantially completes the work and the Owner takes possession for occupancy, whichever occurs first, the Owner shall pay the Contractor the entire balance due on the Contract less (1) a retention based on its estimate of the fair value of its claims against the Contractor and the cost of completing the incomplete and unsatisfactory items of Work and less (2) a retention for direct payments to Subcontractors based on demands for same in accordance with the provisions of Subparagraph 9.6.2, or based on the record of payments by the Contractor to the Subcontractors under this Contract if such record of payment indicates that the Contractor has not paid Subcontractors as provided in Subparagraph 9.6.2. If the Owner fails to make payment as herein provided, there shall be added to each such payment daily interest at the discount rate then charged by the Federal Reserve Bank of Boston, commencing on the first day after said payment is due and continuing until the payment is delivered or mailed to the Contractor; provided, that no interest shall be due, in any event, on the amount due on a periodic estimate for final payment until fifteen days after receipt of such a periodic estimate from the Contractor, at the place designated by the Owner if such a place is so designated. The Contractor agrees to pay to each Subcontractor a portion of any such interest paid in accordance with the amount due each Subcontractor.

9.2.3 The Owner may make changes in any periodic estimate submitted by the Contractor, and the payment due on said periodic estimate shall be computed in accordance with the changes so made, but such changes or any requirement for a corrected periodic estimate shall not affect the due date for the periodic payment or the date for the commencement of interest charges on the amount of the periodic payment computed in accordance with the changes made, as provided herein; provided, that the Owner may, within seven days after receipt, return to the Contractor for correction, any periodic estimate which is not in the required form or which contains computations not arithmetically correct and, in that event, the date of receipt of such periodic estimate shall be the date of receipt of the corrected periodic estimate in proper form and with arithmetically correct computations. The date of receipt of a periodic estimate received on a Saturday, Sunday, or holiday shall be the first working day thereafter.

9.2.4 All periodic estimates shall be submitted to the Owner, or to the Owner's representative, and the date of receipt by the Owner or its representative shall be marked on the estimate. All periodic estimates shall contain a separate item for each filed subtrade and each sub-subtrade listed in sub-bid form as required by the Specifications and a column listing the amount paid to each Subcontractor and Sub-subcontractor as of the date the periodic estimate is filed. The person making payment for the Owner shall add the daily interest provided for herein to each payment for each day beyond the due date based on the date of receipt marked on the estimate.

9.2.5 The format and number of copies of applications for payment shall be as directed by the Architect. Such application shall be notarized, if required, and supported by such data substantiating the Contractor's right to payment as the Owner or Architect may require, such as copies of requisitions from Subcontractors and material suppliers, and reflecting retainage if provided for elsewhere in the Contract Documents.

9.2.5.1 Such applications may include requests for payment on account of changes in the Work which have been properly authorized by Construction Change Directives but not yet included in Change Orders when such Construction Change Directives have set forth an adjustment to the Contract Sum.

9.2.5.2 Such applications may not include requests for payment of amounts the Contractor does not intend to pay to a Subcontractor or material supplier because of a dispute or other reason.

9.2.6 Unless otherwise provided in the Contract Documents, payments shall be made on account of materials and equipment delivered and suitably stored at the site for subsequent incorporation in the Work. If approved in advance by the Owner, payment may similarly be made for materials and equipment suitably stored off the site at a location agreed upon in writing. Payment for materials and equipment stored on or off the site shall be conditioned upon compliance by the Contractor with procedures satisfactory to the Owner to establish the Owner's title to such materials and equipment or otherwise protect the Owner's interest, and shall include applicable insurance, storage and transportation to the site for such materials and equipment stored off the site.

9.3 The Contractor warrants that title to all Work covered by an application for payment will pass to the Owner either by incorporation in the construction or upon receipt of payment by the Contractor, whichever occurs first, free and clear of all liens, claims, security interests, or encumbrances, hereinafter referred to in this Article 9 as "liens."

#### 9.4 CERTIFICATES FOR PAYMENT

9.4.1 The Architect will, within seven days after receipt of the Contractor's application for payment, either issue to the Owner a Certificate for Payment, with a copy to the Contractor, for such amount as the Architect determines is properly due, or notify the Contractor and Owner in writing of the Architect's reasons for withholding certification in whole or in part as provided in Subparagraph 9.5.1.

9.4.2 The issuance of a Certificate for Payment will constitute a representation by the Architect to the Owner, based on the Architect's observations at the site and the data comprising the application for payment, that the Work has progressed to the point indicated and that, to the best of the Architect's knowledge, information and belief, the quality of the Work is in accordance with the Contract Documents. The foregoing representations are subject to an evaluation of the Work for conformance with the Contract Documents upon Substantial Completion, to results of subsequent tests and inspections, to minor deviations from the Contract Documents correctable prior to completion, and to specific qualifications expressed by the Architect. The issuance of a Certificate for Payment will further constitute a representation that the Contractor is entitled to payment in the amount certified. However, the issuance of a Certificate for Payment will not be a representation that the Architect has (1) made exhaustive or continuous on-site inspections to check the quality or quantity of the Work, (2) reviewed construction means, methods, techniques, sequences or procedures, (3) reviewed copies of requisitions received from Subcontractors and material suppliers and other data requested by the Owner to substantiate the Contractor's right to payment or (4) made examination to ascertain how or for what purpose the Contractor has used money previously paid on account of the Contract Sum.

## 9.5 DECISIONS TO WITHHOLD CERTIFICATION

9.5.1 The Architect may decide not to certify payment and may withhold a Certificate for Payment in whole or in part, to the extent reasonably necessary to protect the Owner, if in the Architect's opinion the representations to the Owner required by Subparagraph 9.4.2 cannot be made. If the Architect is unable to certify payment in the amount of the Application, the Architect will notify the Contractor and Owner as provided in Subparagraph 9.4.1. If the Contractor and Architect cannot agree on a revised amount, the Architect will promptly issue a Certificate for Payment for the amount for which the Architect is able to make such representations to the Owner. The Architect may also decide not to certify payment or, because of subsequently discovered evidence or subsequent observations, may nullify the whole or a part of a Certificate for Payment previously issued, to such extent as may be necessary in the Architect's opinion to protect the Owner from loss because of:

- 1 defective Work not remedied;
- 2 third party claims filed or reasonable evidence indicating probable filing of such claims;
- 3 failure of the Contractor to make payments properly to Subcontractors or for labor, materials or equipment;
- 4 reasonable evidence that the Work cannot be completed for the unpaid balance of the Contract Sum;
- 5 damage to the Owner or another contractor;

- 6 reasonable evidence that the Work will not be completed within the Contract Time, and that the retainage currently held by the Owner would not be adequate to cover actual or liquidated damages for the anticipated delay; or
- 7 persistent failure to carry out the Work in accordance with the Contract Documents.

9.5.2 When the above reasons for withholding certification are removed, certification will be made for amounts previously withheld.

## 9.6 PROGRESS PAYMENTS

9.6.1 After the Architect has issued a Certificate for Payment, the Owner shall make payment in the manner and within the time provided in the Contract Documents, and shall so notify the Architect.

### 9.6.2 Payments to Subcontractors

9.6.2.1 Forthwith after the Contractor receives payment on account of a periodic estimate, the Contractor shall pay to each Subcontractor the amount paid for the labor performed and the materials furnished by that Subcontractor, less any amount specified in any court proceedings barring such payment and also less any amount claimed due from the Subcontractor by the Contractor.

9.6.2.2 Not later than the sixty-fifth day after each Subcontractor substantially completes his work in accordance with the plans and Specifications, the entire balance due under the Subcontract less amounts retained by the Owner as the estimated cost of completing the incomplete and unsatisfactory items of work, shall be due the Subcontractor, and the Owner shall pay that amount to the Contractor. The Contractor shall forthwith pay to the Subcontractor the full amount received from the Owner less any amount specified in any court proceedings barring such payment and also less any amount claimed due from the Subcontractor by the Contractor.

9.6.2.3 Each payment made by the Owner to the Contractor pursuant to Subparagraphs 9.6.2.1 and 9.6.2.2 of this paragraph for the labor performed and the materials furnished by a Subcontractor shall be made to the Contractor for the account of that Subcontractor, and the Owner shall take reasonable steps to compel the Contractor to make each such payment to each such Subcontractor. If the Owner has received a demand for direct payment from a Subcontractor for any amount which has already been included in a payment to the Contractor or which is to be included in a payment to the Contractor for payment to the Subcontractor as provided in Subparagraphs 9.6.2.1 and 9.6.2.2, the Owner shall act upon the demand as provided in this section.

9.6.2.4 If, within seventy days after the Subcontractor has substantially completed the Subcontract work, the Subcontractor has not received from the Contractor the balance due under the Subcontract including any amount due for extra labor and materials furnished to the

Contractor, less any amount retained by the Owner as the estimated cost of completing the incomplete and unsatisfactory items of Work, the Subcontractor may demand direct payment of that balance from the Owner. The demand shall be by a sworn statement delivered to or sent by certified mail to the Owner, and a copy shall be delivered to or sent by certified mail to the Contractor at the same time. The demand shall contain a detailed breakdown of the balance due under the Subcontract and also a statement of the status of completion of the Subcontract work. Any demand made after substantial completion of the Subcontract work shall be valid even if delivered or mailed prior to the seventieth day after the Subcontractor has substantially completed the Subcontract work. Within ten days after the Subcontractor has delivered or so mailed the demand to the Owner and delivered or so mailed a copy to the Contractor, the Contractor may reply to the demand. The reply shall be by a sworn statement delivered to or sent by certified mail to the Owner and a copy shall be delivered to or sent by certified mail to the Subcontractor at the same time. The reply shall contain a detailed breakdown of the balance due under the Subcontract including any amount due for extra labor and materials furnished to the Contractor and of the amount due for each claim made by the Contractor against the Subcontractor.

9.6.2.5 Within fifteen days after receipt of the demand by the Owner, but in no event prior to the seventieth day after substantial completion of the Subcontract work, the Owner shall make direct payment to the Subcontractor of the balance due under the Subcontract including any amount due for extra labor and materials furnished to the Contractor, less any amount (i) retained by the Owner as the estimated cost of completing the incomplete or unsatisfactory items of Work, (ii) specified in any court proceedings barring such payment, or (iii) disputed by the Contractor in the sworn reply, provided, that the Owner shall not deduct from a direct payment any amount as provided in part (iii) if the reply is not sworn to, or for which the sworn reply does not contain the detailed breakdown required by Subparagraph 9.6.2.4. The Owner shall make further direct payments to the Subcontractor forthwith after the removal of the basis for deductions from direct payments made as provided in parts (i) and (ii) of this Subparagraph.

9.6.2.6 The Owner shall forthwith deposit the amount deducted from a direct payment as provided in part (iii) of Subparagraph 9.6.2.5 in an interest-bearing joint account in the names of the Contractor and the Subcontractor in a bank in Massachusetts selected by the Owner or agreed upon by the Contractor and the Subcontractor and shall notify the Contractor and the Subcontractor of the date of the deposit and the bank receiving the deposit. The bank shall pay the amount in the account, including accrued interest, as provided in an agreement between the Contractor and the Subcontractor or as determined by decree of a court of competent jurisdiction.

9.6.2.7 All direct payments and all deductions from demands for direct payments deposited in an interest-bearing account or accounts in a bank pursuant to Subparagraph 9.6.2.6 shall be made out of amounts payable to the Contractor at the time of receipt of demand for direct payment from a Subcontractor and out of amounts which later become payable to the Contractor and in the order of receipt of such demands from Subcontractors. All direct payments shall discharge the obligation of the Owner to the Contractor to the extent of such payment.

9.6.2.8 The Owner shall deduct from payments to the Contractor amounts which, together with the deposits in interest-bearing accounts pursuant to Subparagraph 9.6.2.6, are sufficient to

satisfy all unpaid balances of demands for direct payment received from Subcontractors. All such amounts shall be earmarked for such direct payments, and the Subcontractors shall have a right in such deductions prior to any claims against such amounts by creditors of the Contractor.

9.6.2.9 If the Subcontractor does not receive payments as provided in Subparagraph 9.6.2.1 or if the Contractor does not submit a periodic estimate for the value of the labor or materials performed or furnished by the Subcontractor and the Subcontractor does not receive payment for same when due less the deductions provided for in Subparagraph 9.6.2.1, the Subcontractor may demand direct payment by following the procedure in Subparagraph 9.6.2.4 and the Contractor may file a sworn reply as provided in that same Subparagraph. A demand made after the first day of the month following that for which the Subcontractor performed or furnished the labor and materials for which the Subcontractor seeks payment shall be valid even if delivered or mailed prior to the time payment was due on a periodic estimate from the Contractor. Thereafter the Owner shall proceed as provided in Subparagraphs 9.6.2.5, 9.6.2.6, 9.6.2.7 and 9.6.2.8.

9.6.3 Neither the Owner nor Architect shall have an obligation to pay or to see to the payment of money to a Subcontractor, Sub-subcontractor or material supplier, except as provided in Subparagraph 9.6.2, or otherwise as provided by law.

9.6.4 A Certificate for Payment, a progress payment, or partial or entire use or occupancy of the Project by the Owner shall not constitute acceptance of Work not in accordance with the Contract Documents.

9.6.5 "Subcontractor" as used in Sub-paragraphs 9.6.2.1 through 9.6.2.9 shall mean a person who files a sub-bid and receives a subcontract as a result of that filed sub-bid or who is approved by the awarding authority in writing as a person performing labor on both performing labor and furnishing materials pursuant to a contract with the Contractor. "Subcontractor" as used in other provisions of the Contract Documents shall, except as otherwise expressly provided, have the meaning set forth in Subparagraph 5.1.1.

## 9.7 FAILURE OF PAYMENT

9.7.1 If the Architect does not issue a Certificate for Payment, through no fault of the Contractor, within seven days after receipt of the Contractor's application for payment, or if the Owner does not pay the Contractor within seven days after the date established in the Contract Documents the amount certified by the Architect, then the Contractor may, upon seven additional days' written notice to the Owner and Architect, stop the Work until payment of the amount owing has been received. The Contract Time shall be extended as provided in Article 7.

## 9.8 SUBSTANTIAL COMPLETION

9.8.1 Substantial Completion is the stage in the progress of the Work when the Work is sufficiently complete in accordance with the Contract Documents so the Owner can occupy or utilize the Work for its intended use and only minor items which can be corrected or completed

without any material interference with the Owner's use of the Work remain to be corrected or completed.

9.8.2 When the Contractor considers that the Work, or a portion thereof designated in the Contract Documents for separate completion, is substantially complete and the premises comply with Subparagraph 3.15.1, the Contractor shall submit to the Architect (1) a list of items to be completed or corrected, (2) all special warranties required by the Contract Documents, endorsed by the Contractor and in a form reasonably acceptable to the Architect and (3) the permits and certificates referred to in Subparagraph 13.5.4. The failure to include any items on the list mentioned in the preceding sentence does not alter the responsibility of the Contractor to complete all Work in accordance with the Contract Documents. When the Architect on the basis of an inspection determines that the Work or designated portion thereof is substantially complete and the other conditions have been met, the Architect will then prepare a Certificate of Substantial Completion which shall establish the Date of Substantial Completion, shall state the responsibilities of the Owner and the Contractor for security, maintenance, heat, utilities, damage to the Work, and insurance, and shall fix the time within which the Contractor shall complete the items listed therein. Warranties required by the Contract Documents shall commence on the date of Substantial Completion. The Certificate of Substantial Completion shall be submitted to the Owner and Contractor for their written acceptance of the responsibilities assigned to them in such Certificate.

9.8.3 Upon Substantial Completion of the Work or designated portion thereof and upon application by the Contractor and certification by the Architect, the Owner shall make payment, reflecting adjustment in retainage, if any, for such Work or portion thereof as provided in the Contract Documents.

#### 9.9 PARTIAL OCCUPANCY OR USE

9.9.1 The Owner may occupy or use any completed or partially completed portion of the Work at any stage. Such partial occupancy or use may begin whether or not the portion is substantially complete, provided that the respective responsibilities of the Owner and Contractor with respect to payments, retainage, if any, security, maintenance, heat, utilities, damage to the Work, insurance, correction of the Work, and warranties shall be established by agreement of the Owner and Contractor or, absent such agreement, shall be determined by the Architect subject to the right of either party to contest such determination as provided in Paragraph 4.5.

9.9.2 Immediately prior to such partial occupancy or use, the Owner, Contractor and Architect shall jointly inspect the area to be occupied or portion of the Work to be used in order to determine and record the condition of the Work.

9.9.3 Unless otherwise agreed upon, partial occupancy or use of a portion or portions of the Work shall not constitute acceptance of Work not complying with the requirements of the Contract Documents.



## 9.10 FINAL COMPLETION AND FINAL PAYMENT

9.10.1 Upon receipt of written notice that the Work is ready for final inspection and acceptance and upon receipt of a final application for payment, the Architect will promptly make such inspection and, when the Architect finds the Work acceptable under the Contract Documents and the Contract fully performed, the Architect will promptly issue a final Certificate for Payment stating that to the best of the Architect's knowledge, information and belief, and on the basis of the Architect's observations and inspections, the Work has been completed in accordance with terms and conditions of the Contract Documents. The Architect's final Certificate for Payment will constitute a further representation that conditions listed in Subparagraph 9.10.2 as precedent to the Contractor's being entitled to final payment have been fulfilled.

9.10.2 Neither final payment nor any remaining retained percentage shall become due until the Contractor submits to the Architect (1) an affidavit that payrolls, bills for materials and equipment, and other indebtedness connected with the Work for which the Owner or the Owner's property might be responsible or encumbered (less amounts withheld by Owner) have been paid or otherwise satisfied, (2) a certificate evidencing that insurance required by the Contract Documents to remain in force after final payment is currently in effect and will not be canceled or allowed to expire until at least 30 days' prior written notice has been given to the Owner, (3) a written statement that the Contractor knows of no substantial reason that the insurance will not be renewable to cover the period required by the Contract Documents, (4) consent of surety, if any, to final payment and (5), if required by the Owner, other data establishing payment or satisfaction of obligations, such as receipts, releases and waivers of liens, claims, security interests or encumbrances arising out of the Contract, to the extent and in such form as may be designated by the Owner. If a Subcontractor refuses to furnish a release or waiver required by the Owner, the Contractor may furnish a bond satisfactory to the Owner to indemnify the Owner against such lien. If such lien remains unsatisfied after payments are made, the Contractor shall refund to the Owner all money that the Owner may be compelled to pay in discharging such lien, including all costs and reasonable attorneys' fees.

9.10.3 If, after Substantial Completion of the Work, final completion thereof is materially delayed through no fault of the Contractor or by issuance of Change Orders affecting final completion, and the Architect so confirms, the Owner shall, upon application by the Contractor and certification by the Architect, and without terminating the Contract, make payment of the balance due for that portion of the Work fully completed and accepted. If the remaining balance for Work not fully completed or corrected is less than retainage stipulated in the Contract Documents, and if bonds have been furnished, the written consent of surety to payment of the balance due for that portion of the Work fully completed and accepted shall be submitted by the Contractor to the Architect prior to certification of such payment. Such payment shall be made under terms and conditions governing final payment, except that it shall not constitute a waiver of claims. The making of final payment shall constitute a waiver of claims by the Owner to the extent provided in Subparagraph 4.3.5.

9.10.4 Acceptance of final payment by the Contractor, a Subcontractor or material supplier shall constitute a waiver of claims by that payee except those previously made in writing

and identified by that payee as unsettled at the time of final application for payment. Such waivers shall be in addition to the waiver described in Subparagraph 4.3.5.

## ARTICLE 10

### PROTECTION OF PERSONS AND PROPERTY

#### 10.1 SAFETY PRECAUTIONS AND PROGRAMS

10.1.1 The Contractor shall be responsible for initiating, maintaining and supervising all safety precautions and programs in connection with the performance of the Contract.

#### 10.2 SAFETY OF PERSONS AND PROPERTY

10.2.1 The Contractor shall take reasonable precautions for safety of, and shall provide reasonable protection to prevent damage, injury or loss to:

- 1 employees performing the Work and other persons who may be affected thereby;
- 2 the Work and materials and equipment to be incorporated therein, whether in storage on or off the site, under care, custody or control of the Contractor or the Contractor's Subcontractors or Sub-subcontractors;
- 3 other property at the site or adjacent thereto, such as trees, shrubs, lawns, walks, pavements, roadways, structures and utilities not designated for removal, relocation or replacement in the course of construction; and
- 4 any other property of the Owner, whether or not forming part of the Work, located at the site or adjacent thereto in areas to which the Contractor has access.

10.2.2 The Contractor shall give notices and comply with applicable laws, ordinances, rules, regulations and lawful orders of public authorities bearing on safety of persons or property or their protection from damage, injury or loss.

10.2.3 The Contractor shall erect and maintain, as required by existing conditions and performance of the Contract, reasonable safeguards for safety and protection, including posting danger signs and other warnings against hazards, promulgating safety regulations and notifying owners and users of adjacent sites and utilities.

10.2.4 When use or storage of explosives or other hazardous materials or equipment of unusual methods are necessary for execution of the Work, the Contractor shall exercise utmost care and carry on such activities under supervision of properly qualified personnel.

10.2.5 The Contractor shall promptly remedy damage and loss to property referred to in Clauses 10.2.1.2, 10.2.1.3 and 10.2.1.4. If the damage or loss is due in whole or in part to the Contractor's failure to take the precautions required by this Paragraph 10.2, the Contractor shall, subject to any reimbursement to which the Contractor is entitled under the property insurance required by the Contract Documents, bear the cost.

10.2.6 The Contractor shall designate a responsible member of the Contractor's organization at the site whose duty shall be the prevention of accidents. This person shall be the Contractor's superintendent unless otherwise designated by the Contractor in writing to the Owner and Architect.

10.2.7 The Contractor shall not load or permit any part of the construction or site to be loaded so as to endanger its safety.

10.2.8 The Contractor shall provide and maintain in good operating condition suitable and adequate fire protection equipment and services, and shall comply with all reasonable recommendations regarding fire protection made by the representatives of the fire insurance company carrying insurance on the Work or by the local fire chief or fire marshal. The area within the site limits shall be kept orderly and clean, and all combustible rubbish shall be promptly removed from the site.

10.2.9 The Contractor shall at all time protect excavations, trenches, buildings and materials, from rain water, ground water, backup or leakage of sewers, drains and other piping, and from water of any other origin and shall remove promptly any accumulation of water. The Contractor shall provide and operate all pumps, piping and other equipment necessary to this end.

10.2.10 The Contractor shall remove snow and ice which might result in damage or delay.

10.2.11 During the progress of the Work and at all times prior to the date of Substantial Completion or occupancy of the Work by the Owner, whichever is earlier, the Contractor shall provide temporary heat, ventilation, and enclosure, as required by Mass. Gen. Laws Chapter 149, Section 44F(1). The permanent heating and ventilation systems may be used for these purposes when available unless otherwise provided in the Contract Documents.

### 10.3 EMERGENCIES

10.3.1 In an emergency affecting safety of persons or property, the Contractor shall act at the Contractor's discretion, to prevent threatened damage, injury or loss. Additional compensation or extension of time claimed by the Contractor on account of an emergency shall be determined as provided in Paragraph 4.3 and Article 7.

### 10.4 VANDALISM

10.4.1 The Contractor shall be responsible for protecting the work, the work site, materials, and equipment stored at the site (or incorporated in the work), other property at the

site, or other property of the Owner, against vandalism by known or unknown persons. In discharging this obligation the Contractor shall utilize security personnel, measures, procedures, and equipment or materials necessary to prevent vandalism.

10.4.2 In the event of any damage caused by vandalism to the property/materials/equipment/items referenced in the preceding Article 10.4.1, and regardless of whether the Contractor has exercised due care in avoiding same, the Contractor shall be financially responsible therefor to whatever extent said damage is not indemnified by insurance coverage available to either the Contractor or Owner. The Contractor's obligation hereunder shall include payment of damages to whatever extent insurance coverage is unavailable due to self-insurance, a deductible, or a self-insured retention.

10.4.3 Any monies owed by the Contractor to the Owner on account of damages referenced in the preceding Article 10.4.2 may be offset by the Owner against any periodic payments made under the Contract.

## ARTICLE 11

### INSURANCE AND BONDS

#### 11.1 CONTRACTOR'S LIABILITY INSURANCE

11.1.1 The Contractor shall purchase from and maintain in a company or companies lawfully authorized to do business in the jurisdiction in which the Project is located and to which the Owner has no reasonable objection such insurance as will protect the Contractor from claims set forth below which may arise out of or result from the Contractor's operations under the Contract and for which the Contractor may be legally liable, whether such operations be by the Contractor or by a Subcontractor or by anyone directly or indirectly employed by any of them, or by anyone for whose acts any of them may be liable:

1. claims under workers' or workmen's compensation, disability benefit and other similar employee benefit acts which are applicable to the Work to be performed;
2. claims for damages because of bodily injury, occupational sickness or disease, or death of the Contractor's employees;
3. claims for damages because of bodily injury, sickness or disease, or death of any person other than the Contractor's employees;
4. claims for damages insured by usual personal injury liability coverage which are sustained (1) by a person as a result of an offense directly or indirectly related to employment of such person by the Contractor, or (2) by another person;

- 5 claims for damages, other than to the Work itself, because of injury to or destruction of tangible property, including loss of use resulting therefrom;
- 6 claims for damages because of bodily injury, death of a person or property damage arising out of ownership, maintenance or use of a motor vehicle; and
- 7 claims involving contractual liability insurance applicable to the Contractor's obligations under Paragraph 3.18.

11.1.2 The insurance required by Subparagraph 11.1.1 shall include all major divisions of coverage, and shall be on a comprehensive general basis including Premises and Operations (including X-C-U), Owner's and Contractor's Protective, Products and Completed Operations, and Owned, Nonowned, and Hired Motor Vehicles. Such insurance shall be written for not less than any limits of liability required by law or those set forth in the Contract Documents, whichever is greater.

All insurance shall be written on an occurrence basis, unless the Owner approves in writing coverage on a claims-made basis. Coverages, whether written on an occurrence or claims-made basis, shall be maintained without interruption from date of commencement of the Work until date of final payment and termination of any coverage required to be maintained after final payment. The Owner shall be added as an Additional Insured on all policies, which shall constitute primary insurance for the Owner in relation to any similar or concurrent insurance independently maintained by the Owner.

11.1.3 Certificates of insurance acceptable to the Owner shall be filed with the Owner prior to commencement of the Work. These certificates and the insurance policies required by this Paragraph 11.1 shall contain a provision that coverages afforded under the policies will not be canceled or allowed to expire until at least 30 days' prior written notice has been given to the Owner. These certificates shall set forth evidence of all coverage required by 11.1.1 and 11.1.2. The form of certificate shall be AIA Document G705. The Contractor shall furnish to the Owner copies of any endorsements that are subsequently issued amending limits of coverage. If any of the foregoing insurance coverages are required to remain in force after final payment and are reasonably available, an additional certificate evidencing continuation of such coverage shall be submitted with the final application for payment as required by Subparagraph 9.10.2.

11.1.4 In addition to Statutory Workers' Compensation Coverage, the Contractor shall provide Employers Liability Coverage at the following limits of liability:

Each accident - \$500,000;

Disease - policy limit \$500,000;

Disease - each employee \$500,000.

11.1.5 The liability insurance coverage purchased by the Contractor in order to comply with Section 11.1.1 (1-7) above shall contain the following limits of liability:

\$3,000,000 - general aggregate;

\$3,000,000 - products/completed operations aggregate;

\$1,000,000 - personal injury and advertising;

\$1,000,000 - each occurrence;

\$1,000,000 - auto liability including hired and non-owned;

\$2,000,000 - umbrella.

## 11.2 OWNER'S LIABILITY INSURANCE

11.2.1 The Owner shall be responsible for purchasing and maintaining the Owner's usual liability insurance. Optionally, the Owner may purchase and maintain other insurance for self-protection against claims which may arise from operations under the Contract. The Contractor shall not be responsible for purchasing and maintaining this optional Owner's liability insurance unless specifically required by the Contract Documents.

## 11.3 PROPERTY INSURANCE BUILDERS RISK POLICY

11.3.1 Unless otherwise provided, the Owner shall purchase and maintain, in a company or companies lawfully authorized to do business in the jurisdiction in which the Project is located, property insurance in the amount of the initial Contract Sum as well as subsequent modifications thereto for the entire Work at the site on a replacement cost basis. Such property insurance shall be maintained, unless otherwise provided in the Contract Documents or otherwise agreed in writing by all persons and entities who are beneficiaries of such insurance, until final payment has been made as provided in Paragraph 9.10 or until no person or entity other than the Owner has an insurable interest in the property required by this Paragraph 11.3 to be covered, whichever is earlier. This insurance shall include interests of the Owner, the Contractor, Subcontractors and Sub-subcontractors in the Work.

11.3.1.1 Property insurance shall be on an all-risk policy form and shall insure against the perils of fire and extended coverage and physical loss or damage including, without duplication of coverage, theft, vandalism, malicious mischief, collapse, false-work, temporary buildings and debris removal including demolition occasioned by enforcement of any applicable legal requirements, and shall cover reasonable compensation for Architect's services and expenses required as a result of such insured loss. Coverage for other perils shall not be required unless otherwise provided in the Contract Documents. The form of policy for this coverage shall provide for coverage in the event of a loss up to the contemplated value of the property following completion of all Work required under the Contract.

11.3.1.2 If the Owner does not intend to purchase such property insurance required by the Contract and with all of the coverages in the amount described above, the Owner shall so inform the Contractor in writing prior to commencement of the Work. The Contractor may then effect insurance which will protect the interests of the Contractor, Subcontractors and Sub-subcontractors in the Work, and by appropriate Change Order the cost thereof shall be charged to the Owner. If the Contractor is damaged by the failure or neglect of the Owner to purchase or maintain insurance as described above, without so notifying the Contractor, then the Owner shall bear all reasonable costs properly attributable thereto.

11.3.1.3 The property insurance maintained hereunder by the Owner has a deductible of \$100,000 applicable to each/any claim thereunder. In the event of any property damage arising from any occurrence prior to the Architect's issuance of a final Certificate for Payment under Section 9.10.1, including but not limited to property damage arising from vandalism or casualty of any kind, the Contractor shall be responsible for the cost of said property damage: (a) to the extent not indemnified by the Owner's insurance policy because of said deductible; or (b) to the extent not indemnified by the Owner's insurance policy for any other reason.

11.3.1.4 Property insurance for portions of the Work stored off site and in transit shall be procured and the cost borne by the Contractor, unless otherwise provided in the Contract Documents.

11.3.2 Boiler and Machinery Insurance. The Owner shall purchase and maintain boiler and machinery insurance required by the Contract Documents or by law, which shall specifically cover such insured objects during installation and until final acceptance by the Owner; this insurance shall include interests of the Owner, Contractor, Subcontractors and Sub-subcontractors in the Work, and the Owner and Contractor shall be named insureds.

11.3.3 Loss of Use Insurance. The Owner, at the Owner's option, may purchase and maintain such insurance as will insure the Owner against loss of use of the Owner's property due to fire or other hazards, however caused. The Owner waives all rights of action against the Contractor for loss of use of the Owner's property, including consequential losses due to fire or other hazards however caused, to the extent covered and paid by insurance under this Subparagraph 11.3.3.

11.3.4 If the Contractor requests in writing that insurance for risks other than those described herein or for other special hazards be included in the property insurance policy, the Owner shall, if possible, include such insurance, and the cost thereof shall be borne by the Contractor.

11.3.5 If during the Project construction period the Owner insures properties, real or personal or both, adjoining or adjacent to the site by property insurance under policies separate from those insuring the Project, or if after final payment property insurance is to be provided on the completed Project through a policy or policies other than those insuring the Project during the construction period, the Owner shall waive all rights in accordance with the terms of Subparagraph 11.3.7 for damages caused by fire or other perils covered by this separate property

insurance. All separate policies shall provide this waiver of subrogation by endorsement or otherwise.

11.3.6 Before an exposure to loss may occur, the Owner shall file with the Contractor a copy of each policy that includes insurance coverages required by this Paragraph 11.3. Each policy shall contain all generally applicable conditions, definitions, exclusions and endorsements related to this Project. Each policy shall contain a provision that the policy will not be canceled or allowed to expire until at least 30 days' prior written notice has been given to the Contractor.

11.3.7 Waivers of Subrogation. INTENTIONALLY OMITTED.

11.3.8 A loss insured under Owner's property insurance shall be adjusted by the Owner and made payable to the Owner on its behalf and on behalf of the insureds, as their interests may appear, subject to requirements of any applicable mortgagee clause and of Subparagraph 11.3.10. The Contractor shall pay Subcontractors their just shares of insurance proceeds received by the Contractor, and by appropriate agreements, written where legally required for validity, shall require Subcontractors to make payments to their Subcontractors in similar manner.

11.3.9 If required in writing by a party in interest, the Owner shall, upon occurrence of an insured loss, give bond for proper performance of the Owner's duties all subject to the requirements, if any, of the Owner's construction and/or permanent lender. The cost of required bonds shall be charged against proceeds received by Owner. The Owner shall deposit in a separate account proceeds so received, which the Owner shall distribute in accordance with such agreement as the parties in interest may reach, or in accordance with an arbitration award in which case the procedure shall be as provided in Paragraph 4.5.

11.3.10 The Owner shall have power to adjust and settle a loss with insurers unless one of the parties in interest shall object in writing within five days after occurrence of loss to the Owner's exercise of this power; if such objection be made, arbitrators shall be chosen as provided in Paragraph 4.5. The Owner shall, in that case, make settlement with insurers in accordance with directions of such arbitrators. If distribution of insurance proceeds by arbitration is required, the arbitrators will direct such distribution.

#### 11.4 PERFORMANCE BOND AND PAYMENT BOND

11.4.1 The Contractor shall furnish bonds covering faithful performance of the Contract and payment of obligations arising thereunder as stipulated in bidding requirements or specifically required in the Contract Documents on the date of execution of the Contract. Said bonds shall satisfy the applicable statutory requirements of the place in which the Work is to be performed.

11.4.2 Upon the request of any person or entity appearing to be a potential beneficiary of bonds covering payment of obligations arising under the Contract, the Contractor shall promptly furnish a copy of the bonds or shall permit a copy to be made.



## ARTICLE 12

### UNCOVERING AND CORRECTION OF WORK

#### 12.1 UNCOVERING OF WORK

12.1.1 If a portion of the Work is covered, contrary to the Architect's request or to requirements specifically expressed in the Contract Documents, it must, if required in writing by the Architect, be uncovered for the Architect's observation and be replaced at the Contractor's expense without change in the Contract Time.

12.1.2 If a portion of the Work has been covered in accordance with the requirements specifically expressed in the contract documents, and which the Architect has not specifically requested to observe prior to its being covered, the Architect may request to see such Work and it shall be uncovered by the Contractor. If such Work is in accordance with the Contract Documents, costs of uncovering and replacement shall, by appropriate Change Order, be charged to the Owner. If such Work is not in accordance with the Contract Documents, the Contractor shall pay such costs unless the condition was caused by the Owner or a separate contractor in which event the Owner shall be responsible for payment of such costs.

#### 12.2 CORRECTION OF WORK

12.2.1 The Contractor shall promptly correct Work rejected by the Architect or failing to conform to the requirements of the Contract Documents, whether observed before or after Substantial Completion and whether or not fabricated, installed or completed. The Contractor shall bear costs of correcting such rejected work, including additional testing and inspections and compensation for the Architect's services and expenses made necessary thereby and any cost, loss, or damages to the Owner resulting from such failure or defect.

12.2.2 If, within one year after the date of Substantial Completion of the Work or designated portion thereof, or after the date for commencement of warranties established under Subparagraph 9.9.1, or by terms of an applicable special warranty required by the Contract Documents, any of the Work is found to be not in accordance with the requirements of the Contract Documents, the Contractor shall correct it promptly after receipt of written notice from the Owner to do so unless the Owner has previously given the Contractor a written acceptance of such condition. This period of one year shall be extended with respect to portions of Work first performed after Substantial Completion by the period of time between Substantial Completion and the actual performance of the Work. This obligation under this Subparagraph 12.2.2 shall survive acceptance of the Work under the Contract and termination of the Contract. The Owner shall give such notice promptly after discovery of the condition.

12.2.3 The Contractor shall remove from the site portions of the Work which are not in accordance with the requirements of the Contract Documents and are neither corrected by the Contractor nor accepted by the Owner.

12.2.4 If the Contractor fails to correct nonconforming Work within a reasonable time, the Owner may correct it in accordance with Paragraph 2.4. If the Contractor does not proceed with correction of such nonconforming Work within a reasonable time fixed by written notice from the Architect, the Owner may remove it and store the salvable materials or equipment at the Contractor's expense. If the Contractor does not pay costs of such removal and storage within ten days after written notice, the Owner may upon ten additional days' written notice sell such materials and equipment at auction or at private sale and shall account for the proceeds thereof, after deducting costs and damages that should have been borne by the Contractor, including compensation for the Architect's services and expenses made necessary thereby. If such proceeds of sale do not cover costs which the Contractor should have borne, the Contract Sum shall be reduced by the deficiency. If payments then or thereafter due the Contractor are not sufficient to cover such amount, the Contractor shall pay the difference to the Owner.

12.2.5 The Contractor shall bear the cost of correcting destroyed or damaged construction, whether completed or partially completed, of the Owner or separate contractors caused by the Contractor's correction or removal of Work which is not in accordance with the requirements of the Contract Documents.

12.2.6 Nothing contained in this Paragraph 12.2 shall be construed to establish a period of limitation with respect to other obligations which the Contractor might have under the Contract Documents. Establishment of the time period of one year as described in Subparagraph 12.2.2 relates only to the specific obligation of the Contractor to correct the Work, and has no relationship to the time within which the obligation to comply with the Contract Documents may be sought to be enforced, nor to the time within which proceedings may be commenced to establish the Contractor's liability with respect to the Contractor's obligations other than specifically to correct the Work.

### 12.3 ACCEPTANCE OF NONCONFORMING WORK

12.3.1 If the Owner prefers to accept Work which is not in accordance with the requirements of the Contract Documents, the Owner may do so instead of requiring its removal and correction, in which case the Contract Sum will be reduced as appropriate and equitable. Such adjustment shall be effected whether or not final payment has been made.

## ARTICLE 13

### MISCELLANEOUS PROVISIONS

#### 13.1 GOVERNING LAW

13.1.1 The Contract shall be governed by the law of the place where the Project is located.

## 13.2 SUCCESSORS AND ASSIGNS

13.2.1 The Owner and Contractor respectively bind themselves, their partners, successors, assigns and legal representatives to the other party hereto and to partners, successors, assigns and legal representatives of such other party in respect to covenants, agreements and obligations contained in the Contract Documents. Except as hereinafter provided, neither party to the Contract shall assign the Contract or sublet it as a whole without the written consent of the other, nor shall the Contractor assign any moneys due or to become due to him hereunder, without the previous written consent of the Owner. The Owner may assign the Contract to any institutional lender providing construction or permanent financing for the Project or to any person acquiring the Owner's interest in the Project, and the Contractor agrees to execute all consents, certificates, and other documents required by such lender or other person in connection with such assignment.

13.2.2 If the Owner conveys its interest in the Project to a third party, any rights which the Owner may have against the Contractor arising from this Agreement shall automatically transfer to such third party.

## 13.3 WRITTEN NOTICE

13.3.1 Written notice shall be deemed to have been duly served if delivered in person to the individual or a member of the firm or entity or to an officer of the corporation for which it was intended, or if delivered at or sent by registered or certified mail to the last business address known to the party giving notice.

## 13.4 RIGHTS AND REMEDIES

13.4.1 Duties and obligations imposed by the Contract Documents and rights and remedies available thereunder shall be in addition to and not a limitation of duties; obligations; rights and remedies otherwise imposed or available by law.

13.4.2 No action or failure to act by the Owner, Architect or Contractor shall constitute a waiver of a right or duty afforded them under the Contract, nor shall such action or failure to act constitute approval of or acquiescence in a breach thereunder, except as may be specifically agreed in writing.

## 13.5 TESTS AND INSPECTIONS

13.5.1 Tests, inspections and approvals of portions of the Work required by the Contract Documents or by laws, ordinances, rules, regulations or orders of public authorities having jurisdiction shall be made at an appropriate time. Unless otherwise provided, the Contractor shall make arrangements for such tests, inspections and approvals with an independent testing laboratory or entity acceptable to the Owner, or with the appropriate public authority, and shall bear all related costs of tests, inspections and approvals. The Contractor shall give the Architect timely notice of when and where tests and inspections are to be made so the Architect may

observe such procedures. The Owner shall bear costs of tests, inspections or approvals which do not become requirements until after bids are received or negotiations concluded.

13.5.2 If the Architect, Owner or public authorities having jurisdiction determine that portions of the Work require additional testing, inspection or approval not included under Subparagraph 13.5.1, the Architect will, upon written authorization from the Owner, instruct the Contractor to make arrangements for such additional testing, inspection or approval by an entity acceptable to the Owner, and the Contractor shall give timely notice to the Architect of when and where tests and inspections are to be made so the Architect may observe such procedures. The Owner shall bear such costs except as provided in Subparagraph 13.5.3.

13.5.3 If such procedures for testing, inspection or approval under Subparagraphs 13.5.1 and 13.5.2 reveal failure of the portions of the Work to comply with requirements established by the Contract Documents, the Contractor shall bear all costs made necessary by such failure including those of repeated procedures and compensation for the Architect's services and expenses.

13.5.4 The Contractor shall obtain and deliver promptly to the Architect any occupancy permit and any certificates of final inspection of any part of the Contractor's work and operating permits for any mechanical apparatus, such as elevators, escalators, boilers, air compressors, etc. which may be required by law to permit full use and occupancy of the premises by the Owner. Receipt of such permits or certificates by the Architect shall be a condition precedent to Substantial Completion of the Work.

13.5.5 Tests or inspections conducted pursuant to the Contract Documents shall be made promptly to avoid unreasonable delay in the Work.

### 13.6 LIMITATION OF LIABILITY

13.6.1 The Owner shall be liable only to the extent of its interest in the Project, and no officer, director, partner, agent or employee of the Owner (or any partner of a partner or any agent or employee of a partner) shall ever be personally or individually liable with respect to this Contract or the Work. Each Subcontract shall include the foregoing limitation, which shall be effective if the Owner ever succeeds to the Contractor's rights and obligations under a Subcontract.

13.7 The Contractor shall comply with any decisions of the Arlington Redevelopment Board applicable to the Project, and with any other Laws, By-Laws, Rules, and Regulations or Ordinances within the Town of Arlington.

## ARTICLE 14

### TERMINATION OR SUSPENSION OF THE CONTRACT

#### 14.1 TERMINATION BY THE CONTRACTOR

14.1.1 The Contractor may terminate the Contract if the Work is stopped for a period of 30 days through no act or fault of the Contractor or a Subcontractor, Sub-subcontractor or their agents or employees or any other persons performing portions of the Work under contract with the Contractor, for any of the following reasons:

1. issuance of an order of a court or other public authority having jurisdiction, or
2. an act of government, such as declaration of national emergency, making material unavailable.

14.1.2 If one of the above reasons exists, the Contractor may, upon seven additional days' written notice to the Owner and Architect, terminate the Contract and recover from the Owner payment for Work executed and for proven loss with respect to materials, equipment, tools, and construction equipment and machinery, including reasonable overhead, profit and damages.

14.1.3 If the Work is stopped for a period of 60 days through no act or fault of the Contractor or a Subcontractor or their agents or employees or any other persons performing portions of the Work under contract with the Contractor because the Owner has persistently failed to fulfill the Owner's obligations under the Contract Documents with respect to matters important to the progress of the Work, the Contractor may, upon seven additional days' written notice to the Owner and the Architect, terminate the Contract and recover from the Owner as provided in Subparagraph 14.1.2.

#### 14.2 TERMINATION BY THE OWNER

14.2.1 If the Contractor is adjudged a bankrupt, or if the Contractor makes a general assignment for the benefit of the Contractor's creditors, or if a receiver is appointed on account of the Contractor's insolvency, or if the Contractor persistently or repeatedly refuses or fails, except in cases for which extension of time is provided, to supply enough properly skilled workmen or proper materials, or if the Contractor fails to make prompt payment to Subcontractors for materials or labor, or persistently disregards laws, ordinances, rules, regulations or orders of any public authority having jurisdiction, or otherwise is guilty of a significant violation of any provision of the Contract, including the failure to perform the Work in Accordance With the Contract, then the Contractor shall be in default, and the Owner may, without prejudice to any other right or remedy, and upon seven days' written notice to the Contractor, take possession of all materials, tools, appliances, equipment, construction equipment and machinery and vehicles, offices and other facilities on the Project site, and all

materials intended for the Work, wherever stored, and may terminate the employment of the Contractor, accept assignment of any or all Subcontracts pursuant to Paragraph 5.4, and finish the Work by whatever method the Owner may deem expedient. The Owner shall be entitled to collect from the Contractor all direct, indirect, liquidated, and consequential damages suffered by the Owner on account of the Contractor's default, including without limitation additional services and expenses of the Architect made necessary thereby. The Owner shall be entitled to hold all amounts due the Contractor at the date of termination until all of the Owner's damages have been established, and to apply such amounts to such damages.

14.2.2 When the Owner terminates the Contract for one of the reasons stated in Subparagraph 14.2.1, the Contractor shall not be entitled to receive further payment until the Work is finished. Any payment to the Contractor in quantum meruit shall be capped at the amount due under this Contract, including any adjustments, regardless of whether said termination by the Owner is deemed rightful or wrongful.

14.2.3 If the unpaid balance of the Contract Sum exceeds costs of finishing the Work, including compensation for the Architect's services and expenses made necessary thereby, such excess shall be paid to the Contractor. If such costs exceed the unpaid balance, the Contractor shall pay the difference to the Owner. The amount to be paid to the Contractor or Owner, as the case may be, shall be certified by the Architect, upon application, and this obligation for payment shall survive termination of the Contract.

21545381



## SUPPLEMENTAL STATUTORY CONDITIONS

### ARTICLE I - WAGES AND EMPLOYMENT PRACTICES

- 1.1 Preference To Veterans and Citizens In Public Work; Rate of Wages. (Statutory reference: Mass. Gen. Laws Chapter 149, Section 26) This Paragraph applies to every contract or subcontract for the construction of public works by the Commonwealth or by a county, town or district, or by persons contracting or subcontracting for such works.
- 1.1.1 In the employment of mechanics and apprentices, teamsters, chauffeurs and laborers, preference shall first be given to citizens of the Commonwealth who have been residents of the Commonwealth for at least six months at the commencement of their employment, who are veterans as defined in Mass. Gen. Laws Chapter 4, Section 7, clause 43 and who are qualified to perform the work to which the employment relates, and secondly, to citizens of the Commonwealth generally who have been residents of the Commonwealth for at least six months at the commencement of their employment, and if they cannot be obtained in sufficient numbers, then to citizens of the United States, and every contract for such work shall contain a provision to this effect. Each county, town or district in the construction of public works, or persons contracting or subcontracting for such works, shall give preference to veterans and citizens who are residents of such county, town or district.
- 1.1.2 The rate per hour of the wages paid to said mechanics and apprentices, teamsters, chauffeurs and laborers in the construction of public works shall not be less than the rate or rates of wages to be determined by the Commissioner of Labor and Industries as hereinafter provided; provided, that the wages paid to laborers employed on said works shall not be less than those paid to laborers in the municipal service of the town or towns where said works are being constructed; provided, further, that where the same public work is to be constructed in two or more towns, the wages paid to laborers shall not be less than those paid to laborers in the municipal service of the town paying the highest rate; provided, further, that if, in any of the towns where the works are to be constructed, a wage rate or wage rates have been established in certain trades and occupations by collective agreements or understandings in the private construction industry between organized labor and employers, the rate or rates to be paid on said works shall not be less than the rates so established; provided, further, that in towns where no such rate or rates have been so established, the wages paid to mechanics and apprentices, teamsters, chauffeurs and laborers on public works, shall not be less than the wages paid to the employees in the same trades and occupations by private employers engaged in the construction industry. This section shall also apply to regular employees of the Commonwealth or of a county, town or district, when such employees are employed in the construction, addition to or alteration of public buildings for which special appropriations of more than one thousand



dollars are provided. Payments by employers to health and welfare plans, pension plans and supplementary unemployment benefit plans under collective bargaining agreements or understandings between organized labor and employers shall be included for the purpose of establishing minimum wage rates as herein provided.

1.2

List of Jobs; Classifications; Determination of Rate of Wages; Schedule.  
(Statutory reference; Mass. Gen. Laws Chapter 149, Section 27) This Paragraph applies to every contract or subcontract for the construction of public works by the Commonwealth, or by a county, town or district.

The Commissioner of Labor and Industries shall prepare, for the use of such public officials or public bodies whose duty it shall be to cause public works to be constructed, a list of the several jobs usually performed on various types of public works upon which mechanics and apprentices, teamsters, chauffeurs and laborers are employed. The Commissioner shall classify said jobs, and he may revise such classifications from time to time, as he may deem advisable. Prior to awarding a contract for the construction of public works, said public official or public body shall submit to the Commissioner a list of the jobs upon which mechanics and apprentices, teamsters, chauffeurs and laborers are to be employed, and shall request the Commissioner to determine the rate of wages to be paid on each job. Said rates shall apply to all persons engaged in transporting gravel or fill to the site of said public works or removing gravel or fill from such site, regardless of whether such persons are employed by a contractor or subcontractor or are independent contractors or owner-operators. The Commissioner, subject to the provisions of Paragraph 1.1 of these Supplementary Statutory Conditions, shall proceed forthwith to determine the same; and shall furnish said official or public body with a schedule of such rate or rates of wages as soon as said determination shall have been made. In advertising or calling for bids for said works, the awarding official or public body shall incorporate said schedule in the advertisement or call for bids by an appropriate reference thereto, and shall furnish a copy of said schedule without cost, to any person requesting the same. Said schedule shall be made a part of the contract for said works and shall continue to the minimum rate or rates of wages for said employees during the life of the contract. Any person engaged in the construction of said works shall cause a legible copy of said schedule to be kept posted in a conspicuous place at the site of said works during the life of the contract. The aforesaid rates of wages in the schedule of wage rates shall include payment by employers to health and welfare plans, pension plans, and supplementary unemployment benefit plans, and such payments shall be considered as payments to persons under this section performing work as herein provided. Any employer engaged in the construction of such works who does not make payments to a health and welfare plan, a pension plan and a supplementary unemployment benefit plan, where such payments are included in said rates of wages, shall pay the amount of said payments directly to each employee engaged in said construction. Note: The awarding authority does not guarantee the accuracy of any schedule of wage rates

furnished to the Contractor hereunder, and the Contractor shall be responsible for ascertaining the prevailing wages in the area where the work will be performed.

1.3

**Employment Records To Be Kept By Contractor, Subcontractor, Statement of Compliance.** (Statutory reference; Mass. Gen. Laws Chapter 149, Section 27B)  
This Paragraph applies to every contract or subcontract for the construction of public works by the Commonwealth, or by a county, town or district.

Every Contractor, Subcontractor or public body engaged in said public works to which Paragraph 1.2 of these Supplementary Statutory Conditions applies shall keep a true and accurate record of all mechanics and apprentices, teamsters, chauffeurs and laborers employed thereon, showing the name, address and occupational classification of each such employee on said works, and the hours worked by, and the wages paid to, each such employee, and shall furnish to the Commissioner of Labor and Industries, upon his request, a copy of said record, signed by the employer or his authorized agent under the penalties of perjury. Such records shall be open to inspection by any authorized representative of the Department of Labor and Industries at any reasonable time, and as often as may be necessary.

Each such Contractor, Subcontractor or public body shall preserve its payroll records for a period of three years from the date of completion of the contract.

Each such Contractor, Subcontractor or public body shall furnish to the Commissioner of Labor and Industries within fifteen days after completion of its portion of the work a statement, executed by the Contractor, Subcontractor, or public body or by any authorized officer or employee of the Contractor, Subcontractor or public body who supervises the payment of wages in the following form:

STATEMENT OF COMPLIANCE \_\_\_\_\_, 2004

I, \_\_\_\_\_ do hereby state:  
(Name of signatory party) (Title)

That I pay or supervise the payment of the persons employed by (Contractor, Subcontractor or public body) \_\_\_\_\_ on the \_\_\_\_\_ and that all mechanics (building or project) and apprentices, teamsters, chauffeurs and laborers employed on said project have been paid in accordance with wages determined under the provisions of sections twenty-six and twenty-seven of chapter one hundred and forty-nine of the General Laws.

\_\_\_\_\_  
Signature

\_\_\_\_\_  
Title

The above mentioned copies of payroll records and statements of compliance shall be available for inspection by any interested party filing a written request to the Commissioner for such inspection.

- 1.4 Wages Paid to Operators of Trucks and Other Equipment. (Statutory reference: Mass. Gen. Laws Chapter 149, Section 27F) This Paragraph applies to every contract for the construction of public works by the Commonwealth, or by a county, city, town or district.

Prescribed rates of wages, as determined by the Commissioner of Labor and Industries, shall be paid to the operators of all trucks, vehicles or equipment employed on the Project. Said rates of wages shall be requested of said Commissioner by the awarding authority and shall be furnished by the Commissioner in a schedule containing the classification of jobs, and the rate of wages to be paid for each job. Said rates of wages shall include payments for health and welfare plans, or, if no such plan is in effect between employer and employees, the amount of such payments shall be paid directly to said operators.

- 1.5 Reserve Police Officers (Statutory reference: Mass. Gen. Laws Chapter 149, Section 27B) This Paragraph 1.5 applies to every contract for the construction, alteration, maintenance, repair or demolition of, or addition to, any public works for the Commonwealth or any political subdivision thereof.

The Contractor shall pay to any reserve police officer employed by him in any city or town the prevailing rate of wage paid to regular police officers in such city or town.

- 1.6 Eight-Hour Day, etc. This Paragraph 1.6 applies only to contracts which are subject to the provisions of Mass. Gen. Laws Chapter 149, Sections 30 and 34.

No laborer, worker, mechanic, foreman or inspector working within this Commonwealth in the employ of the Contractor, Subcontractor or other person doing or contracting to do the whole or part of the work contemplated by the contract, shall be required or permitted to work more than eight hours in any one day or more than forty-eight hours in any one week, or more than six days in any one week, except in cases of emergency.

- 1.7 Lodging, etc. (Statutory reference: Mass. Gen. Laws Chapter 149, Section 25) This Paragraph applies to every contract with the Commonwealth, a county, city or town, or with a department, board, commission, or officer acting therefor, for the doing of public work.

Every employee under this contract shall lodge, board and trade where and with whom he elects, and neither the Contractor nor his agents or employees shall, either directly or indirectly, require as a condition of the employment of any

person that the employee shall lodge, board or trade at a particular place or with a particular person.

1.8 Access to Contractor's Records (Executive Order No. 195) This paragraph applies to every contract for the purchase of services or material by any agency, bureau, board, commission, institution, or department of the Commonwealth.

The Governor or his designee, the secretary of administration and finance, and the state auditor or his designee shall have the right at reasonable times and upon reasonable notice to examine the books, records, and other compilations of data of the Contractor which pertain to the performance and requirements of this contract.

1.9 Worker's Compensation Insurance (Statutory reference: Mass. Gen. Laws Chapter 149, Section 34A) This Paragraph 1.9 applies to every contract for the construction, alteration, maintenance, repair or demolition of, or addition to, any public building or other public works for the Commonwealth or any political subdivision thereof.

The Contractor shall, before commencing performance of the contract, provide by insurance for the payment of compensation and the furnishing of other benefits under Mass. Gen. Laws Chapter 152 to all persons to be employed under the contract, and the Contractor shall continue such insurance in full force and effect during the term of the contract. Sufficient proof of compliance with this Paragraph 1.9 must be furnished at the time of execution of this contract. Failure to provide and continue in force such insurance as aforesaid shall be deemed a material breach of the contract and shall operate as an immediate termination thereof. No cancellation of such insurance, whether by the insurer or by the insured, shall be valid unless written notice thereof is given by the party proposing cancellation to the other party and to the awarding authority at least fifteen days prior to the intended effective date thereof, which date shall be expressed in full notice.

## ARTICLE 2 - EQUAL EMPLOYMENT OPPORTUNITY AND AFFIRMATIVE ACTION

(Statutory reference: Mass. Gen. Laws Chapter 151B; Executive Orders No. 74, No. 116 and No. 246). The provisions of this Article 2 are intended to comply with the Commonwealth's Supplemental Equal Employment Opportunity Anti-Discrimination and Affirmative Action Program, referred to in Executive Order No. 116 and administered by the Massachusetts Commission Against Discrimination. If no specific percentage has been inserted in Subparagraph 2.2.3 below, the applicable minimum percentage provided for in such Supplemental Program shall be deemed to have been so inserted.

2.1 Definitions. For purposes of this Contract, "minority" refers to Asian-Americans, Blacks, Spanish-Surnamed Americans, North American Indians, and Cape Verdeans. "Commission" refers to the Massachusetts Commission Against Discrimination.

2.2 Non-Discrimination and Affirmative Action Requirements. During the performance of this Contract, the Contractor and all of his Subcontractors (hereinafter "Contractor"), for himself, his assignees and successors in interest, agree to comply with Subparagraphs 2.2.1 through 2.2.11.

2.2.1 In connection with the performance of Work under this Contract, the Contractor shall not discriminate against any employee or applicant for employment because of race, color, religious creed, national origin, age or sex. The aforesaid provision shall include, but not be limited to, the following: employment upgrading, demotion, or transfer; recruitment advertising; recruitment layoff; termination; rates of pay or other forms of compensation; conditions or privileges of employment; and selection for apprenticeship. The Contractor shall post hereafter in conspicuous places, available for employees and applicants for employment, notices to be provided by the Commission setting forth the provisions of the Fair Employment Practices Law of the Commonwealth.

2.2.2 In connection with the performance of Work under this Contract, the Contractor shall undertake in good faith affirmative action measures designed to eliminate any discriminatory barriers in the terms and conditions of employment on the grounds of race, color, religious creed, national origin, age or sex, and to eliminate and remedy any effects of such discrimination in the past. Such affirmative action shall entail positive and aggressive measures to ensure equal opportunity in the areas of hiring, upgrading, demotion or transfer, recruitment, layoff or termination, rate of compensation, and in-service or apprenticeship training programs. This affirmative action shall include all action required to guarantee equal employment opportunity for all persons, regardless of race, color, religious creed, national origin, age or sex. A purpose of this provision is to ensure to the fullest extent possible an adequate supply of skilled tradesmen for this and future Commonwealth public construction projects.

2.2.3 As part of his obligation of remedial action under the foregoing Subparagraph 2.2.2, the Contractor shall maintain on this project a not less than ten percent (10%) ratio of minority employee man hours to total man hours in each job category including but not limited to bricklayers, carpenters, cement masons, electricians, ironworkers, operating engineers, and those "classes of work" enumerated in Mass. Gen. Laws Chapter 149, Section 44F.

2.2.4 In the hiring of minority journeymen, apprentices, trainees and advanced trainees, the Contractor shall rely on referrals from a multi-employer affirmative action program approved by the Commission; traditional referral methods utilized by the construction industry, and referrals from agencies, not more than three in number at any one time, designated by the Liaison Committee (described in Subparagraph 2.2.5 below) or the Commission.

- 2.2.5 At the discretion of the Commission there may be established for the life of this Contract a body to be known as the Liaison Committee. The Liaison Committee shall be composed of one representative each from the agency or agencies administering this project, hereinafter called the administering agency, the Commission and such other representatives as may be designated by the Commission in conjunction with the administering agency.
- 2.2.6 The Contractor (or his agent, if any, designated by him as the on-site equal employment opportunity officer) shall recognize the Liaison Committee as an affirmative action body, and shall establish a continuing working relationship with the Liaison Committee, consulting with the Liaison Committee on all matters related to minority recruitment, referral, employment and training.
- 2.2.7 The Contractor shall prepare projected manning tables on a quarterly basis. These shall be broken down into projections, by week, of workers required in each trade. Copies shall be furnished one week in advance of the commencement of the period covered, and also when updated, to the Commission and Liaison Committee.
- 2.2.8 Records of employment referral orders, prepared by the Contractor, shall be made available to the Commission and to the Liaison Committee on request.
- 2.2.9 The Contractor shall prepare weekly reports in a form approved by the Commission of hours worked in each trade by each employee, identified as a minority or non-minority. Copies of these shall be provided at the end of each week to the Commission and to the Liaison Committee.
- If the Contractor shall use any Subcontractor on any work performed under this Contract, he shall take affirmative action to negotiate with qualified minority Subcontractors. This affirmative action shall cover both pre-bid and post-bid periods. It shall include notification to the Office of Minority Business Assistance (within the Executive Office of Communities and Development) or its designee, while bids are in preparation, of all products, work or services for which the Contractor intends to negotiate bids.
- In the employment of journeymen, apprentices, trainees and advanced trainees, the Contractor shall give preference, first, to citizens of the Commonwealth who have served in the armed forces of the United States in time of war and have been honorably discharged therefrom or released from active duty therein, and who are qualified to perform the work to which the employment relates, and, secondly, to citizens of the Commonwealth generally, and, if such cannot be obtained in sufficient numbers, then to citizens of the United States.
- A designee of the Commission and a designee of the Liaison Committee shall each have right of access to the construction site.

2.2.10 The Contractor shall maintain as a goal on this project a not less than five percent ratio of women work force to total project hours in both the general contract and each individual filed sub-bid contract.

A Labor Scheduling Table will be used as a tool for achieving a range of women work force participation for the entire project in both the general contract and each individual filed sub-bid contract. Said Labor Scheduling Table shall be in a form acceptable to the Town.

2.2.11 Before starting work, the Contractors (includes the General Contractor, for itself and its Subcontractors, as well as all filed sub-bid Contractors) will submit plans for achievement of the equal opportunity goals of the contract. All Contractors will be required to make a good faith effort to achieve these goals. The plan will indicate if the Contractors expect to achieve the requirements during the first quarter. If there are reasons why the Contractors do not expect to achieve the requirements during the first quarter year of the contract construction phase, then the Contractors shall provide a plan calculated to address, to the extent reasonably possible, these obstacles to a good faith effort to achieve such goals.

Not more than ten days following the end of each work quarter, the Contractors will report on the achievement of the goals, detailing the good faith efforts that have been made and will continue to be made and any other appropriate efforts not yet undertaken.

All reports will be signed by an officer or principal of the company who has the authority to contractually obligate the company.

2.3 The Contractor shall comply with the provisions of Executive Order No. 74, as amended by Executive Order No. 166, dated May 1, 1975, and of Mass. Gen. Laws Chapter 151B, both of which are herein incorporated by reference and made a part of this Contract.

2.4 The Contractor, in the performance of all Work, and prior to completion of the Work, will not discriminate on grounds of race, color, religious creed, national origin, age or sex in employment practices, in the selection or retention of Subcontractors, or in the procurement of materials and rentals of equipment.

2.5 In all solicitations either by competitive bidding or negotiation made by the Contractor either for work to be performed under a subcontract or for the procurement of materials or equipment, each potential Subcontractor or supplier shall be notified in writing by the Contractor of the Contractor's obligations under this Contract relative to non-discrimination and affirmative action.

2.6 The Contractor hereby certifies that he shall comply with the minority manpower ratio and specific action steps contained herein. The Contractor shall be required to obtain from each of its Subcontractors and submit to the administering agency

prior to the performance of any work under the Contract a certification by said Subcontractor, regardless of tier, that it will comply with the minority manpower ration and specific affirmative action steps contained herein. Such certification shall be provided on forms furnished by the administering agency or, in the absence thereof, on forms prescribed by the Commission.

2.7 The Contractor's certification form must be signed by all successful low bidder(s) prior to award by the administering agency.

2.8 Compliance Information, Reports and Sanctions.

2.8.1 The Contractor will provide all information and reports required by the administering agency or the Commission on instructions issued by either of them and will permit access to its facilities and books, records, accounts and other sources of information which may be determined by the Commission to affect the employment of personnel. This provision shall apply only to information pertinent to the Commonwealth's supplementary affirmative action contract requirements. Where information required is in the exclusive possession of another who fails or refuses to furnish this information, the Contractor shall so certify to the administering agency or the Commission as appropriate and shall set forth what efforts he has made to obtain the information.

2.8.2 Whenever the administering agency, the Commission or the Liaison Committee believes the Contractor or any Subcontractor may not be operating in compliance with the terms of this Paragraph 2.8, the Commission directly, or through its designated agent, shall conduct an appropriate investigation, and may confer with the parties, to determine if such Contractor is operating in compliance with the terms of this Paragraph 2.8. If the Commission or its agent finds the Contractor or any Subcontractor not in compliance, it shall make a preliminary report on non-compliance, and notify such Contractor in writing of such steps as will in the judgment of the Commission or its agent bring such Contractor into compliance. In the event that such Contractor fails or refuses to fully perform such steps, the Commission shall make a final report of non-compliance, and recommend to the administering agency the imposition of one or more of the sanctions listed below. If, however, the Commission believes the Contractor or any Subcontractor has taken or is taking every possible measure to achieve compliance, it shall not make a final report of non-compliance. Within fourteen days of the receipt of the recommendations of the Commission, the administering agency shall move to impose one or more of the following sanctions, as it may deem appropriate to attain full and effective enforcement:

- (i) The recovery by the administering agency from the Contractor of 1/100 of 1% of the contract award price or \$1,000, whichever sum is greater, in the nature of liquidated damages or, if a Subcontractor is in non-compliance, the recovery by the administering agency from the Contractor, to be assessed by the Contractor as a back charge against



the Subcontractor, of 1/10 or 1% of the subcontract price, or \$400, whichever sum is greater, in the nature of liquidated damages, for each week that such party fails or refuses to comply,

(ii) The suspension of any payment or part thereof due under the Contract until such time as the Contractor or any Subcontractor is able to demonstrate his compliance with the terms of the contract;

(iii) The termination, or cancellation, of the Contract, in whole or in part, unless the Contractor or any subcontractor is able to demonstrate within a specified time his compliance with the terms of the Contract;

(iv) The denial to the Contractor or any Subcontractor of the right to participate in any future contracts awarded by the administering agency for a period of up to three years.

If at any time after the imposition of one or more of the above sanctions a Contractor is able to demonstrate that he is in compliance with this Paragraph 2.8, he may request that the administering agency, in consultation with the Commission, suspend the sanctions conditionally, pending a final determination by the Commission as to whether the Contractor is in compliance. Upon final determination of the Commission, the administering agency, based on the recommendation of the Commission, shall either lift the sanctions or reimpose them.

Sanctions enumerated under Subparagraph 2.8.2 of this Paragraph 2.8 shall not be imposed by the administering agency except after an adjudicatory proceeding as that term is used in Mass. Gen. Laws Chapter 30A, has been conducted. No investigation by the Commission or its agent shall be initiated without prior notice to the Contractor.

2.9 Severability. The provisions of this Article 2 are severable, and if any of these provisions shall be held unconstitutional by any court of competent jurisdiction, the decision of such court shall not affect or impair any of the remaining provisions.

2.10 The Contractor shall comply with the provisions of Executive Order No. 246, relating to discrimination against and equal employment opportunity for the handicapped, which is herein incorporated by reference and made a part of this Contract. In connection with the performance of work under this Contract, the Contractor, Subcontractors and suppliers of goods and services shall not discriminate against the handicapped. Furthermore, Contractors, Subcontractors and suppliers of goods and services must give written notice of their commitments under this Paragraph 2.10 to any labor union, association or brotherhood with which they have a collective bargaining contract or other agreement, and must give such notice to handicapped contractors and to handicapped contractor

associations. A copy of such notice must be furnished to the awarding authority at the time of the signing of the contract.

2.11 Suspension of Payments.

2.11.1 If the awarding authority determines after investigation that the Contractor or any Subcontractor is not in compliance with the terms of Article 2, it may suspend any payment or portion thereof due under the Contract until the Contractor demonstrates compliance with the terms of Article 2.

2.11.2 Payment shall not be suspended if the awarding authority finds that the Contractor made his best efforts to comply with Article 2, or that some other justifiable reason exists for waiving the provisions of Article 2 in whole or in part.

2.11.3 Payment may be suspended only after the Contractor and any other interested party shall have been given the opportunity to present evidence in support of its position at an informal hearing held by the awarding authority and the awarding authority has concluded upon review of all the evidence that such penalty is justified.

2.11.4 This temporary suspension of payments by the awarding authority is separate from the sanctions set forth in Paragraph 2.8 above, which are determined by the Commission and recommended to the awarding authority.

ARTICLE 3 -- MASSACHUSETTS PUBLIC CONSTRUCTION STATUTES

3.1 To whatever extent Massachusetts statutory laws regarding public construction apply to this project, said laws specifically are incorporated herein as if re-stated herein.

ARTICLE 4 - TITLE I GENERAL GOVERNMENT, ARTICLE 16 CONSTRUCTION PROJECTS; § 1-3 OF THE TOWN OF ARLINGTON GENERAL BY-LAWS

4.1 Women Work Force Participation:

4.1.1 The contractor shall maintain as a goal on this project a not less than five percent ratio of women work force to total project hours in both the general contract and each individual filed sub-bid contract, if applicable. The preceding sentence shall be included in all construction contracts whether entered into by the Town pursuant to the provisions of M.G.L. c. 149 or M.G.L. c. 30, § 39M et. seq. provided however, that if entered into under Chapter 30 same shall not be deemed to apply where the projected bid price as determined by the Director of Public Works is not likely to exceed \$200,000.

4.1.2 A Labor Scheduling Table which will be used as a tool for achieving a range of women work force participation for the entire project in both the general contract and each individual filed sub-bid contract.

4.2 Equal Opportunity Goal Compliance.

4.2.1 Before starting work, the contractors (includes the general contractor, for itself and its subcontractors, as well as all filed sub-bid contractors, if applicable) will submit plans for achievement of the equal opportunity goals of the contract. All contractors will be required to make a good faith effort to achieve these goals. The plan will indicate if the contractors expect to achieve the requirements during the first quarter. If there are reasons why the contractors do not expect to achieve the requirements during the first quarter year of the contract construction phase, then the contractors shall provide a plan calculated to address, to the extent reasonably possible, these obstacles to a good faith effort to achieve such goals.

4.2.2 Not more than ten days following the end of each work quarter, the contractors will report on the achievement of the goals, detailing the good faith efforts that have been made, and will continue to be made and any other appropriate efforts not yet undertaken.

4.2.3 All reports will be signed by an officer or principal of the company who has the authority to contractually obligate the company.

4.3 Recruitment and Training

4.3.1 Any board, officer, committee, or other agency of the Town, which acts on behalf of the Town in making or supervising any contract, in any amount exceeding the sum of \$100,000 for the purchase of goods or services or for the construction, renovation, or repair of buildings or other improvement of real estate, may make arrangements with contractors and other interested agencies for special programs of recruitment and training in connection with the work to be performed on such contract, with the objective of promoting equal employment opportunity for members of minority groups protected by the fair employment laws of the Commonwealth and the United States. Any board, officer, committee or other Town agency may expend Town funds in carrying them out provided that appropriations specifically designed for such purposes have been voted by the Town Meeting.

TOWN OF ARLINGTON

GENERAL CONTRACT

THE TOWN OF ARLINGTON, a municipal corporation of the Commonwealth of Massachusetts, acting through its Town Manager, and

\_\_\_\_\_  
\_\_\_\_\_  
\_\_\_\_\_

(The Contractor) hereby mutually agree as follows:

ARTICLE I - THE CONTRACT DOCUMENTS

The Contract Documents, as defined in the CONSOLIDATED GENERAL CONDITIONS and SUPPLEMENTAL STATUTORY CONDITIONS, including said CONSOLIDATED GENERAL CONDITIONS and SUPPLEMENTAL STATUTORY CONDITIONS are hereby incorporated by reference and made a part hereof, and shall include Addenda and Alternates, if any.

ARTICLE II - GENERAL DESCRIPTION OF THE WORK

The Contractor shall furnish all of the materials and perform all of the Work required by the Contract Documents entitled \_\_\_\_\_ dated \_\_\_\_\_ prepared by [ \_\_\_\_\_ ], acting as, and in these Contract Documents entitled, the Architect.

ARTICLE III - COMMENCEMENT AND COMPLETION OF WORK AND LIQUIDATED DAMAGES

It is agreed that time is of the essence of this Contract.

The Contractor shall commence work only upon the execution of this Contract by the Town of Arlington by its Town Manager, the certification of the availability of the appropriation by the Town Comptroller, approval as to form by the Town Counsel, and upon issuance of a Notice to Proceed, and shall bring the Work to Substantial Completion by [DATE], and to Final Completion within 15 calendar days thereafter. Liquidated damages in the amount of [\$\_\_\_] per calendar day will be applicable after the date of Substantial Completion for which the project is not substantially complete, and for each day after the date of Final Completion for which the project is not finally complete, and otherwise in accordance with the provisions of the CONSOLIDATED GENERAL CONDITIONS and SUPPLEMENTAL STATUTORY CONDITIONS. The liquidated damages amount per calendar day is a minimum damage figure to compensate the Owner for administrative costs and loss or delay of its use of the building and site, and does not limit in any way the liability of the Contractor for damages in excess of the specified liquidated damages amount for other damages, for example, damages for breach of Contract, and added architect and consultant fees. It is expressly understood that such liquidated

damages do not constitute a penalty. All work shall be phased (if applicable) in accordance with the Contract Documents.

NOTE: NOTWITHSTANDING ANYTHING TO THE CONTRARY, THE TIME OF COMMENCEMENT SHALL ONLY BE BY WRITTEN NOTICE TO PROCEED WITH THE WORK AS DATED AND ISSUED TO THE CONTRACTOR BY THE TOWN OF ARLINGTON. NOTICE TO PROCEED MAY BE GIVEN ANYTIME AFTER THE AWARD OF THE CONTRACT, BUT NOT LATER THAN 14 DAYS AFTER THE EXECUTION OF THE CONTRACT.

ARTICLE IV - COMPENSATION TO BE PAID BY TOWN

The Town shall pay and the Contractor shall accept, as full compensation for everything furnished, done by or resulting to the Contractor in carrying out this Contract, subject to additions and deductions in the Contract Documents in the sum of:

\_\_\_\_\_

ARTICLE V - AVAILABILITY OF APPROPRIATION

This Contract is subject to an appropriation being available therefor.

This Contract is executed by the Town of Arlington and by the Contractor as of this \_\_\_\_\_ day of \_\_\_\_\_, 2004.

TOWN OF ARLINGTON

BY: \_\_\_\_\_  
Town Manager

Approved as to Availability  
of Appropriation

\_\_\_\_\_  
Town Comptroller

CONTRACTOR:

\_\_\_\_\_  
(Name)

\_\_\_\_\_  
(Address)

Approved as to Form:

BY: \_\_\_\_\_  
(Name)

\_\_\_\_\_  
Town Counsel

\_\_\_\_\_  
(Title)

(Affix Corporate Seal Here)

PAYMENT BOND

Bond No. \_\_\_\_\_

KNOW ALL MEN BY THESE PRESENT, that we \_\_\_\_\_ with a place of business at \_\_\_\_\_ as principal (the "Principal"), and \_\_\_\_\_ a corporation qualified to do business in the Commonwealth of Massachusetts, with a place of business at \_\_\_\_\_ as Surety (the "Surety"), are held and firmly bound unto Town of Arlington as Obligee (the "Obligee"), in the sum of

\_\_\_\_\_ lawful money of the United States of America, to be paid to the Obligee, for which payment, well and truly to be made, we bind ourselves, our respective heirs, executors, administrators, successors and assigns, jointly and severally, firmly by these present.

WHEREAS, the Principal has assumed and made a contract with the Obligee, bearing the date of \_\_\_\_\_ for the

NOW, THE CONDITIONS of this obligation are such that if the Principal and all subcontractors under said contract shall pay for all labor performed or furnished and for all materials used or employed in said contract and in any and all duly authorized modifications, alterations, extensions of time, changes or additions to said contract that may hereafter be made, notice to the Surety of such modifications, alterations, extensions of time, changes or additions being hereby waived, the foregoing to include any other purposes or items set out in, and to be subject to, the provisions of Massachusetts General Laws, Chapter 30, Section 39A, and Chapter 149, Section 29, as amended then this obligation shall become null and void; otherwise, it shall remain in full force and virtue.

IN WITNESS WHEREFORE, the Principal and Surety have hereto set their hands and seals this \_\_\_\_\_ day of \_\_\_\_\_, 2004.

PRINCIPAL

SURETY

\_\_\_\_\_

\_\_\_\_\_

[Name and Seal]

[Attorney-In-Fact][Seal]

[Title]

[Address]

[Phone]

Attest: \_\_\_\_\_

Attest: \_\_\_\_\_

The rate for this Bond is \_\_\_\_\_ % of the first \$ \_\_\_\_\_ and \_\_\_\_\_ % for the next \$ \_\_\_\_\_.

The total premium for this Bond is \$ \_\_\_\_\_.

END OF PAYMENT BOND