

**TOWN OF ARLINGTON MASSACHUSETTS  
INVITATION TO BID # 15-23  
RECONSTRUCTION & RELATED WORK FOR ROADWAYS/MT. PLEASANT CEMETERY**

Sealed bids are invited and will be received by the Town Manager, Town of Arlington, Massachusetts, until **10:00 A.M., Thursday, June 25, 2015** at the Office of the Purchasing Agent, Town Hall, Arlington, Massachusetts 02476, at which time and place they will be publicly opened and read.

A BID DEPOSIT IN THE FORM OF CASH, CERTIFIED CHECK, OR TREASURER'S CHECK, shall accompany every bid. The amount of such bid deposit shall be FIVE PERCENT (5%) of the value of the bid.

Specifications and proposal forms will be available at the Office of the Purchasing Agent, Town Hall, Arlington, Massachusetts. All bids must be in sealed envelopes plainly marked:

**BID ON: BID # 15-23, RECONSTRUCTION & RELATED WORK FOR ROADWAYS/  
MT. PLEASANT CEMETERY**

The conditions of employment as set forth in Sections 26 to 27D and 27F of Chapter 149 of the General Laws, as amended, shall prevail in the execution of the work under this contract.

Attention is called to the fact that minimum wage rates and health and welfare and pension fund contributions are established for this contract and are a part of the specifications.

Work under this contract shall be governed by M.G.L.Ch.30, Sec.39M.

**It is the intention of the Owner to award the Contract to the lowest qualified responsive bidder. The bidder must submit a bid on all bid items in the Contract.**

An increase or decrease in the quantity of work shall not be regarded as a sufficient ground for and increase in the unit prices.

To receive consideration, bids must be in the hands of the Purchasing Agent or his authorized representative not later than the day and hour above mentioned. For further information relative to this bid, please confer with Domenic R. Lanzillotti, Director, Purchasing Department, Town Hall, Arlington, Massachusetts, 02476.

OSHA Construction Training Required: As of July 1, 2006, under M.G.L. – Chapter 30, Section 39s, any person, submitting a bid for, or signing a contract to work on, the construction, reconstruction, alteration, remodeling or repair of any public work by the Commonwealth of Massachusetts/Town of Arlington, and estimated by the awarding Authority to cost more than \$10,000, shall certify on the Bid or Contract, under penalty of perjury, that all employees to be employed at the work will have successfully completed a course in construction safety and health approved by the United States Occupational Safety and Health Administration that is at least 10 hours in duration

Prebid Site Visit: Thursday June 18, 2015, 9:00 AM, Mt. Pleasant Cemetery Chapel, 70 Medford St., Arlington, MA.

The Town Manager reserves the right to cancel any invitation for bids, to reject in whole or in part any and all bids, when it is deemed in the best interest of the Town of Arlington to do so.

TOWN OF ARLINGTON

-----  
Adam Chapdelaine  
Town Manager

Date: June 11, 2015

## I INSTRUCTION TO BIDDERS

### 1. Receipt of Bids

The Town may consider informal any bid not prepared and submitted in accordance with the provisions hereof and may waive any informality in or reject any bids. Any bid may be withdrawn before the time for the opening of bids. Any bid received after the time and date specified shall not be considered. No bidder may withdraw his/her bid for a period of 30 days, excluding Saturdays, Sundays, and legal holidays after actual date of the opening thereof.

### 2. Preparation of Bid

Each bid shall be submitted on the forms attached to these documents. The bid forms may be removed and submitted separately from the other documents. All blank spaces for bid prices must be filled in with the unit price for the item or the lump sum for which the proposal is made. Bidders must bid on each item. All entries in the entire proposal must be made clearly, and prices written in both words and figures in the spaces provided.

Each bid must be in a sealed envelope addressed to the Office of the Purchasing Agent, 730 Massachusetts Avenue, Arlington, Massachusetts, 02476; and bearing on the outside the name of the bidder, his/her address, the name of the project for which the bid is submitted, and the notation ' **BID # 15-23 RECONSTRUCTION & RELATED WORK FOR ROADWAYS/ MT. PLEASANT CEMETERY**

### 3. Bid Security

Every bid submitted by contractors shall be accompanied by a bid deposit in the form of cash, certified check, treasurer's or cashier's check, or a bid bond issued by a responsible bank or trust company and made payable to the Town of Arlington. The amount of the bid deposit shall be 5% of the amount of the bid. All security except those of the three lowest responsible and eligible bidders will be returned within ten days, Saturdays, Sundays, and legal holidays excluded, after opening of the bid. All bid securities will be returned on the execution of the contract or if no award is made within 30 days, excluding Saturdays, Sundays, and legal holidays, after the actual date of the opening thereof, unless forfeited under the conditions herein stipulated.

In case a party to whom a contract is awarded shall fail or neglect to execute the contract and furnish the satisfactory bond in the time specified, the Town may determine the bidder has abandoned the contract and thereupon the proposal and acceptance shall be null and void, and the bid security accompanying the proposal shall be forfeited to the Town as liquidation damages for such failure or neglect and indemnify the Town for any loss which may be sustained by failure of the bidder to execute the contract and furnish the bonds as aforesaid, provided that, in case of death, disability, or other unforeseen circumstances affecting the bidder, such bid security may be returned to him/her.

After execution of the contract and acceptance of the bonds by the Town, the bid security accompanying the proposal of the successful bidder will be returned.

#### 4. Time of Completion

The bidder must agree to commence work within five (5) business days from the date of signing the contract and to fully complete the project within the time specified within the Special Provisions section of this document.

#### 5. Performance and Labor Material Bonds

A bond in the sum of 50% of the total amount of the Contract by the successful bidder and an additional bond in equal amount covering the payment for all labor and materials used in the work will be required. A surety company authorized to do business in Massachusetts and satisfactory to the Town of Arlington must provide these bonds. These bonds will be required at the execution of the contract. Attorneys-in-fact who sign contract bonds must file with each bond a certified and effectively dated copy of their power of attorney.

#### 6. Laws and Regulations

The bidder's attention is directed to the fact that all applicable State laws, Town of Arlington Bylaws, municipal ordinances, and the rules and regulations of all authorities having jurisdiction over construction of the project shall apply to the contract throughout, and they shall be deemed to be included in the contract the same as though herein written out in full.

#### 7. Withdrawal of Bids

Upon proper written request and identification, Bids may be withdrawn only as follows:

- a. At any time before the designated time for the opening of Bids.
- b. Death or serious injury of a principal.
- c. With the written approval of the Town of Arlington Office of the Purchasing Director.
- d. At any time after the expiration of the period during which withdrawal is prohibited provided the bid has not been accepted by the Town.

#### 8. Execution of Contract

The party to whom the contract is awarded shall be required to execute the contract and furnish the bonds duly executed with a satisfactory surety company within five days, excluding Saturdays, Sundays, and legal holidays, of the date of the mailing of the notice to the bidder according to the address given by him/her, that the contract is ready for execution.

#### 9. Obligation of Bidder

At the time of the opening of bids, each bidder shall be presumed to have read and to be thoroughly familiar with the contract documents. The failure or omission of any bidder to receive or examine any form, instrument, or documents shall in no way relieve any bidder from the obligation in respect to his bid.

#### 10. Omissions, Discrepancies, Interpretations and Addenda

Should a bidder find discrepancies in, or omissions from, the drawings or contract documents, or should he/she have questions as to the interpretation of the plans or contract documents he/she shall submit such in writing to the Director of Purchasing at least five (5) days before the date herein set for the opening of bids. An interpretation will be mailed by certified mail to prospective bidders at the addresses given by them on or about two (2) days before the opening of bids. Signed copies of all addenda shall be included with the bid; omission of the signed addendum shall be cause for rejection of the bid.

#### 11. Record of Address

Prospective bidders shall at the time plans and specifications are secured place on file with the Director of Purchasing their address, and are required to make any changes necessary to insure that the record is accurate, complete, and up to date.

#### 12. Massachusetts Sales and Use Tax

Materials purchased for permanent installation in the work will be exempt from the Massachusetts Sales and Use tax. Each bidder shall consider this exemption in calculating his/her bid for the work.

#### 13. State Tax Affidavit

Prospective bidders are required to certify that all state tax returns have been filed and all state taxes have been paid in order to be eligible to enter into a contract with the Town on this project. The included form is to be used for this purpose and is to be completed and returned as part of the bid and proposal.

#### 14. Minimum Wage Rates

Prevailing rates for wages for work performed under this Contract will be as predetermined by the Commissioner of Labor and Industries of the Commonwealth of Massachusetts in accordance with the provisions of Sections 26 to 27D, inclusive, of c.149 of M.G.L. A schedule of the prevailing wages is included in the Minimum Wage Rates Section.

#### 15. Sub-bids

No sub bids shall be sought in connection with this Contract.

#### 16. All bidders shall submit the following supplemental information with a fee proposal:

- a. Name, address and phone number of a minimum of three (3) references that can vouch for the performance of the bidder
- b. Proof of Liability and Worker's Compensation Insurance Coverage
- c. Completed tax attestation form
- d. Bid deposit

## **II LOCATION OF WORK**

1. Work under this contract includes all labor and materials to perform Reconstruction & Related Work for Roadways/Mt. Pleasant Cemetery.

## **III PROPOSAL**

To the Town of Arlington, Massachusetts, herein called the TOWN, acting through its Town Manager; the undersigned, as bidder, declares as follows:

- a. The only persons or parties interested in this proposal as Principals are named in this proposal;
- b. This proposal is made without collusion with any other Person, firm or corporation;
- c. He has carefully examined the requirements of the proposed work;
- d. This proposal is based solely on his own investigation and research and not in reliance upon any survey, report or representations of any employee, officer or agent of the TOWN; and the undersigned proposes and agrees that if this proposal is accepted, he will contract with the TOWN, this Contract Bid Form being part of and included in said CONTRACT, to provide all necessary supervision, labor, equipment, machinery, tools, apparatus, and other means of service necessary to complete the requirements in the CONTRACT; and that he will take in full payment thereof the following sums to wit:

Bidders must bid on each item. All entries in the Contract Bid Form must be made clearly and in ink, and prices must be written in both words and figures in the space provided. Bidders should insert computed totals in the spaces provided therein:

**SPECIFICATIONS  
RECONSTRUCTION AND RELATED WORK FOR  
ROADWAYS IN MOUNT PLEASANT CEMETERY**

**DESCRIPTION**

This section pertains to the Reconstruction and Related work required prior to the placement of Stone Seal Surface to the roadways in Mt Pleasant Cemetery. Attention is called to the fact that work under this Contract Must Be Completed by **August 1, 2015**.

**General**

All work shall meet the MassDOT Standard Specifications, Latest Edition, unless otherwise noted

**Item # 1 Excavation of Existing Bituminous Surface and Fine Grade**

This item refers to the removal of existing bituminous surface and/or sub base to sufficient depth to allow for a 2 1/2" binder course to be laid prior to the chip seal course. Work shall include removal of all bituminous material, regardless of thickness encountered, placing processed gravel to achieve a consistent, crowned sub base and to the grade as directed by the Engineer, fine grade and compact. Limits of excavation are shown on the plans.

**Measurement and Payment** Measurement shall be by the Cubic Yard, and shall include all Fine Grading and Compacting necessary. Payment shall be made at the contract unit price per Cubic Yard.

Note: Gravel shall be paid for under the Processed Gravel for Sub Base item per cubic yard.

**Item # 2 Processed Gravel for Sub Base**

This item refers to the furnishing and placement of gravel for sub base and any other areas where excavation has taken place. Gravel shall meet M1.03.1 of the Standard Specifications

**Measurement and Payment** Measurement shall be by the Cubic Yard in Place. Payment shall be at the contract unit price per Cubic Yard.

**Item # 3 Bituminous Binder Course**

This item refers to the delivery and placement and compaction of 2 1/2" binder course on all areas previously excavated to sub base. Binder shall be 3/4" Type I. Binder course shall be installed according to Section 460 of the Standard Specifications and as directed by the Engineer. Binder course shall be **machine installed in one consistent lift**.

**Measurement and Payment** Measurement shall be by the Ton in Place, verified by load slips. Payment shall be at the contract unit price per Ton.

**Item # 4 Asphalt for Leveling and Miscellaneous Work**

This item refers to the delivery, placement, and compaction of bituminous mix by hand. Mix shall be 3/8" Type I Top Course. This item covers areas where drainage work has occurred, where berm pad is required, where shimming is required, where castings have been adjusted or

installed, or any other areas prior to the placement of the chip seal course as directed by the Engineer.

**Measurement and Payment** Measurement shall be by the Ton in Place, verified by load slips. Payment shall be at the contract unit price per Ton.

#### **Item # 5 Gate Box Adjusted**

This item refers to the adjustment of water gate boxes to grade as required. Following adjustment, gate boxes shall be shimmed with 3/8" bituminous Type I Top Course to prevent movement prior to the placement of chip seal course. The bituminous shim shall be included in the adjustment of the water gate box. If directed by the Engineer, a new water gate box shall be installed, and such new water gate box shall be supplied by the Town.

**Measurement and Payment** Measurement shall be by the quantity of Gate Boxes Adjusted. Payment shall be at the contract unit price Each.

#### **Item # 6 Service Box Adjusted**

This item refers to the adjustment of water service boxes to grade as required. Following adjustment, service boxes shall be shimmed with 3/8" bituminous Type I Top Course to prevent movement prior to placement of chip seal course. The bituminous shim shall be included in the adjustment of the service box. If directed by the Engineer, a new service box shall be installed, and such new service box shall be supplied by the Town.

**Measurement and Payment** Measurement shall be by the quantity of Service Boxes Adjusted. Payment shall be at the contract unit price Each.

#### **Item # 7 Drainage Structure/Manhole Adjusted**

This item refers to the adjustment of existing catch basins and manholes as required to meet proposed finish grade. Work shall conform to Section 220 of the Standard Specifications except that if the existing structure requires work over 12" vertical from finish grade, all work over 12" vertical shall be considered rebuilding and will be covered by Item #7b. Work shall include all labor and materials necessary for the excavation, removal and resetting of existing casting, and the furnishing and installation of bituminous as directed. Bituminous shall be 2 1/2" minimum thickness, concrete shall not be placed to grade. The bituminous shall be included in the adjustment of the structure.

**Measurement and Payment** Measurement shall be by the quantity of structures adjusted. Payment shall be at the contract unit price Each.

#### **Item # 7b Drainage Structure/ Manhole Rebuilt**

This item refers to all work necessary to rebuild Drainage Structures or Manholes being adjusted that require additional work at a depth greater than 12" below finish grade. Work shall include all labor and materials necessary for the excavation and rebuilding of the existing structure.

**Measurement and Payment** Measurement shall be from the top of the remaining structure considered solid to 12" below finish grade. Payment shall be at the contract unit price per Vertical Foot.



### **Item # 8 Irrigation Box/Handhole Cover Adjusted**

This item refers to the adjustment of irrigation boxes/handhole covers to grade as required. Contractor shall take note that these boxes/handhole covers are not standard MassDOT items. Care shall be used in adjustment, any damage caused during adjustment will be the responsibility of the Contractor, and replacement, if required will be the responsibility of the Contractor. No payment shall be made by the Town for such replacement, unless it is brought to the attention of the Engineer that damage had occurred prior to adjustment. Following adjustment, boxes/handhole covers shall be shimmed with 3/8" bituminous Type I Top Course prior to placement of chip seal course. The bituminous shall be included in the adjustment of the irrigation box.

**Measurement and Payment** Measurement shall be by the quantity of boxes adjusted. Payment shall be at the contract unit price Each.

### **Item # 9 Bituminous Concrete Berm**

This Item refers to the placement of bituminous concrete berm. The bituminous concrete mixture shall be placed and compacted with a machine acceptable and approved by the Engineer. The machine shall be capable of spreading the mixture to line and grade and to the shape stipulated. The shape shall be 6" high "Cape Cod" style.

**Measurement and Payment** Measurement shall be by the Linear foot measured along the centerline installed. Payment shall be at the contract unit price per Linear Foot.

### **Item # 10 Leaching Catch Basin**

This item refers to the furnishing and placement of 48" inside diameter leaching catch basins. Leaching catch basins shall be precast, 48" high, have 5" wall thickness, no sump, and be designed for H-20 loading. Leaching catch basin shall include 8" concrete cover with 24" diameter opening offset from center to allow proper alignment of casting. Leaching catch basins shall be placed on a minimum 12" bed of crushed stone and shall have a minimum 12" envelope of crushed stone. Non woven geotextile "filter fabric" shall be placed between the 12" stone envelope and the undisturbed surrounding soil. Stone shall be crushed, angular, washed, 3/4" to 2". Geotextile "filter fabric" shall meet AASHTO M288 Class 2. See Attachment # 1 for Leaching Catch Basin sample.

Note: Crushed Stone and geotextile "filter fabric" shall be considered incidental to the installation of the Leaching Catch Basin.

**Measurement and Payment** Measurement shall be by the quantity of Leaching Catch Basins installed complete in place. Payment shall be at the contract unit price Each.

### **Item # 11 Mini Dry Well**

This item refers to the furnishing and placement of 3'-6" outside diameter mini dry wells to replace existing structures or as directed by the Engineer. Dry wells shall be precast, no sump, 3'-5" high including cover, and be designed for H-20 loading. Cover shall be integral with the walls and have 20" opening to allow for casting placement. Dry wells shall be placed on a minimum 12" bed of crushed stone and shall have a minimum 12" envelope of crushed stone. Non woven geotextile "filter fabric" shall be placed between the 12" stone envelope and the undisturbed surrounding soil. Stone shall be crushed, angular, washed, 3/4" to 2". Geotextile "filter fabric" shall meet

AASHTO M288 Class 2. Dry wells shall be connected to existing drain pipes with appropriate size PVC Schedule 40 pipe and approved connector. See Attachment #2 for Mini Dry Well sample.

Note: Removal of existing drain structure when encountered shall be considered incidental to the installation of the new dry well.

Note: Crushed stone and geotextile "filter fabric" shall be considered incidental to the installation of the Mini Dry Well.

**Measurement and Payment** Measurement shall be by the quantity of Mini Dry Wells installed complete in place. Payment shall be at the contract unit price Each.

#### **Item # 12 PVC Schedule 40 Pipe**

This item refers to the furnishing and placement of PVC Schedule 40 pipe to connect dry wells to existing drain lines. Pipe shall be of diameter matching existing drain line. Connection to existing drain pipe shall be made by "Fernco" adapter.

**Measurement and Payment** Measurement shall be by the foot of pipe installed. Payment shall be at the contract unit price per Foot.

#### **Item # 13 Frame and Grate**

This item refers to the furnishing and placement of catch basin frames and grates as directed by the Engineer. Frames shall be Municipal Standard, 4 flange, 6" high, to accept 24" square hole grate. Frames and grates shall be installed as a unit, no mismatched units shall be accepted. Placing of frames shall conform to Section 201 of the Standard Specifications, except that bituminous shall be placed at a minimum thickness of 2 ½" to finish grade, concrete shall not be placed to grade. In the event a 6" high frame cannot be used due to finish grade, a 4" high frame may be substituted. In no case shall the frame be less than 4" high. Work shall conform to Section 201 of the Standard Specifications, except that a minimum of 2 ½" bituminous shall be placed to finish grade over mortar bed. In no case shall concrete be placed to finish grade. The bituminous shall be included in the installation.

**Measurement and Payment** Measurement shall be by the quantity of Frames and Grates installed complete in place. Payment shall be at the contract unit price Each.

#### **Item # 14 Structure Abandoned**

This item refers to the abandonment of an existing manhole. Work shall include removal of existing frame and cover, removal of top section of manhole, removal of walls of manhole to floor, furnishing, placing, and compaction of backfill to 12" below finish grade. Backfill shall be 3" minus gravel borrow free from loam and clay, surface coatings, and deleterious materials. Gravel shall meet M1.03.0 Type b of the Standard Specifications for Gravel Borrow. Backfill shall be placed and compacted in maximum 12" lifts. From 12" below grade to finish grade, Processed Gravel for sub base shall be used.

**Measurement and Payment** Measurement shall be by the quantity of structures abandoned complete and shall include 3" minus backfill. Payment shall be at the contract unit price Each.

**Item # 15 Loam**

This item refers to the furnishing and placement of loam in areas where existing topsoil has been disturbed or removed, areas adjacent to any excavations, behind bituminous berm, or other areas as directed by the Engineer. Placing of loam shall conform to Section 751 of the Standard Specifications. Loam shall meet M1.05.0 of the Standard Specifications.

**Measurement and Payment** Measurement shall be by the cubic yard placed. Payment shall be at the contract unit price per Cubic Yard.

**Item # 16 Seed**

This item refers to the furnishing and placement of grass seed in areas where loam has been placed. Seeding shall conform to Section 765 of the Standard Specifications. Seed shall meet M6.03.0 for Grassplots and Islands of the Standard Specifications.

**Measurement and Payment** Measurement shall be by the square yard of seed complete in place. Payment shall be at the contract unit price per Square Yard.

**Special Conditions**

This Contract involves work in Mount Pleasant Cemetery, Arlington, Massachusetts. Attention is called to the fact that Mount Pleasant is an active Cemetery. All work shall be coordinated and scheduled with the Cemetery Supervisor. There may be times when work may need to be temporarily suspended or shifted to a different section due to interments. The Cemetery Supervisor shall have the authority to suspend or shift operations. No extra compensation will be allowed for any delays resulting from Cemetery operations.

All equipment and materials shall be stored in approved areas. Approved areas shall be determined by the Cemetery Supervisor. At no time shall any equipment or materials be stored or placed on any graves. All excavated materials shall be loaded directly on trucks for removal, including excavations for catch basins, drywells, etc. All areas shall be promptly swept and left in a condition to the satisfaction of the Cemetery Supervisor at the end of every workday. All roadways shall be open for safe travel by the end of every workday.

Construction signs, barrels, and cones as required shall be supplied, installed, and removed by the contractor.

Attention is called to the fact that the Cemetery is divided into two sections, separated by a bridge. At no time shall any heavy equipment or trucks cross this bridge. There are entrances to both sections for access, and work shall be coordinated relative to this condition.

Police Detail, if required, shall be scheduled by the Contractor and paid by the Town. If Police Detail is scheduled and work is cancelled due to weather or any other reason, it shall be the

Contractor's responsibility to cancel the Police Detail at a minimum of one hour prior to scheduled start time. Failure to do so will result in the Contractor paying the Detail.

Due to some of the excavation work being less than 100' from Mill Brook, the Contractor shall be responsible for supplying, installing, maintaining, and removing erosion control. All work within the 100' boundary requiring excavation that remains unpaved overnight shall have erosion control wattles placed to either side of the excavated areas and they shall remain in place until the excavation is paved. Wattles shall be 12" diameter. Sufficient wattles shall be on site prior to the start of excavation. Wattles shall be removed immediately following paving. Wattles not reused shall be disposed of by the Contractor. No extra payment will be allowed for erosion control.

### **Instructions to Bidders**

Bidders shall enter Unit Price in numbers in Unit Price Column.

Bidder shall multiply Unit Price and Quantity, and enter amount in Total Column

Bidder shall add all Totals in Total Column, and enter amount in Bid Total Box

Contract shall be awarded to lowest Bid Total

Note: Bidders shall enter values for all Items. Items left blank may result in rejection of bid.



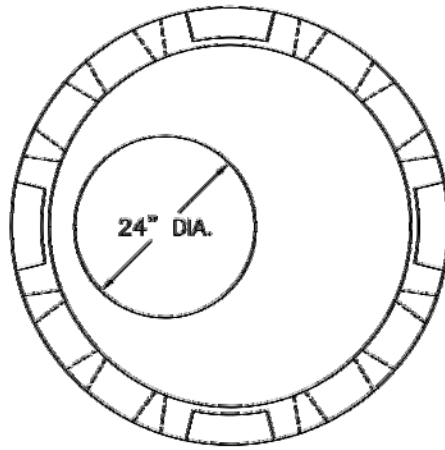

PLAN VIEW

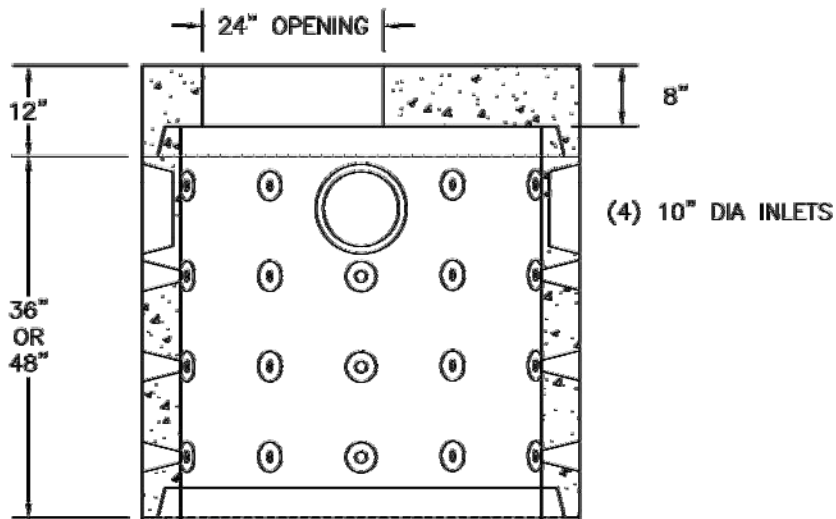

SECTION VIEW

**NOTES:**

1. CONCRETE: 4,000 PSI MINIMUM AFTER 28 DAYS.
2. DESIGNED FOR H-20 LOADING.
3. OPTIONAL ECCENTRIC CONES AVAILABLE.
4. VOLUME: 94 GALLONS/VF

**TYPICAL LEACHING  
CATCH BASIN**  
ATTACHMENT 1



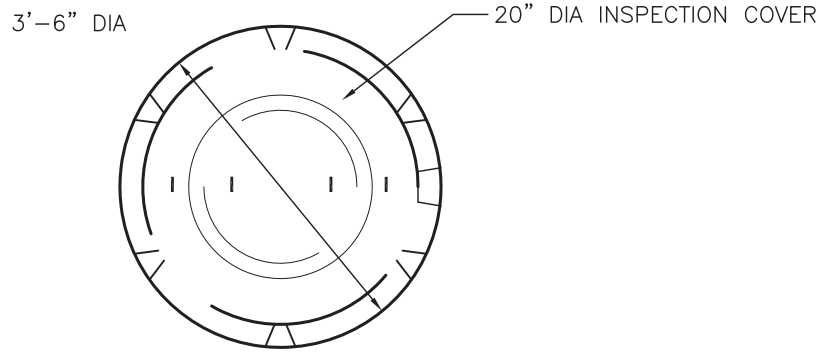

PLAN VIEW

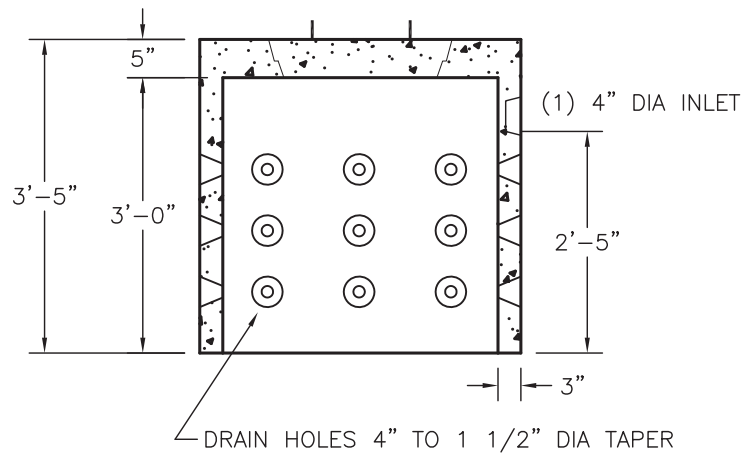

SECTION VIEW

NOTES:

1. CONCRETE: 4,000 PSI MINIMUM AFTER 28 DAYS.
2. CAPACITY INCREASES IN INCREMENTS OF 160 GALLONS FOR EVERY 3' SECTION ADDED.
3. BOTTOM PLATES AVAILABLE.

# TYPICAL MINI DRYWELL

ATTACHMENT 2

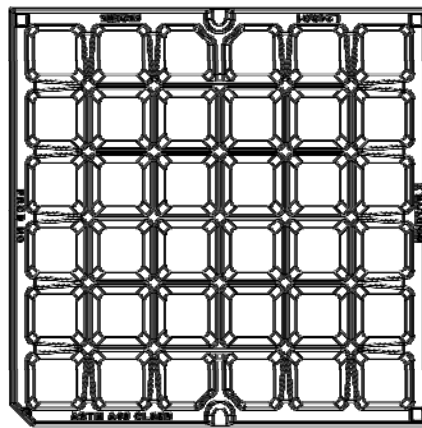
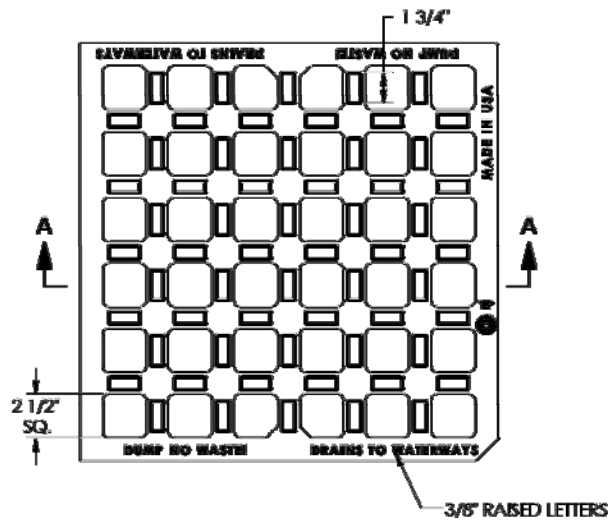

**BOTTOM VIEW**

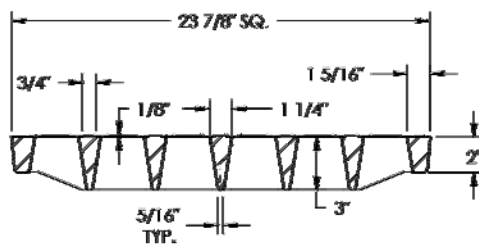

**SECTION A-A**

**Product Number**

80552860

**Design Features**

- Materials  
Gray Iron (CL358)
- Design Load  
Heavy Duty
- Open Area  
217 sq in
- Coating  
Undipped
- √ Designates Machined Surface
- Weight  
170 Lbs

**Certification**

- ASTM A48
- ASHFD H20-44
- H20 Load Rated
- Country of Origin: USA

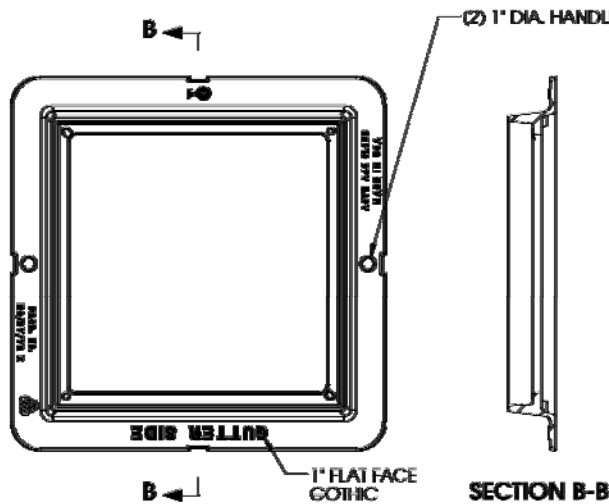

**SECTION B-B**

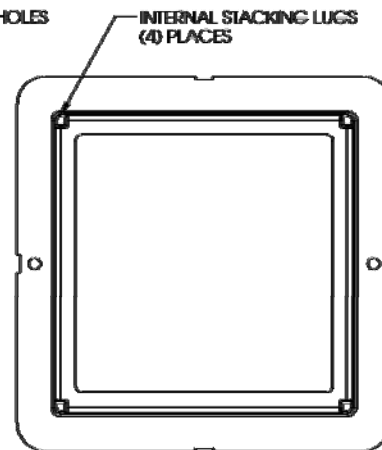

**BOTTOM VIEW**

**Product Number**

08554411

**Design Features**

- Materials  
Gray Iron (CL358)
- Design Load  
H20 Loading
- Open Area  
n/a
- Coating  
Undipped
- √ Designates Machined Surface

**Certification**

- ASTM A48
- 
- Country of Origin: USA

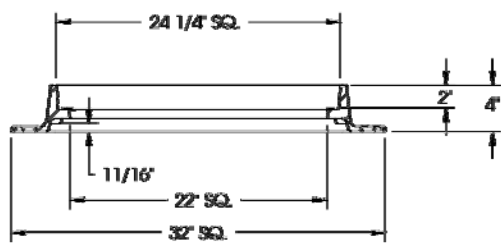

**SECTION A-A**

# TYPICAL FRAME & GRATE





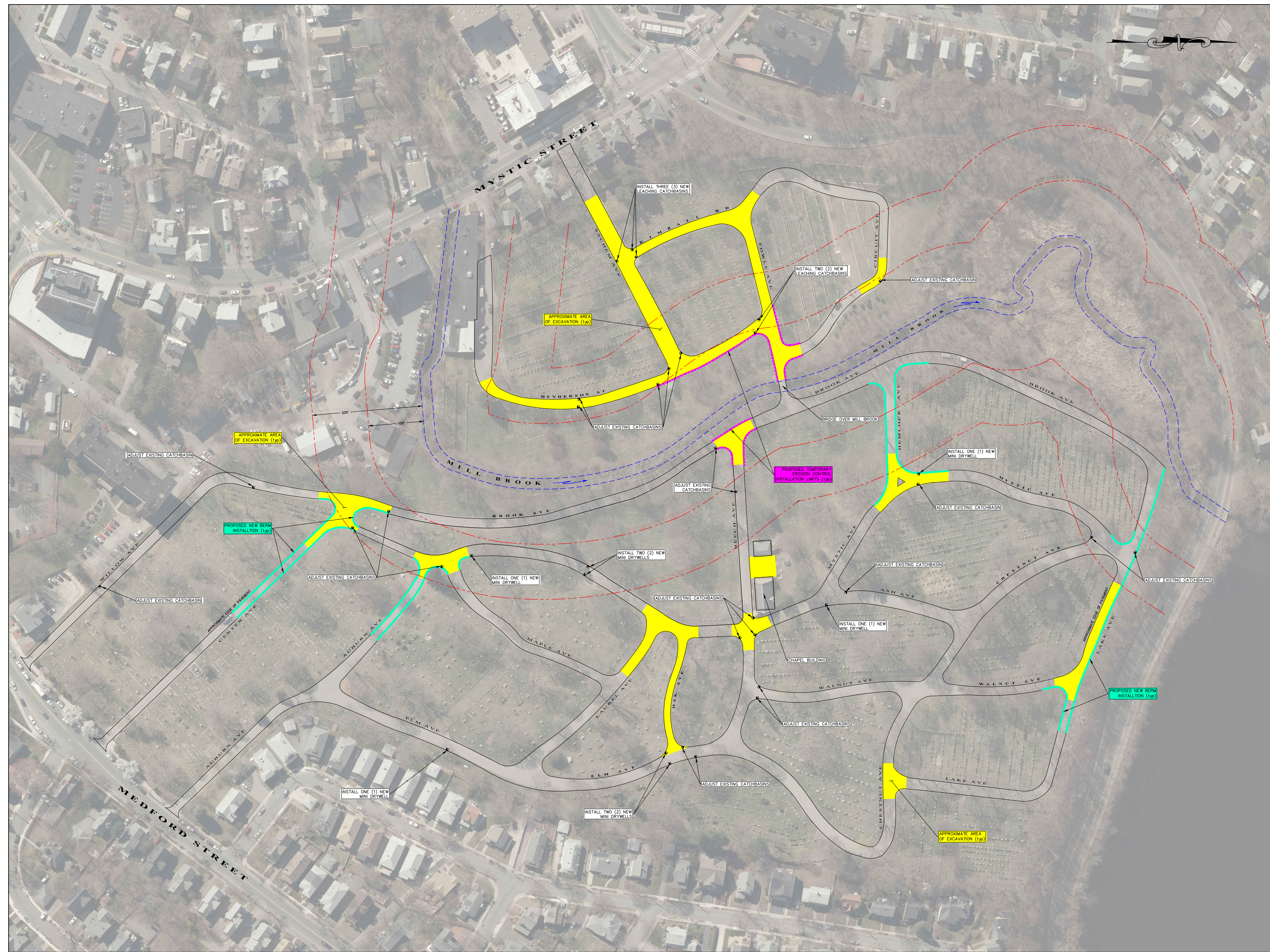

**General Notes**

1. This plan was developed using available aerial imagery, existing plans & on-site observations.
2. An on-the-ground survey was not conducted during the development of this plan. The location and dimensions of features shown on this plan are approximate. It shall be the sole responsibility of the contractor to determine locations of any existing utilities and/or features not shown on this plan.
3. The contractor shall notify the Town of Arlington Engineering Division and/or Water/Sewer Division of all discrepancies from this plan identified in the field.
4. All on-site drainage catch basins shall be equipped with an inlet protection device during all construction activities.
5. Any areas disturbed by the contractor outside the limits of work shall be restored to original condition at no cost to the owner.
6. The contractor must notify all utilities prior to performing any excavation work. The Town of Arlington is not a member of "Dig-Safe" and must be notified directly at least 72-Hours prior to any excavation at 781-316-3310 or 781-316-3301.

No.	Revision/Issue	Date



**Roadway Reconstruction & Related Work**  
for  
**Mt. Pleasant Cemetery**  
Arlington, MA

Project:	BID: 15-23	Sheet:	1 of 1
Drawn By:	KPK		
Scale:	1" = 80'		
Date:	6/1/2015		



## Mount Pleasant Cemetery Reconstruction

Item #	Description	Quantity	Unit	Unit Price	Total
Item # 1	Excavation of Existing Bituminous Surface and Fine Grade	820	CY		
Item # 2	Processed Gravel for Sub Base	175	CY		
Item # 3	Bituminous Binder Course	985	Ton		
Item # 4	Asphalt for Leveling and Miscellaneous	100	Ton		
Item # 5	Gate Box Adjusted	3	Each		
Item # 6	Service Box Adjusted	2	Each		
Item # 7	Drainage Structure/Manhole Adjusted	15	Each		
Item # 7b	Drainage Structure/Manhole Rebuilt	20	VF		
Item # 8	Irrigation Box/Handhole Adjusted	6	Each		
Item # 9	Bituminous Concrete Berm	2000	LF		
Item # 10	Leaching Catch Basin	5	Each		
Item # 11	Mini Dry Well	8	Each		
Item # 12	8" PVC Schedule 40 Pipe	35	LF		

Item #	Description	Quantity	Unit	Unit Price	Total
Item # 13	Frame and Grate	27	Each		
Item # 14	Structure Abandoned	1	Each		
Item # 15	Loam	50	CY		
Item # 16	Seeding	500	SY		

Bid Total
-----------

FIRM NAME: \_\_\_\_\_

ADDRESS: \_\_\_\_\_

PHONE NO: \_\_\_\_\_

FAX NO: \_\_\_\_\_

EMAIL: \_\_\_\_\_

AUTHORIZED SIGNATURE: \_\_\_\_\_

PRINT AUTHORIZED NAME: \_\_\_\_\_

**CERTIFICATE OF NON-COLLUSION**

The undersigned certifies under penalties of perjury that this bid or proposal has been made and submitted in good faith and without collusion or fraud with any other person. As used in this certification, the word "person" shall mean any natural person, business, partnership, corporation, union, committee, club or other organization, entity, or group of individuals.

\_\_\_\_\_  
(Signature of individual submitting bid or proposal)

\_\_\_\_\_  
(Name of individual submitting bid or proposal)

\_\_\_\_\_  
Name of Business

\_\_\_\_\_  
Date

\_\_\_\_\_  
Pursuant to M.G.L. Chapter 62C, Section 49A, I certify under the penalties of perjury that I have complied with all laws of the commonwealth relating to taxes, reporting of employees and contractors, and withholding and remitting child support.

\_\_\_\_\_  
Social Security Number or  
Federal Identification Number

\_\_\_\_\_  
Signature of Individual or Responsible  
Corporate Officer and Title

**NON-COLLUSION FORMS  
MUST BE SIGNED AND  
SUBMITTED WITH BID**

**OSHA TRAINING**

The undersigned hereby certifies that it is able to furnish labor that can work in harmony with all other elements of labor employed or to be employed on the work; that all employees to be employed at the worksite will have successfully completed a course in construction safety and health approved by the United States Occupational Safety and Health Administration that is at least 10 hours in duration at the time the employee begins work and who shall furnish documentation of successful completion of said course with the first certified payroll report for each employee; and that it will comply fully with all laws and regulations applicable to awards made subject to section forty-four A of Chapter 149 of the General Laws.

---

Signature: \_\_\_\_\_

Title: \_\_\_\_\_

Date: \_\_\_\_\_

**From:** "MA Prevailing Wage" <prevailingwages@state.ma.us>  
**To:** dlantzillotti@town.arlington.ma.us  
**Date:** 06/02/2015 03:11 PM  
**Subject:** Prevailing wage schedule for Wage Request number :20150602-072

---

To view and print Weekly Payroll & Statement of Compliance Forms, click on [www.mass.gov/dols/pw](http://www.mass.gov/dols/pw).

PLEASE NOTE: The attached Prevailing Wage Schedule is valid for 90 days. An Awarding Authority should re-request an up to date Prevailing Wage Schedule if it has NOT opened bids or selected a contractor within 90 days of the issuance date of the attached prevailing wage schedule.

\*For MULTI-YEAR projects bid on or after 8/8/08, Awarding Authorities must request an Annual Update to this Prevailing Wage Schedule each year for the duration of the project, no later than two weeks before the anniversary date of the execution of the general contract. Annual updates are not required for projects that last LESS THAN ONE YEAR.

\*For CM AT RISK projects (bid pursuant to GL c.149A), Awarding Authorities must request a Prevailing Wage Schedule NOT sooner than 90-days before the earlier of: (a) the execution date of the GMP Amendment, or (b) the bid for the first construction scope of work.

\*For MULTI-YEAR CM AT RISK projects, Awarding Authorities must request an Annual Update to this Prevailing Wage Schedule each year for the duration of the project, no later than two weeks before the anniversary date, which is the earlier of: (a) the execution date of the GMP Amendment, or (b) the execution date of the first amendment to procure construction scopes of work.

Apprentice wages (expressed as dollar figures) and the required benefits are listed on the Prevailing Wage Schedule. For further details, please see opinion letter PW-2010-03-03.16.10 (dated March 18, 2010) at [www.mass.gov/dols/pw](http://www.mass.gov/dols/pw).

Request Prevailing Wage Rates online at: [www.mass.gov/dols/pw](http://www.mass.gov/dols/pw).

THIS IS A SYSTEM-GENERATED EMAIL. PLEASE DO NOT REPLY TO THIS EMAIL.  
TO CONTACT DLS REGARDING PREVAILING WAGE MATTERS, CALL 617-626-6953.

---

APPROVAL/DENIAL COMMENTS

This e-mail message, including any attachments, is for the sole use of the intended recipient(s) and may contain confidential and privileged information. Any unauthorized review, use, disclosure, or distribution is strictly prohibited and may be the subject of legal action. If you are not the intended recipient, please contact the sender by reply

e-mail and destroy all copies of the original message. Thank you.

**Attachments:**

File: [20150602-072.pdf](#)    Size: 168k    Content Type: application/pdf



**THE COMMONWEALTH OF MASSACHUSETTS  
EXECUTIVE OFFICE OF LABOR AND WORKFORCE DEVELOPMENT  
DEPARTMENT OF LABOR STANDARDS**

**Prevailing Wage Rates**

**As determined by the Director under the provisions of the  
Massachusetts General Laws, Chapter 149, Sections 26 to 27H**

CHARLES D. BAKER  
Governor

RONALD L. WALKER, II  
Secretary

KARYN E. POLITO  
Lt. Governor

JEAN ZEILER  
Acting Director

**Awarding Authority:** Town of Arlington  
**Contract Number:** 15-23 **City/Town:** ARLINGTON  
**Description of Work:** Furnish all labor, materials, equipment and supervision necessary for reconstruction & related work of roadways at Mt. Pleasant Cemetery.  
**Job Location:** 70 Medford Street

Information about Prevailing Wage Schedules for Awarding Authorities and Contractors

- This wage schedule applies only to the specific project referenced at the top of this page and uniquely identified by the “Wage Request Number” on all pages of this schedule.
- An Awarding Authority must request an updated wage schedule from the Department of Labor Standards (“DLS”) if it has not opened bids or selected a contractor within 90 days of the date of issuance of the wage schedule. For CM AT RISK projects (bid pursuant to G.L. c.149A), the earlier of: (a) the execution date of the GMP Amendment, or (b) the bid for the first construction scope of work must be within 90-days of the wage schedule issuance date.
- The wage schedule shall be incorporated in any advertisement or call for bids for the project as required by M.G.L. c. 149, § 27. The wage schedule shall be made a part of the contract awarded for the project. The wage schedule must be posted in a conspicuous place at the work site for the life of the project in accordance with M.G.L. c. 149 § 27. The wages listed on the wage schedule must be paid to employees performing construction work on the project whether they are employed by the prime contractor, a filed sub-bidder, or any sub-contractor.
- All apprentices working on the project are required to be registered with the Massachusetts Division of Apprentice Standards (DAS). Apprentice must keep his/her apprentice identification card on his/her person during all work hours on the project. An apprentice registered with DAS may be paid the lower apprentice wage rate at the applicable step as provided on the prevailing wage schedule. **If an apprentice rate is not listed on the prevailing wage schedule for the trade in which an apprentice is registered with the DAS, the apprentice must be paid the journeyworker's rate for the trade.**
- The wage rates will remain in effect for the duration of the project, except in the case of multi-year public construction projects. For construction projects lasting longer than one year, awarding authorities must request an updated wage schedule. Awarding authorities are required to request these updates no later than two weeks before the anniversary of the date the contract was executed by the awarding authority and the general contractor. For multi-year CM AT RISK projects, awarding authority must request an annual update no later than two weeks before the anniversary date, determined as the earlier of: (a) the execution date of the GMP Amendment, or (b) the execution date of the first amendment to permit procurement of construction services. Contractors are required to obtain the wage schedules from awarding authorities, and to pay no less than these rates to covered workers. The annual update requirement is not applicable to 27F “rental of equipment” contracts.
- Every contractor or subcontractor which performs construction work on the project is required to submit weekly payroll reports and a Statement of Compliance directly to the awarding authority by mail or email and keep them on file for three years. Each weekly payroll report must contain: the employee’s name, address, occupational classification, hours worked, and wages paid. Do not submit weekly payroll reports to DLS. A sample of a payroll reporting form may be obtained at <http://www.mass.gov/dols/pw>.
- Contractors with questions about the wage rates or classifications included on the wage schedule have an affirmative obligation to inquire with DLS at (617) 626-6953.
- Employees not receiving the prevailing wage rate set forth on the wage schedule may report the violation to the Fair Labor Division of the office of the Attorney General at (617) 727-3465.
- Failure of a contractor or subcontractor to pay the prevailing wage rates listed on the wage schedule to all employees who perform construction work on the project is a violation of the law and subjects the contractor or subcontractor to civil and criminal penalties.



Classification	Effective Date	Base Wage	Health	Pension	Supplemental Unemployment	Total Rate
<b>Construction</b>						
(2 AXLE) DRIVER - EQUIPMENT <i>TEAMSTERS JOINT COUNCIL NO. 10 ZONE A</i>	06/01/2015	\$32.75	\$9.91	\$9.33	\$0.00	\$51.99
	08/01/2015	\$32.75	\$10.41	\$9.33	\$0.00	\$52.49
	12/01/2015	\$32.75	\$10.41	\$10.08	\$0.00	\$53.24
	06/01/2016	\$33.25	\$10.41	\$10.08	\$0.00	\$53.74
	08/01/2016	\$33.25	\$10.91	\$10.08	\$0.00	\$54.24
	12/01/2016	\$33.25	\$10.91	\$10.89	\$0.00	\$55.05
(3 AXLE) DRIVER - EQUIPMENT <i>TEAMSTERS JOINT COUNCIL NO. 10 ZONE A</i>	06/01/2015	\$32.82	\$9.91	\$9.33	\$0.00	\$52.06
	08/01/2015	\$32.82	\$10.41	\$9.33	\$0.00	\$52.56
	12/01/2015	\$32.82	\$10.41	\$10.08	\$0.00	\$53.31
	06/01/2016	\$33.32	\$10.41	\$10.08	\$0.00	\$53.81
	08/01/2016	\$33.32	\$10.91	\$10.08	\$0.00	\$54.31
	12/01/2016	\$33.32	\$10.91	\$10.89	\$0.00	\$55.12
(4 & 5 AXLE) DRIVER - EQUIPMENT <i>TEAMSTERS JOINT COUNCIL NO. 10 ZONE A</i>	06/01/2015	\$32.94	\$9.91	\$9.33	\$0.00	\$52.18
	08/01/2015	\$32.94	\$10.41	\$9.33	\$0.00	\$52.68
	12/01/2015	\$32.94	\$10.41	\$10.08	\$0.00	\$53.43
	06/01/2016	\$33.44	\$10.41	\$10.08	\$0.00	\$53.93
	08/01/2016	\$33.44	\$10.91	\$10.08	\$0.00	\$54.43
	12/01/2016	\$33.44	\$10.91	\$10.89	\$0.00	\$55.24
ADS/SUBMERSIBLE PILOT <i>PILE DRIVER LOCAL 56 (ZONE 1)</i>	08/01/2014	\$87.36	\$9.80	\$18.17	\$0.00	\$115.33
	08/01/2015	\$90.51	\$9.80	\$18.17	\$0.00	\$118.48
AIR TRACK OPERATOR <i>LABORERS - ZONE 1</i>	06/01/2015	\$36.10	\$7.30	\$12.95	\$0.00	\$56.35
	12/01/2015	\$36.85	\$7.30	\$12.95	\$0.00	\$57.10
	06/01/2016	\$37.60	\$7.30	\$12.95	\$0.00	\$57.85
	12/01/2016	\$38.60	\$7.30	\$12.95	\$0.00	\$58.85
For apprentice rates see "Apprentice- LABORER"						
ASBESTOS REMOVER - PIPE / MECH. EQUIPT. <i>HEAT &amp; FROST INSULATORS LOCAL 6 (BOSTON)</i>	06/01/2015	\$33.43	\$10.40	\$5.95	\$0.00	\$49.78
	12/01/2015	\$34.38	\$10.40	\$5.95	\$0.00	\$50.73
ASPHALT RAKER <i>LABORERS - ZONE 1</i>	06/01/2015	\$35.60	\$7.30	\$12.95	\$0.00	\$55.85
	12/01/2015	\$36.35	\$7.30	\$12.95	\$0.00	\$56.60
	06/01/2016	\$37.10	\$7.30	\$12.95	\$0.00	\$57.35
	12/01/2016	\$38.10	\$7.30	\$12.95	\$0.00	\$58.35
For apprentice rates see "Apprentice- LABORER"						
ASPHALT/CONCRETE/CRUSHER PLANT-ON SITE <i>OPERATING ENGINEERS LOCAL 4</i>	06/01/2015	\$42.83	\$10.00	\$14.55	\$0.00	\$67.38
	12/01/2015	\$44.08	\$10.00	\$14.55	\$0.00	\$68.63
	06/01/2016	\$44.83	\$10.00	\$14.55	\$0.00	\$69.38
	12/01/2016	\$46.08	\$10.00	\$14.55	\$0.00	\$70.63
	06/01/2017	\$47.08	\$10.00	\$14.55	\$0.00	\$71.63
	12/01/2017	\$48.08	\$10.00	\$14.55	\$0.00	\$72.63
For apprentice rates see "Apprentice- OPERATING ENGINEERS"						
BACKHOE/FRONT-END LOADER <i>OPERATING ENGINEERS LOCAL 4</i>	06/01/2015	\$42.83	\$10.00	\$14.55	\$0.00	\$67.38
	12/01/2015	\$44.08	\$10.00	\$14.55	\$0.00	\$68.63
	06/01/2016	\$44.83	\$10.00	\$14.55	\$0.00	\$69.38
	12/01/2016	\$46.08	\$10.00	\$14.55	\$0.00	\$70.63
	06/01/2017	\$47.08	\$10.00	\$14.55	\$0.00	\$71.63
	12/01/2017	\$48.08	\$10.00	\$14.55	\$0.00	\$72.63

Classification	Effective Date	Base Wage	Health	Pension	Supplemental Unemployment	Total Rate
For apprentice rates see "Apprentice- OPERATING ENGINEERS"						
BARCO-TYPE JUMPING TAMPER <i>LABORERS - ZONE 1</i>	06/01/2015	\$35.60	\$7.30	\$12.95	\$0.00	\$55.85
	12/01/2015	\$36.35	\$7.30	\$12.95	\$0.00	\$56.60
	06/01/2016	\$37.10	\$7.30	\$12.95	\$0.00	\$57.35
	12/01/2016	\$38.10	\$7.30	\$12.95	\$0.00	\$58.35
For apprentice rates see "Apprentice- LABORER"						
BLOCK PAVER, RAMMER / CURB SETTER <i>LABORERS - ZONE 1</i>	06/01/2015	\$36.10	\$7.30	\$12.95	\$0.00	\$56.35
	12/01/2015	\$36.85	\$7.30	\$12.95	\$0.00	\$57.10
	06/01/2016	\$37.60	\$7.30	\$12.95	\$0.00	\$57.85
	12/01/2016	\$38.60	\$7.30	\$12.95	\$0.00	\$58.85
For apprentice rates see "Apprentice- LABORER"						
BOILER MAKER <i>BOILERMAKERS LOCAL 29</i>	01/01/2010	\$37.70	\$6.97	\$11.18	\$0.00	\$55.85

**Apprentice - BOILERMAKER - Local 29**

**Effective Date - 01/01/2010**

Step	percent	Apprentice Base Wage	Health	Pension	Supplemental Unemployment	Total Rate
1	65	\$24.51	\$6.97	\$11.18	\$0.00	\$42.66
2	65	\$24.51	\$6.97	\$11.18	\$0.00	\$42.66
3	70	\$26.39	\$6.97	\$11.18	\$0.00	\$44.54
4	75	\$28.28	\$6.97	\$11.18	\$0.00	\$46.43
5	80	\$30.16	\$6.97	\$11.18	\$0.00	\$48.31
6	85	\$32.05	\$6.97	\$11.18	\$0.00	\$50.20
7	90	\$33.93	\$6.97	\$11.18	\$0.00	\$52.08
8	95	\$35.82	\$6.97	\$11.18	\$0.00	\$53.97

**Notes:**

**Apprentice to Journeyworker Ratio:1:5**

BRICK/STONE/ARTIFICIAL MASONRY (INCL. MASONRY WATERPROOFING) <i>BRICKLAYERS LOCAL 3 (BOSTON)</i>	02/01/2015	\$48.96	\$10.18	\$18.50	\$0.00	\$77.64
	08/01/2015	\$49.86	\$10.18	\$18.57	\$0.00	\$78.61
	02/01/2016	\$50.43	\$10.18	\$18.57	\$0.00	\$79.18
	08/01/2016	\$51.33	\$10.18	\$18.65	\$0.00	\$80.16
	02/01/2017	\$51.90	\$10.18	\$18.65	\$0.00	\$80.73

**Classification**

**Effective Date   Base Wage   Health   Pension   Supplemental Unemployment   Total Rate**

**Apprentice - BRICK/PLASTER/CEMENT MASON - Local 3 Boston**

**Effective Date - 02/01/2015**

Step	percent	Apprentice Base Wage	Health	Pension	Supplemental Unemployment	Total Rate
1	50	\$24.48	\$10.18	\$18.50	\$0.00	\$53.16
2	60	\$29.38	\$10.18	\$18.50	\$0.00	\$58.06
3	70	\$34.27	\$10.18	\$18.50	\$0.00	\$62.95
4	80	\$39.17	\$10.18	\$18.50	\$0.00	\$67.85
5	90	\$44.06	\$10.18	\$18.50	\$0.00	\$72.74

**Effective Date - 08/01/2015**

Step	percent	Apprentice Base Wage	Health	Pension	Supplemental Unemployment	Total Rate
1	50	\$24.93	\$10.18	\$18.57	\$0.00	\$53.68
2	60	\$29.92	\$10.18	\$18.57	\$0.00	\$58.67
3	70	\$34.90	\$10.18	\$18.57	\$0.00	\$63.65
4	80	\$39.89	\$10.18	\$18.57	\$0.00	\$68.64
5	90	\$44.87	\$10.18	\$18.57	\$0.00	\$73.62

**Notes:**

**Apprentice to Journeyworker Ratio:1:5**

<b>BULLDOZER/GRADER/SCRAPER</b>	06/01/2015	\$42.42	\$10.00	\$14.55	\$0.00	\$66.97
<i>OPERATING ENGINEERS LOCAL 4</i>	12/01/2015	\$43.66	\$10.00	\$14.55	\$0.00	\$68.21
	06/01/2016	\$44.41	\$10.00	\$14.55	\$0.00	\$68.96
	12/01/2016	\$45.64	\$10.00	\$14.55	\$0.00	\$70.19
	06/01/2017	\$46.63	\$10.00	\$14.55	\$0.00	\$71.18
	12/01/2017	\$47.62	\$10.00	\$14.55	\$0.00	\$72.17

For apprentice rates see "Apprentice- OPERATING ENGINEERS"

<b>CAISSON &amp; UNDERPINNING BOTTOM MAN</b>	06/01/2015	\$36.45	\$7.30	\$13.15	\$0.00	\$56.90
<i>LABORERS - FOUNDATION AND MARINE</i>	12/01/2015	\$37.20	\$7.30	\$13.15	\$0.00	\$57.65
	06/01/2016	\$37.95	\$7.30	\$13.15	\$0.00	\$58.40
	12/01/2016	\$38.95	\$7.30	\$13.15	\$0.00	\$59.40

For apprentice rates see "Apprentice- LABORER"

<b>CAISSON &amp; UNDERPINNING LABORER</b>	06/01/2015	\$35.30	\$7.30	\$13.15	\$0.00	\$55.75
<i>LABORERS - FOUNDATION AND MARINE</i>	12/01/2015	\$36.05	\$7.30	\$13.15	\$0.00	\$56.50
	06/01/2016	\$36.80	\$7.30	\$13.15	\$0.00	\$57.25
	12/01/2016	\$37.80	\$7.30	\$13.15	\$0.00	\$58.25

For apprentice rates see "Apprentice- LABORER"

<b>CAISSON &amp; UNDERPINNING TOP MAN</b>	06/01/2015	\$35.30	\$7.30	\$13.15	\$0.00	\$55.75
<i>LABORERS - FOUNDATION AND MARINE</i>	12/01/2015	\$36.05	\$7.30	\$13.15	\$0.00	\$56.50
	06/01/2016	\$36.80	\$7.30	\$13.15	\$0.00	\$57.25
	12/01/2016	\$37.80	\$7.30	\$13.15	\$0.00	\$58.25

For apprentice rates see "Apprentice- LABORER"

Classification	Effective Date	Base Wage	Health	Pension	Supplemental Unemployment	Total Rate
CARBIDE CORE DRILL OPERATOR <i>LABORERS - ZONE 1</i>	06/01/2015	\$35.60	\$7.30	\$12.95	\$0.00	\$55.85
	12/01/2015	\$36.35	\$7.30	\$12.95	\$0.00	\$56.60
	06/01/2016	\$37.10	\$7.30	\$12.95	\$0.00	\$57.35
	12/01/2016	\$38.10	\$7.30	\$12.95	\$0.00	\$58.35
For apprentice rates see "Apprentice- LABORER"						
CARPENTER <i>CARPENTERS -ZONE 2 (Eastern Massachusetts)</i>	03/01/2015	\$35.75	\$9.80	\$16.48	\$0.00	\$62.03

**Apprentice - CARPENTER - Zone 2 Eastern MA**

**Effective Date - 03/01/2015**

Step	percent	Apprentice Base Wage	Health	Pension	Supplemental Unemployment	Total Rate
1	50	\$17.88	\$9.80	\$1.63	\$0.00	\$29.31
2	60	\$21.45	\$9.80	\$1.63	\$0.00	\$32.88
3	70	\$25.03	\$9.80	\$11.59	\$0.00	\$46.42
4	75	\$26.81	\$9.80	\$11.59	\$0.00	\$48.20
5	80	\$28.60	\$9.80	\$13.22	\$0.00	\$51.62
6	80	\$28.60	\$9.80	\$13.22	\$0.00	\$51.62
7	90	\$32.18	\$9.80	\$14.85	\$0.00	\$56.83
8	90	\$32.18	\$9.80	\$14.85	\$0.00	\$56.83

**Notes:**

**Apprentice to Journeyworker Ratio:1:5**

CEMENT MASONRY/PLASTERING <i>BRICKLAYERS LOCAL 3 (BOSTON)</i>	01/01/2015	\$44.90	\$10.90	\$18.71	\$1.30	\$75.81
	07/01/2015	\$45.82	\$10.90	\$18.71	\$1.30	\$76.73
	01/01/2016	\$46.44	\$10.90	\$18.71	\$1.30	\$77.35

**Classification**

**Effective Date   Base Wage   Health   Pension   Supplemental Unemployment   Total Rate**

**Apprentice - CEMENT MASONRY/PLASTERING - Eastern Mass (Boston)**

**Effective Date - 01/01/2015**

Step	percent	Apprentice Base Wage	Health	Pension	Supplemental Unemployment	Total Rate
1	50	\$22.45	\$10.90	\$12.21	\$0.00	\$45.56
2	60	\$26.94	\$10.90	\$13.71	\$1.30	\$52.85
3	65	\$29.19	\$10.90	\$14.71	\$1.30	\$56.10
4	70	\$31.43	\$10.90	\$15.71	\$1.30	\$59.34
5	75	\$33.68	\$10.90	\$16.71	\$1.30	\$62.59
6	80	\$35.92	\$10.90	\$17.71	\$1.30	\$65.83
7	90	\$40.41	\$10.90	\$18.71	\$1.30	\$71.32

**Effective Date - 07/01/2015**

Step	percent	Apprentice Base Wage	Health	Pension	Supplemental Unemployment	Total Rate
1	50	\$22.91	\$10.90	\$12.21	\$0.00	\$46.02
2	60	\$27.49	\$10.90	\$13.71	\$1.30	\$53.40
3	65	\$29.78	\$10.90	\$14.71	\$1.30	\$56.69
4	70	\$32.07	\$10.90	\$15.71	\$1.30	\$59.98
5	75	\$34.37	\$10.90	\$16.71	\$1.30	\$63.28
6	80	\$36.66	\$10.90	\$17.71	\$1.30	\$66.57
7	90	\$41.24	\$10.90	\$18.71	\$1.30	\$72.15

**Notes:**

Steps 3,4 are 500 hrs. All other steps are 1,000 hrs.

**Apprentice to Journeyworker Ratio:1:3**

CHAIN SAW OPERATOR	06/01/2015	\$35.60	\$7.30	\$12.95	\$0.00	\$55.85
LABORERS - ZONE 1	12/01/2015	\$36.35	\$7.30	\$12.95	\$0.00	\$56.60
	06/01/2016	\$37.10	\$7.30	\$12.95	\$0.00	\$57.35
	12/01/2016	\$38.10	\$7.30	\$12.95	\$0.00	\$58.35

For apprentice rates see "Apprentice- LABORER"

CLAM SHELLS/SLURRY BUCKETS/HEADING MACHINES	06/01/2015	\$43.83	\$10.00	\$14.55	\$0.00	\$68.38
OPERATING ENGINEERS LOCAL 4	12/01/2015	\$45.08	\$10.00	\$14.55	\$0.00	\$69.63
	06/01/2016	\$45.83	\$10.00	\$14.55	\$0.00	\$70.38
	12/01/2016	\$47.08	\$10.00	\$14.55	\$0.00	\$71.63
	06/01/2017	\$48.08	\$10.00	\$14.55	\$0.00	\$72.63
	12/01/2017	\$49.08	\$10.00	\$14.55	\$0.00	\$73.63

For apprentice rates see "Apprentice- OPERATING ENGINEERS"

COMPRESSOR OPERATOR	06/01/2015	\$29.61	\$10.00	\$14.55	\$0.00	\$54.16
OPERATING ENGINEERS LOCAL 4	12/01/2015	\$30.48	\$10.00	\$14.55	\$0.00	\$55.03
	06/01/2016	\$31.00	\$10.00	\$14.55	\$0.00	\$55.55
	12/01/2016	\$31.87	\$10.00	\$14.55	\$0.00	\$56.42
	06/01/2017	\$32.56	\$10.00	\$14.55	\$0.00	\$57.11
	12/01/2017	\$33.25	\$10.00	\$14.55	\$0.00	\$57.80

For apprentice rates see "Apprentice- OPERATING ENGINEERS"

Classification	Effective Date	Base Wage	Health	Pension	Supplemental Unemployment	Total Rate
DELEADER (BRIDGE) PAINTERS LOCAL 35 - ZONE 2	01/01/2015	\$47.66	\$7.85	\$16.10	\$0.00	\$71.61
	07/01/2015	\$48.56	\$7.85	\$16.10	\$0.00	\$72.51
	01/01/2016	\$49.51	\$7.85	\$16.10	\$0.00	\$73.46
	07/01/2016	\$50.46	\$7.85	\$16.10	\$0.00	\$74.41
	01/01/2017	\$51.41	\$7.85	\$16.10	\$0.00	\$75.36

**Apprentice - PAINTER Local 35 - BRIDGES/TANKS**

**Effective Date - 01/01/2015**

Step	percent	Apprentice Base Wage	Health	Pension	Supplemental Unemployment	Total Rate
1	50	\$23.83	\$7.85	\$0.00	\$0.00	\$31.68
2	55	\$26.21	\$7.85	\$3.66	\$0.00	\$37.72
3	60	\$28.60	\$7.85	\$3.99	\$0.00	\$40.44
4	65	\$30.98	\$7.85	\$4.32	\$0.00	\$43.15
5	70	\$33.36	\$7.85	\$14.11	\$0.00	\$55.32
6	75	\$35.75	\$7.85	\$14.44	\$0.00	\$58.04
7	80	\$38.13	\$7.85	\$14.77	\$0.00	\$60.75
8	90	\$42.89	\$7.85	\$15.44	\$0.00	\$66.18

**Effective Date - 07/01/2015**

Step	percent	Apprentice Base Wage	Health	Pension	Supplemental Unemployment	Total Rate
1	50	\$24.28	\$7.85	\$0.00	\$0.00	\$32.13
2	55	\$26.71	\$7.85	\$3.66	\$0.00	\$38.22
3	60	\$29.14	\$7.85	\$3.99	\$0.00	\$40.98
4	65	\$31.56	\$7.85	\$4.32	\$0.00	\$43.73
5	70	\$33.99	\$7.85	\$14.11	\$0.00	\$55.95
6	75	\$36.42	\$7.85	\$14.44	\$0.00	\$58.71
7	80	\$38.85	\$7.85	\$14.77	\$0.00	\$61.47
8	90	\$43.70	\$7.85	\$15.44	\$0.00	\$66.99

**Notes:**

Steps are 750 hrs.

**Apprentice to Journeyworker Ratio:1:1**

DEMO: ADZEMAN LABORERS - ZONE 1	06/01/2015	\$35.50	\$7.30	\$12.95	\$0.00	\$55.75
	12/01/2015	\$36.25	\$7.30	\$12.95	\$0.00	\$56.50
For apprentice rates see "Apprentice- LABORER"						
DEMO: BACKHOE/LOADER/HAMMER OPERATOR LABORERS - ZONE 1	06/01/2015	\$36.50	\$7.30	\$12.95	\$0.00	\$56.75
	12/01/2015	\$37.25	\$7.30	\$12.95	\$0.00	\$57.50
For apprentice rates see "Apprentice- LABORER"						
DEMO: BURNERS LABORERS - ZONE 1	06/01/2015	\$36.25	\$7.30	\$12.95	\$0.00	\$56.50
	12/01/2015	\$37.00	\$7.30	\$12.95	\$0.00	\$57.25
For apprentice rates see "Apprentice- LABORER"						
DEMO: CONCRETE CUTTER/SAWYER LABORERS - ZONE 1	06/01/2015	\$36.50	\$7.30	\$12.95	\$0.00	\$56.75
	12/01/2015	\$37.25	\$7.30	\$12.95	\$0.00	\$57.50
For apprentice rates see "Apprentice- LABORER"						

Classification	Effective Date	Base Wage	Health	Pension	Supplemental Unemployment	Total Rate
DEMO: JACKHAMMER OPERATOR <i>LABORERS - ZONE 1</i>	06/01/2015	\$36.25	\$7.30	\$12.95	\$0.00	\$56.50
	12/01/2015	\$37.00	\$7.30	\$12.95	\$0.00	\$57.25
For apprentice rates see "Apprentice- LABORER"						
DEMO: WRECKING LABORER <i>LABORERS - ZONE 1</i>	06/01/2015	\$35.50	\$7.30	\$12.95	\$0.00	\$55.75
	12/01/2015	\$36.25	\$7.30	\$12.95	\$0.00	\$56.50
For apprentice rates see "Apprentice- LABORER"						
DIRECTIONAL DRILL MACHINE OPERATOR <i>OPERATING ENGINEERS LOCAL 4</i>	06/01/2015	\$42.42	\$10.00	\$14.55	\$0.00	\$66.97
	12/01/2015	\$43.66	\$10.00	\$14.55	\$0.00	\$68.21
	06/01/2016	\$44.41	\$10.00	\$14.55	\$0.00	\$68.96
	12/01/2016	\$45.64	\$10.00	\$14.55	\$0.00	\$70.19
	06/01/2017	\$46.63	\$10.00	\$14.55	\$0.00	\$71.18
	12/01/2017	\$47.62	\$10.00	\$14.55	\$0.00	\$72.17
For apprentice rates see "Apprentice- OPERATING ENGINEERS"						
DIVER <i>PILE DRIVER LOCAL 56 (ZONE 1)</i>	08/01/2014	\$58.24	\$9.80	\$18.17	\$0.00	\$86.21
	08/01/2015	\$60.34	\$9.80	\$18.17	\$0.00	\$88.31
DIVER TENDER <i>PILE DRIVER LOCAL 56 (ZONE 1)</i>	08/01/2014	\$41.60	\$9.80	\$18.17	\$0.00	\$69.57
	08/01/2015	\$43.10	\$9.80	\$18.17	\$0.00	\$71.07
DIVER TENDER (EFFLUENT) <i>PILE DRIVER LOCAL 56 (ZONE 1)</i>	08/01/2014	\$62.40	\$9.80	\$18.17	\$0.00	\$90.37
	08/01/2015	\$64.65	\$9.80	\$18.17	\$0.00	\$92.62
DIVER/SLURRY (EFFLUENT) <i>PILE DRIVER LOCAL 56 (ZONE 1)</i>	08/01/2014	\$87.36	\$9.80	\$18.17	\$0.00	\$115.33
	08/01/2015	\$90.51	\$9.80	\$18.17	\$0.00	\$118.48
DRAWBRIDGE OPERATOR (Construction) <i>ELECTRICIANS LOCAL 103</i>	03/01/2015	\$45.17	\$13.00	\$15.40	\$0.00	\$73.57
	09/01/2015	\$46.13	\$13.00	\$15.43	\$0.00	\$74.56
	03/01/2016	\$47.08	\$13.00	\$15.46	\$0.00	\$75.54
For apprentice rates see "Apprentice- ELECTRICIAN"						
ELECTRICIAN <i>ELECTRICIANS LOCAL 103</i>	03/01/2015	\$45.17	\$13.00	\$15.40	\$0.00	\$73.57
	09/01/2015	\$46.13	\$13.00	\$15.43	\$0.00	\$74.56
	03/01/2016	\$47.08	\$13.00	\$15.46	\$0.00	\$75.54

**Apprentice - ELECTRICIAN - Local 103**

**Effective Date - 03/01/2015**

Step	percent	Apprentice Base Wage	Health	Pension	Supplemental Unemployment	Total Rate
1	40	\$18.07	\$13.00	\$0.54	\$0.00	\$31.61
2	40	\$18.07	\$13.00	\$0.54	\$0.00	\$31.61
3	45	\$20.33	\$13.00	\$11.64	\$0.00	\$44.97
4	45	\$20.33	\$13.00	\$11.64	\$0.00	\$44.97
5	50	\$22.59	\$13.00	\$11.98	\$0.00	\$47.57
6	55	\$24.84	\$13.00	\$12.33	\$0.00	\$50.17
7	60	\$27.10	\$13.00	\$12.66	\$0.00	\$52.76
8	65	\$29.36	\$13.00	\$13.01	\$0.00	\$55.37
9	70	\$31.62	\$13.00	\$13.35	\$0.00	\$57.97
10	75	\$33.88	\$13.00	\$13.70	\$0.00	\$60.58

**Effective Date - 09/01/2015**

Step	percent	Apprentice Base Wage	Health	Pension	Supplemental Unemployment	Total Rate
1	40	\$18.45	\$13.00	\$0.55	\$0.00	\$32.00
2	40	\$18.45	\$13.00	\$0.55	\$0.00	\$32.00
3	45	\$20.76	\$13.00	\$11.65	\$0.00	\$45.41
4	45	\$20.76	\$13.00	\$11.65	\$0.00	\$45.41
5	50	\$23.07	\$13.00	\$11.99	\$0.00	\$48.06
6	55	\$25.37	\$13.00	\$12.34	\$0.00	\$50.71
7	60	\$27.68	\$13.00	\$12.68	\$0.00	\$53.36
8	65	\$29.98	\$13.00	\$13.03	\$0.00	\$56.01
9	70	\$32.29	\$13.00	\$13.37	\$0.00	\$58.66
10	75	\$34.60	\$13.00	\$13.72	\$0.00	\$61.32

**Notes :**  
App Prior 1/1/03; 30/35/40/45/50/55/65/70/75/80

**Apprentice to Journeyworker Ratio:2:3\*\*\***

ELEVATOR CONSTRUCTOR	01/01/2015	\$53.30	\$13.58	\$14.21	\$0.00	\$81.09
ELEVATOR CONSTRUCTORS LOCAL 4	01/01/2016	\$54.53	\$14.43	\$14.96	\$0.00	\$83.92
	01/01/2017	\$55.86	\$15.28	\$15.71	\$0.00	\$86.85



**Classification**

**Effective Date   Base Wage   Health   Pension   Supplemental Unemployment   Total Rate**

**Apprentice - ELEVATOR CONSTRUCTOR - Local 4**

**Effective Date - 01/01/2015**

Step	percent	Apprentice Base Wage	Health	Pension	Supplemental Unemployment	Total Rate
1	50	\$26.65	\$13.58	\$0.00	\$0.00	\$40.23
2	55	\$29.32	\$13.58	\$14.21	\$0.00	\$57.11
3	65	\$34.65	\$13.58	\$14.21	\$0.00	\$62.44
4	70	\$37.31	\$13.58	\$14.21	\$0.00	\$65.10
5	80	\$42.64	\$13.58	\$14.21	\$0.00	\$70.43

**Effective Date - 01/01/2016**

Step	percent	Apprentice Base Wage	Health	Pension	Supplemental Unemployment	Total Rate
1	50	\$27.27	\$14.43	\$0.00	\$0.00	\$41.70
2	55	\$29.99	\$14.43	\$14.96	\$0.00	\$59.38
3	65	\$35.44	\$14.43	\$14.96	\$0.00	\$64.83
4	70	\$38.17	\$14.43	\$14.96	\$0.00	\$67.56
5	80	\$43.62	\$14.43	\$14.96	\$0.00	\$73.01

**Notes:**  
Steps 1-2 are 6 mos.; Steps 3-5 are 1 year

**Apprentice to Journeyworker Ratio:1:1**

ELEVATOR CONSTRUCTOR HELPER <i>ELEVATOR CONSTRUCTORS LOCAL 4</i>	01/01/2015	\$37.31	\$13.58	\$14.21	\$0.00	\$65.10
	01/01/2016	\$38.17	\$14.43	\$14.96	\$0.00	\$67.56
	01/01/2017	\$39.10	\$15.28	\$15.71	\$0.00	\$70.09

For apprentice rates see "Apprentice - ELEVATOR CONSTRUCTOR"

FENCE & GUARD RAIL ERECTOR <i>LABORERS - ZONE 1</i>	06/01/2015	\$35.60	\$7.30	\$12.95	\$0.00	\$55.85
	12/01/2015	\$36.35	\$7.30	\$12.95	\$0.00	\$56.60
	06/01/2016	\$37.10	\$7.30	\$12.95	\$0.00	\$57.35
	12/01/2016	\$38.10	\$7.30	\$12.95	\$0.00	\$58.35

For apprentice rates see "Apprentice- LABORER"

FIELD ENG.INST.PERSON-BLDG,SITE,HVY/HWY <i>OPERATING ENGINEERS LOCAL 4</i>	05/01/2015	\$40.22	\$10.00	\$14.30	\$0.00	\$64.52
	11/01/2015	\$40.80	\$10.00	\$14.30	\$0.00	\$65.10
	05/01/2016	\$41.69	\$10.00	\$14.30	\$0.00	\$65.99
	11/01/2016	\$42.28	\$10.00	\$14.30	\$0.00	\$66.58
	05/01/2017	\$43.16	\$10.00	\$14.30	\$0.00	\$67.46
	11/01/2017	\$43.89	\$10.00	\$14.30	\$0.00	\$68.19
	05/01/2018	\$44.60	\$10.00	\$14.30	\$0.00	\$68.90

For apprentice rates see "Apprentice- OPERATING ENGINEERS"

FIELD ENG.PARTY CHIEF-BLDG,SITE,HVY/HWY <i>OPERATING ENGINEERS LOCAL 4</i>	05/01/2015	\$41.65	\$10.00	\$14.30	\$0.00	\$65.95
	11/01/2015	\$42.24	\$10.00	\$14.30	\$0.00	\$66.54
	05/01/2016	\$43.13	\$10.00	\$14.30	\$0.00	\$67.43
	11/01/2016	\$43.73	\$10.00	\$14.30	\$0.00	\$68.03
	05/01/2017	\$44.62	\$10.00	\$14.30	\$0.00	\$68.92
	11/01/2017	\$45.35	\$10.00	\$14.30	\$0.00	\$69.65
	05/01/2018	\$46.07	\$10.00	\$14.30	\$0.00	\$70.37

For apprentice rates see "Apprentice- OPERATING ENGINEERS"

Classification	Effective Date	Base Wage	Health	Pension	Supplemental Unemployment	Total Rate
FIELD ENG.ROD PERSON-BLDG,SITE,HVY/HWY <i>OPERATING ENGINEERS LOCAL 4</i>	05/01/2015	\$21.68	\$10.00	\$14.30	\$0.00	\$45.98
	11/01/2015	\$22.02	\$10.00	\$14.30	\$0.00	\$46.32
	05/01/2016	\$22.54	\$10.00	\$14.30	\$0.00	\$46.84
	11/01/2016	\$22.89	\$10.00	\$14.30	\$0.00	\$47.19
	05/01/2017	\$23.42	\$10.00	\$14.30	\$0.00	\$47.72
	11/01/2017	\$23.84	\$10.00	\$14.30	\$0.00	\$48.14
	05/01/2018	\$24.27	\$10.00	\$14.30	\$0.00	\$48.57
For apprentice rates see "Apprentice- OPERATING ENGINEERS"						
FIRE ALARM INSTALLER <i>ELECTRICIANS LOCAL 103</i>	03/01/2015	\$45.17	\$13.00	\$15.40	\$0.00	\$73.57
	09/01/2015	\$46.13	\$13.00	\$15.43	\$0.00	\$74.56
	03/01/2016	\$47.08	\$13.00	\$15.46	\$0.00	\$75.54
For apprentice rates see "Apprentice- ELECTRICIAN"						
FIRE ALARM REPAIR / MAINTENANCE / COMMISSIONING <i>ELECTRICIANS LOCAL 103</i>	03/01/2015	\$33.88	\$13.00	\$13.70	\$0.00	\$60.58
	09/01/2015	\$34.60	\$13.00	\$13.72	\$0.00	\$61.32
	03/01/2016	\$35.31	\$13.00	\$13.74	\$0.00	\$62.05
For apprentice rates see "Apprentice- TELECOMMUNICATIONS TECHNICIAN"						
FIREMAN (ASST. ENGINEER) <i>OPERATING ENGINEERS LOCAL 4</i>	06/01/2015	\$35.64	\$10.00	\$14.55	\$0.00	\$60.19
	12/01/2015	\$36.69	\$10.00	\$14.55	\$0.00	\$61.24
	06/01/2016	\$37.31	\$10.00	\$14.55	\$0.00	\$61.86
	12/01/2016	\$38.35	\$10.00	\$14.55	\$0.00	\$62.90
	06/01/2017	\$39.19	\$10.00	\$14.55	\$0.00	\$63.74
	12/01/2017	\$40.02	\$10.00	\$14.55	\$0.00	\$64.57
For apprentice rates see "Apprentice- OPERATING ENGINEERS"						
FLAGGER & SIGNALER <i>LABORERS - ZONE 1</i>	06/01/2015	\$20.50	\$7.30	\$12.95	\$0.00	\$40.75
	12/01/2015	\$20.50	\$7.30	\$12.95	\$0.00	\$40.75
	06/01/2016	\$20.50	\$7.30	\$12.95	\$0.00	\$40.75
	12/01/2016	\$20.50	\$7.30	\$12.95	\$0.00	\$40.75
For apprentice rates see "Apprentice- LABORER"						
FLOORCOVERER <i>FLOORCOVERERS LOCAL 2168 ZONE 1</i>	09/01/2014	\$40.40	\$9.80	\$17.21	\$0.00	\$67.41

**Classification**

**Effective Date    Base Wage    Health    Pension    Supplemental Unemployment    Total Rate**

**Apprentice - FLOORCOVERER - Local 2168 Zone 1**

**Effective Date - 09/01/2014**

Step	percent	Apprentice Base Wage	Health	Pension	Supplemental Unemployment	Total Rate
1	50	\$20.20	\$9.80	\$1.79	\$0.00	\$31.79
2	55	\$22.22	\$9.80	\$1.79	\$0.00	\$33.81
3	60	\$24.24	\$9.80	\$11.84	\$0.00	\$45.88
4	65	\$26.26	\$9.80	\$11.84	\$0.00	\$47.90
5	70	\$28.28	\$9.80	\$13.63	\$0.00	\$51.71
6	75	\$30.30	\$9.80	\$13.63	\$0.00	\$53.73
7	80	\$32.32	\$9.80	\$15.42	\$0.00	\$57.54
8	85	\$34.34	\$9.80	\$15.42	\$0.00	\$59.56

**Notes:**

Steps are 750 hrs.

**Apprentice to Journeyworker Ratio:1:1**

<b>FORK LIFT/CHERRY PICKER</b> <i>OPERATING ENGINEERS LOCAL 4</i>	06/01/2015	\$42.83	\$10.00	\$14.55	\$0.00	\$67.38
	12/01/2015	\$44.08	\$10.00	\$14.55	\$0.00	\$68.63
	06/01/2016	\$44.83	\$10.00	\$14.55	\$0.00	\$69.38
	12/01/2016	\$46.08	\$10.00	\$14.55	\$0.00	\$70.63
	06/01/2017	\$47.08	\$10.00	\$14.55	\$0.00	\$71.63
	12/01/2017	\$48.08	\$10.00	\$14.55	\$0.00	\$72.63

For apprentice rates see "Apprentice- OPERATING ENGINEERS"

<b>GENERATOR/LIGHTING PLANT/HEATERS</b> <i>OPERATING ENGINEERS LOCAL 4</i>	06/01/2015	\$29.61	\$10.00	\$14.55	\$0.00	\$54.16
	12/01/2015	\$30.48	\$10.00	\$14.55	\$0.00	\$55.03
	06/01/2016	\$31.00	\$10.00	\$14.55	\$0.00	\$55.55
	12/01/2016	\$31.87	\$10.00	\$14.55	\$0.00	\$56.42
	06/01/2017	\$32.56	\$10.00	\$14.55	\$0.00	\$57.11
	12/01/2017	\$33.25	\$10.00	\$14.55	\$0.00	\$57.80

For apprentice rates see "Apprentice- OPERATING ENGINEERS"

<b>GLAZIER (GLASS PLANK/AIR BARRIER/INTERIOR SYSTEMS)</b> <i>GLAZIERS LOCAL 35 (ZONE 2)</i>	01/01/2015	\$37.16	\$7.85	\$16.10	\$0.00	\$61.11
	07/01/2015	\$38.06	\$7.85	\$16.10	\$0.00	\$62.01
	01/01/2016	\$39.01	\$7.85	\$16.10	\$0.00	\$62.96
	07/01/2016	\$39.96	\$7.85	\$16.10	\$0.00	\$63.91
	01/01/2017	\$40.91	\$7.85	\$16.10	\$0.00	\$64.86

**Apprentice - GLAZIER - Local 35 Zone 2**

**Effective Date - 01/01/2015**

Step	percent	Apprentice Base Wage	Health	Pension	Supplemental Unemployment	Total Rate
1	50	\$18.58	\$7.85	\$0.00	\$0.00	\$26.43
2	55	\$20.44	\$7.85	\$3.66	\$0.00	\$31.95
3	60	\$22.30	\$7.85	\$3.99	\$0.00	\$34.14
4	65	\$24.15	\$7.85	\$4.32	\$0.00	\$36.32
5	70	\$26.01	\$7.85	\$14.11	\$0.00	\$47.97
6	75	\$27.87	\$7.85	\$14.44	\$0.00	\$50.16
7	80	\$29.73	\$7.85	\$14.77	\$0.00	\$52.35
8	90	\$33.44	\$7.85	\$15.44	\$0.00	\$56.73

**Effective Date - 07/01/2015**

Step	percent	Apprentice Base Wage	Health	Pension	Supplemental Unemployment	Total Rate
1	50	\$19.03	\$7.85	\$0.00	\$0.00	\$26.88
2	55	\$20.93	\$7.85	\$3.66	\$0.00	\$32.44
3	60	\$22.84	\$7.85	\$3.99	\$0.00	\$34.68
4	65	\$24.74	\$7.85	\$4.32	\$0.00	\$36.91
5	70	\$26.64	\$7.85	\$14.11	\$0.00	\$48.60
6	75	\$28.55	\$7.85	\$14.44	\$0.00	\$50.84
7	80	\$30.45	\$7.85	\$14.77	\$0.00	\$53.07
8	90	\$34.25	\$7.85	\$15.44	\$0.00	\$57.54

**Notes:**

Steps are 750 hrs.

**Apprentice to Journeyworker Ratio:1:1**

HOISTING ENGINEER/CRANES/GRADALLS	06/01/2015	\$42.83	\$10.00	\$14.55	\$0.00	\$67.38
OPERATING ENGINEERS LOCAL 4	12/01/2015	\$44.08	\$10.00	\$14.55	\$0.00	\$68.63
	06/01/2016	\$44.83	\$10.00	\$14.55	\$0.00	\$69.38
	12/01/2016	\$46.08	\$10.00	\$14.55	\$0.00	\$70.63
	06/01/2017	\$47.08	\$10.00	\$14.55	\$0.00	\$71.63
	12/01/2017	\$48.08	\$10.00	\$14.55	\$0.00	\$72.63

**Classification**

**Effective Date   Base Wage   Health   Pension   Supplemental Unemployment   Total Rate**

**Apprentice - OPERATING ENGINEERS - Local 4**

**Effective Date - 06/01/2015**

Step	percent	Apprentice Base Wage	Health	Pension	Supplemental Unemployment	Total Rate
1	55	\$23.56	\$10.00	\$0.00	\$0.00	\$33.56
2	60	\$25.70	\$10.00	\$14.55	\$0.00	\$50.25
3	65	\$27.84	\$10.00	\$14.55	\$0.00	\$52.39
4	70	\$29.98	\$10.00	\$14.55	\$0.00	\$54.53
5	75	\$32.12	\$10.00	\$14.55	\$0.00	\$56.67
6	80	\$34.26	\$10.00	\$14.55	\$0.00	\$58.81
7	85	\$36.41	\$10.00	\$14.55	\$0.00	\$60.96
8	90	\$38.55	\$10.00	\$14.55	\$0.00	\$63.10

**Effective Date - 12/01/2015**

Step	percent	Apprentice Base Wage	Health	Pension	Supplemental Unemployment	Total Rate
1	55	\$24.24	\$10.00	\$0.00	\$0.00	\$34.24
2	60	\$26.45	\$10.00	\$14.55	\$0.00	\$51.00
3	65	\$28.65	\$10.00	\$14.55	\$0.00	\$53.20
4	70	\$30.86	\$10.00	\$14.55	\$0.00	\$55.41
5	75	\$33.06	\$10.00	\$14.55	\$0.00	\$57.61
6	80	\$35.26	\$10.00	\$14.55	\$0.00	\$59.81
7	85	\$37.47	\$10.00	\$14.55	\$0.00	\$62.02
8	90	\$39.67	\$10.00	\$14.55	\$0.00	\$64.22

**Notes:**

**Apprentice to Journeyworker Ratio:1:6**

HVAC (DUCTWORK) SHEETMETAL WORKERS LOCAL 17 - A	02/01/2015	\$43.28	\$10.20	\$20.54	\$2.22	\$76.24
	08/01/2015	\$44.28	\$10.20	\$20.54	\$2.22	\$77.24
	02/01/2016	\$45.28	\$10.20	\$20.54	\$2.22	\$78.24
	08/01/2016	\$46.43	\$10.20	\$20.54	\$2.22	\$79.39
	02/01/2017	\$47.53	\$10.20	\$20.54	\$2.22	\$80.49
	08/01/2017	\$48.63	\$10.20	\$20.54	\$2.22	\$81.59
	02/01/2018	\$49.78	\$10.20	\$20.54	\$2.22	\$82.74

For apprentice rates see "Apprentice- SHEET METAL WORKER"

HVAC (ELECTRICAL CONTROLS) ELECTRICIANS LOCAL 103	03/01/2015	\$45.17	\$13.00	\$15.40	\$0.00	\$73.57
	09/01/2015	\$46.13	\$13.00	\$15.43	\$0.00	\$74.56
	03/01/2016	\$47.08	\$13.00	\$15.46	\$0.00	\$75.54

For apprentice rates see "Apprentice- ELECTRICIAN"

Classification	Effective Date	Base Wage	Health	Pension	Supplemental Unemployment	Total Rate
HVAC (TESTING AND BALANCING - AIR) <i>SHEETMETAL WORKERS LOCAL 17 - A</i>	02/01/2015	\$43.28	\$10.20	\$20.54	\$2.22	\$76.24
	08/01/2015	\$44.28	\$10.20	\$20.54	\$2.22	\$77.24
	02/01/2016	\$45.28	\$10.20	\$20.54	\$2.22	\$78.24
	08/01/2016	\$46.43	\$10.20	\$20.54	\$2.22	\$79.39
	02/01/2017	\$47.53	\$10.20	\$20.54	\$2.22	\$80.49
	08/01/2017	\$48.63	\$10.20	\$20.54	\$2.22	\$81.59
	02/01/2018	\$49.78	\$10.20	\$20.54	\$2.22	\$82.74
For apprentice rates see "Apprentice- SHEET METAL WORKER"						
HVAC (TESTING AND BALANCING -WATER) <i>PIPEFITTERS LOCAL 537</i>	03/01/2015	\$48.69	\$9.70	\$16.89	\$0.00	\$75.28
	09/01/2015	\$49.69	\$9.70	\$16.89	\$0.00	\$76.28
	03/01/2016	\$50.69	\$9.70	\$16.89	\$0.00	\$77.28
	09/01/2016	\$51.69	\$9.70	\$16.89	\$0.00	\$78.28
	03/01/2017	\$52.69	\$9.70	\$16.89	\$0.00	\$79.28
For apprentice rates see "Apprentice- PIPEFITTER" or "PLUMBER/PIPEFITTER"						
HVAC MECHANIC <i>PIPEFITTERS LOCAL 537</i>	03/01/2015	\$48.69	\$9.70	\$16.89	\$0.00	\$75.28
	09/01/2015	\$49.69	\$9.70	\$16.89	\$0.00	\$76.28
	03/01/2016	\$50.69	\$9.70	\$16.89	\$0.00	\$77.28
	09/01/2016	\$51.69	\$9.70	\$16.89	\$0.00	\$78.28
	03/01/2017	\$52.69	\$9.70	\$16.89	\$0.00	\$79.28
For apprentice rates see "Apprentice- PIPEFITTER" or "PLUMBER/PIPEFITTER"						
HYDRAULIC DRILLS <i>LABORERS - ZONE 1</i>	06/01/2015	\$36.10	\$7.30	\$12.95	\$0.00	\$56.35
	12/01/2015	\$36.85	\$7.30	\$12.95	\$0.00	\$57.10
	06/01/2016	\$37.60	\$7.30	\$12.95	\$0.00	\$57.85
	12/01/2016	\$38.60	\$7.30	\$12.95	\$0.00	\$58.85
For apprentice rates see "Apprentice- LABORER"						
INSULATOR (PIPES & TANKS) <i>HEAT &amp; FROST INSULATORS LOCAL 6 (BOSTON)</i>	09/01/2014	\$43.31	\$11.25	\$12.60	\$0.00	\$67.16

**Apprentice - ASBESTOS INSULATOR (Pipes & Tanks) - Local 6 Boston**

**Effective Date - 09/01/2014**

Step	percent	Apprentice Base Wage	Health	Pension	Supplemental Unemployment	Total Rate
1	50	\$21.66	\$11.25	\$9.35	\$0.00	\$42.26
2	60	\$25.99	\$11.25	\$10.00	\$0.00	\$47.24
3	70	\$30.32	\$11.25	\$10.65	\$0.00	\$52.22
4	80	\$34.65	\$11.25	\$11.30	\$0.00	\$57.20

**Notes:**

Steps are 1 year

**Apprentice to Journeyworker Ratio:1:4**

IRONWORKER/WELDER <i>IRONWORKERS LOCAL 7 (BOSTON AREA)</i>	03/16/2015	\$42.11	\$7.70	\$20.25	\$0.00	\$70.06
---	------------	---------	--------	---------	--------	---------

**Classification**

**Effective Date   Base Wage   Health   Pension   Supplemental Unemployment   Total Rate**

**Apprentice - IRONWORKER - Local 7 Boston**

**Effective Date - 03/16/2015**

Step	percent	Apprentice Base Wage	Health	Pension	Supplemental Unemployment	Total Rate
1	60	\$25.27	\$7.70	\$20.25	\$0.00	\$53.22
2	70	\$29.48	\$7.70	\$20.25	\$0.00	\$57.43
3	75	\$31.58	\$7.70	\$20.25	\$0.00	\$59.53
4	80	\$33.69	\$7.70	\$20.25	\$0.00	\$61.64
5	85	\$35.79	\$7.70	\$20.25	\$0.00	\$63.74
6	90	\$37.90	\$7.70	\$20.25	\$0.00	\$65.85

**Notes:**

\*\* Structural 1:6; Ornamental 1:4

**Apprentice to Journeyworker Ratio:\*\***

JACKHAMMER & PAVING BREAKER OPERATOR LABORERS - ZONE 1	06/01/2015	\$35.60	\$7.30	\$12.95	\$0.00	\$55.85
	12/01/2015	\$36.35	\$7.30	\$12.95	\$0.00	\$56.60
	06/01/2016	\$37.10	\$7.30	\$12.95	\$0.00	\$57.35
	12/01/2016	\$38.10	\$7.30	\$12.95	\$0.00	\$58.35

For apprentice rates see "Apprentice- LABORER"

LABORER LABORERS - ZONE 1	06/01/2015	\$35.35	\$7.30	\$12.95	\$0.00	\$55.60
	12/01/2015	\$36.10	\$7.30	\$12.95	\$0.00	\$56.35
	06/01/2016	\$36.85	\$7.30	\$12.95	\$0.00	\$57.10
	12/01/2016	\$37.85	\$7.30	\$12.95	\$0.00	\$58.10

**Apprentice - LABORER - Zone 1**

**Effective Date - 06/01/2015**

Step	percent	Apprentice Base Wage	Health	Pension	Supplemental Unemployment	Total Rate
1	60	\$21.21	\$7.30	\$12.95	\$0.00	\$41.46
2	70	\$24.75	\$7.30	\$12.95	\$0.00	\$45.00
3	80	\$28.28	\$7.30	\$12.95	\$0.00	\$48.53
4	90	\$31.82	\$7.30	\$12.95	\$0.00	\$52.07

**Effective Date - 12/01/2015**

Step	percent	Apprentice Base Wage	Health	Pension	Supplemental Unemployment	Total Rate
1	60	\$21.66	\$7.30	\$12.95	\$0.00	\$41.91
2	70	\$25.27	\$7.30	\$12.95	\$0.00	\$45.52
3	80	\$28.88	\$7.30	\$12.95	\$0.00	\$49.13
4	90	\$32.49	\$7.30	\$12.95	\$0.00	\$52.74

**Notes:**

**Apprentice to Journeyworker Ratio:1:5**

<b>Classification</b>	<b>Effective Date</b>	<b>Base Wage</b>	<b>Health</b>	<b>Pension</b>	<b>Supplemental Unemployment</b>	<b>Total Rate</b>
LABORER: CARPENTER TENDER <i>LABORERS - ZONE 1</i>	06/01/2015	\$35.35	\$7.30	\$12.95	\$0.00	\$55.60
	12/01/2015	\$36.10	\$7.30	\$12.95	\$0.00	\$56.35
	06/01/2016	\$36.85	\$7.30	\$12.95	\$0.00	\$57.10
	12/01/2016	\$37.85	\$7.30	\$12.95	\$0.00	\$58.10
For apprentice rates see "Apprentice- LABORER"						
LABORER: CEMENT FINISHER TENDER <i>LABORERS - ZONE 1</i>	06/01/2015	\$35.35	\$7.30	\$12.95	\$0.00	\$55.60
	12/01/2015	\$36.10	\$7.30	\$12.95	\$0.00	\$56.35
	06/01/2016	\$36.85	\$7.30	\$12.95	\$0.00	\$57.10
	12/01/2016	\$37.85	\$7.30	\$12.95	\$0.00	\$58.10
For apprentice rates see "Apprentice- LABORER"						
LABORER: HAZARDOUS WASTE/ASBESTOS REMOVER <i>LABORERS - ZONE 1</i>	06/01/2015	\$35.50	\$7.30	\$12.95	\$0.00	\$55.75
	12/01/2015	\$36.25	\$7.30	\$12.95	\$0.00	\$56.50
For apprentice rates see "Apprentice- LABORER"						
LABORER: MASON TENDER <i>LABORERS - ZONE 1</i>	06/01/2015	\$35.60	\$7.30	\$12.95	\$0.00	\$55.85
	12/01/2015	\$36.35	\$7.30	\$12.95	\$0.00	\$56.60
	06/01/2016	\$37.10	\$7.30	\$12.95	\$0.00	\$57.35
	12/01/2016	\$38.10	\$7.30	\$12.95	\$0.00	\$58.35
For apprentice rates see "Apprentice- LABORER"						
LABORER: MULTI-TRADE TENDER <i>LABORERS - ZONE 1</i>	06/01/2015	\$35.35	\$7.30	\$12.95	\$0.00	\$55.60
	12/01/2015	\$36.10	\$7.30	\$12.95	\$0.00	\$56.35
	06/01/2016	\$36.85	\$7.30	\$12.95	\$0.00	\$57.10
	12/01/2016	\$37.85	\$7.30	\$12.95	\$0.00	\$58.10
For apprentice rates see "Apprentice- LABORER"						
LABORER: TREE REMOVER <i>LABORERS - ZONE 1</i>	06/01/2015	\$35.35	\$7.30	\$12.95	\$0.00	\$55.60
	12/01/2015	\$36.10	\$7.30	\$12.95	\$0.00	\$56.35
	06/01/2016	\$36.85	\$7.30	\$12.95	\$0.00	\$57.10
	12/01/2016	\$37.85	\$7.30	\$12.95	\$0.00	\$58.10
This classification applies to all tree work associated with the removal of standing trees, and trimming and removal of branches and limbs when the work is not done for a utility company for the purpose of operation, maintenance or repair of utility company equipment. For apprentice rates see "Apprentice- LABORER"						
LASER BEAM OPERATOR <i>LABORERS - ZONE 1</i>	06/01/2015	\$35.60	\$7.30	\$12.95	\$0.00	\$55.85
	12/01/2015	\$36.35	\$7.30	\$12.95	\$0.00	\$56.60
	06/01/2016	\$37.10	\$7.30	\$12.95	\$0.00	\$57.35
	12/01/2016	\$38.10	\$7.30	\$12.95	\$0.00	\$58.35
For apprentice rates see "Apprentice- LABORER"						
MARBLE & TILE FINISHERS <i>BRICKLAYERS LOCAL 3 - MARBLE &amp; TILE</i>	02/01/2015	\$37.37	\$10.18	\$17.18	\$0.00	\$64.73
	08/01/2015	\$38.08	\$10.18	\$17.25	\$0.00	\$65.51
	02/01/2016	\$38.53	\$10.18	\$17.25	\$0.00	\$65.96
	08/01/2016	\$39.23	\$10.18	\$17.33	\$0.00	\$66.74
	02/01/2017	\$39.69	\$10.18	\$17.33	\$0.00	\$67.20



**Classification**

**Effective Date    Base Wage    Health    Pension    Supplemental Unemployment    Total Rate**

**Apprentice - MARBLE & TILE FINISHER - Local 3 Marble & Tile**

**Effective Date - 02/01/2015**

Step	percent	Apprentice Base Wage	Health	Pension	Supplemental Unemployment	Total Rate
1	50	\$18.69	\$10.18	\$17.18	\$0.00	\$46.05
2	60	\$22.42	\$10.18	\$17.18	\$0.00	\$49.78
3	70	\$26.16	\$10.18	\$17.18	\$0.00	\$53.52
4	80	\$29.90	\$10.18	\$17.18	\$0.00	\$57.26
5	90	\$33.63	\$10.18	\$17.18	\$0.00	\$60.99

**Effective Date - 08/01/2015**

Step	percent	Apprentice Base Wage	Health	Pension	Supplemental Unemployment	Total Rate
1	50	\$19.04	\$10.18	\$17.25	\$0.00	\$46.47
2	60	\$22.85	\$10.18	\$17.25	\$0.00	\$50.28
3	70	\$26.66	\$10.18	\$17.25	\$0.00	\$54.09
4	80	\$30.46	\$10.18	\$17.25	\$0.00	\$57.89
5	90	\$34.27	\$10.18	\$17.25	\$0.00	\$61.70

**Notes:**

---

**Apprentice to Journeyworker Ratio:1:3**

MARBLE MASONS, TILELAYERS & TERRAZZO MECH	02/01/2015	\$49.00	\$10.18	\$18.50	\$0.00	\$77.68
BRICKLAYERS LOCAL 3 - MARBLE & TILE	08/01/2015	\$49.90	\$10.18	\$18.57	\$0.00	\$78.65
	02/01/2016	\$50.47	\$10.18	\$18.57	\$0.00	\$79.22
	08/01/2016	\$51.37	\$10.18	\$18.65	\$0.00	\$80.20
	02/01/2017	\$51.94	\$10.18	\$18.65	\$0.00	\$80.77

**Classification**

**Effective Date   Base Wage   Health   Pension   Supplemental Unemployment   Total Rate**

**Apprentice - MARBLE-TILE-TERRAZZO MECHANIC - Local 3 Marble & Tile**

**Effective Date - 02/01/2015**

Step	percent	Apprentice Base Wage	Health	Pension	Supplemental Unemployment	Total Rate
1	50	\$24.50	\$10.18	\$18.50	\$0.00	\$53.18
2	60	\$29.40	\$10.18	\$18.50	\$0.00	\$58.08
3	70	\$34.30	\$10.18	\$18.50	\$0.00	\$62.98
4	80	\$39.20	\$10.18	\$18.50	\$0.00	\$67.88
5	90	\$44.10	\$10.18	\$18.50	\$0.00	\$72.78

**Effective Date - 08/01/2015**

Step	percent	Apprentice Base Wage	Health	Pension	Supplemental Unemployment	Total Rate
1	50	\$24.95	\$10.18	\$18.57	\$0.00	\$53.70
2	60	\$29.94	\$10.18	\$18.57	\$0.00	\$58.69
3	70	\$34.93	\$10.18	\$18.57	\$0.00	\$63.68
4	80	\$39.92	\$10.18	\$18.57	\$0.00	\$68.67
5	90	\$44.91	\$10.18	\$18.57	\$0.00	\$73.66

**Notes:**

---

**Apprentice to Journeyworker Ratio:1:5**

MECH. SWEEPER OPERATOR (ON CONST. SITES) <i>OPERATING ENGINEERS LOCAL 4</i>	06/01/2015	\$42.42	\$10.00	\$14.55	\$0.00	\$66.97
	12/01/2015	\$43.66	\$10.00	\$14.55	\$0.00	\$68.21
	06/01/2016	\$44.41	\$10.00	\$14.55	\$0.00	\$68.96
	12/01/2016	\$45.64	\$10.00	\$14.55	\$0.00	\$70.19
	06/01/2017	\$46.63	\$10.00	\$14.55	\$0.00	\$71.18
	12/01/2017	\$47.62	\$10.00	\$14.55	\$0.00	\$72.17
For apprentice rates see "Apprentice- OPERATING ENGINEERS"						
MECHANICS MAINTENANCE <i>OPERATING ENGINEERS LOCAL 4</i>	06/01/2015	\$42.42	\$10.00	\$14.55	\$0.00	\$66.97
	12/01/2015	\$43.66	\$10.00	\$14.55	\$0.00	\$68.21
	06/01/2016	\$44.41	\$10.00	\$14.55	\$0.00	\$68.96
	12/01/2016	\$45.64	\$10.00	\$14.55	\$0.00	\$70.19
	06/01/2017	\$46.63	\$10.00	\$14.55	\$0.00	\$71.18
	12/01/2017	\$47.62	\$10.00	\$14.55	\$0.00	\$72.17
For apprentice rates see "Apprentice- OPERATING ENGINEERS"						
MILLWRIGHT (Zone 1) <i>MILLWRIGHTS LOCAL 1121 - Zone 1</i>	04/01/2015	\$37.64	\$9.80	\$16.21	\$0.00	\$63.65

**Apprentice - MILLWRIGHT - Local 1121 Zone 1**

**Effective Date - 04/01/2015**

Step	percent	Apprentice Base Wage	Health	Pension	Supplemental Unemployment	Total Rate
1	55	\$20.70	\$9.80	\$4.48	\$0.00	\$34.98
2	65	\$24.47	\$9.80	\$13.36	\$0.00	\$47.63
3	75	\$28.23	\$9.80	\$14.18	\$0.00	\$52.21
4	85	\$31.99	\$9.80	\$14.99	\$0.00	\$56.78

**Notes:**

Steps are 2,000 hours

**Apprentice to Journeyworker Ratio:1:5**

<b>MORTAR MIXER</b> <i>LABORERS - ZONE 1</i>	06/01/2015	\$35.60	\$7.30	\$12.95	\$0.00	\$55.85
	12/01/2015	\$36.35	\$7.30	\$12.95	\$0.00	\$56.60
	06/01/2016	\$37.10	\$7.30	\$12.95	\$0.00	\$57.35
	12/01/2016	\$38.10	\$7.30	\$12.95	\$0.00	\$58.35

For apprentice rates see "Apprentice- LABORER"

<b>OILER (OTHER THAN TRUCK CRANES,GRADALLS)</b> <i>OPERATING ENGINEERS LOCAL 4</i>	06/01/2015	\$21.97	\$10.00	\$14.55	\$0.00	\$46.52
	12/01/2015	\$22.62	\$10.00	\$14.55	\$0.00	\$47.17
	06/01/2016	\$23.01	\$10.00	\$14.55	\$0.00	\$47.56
	12/01/2016	\$23.66	\$10.00	\$14.55	\$0.00	\$48.21
	06/01/2017	\$24.17	\$10.00	\$14.55	\$0.00	\$48.72
	12/01/2017	\$24.69	\$10.00	\$14.55	\$0.00	\$49.24

For apprentice rates see "Apprentice- OPERATING ENGINEERS"

<b>OILER (TRUCK CRANES, GRADALLS)</b> <i>OPERATING ENGINEERS LOCAL 4</i>	06/01/2015	\$25.68	\$10.00	\$14.55	\$0.00	\$50.23
	12/01/2015	\$26.43	\$10.00	\$14.55	\$0.00	\$50.98
	06/01/2016	\$26.89	\$10.00	\$14.55	\$0.00	\$51.44
	12/01/2016	\$27.64	\$10.00	\$14.55	\$0.00	\$52.19
	06/01/2017	\$28.24	\$10.00	\$14.55	\$0.00	\$52.79
	12/01/2017	\$28.85	\$10.00	\$14.55	\$0.00	\$53.40

For apprentice rates see "Apprentice- OPERATING ENGINEERS"

<b>OTHER POWER DRIVEN EQUIPMENT - CLASS II</b> <i>OPERATING ENGINEERS LOCAL 4</i>	06/01/2015	\$42.42	\$10.00	\$14.55	\$0.00	\$66.97
	12/01/2015	\$43.66	\$10.00	\$14.55	\$0.00	\$68.21
	06/01/2016	\$44.41	\$10.00	\$14.55	\$0.00	\$68.96
	12/01/2016	\$45.64	\$10.00	\$14.55	\$0.00	\$70.19
	06/01/2017	\$46.63	\$10.00	\$14.55	\$0.00	\$71.18
	12/01/2017	\$47.62	\$10.00	\$14.55	\$0.00	\$72.17

For apprentice rates see "Apprentice- OPERATING ENGINEERS"

<b>PAINTER (BRIDGES/TANKS)</b> <i>PAINTERS LOCAL 35 - ZONE 2</i>	01/01/2015	\$47.66	\$7.85	\$16.10	\$0.00	\$71.61
	07/01/2015	\$48.56	\$7.85	\$16.10	\$0.00	\$72.51
	01/01/2016	\$49.51	\$7.85	\$16.10	\$0.00	\$73.46
	07/01/2016	\$50.46	\$7.85	\$16.10	\$0.00	\$74.41
	01/01/2017	\$51.41	\$7.85	\$16.10	\$0.00	\$75.36

**Apprentice - PAINTER Local 35 - BRIDGES/TANKS**

**Effective Date - 01/01/2015**

Step	percent	Apprentice Base Wage	Health	Pension	Supplemental Unemployment	Total Rate
1	50	\$23.83	\$7.85	\$0.00	\$0.00	\$31.68
2	55	\$26.21	\$7.85	\$3.66	\$0.00	\$37.72
3	60	\$28.60	\$7.85	\$3.99	\$0.00	\$40.44
4	65	\$30.98	\$7.85	\$4.32	\$0.00	\$43.15
5	70	\$33.36	\$7.85	\$14.11	\$0.00	\$55.32
6	75	\$35.75	\$7.85	\$14.44	\$0.00	\$58.04
7	80	\$38.13	\$7.85	\$14.77	\$0.00	\$60.75
8	90	\$42.89	\$7.85	\$15.44	\$0.00	\$66.18

**Effective Date - 07/01/2015**

Step	percent	Apprentice Base Wage	Health	Pension	Supplemental Unemployment	Total Rate
1	50	\$24.28	\$7.85	\$0.00	\$0.00	\$32.13
2	55	\$26.71	\$7.85	\$3.66	\$0.00	\$38.22
3	60	\$29.14	\$7.85	\$3.99	\$0.00	\$40.98
4	65	\$31.56	\$7.85	\$4.32	\$0.00	\$43.73
5	70	\$33.99	\$7.85	\$14.11	\$0.00	\$55.95
6	75	\$36.42	\$7.85	\$14.44	\$0.00	\$58.71
7	80	\$38.85	\$7.85	\$14.77	\$0.00	\$61.47
8	90	\$43.70	\$7.85	\$15.44	\$0.00	\$66.99

**Notes:**

Steps are 750 hrs.

**Apprentice to Journeyworker Ratio:1:1**

PAINTER (SPRAY OR SANDBLAST, NEW) *	01/01/2015	\$38.56	\$7.85	\$16.10	\$0.00	\$62.51
* If 30% or more of surfaces to be painted are new construction, NEW paint rate shall be used. PAINTERS LOCAL 35 - ZONE 2	07/01/2015	\$39.46	\$7.85	\$16.10	\$0.00	\$63.41
	01/01/2016	\$40.41	\$7.85	\$16.10	\$0.00	\$64.36
	07/01/2016	\$41.36	\$7.85	\$16.10	\$0.00	\$65.31
	01/01/2017	\$42.31	\$7.85	\$16.10	\$0.00	\$66.26

**Apprentice - PAINTER Local 35 Zone 2 - Spray/Sandblast - New**

**Effective Date - 01/01/2015**

Step	percent	Apprentice Base Wage	Health	Pension	Supplemental Unemployment	Total Rate
1	50	\$19.28	\$7.85	\$0.00	\$0.00	\$27.13
2	55	\$21.21	\$7.85	\$3.66	\$0.00	\$32.72
3	60	\$23.14	\$7.85	\$3.99	\$0.00	\$34.98
4	65	\$25.06	\$7.85	\$4.32	\$0.00	\$37.23
5	70	\$26.99	\$7.85	\$14.11	\$0.00	\$48.95
6	75	\$28.92	\$7.85	\$14.44	\$0.00	\$51.21
7	80	\$30.85	\$7.85	\$14.77	\$0.00	\$53.47
8	90	\$34.70	\$7.85	\$15.44	\$0.00	\$57.99

**Effective Date - 07/01/2015**

Step	percent	Apprentice Base Wage	Health	Pension	Supplemental Unemployment	Total Rate
1	50	\$19.73	\$7.85	\$0.00	\$0.00	\$27.58
2	55	\$21.70	\$7.85	\$3.66	\$0.00	\$33.21
3	60	\$23.68	\$7.85	\$3.99	\$0.00	\$35.52
4	65	\$25.65	\$7.85	\$4.32	\$0.00	\$37.82
5	70	\$27.62	\$7.85	\$14.11	\$0.00	\$49.58
6	75	\$29.60	\$7.85	\$14.44	\$0.00	\$51.89
7	80	\$31.57	\$7.85	\$14.77	\$0.00	\$54.19
8	90	\$35.51	\$7.85	\$15.44	\$0.00	\$58.80

**Notes:**

Steps are 750 hrs.

**Apprentice to Journeyworker Ratio:1:1**

PAINTER (SPRAY OR SANDBLAST, REPAINT)	01/01/2015	\$36.62	\$7.85	\$16.10	\$0.00	\$60.57
PAINTERS LOCAL 35 - ZONE 2	07/01/2015	\$37.52	\$7.85	\$16.10	\$0.00	\$61.47
	01/01/2016	\$38.47	\$7.85	\$16.10	\$0.00	\$62.42
	07/01/2016	\$39.42	\$7.85	\$16.10	\$0.00	\$63.37
	01/01/2017	\$40.37	\$7.85	\$16.10	\$0.00	\$64.32

**Classification**

**Effective Date   Base Wage   Health   Pension   Supplemental Unemployment   Total Rate**

**Apprentice - PAINTER Local 35 Zone 2 - Spray/Sandblast - Repaint**

**Effective Date - 01/01/2015**

Step	percent	Apprentice Base Wage	Health	Pension	Supplemental Unemployment	Total Rate
1	50	\$18.31	\$7.85	\$0.00	\$0.00	\$26.16
2	55	\$20.14	\$7.85	\$3.66	\$0.00	\$31.65
3	60	\$21.97	\$7.85	\$3.99	\$0.00	\$33.81
4	65	\$23.80	\$7.85	\$4.32	\$0.00	\$35.97
5	70	\$25.63	\$7.85	\$14.11	\$0.00	\$47.59
6	75	\$27.47	\$7.85	\$14.44	\$0.00	\$49.76
7	80	\$29.30	\$7.85	\$14.77	\$0.00	\$51.92
8	90	\$32.96	\$7.85	\$15.44	\$0.00	\$56.25

**Effective Date - 07/01/2015**

Step	percent	Apprentice Base Wage	Health	Pension	Supplemental Unemployment	Total Rate
1	50	\$18.76	\$7.85	\$0.00	\$0.00	\$26.61
2	55	\$20.64	\$7.85	\$3.66	\$0.00	\$32.15
3	60	\$22.51	\$7.85	\$3.99	\$0.00	\$34.35
4	65	\$24.39	\$7.85	\$4.32	\$0.00	\$36.56
5	70	\$26.26	\$7.85	\$14.11	\$0.00	\$48.22
6	75	\$28.14	\$7.85	\$14.44	\$0.00	\$50.43
7	80	\$30.02	\$7.85	\$14.77	\$0.00	\$52.64
8	90	\$33.77	\$7.85	\$15.44	\$0.00	\$57.06

**Notes:**

Steps are 750 hrs.

**Apprentice to Journeyworker Ratio:1:1**

PAINTER (TRAFFIC MARKINGS) LABORERS - ZONE 1	06/01/2015	\$35.35	\$7.30	\$12.95	\$0.00	\$55.60
	12/01/2015	\$36.10	\$7.30	\$12.95	\$0.00	\$56.35
	06/01/2016	\$36.85	\$7.30	\$12.95	\$0.00	\$57.10
	12/01/2016	\$37.85	\$7.30	\$12.95	\$0.00	\$58.10

For Apprentice rates see "Apprentice- LABORER"

PAINTER / TAPER (BRUSH, NEW) *	01/01/2015	\$37.16	\$7.85	\$16.10	\$0.00	\$61.11
* If 30% or more of surfaces to be painted are new construction, NEW paint rate shall be used. PAINTERS LOCAL 35 - ZONE 2	07/01/2015	\$38.06	\$7.85	\$16.10	\$0.00	\$62.01
	01/01/2016	\$39.01	\$7.85	\$16.10	\$0.00	\$62.96
	07/01/2016	\$39.96	\$7.85	\$16.10	\$0.00	\$63.91
	01/01/2017	\$40.91	\$7.85	\$16.10	\$0.00	\$64.86

**Apprentice - PAINTER - Local 35 Zone 2 - BRUSH NEW**

**Effective Date - 01/01/2015**

Step	percent	Apprentice Base Wage	Health	Pension	Supplemental Unemployment	Total Rate
1	50	\$18.58	\$7.85	\$0.00	\$0.00	\$26.43
2	55	\$20.44	\$7.85	\$3.66	\$0.00	\$31.95
3	60	\$22.30	\$7.85	\$3.99	\$0.00	\$34.14
4	65	\$24.15	\$7.85	\$4.32	\$0.00	\$36.32
5	70	\$26.01	\$7.85	\$14.11	\$0.00	\$47.97
6	75	\$27.87	\$7.85	\$14.44	\$0.00	\$50.16
7	80	\$29.73	\$7.85	\$14.77	\$0.00	\$52.35
8	90	\$33.44	\$7.85	\$15.44	\$0.00	\$56.73

**Effective Date - 07/01/2015**

Step	percent	Apprentice Base Wage	Health	Pension	Supplemental Unemployment	Total Rate
1	50	\$19.03	\$7.85	\$0.00	\$0.00	\$26.88
2	55	\$20.93	\$7.85	\$3.66	\$0.00	\$32.44
3	60	\$22.84	\$7.85	\$3.99	\$0.00	\$34.68
4	65	\$24.74	\$7.85	\$4.32	\$0.00	\$36.91
5	70	\$26.64	\$7.85	\$14.11	\$0.00	\$48.60
6	75	\$28.55	\$7.85	\$14.44	\$0.00	\$50.84
7	80	\$30.45	\$7.85	\$14.77	\$0.00	\$53.07
8	90	\$34.25	\$7.85	\$15.44	\$0.00	\$57.54

**Notes:**  
Steps are 750 hrs.

**Apprentice to Journeyworker Ratio:1:1**

PAINTER / TAPER (BRUSH, REPAINT)	01/01/2015	\$35.22	\$7.85	\$16.10	\$0.00	\$59.17
PAINTERS LOCAL 35 - ZONE 2	07/01/2015	\$36.12	\$7.85	\$16.10	\$0.00	\$60.07
	01/01/2016	\$37.07	\$7.85	\$16.10	\$0.00	\$61.02
	07/01/2016	\$38.02	\$7.85	\$16.10	\$0.00	\$61.97
	01/01/2017	\$38.97	\$7.85	\$16.10	\$0.00	\$62.92

**Classification**

**Effective Date    Base Wage    Health    Pension    Supplemental Unemployment    Total Rate**

**Apprentice - PAINTER Local 35 Zone 2 - BRUSH REPAINT**

**Effective Date - 01/01/2015**

Step	percent	Apprentice Base Wage	Health	Pension	Supplemental Unemployment	Total Rate
1	50	\$17.61	\$7.85	\$0.00	\$0.00	\$25.46
2	55	\$19.37	\$7.85	\$3.66	\$0.00	\$30.88
3	60	\$21.13	\$7.85	\$3.99	\$0.00	\$32.97
4	65	\$22.89	\$7.85	\$4.32	\$0.00	\$35.06
5	70	\$24.65	\$7.85	\$14.11	\$0.00	\$46.61
6	75	\$26.42	\$7.85	\$14.44	\$0.00	\$48.71
7	80	\$28.18	\$7.85	\$14.77	\$0.00	\$50.80
8	90	\$31.70	\$7.85	\$15.44	\$0.00	\$54.99

**Effective Date - 07/01/2015**

Step	percent	Apprentice Base Wage	Health	Pension	Supplemental Unemployment	Total Rate
1	50	\$18.06	\$7.85	\$0.00	\$0.00	\$25.91
2	55	\$19.87	\$7.85	\$3.66	\$0.00	\$31.38
3	60	\$21.67	\$7.85	\$3.99	\$0.00	\$33.51
4	65	\$23.48	\$7.85	\$4.32	\$0.00	\$35.65
5	70	\$25.28	\$7.85	\$14.11	\$0.00	\$47.24
6	75	\$27.09	\$7.85	\$14.44	\$0.00	\$49.38
7	80	\$28.90	\$7.85	\$14.77	\$0.00	\$51.52
8	90	\$32.51	\$7.85	\$15.44	\$0.00	\$55.80

**Notes:**  
Steps are 750 hrs.

**Apprentice to Journeyworker Ratio:1:1**

PANEL & PICKUP TRUCKS DRIVER <i>TEAMSTERS JOINT COUNCIL NO. 10 ZONE A</i>	06/01/2015	\$32.58	\$9.91	\$9.33	\$0.00	\$51.82
	08/01/2015	\$32.58	\$10.41	\$9.33	\$0.00	\$52.32
	12/01/2015	\$32.58	\$10.41	\$10.08	\$0.00	\$53.07
	06/01/2016	\$33.08	\$10.41	\$10.08	\$0.00	\$53.57
	08/01/2016	\$33.08	\$10.91	\$10.08	\$0.00	\$54.07
	12/01/2016	\$33.08	\$10.91	\$10.89	\$0.00	\$54.88
PIER AND DOCK CONSTRUCTOR (UNDERPINNING AND DECK) <i>PILE DRIVER LOCAL 56 (ZONE 1)</i>	08/01/2014	\$41.60	\$9.80	\$18.17	\$0.00	\$69.57
	08/01/2015	\$43.10	\$9.80	\$18.17	\$0.00	\$71.07
PILE DRIVER <i>PILE DRIVER LOCAL 56 (ZONE 1)</i>	08/01/2014	\$41.60	\$9.80	\$18.17	\$0.00	\$69.57
	08/01/2015	\$43.10	\$9.80	\$18.17	\$0.00	\$71.07



**Apprentice - PILE DRIVER - Local 56 Zone 1**

**Effective Date - 08/01/2014**

Step	percent	Apprentice Base Wage	Health	Pension	Supplemental Unemployment	Total Rate
1	50	\$20.80	\$9.80	\$18.17	\$0.00	\$48.77
2	60	\$24.96	\$9.80	\$18.17	\$0.00	\$52.93
3	70	\$29.12	\$9.80	\$18.17	\$0.00	\$57.09
4	75	\$31.20	\$9.80	\$18.17	\$0.00	\$59.17
5	80	\$33.28	\$9.80	\$18.17	\$0.00	\$61.25
6	80	\$33.28	\$9.80	\$18.17	\$0.00	\$61.25
7	90	\$37.44	\$9.80	\$18.17	\$0.00	\$65.41
8	90	\$37.44	\$9.80	\$18.17	\$0.00	\$65.41

**Effective Date - 08/01/2015**

Step	percent	Apprentice Base Wage	Health	Pension	Supplemental Unemployment	Total Rate
1	50	\$21.55	\$9.80	\$18.17	\$0.00	\$49.52
2	60	\$25.86	\$9.80	\$18.17	\$0.00	\$53.83
3	70	\$30.17	\$9.80	\$18.17	\$0.00	\$58.14
4	75	\$32.33	\$9.80	\$18.17	\$0.00	\$60.30
5	80	\$34.48	\$9.80	\$18.17	\$0.00	\$62.45
6	80	\$34.48	\$9.80	\$18.17	\$0.00	\$62.45
7	90	\$38.79	\$9.80	\$18.17	\$0.00	\$66.76
8	90	\$38.79	\$9.80	\$18.17	\$0.00	\$66.76

**Notes:**

**Apprentice to Journeyworker Ratio:1:3**

PIPEFITTER & STEAMFITTER	03/01/2015	\$48.69	\$9.70	\$16.89	\$0.00	\$75.28
PIPEFITTERS LOCAL 537	09/01/2015	\$49.69	\$9.70	\$16.89	\$0.00	\$76.28
	03/01/2016	\$50.69	\$9.70	\$16.89	\$0.00	\$77.28
	09/01/2016	\$51.69	\$9.70	\$16.89	\$0.00	\$78.28
	03/01/2017	\$52.69	\$9.70	\$16.89	\$0.00	\$79.28

**Classification**

**Effective Date   Base Wage   Health   Pension   Supplemental Unemployment   Total Rate**

**Apprentice - PIPEFITTER - Local 537**

**Effective Date - 03/01/2015**

Step	percent	Apprentice Base Wage	Health	Pension	Supplemental Unemployment	Total Rate
1	40	\$19.48	\$9.70	\$7.50	\$0.00	\$36.68
2	45	\$21.91	\$9.70	\$16.89	\$0.00	\$48.50
3	60	\$29.21	\$9.70	\$16.89	\$0.00	\$55.80
4	70	\$34.08	\$9.70	\$16.89	\$0.00	\$60.67
5	80	\$38.95	\$9.70	\$16.89	\$0.00	\$65.54

**Effective Date - 09/01/2015**

Step	percent	Apprentice Base Wage	Health	Pension	Supplemental Unemployment	Total Rate
1	40	\$19.88	\$9.70	\$7.50	\$0.00	\$37.08
2	45	\$22.36	\$9.70	\$16.89	\$0.00	\$48.95
3	60	\$29.81	\$9.70	\$16.89	\$0.00	\$56.40
4	70	\$34.78	\$9.70	\$16.89	\$0.00	\$61.37
5	80	\$39.75	\$9.70	\$16.89	\$0.00	\$66.34

**Notes:**

\*\* 1:3; 3:15; 1:10 thereafter / Steps are 1 yr.  
 Refrig/AC Mechanic \*\*1:1;1:2;2:4;3:6;4:8;5:10;6:12;7:14;8:17;9:20;10:23(Max)

**Apprentice to Journeyworker Ratio:\*\***

PIPELAYER	06/01/2015	\$35.60	\$7.30	\$12.95	\$0.00	\$55.85
LABORERS - ZONE 1	12/01/2015	\$36.35	\$7.30	\$12.95	\$0.00	\$56.60
	06/01/2016	\$37.10	\$7.30	\$12.95	\$0.00	\$57.35
	12/01/2016	\$38.10	\$7.30	\$12.95	\$0.00	\$58.35

For apprentice rates see "Apprentice- LABORER"

PLUMBERS & GASFITTERS	03/01/2015	\$50.21	\$10.32	\$14.89	\$0.00	\$75.42
PLUMBERS & GASFITTERS LOCAL 12	09/01/2015	\$51.21	\$10.32	\$14.89	\$0.00	\$76.42
	03/01/2016	\$52.36	\$10.32	\$14.89	\$0.00	\$77.57
	09/01/2016	\$53.41	\$10.32	\$14.89	\$0.00	\$78.62
	03/01/2017	\$54.41	\$10.32	\$14.89	\$0.00	\$79.62

**Classification**

**Effective Date   Base Wage   Health   Pension   Supplemental Unemployment   Total Rate**

**Apprentice - PLUMBER/GASFITTER - Local 12**

**Effective Date - 03/01/2015**

Step	percent	Apprentice Base Wage	Health	Pension	Supplemental Unemployment	Total Rate
1	35	\$17.57	\$10.32	\$5.54	\$0.00	\$33.43
2	40	\$20.08	\$10.32	\$6.27	\$0.00	\$36.67
3	55	\$27.62	\$10.32	\$8.42	\$0.00	\$46.36
4	65	\$32.64	\$10.32	\$9.87	\$0.00	\$52.83
5	75	\$37.66	\$10.32	\$11.30	\$0.00	\$59.28

**Effective Date - 09/01/2015**

Step	percent	Apprentice Base Wage	Health	Pension	Supplemental Unemployment	Total Rate
1	35	\$17.92	\$10.32	\$5.54	\$0.00	\$33.78
2	40	\$20.48	\$10.32	\$6.27	\$0.00	\$37.07
3	55	\$28.17	\$10.32	\$8.42	\$0.00	\$46.91
4	65	\$33.29	\$10.32	\$9.87	\$0.00	\$53.48
5	75	\$38.41	\$10.32	\$11.30	\$0.00	\$60.03

**Notes:**

\*\* 1:2; 2:6; 3:10; 4:14; 5:19/Steps are 1 yr  
Step4 with lic\$56.05 Step5 with lic\$62.48

**Apprentice to Journeyworker Ratio:\*\***

PNEUMATIC CONTROLS (TEMP.)	03/01/2015	\$48.69	\$9.70	\$16.89	\$0.00	\$75.28
PIPEFITTERS LOCAL 537	09/01/2015	\$49.69	\$9.70	\$16.89	\$0.00	\$76.28
	03/01/2016	\$50.69	\$9.70	\$16.89	\$0.00	\$77.28
	09/01/2016	\$51.69	\$9.70	\$16.89	\$0.00	\$78.28
	03/01/2017	\$52.69	\$9.70	\$16.89	\$0.00	\$79.28

For apprentice rates see "Apprentice- PIPEFITTER" or "PLUMBER/PIPEFITTER"

PNEUMATIC DRILL/TOOL OPERATOR	06/01/2015	\$35.60	\$7.30	\$12.95	\$0.00	\$55.85
LABORERS - ZONE 1	12/01/2015	\$36.35	\$7.30	\$12.95	\$0.00	\$56.60
	06/01/2016	\$37.10	\$7.30	\$12.95	\$0.00	\$57.35
	12/01/2016	\$38.10	\$7.30	\$12.95	\$0.00	\$58.35

For apprentice rates see "Apprentice- LABORER"

POWDERMAN & BLASTER	06/01/2015	\$36.35	\$7.30	\$12.95	\$0.00	\$56.60
LABORERS - ZONE 1	12/01/2015	\$37.10	\$7.30	\$12.95	\$0.00	\$57.35
	06/01/2016	\$37.85	\$7.30	\$12.95	\$0.00	\$58.10
	12/01/2016	\$38.85	\$7.30	\$12.95	\$0.00	\$59.10

For apprentice rates see "Apprentice- LABORER"

POWER SHOVEL/DERRICK/TRENCHING MACHINE	06/01/2015	\$42.83	\$10.00	\$14.55	\$0.00	\$67.38
OPERATING ENGINEERS LOCAL 4	12/01/2015	\$44.08	\$10.00	\$14.55	\$0.00	\$68.63
	06/01/2016	\$44.83	\$10.00	\$14.55	\$0.00	\$69.38
	12/01/2016	\$46.08	\$10.00	\$14.55	\$0.00	\$70.63
	06/01/2017	\$47.08	\$10.00	\$14.55	\$0.00	\$71.63
	12/01/2017	\$48.08	\$10.00	\$14.55	\$0.00	\$72.63

For apprentice rates see "Apprentice- OPERATING ENGINEERS"

Classification	Effective Date	Base Wage	Health	Pension	Supplemental Unemployment	Total Rate
PUMP OPERATOR (CONCRETE) <i>OPERATING ENGINEERS LOCAL 4</i>	06/01/2015	\$42.83	\$10.00	\$14.55	\$0.00	\$67.38
	12/01/2015	\$44.08	\$10.00	\$14.55	\$0.00	\$68.63
	06/01/2016	\$44.83	\$10.00	\$14.55	\$0.00	\$69.38
	12/01/2016	\$46.08	\$10.00	\$14.55	\$0.00	\$70.63
	06/01/2017	\$47.08	\$10.00	\$14.55	\$0.00	\$71.63
	12/01/2017	\$48.08	\$10.00	\$14.55	\$0.00	\$72.63
For apprentice rates see "Apprentice- OPERATING ENGINEERS"						
PUMP OPERATOR (DEWATERING, OTHER) <i>OPERATING ENGINEERS LOCAL 4</i>	06/01/2015	\$29.61	\$10.00	\$14.55	\$0.00	\$54.16
	12/01/2015	\$30.48	\$10.00	\$14.55	\$0.00	\$55.03
	06/01/2016	\$31.00	\$10.00	\$14.55	\$0.00	\$55.55
	12/01/2016	\$31.87	\$10.00	\$14.55	\$0.00	\$56.42
	06/01/2017	\$32.56	\$10.00	\$14.55	\$0.00	\$57.11
	12/01/2017	\$33.25	\$10.00	\$14.55	\$0.00	\$57.80
For apprentice rates see "Apprentice- OPERATING ENGINEERS"						
READY MIX CONCRETE DRIVERS after 4/30/10 (Drivers Hired After 4/30/2010) <i>TEAMSTERS LOCAL 25c</i>	05/01/2015	\$27.88	\$7.73	\$8.92	\$0.00	\$44.53
	07/01/2015	\$27.88	\$7.98	\$8.92	\$0.00	\$44.78
	05/01/2016	\$28.03	\$7.98	\$9.31	\$0.00	\$45.32
	07/01/2016	\$28.03	\$8.23	\$9.31	\$0.00	\$45.57
	05/01/2017	\$28.18	\$8.23	\$9.72	\$0.00	\$46.13
	07/01/2017	\$28.18	\$8.48	\$9.72	\$0.00	\$46.38
READY-MIX CONCRETE DRIVER <i>TEAMSTERS LOCAL 25c</i>	05/01/2015	\$29.18	\$7.73	\$8.92	\$0.00	\$45.83
	07/01/2015	\$29.18	\$7.98	\$8.92	\$0.00	\$46.08
	05/01/2016	\$29.33	\$7.98	\$9.31	\$0.00	\$46.62
	07/01/2016	\$29.33	\$8.23	\$9.31	\$0.00	\$46.87
	05/01/2017	\$29.48	\$8.23	\$9.72	\$0.00	\$47.43
	07/01/2017	\$29.48	\$8.48	\$9.72	\$0.00	\$47.68
RECLAIMERS <i>OPERATING ENGINEERS LOCAL 4</i>	06/01/2015	\$42.42	\$10.00	\$14.55	\$0.00	\$66.97
	12/01/2015	\$43.66	\$10.00	\$14.55	\$0.00	\$68.21
	06/01/2016	\$44.41	\$10.00	\$14.55	\$0.00	\$68.96
	12/01/2016	\$45.64	\$10.00	\$14.55	\$0.00	\$70.19
	06/01/2017	\$46.63	\$10.00	\$14.55	\$0.00	\$71.18
	12/01/2017	\$47.62	\$10.00	\$14.55	\$0.00	\$72.17
For apprentice rates see "Apprentice- OPERATING ENGINEERS"						
RESIDENTIAL WOOD FRAME (All Other Work) <i>CARPENTERS -ZONE 2 (Residential Wood)</i>	04/01/2011	\$24.24	\$8.67	\$15.51	\$0.00	\$48.42
RESIDENTIAL WOOD FRAME CARPENTER **	05/01/2011	\$24.24	\$6.34	\$6.23	\$0.00	\$36.81
** The Residential Wood Frame Carpenter classification applies only to the construction of new, wood frame residences that do not exceed four stories including the basement. <i>CARPENTERS -ZONE 2 (Residential Wood)</i>						
As of 9/1/09 Carpentry work on wood-frame residential WEATHERIZATION projects shall be paid the RESIDENTIAL WOOD FRAME CARPENTER rate.						

**Classification**

**Effective Date    Base Wage    Health    Pension    Supplemental Unemployment    Total Rate**

**Apprentice - CARPENTER (Residential Wood Frame) - Zone 2**

**Effective Date - 05/01/2011**

Step	percent	Apprentice Base Wage	Health	Pension	Supplemental Unemployment	Total Rate
1	60	\$14.54	\$6.34	\$0.00	\$0.00	\$20.88
2	60	\$14.54	\$6.34	\$6.23	\$0.00	\$27.11
3	65	\$15.76	\$6.34	\$6.23	\$0.00	\$28.33
4	70	\$16.97	\$6.34	\$6.23	\$0.00	\$29.54
5	75	\$18.18	\$6.34	\$6.23	\$0.00	\$30.75
6	80	\$19.39	\$6.34	\$6.23	\$0.00	\$31.96
7	85	\$20.60	\$6.34	\$6.23	\$0.00	\$33.17
8	90	\$21.82	\$6.34	\$6.23	\$0.00	\$34.39

**Notes:**

**Apprentice to Journeyworker Ratio:1:5**

RIDE-ON MOTORIZED BUGGY OPERATOR <i>LABORERS - ZONE 1</i>	06/01/2015	\$35.60	\$7.30	\$12.95	\$0.00	\$55.85
	12/01/2015	\$36.35	\$7.30	\$12.95	\$0.00	\$56.60
	06/01/2016	\$37.10	\$7.30	\$12.95	\$0.00	\$57.35
	12/01/2016	\$38.10	\$7.30	\$12.95	\$0.00	\$58.35

For apprentice rates see "Apprentice- LABORER"

ROLLER/SPREADER/MULCHING MACHINE <i>OPERATING ENGINEERS LOCAL 4</i>	06/01/2015	\$42.42	\$10.00	\$14.55	\$0.00	\$66.97
	12/01/2015	\$43.66	\$10.00	\$14.55	\$0.00	\$68.21
	06/01/2016	\$44.41	\$10.00	\$14.55	\$0.00	\$68.96
	12/01/2016	\$45.64	\$10.00	\$14.55	\$0.00	\$70.19
	06/01/2017	\$46.63	\$10.00	\$14.55	\$0.00	\$71.18
	12/01/2017	\$47.62	\$10.00	\$14.55	\$0.00	\$72.17

For apprentice rates see "Apprentice- OPERATING ENGINEERS"

ROOFER (Inc.Roofing Waterproofing &Roofing Damproofing) <i>ROOFERS LOCAL 33</i>	02/01/2015	\$40.11	\$10.50	\$11.60	\$0.00	\$62.21
	08/01/2015	\$41.01	\$10.50	\$11.60	\$0.00	\$63.11
	02/01/2016	\$41.91	\$10.50	\$11.60	\$0.00	\$64.01

**Classification**

**Effective Date   Base Wage   Health   Pension   Supplemental Unemployment   Total Rate**

**Apprentice - ROOFER - Local 33**

**Effective Date - 02/01/2015**

Step	percent	Apprentice Base Wage	Health	Pension	Supplemental Unemployment	Total Rate
1	50	\$20.06	\$10.50	\$3.38	\$0.00	\$33.94
2	60	\$24.07	\$10.50	\$11.60	\$0.00	\$46.17
3	65	\$26.07	\$10.50	\$11.60	\$0.00	\$48.17
4	75	\$30.08	\$10.50	\$11.60	\$0.00	\$52.18
5	85	\$34.09	\$10.50	\$11.60	\$0.00	\$56.19

**Effective Date - 08/01/2015**

Step	percent	Apprentice Base Wage	Health	Pension	Supplemental Unemployment	Total Rate
1	50	\$20.51	\$10.50	\$3.38	\$0.00	\$34.39
2	60	\$24.61	\$10.50	\$11.60	\$0.00	\$46.71
3	65	\$26.66	\$10.50	\$11.60	\$0.00	\$48.76
4	75	\$30.76	\$10.50	\$11.60	\$0.00	\$52.86
5	85	\$34.86	\$10.50	\$11.60	\$0.00	\$56.96

**Notes:** \*\* 1:5, 2:6-10, the 1:10; Reroofing: 1:4, then 1:1  
 Step 1 is 2000 hrs.; Steps 2-5 are 1000 hrs.

**Apprentice to Journeyworker Ratio:\*\***

ROOFER SLATE / TILE / PRECAST CONCRETE ROOFERS LOCAL 33	02/01/2015	\$40.36	\$10.50	\$11.60	\$0.00	\$62.46
	08/01/2015	\$41.26	\$10.50	\$11.60	\$0.00	\$63.36
	02/01/2016	\$42.16	\$10.50	\$11.60	\$0.00	\$64.26
For apprentice rates see "Apprentice- ROOFER"						
SHEETMETAL WORKER SHEETMETAL WORKERS LOCAL 17 - A	02/01/2015	\$43.28	\$10.20	\$20.54	\$2.22	\$76.24
	08/01/2015	\$44.28	\$10.20	\$20.54	\$2.22	\$77.24
	02/01/2016	\$45.28	\$10.20	\$20.54	\$2.22	\$78.24
	08/01/2016	\$46.43	\$10.20	\$20.54	\$2.22	\$79.39
	02/01/2017	\$47.53	\$10.20	\$20.54	\$2.22	\$80.49
	08/01/2017	\$48.63	\$10.20	\$20.54	\$2.22	\$81.59
	02/01/2018	\$49.78	\$10.20	\$20.54	\$2.22	\$82.74

**Classification**

**Effective Date   Base Wage   Health   Pension   Supplemental Unemployment   Total Rate**

**Apprentice - SHEET METAL WORKER - Local 17-A**

**Effective Date - 02/01/2015**

Step	percent	Apprentice Base Wage	Health	Pension	Supplemental Unemployment	Total Rate
1	40	\$17.31	\$10.20	\$4.58	\$0.00	\$32.09
2	40	\$17.31	\$10.20	\$4.58	\$0.00	\$32.09
3	45	\$19.48	\$10.20	\$9.09	\$1.16	\$39.93
4	45	\$19.48	\$10.20	\$9.09	\$1.16	\$39.93
5	50	\$21.64	\$10.20	\$9.91	\$1.25	\$43.00
6	50	\$21.64	\$10.20	\$10.16	\$1.26	\$43.26
7	60	\$25.97	\$10.20	\$11.55	\$1.43	\$49.15
8	65	\$28.13	\$10.20	\$12.38	\$1.52	\$52.23
9	75	\$32.46	\$10.20	\$14.02	\$1.70	\$58.38
10	85	\$36.79	\$10.20	\$15.16	\$1.86	\$64.01

**Effective Date - 08/01/2015**

Step	percent	Apprentice Base Wage	Health	Pension	Supplemental Unemployment	Total Rate
1	40	\$17.71	\$10.20	\$4.58	\$0.00	\$32.49
2	40	\$17.71	\$10.20	\$4.58	\$0.00	\$32.49
3	45	\$19.93	\$10.20	\$9.09	\$1.18	\$40.40
4	45	\$19.93	\$10.20	\$9.09	\$1.18	\$40.40
5	50	\$22.14	\$10.20	\$9.91	\$1.27	\$43.52
6	50	\$22.14	\$10.20	\$10.16	\$1.28	\$43.78
7	60	\$26.57	\$10.20	\$11.55	\$1.45	\$49.77
8	65	\$28.78	\$10.20	\$12.38	\$1.54	\$52.90
9	75	\$33.21	\$10.20	\$14.02	\$1.72	\$59.15
10	85	\$37.64	\$10.20	\$15.16	\$1.89	\$64.89

**Notes:**  
Steps are 6 mos.

**Apprentice to Journeyworker Ratio:1:4**

SIGN ERECTOR PAINTERS LOCAL 35 - ZONE 2	06/01/2013	\$25.81	\$7.07	\$7.05	\$0.00	\$39.93
--	------------	---------	--------	--------	--------	---------

**Classification**

**Effective Date   Base Wage   Health   Pension   Supplemental Unemployment   Total Rate**

**Apprentice - SIGN ERECTOR - Local 35 Zone 2**

**Effective Date - 06/01/2013**

Step	percent	Apprentice Base Wage	Health	Pension	Supplemental Unemployment	Total Rate
1	50	\$12.91	\$7.07	\$0.00	\$0.00	\$19.98
2	55	\$14.20	\$7.07	\$2.45	\$0.00	\$23.72
3	60	\$15.49	\$7.07	\$2.45	\$0.00	\$25.01
4	65	\$16.78	\$7.07	\$2.45	\$0.00	\$26.30
5	70	\$18.07	\$7.07	\$7.05	\$0.00	\$32.19
6	75	\$19.36	\$7.07	\$7.05	\$0.00	\$33.48
7	80	\$20.65	\$7.07	\$7.05	\$0.00	\$34.77
8	85	\$21.94	\$7.07	\$7.05	\$0.00	\$36.06
9	90	\$23.23	\$7.07	\$7.05	\$0.00	\$37.35

**Notes:**  
Steps are 4 mos.

**Apprentice to Journeyworker Ratio:1:1**

SPECIALIZED EARTH MOVING EQUIP < 35 TONS <i>TEAMSTERS JOINT COUNCIL NO. 10 ZONE A</i>	06/01/2015	\$33.04	\$9.91	\$9.33	\$0.00	\$52.28
	08/01/2015	\$33.04	\$10.41	\$9.33	\$0.00	\$52.78
	12/01/2015	\$33.04	\$10.41	\$10.08	\$0.00	\$53.53
	06/01/2016	\$33.54	\$10.41	\$10.08	\$0.00	\$54.03
	08/01/2016	\$33.54	\$10.91	\$10.08	\$0.00	\$54.53
	12/01/2016	\$33.54	\$10.91	\$10.89	\$0.00	\$55.34
SPECIALIZED EARTH MOVING EQUIP > 35 TONS <i>TEAMSTERS JOINT COUNCIL NO. 10 ZONE A</i>	06/01/2015	\$33.33	\$9.91	\$9.33	\$0.00	\$52.57
	08/01/2015	\$33.33	\$10.41	\$9.33	\$0.00	\$53.07
	12/01/2015	\$33.33	\$10.41	\$10.08	\$0.00	\$53.82
	06/01/2016	\$33.83	\$10.41	\$10.08	\$0.00	\$54.32
	08/01/2016	\$33.83	\$10.91	\$10.08	\$0.00	\$54.82
	12/01/2016	\$33.83	\$10.91	\$10.89	\$0.00	\$55.63
SPRINKLER FITTER <i>SPRINKLER FITTERS LOCAL 550 - (Section A) Zone 1</i>	03/01/2015	\$54.43	\$8.42	\$14.90	\$0.00	\$77.75
	10/01/2015	\$55.58	\$8.42	\$14.90	\$0.00	\$78.90
	01/01/2016	\$55.58	\$8.67	\$15.05	\$0.00	\$79.30
	03/01/2016	\$56.58	\$8.67	\$15.05	\$0.00	\$80.30
	10/01/2016	\$57.73	\$8.67	\$15.05	\$0.00	\$81.45
	03/01/2017	\$58.73	\$8.67	\$15.05	\$0.00	\$82.45



**Classification**

**Effective Date   Base Wage   Health   Pension   Supplemental Unemployment   Total Rate**

**Apprentice - SPRINKLER FITTER - Local 550 (Section A) Zone 1**

**Effective Date - 03/01/2015**

Step	percent	Apprentice Base Wage	Health	Pension	Supplemental Unemployment	Total Rate
1	35	\$19.05	\$8.42	\$8.40	\$0.00	\$35.87
2	40	\$21.77	\$8.42	\$8.40	\$0.00	\$38.59
3	45	\$24.49	\$8.42	\$8.40	\$0.00	\$41.31
4	50	\$27.22	\$8.42	\$8.40	\$0.00	\$44.04
5	55	\$29.94	\$8.42	\$8.40	\$0.00	\$46.76
6	60	\$32.66	\$8.42	\$8.40	\$0.00	\$49.48
7	65	\$35.38	\$8.42	\$8.40	\$0.00	\$52.20
8	70	\$38.10	\$8.42	\$8.40	\$0.00	\$54.92
9	75	\$40.82	\$8.42	\$8.40	\$0.00	\$57.64
10	80	\$43.54	\$8.42	\$8.40	\$0.00	\$60.36

**Effective Date - 10/01/2015**

Step	percent	Apprentice Base Wage	Health	Pension	Supplemental Unemployment	Total Rate
1	35	\$19.45	\$8.42	\$8.40	\$0.00	\$36.27
2	40	\$22.23	\$8.42	\$8.40	\$0.00	\$39.05
3	45	\$25.01	\$8.42	\$8.40	\$0.00	\$41.83
4	50	\$27.79	\$8.42	\$8.40	\$0.00	\$44.61
5	55	\$30.57	\$8.42	\$8.40	\$0.00	\$47.39
6	60	\$33.35	\$8.42	\$8.40	\$0.00	\$50.17
7	65	\$36.13	\$8.42	\$8.40	\$0.00	\$52.95
8	70	\$38.91	\$8.42	\$8.40	\$0.00	\$55.73
9	75	\$41.69	\$8.42	\$8.40	\$0.00	\$58.51
10	80	\$44.46	\$8.42	\$8.40	\$0.00	\$61.28

**Notes:** Apprentice entered prior 9/30/10:  
40/45/50/55/60/65/70/75/80/85  
Steps are 850 hours

**Apprentice to Journeyworker Ratio:1:3**

STEAM BOILER OPERATOR <i>OPERATING ENGINEERS LOCAL 4</i>	06/01/2015	\$42.42	\$10.00	\$14.55	\$0.00	\$66.97
	12/01/2015	\$43.66	\$10.00	\$14.55	\$0.00	\$68.21
	06/01/2016	\$44.41	\$10.00	\$14.55	\$0.00	\$68.96
	12/01/2016	\$45.64	\$10.00	\$14.55	\$0.00	\$70.19
	06/01/2017	\$46.63	\$10.00	\$14.55	\$0.00	\$71.18
	12/01/2017	\$47.62	\$10.00	\$14.55	\$0.00	\$72.17

For apprentice rates see "Apprentice- OPERATING ENGINEERS"

TAMPERS, SELF-PROPELLED OR TRACTOR DRAWN <i>OPERATING ENGINEERS LOCAL 4</i>	06/01/2015	\$42.42	\$10.00	\$14.55	\$0.00	\$66.97
	12/01/2015	\$43.66	\$10.00	\$14.55	\$0.00	\$68.21
	06/01/2016	\$44.41	\$10.00	\$14.55	\$0.00	\$68.96
	12/01/2016	\$45.64	\$10.00	\$14.55	\$0.00	\$70.19
	06/01/2017	\$46.63	\$10.00	\$14.55	\$0.00	\$71.18
	12/01/2017	\$47.62	\$10.00	\$14.55	\$0.00	\$72.17

For apprentice rates see "Apprentice- OPERATING ENGINEERS"

Classification	Effective Date	Base Wage	Health	Pension	Supplemental Unemployment	Total Rate
TELECOMMUNICATION TECHNICIAN <i>ELECTRICIANS LOCAL 103</i>	03/01/2015	\$33.88	\$13.00	\$13.70	\$0.00	\$60.58
	09/01/2015	\$34.60	\$13.00	\$13.72	\$0.00	\$61.32
	03/01/2016	\$35.31	\$13.00	\$13.74	\$0.00	\$62.05

**Apprentice - TELECOMMUNICATION TECHNICIAN - Local 103**

**Effective Date - 03/01/2015**

Step	percent	Apprentice Base Wage	Health	Pension	Supplemental Unemployment	Total Rate
1	40	\$13.55	\$13.00	\$0.41	\$0.00	\$26.96
2	40	\$13.55	\$13.00	\$0.41	\$0.00	\$26.96
3	45	\$15.25	\$13.00	\$10.87	\$0.00	\$39.12
4	45	\$15.25	\$13.00	\$10.87	\$0.00	\$39.12
5	50	\$16.94	\$13.00	\$11.11	\$0.00	\$41.05
6	55	\$18.63	\$13.00	\$11.38	\$0.00	\$43.01
7	60	\$20.33	\$13.00	\$11.64	\$0.00	\$44.97
8	65	\$22.02	\$13.00	\$11.89	\$0.00	\$46.91
9	70	\$23.72	\$13.00	\$12.15	\$0.00	\$48.87
10	75	\$25.41	\$13.00	\$12.41	\$0.00	\$50.82

**Effective Date - 09/01/2015**

Step	percent	Apprentice Base Wage	Health	Pension	Supplemental Unemployment	Total Rate
1	40	\$13.84	\$13.00	\$0.42	\$0.00	\$27.26
2	40	\$13.84	\$13.00	\$0.42	\$0.00	\$27.26
3	45	\$15.57	\$13.00	\$10.88	\$0.00	\$39.45
4	45	\$15.57	\$13.00	\$10.88	\$0.00	\$39.45
5	50	\$17.30	\$13.00	\$11.14	\$0.00	\$41.44
6	55	\$19.03	\$13.00	\$11.39	\$0.00	\$43.42
7	60	\$20.76	\$13.00	\$11.65	\$0.00	\$45.41
8	65	\$22.49	\$13.00	\$11.90	\$0.00	\$47.39
9	70	\$24.22	\$13.00	\$12.17	\$0.00	\$49.39
10	75	\$25.95	\$13.00	\$12.43	\$0.00	\$51.38

**Notes:**

**Apprentice to Journeyworker Ratio:1:1**

TERRAZZO FINISHERS <i>BRICKLAYERS LOCAL 3 - MARBLE &amp; TILE</i>	02/01/2015	\$47.90	\$10.18	\$18.50	\$0.00	\$76.58
	08/01/2015	\$48.80	\$10.18	\$18.57	\$0.00	\$77.55
	02/01/2016	\$49.37	\$10.18	\$18.57	\$0.00	\$78.12
	08/01/2016	\$50.27	\$10.18	\$18.65	\$0.00	\$79.10
	02/01/2017	\$50.84	\$10.18	\$18.65	\$0.00	\$79.67

**Classification**

**Effective Date   Base Wage   Health   Pension   Supplemental Unemployment   Total Rate**

**Apprentice - TERRAZZO FINISHER - Local 3 Marble & Tile**

**Effective Date - 02/01/2015**

Step	percent	Apprentice Base Wage	Health	Pension	Supplemental Unemployment	Total Rate
1	50	\$23.95	\$10.18	\$18.50	\$0.00	\$52.63
2	60	\$28.74	\$10.18	\$18.50	\$0.00	\$57.42
3	70	\$33.53	\$10.18	\$18.50	\$0.00	\$62.21
4	80	\$38.32	\$10.18	\$18.50	\$0.00	\$67.00
5	90	\$43.11	\$10.18	\$18.50	\$0.00	\$71.79

**Effective Date - 08/01/2015**

Step	percent	Apprentice Base Wage	Health	Pension	Supplemental Unemployment	Total Rate
1	50	\$24.40	\$10.18	\$18.57	\$0.00	\$53.15
2	60	\$29.28	\$10.18	\$18.57	\$0.00	\$58.03
3	70	\$34.16	\$10.18	\$18.57	\$0.00	\$62.91
4	80	\$39.04	\$10.18	\$18.57	\$0.00	\$67.79
5	90	\$43.92	\$10.18	\$18.57	\$0.00	\$72.67

**Notes:**

**Apprentice to Journeyworker Ratio:1:3**

TEST BORING DRILLER <i>LABORERS - FOUNDATION AND MARINE</i>	06/01/2015	\$36.70	\$7.30	\$13.15	\$0.00	\$57.15
	12/01/2015	\$37.45	\$7.30	\$13.15	\$0.00	\$57.90
	06/01/2016	\$38.20	\$7.30	\$13.15	\$0.00	\$58.65
	12/01/2016	\$39.20	\$7.30	\$13.15	\$0.00	\$59.65

For apprentice rates see "Apprentice- LABORER"

TEST BORING DRILLER HELPER <i>LABORERS - FOUNDATION AND MARINE</i>	06/01/2015	\$35.42	\$7.30	\$13.15	\$0.00	\$55.87
	12/01/2015	\$36.17	\$7.30	\$13.15	\$0.00	\$56.62
	06/01/2016	\$36.92	\$7.30	\$13.15	\$0.00	\$57.37
	12/01/2016	\$37.92	\$7.30	\$13.15	\$0.00	\$58.37

For apprentice rates see "Apprentice- LABORER"

TEST BORING LABORER <i>LABORERS - FOUNDATION AND MARINE</i>	06/01/2015	\$35.30	\$7.30	\$13.15	\$0.00	\$55.75
	12/01/2015	\$36.05	\$7.30	\$13.15	\$0.00	\$56.50
	06/01/2016	\$36.80	\$7.30	\$13.15	\$0.00	\$57.25
	12/01/2016	\$37.80	\$7.30	\$13.15	\$0.00	\$58.25

For apprentice rates see "Apprentice- LABORER"

TRACTORS/PORTABLE STEAM GENERATORS <i>OPERATING ENGINEERS LOCAL 4</i>	06/01/2015	\$42.42	\$10.00	\$14.55	\$0.00	\$66.97
	12/01/2015	\$43.66	\$10.00	\$14.55	\$0.00	\$68.21
	06/01/2016	\$44.41	\$10.00	\$14.55	\$0.00	\$68.96
	12/01/2016	\$45.64	\$10.00	\$14.55	\$0.00	\$70.19
	06/01/2017	\$46.63	\$10.00	\$14.55	\$0.00	\$71.18
	12/01/2017	\$47.62	\$10.00	\$14.55	\$0.00	\$72.17

For apprentice rates see "Apprentice- OPERATING ENGINEERS"

Classification	Effective Date	Base Wage	Health	Pension	Supplemental Unemployment	Total Rate
TRAILERS FOR EARTH MOVING EQUIPMENT <i>TEAMSTERS JOINT COUNCIL NO. 10 ZONE A</i>	06/01/2015	\$33.62	\$9.91	\$9.33	\$0.00	\$52.86
	08/01/2015	\$33.62	\$10.41	\$9.33	\$0.00	\$53.36
	12/01/2015	\$33.62	\$10.41	\$10.08	\$0.00	\$54.11
	06/01/2016	\$34.12	\$10.41	\$10.08	\$0.00	\$54.61
	08/01/2016	\$34.12	\$10.91	\$10.08	\$0.00	\$55.11
	12/01/2016	\$34.12	\$10.91	\$10.89	\$0.00	\$55.92
TUNNEL WORK - COMPRESSED AIR <i>LABORERS (COMPRESSED AIR)</i>	06/01/2015	\$47.58	\$7.30	\$13.55	\$0.00	\$68.43
	12/01/2015	\$48.33	\$7.30	\$13.55	\$0.00	\$69.18
	06/01/2016	\$49.08	\$7.30	\$13.55	\$0.00	\$69.93
	12/01/2016	\$50.08	\$7.30	\$13.55	\$0.00	\$70.93
For apprentice rates see "Apprentice- LABORER"						
TUNNEL WORK - COMPRESSED AIR (HAZ. WASTE) <i>LABORERS (COMPRESSED AIR)</i>	06/01/2015	\$49.58	\$7.30	\$13.55	\$0.00	\$70.43
	12/01/2015	\$50.33	\$7.30	\$13.55	\$0.00	\$71.18
	06/01/2016	\$51.08	\$7.30	\$13.55	\$0.00	\$71.93
	12/01/2016	\$52.08	\$7.30	\$13.55	\$0.00	\$72.93
For apprentice rates see "Apprentice- LABORER"						
TUNNEL WORK - FREE AIR <i>LABORERS (FREE AIR TUNNEL)</i>	06/01/2015	\$39.65	\$7.30	\$13.55	\$0.00	\$60.50
	12/01/2015	\$40.40	\$7.30	\$13.55	\$0.00	\$61.25
	06/01/2016	\$41.15	\$7.30	\$13.55	\$0.00	\$62.00
	12/01/2016	\$42.15	\$7.30	\$13.55	\$0.00	\$63.00
For apprentice rates see "Apprentice- LABORER"						
TUNNEL WORK - FREE AIR (HAZ. WASTE) <i>LABORERS (FREE AIR TUNNEL)</i>	06/01/2015	\$41.65	\$7.30	\$13.55	\$0.00	\$62.50
	12/01/2015	\$42.40	\$7.30	\$13.55	\$0.00	\$63.25
	06/01/2016	\$43.15	\$7.30	\$13.55	\$0.00	\$64.00
	12/01/2016	\$44.15	\$7.30	\$13.55	\$0.00	\$65.00
For apprentice rates see "Apprentice- LABORER"						
VAC-HAUL <i>TEAMSTERS JOINT COUNCIL NO. 10 ZONE A</i>	06/01/2015	\$33.04	\$9.91	\$9.33	\$0.00	\$52.28
	08/01/2015	\$33.04	\$10.41	\$9.33	\$0.00	\$52.78
	12/01/2015	\$33.04	\$10.41	\$10.08	\$0.00	\$53.53
	06/01/2016	\$33.54	\$10.41	\$10.08	\$0.00	\$54.03
	08/01/2016	\$33.54	\$10.91	\$10.08	\$0.00	\$54.53
	12/01/2016	\$33.54	\$10.91	\$10.89	\$0.00	\$55.34
WAGON DRILL OPERATOR <i>LABORERS - ZONE 1</i>	06/01/2015	\$35.60	\$7.30	\$12.95	\$0.00	\$55.85
	12/01/2015	\$36.35	\$7.30	\$12.95	\$0.00	\$56.60
	06/01/2016	\$37.10	\$7.30	\$12.95	\$0.00	\$57.35
	12/01/2016	\$38.10	\$7.30	\$12.95	\$0.00	\$58.35
For apprentice rates see "Apprentice- LABORER"						
WASTE WATER PUMP OPERATOR <i>OPERATING ENGINEERS LOCAL 4</i>	06/01/2015	\$42.83	\$10.00	\$14.55	\$0.00	\$67.38
	12/01/2015	\$44.08	\$10.00	\$14.55	\$0.00	\$68.63
	06/01/2016	\$44.83	\$10.00	\$14.55	\$0.00	\$69.38
	12/01/2016	\$46.08	\$10.00	\$14.55	\$0.00	\$70.63
	06/01/2017	\$47.08	\$10.00	\$14.55	\$0.00	\$71.63
12/01/2017	\$48.08	\$10.00	\$14.55	\$0.00	\$72.63	
For apprentice rates see "Apprentice- OPERATING ENGINEERS"						

Classification	Effective Date	Base Wage	Health	Pension	Supplemental Unemployment	Total Rate
WATER METER INSTALLER <i>PLUMBERS &amp; GASFITTERS LOCAL 12</i>	03/01/2015	\$50.21	\$10.32	\$14.89	\$0.00	\$75.42
	09/01/2015	\$51.21	\$10.32	\$14.89	\$0.00	\$76.42
	03/01/2016	\$52.36	\$10.32	\$14.89	\$0.00	\$77.57
	09/01/2016	\$53.41	\$10.32	\$14.89	\$0.00	\$78.62
	03/01/2017	\$54.41	\$10.32	\$14.89	\$0.00	\$79.62
For apprentice rates see "Apprentice- PLUMBER/PIPEFITTER" or "PLUMBER/GASFITTER"						
<b>Outside Electrical - East</b>						
CABLE TECHNICIAN (Power Zone) <i>OUTSIDE ELECTRICAL WORKERS - EAST LOCAL 104</i>	09/01/2013	\$25.66	\$8.70	\$4.48	\$0.00	\$38.84
For apprentice rates see "Apprentice- LINEMAN"						
CABLEMAN (Underground Ducts & Cables) <i>OUTSIDE ELECTRICAL WORKERS - EAST LOCAL 104</i>	09/01/2013	\$36.55	\$8.70	\$6.58	\$0.00	\$51.83
For apprentice rates see "Apprentice- LINEMAN"						
DRIVER / GROUNDMAN CDL <i>OUTSIDE ELECTRICAL WORKERS - EAST LOCAL 104</i>	09/01/2013	\$29.94	\$8.70	\$6.05	\$0.00	\$44.69
For apprentice rates see "Apprentice- LINEMAN"						
DRIVER / GROUNDMAN -Inexperienced (<2000 Hrs) <i>OUTSIDE ELECTRICAL WORKERS - EAST LOCAL 104</i>	09/01/2013	\$23.52	\$8.70	\$5.24	\$0.00	\$37.46
For apprentice rates see "Apprentice- LINEMAN"						
EQUIPMENT OPERATOR (Class A CDL) <i>OUTSIDE ELECTRICAL WORKERS - EAST LOCAL 104</i>	09/01/2013	\$36.35	\$8.70	\$9.43	\$0.00	\$54.48
For apprentice rates see "Apprentice- LINEMAN"						
EQUIPMENT OPERATOR (Class B CDL) <i>OUTSIDE ELECTRICAL WORKERS - EAST LOCAL 104</i>	09/01/2013	\$32.08	\$8.70	\$6.59	\$0.00	\$47.37
For apprentice rates see "Apprentice- LINEMAN"						
GROUNDMAN <i>OUTSIDE ELECTRICAL WORKERS - EAST LOCAL 104</i>	09/01/2013	\$23.52	\$8.70	\$3.72	\$0.00	\$35.94
For apprentice rates see "Apprentice- LINEMAN"						
GROUNDMAN -Inexperienced (<2000 Hrs.) <i>OUTSIDE ELECTRICAL WORKERS - EAST LOCAL 104</i>	09/01/2013	\$19.25	\$8.70	\$2.85	\$0.00	\$30.80
For apprentice rates see "Apprentice- LINEMAN"						
JOURNEYMAN LINEMAN <i>OUTSIDE ELECTRICAL WORKERS - EAST LOCAL 104</i>	09/01/2013	\$42.77	\$8.70	\$11.78	\$0.00	\$63.25

**Apprentice - LINEMAN (Outside Electrical) - East Local 104**

**Effective Date - 09/01/2013**

Step	percent	Apprentice Base Wage	Health	Pension	Supplemental Unemployment	Total Rate
1	60	\$25.66	\$8.70	\$4.24	\$0.00	\$38.60
2	65	\$27.80	\$8.70	\$4.71	\$0.00	\$41.21
3	70	\$29.94	\$8.70	\$5.43	\$0.00	\$44.07
4	75	\$32.08	\$8.70	\$6.16	\$0.00	\$46.94
5	80	\$34.22	\$8.70	\$6.88	\$0.00	\$49.80
6	85	\$36.35	\$8.70	\$7.62	\$0.00	\$52.67
7	90	\$38.49	\$8.70	\$8.83	\$0.00	\$56.02

**Notes:**

**Apprentice to Journeyworker Ratio:1:2**

Classification	Effective Date	Base Wage	Health	Pension	Supplemental Unemployment	Total Rate
TELEDATA CABLE SPLICER <i>OUTSIDE ELECTRICAL WORKERS - EAST LOCAL 104</i>	01/01/2015	\$28.12	\$4.25	\$3.09	\$0.00	\$35.46
	01/01/2016	\$28.98	\$4.25	\$3.12	\$0.00	\$36.35
TELEDATA LINEMAN/EQUIPMENT OPERATOR <i>OUTSIDE ELECTRICAL WORKERS - EAST LOCAL 104</i>	01/01/2015	\$26.49	\$4.25	\$3.04	\$0.00	\$33.78
	01/01/2016	\$27.31	\$4.25	\$3.07	\$0.00	\$34.63
TELEDATA WIREMAN/INSTALLER/TECHNICIAN <i>OUTSIDE ELECTRICAL WORKERS - EAST LOCAL 104</i>	01/01/2015	\$26.49	\$4.25	\$3.04	\$0.00	\$33.78
	01/01/2016	\$27.31	\$4.25	\$3.07	\$0.00	\$34.63
TREE TRIMMER <i>OUTSIDE ELECTRICAL WORKERS - EAST LOCAL 104</i>	02/01/2015	\$18.05	\$3.55	\$0.00	\$0.00	\$21.60
	01/31/2016	\$18.51	\$3.55	\$0.00	\$0.00	\$22.06
This classification applies only to tree work done: (a) for a utility company, R.E.A. cooperative, or railroad or coal mining company, and (b) for the purpose of operating, maintaining, or repairing the utility company's equipment, and (c) by a person who is using hand or mechanical cutting methods and is not on the ground. This classification does not apply to wholesale tree removal.						
TREE TRIMMER GROUNDMAN <i>OUTSIDE ELECTRICAL WORKERS - EAST LOCAL 104</i>	02/01/2015	\$15.92	\$3.55	\$0.00	\$0.00	\$19.47
	01/31/2016	\$16.32	\$3.55	\$0.00	\$0.00	\$19.87
This classification applies only to tree work done: (a) for a utility company, R.E.A. cooperative, or railroad or coal mining company, and (b) for the purpose of operating, maintaining, or repairing the utility company's equipment, and (c) by a person who is using hand or mechanical cutting methods and is on the ground. This classification does not apply to wholesale tree removal.						

Additional Apprentices Information:

Minimum wage rates for apprentices employed on public works projects are listed above as a percentage of the pre-determined hourly wage rate established by the Commissioner under the provisions of the M.G.L. c. 149, ss. 26-27D. Apprentice ratios are established by the Division of Apprenticeship Training pursuant to M.G.L. c. 23, ss. 11E-11L.

All apprentices must be registered with the Division of Apprenticeship Training in accordance with M.G.L. c. 23, ss. 11E-11L.

All steps are six months (1000 hours.)

Ratios are expressed in allowable number of apprentices to journeymen or fraction thereof, unless otherwise specified.

\*\* Multiple ratios are listed in the comment field.

\*\*\* APP to JM; 1:1, 2:2, 2:3, 3:4, 4:4, 4:5, 4:6, 5:7, 6:7, 6:8, 6:9, 7:10, 8:10, 8:11, 8:12, 9:13, 10:13, 10:14, etc.

\*\*\*\* APP to JM; 1:1, 1:2, 2:3, 2:4, 3:5, 4:6, 4:7, 5:8, 6:9, 6:10, 7:11, 8:12, 8:13, 9:14, 10:15, 10:16, etc.