

Invitation for Bids (IFB)

BID #15-07

For

Roadway Management/Various Locations

Town of Arlington

Legal Notice of Invitation for Bid for Public Works Services

The Town of Arlington acting thru its Town Manager invites bids for the following public works services to be provided from date of contract with the option of two 1-year extensions at the sole option of the Town:

Description

MassDOT Prequalification Required

Item 1 Roadway Management – Highway Construction

Y

The Town of Arlington is administering this procurement and will identify responsible and responsive low bidders. The Town reserves the right to accept or reject any and all bids or portions thereof, to waive any informalities in bidding, and to award in the best interest of the Town.

Bid documents may be obtained by contacting Domenic Lanzillotti by email at dlanzillotti@town.arlington.ma.us, or on the Town website www.arlingtonma.gov/purchasing beginning June 15, 2015. Massachusetts Prevailing Wage Laws apply to all services. Bid bonds and Labor & Materials bond are required. Sealed bids will be publicly opened at the Town Managers Office, Town Hall, 730 Massachusetts Ave., Arlington, MA, June 30, 2015, 10:00 AM.

Please note that bids from vendors not listed by MassDOT as prequalified in the specific class of work with a single contract limit at or above the dollar value of the projects or who are not listed on a waiver contractor bid list will be rejected.

Advertisements placed as follows:

Central Register

Published: June 10, 2015

Local Advertisement

Published: June 11, 2015

Adam W. Chapdelaine
Town Manager

June 15, 2015

Table of Contents

Legal Notice of Invitation for Bids for Public Works Services.....

Section I: Terminology.....

Section II: General Information.....

Section III: Terms and Conditions.....

Section IV: Forms.....

Form A - General Bid Form.....

Form B – Non-Collusion Statement.....

Form C – Taxes Paid Certification.....

Form D – Contract.....

Form E – Letter of Availability.....

Appendix A – List of Bid Documents.....

Appendix B – Prevailing Wage Rates.....

Appendix C – Estimated Quantities.....

Appendix D – Example MBE/WBE Letters of Intent & Schedules of Participation.....

Appendix E – MassDOT Price Adjustment Clauses.....

Section 1: Terminology

The following terms, references and conventions have the meaning indicated:

Term	General Meaning
City Town Municipality	Awarding Authority or Representative
Authorized Representative Designee	Person named as such by the Municipality
Director Director of Public Works Engineer Superintendent	Municipality's Authorized Representative or his/her designee, or Municipality's manager of the work performed under Contract
DPW Department Agency	The Municipality's department responsible for directing the work performed under Contract
Low Bidder(s) Successful Bidder(s) Contractor(s)	The Low Bidder with whom a Contract has or may be executed
Bid Sheet(s)/Form(s) Proposal Sheet(s)/Forms(s)	Bid Form(s) Bid Price Form(s)

Section II: General Information

1. Introduction

- a. The Town of Arlington, 730 Massachusetts Avenue, Arlington MA, 02476 is the sole municipality administering this bid
- b. The Town of Arlington will identify low bidders and recommend award, and reserves the right to accept or reject any bids deemed in its best interest

2. About the IFB Documents

- a. All bidders will receive this document, Bid #15-07 - Invitation for Bid which contains all required information for bidders and forms, Specifications and Bid Price Forms, and all Prevailing Wage
- b. See Appendix A, List of Bid Documents for documents that apply to this IFB.
- c. Any Addenda issued will be distributed via e-mail to all parties that have obtained IFB Documents and will be posted on the Town website.
- d. A bidder may correct, modify, or withdraw a bid by written notice received by the Purchasing Officer not later than the close of business on the day before the bid opening. Bid modifications must be submitted in a sealed envelope clearly labeled "Modification No.____." Each modification must be numbered in sequence, must reference the original IFB and must be signed by the same person who signed the General Bid Form or a surrogate so authorized in writing.
- e. After the bid opening, a bidder may not change any provision of the bid in a manner prejudicial to the interests of the Town, or fair competition as determined by the Town.

3. Estimated Quantities

- a. This IFB recites quantities of services and/or goods that reflect estimates of the work to be engaged in by the Town of Arlington during the initial contract term and each possible
-

extension. The quantities, as estimated, may or may not be purchased during a contract term or extension. The Town of Arlington reserves the right to exceed or not meet the estimated quantities as its needs dictate. Estimated quantities will be used for comparison of bids, determining the Low Bidder and establishing the Bid Bond/Deposit and Performance Bond amounts.

4. Pre-Bid Conference

- a. Thursday June 18, 2015, 2:00 PM, DPW Engineering Office, 2nd Floor, 51 Grove St., Arlington, MA.

5. Bidder Eligibility

- a. Bidders must comply with all requirements of this IFB in order to be considered eligible for award.
- b. Please note that bids from vendors not listed by MassDOT as prequalified in the specific class of work with a single contract limit at or above the dollar value of the projects or who are not listed on a waiver contractor bid list will be rejected.

6. Award

- a. The Town of Arlington will identify valid Low Bidders (i.e. the responsive¹ and responsible² bidders offering the lowest aggregate prices as indicated on the Item-specific Bid Price Forms).
- b. Award recommendations will be based on the prices enclosed in bold borders
- c. as indicated on the Bid Price Forms. Bid Price Form arithmetic is apparent.
- d. Low Bidders and Second Low Bidders will be identified for each of the Bid Items shown on the Bid Price Forms as the subject of an award.

¹ Bidders who comply with all requirements for submittal of bids will be considered "Responsive".

² Bidders who are listed by MassDOT as prequalified in the specific class of work with a single contract limit at or above the dollar value of the projects or who are listed on a waiver contractor bid list and whose references are satisfactory to the Town of Arlington shall be considered "Responsible".

- Contract shall be for the period of one year from the date of contract
- b. All general requirements and terms and conditions contained in the "GENERAL INFORMATION" section of this IFB shall become part of and contained in any resulting Contract, except that terms, conditions and requirements peculiar to specifications for named types of work shall supersede.
 - c. Low Bidders are required to certify at the time of contract execution, using the form contained in this document entitled Taxes Paid Certification (Form C) that they have met all Massachusetts tax obligations as a condition of eligibility to contract with member municipalities. Municipalities are prohibited by law from executing Contracts without this Certification.
 - d. This IFB document and all included forms and requirements will be incorporated into all resulting contracts.

8. Price Adjustment Clauses

- a. MassDOT has notified all cities and towns in the Commonwealth of Massachusetts that there are new price adjustment requirements that must be included in the bid documents for contracts to be funded by Chapter 90 funds. All municipalities are required to include price adjustment clauses for diesel fuel, gasoline, liquid asphalt, Portland cement concrete, and steel.
 - b. This IFB hereby incorporates the MassDOT specific contract language for the required price adjustment clauses for diesel fuel, gasoline, liquid asphalt, Portland cement concrete, and steel. Copies of these Special Provisions can be found in Appendix E, Price Adjustment Clauses and on the MassDOT website.
 - c. Base Prices for these items will be the fixed prices determined to be in place as of the date of bid as posted on the MassDOT website.
 - d. All scheduled work will be performed at the prices in effect at the time the work is performed.
 - e. In the event that scheduled work is postponed by the Contractor, pricing will be locked-in at the pricing applicable to the originally scheduled work period.
-

- f. In the event that scheduled work is postponed by the Town of Arlington, Paragraph C above shall apply.

9. Applicable Laws and Certifications

- a. Municipal governments are exempt from Massachusetts sales tax and U.S. excise tax.
- b. Bids are subject to the laws and certifications noted in the following table:

Description	<div style="text-align: right; margin-right: 10px;"><i>MassDOT Prequalification or Waiver REQUIRED⁴</i></div> <div style="text-align: right; margin-right: 10px;">Prevailing Wage Law APPLIES⁵</div> <div style="text-align: right; margin-right: 10px;">MGL c30B APPLIES</div> <div style="text-align: right;">MGL c.30 s.39M APPLIES</div>			
	Item 1 Roadway Management – Highway Construction	Y		Y

- d. Low Bidders must provide proof of possession in good standing of all applicable licenses and must obtain, prior to performing contract work, all permits required by the Towns unless waived by the appropriate issuing authority.

⁴ Vendors must be listed by MassDOT as prequalified in the specific class of work with a single contract limit at or above the dollar value of the projects or be listed on a waiver contractor bid list.

⁵ Contractors must pay their employees the Prevailing Wages provided to the awarding authority by the Massachusetts Division of Occupational Safety pursuant to MGL c.149. Prevailing Wage information and rates are normally included in the IFB documents. Occasionally, the required documents may be delivered to bidders under separate cover. Awarding authorities will require copies of certified payrolls before payments can be made to contractors for work performed.

10. How to Submit a Bid

- a. Bids must be submitted in a sealed envelope and received prior to **11:00 AM June 30, 2015**
to:

Domenic Lanzillotti, Purchasing Officer
Town Managers Office
730 Massachusetts Avenue
Arlington, MA 02476

- b. All bid envelopes, including all outer envelopes for mailing/shipping (e.g. UPS, DHL, FedEx), **must** also clearly display the following information on the exterior:

Purchasing Department
BID #15-07, ROADWAY MANAGEMENT/VARIOUS LOCATIONS

Bid Opening Date: June 30, 2015, 11:00 AM

- c. Bids from vendors not listed by MassDOT as prequalified in the specific class of work with a single contract limit at or above the dollar value of the projects or who are not listed on a waiver contractor bid list will be rejected.
- d. Bids must be submitted on the accompanying applicable Bid Price Forms. All blanks must be marked with a bid price or an extended price, or marked out so as to clearly indicate the Bidder's intentions.
- e. Bids must be signed and dated by an authorized representative of the Bidder and accompanied by proof of authorization (e.g. certificate of corporate vote, corporate seal, etc.) when representing a business entity other than a sole proprietorship.
- f. Bid Submittal CHECKLIST

One (1) envelope is required for the bid as follows:

- Envelope contains the following items properly completed, executed and sealed (if needed). **Please submit only the listed required forms and documents and in the order requested. Do not include copies of the IFB and specifications:**
 - An acceptable form of Bid Bond (see Section 13)
-

Form A – the General Bid Form

Form B – the Non-Collusion Statement

Form C – the Taxes Paid Certificate

A list of References numbering not less than three (3) Massachusetts municipalities with specific, complete, current and accurate contact information.

A list of Subcontractors to whom the Contractor may sub-contract any of its scheduled work.

A list of municipal work performed within the past three (3) years.

The Bid Price Form(s) that applies to the Item(s) being bid.

- g. Bids from vendors not listed by MassDOT as prequalified in the specific class of work with a single contract limit at or above the dollar value of the projects or who are not listed on a waiver contractor bid list will be marked “REJECTED”, set aside unopened, and retained by the Town for the record.
- h. Prices as Bid shall remain firm⁶ 1) for the term of the Contract; and 2) for all work regardless of the Town’s work quantities.
- i. Bids shall remain valid and in effect for a period of sixty (60) days beyond 1) the initial date of opening and 2) the end of the specified contract periods to allow sufficient time for action by The Town.

⁶ Subject to adjustment per IFB Section 8, Price Adjustment Clauses

- j. Low Bidders shall process and deliver required Contract documents within seven (7) calendar days of receipt of notification by the Town of Arlington of their “Intention to Award a Contract”.

11. Bid Pricing

- a. The unit price for any item, bid and contracted for, unless otherwise noted or specified, shall include full compensation for all materials, equipment, tools, labor and incidental work, necessary to complete the item to the satisfaction of the Municipality. The prices without exception, shall be net, not subject to discount, and shall include all royalties and costs arising from patents, trademarks, and copyrights in any way involved in the work.

12. Completing the Bid Price Forms

- a. Normally, all prices called for contribute to the calculation of an award amount. There may be exceptions, in which case, all unit prices called for must be bid in order for a bid to be considered valid.

	Estimated Quantity	x	Bid Price / Unit	=	Total
2. PW SERVICE					
_____			_____		
_____			_____		
_____			_____		
_____			_____		
_____			_____		
_____			_____		
_____			_____		

- b. Unit prices preceded by “x” and followed by “=” indicate an extended price must be calculated.
- c. Total column with “***** No Value*****” indicates a bid that will serve as the price for work the Town need to do at a later date, but has not indicated quantities at this time. DO NOT EXTEND these calculations. They will not calculate into the award amount, but may be used to determine the reasonableness

- d. Place the sum of the extended prices in the bold box next above in the column of extensions.
Where the extended price is in the bold box, that amount will be the basis of award.

13. MBE/WBE Participation Goals

Low bidders who accept contract awards will be required to comply with any and all Minority Business Enterprise (MBE) and Women's Business Enterprise (WBE) policies and participation goals of the Town. Bidders must submit any required MBE/WBE Forms/Letter of Intent & Schedules of Participation required by the Town to the Town for acceptance prior to beginning any scheduled work.

14. Bonds

- a. All bids must be accompanied by a Bid Bond or a certified/bank check in the amount of 5% of the estimated value of the work bid upon by a single contractor as a guarantee that the bidder will honor the bid and execute a contract with the Town, subject to forfeiture upon failure of such. ("Estimated value" equals the sum of all work bid on the basis of estimated quantities.) Bid Bonds must remain in effect for a period of not less than 60 days after the bid opening.
- b. Low bidders' bid bonds will be returned upon execution of the contract, complete with supporting documents.
- c. A Labor and Materials Bond in an amount not less than 50% of the estimated value of the contract work will be required of all bidders as part of their contracts for services.
- d. A Payment Bond in an amount not less than 50% of the estimated value of the contract work will be required of all bidders as part of their contract for services bid under M.G.L.c.30,s.39M (see Section 9 – Applicable Laws and Certifications).

15. Insurance and Indemnification

- a. Low Bidders shall be required to provide Insurance Certificates as part of the contract documents demonstrating that the following forms and limits are in effect during the term of the Contract:
-

General Liability			
<ul style="list-style-type: none"> • Comprehensive form <li style="padding-left: 20px;">Including ... <li style="padding-left: 20px;">Premises/Operations <li style="padding-left: 20px;">Underground Explosion & Collapse <li style="padding-left: 20px;">Hazard <li style="padding-left: 20px;">Independent Contractors <li style="padding-left: 20px;">Broad Form Property Damage • Products / Completed Operations • Personal Injury • Fire Damage 	Aggregate	\$2,000,000	
	Each Occurrence	\$1,000,000	
			\$2,000,000
	Aggregate	\$5,000	
	Per Person	\$50,000	
	Each Occurrence		
Automobile Liability			
<ul style="list-style-type: none"> • All Owned Vehicles • Hired Vehicles • Non-owned Vehicles 	Bodily Injury & Property Damage Combined	\$1,000,000	
Workers Compensation & Employers Liability			
<ul style="list-style-type: none"> • As Required by Commonwealth of Massachusetts 	Each Accident	\$100,000	
	Bodily Injury by Disease (Policy Limit)	\$500,000	
	Bodily Injury by Disease (Each Employee)	\$100,000	

- b. The Town of Arlington shall be named as Additional Insured and shall be provided with copies of actual policies upon request.
- c. All insurance policies shall be in force from the time of execution of the Agreement to the date when all work under the contract is completed and accepted by the Town. Contractors shall notify the Town should coverage become unavailable or if its policy should change.

- d. Certificates and any and all renewals substantiating that required insurance coverage is in effect shall be filed with the contract. Any cancellation of insurance, whether by the insurers or by the insured, shall not be valid unless written notice thereof is given by the party proposing cancellation to the other party and to the Town of Arlington at least 15 days prior to the intended effective date thereof, which date should be expressed in said notice.
 - e. Contractors shall indemnify, defend, and save harmless the Town of Arlington, and all of its officers, agents, and employees against all suits, claims of liability of every name and nature, for or on account of any injuries to persons or damaged to property arising out of the negligence of Contractors in the performance of the work covered by this Agreement and/or failure to comply with terms and conditions of this contract, whether by himself or his employees or subcontractors.
-

Section III: Terms and Conditions

16. Normal Hours of Work

- a. Normal Hours of Work shall be between the hours of 7:00 AM and 4:00 PM, Monday through Friday, unless otherwise specified. Work shall not be performed on Saturdays, Sundays, Holidays or other than during Normal Hours of Work without express authorization from the Town's Authorized Representative as identified in the Contract documents.

17. Traffic Safety

- a. Police details will be scheduled and paid for by the Town of Arlington unless otherwise specified in the bid documents.
- b. Contractors that cancel scheduled work to which police, flag people or public works personnel are assigned on an additional pay basis are subject to contract back charges for costs incurred at the discretion of the Town.

18. MBTA Right of Way Work

- a. Any contractor doing work in the right of way on the MBTA will be required to have all employees working in said zone complete an MBTA Safety Training and abide by all regulations and requirements associated with the MBTA Safety Department while working in this area.
- b. This shall include the use of flagmen and any other requirement put forth by the MBTA.
- c. All costs associated with this work shall be borne by the contractor.

19. Schedules and Deadlines

- a. Best Efforts: All parties will make their best efforts to schedule work so as to avoid undue delay and repeated postponements, and to keep costs as low as possible.
 - b. Start and Finish Work: Contractors shall be available to begin work at locations designated by the Town no later than five (5) business days from the date of execution of a Contract or on a schedule approved by the Town. Once work has been started, Contractors shall remain on the job until all scheduled work is completed to the satisfaction of the Town of Arlington.
-

- c. Assignment: Contracts may not be assigned, in whole or in part, by any Contractor without the prior written consent of the Town of Arlington.
 - d. Sub-Contracting: Contracts may not be assigned, in whole or in part, by any Contractor without the prior written consent of the Town. Contractors may sub-contract any, or all of the Town's scheduled work; however, the Contractor must inform the Town as to the name and qualifications of the selected sub contractor 72 hours prior to the work being performed and work can only proceed if the Town approves the use of the selected subcontractor. Such consent shall be considered temporary and conditional, and may be revoked at any time at the Town's discretion. If the selected sub contractor is rejected by the Town, then the Contractor must find a suitable alternative for the work at no additional cost to the Town. All standards expressed in the contract documents apply to the approved sub contractor as well. The Contractor will be responsible for the quality of the work by the sub contractor. All damages by the sub contractor will be repaired in a timely manner at no additional cost to the Town.
 - e. Presence Known to the Town: All work must be scheduled in advance and performed with the knowledge and consent of the Town. Contractors may not perform work within the Town without such knowledge and consent.
 - f. Timeliness and Approved Delays: Time shall be of the essence regarding performance of each and every portion of the contracted work. Work schedules approved by the Town shall be binding upon the Contractor except for reasonable delays due to weather, failure of the Town in the timely performance of any of its prerequisite obligations, or site-related circumstances beyond the control of the Contractor. Extensions of time resulting from such delays are subject to approval by the Town and may not be unreasonably withheld.
 - g. Postponed Work: Postponed work attributable to the Town will be rescheduled at the earliest possible date after the postponed start date, but not later than 3 weeks thereafter
 - h. Failure to Appear for Scheduled Work: In addition to the penalties noted in the preceding paragraph, Contractors that fail to appear for or cancel scheduled work to which police, flag people or public works personnel are assigned on an additional pay basis, will be subject to contract back charges for costs incurred at the discretion of the Town. Such charges may include preparation by others that is required to be repeated.
 - i. Engaging The Next Lowest Bidder: The Town of Arlington may elect, upon failure of the Low Bid Contractor to comply in a timely manner with the requirements of this section
-

(Schedules and Deadlines), to a) invoke a non-performance penalty of \$1,000 per day (deductible from rendered invoices), or b) engage the services of the next lowest bidder at his price as bid; provided that in either case the Low Bid Contractor has failed to appear and to provide the requested services within 24 hours of receipt of written notice of the Town's intentions and its basis for such action. Once this provision is exercised, the Town may, but shall not be obligated to, resume service by the Low Bid Contractor. Re-engagement of the Low Bid Contractor shall be at its Bid prices and without breach of the Contract between the Parties.

20. Legal Damages

- a. If Contractors neglect, fail or refuse to complete the work within the time herein specified, or any proper extension thereof granted by the Town of Arlington, then Contractors hereby agree, as a part consideration for the awarding of this Contract, to pay to Owner the amount of \$1,000.00 per day, not as a penalty but as liquidated damages for such breach of Contract as hereinafter set forth, for each and every calendar day that the Contract shall be in default after the time stipulated in the Contract for completing the work.
- b. The said amount is fixed and agreed upon by and between Contractors and the Town because of the impracticability and extreme difficulty of fixing and ascertaining the actual damages the Town would in such event sustain, and said amount is agreed to be the amount of damages which the Town would sustain and said amount shall be retained from time to time by the Town from current periodical estimates.

21. Termination for Cause

- a. This Contract may be terminated for cause due to unsatisfactory performance, after written warning and an opportunity for Contractors to correct the subject performance; or due to the absence of a municipal appropriation for the type of work for which the contract is made. Contractors will hold the Town harmless from all damages as a result of funding constraints. Municipal parties shall make a reasonable good faith effort to obtain sufficient additional appropriations to pay for work authorized and performed in excess of appropriations.
-

22. Invoicing & Payment

- a. With any invoice, the CONTRACTOR shall submit evidence satisfactory to the Town that the goods or services have been delivered and/or that the work has been completed in accordance with this Agreement.
 - b. Invoices shall clearly indicate quantities, hours, prices and other applicable measures that can be verified by the Town on the basis of documented inspection by the Town, or by weight, service or delivery slips provided at the time work was performed or delivery / pick-up has occurred.
 - c. Invoices shall reference the correct contract number i.e. **15-07**
 - d. Pricing shall be based on unit (or other) prices as bid. Any pricing not listed in the bid will not be honored.
 - e. Payment for services will be made on a monthly basis, thirty days after receipt of an invoice for work performed or materials supplied the previous month.
 - f. The Town of Arlington shall pay the CONTRACTOR ninety percent of the invoice. Upon satisfactory completion of the work and thirty days after receipt of an invoice for final payment, the Town shall pay the CONTRACTOR all amounts due under the Contract, including the retainage.
-

24. Miscellaneous

- a. Terms, conditions and requirements peculiar to specifications for named types of work shall supersede those contained in the "GENERAL INFORMATION" section of this IFB.
 - b. Contractors must make a diligent effort to coordinate scheduled work with the Town
 - c. Contractors shall complete all work of a continuous nature scheduled and called for by the Town prior to leaving a worksite or the municipality unless so authorized by the Town.
 - d. Contractor supervisory personnel shall be consistent for all work of a continuous nature (i.e. same job, same supervisor).
 - e. In the event the Parties loan equipment of any kind to each other, they promise to return the equipment in equal or better condition at the conclusion of use.
 - f. Where a conflict in requirements is apparent between Section A: General Terms and Conditions and the Section B: Specifications, the Specifications shall control.
-

Section IV: Forms

The following pages contain ALL FORMS that must be included with each bid. See IFB Section 10, How to Submit a Bid for more information. Please read each form, complete them accurately and make certain they are enclosed with each bid in the order in which they are listed. Contact Domenic Lanzillotti at dlanzillotti@town.arlington.ma.us or 781-316-3003 with any questions.

Form A - General Bid Form

*** Requires Bidder Response**

[ATTACH this cover sheet to each **Bid Price Form** submitted. Note .. Company name and agent's initials are required on Each Bid Price Form.]

<p>* Item(s) #: _____</p> <p>* Description: _____</p> <p>* Addenda: _____</p>
--

*** Company Name**

*** Contact Person**

*** Street**

*** Phone**

*** City, State, ZIP**

*** Fax**

*** e-mail (if any)**

Submits the attached **Bid Price Form** as its bid pertaining to the Invitation for Bids and the specific Item(s) referenced above to the **Town of Arlington** on the authority of the undersigned and as dated below. The Bidder confirms and pledges to abide by and be held to the requirements of this IFB and its resulting Contract(s), and further, to diligently and promptly perform any tasks and deliver any documents required, and to execute a Contract the Town.

*** Affix Corporate Seal ⇔**

Authorized agent of the Bidder [If a corporation, attach certificate of vote or apply corporate seal to this page.]

X _____
*** Signature**



*** Name**

*** Title**

*** Date**

Form B – Non-Collusion Statement

*** Requires Bidder Response**

Pursuant to M.G.L., Chapter 30, Section 39M, the undersigned certifies under penalties of perjury that this bid is in all respects bona fide, fair and made without collusion or fraud with any other person. As used in this paragraph, the word “person” shall mean any natural person, joint venture, partnership, corporation or other business or legal entity.

Authorized agent of the Bidder [If a corporation, attach certificate of vote or apply corporate seal to this page.]

X _____

*** Signature**

*** Name**

*** Title**

*** Date**

*** Affix Corporate Seal ⇨**



Form C – Taxes Paid Certification

*** Requires Bidder Response**

I certify, under the penalties of perjury that the below mentioned firm or person, to my best knowledge and belief, has complied with all the laws of the Commonwealth relating to taxes.

* Name [as used for business tax filing] ↓

* Business Address ↓

* Phone

* Fax

* e-mail (if any)

Authorized agent of the Bidder [If a corporation, attach certificate of vote or apply corporate seal.]

X _____

* Signature

* Affix Corporate Seal ⇔



* Name

* Title

* Date

* Social Security # or Federal Identification #

Approval of a contract or other agreement will not be granted unless the applicant signs this certification form.

Your Social Security Number or Federal Identification Number will be furnished to the Massachusetts Department of Revenue (DOR) to determine whether you have met tax filing or tax payment obligations. The Town is required to furnish a list to the DOR at the end of its fiscal year, showing the vendors to whom more than \$5,000 is paid during the 12 months ending June 30. Providers who fail to correct their non-filing or delinquency will not have a contract or other agreement issued, renewed, or extended. This request is made under the authority of Massachusetts General Laws, Chapter 62C, Section 49a, Certification Clause.

OSHA TRAINING

The undersigned hereby certifies that it is able to furnish labor that can work in harmony with all other elements of labor employed or to be employed on the work; that all employees to be employed at the worksite will have successfully completed a course in construction safety and health approved by the United States Occupational Safety and Health Administration that is at least 10 hours in duration at the time the employee begins work and who shall furnish documentation of successful completion of said course with the first certified payroll report for each employee; and that it will comply fully with all laws and regulations applicable to awards made subject to section forty-four A of Chapter 149 of the General Laws.

Signature: _____

Title: _____

Date: _____

Form D – Contract

The following pages contain the general contract. It will be combined with the content of Bid #15-07 (the IFB Document), relevant specifications and Bid Price Forms, and the required bonds and certificates to be provided by the Contractor.

CONTRACT NO.
AGREEMENT

THIS AGREEMENT, made as of this ____ day of _____, 20__ by and between the TOWN OF ARLINGTON, MASSACHUSETTS, acting through its TOWN MANAGER, hereinafter called the "Owner", and _____ of _____, hereinafter called the "Contractor".

WITNESSETH: That the Contractor and the Owner for the consideration hereinafter Named agrees as follows:

1. SCOPE: The Contractor will furnish at his own proper cost and expense all materials, supplies, machinery, equipment, appliances, accessories, tools, superintendence, labor, insurance and other items and services necessary to complete the work as shown and described on the Contract Documents entitled "_____", Arlington, Massachusetts", hereinafter called the "Project", prepared by _____, hereinafter called the "Designer", or "Landscape Architect".

2. CONTRACT SUM: The Owner agrees to pay the Contractor, and the Contractor agrees to accept in full consideration for the performance of the contract, subject to additions and deductions provided for in the contract documents, in current funds, the sum of ____, hereinafter called the "Contract Sum" and to make payments on account thereof, as described below and elsewhere in the Contract Documents.

3. COMMENCEMENT OF WORK AND TIME OF COMPLETION: The Contractor agrees to commence work on the contract on or about _____. He agrees to complete the Project on or before _____.

4. LIQUIDATED DAMAGES: The Contractor agrees to pay the Owner liquidated damages for failure to complete the project in conformance with the time allowances as set forth above at the rate of _____ per calendar day.

5. ALTERNATES: The following Alternates have been accepted and the Contract Sum stated in paragraph 2 of this Agreement includes and is adjusted to reflect the Total cost of each accepted alternate:

Add Alternate No. Indicate Accepted or Rejected Original Bid Value of Alternate

Add Alternate No. 1

Add Alternate No. 2

Deduct Alternate No.

(this space intentionally left blank)

6. PAYMENTS TO CONTRACTOR: Payments shall be made in accordance with Chapter 30, Section 39K of the General Laws of the Commonwealth of Massachusetts, including all current amendments, generally as follows:

- A. Within fifteen days after receipt from the Contractor, at the place designated by the Owner if such a place is so designated, of a period estimate requesting payment of the amount due for the preceding month, The Owner will make a periodic payment to the contractor for the work performed during the preceding month and for the materials not incorporated in the work but delivered and suitably stored at the site (or at some location agreed upon in writing) to which the Contractor has title or to which a subcontractor has title and has authorized to Contractor to transfer title to the Owner, less (1) a retention based an its estimate of the fair value of its claims against the Contractor and less (2) a retention for direct payments to subcontractors based on demands for same in accordance with the provisions of Section 39F, and less (3) a retention not exceeding five percent of the approved amount of the periodic payment. After the receipt of a periodic estimate requesting final payment and within sixty-five days after (a) The Contractor fully completes the work or substantial completes the work so that the value of the work remaining to be done is, in the estimate of the Owner, less than one percent of the original contract price or (b) the Contractor substantially completes the work and the Owner takes possession for occupancy, whichever occurs first, the Owner shall pay the Contractor the entire balance due on the contract less (1) a retention based on its estimate the fair value of its claim against the Contractor and of the cost of the completing the incomplete and unsatisfactory items of work and less (2) a retention for direct payments to subcontractors based on the demands for same in accordance with the provisions of Section 39F, or based on the record of payments by the Contractor to the subcontractors under this contract if such record of payment indicates that the Contractor has not paid subcontractors as provided in Section 39F. If the Owner fails to make payment as herein provided, there shall be added to each such payment daily interest at the rate of five percent per annum commencing on the first day after said payment is due

and continuing until the payment is delivered or mailed to the Contractor; provided that no interest shall be due, in any event, on the amount due on a periodic estimate for Final Payment until fifteen days after receipt of such a periodic estimate from the Contractor, at the place designated by the Owner if such a place is so designated. The Contractor agrees to pay to each subcontractor a portion of any such interest paid in accordance with the amount due each subcontractor.

- B. The Owner may make changes in any periodic estimate submitted by the Contractor and the payment due on said periodic estimate shall be computed in accordance with the changes so made, but such changes or any requirement for a corrected periodic estimate shall not effect the due date for the periodic payment or the date for the commencement of interest charges on the amount of the periodic payment computed in accordance with the changes made, as provided herein; provided that the Owner may, within seven days after receipt, return to the Contractor for correction any periodic estimate which is not in the required form or which contains computations not arithmetically correct and, in that event, the date of receipt for such periodic estimate in proper form and with arithmetically correct computations. The date of receipt of a periodic estimate received on a Saturday shall be the first working day thereafter. The provisions of Section 39G shall not apply to any contract for the construction, reconstruction, remodeling, repair or demolition of any public building to which this section applies.

7. PAYMENTS TO SUBCONTRACTORS: Payments shall be made in accordance with Chapter 30, Section 39F of the General Laws of the Commonwealth of Massachusetts, including all current amendments, generally as follows:

- A. Forthwith after the General Contractor receives payment on account of a period estimate, the General Contractor shall pay to each Subcontractor the amount paid for the labor performed and the materials furnished in any court proceedings barring such payment and also less any amount claimed due from the Subcontractor by the General Contractor.
- B. Not later than the sixty-fifth day after each Subcontractor substantially completes his work in accordance with the plans and specifications, the entire balance due under the subcontract less amounts retained by the Owner as the estimated cost of completing the incomplete and unsatisfactory items of work, shall be due the Subcontractor; and the Owner shall pay that amount to the General Contractor. The General Contractor shall forthwith pay to the Subcontractor the full amount received from the Owner less any amount specified in any court proceedings barring such payment and also less any amount claimed due from the Subcontractor by the General Contractor.
- C. Each payment made by the Owner to the General Contractor pursuant to subparagraphs (A) and (B) of this paragraph for the labor performed and the materials furnished by a Subcontractor shall be made to the General Contractor for the account of that Subcontractor; and the Owner shall take reasonable steps to compel the General Contractor to make each payment to each such Subcontractor. If the Owner has received a demand for direct payment from a Subcontractor for any amount which has already been included in a payment to the General Contractor for payment to the Subcontractor as provided in subparagraphs (A) and (B), the Owner shall act upon demand as provided in this Section.

- D. If, within seventy days after the Subcontractor has substantially completed the Subcontract work, the Subcontractor has not received from the General Contractor the balance due under the Subcontract including any amount due for extra labor and materials furnished to the General Contractor, less any amount retained by the Owner as the estimated cost of completing the incomplete and unsatisfactory items of work, the Subcontractor may demand direct payment of that balance from the Owner. The demand shall be by a sworn statement delivered to or sent by certified mail to the Owner, and a copy shall be delivered to or sent by certified mail to the General Contractor at the same time. The demand shall contain a detailed breakdown of the balance due under the Subcontract and also a statement of the status of completion of the Subcontract work. Any demand made after Substantial Completion of the Subcontract work shall be valid even if delivered or mailed prior to the seventieth day after the Subcontractor has substantially completed the Subcontract work. Within ten days after the Subcontractor has delivered or so mailed the demand to the Owner and delivered or so mailed a copy to the General Contractor, the General Contractor may reply to the demand. The reply shall be a sworn statement delivered to or sent by certified mail to the Owner and a copy shall be delivered to or sent by certified mail to the Subcontractor at the same time. The reply shall contain a detailed breakdown of the balance due under the Subcontract including any amount due for extra labor and materials furnished to the General Contractor and of the amount due for each claim made by the General Contractor against the Subcontractor.
- E. Within fifteen days after receipt of the demand by the Owner, but in no event prior to the seventieth day after Substantial Completion of the Subcontract work, the Awarding Authority shall make direct payment to the Subcontractor of the balance due under the Subcontract, less any amount (i) retained by the Owner as the estimated cost of completing the incomplete or unsatisfactory items of work, (ii) specified in any court proceedings barring such payment, or (iii) disputed by the General Contractor in the sworn reply; provided, that the Owner shall not deduct from a direct payment any amount as provided in part (iii) if the reply is not sworn to, or for which the sworn reply does not contain the detailed breakdown required in subparagraph (D). The Owner shall make further direct payments to the Subcontractor forthwith after the removal of the basis for deductions from direct payments made as provided in parts (i) and (ii) of this subparagraph.
- F. The Owner shall forthwith deposit the amount deducted from a direct payment as provided in part (iii) of subparagraph (E) in an interest bearing joint account in the names of the General Contractor and the Subcontractor in a bank in Massachusetts selected by the Owner and agreed upon by the General Contractor and the Subcontractor and shall notify the General Contractor and the Subcontractor of the date of deposit and the bank receiving the deposit. The bank shall pay the amount on the account, including accrued interest, as provided in an agreement between the General Contractor and the Subcontractor or as determined by decree of a court of competent jurisdiction.
- G. All direct payments and all deductions from demands for direct payments deposited in an interest bearing account or accounts in a bank pursuant to subparagraph (F) shall be made out of amounts payable to the General Contractor at the time of receipt of a demand for direct payment from a Subcontractor and out of amounts which later become payable to the General Contractor and in order of receipt of

Such demands from Subcontractors. All direct payments shall discharge the Obligation of the Owner to the General Contractor to the extent of such payment.

- H. The Owner shall deduct from payments to a General Contractor amounts which, together with the deposits in interest-bearing accounts pursuant to subparagraph (F), are sufficient to satisfy all unpaid balances of demands for direct payments received from Subcontractors. All such amounts shall be earmarked for such direct payments, and the Subcontractors shall have a right in such deductions prior to any claims against such amounts by creditors of the General Contractor.
- I. On all contracts for building construction subject to the provisions of Sections 44A to 44L, inclusive, of Chapter 149, periodic payments for work performed by a Subcontractor shall be made to the General contractor for payment to the Subcontractor and shall be paid to the Subcontractor forthwith after receipt thereof by the General Contractor and without any ten-day waiting period as provided above, less any amount claimed by the General Contractor in a letter containing a breakdown of the claim and sent to the Subcontractor with such payment, provided that a General Contractor, who has received a periodic estimate for a periodic payment in proper form from a Subcontractor three days, Saturdays, Sundays and holidays excluded, before the due date of the General Contractor's periodic estimate for the same periodic payment period less any amount claimed by the General Contractor in a letter containing a breakdown of the claim and sent to the Subcontractor with such payment, even though the General contractor does not submit a periodic estimate to the Owner for that payment period; and provided, further, that the Owner shall take all reasonable steps to compel the General Contractor to make payment to the Subcontractors as provided in this paragraph, and upon the written request of a Subcontractor setting forth the amount payable but not paid, a copy of which shall be sent to the General Contractor, shall make direct payment to a Subcontractor, as provided for above, which shall discharge the obligation of the Owner to the General Contractor to the extent of any such payment.
- J. The Owner shall not include in any direct payment made to a Subcontractor pursuant to this section any amount claimed from that Subcontractor by the General Contractor in a letter containing a breakdown of the claim and sent to the Owner within ten days after the receipt by the General Contractor of the copy of the request of the Subcontractor to the Owner for direct payment

8. CONDITIONS OF EMPLOYMENT

- A. The schedule of Minimum Wage Rates and Health and Welfare and Pension Fund Contributions as determined by the Commissioner under the provisions of the Massachusetts General Laws, Chapter 149, Sections 26 to 27D, inclusive, as amended, is hereby made a part of this agreement.
- B. The Contractor shall pay to any reserve police officer employed by him in any city or town the prevailing rate of wages paid to regular police officers in such city or town.
- C. No laborer, workman, mechanic, foreman or inspector working within the Commonwealth, in the employ of the Contractor, Subcontractor or any other Person doing or contracting to do the whole or a part of the work contemplated by

The Contract, shall be required or permitted to work more than eight hours in any one day or forty-eight hours in any one week, or more than six days in any one week, except in cases of emergency.

- D. Every employee of the Contractor or any Subcontractor shall lodge, board and trade where and with whom he elects; and no person or his agents or employees shall be directly or indirectly required, as a condition of employment that the employee to lodge, board or trade at a particular place or with a particular person.

9. SUBCONTRACTORS

- A. The Contractor will employ the following Subcontractors on the work and will Pay for the execution of his as defined in the Contract Documents; and subject to The additions and deductions provided in the subject to the additions and Deductions provided in the Contract Documents, the sum shown opposite his Name.

<u>Class of Work</u>	<u>Subcontractor</u>	<u>Subcontractor Sum</u>

- B. The names of any individual Subcontractors whom the Contractor proposed to Employ shall be submitted to the Designer for approval. No such Subcontractor Shall be employed to whose standing or ability the Owner or the Designer has any Reasonable objection.

10. THE CONTRACT DOCUMENTS: The General Conditions of the Contract, the Specifications and the Drawings, together with this Agreement, for the Contract, and they Are as fully a part of the Contract as if hereto attached or herein repeated. Drawings and Specifications titled:

11. INCORPORATION OF STATUTES BY REFERENCE: If statutes of the Commonwealth of Massachusetts in any way relating to the construction, alterations, repair and installation of public works, particularly with reference to labor and labor rates, they shall be strictly complied with by the Contractor and it is understood that all such statutes are incorporated by reference in this Contract.

12. It is expressly agreed that this Agreement is to be executed for and in behalf of the Owner by the members of its Board of Selectmen and any of its appoints and that Such persons are acting in a representative capacity for and in behalf of Owner; and That such persons shall not incur any personal liability hereunder.

IN WITNESS whereof, inhabitants of the Town of Arlington and

Have caused these presents to be executed by their

Hereunto duly authorized the day and year first written

TOWN OF ARLINGTON

Adam W. Chapdelaine, Town Manager

Contractor

By: _____

(Name/Title)

Approved as to Matter of Form:

Juliana deHaan Rice, Town Counsel

Certification: I hereby certify that an Appropriation in the amount of the Contract is available.

Ruth Lewis, Comptroller

PERFORMANCE BOND

KNOW ALL MEN BY THESE PRESENTS: That we

(Name of Contractor)

a

(Corporation, Partnership or Individual)

hereinafter called "Principal" and

(Surety)

of _____, State of _____, hereinafter

called the "Surety", are held and firmly bound into

THE TOWN OF ARLINGTON, MASSACHUSETTS

(Owner)

acting through its TOWN MANAGER

ARLINGTON, MASSACHUSETTS

(City and State)

hereinafter called "Owner", in the penal sum of

_____ Dollars (\$ _____)

in lawful money of the United States, for the payment of which sum well and truly to be made, we bind ourselves, our heirs, executors, administrators and successors, jointly and severally, firmly by these presents.

THE CONDITION OF THIS OBLIGATION is such that Whereas, the Principal entered into a certain contract with the Owner, dated _____ day of _____ 19____, a copy of which is hereto attached and made a part hereof for the construction of

Arlington, Massachusetts

NOW, THEREFORE, if the Principal shall well, truly and faithfully perform its duties, all the undertakings, covenants, terms, conditions, and agreements of said Contract during the original term thereof, and any extensions thereof which may be granted by the Owner, with or without notice to the Surety, and if he shall satisfy all claims and demands incurred under such contract, and shall fully indemnify and save harmless the Owner from all costs

and damages which it may suffer by reason of failure to do so, and shall reimburse and repay the Owner all outlay and expense which the Owner may incur in making good any default, then this obligation shall be void; otherwise to remain in full force and effect.

PROVIDED, FURTHER, that the said Surety, for value received hereby stipulates and agrees that no change, extension of time, alteration or addition to the terms of the Contract or to the work to be performed thereunder or the specifications accompanying the same shall in any way affect its obligation of this Bond, and it does hereby waive notice of any such change, extension of time, alteration or addition to the terms of the contract or to the work or to the specifications.

PROVIDED, FURTHER, that no final settlement between the Owner and the Contractor shall abridge the right of any beneficiary hereunder, whose claim may be unsatisfied.

IN WITNESS WHEREOF, the parties to these present have duly executed in this Bond on the day of _____, 19__.

ATTEST:

Principal

By _____
Secretary

(Address-Zip Code)

Witness as to Principal

(SEAL)

(Address-Zip Code)

ATTEST:

Surety

BY _____
(Surety)

Secretary

(Address-Zip Code)

Witness as to Surety

(SEAL)

(Address-Zip Code)

NOTE: Date of Bond must not be prior to date of Contract. If Contractor is a Partnership, all partners should execute Bond.

END OF DOCUMENT

LABOR AND MATERIALS PAYMENT BOND

KNOW ALL MEN BY THESE PRESENTS: That we

(Name of Contractor)

a _____

(Corporation, Partnership or Individual)

hereinafter called "Principal" and

(Surety)

of _____, State of _____, hereinafter called the "Surety", are held and firmly bound into

TOWN OF ARLINGTON, MASSACHUSETTS

(Owner)

acting through its TOWN MANAGER

ARLINGTON, MASSACHUSETTS

(City and State)

herein called "Owner", in the penal sum of

_____ Dollars (\$_____)

in lawful money of the United States, for the payment of which sum well and truly to be made, we bind ourselves, our heirs, executors, administrators and successors, jointly and severally, firmly by these presents.

THE CONDITION OF THIS OBLIGATION is such that Whereas, the Principal entered into a certain contract with the Owner, dated the day of _____, 19____, a copy of which is hereto attached and made a part hereof for the construction of:

ARLINGTON, MASSACHUSETTS

NOW, THEREFORE, if the Principal shall promptly make payment to all persons, firms, subcontractors, and corporations furnishing materials for or performing labor in the prosecution of the work provided for in such contract, and any authorized extension or modification thereof, including all amounts due for materials, lubricants, oil, gasoline, coal and coke, repairs on machinery, equipment and tools, consumed or used in connection with the construction of such work, and all insurance premiums on said work, and for all labor, performed in such work whether by subcontractor or otherwise, then this obligation shall be void; otherwise to remain in full force and effect.

PROVIDED, FURTHER, that the said Surety, for value received hereby stipulates and agrees that no change, extension of time, alteration or addition to the terms of the contract or to the work to be performed thereunder or the specifications accompanying the same shall in any wise affect its obligation on this Bond, and it does hereby waive notice of any such change, extension of time, alteration or addition to the terms of the contract or to the work or to the specifications.

PROVIDED, FURTHER, that no final settlement between the Owner and the Contractor shall abridge the right of any beneficiary hereunder, whose claim may be unsatisfied.

IN WITNESS WHEREOF, the parties to these present have duly executed in this Bond on the day of _____ 19__.

ATTEST:

Principal

By _____
Secretary

(Address-Zip Code)

Witness as to Principal

(SEAL)

(Address-Zip Code)

ATTEST:

Surety

Secretary

(Address-Zip Code)

Witness as to Surety

(SEAL)

(Address-Zip Code)

NOTE: Date of Bond must not be prior to date of Contract. If Contractor is a Partnership, all partners should execute Bond.

END OF DOCUMENT

Appendix A – List of Bid Documents

List of Bid Documents

The following documents apply to this IFB:

- | | |
|--------------------|---|
| I. Doc # 00 | INVITATION FOR BIDS |
| II. | SPECIFICATIONS & BID PRICE FORMS |
| III. | PREVAILING WAGES |
| | |
| | |
-

Appendix B – Prevailing Wage Rates

Prevailing Wage information, reporting forms and applicable hourly rates are incorporated into a separate document. It will accompany **6X.0** \$+ when sent to bidders.

IMPORTANT! All payroll reporting required by law will be carried out between the Town of Arlington and Contractors.

From: "MA Prevailing Wage" <prevailingwages@state.ma.us>
To: dlanzillotti@town.arlington.ma.us
Date: 06/02/2015 03:12 PM
Subject: Prevailing wage schedule for Wage Request number :20150602-070

To view and print Weekly Payroll & Statement of Compliance Forms, click on www.mass.gov/dols/pw.

PLEASE NOTE: The attached Prevailing Wage Schedule is valid for 90 days. An Awarding Authority should re-request an up to date Prevailing Wage Schedule if it has NOT opened bids or selected a contractor within 90 days of the issuance date of the attached prevailing wage schedule.

*For MULTI-YEAR projects bid on or after 8/8/08, Awarding Authorities must request an Annual Update to this Prevailing Wage Schedule each year for the duration of the project, no later than two weeks before the anniversary date of the execution of the general contract. Annual updates are not required for projects that last LESS THAN ONE YEAR.

*For CM AT RISK projects (bid pursuant to GL c.149A), Awarding Authorities must request a Prevailing Wage Schedule NOT sooner than 90-days before the earlier of: (a) the execution date of the GMP Amendment, or (b) the bid for the first construction scope of work.

*For MULTI-YEAR CM AT RISK projects, Awarding Authorities must request an Annual Update to this Prevailing Wage Schedule each year for the duration of the project, no later than two weeks before the anniversary date, which is the earlier of: (a) the execution date of the GMP Amendment, or (b) the execution date of the first amendment to procure construction scopes of work.

Apprentice wages (expressed as dollar figures) and the required benefits are listed on the Prevailing Wage Schedule. For further details, please see opinion letter PW-2010-03-03.16.10 (dated March 18, 2010) at www.mass.gov/dols/pw.

Request Prevailing Wage Rates online at: www.mass.gov/dols/pw.

THIS IS A SYSTEM-GENERATED EMAIL. PLEASE DO NOT REPLY TO THIS EMAIL.
TO CONTACT DLS REGARDING PREVAILING WAGE MATTERS, CALL 617-626-6953.

APPROVAL/DENIAL COMMENTS

This e-mail message, including any attachments, is for the sole use of the intended recipient(s) and may contain confidential and privileged information. Any unauthorized review, use, disclosure, or distribution is strictly prohibited and may be the subject of legal action. If you are not the intended recipient, please contact the sender by reply

e-mail and destroy all copies of the original message. Thank you.

Attachments:

File: 20150602-070.pdf Size: 168k Content Type: application/pdf



**THE COMMONWEALTH OF MASSACHUSETTS
EXECUTIVE OFFICE OF LABOR AND WORKFORCE DEVELOPMENT
DEPARTMENT OF LABOR STANDARDS**

Prevailing Wage Rates

**As determined by the Director under the provisions of the
Massachusetts General Laws, Chapter 149, Sections 26 to 27H**

CHARLES D. BAKER
Governor

KARYN E. POLITO
Lt. Governor

RONALD L. WALKER, II
Secretary

JEAN ZEILER
Acting Director

Awarding Authority: Town of Arlington
Contract Number: 15-07 **City/Town:** ARLINGTON
Description of Work: 1 year contract to pave, reconstruct streets, curb, sidewalks and related work as required.
Job Location: Various

Information about Prevailing Wage Schedules for Awarding Authorities and Contractors

- This wage schedule applies only to the specific project referenced at the top of this page and uniquely identified by the “Wage Request Number” on all pages of this schedule.
- An Awarding Authority must request an updated wage schedule from the Department of Labor Standards (“DLS”) if it has not opened bids or selected a contractor within 90 days of the date of issuance of the wage schedule. For CM AT RISK projects (bid pursuant to G.L. c.149A), the earlier of: (a) the execution date of the GMP Amendment, or (b) the bid for the first construction scope of work must be within 90-days of the wage schedule issuance date.
- The wage schedule shall be incorporated in any advertisement or call for bids for the project as required by M.G.L. c. 149, § 27. The wage schedule shall be made a part of the contract awarded for the project. The wage schedule must be posted in a conspicuous place at the work site for the life of the project in accordance with M.G.L. c. 149 § 27. The wages listed on the wage schedule must be paid to employees performing construction work on the project whether they are employed by the prime contractor, a filed sub-bidder, or any sub-contractor.
- All apprentices working on the project are required to be registered with the Massachusetts Division of Apprentice Standards (DAS). Apprentice must keep his/her apprentice identification card on his/her person during all work hours on the project. An apprentice registered with DAS may be paid the lower apprentice wage rate at the applicable step as provided on the prevailing wage schedule. **If an apprentice rate is not listed on the prevailing wage schedule for the trade in which an apprentice is registered with the DAS, the apprentice must be paid the journeyworker's rate for the trade.**
- The wage rates will remain in effect for the duration of the project, except in the case of multi-year public construction projects. For construction projects lasting longer than one year, awarding authorities must request an updated wage schedule. Awarding authorities are required to request these updates no later than two weeks before the anniversary of the date the contract was executed by the awarding authority and the general contractor. For multi-year CM AT RISK projects, awarding authority must request an annual update no later than two weeks before the anniversary date, determined as the earlier of: (a) the execution date of the GMP Amendment, or (b) the execution date of the first amendment to permit procurement of construction services. Contractors are required to obtain the wage schedules from awarding authorities, and to pay no less than these rates to covered workers. The annual update requirement is not applicable to 27F “rental of equipment” contracts.
- Every contractor or subcontractor which performs construction work on the project is required to submit weekly payroll reports and a Statement of Compliance directly to the awarding authority by mail or email and keep them on file for three years. Each weekly payroll report must contain: the employee’s name, address, occupational classification, hours worked, and wages paid. Do not submit weekly payroll reports to DLS. A sample of a payroll reporting form may be obtained at <http://www.mass.gov/dols/pw>.
- Contractors with questions about the wage rates or classifications included on the wage schedule have an affirmative obligation to inquire with DLS at (617) 626-6953.
- Employees not receiving the prevailing wage rate set forth on the wage schedule may report the violation to the Fair Labor Division of the office of the Attorney General at (617) 727-3465.
- Failure of a contractor or subcontractor to pay the prevailing wage rates listed on the wage schedule to all employees who perform construction work on the project is a violation of the law and subjects the contractor or subcontractor to civil and criminal penalties.

Classification	Effective Date	Base Wage	Health	Pension	Supplemental Unemployment	Total Rate
Construction						
(2 AXLE) DRIVER - EQUIPMENT <i>TEAMSTERS JOINT COUNCIL NO. 10 ZONE A</i>	06/01/2015	\$32.75	\$9.91	\$9.33	\$0.00	\$51.99
	08/01/2015	\$32.75	\$10.41	\$9.33	\$0.00	\$52.49
	12/01/2015	\$32.75	\$10.41	\$10.08	\$0.00	\$53.24
	06/01/2016	\$33.25	\$10.41	\$10.08	\$0.00	\$53.74
	08/01/2016	\$33.25	\$10.91	\$10.08	\$0.00	\$54.24
	12/01/2016	\$33.25	\$10.91	\$10.89	\$0.00	\$55.05
(3 AXLE) DRIVER - EQUIPMENT <i>TEAMSTERS JOINT COUNCIL NO. 10 ZONE A</i>	06/01/2015	\$32.82	\$9.91	\$9.33	\$0.00	\$52.06
	08/01/2015	\$32.82	\$10.41	\$9.33	\$0.00	\$52.56
	12/01/2015	\$32.82	\$10.41	\$10.08	\$0.00	\$53.31
	06/01/2016	\$33.32	\$10.41	\$10.08	\$0.00	\$53.81
	08/01/2016	\$33.32	\$10.91	\$10.08	\$0.00	\$54.31
	12/01/2016	\$33.32	\$10.91	\$10.89	\$0.00	\$55.12
(4 & 5 AXLE) DRIVER - EQUIPMENT <i>TEAMSTERS JOINT COUNCIL NO. 10 ZONE A</i>	06/01/2015	\$32.94	\$9.91	\$9.33	\$0.00	\$52.18
	08/01/2015	\$32.94	\$10.41	\$9.33	\$0.00	\$52.68
	12/01/2015	\$32.94	\$10.41	\$10.08	\$0.00	\$53.43
	06/01/2016	\$33.44	\$10.41	\$10.08	\$0.00	\$53.93
	08/01/2016	\$33.44	\$10.91	\$10.08	\$0.00	\$54.43
	12/01/2016	\$33.44	\$10.91	\$10.89	\$0.00	\$55.24
ADS/SUBMERSIBLE PILOT <i>PILE DRIVER LOCAL 56 (ZONE 1)</i>	08/01/2014	\$87.36	\$9.80	\$18.17	\$0.00	\$115.33
	08/01/2015	\$90.51	\$9.80	\$18.17	\$0.00	\$118.48
AIR TRACK OPERATOR <i>LABORERS - ZONE 1</i>	06/01/2015	\$36.10	\$7.30	\$12.95	\$0.00	\$56.35
	12/01/2015	\$36.85	\$7.30	\$12.95	\$0.00	\$57.10
	06/01/2016	\$37.60	\$7.30	\$12.95	\$0.00	\$57.85
	12/01/2016	\$38.60	\$7.30	\$12.95	\$0.00	\$58.85
For apprentice rates see "Apprentice- LABORER"						
ASBESTOS REMOVER - PIPE / MECH. EQUIPT. <i>HEAT & FROST INSULATORS LOCAL 6 (BOSTON)</i>	06/01/2015	\$33.43	\$10.40	\$5.95	\$0.00	\$49.78
	12/01/2015	\$34.38	\$10.40	\$5.95	\$0.00	\$50.73
ASPHALT RAKER <i>LABORERS - ZONE 1</i>	06/01/2015	\$35.60	\$7.30	\$12.95	\$0.00	\$55.85
	12/01/2015	\$36.35	\$7.30	\$12.95	\$0.00	\$56.60
	06/01/2016	\$37.10	\$7.30	\$12.95	\$0.00	\$57.35
	12/01/2016	\$38.10	\$7.30	\$12.95	\$0.00	\$58.35
For apprentice rates see "Apprentice- LABORER"						
ASPHALT/CONCRETE/CRUSHER PLANT-ON SITE <i>OPERATING ENGINEERS LOCAL 4</i>	06/01/2015	\$42.83	\$10.00	\$14.55	\$0.00	\$67.38
	12/01/2015	\$44.08	\$10.00	\$14.55	\$0.00	\$68.63
	06/01/2016	\$44.83	\$10.00	\$14.55	\$0.00	\$69.38
	12/01/2016	\$46.08	\$10.00	\$14.55	\$0.00	\$70.63
	06/01/2017	\$47.08	\$10.00	\$14.55	\$0.00	\$71.63
	12/01/2017	\$48.08	\$10.00	\$14.55	\$0.00	\$72.63
For apprentice rates see "Apprentice- OPERATING ENGINEERS"						
BACKHOE/FRONT-END LOADER <i>OPERATING ENGINEERS LOCAL 4</i>	06/01/2015	\$42.83	\$10.00	\$14.55	\$0.00	\$67.38
	12/01/2015	\$44.08	\$10.00	\$14.55	\$0.00	\$68.63
	06/01/2016	\$44.83	\$10.00	\$14.55	\$0.00	\$69.38
	12/01/2016	\$46.08	\$10.00	\$14.55	\$0.00	\$70.63
	06/01/2017	\$47.08	\$10.00	\$14.55	\$0.00	\$71.63
	12/01/2017	\$48.08	\$10.00	\$14.55	\$0.00	\$72.63

Classification	Effective Date	Base Wage	Health	Pension	Supplemental Unemployment	Total Rate
For apprentice rates see "Apprentice- OPERATING ENGINEERS"						
BARCO-TYPE JUMPING TAMPER <i>LABORERS - ZONE 1</i>	06/01/2015	\$35.60	\$7.30	\$12.95	\$0.00	\$55.85
	12/01/2015	\$36.35	\$7.30	\$12.95	\$0.00	\$56.60
	06/01/2016	\$37.10	\$7.30	\$12.95	\$0.00	\$57.35
	12/01/2016	\$38.10	\$7.30	\$12.95	\$0.00	\$58.35
For apprentice rates see "Apprentice- LABORER"						
BLOCK PAVER, RAMMER / CURB SETTER <i>LABORERS - ZONE 1</i>	06/01/2015	\$36.10	\$7.30	\$12.95	\$0.00	\$56.35
	12/01/2015	\$36.85	\$7.30	\$12.95	\$0.00	\$57.10
	06/01/2016	\$37.60	\$7.30	\$12.95	\$0.00	\$57.85
	12/01/2016	\$38.60	\$7.30	\$12.95	\$0.00	\$58.85
For apprentice rates see "Apprentice- LABORER"						
BOILER MAKER <i>BOILERMAKERS LOCAL 29</i>	01/01/2010	\$37.70	\$6.97	\$11.18	\$0.00	\$55.85

Apprentice - BOILERMAKER - Local 29

Effective Date - 01/01/2010

Step	percent	Apprentice Base Wage	Health	Pension	Supplemental Unemployment	Total Rate
1	65	\$24.51	\$6.97	\$11.18	\$0.00	\$42.66
2	65	\$24.51	\$6.97	\$11.18	\$0.00	\$42.66
3	70	\$26.39	\$6.97	\$11.18	\$0.00	\$44.54
4	75	\$28.28	\$6.97	\$11.18	\$0.00	\$46.43
5	80	\$30.16	\$6.97	\$11.18	\$0.00	\$48.31
6	85	\$32.05	\$6.97	\$11.18	\$0.00	\$50.20
7	90	\$33.93	\$6.97	\$11.18	\$0.00	\$52.08
8	95	\$35.82	\$6.97	\$11.18	\$0.00	\$53.97

Notes:

Apprentice to Journeyworker Ratio:1:5

BRICK/STONE/ARTIFICIAL MASONRY (INCL. MASONRY WATERPROOFING) <i>BRICKLAYERS LOCAL 3 (BOSTON)</i>	02/01/2015	\$48.96	\$10.18	\$18.50	\$0.00	\$77.64
	08/01/2015	\$49.86	\$10.18	\$18.57	\$0.00	\$78.61
	02/01/2016	\$50.43	\$10.18	\$18.57	\$0.00	\$79.18
	08/01/2016	\$51.33	\$10.18	\$18.65	\$0.00	\$80.16
	02/01/2017	\$51.90	\$10.18	\$18.65	\$0.00	\$80.73

Classification

Effective Date Base Wage Health Pension Supplemental Unemployment Total Rate

Apprentice - BRICK/PLASTER/CEMENT MASON - Local 3 Boston

Effective Date - 02/01/2015

Step	percent	Apprentice Base Wage	Health	Pension	Supplemental Unemployment	Total Rate
1	50	\$24.48	\$10.18	\$18.50	\$0.00	\$53.16
2	60	\$29.38	\$10.18	\$18.50	\$0.00	\$58.06
3	70	\$34.27	\$10.18	\$18.50	\$0.00	\$62.95
4	80	\$39.17	\$10.18	\$18.50	\$0.00	\$67.85
5	90	\$44.06	\$10.18	\$18.50	\$0.00	\$72.74

Effective Date - 08/01/2015

Step	percent	Apprentice Base Wage	Health	Pension	Supplemental Unemployment	Total Rate
1	50	\$24.93	\$10.18	\$18.57	\$0.00	\$53.68
2	60	\$29.92	\$10.18	\$18.57	\$0.00	\$58.67
3	70	\$34.90	\$10.18	\$18.57	\$0.00	\$63.65
4	80	\$39.89	\$10.18	\$18.57	\$0.00	\$68.64
5	90	\$44.87	\$10.18	\$18.57	\$0.00	\$73.62

Notes:

Apprentice to Journeyworker Ratio:1:5

BULLDOZER/GRADER/SCRAPER <i>OPERATING ENGINEERS LOCAL 4</i>	06/01/2015	\$42.42	\$10.00	\$14.55	\$0.00	\$66.97
	12/01/2015	\$43.66	\$10.00	\$14.55	\$0.00	\$68.21
	06/01/2016	\$44.41	\$10.00	\$14.55	\$0.00	\$68.96
	12/01/2016	\$45.64	\$10.00	\$14.55	\$0.00	\$70.19
	06/01/2017	\$46.63	\$10.00	\$14.55	\$0.00	\$71.18
	12/01/2017	\$47.62	\$10.00	\$14.55	\$0.00	\$72.17
For apprentice rates see "Apprentice- OPERATING ENGINEERS"						
CAISSON & UNDERPINNING BOTTOM MAN <i>LABORERS - FOUNDATION AND MARINE</i>	06/01/2015	\$36.45	\$7.30	\$13.15	\$0.00	\$56.90
	12/01/2015	\$37.20	\$7.30	\$13.15	\$0.00	\$57.65
	06/01/2016	\$37.95	\$7.30	\$13.15	\$0.00	\$58.40
	12/01/2016	\$38.95	\$7.30	\$13.15	\$0.00	\$59.40
For apprentice rates see "Apprentice- LABORER"						
CAISSON & UNDERPINNING LABORER <i>LABORERS - FOUNDATION AND MARINE</i>	06/01/2015	\$35.30	\$7.30	\$13.15	\$0.00	\$55.75
	12/01/2015	\$36.05	\$7.30	\$13.15	\$0.00	\$56.50
	06/01/2016	\$36.80	\$7.30	\$13.15	\$0.00	\$57.25
	12/01/2016	\$37.80	\$7.30	\$13.15	\$0.00	\$58.25
For apprentice rates see "Apprentice- LABORER"						
CAISSON & UNDERPINNING TOP MAN <i>LABORERS - FOUNDATION AND MARINE</i>	06/01/2015	\$35.30	\$7.30	\$13.15	\$0.00	\$55.75
	12/01/2015	\$36.05	\$7.30	\$13.15	\$0.00	\$56.50
	06/01/2016	\$36.80	\$7.30	\$13.15	\$0.00	\$57.25
	12/01/2016	\$37.80	\$7.30	\$13.15	\$0.00	\$58.25
For apprentice rates see "Apprentice- LABORER"						

Classification	Effective Date	Base Wage	Health	Pension	Supplemental Unemployment	Total Rate
CARBIDE CORE DRILL OPERATOR <i>LABORERS - ZONE 1</i>	06/01/2015	\$35.60	\$7.30	\$12.95	\$0.00	\$55.85
	12/01/2015	\$36.35	\$7.30	\$12.95	\$0.00	\$56.60
	06/01/2016	\$37.10	\$7.30	\$12.95	\$0.00	\$57.35
	12/01/2016	\$38.10	\$7.30	\$12.95	\$0.00	\$58.35
For apprentice rates see "Apprentice- LABORER"						
CARPENTER <i>CARPENTERS -ZONE 2 (Eastern Massachusetts)</i>	03/01/2015	\$35.75	\$9.80	\$16.48	\$0.00	\$62.03

Apprentice - CARPENTER - Zone 2 Eastern MA

Effective Date - 03/01/2015

Step	percent	Apprentice Base Wage	Health	Pension	Supplemental Unemployment	Total Rate
1	50	\$17.88	\$9.80	\$1.63	\$0.00	\$29.31
2	60	\$21.45	\$9.80	\$1.63	\$0.00	\$32.88
3	70	\$25.03	\$9.80	\$11.59	\$0.00	\$46.42
4	75	\$26.81	\$9.80	\$11.59	\$0.00	\$48.20
5	80	\$28.60	\$9.80	\$13.22	\$0.00	\$51.62
6	80	\$28.60	\$9.80	\$13.22	\$0.00	\$51.62
7	90	\$32.18	\$9.80	\$14.85	\$0.00	\$56.83
8	90	\$32.18	\$9.80	\$14.85	\$0.00	\$56.83

Notes:

Apprentice to Journeyworker Ratio:1:5

CEMENT MASONRY/PLASTERING <i>BRICKLAYERS LOCAL 3 (BOSTON)</i>	01/01/2015	\$44.90	\$10.90	\$18.71	\$1.30	\$75.81
	07/01/2015	\$45.82	\$10.90	\$18.71	\$1.30	\$76.73
	01/01/2016	\$46.44	\$10.90	\$18.71	\$1.30	\$77.35

Classification

Effective Date Base Wage Health Pension Supplemental Unemployment Total Rate

Apprentice - CEMENT MASONRY/PLASTERING - Eastern Mass (Boston)

Effective Date - 01/01/2015

Step	percent	Apprentice Base Wage	Health	Pension	Supplemental Unemployment	Total Rate
1	50	\$22.45	\$10.90	\$12.21	\$0.00	\$45.56
2	60	\$26.94	\$10.90	\$13.71	\$1.30	\$52.85
3	65	\$29.19	\$10.90	\$14.71	\$1.30	\$56.10
4	70	\$31.43	\$10.90	\$15.71	\$1.30	\$59.34
5	75	\$33.68	\$10.90	\$16.71	\$1.30	\$62.59
6	80	\$35.92	\$10.90	\$17.71	\$1.30	\$65.83
7	90	\$40.41	\$10.90	\$18.71	\$1.30	\$71.32

Effective Date - 07/01/2015

Step	percent	Apprentice Base Wage	Health	Pension	Supplemental Unemployment	Total Rate
1	50	\$22.91	\$10.90	\$12.21	\$0.00	\$46.02
2	60	\$27.49	\$10.90	\$13.71	\$1.30	\$53.40
3	65	\$29.78	\$10.90	\$14.71	\$1.30	\$56.69
4	70	\$32.07	\$10.90	\$15.71	\$1.30	\$59.98
5	75	\$34.37	\$10.90	\$16.71	\$1.30	\$63.28
6	80	\$36.66	\$10.90	\$17.71	\$1.30	\$66.57
7	90	\$41.24	\$10.90	\$18.71	\$1.30	\$72.15

Notes:
Steps 3,4 are 500 hrs. All other steps are 1,000 hrs.

Apprentice to Journeyworker Ratio:1:3

CHAIN SAW OPERATOR	06/01/2015	\$35.60	\$7.30	\$12.95	\$0.00	\$55.85
LABORERS - ZONE 1	12/01/2015	\$36.35	\$7.30	\$12.95	\$0.00	\$56.60
	06/01/2016	\$37.10	\$7.30	\$12.95	\$0.00	\$57.35
	12/01/2016	\$38.10	\$7.30	\$12.95	\$0.00	\$58.35

For apprentice rates see "Apprentice- LABORER"

CLAM SHELLS/SLURRY BUCKETS/HEADING MACHINES	06/01/2015	\$43.83	\$10.00	\$14.55	\$0.00	\$68.38
OPERATING ENGINEERS LOCAL 4	12/01/2015	\$45.08	\$10.00	\$14.55	\$0.00	\$69.63
	06/01/2016	\$45.83	\$10.00	\$14.55	\$0.00	\$70.38
	12/01/2016	\$47.08	\$10.00	\$14.55	\$0.00	\$71.63
	06/01/2017	\$48.08	\$10.00	\$14.55	\$0.00	\$72.63
	12/01/2017	\$49.08	\$10.00	\$14.55	\$0.00	\$73.63

For apprentice rates see "Apprentice- OPERATING ENGINEERS"

COMPRESSOR OPERATOR	06/01/2015	\$29.61	\$10.00	\$14.55	\$0.00	\$54.16
OPERATING ENGINEERS LOCAL 4	12/01/2015	\$30.48	\$10.00	\$14.55	\$0.00	\$55.03
	06/01/2016	\$31.00	\$10.00	\$14.55	\$0.00	\$55.55
	12/01/2016	\$31.87	\$10.00	\$14.55	\$0.00	\$56.42
	06/01/2017	\$32.56	\$10.00	\$14.55	\$0.00	\$57.11
	12/01/2017	\$33.25	\$10.00	\$14.55	\$0.00	\$57.80

For apprentice rates see "Apprentice- OPERATING ENGINEERS"

Classification	Effective Date	Base Wage	Health	Pension	Supplemental Unemployment	Total Rate
DELEADER (BRIDGE) PAINTERS LOCAL 35 - ZONE 2	01/01/2015	\$47.66	\$7.85	\$16.10	\$0.00	\$71.61
	07/01/2015	\$48.56	\$7.85	\$16.10	\$0.00	\$72.51
	01/01/2016	\$49.51	\$7.85	\$16.10	\$0.00	\$73.46
	07/01/2016	\$50.46	\$7.85	\$16.10	\$0.00	\$74.41
	01/01/2017	\$51.41	\$7.85	\$16.10	\$0.00	\$75.36

Apprentice - PAINTER Local 35 - BRIDGES/TANKS

Effective Date - 01/01/2015

Step	percent	Apprentice Base Wage	Health	Pension	Supplemental Unemployment	Total Rate
1	50	\$23.83	\$7.85	\$0.00	\$0.00	\$31.68
2	55	\$26.21	\$7.85	\$3.66	\$0.00	\$37.72
3	60	\$28.60	\$7.85	\$3.99	\$0.00	\$40.44
4	65	\$30.98	\$7.85	\$4.32	\$0.00	\$43.15
5	70	\$33.36	\$7.85	\$14.11	\$0.00	\$55.32
6	75	\$35.75	\$7.85	\$14.44	\$0.00	\$58.04
7	80	\$38.13	\$7.85	\$14.77	\$0.00	\$60.75
8	90	\$42.89	\$7.85	\$15.44	\$0.00	\$66.18

Effective Date - 07/01/2015

Step	percent	Apprentice Base Wage	Health	Pension	Supplemental Unemployment	Total Rate
1	50	\$24.28	\$7.85	\$0.00	\$0.00	\$32.13
2	55	\$26.71	\$7.85	\$3.66	\$0.00	\$38.22
3	60	\$29.14	\$7.85	\$3.99	\$0.00	\$40.98
4	65	\$31.56	\$7.85	\$4.32	\$0.00	\$43.73
5	70	\$33.99	\$7.85	\$14.11	\$0.00	\$55.95
6	75	\$36.42	\$7.85	\$14.44	\$0.00	\$58.71
7	80	\$38.85	\$7.85	\$14.77	\$0.00	\$61.47
8	90	\$43.70	\$7.85	\$15.44	\$0.00	\$66.99

Notes:

Steps are 750 hrs.

Apprentice to Journeyworker Ratio:1:1

DEMO: ADZEMAN LABORERS - ZONE 1	06/01/2015	\$35.50	\$7.30	\$12.95	\$0.00	\$55.75
	12/01/2015	\$36.25	\$7.30	\$12.95	\$0.00	\$56.50
For apprentice rates see "Apprentice- LABORER"						
DEMO: BACKHOE/LOADER/HAMMER OPERATOR LABORERS - ZONE 1	06/01/2015	\$36.50	\$7.30	\$12.95	\$0.00	\$56.75
	12/01/2015	\$37.25	\$7.30	\$12.95	\$0.00	\$57.50
For apprentice rates see "Apprentice- LABORER"						
DEMO: BURNERS LABORERS - ZONE 1	06/01/2015	\$36.25	\$7.30	\$12.95	\$0.00	\$56.50
	12/01/2015	\$37.00	\$7.30	\$12.95	\$0.00	\$57.25
For apprentice rates see "Apprentice- LABORER"						
DEMO: CONCRETE CUTTER/SAWYER LABORERS - ZONE 1	06/01/2015	\$36.50	\$7.30	\$12.95	\$0.00	\$56.75
	12/01/2015	\$37.25	\$7.30	\$12.95	\$0.00	\$57.50
For apprentice rates see "Apprentice- LABORER"						

Classification	Effective Date	Base Wage	Health	Pension	Supplemental Unemployment	Total Rate
DEMO: JACKHAMMER OPERATOR <i>LABORERS - ZONE 1</i>	06/01/2015	\$36.25	\$7.30	\$12.95	\$0.00	\$56.50
	12/01/2015	\$37.00	\$7.30	\$12.95	\$0.00	\$57.25
For apprentice rates see "Apprentice- LABORER"						
DEMO: WRECKING LABORER <i>LABORERS - ZONE 1</i>	06/01/2015	\$35.50	\$7.30	\$12.95	\$0.00	\$55.75
	12/01/2015	\$36.25	\$7.30	\$12.95	\$0.00	\$56.50
For apprentice rates see "Apprentice- LABORER"						
DIRECTIONAL DRILL MACHINE OPERATOR <i>OPERATING ENGINEERS LOCAL 4</i>	06/01/2015	\$42.42	\$10.00	\$14.55	\$0.00	\$66.97
	12/01/2015	\$43.66	\$10.00	\$14.55	\$0.00	\$68.21
	06/01/2016	\$44.41	\$10.00	\$14.55	\$0.00	\$68.96
	12/01/2016	\$45.64	\$10.00	\$14.55	\$0.00	\$70.19
	06/01/2017	\$46.63	\$10.00	\$14.55	\$0.00	\$71.18
	12/01/2017	\$47.62	\$10.00	\$14.55	\$0.00	\$72.17
For apprentice rates see "Apprentice- OPERATING ENGINEERS"						
DIVER <i>PILE DRIVER LOCAL 56 (ZONE 1)</i>	08/01/2014	\$58.24	\$9.80	\$18.17	\$0.00	\$86.21
	08/01/2015	\$60.34	\$9.80	\$18.17	\$0.00	\$88.31
DIVER TENDER <i>PILE DRIVER LOCAL 56 (ZONE 1)</i>	08/01/2014	\$41.60	\$9.80	\$18.17	\$0.00	\$69.57
	08/01/2015	\$43.10	\$9.80	\$18.17	\$0.00	\$71.07
DIVER TENDER (EFFLUENT) <i>PILE DRIVER LOCAL 56 (ZONE 1)</i>	08/01/2014	\$62.40	\$9.80	\$18.17	\$0.00	\$90.37
	08/01/2015	\$64.65	\$9.80	\$18.17	\$0.00	\$92.62
DIVER/SLURRY (EFFLUENT) <i>PILE DRIVER LOCAL 56 (ZONE 1)</i>	08/01/2014	\$87.36	\$9.80	\$18.17	\$0.00	\$115.33
	08/01/2015	\$90.51	\$9.80	\$18.17	\$0.00	\$118.48
DRAWBRIDGE OPERATOR (Construction) <i>ELECTRICIANS LOCAL 103</i>	03/01/2015	\$45.17	\$13.00	\$15.40	\$0.00	\$73.57
	09/01/2015	\$46.13	\$13.00	\$15.43	\$0.00	\$74.56
	03/01/2016	\$47.08	\$13.00	\$15.46	\$0.00	\$75.54
For apprentice rates see "Apprentice- ELECTRICIAN"						
ELECTRICIAN <i>ELECTRICIANS LOCAL 103</i>	03/01/2015	\$45.17	\$13.00	\$15.40	\$0.00	\$73.57
	09/01/2015	\$46.13	\$13.00	\$15.43	\$0.00	\$74.56
	03/01/2016	\$47.08	\$13.00	\$15.46	\$0.00	\$75.54

Apprentice - ELECTRICIAN - Local 103

Effective Date - 03/01/2015

Step	percent	Apprentice Base Wage	Health	Pension	Supplemental Unemployment	Total Rate
1	40	\$18.07	\$13.00	\$0.54	\$0.00	\$31.61
2	40	\$18.07	\$13.00	\$0.54	\$0.00	\$31.61
3	45	\$20.33	\$13.00	\$11.64	\$0.00	\$44.97
4	45	\$20.33	\$13.00	\$11.64	\$0.00	\$44.97
5	50	\$22.59	\$13.00	\$11.98	\$0.00	\$47.57
6	55	\$24.84	\$13.00	\$12.33	\$0.00	\$50.17
7	60	\$27.10	\$13.00	\$12.66	\$0.00	\$52.76
8	65	\$29.36	\$13.00	\$13.01	\$0.00	\$55.37
9	70	\$31.62	\$13.00	\$13.35	\$0.00	\$57.97
10	75	\$33.88	\$13.00	\$13.70	\$0.00	\$60.58

Effective Date - 09/01/2015

Step	percent	Apprentice Base Wage	Health	Pension	Supplemental Unemployment	Total Rate
1	40	\$18.45	\$13.00	\$0.55	\$0.00	\$32.00
2	40	\$18.45	\$13.00	\$0.55	\$0.00	\$32.00
3	45	\$20.76	\$13.00	\$11.65	\$0.00	\$45.41
4	45	\$20.76	\$13.00	\$11.65	\$0.00	\$45.41
5	50	\$23.07	\$13.00	\$11.99	\$0.00	\$48.06
6	55	\$25.37	\$13.00	\$12.34	\$0.00	\$50.71
7	60	\$27.68	\$13.00	\$12.68	\$0.00	\$53.36
8	65	\$29.98	\$13.00	\$13.03	\$0.00	\$56.01
9	70	\$32.29	\$13.00	\$13.37	\$0.00	\$58.66
10	75	\$34.60	\$13.00	\$13.72	\$0.00	\$61.32

Notes :
App Prior 1/1/03; 30/35/40/45/50/55/65/70/75/80

Apprentice to Journeyworker Ratio:2:3***

ELEVATOR CONSTRUCTOR	01/01/2015	\$53.30	\$13.58	\$14.21	\$0.00	\$81.09
ELEVATOR CONSTRUCTORS LOCAL 4	01/01/2016	\$54.53	\$14.43	\$14.96	\$0.00	\$83.92
	01/01/2017	\$55.86	\$15.28	\$15.71	\$0.00	\$86.85

Classification

Effective Date Base Wage Health Pension Supplemental Unemployment Total Rate

Apprentice - ELEVATOR CONSTRUCTOR - Local 4

Effective Date - 01/01/2015

Step	percent	Apprentice Base Wage	Health	Pension	Supplemental Unemployment	Total Rate
1	50	\$26.65	\$13.58	\$0.00	\$0.00	\$40.23
2	55	\$29.32	\$13.58	\$14.21	\$0.00	\$57.11
3	65	\$34.65	\$13.58	\$14.21	\$0.00	\$62.44
4	70	\$37.31	\$13.58	\$14.21	\$0.00	\$65.10
5	80	\$42.64	\$13.58	\$14.21	\$0.00	\$70.43

Effective Date - 01/01/2016

Step	percent	Apprentice Base Wage	Health	Pension	Supplemental Unemployment	Total Rate
1	50	\$27.27	\$14.43	\$0.00	\$0.00	\$41.70
2	55	\$29.99	\$14.43	\$14.96	\$0.00	\$59.38
3	65	\$35.44	\$14.43	\$14.96	\$0.00	\$64.83
4	70	\$38.17	\$14.43	\$14.96	\$0.00	\$67.56
5	80	\$43.62	\$14.43	\$14.96	\$0.00	\$73.01

Notes:

Steps 1-2 are 6 mos.; Steps 3-5 are 1 year

Apprentice to Journeyworker Ratio:1:1

ELEVATOR CONSTRUCTOR HELPER <i>ELEVATOR CONSTRUCTORS LOCAL 4</i>	01/01/2015	\$37.31	\$13.58	\$14.21	\$0.00	\$65.10
	01/01/2016	\$38.17	\$14.43	\$14.96	\$0.00	\$67.56
	01/01/2017	\$39.10	\$15.28	\$15.71	\$0.00	\$70.09

For apprentice rates see "Apprentice - ELEVATOR CONSTRUCTOR"

FENCE & GUARD RAIL ERECTOR <i>LABORERS - ZONE 1</i>	06/01/2015	\$35.60	\$7.30	\$12.95	\$0.00	\$55.85
	12/01/2015	\$36.35	\$7.30	\$12.95	\$0.00	\$56.60
	06/01/2016	\$37.10	\$7.30	\$12.95	\$0.00	\$57.35
	12/01/2016	\$38.10	\$7.30	\$12.95	\$0.00	\$58.35

For apprentice rates see "Apprentice- LABORER"

FIELD ENG.INST.PERSON-BLDG,SITE,HVY/HWY <i>OPERATING ENGINEERS LOCAL 4</i>	05/01/2015	\$40.22	\$10.00	\$14.30	\$0.00	\$64.52
	11/01/2015	\$40.80	\$10.00	\$14.30	\$0.00	\$65.10
	05/01/2016	\$41.69	\$10.00	\$14.30	\$0.00	\$65.99
	11/01/2016	\$42.28	\$10.00	\$14.30	\$0.00	\$66.58
	05/01/2017	\$43.16	\$10.00	\$14.30	\$0.00	\$67.46
	11/01/2017	\$43.89	\$10.00	\$14.30	\$0.00	\$68.19
	05/01/2018	\$44.60	\$10.00	\$14.30	\$0.00	\$68.90

For apprentice rates see "Apprentice- OPERATING ENGINEERS"

FIELD ENG.PARTY CHIEF-BLDG,SITE,HVY/HWY <i>OPERATING ENGINEERS LOCAL 4</i>	05/01/2015	\$41.65	\$10.00	\$14.30	\$0.00	\$65.95
	11/01/2015	\$42.24	\$10.00	\$14.30	\$0.00	\$66.54
	05/01/2016	\$43.13	\$10.00	\$14.30	\$0.00	\$67.43
	11/01/2016	\$43.73	\$10.00	\$14.30	\$0.00	\$68.03
	05/01/2017	\$44.62	\$10.00	\$14.30	\$0.00	\$68.92
	11/01/2017	\$45.35	\$10.00	\$14.30	\$0.00	\$69.65
	05/01/2018	\$46.07	\$10.00	\$14.30	\$0.00	\$70.37

For apprentice rates see "Apprentice- OPERATING ENGINEERS"

Classification	Effective Date	Base Wage	Health	Pension	Supplemental Unemployment	Total Rate
FIELD ENG.ROD PERSON-BLDG,SITE,HVY/HWY <i>OPERATING ENGINEERS LOCAL 4</i>	05/01/2015	\$21.68	\$10.00	\$14.30	\$0.00	\$45.98
	11/01/2015	\$22.02	\$10.00	\$14.30	\$0.00	\$46.32
	05/01/2016	\$22.54	\$10.00	\$14.30	\$0.00	\$46.84
	11/01/2016	\$22.89	\$10.00	\$14.30	\$0.00	\$47.19
	05/01/2017	\$23.42	\$10.00	\$14.30	\$0.00	\$47.72
	11/01/2017	\$23.84	\$10.00	\$14.30	\$0.00	\$48.14
	05/01/2018	\$24.27	\$10.00	\$14.30	\$0.00	\$48.57
For apprentice rates see "Apprentice- OPERATING ENGINEERS"						
FIRE ALARM INSTALLER <i>ELECTRICIANS LOCAL 103</i>	03/01/2015	\$45.17	\$13.00	\$15.40	\$0.00	\$73.57
	09/01/2015	\$46.13	\$13.00	\$15.43	\$0.00	\$74.56
	03/01/2016	\$47.08	\$13.00	\$15.46	\$0.00	\$75.54
For apprentice rates see "Apprentice- ELECTRICIAN"						
FIRE ALARM REPAIR / MAINTENANCE / COMMISSIONING <i>ELECTRICIANS LOCAL 103</i>	03/01/2015	\$33.88	\$13.00	\$13.70	\$0.00	\$60.58
	09/01/2015	\$34.60	\$13.00	\$13.72	\$0.00	\$61.32
	03/01/2016	\$35.31	\$13.00	\$13.74	\$0.00	\$62.05
For apprentice rates see "Apprentice- TELECOMMUNICATIONS TECHNICIAN"						
FIREMAN (ASST. ENGINEER) <i>OPERATING ENGINEERS LOCAL 4</i>	06/01/2015	\$35.64	\$10.00	\$14.55	\$0.00	\$60.19
	12/01/2015	\$36.69	\$10.00	\$14.55	\$0.00	\$61.24
	06/01/2016	\$37.31	\$10.00	\$14.55	\$0.00	\$61.86
	12/01/2016	\$38.35	\$10.00	\$14.55	\$0.00	\$62.90
	06/01/2017	\$39.19	\$10.00	\$14.55	\$0.00	\$63.74
	12/01/2017	\$40.02	\$10.00	\$14.55	\$0.00	\$64.57
For apprentice rates see "Apprentice- OPERATING ENGINEERS"						
FLAGGER & SIGNALER <i>LABORERS - ZONE 1</i>	06/01/2015	\$20.50	\$7.30	\$12.95	\$0.00	\$40.75
	12/01/2015	\$20.50	\$7.30	\$12.95	\$0.00	\$40.75
	06/01/2016	\$20.50	\$7.30	\$12.95	\$0.00	\$40.75
	12/01/2016	\$20.50	\$7.30	\$12.95	\$0.00	\$40.75
For apprentice rates see "Apprentice- LABORER"						
FLOORCOVERER <i>FLOORCOVERERS LOCAL 2168 ZONE 1</i>	09/01/2014	\$40.40	\$9.80	\$17.21	\$0.00	\$67.41

Classification

Effective Date Base Wage Health Pension Supplemental Unemployment Total Rate

Apprentice - FLOORCOVERER - Local 2168 Zone 1

Effective Date - 09/01/2014

Step	percent	Apprentice Base Wage	Health	Pension	Supplemental Unemployment	Total Rate
1	50	\$20.20	\$9.80	\$1.79	\$0.00	\$31.79
2	55	\$22.22	\$9.80	\$1.79	\$0.00	\$33.81
3	60	\$24.24	\$9.80	\$11.84	\$0.00	\$45.88
4	65	\$26.26	\$9.80	\$11.84	\$0.00	\$47.90
5	70	\$28.28	\$9.80	\$13.63	\$0.00	\$51.71
6	75	\$30.30	\$9.80	\$13.63	\$0.00	\$53.73
7	80	\$32.32	\$9.80	\$15.42	\$0.00	\$57.54
8	85	\$34.34	\$9.80	\$15.42	\$0.00	\$59.56

Notes:

Steps are 750 hrs.

Apprentice to Journeyworker Ratio:1:1

FORK LIFT/CHERRY PICKER <i>OPERATING ENGINEERS LOCAL 4</i>	06/01/2015	\$42.83	\$10.00	\$14.55	\$0.00	\$67.38
	12/01/2015	\$44.08	\$10.00	\$14.55	\$0.00	\$68.63
	06/01/2016	\$44.83	\$10.00	\$14.55	\$0.00	\$69.38
	12/01/2016	\$46.08	\$10.00	\$14.55	\$0.00	\$70.63
	06/01/2017	\$47.08	\$10.00	\$14.55	\$0.00	\$71.63
	12/01/2017	\$48.08	\$10.00	\$14.55	\$0.00	\$72.63

For apprentice rates see "Apprentice- OPERATING ENGINEERS"

GENERATOR/LIGHTING PLANT/HEATERS <i>OPERATING ENGINEERS LOCAL 4</i>	06/01/2015	\$29.61	\$10.00	\$14.55	\$0.00	\$54.16
	12/01/2015	\$30.48	\$10.00	\$14.55	\$0.00	\$55.03
	06/01/2016	\$31.00	\$10.00	\$14.55	\$0.00	\$55.55
	12/01/2016	\$31.87	\$10.00	\$14.55	\$0.00	\$56.42
	06/01/2017	\$32.56	\$10.00	\$14.55	\$0.00	\$57.11
	12/01/2017	\$33.25	\$10.00	\$14.55	\$0.00	\$57.80

For apprentice rates see "Apprentice- OPERATING ENGINEERS"

GLAZIER (GLASS PLANK/AIR BARRIER/INTERIOR SYSTEMS) <i>GLAZIERS LOCAL 35 (ZONE 2)</i>	01/01/2015	\$37.16	\$7.85	\$16.10	\$0.00	\$61.11
	07/01/2015	\$38.06	\$7.85	\$16.10	\$0.00	\$62.01
	01/01/2016	\$39.01	\$7.85	\$16.10	\$0.00	\$62.96
	07/01/2016	\$39.96	\$7.85	\$16.10	\$0.00	\$63.91
	01/01/2017	\$40.91	\$7.85	\$16.10	\$0.00	\$64.86

Apprentice - GLAZIER - Local 35 Zone 2

Effective Date - 01/01/2015

Step	percent	Apprentice Base Wage	Health	Pension	Supplemental Unemployment	Total Rate
1	50	\$18.58	\$7.85	\$0.00	\$0.00	\$26.43
2	55	\$20.44	\$7.85	\$3.66	\$0.00	\$31.95
3	60	\$22.30	\$7.85	\$3.99	\$0.00	\$34.14
4	65	\$24.15	\$7.85	\$4.32	\$0.00	\$36.32
5	70	\$26.01	\$7.85	\$14.11	\$0.00	\$47.97
6	75	\$27.87	\$7.85	\$14.44	\$0.00	\$50.16
7	80	\$29.73	\$7.85	\$14.77	\$0.00	\$52.35
8	90	\$33.44	\$7.85	\$15.44	\$0.00	\$56.73

Effective Date - 07/01/2015

Step	percent	Apprentice Base Wage	Health	Pension	Supplemental Unemployment	Total Rate
1	50	\$19.03	\$7.85	\$0.00	\$0.00	\$26.88
2	55	\$20.93	\$7.85	\$3.66	\$0.00	\$32.44
3	60	\$22.84	\$7.85	\$3.99	\$0.00	\$34.68
4	65	\$24.74	\$7.85	\$4.32	\$0.00	\$36.91
5	70	\$26.64	\$7.85	\$14.11	\$0.00	\$48.60
6	75	\$28.55	\$7.85	\$14.44	\$0.00	\$50.84
7	80	\$30.45	\$7.85	\$14.77	\$0.00	\$53.07
8	90	\$34.25	\$7.85	\$15.44	\$0.00	\$57.54

Notes:

Steps are 750 hrs.

Apprentice to Journeyworker Ratio:1:1

HOISTING ENGINEER/CRANES/GRADALLS	06/01/2015	\$42.83	\$10.00	\$14.55	\$0.00	\$67.38
OPERATING ENGINEERS LOCAL 4	12/01/2015	\$44.08	\$10.00	\$14.55	\$0.00	\$68.63
	06/01/2016	\$44.83	\$10.00	\$14.55	\$0.00	\$69.38
	12/01/2016	\$46.08	\$10.00	\$14.55	\$0.00	\$70.63
	06/01/2017	\$47.08	\$10.00	\$14.55	\$0.00	\$71.63
	12/01/2017	\$48.08	\$10.00	\$14.55	\$0.00	\$72.63

Classification

Effective Date Base Wage Health Pension Supplemental Unemployment Total Rate

Apprentice - OPERATING ENGINEERS - Local 4

Effective Date - 06/01/2015

Step	percent	Apprentice Base Wage	Health	Pension	Supplemental Unemployment	Total Rate
1	55	\$23.56	\$10.00	\$0.00	\$0.00	\$33.56
2	60	\$25.70	\$10.00	\$14.55	\$0.00	\$50.25
3	65	\$27.84	\$10.00	\$14.55	\$0.00	\$52.39
4	70	\$29.98	\$10.00	\$14.55	\$0.00	\$54.53
5	75	\$32.12	\$10.00	\$14.55	\$0.00	\$56.67
6	80	\$34.26	\$10.00	\$14.55	\$0.00	\$58.81
7	85	\$36.41	\$10.00	\$14.55	\$0.00	\$60.96
8	90	\$38.55	\$10.00	\$14.55	\$0.00	\$63.10

Effective Date - 12/01/2015

Step	percent	Apprentice Base Wage	Health	Pension	Supplemental Unemployment	Total Rate
1	55	\$24.24	\$10.00	\$0.00	\$0.00	\$34.24
2	60	\$26.45	\$10.00	\$14.55	\$0.00	\$51.00
3	65	\$28.65	\$10.00	\$14.55	\$0.00	\$53.20
4	70	\$30.86	\$10.00	\$14.55	\$0.00	\$55.41
5	75	\$33.06	\$10.00	\$14.55	\$0.00	\$57.61
6	80	\$35.26	\$10.00	\$14.55	\$0.00	\$59.81
7	85	\$37.47	\$10.00	\$14.55	\$0.00	\$62.02
8	90	\$39.67	\$10.00	\$14.55	\$0.00	\$64.22

Notes:

Apprentice to Journeyworker Ratio:1:6

HVAC (DUCTWORK) SHEETMETAL WORKERS LOCAL 17 - A	02/01/2015	\$43.28	\$10.20	\$20.54	\$2.22	\$76.24
	08/01/2015	\$44.28	\$10.20	\$20.54	\$2.22	\$77.24
	02/01/2016	\$45.28	\$10.20	\$20.54	\$2.22	\$78.24
	08/01/2016	\$46.43	\$10.20	\$20.54	\$2.22	\$79.39
	02/01/2017	\$47.53	\$10.20	\$20.54	\$2.22	\$80.49
	08/01/2017	\$48.63	\$10.20	\$20.54	\$2.22	\$81.59
	02/01/2018	\$49.78	\$10.20	\$20.54	\$2.22	\$82.74

For apprentice rates see "Apprentice- SHEET METAL WORKER"

HVAC (ELECTRICAL CONTROLS) ELECTRICIANS LOCAL 103	03/01/2015	\$45.17	\$13.00	\$15.40	\$0.00	\$73.57
	09/01/2015	\$46.13	\$13.00	\$15.43	\$0.00	\$74.56
	03/01/2016	\$47.08	\$13.00	\$15.46	\$0.00	\$75.54

For apprentice rates see "Apprentice- ELECTRICIAN"

Classification	Effective Date	Base Wage	Health	Pension	Supplemental Unemployment	Total Rate
HVAC (TESTING AND BALANCING - AIR) <i>SHEETMETAL WORKERS LOCAL 17 - A</i>	02/01/2015	\$43.28	\$10.20	\$20.54	\$2.22	\$76.24
	08/01/2015	\$44.28	\$10.20	\$20.54	\$2.22	\$77.24
	02/01/2016	\$45.28	\$10.20	\$20.54	\$2.22	\$78.24
	08/01/2016	\$46.43	\$10.20	\$20.54	\$2.22	\$79.39
	02/01/2017	\$47.53	\$10.20	\$20.54	\$2.22	\$80.49
	08/01/2017	\$48.63	\$10.20	\$20.54	\$2.22	\$81.59
	02/01/2018	\$49.78	\$10.20	\$20.54	\$2.22	\$82.74
For apprentice rates see "Apprentice- SHEET METAL WORKER"						
HVAC (TESTING AND BALANCING -WATER) <i>PIPEFITTERS LOCAL 537</i>	03/01/2015	\$48.69	\$9.70	\$16.89	\$0.00	\$75.28
	09/01/2015	\$49.69	\$9.70	\$16.89	\$0.00	\$76.28
	03/01/2016	\$50.69	\$9.70	\$16.89	\$0.00	\$77.28
	09/01/2016	\$51.69	\$9.70	\$16.89	\$0.00	\$78.28
	03/01/2017	\$52.69	\$9.70	\$16.89	\$0.00	\$79.28
For apprentice rates see "Apprentice- PIPEFITTER" or "PLUMBER/PIPEFITTER"						
HVAC MECHANIC <i>PIPEFITTERS LOCAL 537</i>	03/01/2015	\$48.69	\$9.70	\$16.89	\$0.00	\$75.28
	09/01/2015	\$49.69	\$9.70	\$16.89	\$0.00	\$76.28
	03/01/2016	\$50.69	\$9.70	\$16.89	\$0.00	\$77.28
	09/01/2016	\$51.69	\$9.70	\$16.89	\$0.00	\$78.28
	03/01/2017	\$52.69	\$9.70	\$16.89	\$0.00	\$79.28
For apprentice rates see "Apprentice- PIPEFITTER" or "PLUMBER/PIPEFITTER"						
HYDRAULIC DRILLS <i>LABORERS - ZONE 1</i>	06/01/2015	\$36.10	\$7.30	\$12.95	\$0.00	\$56.35
	12/01/2015	\$36.85	\$7.30	\$12.95	\$0.00	\$57.10
	06/01/2016	\$37.60	\$7.30	\$12.95	\$0.00	\$57.85
	12/01/2016	\$38.60	\$7.30	\$12.95	\$0.00	\$58.85
For apprentice rates see "Apprentice- LABORER"						
INSULATOR (PIPES & TANKS) <i>HEAT & FROST INSULATORS LOCAL 6 (BOSTON)</i>	09/01/2014	\$43.31	\$11.25	\$12.60	\$0.00	\$67.16

Apprentice - ASBESTOS INSULATOR (Pipes & Tanks) - Local 6 Boston

Effective Date - 09/01/2014

Step	percent	Apprentice Base Wage	Health	Pension	Supplemental Unemployment	Total Rate
1	50	\$21.66	\$11.25	\$9.35	\$0.00	\$42.26
2	60	\$25.99	\$11.25	\$10.00	\$0.00	\$47.24
3	70	\$30.32	\$11.25	\$10.65	\$0.00	\$52.22
4	80	\$34.65	\$11.25	\$11.30	\$0.00	\$57.20

Notes:

Steps are 1 year

Apprentice to Journeyworker Ratio:1:4

IRONWORKER/WELDER <i>IRONWORKERS LOCAL 7 (BOSTON AREA)</i>	03/16/2015	\$42.11	\$7.70	\$20.25	\$0.00	\$70.06
---	------------	---------	--------	---------	--------	---------

Classification

Effective Date Base Wage Health Pension Supplemental Unemployment Total Rate

Apprentice - IRONWORKER - Local 7 Boston

Effective Date - 03/16/2015

Step	percent	Apprentice Base Wage	Health	Pension	Supplemental Unemployment	Total Rate
1	60	\$25.27	\$7.70	\$20.25	\$0.00	\$53.22
2	70	\$29.48	\$7.70	\$20.25	\$0.00	\$57.43
3	75	\$31.58	\$7.70	\$20.25	\$0.00	\$59.53
4	80	\$33.69	\$7.70	\$20.25	\$0.00	\$61.64
5	85	\$35.79	\$7.70	\$20.25	\$0.00	\$63.74
6	90	\$37.90	\$7.70	\$20.25	\$0.00	\$65.85

Notes:

** Structural 1:6; Ornamental 1:4

Apprentice to Journeyworker Ratio:**

JACKHAMMER & PAVING BREAKER OPERATOR LABORERS - ZONE 1	06/01/2015	\$35.60	\$7.30	\$12.95	\$0.00	\$55.85
	12/01/2015	\$36.35	\$7.30	\$12.95	\$0.00	\$56.60
	06/01/2016	\$37.10	\$7.30	\$12.95	\$0.00	\$57.35
	12/01/2016	\$38.10	\$7.30	\$12.95	\$0.00	\$58.35

For apprentice rates see "Apprentice- LABORER"

LABORER LABORERS - ZONE 1	06/01/2015	\$35.35	\$7.30	\$12.95	\$0.00	\$55.60
	12/01/2015	\$36.10	\$7.30	\$12.95	\$0.00	\$56.35
	06/01/2016	\$36.85	\$7.30	\$12.95	\$0.00	\$57.10
	12/01/2016	\$37.85	\$7.30	\$12.95	\$0.00	\$58.10

Apprentice - LABORER - Zone 1

Effective Date - 06/01/2015

Step	percent	Apprentice Base Wage	Health	Pension	Supplemental Unemployment	Total Rate
1	60	\$21.21	\$7.30	\$12.95	\$0.00	\$41.46
2	70	\$24.75	\$7.30	\$12.95	\$0.00	\$45.00
3	80	\$28.28	\$7.30	\$12.95	\$0.00	\$48.53
4	90	\$31.82	\$7.30	\$12.95	\$0.00	\$52.07

Effective Date - 12/01/2015

Step	percent	Apprentice Base Wage	Health	Pension	Supplemental Unemployment	Total Rate
1	60	\$21.66	\$7.30	\$12.95	\$0.00	\$41.91
2	70	\$25.27	\$7.30	\$12.95	\$0.00	\$45.52
3	80	\$28.88	\$7.30	\$12.95	\$0.00	\$49.13
4	90	\$32.49	\$7.30	\$12.95	\$0.00	\$52.74

Notes:

Apprentice to Journeyworker Ratio:1:5

Classification	Effective Date	Base Wage	Health	Pension	Supplemental Unemployment	Total Rate
LABORER: CARPENTER TENDER <i>LABORERS - ZONE 1</i>	06/01/2015	\$35.35	\$7.30	\$12.95	\$0.00	\$55.60
	12/01/2015	\$36.10	\$7.30	\$12.95	\$0.00	\$56.35
	06/01/2016	\$36.85	\$7.30	\$12.95	\$0.00	\$57.10
	12/01/2016	\$37.85	\$7.30	\$12.95	\$0.00	\$58.10
For apprentice rates see "Apprentice- LABORER"						
LABORER: CEMENT FINISHER TENDER <i>LABORERS - ZONE 1</i>	06/01/2015	\$35.35	\$7.30	\$12.95	\$0.00	\$55.60
	12/01/2015	\$36.10	\$7.30	\$12.95	\$0.00	\$56.35
	06/01/2016	\$36.85	\$7.30	\$12.95	\$0.00	\$57.10
	12/01/2016	\$37.85	\$7.30	\$12.95	\$0.00	\$58.10
For apprentice rates see "Apprentice- LABORER"						
LABORER: HAZARDOUS WASTE/ASBESTOS REMOVER <i>LABORERS - ZONE 1</i>	06/01/2015	\$35.50	\$7.30	\$12.95	\$0.00	\$55.75
	12/01/2015	\$36.25	\$7.30	\$12.95	\$0.00	\$56.50
For apprentice rates see "Apprentice- LABORER"						
LABORER: MASON TENDER <i>LABORERS - ZONE 1</i>	06/01/2015	\$35.60	\$7.30	\$12.95	\$0.00	\$55.85
	12/01/2015	\$36.35	\$7.30	\$12.95	\$0.00	\$56.60
	06/01/2016	\$37.10	\$7.30	\$12.95	\$0.00	\$57.35
	12/01/2016	\$38.10	\$7.30	\$12.95	\$0.00	\$58.35
For apprentice rates see "Apprentice- LABORER"						
LABORER: MULTI-TRADE TENDER <i>LABORERS - ZONE 1</i>	06/01/2015	\$35.35	\$7.30	\$12.95	\$0.00	\$55.60
	12/01/2015	\$36.10	\$7.30	\$12.95	\$0.00	\$56.35
	06/01/2016	\$36.85	\$7.30	\$12.95	\$0.00	\$57.10
	12/01/2016	\$37.85	\$7.30	\$12.95	\$0.00	\$58.10
For apprentice rates see "Apprentice- LABORER"						
LABORER: TREE REMOVER <i>LABORERS - ZONE 1</i>	06/01/2015	\$35.35	\$7.30	\$12.95	\$0.00	\$55.60
	12/01/2015	\$36.10	\$7.30	\$12.95	\$0.00	\$56.35
	06/01/2016	\$36.85	\$7.30	\$12.95	\$0.00	\$57.10
	12/01/2016	\$37.85	\$7.30	\$12.95	\$0.00	\$58.10
This classification applies to all tree work associated with the removal of standing trees, and trimming and removal of branches and limbs when the work is not done for a utility company for the purpose of operation, maintenance or repair of utility company equipment. For apprentice rates see "Apprentice- LABORER"						
LASER BEAM OPERATOR <i>LABORERS - ZONE 1</i>	06/01/2015	\$35.60	\$7.30	\$12.95	\$0.00	\$55.85
	12/01/2015	\$36.35	\$7.30	\$12.95	\$0.00	\$56.60
	06/01/2016	\$37.10	\$7.30	\$12.95	\$0.00	\$57.35
	12/01/2016	\$38.10	\$7.30	\$12.95	\$0.00	\$58.35
For apprentice rates see "Apprentice- LABORER"						
MARBLE & TILE FINISHERS <i>BRICKLAYERS LOCAL 3 - MARBLE & TILE</i>	02/01/2015	\$37.37	\$10.18	\$17.18	\$0.00	\$64.73
	08/01/2015	\$38.08	\$10.18	\$17.25	\$0.00	\$65.51
	02/01/2016	\$38.53	\$10.18	\$17.25	\$0.00	\$65.96
	08/01/2016	\$39.23	\$10.18	\$17.33	\$0.00	\$66.74
	02/01/2017	\$39.69	\$10.18	\$17.33	\$0.00	\$67.20

Classification

Effective Date Base Wage Health Pension Supplemental Unemployment Total Rate

Apprentice - MARBLE & TILE FINISHER - Local 3 Marble & Tile

Effective Date - 02/01/2015

Step	percent	Apprentice Base Wage	Health	Pension	Supplemental Unemployment	Total Rate
1	50	\$18.69	\$10.18	\$17.18	\$0.00	\$46.05
2	60	\$22.42	\$10.18	\$17.18	\$0.00	\$49.78
3	70	\$26.16	\$10.18	\$17.18	\$0.00	\$53.52
4	80	\$29.90	\$10.18	\$17.18	\$0.00	\$57.26
5	90	\$33.63	\$10.18	\$17.18	\$0.00	\$60.99

Effective Date - 08/01/2015

Step	percent	Apprentice Base Wage	Health	Pension	Supplemental Unemployment	Total Rate
1	50	\$19.04	\$10.18	\$17.25	\$0.00	\$46.47
2	60	\$22.85	\$10.18	\$17.25	\$0.00	\$50.28
3	70	\$26.66	\$10.18	\$17.25	\$0.00	\$54.09
4	80	\$30.46	\$10.18	\$17.25	\$0.00	\$57.89
5	90	\$34.27	\$10.18	\$17.25	\$0.00	\$61.70

Notes:

Apprentice to Journeyworker Ratio:1:3

MARBLE MASONS, TILELAYERS & TERRAZZO MECH	02/01/2015	\$49.00	\$10.18	\$18.50	\$0.00	\$77.68
BRICKLAYERS LOCAL 3 - MARBLE & TILE	08/01/2015	\$49.90	\$10.18	\$18.57	\$0.00	\$78.65
	02/01/2016	\$50.47	\$10.18	\$18.57	\$0.00	\$79.22
	08/01/2016	\$51.37	\$10.18	\$18.65	\$0.00	\$80.20
	02/01/2017	\$51.94	\$10.18	\$18.65	\$0.00	\$80.77

Classification

Effective Date Base Wage Health Pension Supplemental Unemployment Total Rate

Apprentice - MARBLE-TILE-TERRAZZO MECHANIC - Local 3 Marble & Tile

Effective Date - 02/01/2015

Step	percent	Apprentice Base Wage	Health	Pension	Supplemental Unemployment	Total Rate
1	50	\$24.50	\$10.18	\$18.50	\$0.00	\$53.18
2	60	\$29.40	\$10.18	\$18.50	\$0.00	\$58.08
3	70	\$34.30	\$10.18	\$18.50	\$0.00	\$62.98
4	80	\$39.20	\$10.18	\$18.50	\$0.00	\$67.88
5	90	\$44.10	\$10.18	\$18.50	\$0.00	\$72.78

Effective Date - 08/01/2015

Step	percent	Apprentice Base Wage	Health	Pension	Supplemental Unemployment	Total Rate
1	50	\$24.95	\$10.18	\$18.57	\$0.00	\$53.70
2	60	\$29.94	\$10.18	\$18.57	\$0.00	\$58.69
3	70	\$34.93	\$10.18	\$18.57	\$0.00	\$63.68
4	80	\$39.92	\$10.18	\$18.57	\$0.00	\$68.67
5	90	\$44.91	\$10.18	\$18.57	\$0.00	\$73.66

Notes:

Apprentice to Journeyworker Ratio:1:5

MECH. SWEEPER OPERATOR (ON CONST. SITES) <i>OPERATING ENGINEERS LOCAL 4</i>	06/01/2015	\$42.42	\$10.00	\$14.55	\$0.00	\$66.97
	12/01/2015	\$43.66	\$10.00	\$14.55	\$0.00	\$68.21
	06/01/2016	\$44.41	\$10.00	\$14.55	\$0.00	\$68.96
	12/01/2016	\$45.64	\$10.00	\$14.55	\$0.00	\$70.19
	06/01/2017	\$46.63	\$10.00	\$14.55	\$0.00	\$71.18
	12/01/2017	\$47.62	\$10.00	\$14.55	\$0.00	\$72.17

For apprentice rates see "Apprentice- OPERATING ENGINEERS"

MECHANICS MAINTENANCE <i>OPERATING ENGINEERS LOCAL 4</i>	06/01/2015	\$42.42	\$10.00	\$14.55	\$0.00	\$66.97
	12/01/2015	\$43.66	\$10.00	\$14.55	\$0.00	\$68.21
	06/01/2016	\$44.41	\$10.00	\$14.55	\$0.00	\$68.96
	12/01/2016	\$45.64	\$10.00	\$14.55	\$0.00	\$70.19
	06/01/2017	\$46.63	\$10.00	\$14.55	\$0.00	\$71.18
	12/01/2017	\$47.62	\$10.00	\$14.55	\$0.00	\$72.17

For apprentice rates see "Apprentice- OPERATING ENGINEERS"

MILLWRIGHT (Zone 1) <i>MILLWRIGHTS LOCAL 1121 - Zone 1</i>	04/01/2015	\$37.64	\$9.80	\$16.21	\$0.00	\$63.65
---	------------	---------	--------	---------	--------	---------

Classification

Effective Date Base Wage Health Pension Supplemental Unemployment Total Rate

Apprentice - MILLWRIGHT - Local 1121 Zone 1

Effective Date - 04/01/2015

Step	percent	Apprentice Base Wage	Health	Pension	Supplemental Unemployment	Total Rate
1	55	\$20.70	\$9.80	\$4.48	\$0.00	\$34.98
2	65	\$24.47	\$9.80	\$13.36	\$0.00	\$47.63
3	75	\$28.23	\$9.80	\$14.18	\$0.00	\$52.21
4	85	\$31.99	\$9.80	\$14.99	\$0.00	\$56.78

Notes:
Steps are 2,000 hours
Apprentice to Journeyworker Ratio:1:5

MORTAR MIXER <i>LABORERS - ZONE 1</i>	06/01/2015	\$35.60	\$7.30	\$12.95	\$0.00	\$55.85
	12/01/2015	\$36.35	\$7.30	\$12.95	\$0.00	\$56.60
	06/01/2016	\$37.10	\$7.30	\$12.95	\$0.00	\$57.35
	12/01/2016	\$38.10	\$7.30	\$12.95	\$0.00	\$58.35

For apprentice rates see "Apprentice- LABORER"

OILER (OTHER THAN TRUCK CRANES,GRADALLS) <i>OPERATING ENGINEERS LOCAL 4</i>	06/01/2015	\$21.97	\$10.00	\$14.55	\$0.00	\$46.52
	12/01/2015	\$22.62	\$10.00	\$14.55	\$0.00	\$47.17
	06/01/2016	\$23.01	\$10.00	\$14.55	\$0.00	\$47.56
	12/01/2016	\$23.66	\$10.00	\$14.55	\$0.00	\$48.21
	06/01/2017	\$24.17	\$10.00	\$14.55	\$0.00	\$48.72
	12/01/2017	\$24.69	\$10.00	\$14.55	\$0.00	\$49.24

For apprentice rates see "Apprentice- OPERATING ENGINEERS"

OILER (TRUCK CRANES, GRADALLS) <i>OPERATING ENGINEERS LOCAL 4</i>	06/01/2015	\$25.68	\$10.00	\$14.55	\$0.00	\$50.23
	12/01/2015	\$26.43	\$10.00	\$14.55	\$0.00	\$50.98
	06/01/2016	\$26.89	\$10.00	\$14.55	\$0.00	\$51.44
	12/01/2016	\$27.64	\$10.00	\$14.55	\$0.00	\$52.19
	06/01/2017	\$28.24	\$10.00	\$14.55	\$0.00	\$52.79
	12/01/2017	\$28.85	\$10.00	\$14.55	\$0.00	\$53.40

For apprentice rates see "Apprentice- OPERATING ENGINEERS"

OTHER POWER DRIVEN EQUIPMENT - CLASS II <i>OPERATING ENGINEERS LOCAL 4</i>	06/01/2015	\$42.42	\$10.00	\$14.55	\$0.00	\$66.97
	12/01/2015	\$43.66	\$10.00	\$14.55	\$0.00	\$68.21
	06/01/2016	\$44.41	\$10.00	\$14.55	\$0.00	\$68.96
	12/01/2016	\$45.64	\$10.00	\$14.55	\$0.00	\$70.19
	06/01/2017	\$46.63	\$10.00	\$14.55	\$0.00	\$71.18
	12/01/2017	\$47.62	\$10.00	\$14.55	\$0.00	\$72.17

For apprentice rates see "Apprentice- OPERATING ENGINEERS"

PAINTER (BRIDGES/TANKS) <i>PAINTERS LOCAL 35 - ZONE 2</i>	01/01/2015	\$47.66	\$7.85	\$16.10	\$0.00	\$71.61
	07/01/2015	\$48.56	\$7.85	\$16.10	\$0.00	\$72.51
	01/01/2016	\$49.51	\$7.85	\$16.10	\$0.00	\$73.46
	07/01/2016	\$50.46	\$7.85	\$16.10	\$0.00	\$74.41
	01/01/2017	\$51.41	\$7.85	\$16.10	\$0.00	\$75.36

Classification

Effective Date Base Wage Health Pension Supplemental Unemployment Total Rate

Apprentice - PAINTER Local 35 - BRIDGES/TANKS

Effective Date - 01/01/2015

Step	percent	Apprentice Base Wage	Health	Pension	Supplemental Unemployment	Total Rate
1	50	\$23.83	\$7.85	\$0.00	\$0.00	\$31.68
2	55	\$26.21	\$7.85	\$3.66	\$0.00	\$37.72
3	60	\$28.60	\$7.85	\$3.99	\$0.00	\$40.44
4	65	\$30.98	\$7.85	\$4.32	\$0.00	\$43.15
5	70	\$33.36	\$7.85	\$14.11	\$0.00	\$55.32
6	75	\$35.75	\$7.85	\$14.44	\$0.00	\$58.04
7	80	\$38.13	\$7.85	\$14.77	\$0.00	\$60.75
8	90	\$42.89	\$7.85	\$15.44	\$0.00	\$66.18

Effective Date - 07/01/2015

Step	percent	Apprentice Base Wage	Health	Pension	Supplemental Unemployment	Total Rate
1	50	\$24.28	\$7.85	\$0.00	\$0.00	\$32.13
2	55	\$26.71	\$7.85	\$3.66	\$0.00	\$38.22
3	60	\$29.14	\$7.85	\$3.99	\$0.00	\$40.98
4	65	\$31.56	\$7.85	\$4.32	\$0.00	\$43.73
5	70	\$33.99	\$7.85	\$14.11	\$0.00	\$55.95
6	75	\$36.42	\$7.85	\$14.44	\$0.00	\$58.71
7	80	\$38.85	\$7.85	\$14.77	\$0.00	\$61.47
8	90	\$43.70	\$7.85	\$15.44	\$0.00	\$66.99

Notes:

Steps are 750 hrs.

Apprentice to Journeyworker Ratio:1:1

PAINTER (SPRAY OR SANDBLAST, NEW) *	01/01/2015	\$38.56	\$7.85	\$16.10	\$0.00	\$62.51
* If 30% or more of surfaces to be painted are new construction, NEW paint rate shall be used. PAINTERS LOCAL 35 - ZONE 2	07/01/2015	\$39.46	\$7.85	\$16.10	\$0.00	\$63.41
	01/01/2016	\$40.41	\$7.85	\$16.10	\$0.00	\$64.36
	07/01/2016	\$41.36	\$7.85	\$16.10	\$0.00	\$65.31
	01/01/2017	\$42.31	\$7.85	\$16.10	\$0.00	\$66.26

Apprentice - PAINTER Local 35 Zone 2 - Spray/Sandblast - New

Effective Date - 01/01/2015

Step	percent	Apprentice Base Wage	Health	Pension	Supplemental Unemployment	Total Rate
1	50	\$19.28	\$7.85	\$0.00	\$0.00	\$27.13
2	55	\$21.21	\$7.85	\$3.66	\$0.00	\$32.72
3	60	\$23.14	\$7.85	\$3.99	\$0.00	\$34.98
4	65	\$25.06	\$7.85	\$4.32	\$0.00	\$37.23
5	70	\$26.99	\$7.85	\$14.11	\$0.00	\$48.95
6	75	\$28.92	\$7.85	\$14.44	\$0.00	\$51.21
7	80	\$30.85	\$7.85	\$14.77	\$0.00	\$53.47
8	90	\$34.70	\$7.85	\$15.44	\$0.00	\$57.99

Effective Date - 07/01/2015

Step	percent	Apprentice Base Wage	Health	Pension	Supplemental Unemployment	Total Rate
1	50	\$19.73	\$7.85	\$0.00	\$0.00	\$27.58
2	55	\$21.70	\$7.85	\$3.66	\$0.00	\$33.21
3	60	\$23.68	\$7.85	\$3.99	\$0.00	\$35.52
4	65	\$25.65	\$7.85	\$4.32	\$0.00	\$37.82
5	70	\$27.62	\$7.85	\$14.11	\$0.00	\$49.58
6	75	\$29.60	\$7.85	\$14.44	\$0.00	\$51.89
7	80	\$31.57	\$7.85	\$14.77	\$0.00	\$54.19
8	90	\$35.51	\$7.85	\$15.44	\$0.00	\$58.80

Notes:

Steps are 750 hrs.

Apprentice to Journeyworker Ratio:1:1

PAINTER (SPRAY OR SANDBLAST, REPAINT)	01/01/2015	\$36.62	\$7.85	\$16.10	\$0.00	\$60.57
PAINTERS LOCAL 35 - ZONE 2	07/01/2015	\$37.52	\$7.85	\$16.10	\$0.00	\$61.47
	01/01/2016	\$38.47	\$7.85	\$16.10	\$0.00	\$62.42
	07/01/2016	\$39.42	\$7.85	\$16.10	\$0.00	\$63.37
	01/01/2017	\$40.37	\$7.85	\$16.10	\$0.00	\$64.32

Classification

Effective Date Base Wage Health Pension Supplemental Unemployment Total Rate

Apprentice - PAINTER Local 35 Zone 2 - Spray/Sandblast - Repaint

Effective Date - 01/01/2015

Step	percent	Apprentice Base Wage	Health	Pension	Supplemental Unemployment	Total Rate
1	50	\$18.31	\$7.85	\$0.00	\$0.00	\$26.16
2	55	\$20.14	\$7.85	\$3.66	\$0.00	\$31.65
3	60	\$21.97	\$7.85	\$3.99	\$0.00	\$33.81
4	65	\$23.80	\$7.85	\$4.32	\$0.00	\$35.97
5	70	\$25.63	\$7.85	\$14.11	\$0.00	\$47.59
6	75	\$27.47	\$7.85	\$14.44	\$0.00	\$49.76
7	80	\$29.30	\$7.85	\$14.77	\$0.00	\$51.92
8	90	\$32.96	\$7.85	\$15.44	\$0.00	\$56.25

Effective Date - 07/01/2015

Step	percent	Apprentice Base Wage	Health	Pension	Supplemental Unemployment	Total Rate
1	50	\$18.76	\$7.85	\$0.00	\$0.00	\$26.61
2	55	\$20.64	\$7.85	\$3.66	\$0.00	\$32.15
3	60	\$22.51	\$7.85	\$3.99	\$0.00	\$34.35
4	65	\$24.39	\$7.85	\$4.32	\$0.00	\$36.56
5	70	\$26.26	\$7.85	\$14.11	\$0.00	\$48.22
6	75	\$28.14	\$7.85	\$14.44	\$0.00	\$50.43
7	80	\$30.02	\$7.85	\$14.77	\$0.00	\$52.64
8	90	\$33.77	\$7.85	\$15.44	\$0.00	\$57.06

Notes:

Steps are 750 hrs.

Apprentice to Journeyworker Ratio:1:1

PAINTER (TRAFFIC MARKINGS)	06/01/2015	\$35.35	\$7.30	\$12.95	\$0.00	\$55.60
LABORERS - ZONE 1	12/01/2015	\$36.10	\$7.30	\$12.95	\$0.00	\$56.35
	06/01/2016	\$36.85	\$7.30	\$12.95	\$0.00	\$57.10
	12/01/2016	\$37.85	\$7.30	\$12.95	\$0.00	\$58.10

For Apprentice rates see "Apprentice- LABORER"

PAINTER / TAPER (BRUSH, NEW) *	01/01/2015	\$37.16	\$7.85	\$16.10	\$0.00	\$61.11
* If 30% or more of surfaces to be painted are new construction, NEW paint rate shall be used. PAINTERS LOCAL 35 - ZONE 2	07/01/2015	\$38.06	\$7.85	\$16.10	\$0.00	\$62.01
	01/01/2016	\$39.01	\$7.85	\$16.10	\$0.00	\$62.96
	07/01/2016	\$39.96	\$7.85	\$16.10	\$0.00	\$63.91
	01/01/2017	\$40.91	\$7.85	\$16.10	\$0.00	\$64.86

Apprentice - PAINTER - Local 35 Zone 2 - BRUSH NEW

Effective Date - 01/01/2015

Step	percent	Apprentice Base Wage	Health	Pension	Supplemental Unemployment	Total Rate
1	50	\$18.58	\$7.85	\$0.00	\$0.00	\$26.43
2	55	\$20.44	\$7.85	\$3.66	\$0.00	\$31.95
3	60	\$22.30	\$7.85	\$3.99	\$0.00	\$34.14
4	65	\$24.15	\$7.85	\$4.32	\$0.00	\$36.32
5	70	\$26.01	\$7.85	\$14.11	\$0.00	\$47.97
6	75	\$27.87	\$7.85	\$14.44	\$0.00	\$50.16
7	80	\$29.73	\$7.85	\$14.77	\$0.00	\$52.35
8	90	\$33.44	\$7.85	\$15.44	\$0.00	\$56.73

Effective Date - 07/01/2015

Step	percent	Apprentice Base Wage	Health	Pension	Supplemental Unemployment	Total Rate
1	50	\$19.03	\$7.85	\$0.00	\$0.00	\$26.88
2	55	\$20.93	\$7.85	\$3.66	\$0.00	\$32.44
3	60	\$22.84	\$7.85	\$3.99	\$0.00	\$34.68
4	65	\$24.74	\$7.85	\$4.32	\$0.00	\$36.91
5	70	\$26.64	\$7.85	\$14.11	\$0.00	\$48.60
6	75	\$28.55	\$7.85	\$14.44	\$0.00	\$50.84
7	80	\$30.45	\$7.85	\$14.77	\$0.00	\$53.07
8	90	\$34.25	\$7.85	\$15.44	\$0.00	\$57.54

Notes:

Steps are 750 hrs.

Apprentice to Journeyworker Ratio:1:1

PAINTER / TAPER (BRUSH, REPAINT)	01/01/2015	\$35.22	\$7.85	\$16.10	\$0.00	\$59.17
PAINTERS LOCAL 35 - ZONE 2	07/01/2015	\$36.12	\$7.85	\$16.10	\$0.00	\$60.07
	01/01/2016	\$37.07	\$7.85	\$16.10	\$0.00	\$61.02
	07/01/2016	\$38.02	\$7.85	\$16.10	\$0.00	\$61.97
	01/01/2017	\$38.97	\$7.85	\$16.10	\$0.00	\$62.92

Classification

Effective Date Base Wage Health Pension Supplemental Unemployment Total Rate

Apprentice - PAINTER Local 35 Zone 2 - BRUSH REPAINT

Effective Date - 01/01/2015

Step	percent	Apprentice Base Wage	Health	Pension	Supplemental Unemployment	Total Rate
1	50	\$17.61	\$7.85	\$0.00	\$0.00	\$25.46
2	55	\$19.37	\$7.85	\$3.66	\$0.00	\$30.88
3	60	\$21.13	\$7.85	\$3.99	\$0.00	\$32.97
4	65	\$22.89	\$7.85	\$4.32	\$0.00	\$35.06
5	70	\$24.65	\$7.85	\$14.11	\$0.00	\$46.61
6	75	\$26.42	\$7.85	\$14.44	\$0.00	\$48.71
7	80	\$28.18	\$7.85	\$14.77	\$0.00	\$50.80
8	90	\$31.70	\$7.85	\$15.44	\$0.00	\$54.99

Effective Date - 07/01/2015

Step	percent	Apprentice Base Wage	Health	Pension	Supplemental Unemployment	Total Rate
1	50	\$18.06	\$7.85	\$0.00	\$0.00	\$25.91
2	55	\$19.87	\$7.85	\$3.66	\$0.00	\$31.38
3	60	\$21.67	\$7.85	\$3.99	\$0.00	\$33.51
4	65	\$23.48	\$7.85	\$4.32	\$0.00	\$35.65
5	70	\$25.28	\$7.85	\$14.11	\$0.00	\$47.24
6	75	\$27.09	\$7.85	\$14.44	\$0.00	\$49.38
7	80	\$28.90	\$7.85	\$14.77	\$0.00	\$51.52
8	90	\$32.51	\$7.85	\$15.44	\$0.00	\$55.80

Notes:

Steps are 750 hrs.

Apprentice to Journeyworker Ratio:1:1

PANEL & PICKUP TRUCKS DRIVER <i>TEAMSTERS JOINT COUNCIL NO. 10 ZONE A</i>	06/01/2015	\$32.58	\$9.91	\$9.33	\$0.00	\$51.82
	08/01/2015	\$32.58	\$10.41	\$9.33	\$0.00	\$52.32
	12/01/2015	\$32.58	\$10.41	\$10.08	\$0.00	\$53.07
	06/01/2016	\$33.08	\$10.41	\$10.08	\$0.00	\$53.57
	08/01/2016	\$33.08	\$10.91	\$10.08	\$0.00	\$54.07
	12/01/2016	\$33.08	\$10.91	\$10.89	\$0.00	\$54.88
PIER AND DOCK CONSTRUCTOR (UNDERPINNING AND DECK) <i>PILE DRIVER LOCAL 56 (ZONE 1)</i>	08/01/2014	\$41.60	\$9.80	\$18.17	\$0.00	\$69.57
	08/01/2015	\$43.10	\$9.80	\$18.17	\$0.00	\$71.07
PILE DRIVER <i>PILE DRIVER LOCAL 56 (ZONE 1)</i>	08/01/2014	\$41.60	\$9.80	\$18.17	\$0.00	\$69.57
	08/01/2015	\$43.10	\$9.80	\$18.17	\$0.00	\$71.07

Apprentice - PILE DRIVER - Local 56 Zone 1

Effective Date - 08/01/2014

Step	percent	Apprentice Base Wage	Health	Pension	Supplemental Unemployment	Total Rate
1	50	\$20.80	\$9.80	\$18.17	\$0.00	\$48.77
2	60	\$24.96	\$9.80	\$18.17	\$0.00	\$52.93
3	70	\$29.12	\$9.80	\$18.17	\$0.00	\$57.09
4	75	\$31.20	\$9.80	\$18.17	\$0.00	\$59.17
5	80	\$33.28	\$9.80	\$18.17	\$0.00	\$61.25
6	80	\$33.28	\$9.80	\$18.17	\$0.00	\$61.25
7	90	\$37.44	\$9.80	\$18.17	\$0.00	\$65.41
8	90	\$37.44	\$9.80	\$18.17	\$0.00	\$65.41

Effective Date - 08/01/2015

Step	percent	Apprentice Base Wage	Health	Pension	Supplemental Unemployment	Total Rate
1	50	\$21.55	\$9.80	\$18.17	\$0.00	\$49.52
2	60	\$25.86	\$9.80	\$18.17	\$0.00	\$53.83
3	70	\$30.17	\$9.80	\$18.17	\$0.00	\$58.14
4	75	\$32.33	\$9.80	\$18.17	\$0.00	\$60.30
5	80	\$34.48	\$9.80	\$18.17	\$0.00	\$62.45
6	80	\$34.48	\$9.80	\$18.17	\$0.00	\$62.45
7	90	\$38.79	\$9.80	\$18.17	\$0.00	\$66.76
8	90	\$38.79	\$9.80	\$18.17	\$0.00	\$66.76

Notes:

Apprentice to Journeyworker Ratio:1:3

PIPEFITTER & STEAMFITTER	03/01/2015	\$48.69	\$9.70	\$16.89	\$0.00	\$75.28
PIPEFITTERS LOCAL 537	09/01/2015	\$49.69	\$9.70	\$16.89	\$0.00	\$76.28
	03/01/2016	\$50.69	\$9.70	\$16.89	\$0.00	\$77.28
	09/01/2016	\$51.69	\$9.70	\$16.89	\$0.00	\$78.28
	03/01/2017	\$52.69	\$9.70	\$16.89	\$0.00	\$79.28

Classification

Effective Date Base Wage Health Pension Supplemental Unemployment Total Rate

Apprentice - PIPEFITTER - Local 537

Effective Date - 03/01/2015

Step	percent	Apprentice Base Wage	Health	Pension	Supplemental Unemployment	Total Rate
1	40	\$19.48	\$9.70	\$7.50	\$0.00	\$36.68
2	45	\$21.91	\$9.70	\$16.89	\$0.00	\$48.50
3	60	\$29.21	\$9.70	\$16.89	\$0.00	\$55.80
4	70	\$34.08	\$9.70	\$16.89	\$0.00	\$60.67
5	80	\$38.95	\$9.70	\$16.89	\$0.00	\$65.54

Effective Date - 09/01/2015

Step	percent	Apprentice Base Wage	Health	Pension	Supplemental Unemployment	Total Rate
1	40	\$19.88	\$9.70	\$7.50	\$0.00	\$37.08
2	45	\$22.36	\$9.70	\$16.89	\$0.00	\$48.95
3	60	\$29.81	\$9.70	\$16.89	\$0.00	\$56.40
4	70	\$34.78	\$9.70	\$16.89	\$0.00	\$61.37
5	80	\$39.75	\$9.70	\$16.89	\$0.00	\$66.34

Notes:
 ** 1:3; 3:15; 1:10 thereafter / Steps are 1 yr.
 Refrig/AC Mechanic **1:1;1:2;2:4;3:6;4:8;5:10;6:12;7:14;8:17;9:20;10:23(Max)

Apprentice to Journeyworker Ratio:**

PIPELAYER	06/01/2015	\$35.60	\$7.30	\$12.95	\$0.00	\$55.85
LABORERS - ZONE 1	12/01/2015	\$36.35	\$7.30	\$12.95	\$0.00	\$56.60
	06/01/2016	\$37.10	\$7.30	\$12.95	\$0.00	\$57.35
	12/01/2016	\$38.10	\$7.30	\$12.95	\$0.00	\$58.35

For apprentice rates see "Apprentice- LABORER"

PLUMBERS & GASFITTERS	03/01/2015	\$50.21	\$10.32	\$14.89	\$0.00	\$75.42
PLUMBERS & GASFITTERS LOCAL 12	09/01/2015	\$51.21	\$10.32	\$14.89	\$0.00	\$76.42
	03/01/2016	\$52.36	\$10.32	\$14.89	\$0.00	\$77.57
	09/01/2016	\$53.41	\$10.32	\$14.89	\$0.00	\$78.62
	03/01/2017	\$54.41	\$10.32	\$14.89	\$0.00	\$79.62

Classification

Effective Date Base Wage Health Pension Supplemental Unemployment Total Rate

Apprentice - PLUMBER/GASFITTER - Local 12

Effective Date - 03/01/2015

Step	percent	Apprentice Base Wage	Health	Pension	Supplemental Unemployment	Total Rate
1	35	\$17.57	\$10.32	\$5.54	\$0.00	\$33.43
2	40	\$20.08	\$10.32	\$6.27	\$0.00	\$36.67
3	55	\$27.62	\$10.32	\$8.42	\$0.00	\$46.36
4	65	\$32.64	\$10.32	\$9.87	\$0.00	\$52.83
5	75	\$37.66	\$10.32	\$11.30	\$0.00	\$59.28

Effective Date - 09/01/2015

Step	percent	Apprentice Base Wage	Health	Pension	Supplemental Unemployment	Total Rate
1	35	\$17.92	\$10.32	\$5.54	\$0.00	\$33.78
2	40	\$20.48	\$10.32	\$6.27	\$0.00	\$37.07
3	55	\$28.17	\$10.32	\$8.42	\$0.00	\$46.91
4	65	\$33.29	\$10.32	\$9.87	\$0.00	\$53.48
5	75	\$38.41	\$10.32	\$11.30	\$0.00	\$60.03

Notes:

** 1:2; 2:6; 3:10; 4:14; 5:19/Steps are 1 yr
Step4 with lic\$56.05 Step5 with lic\$62.48

Apprentice to Journeyworker Ratio:**

PNEUMATIC CONTROLS (TEMP.) <i>PIPEFITTERS LOCAL 537</i>	03/01/2015	\$48.69	\$9.70	\$16.89	\$0.00	\$75.28
	09/01/2015	\$49.69	\$9.70	\$16.89	\$0.00	\$76.28
	03/01/2016	\$50.69	\$9.70	\$16.89	\$0.00	\$77.28
	09/01/2016	\$51.69	\$9.70	\$16.89	\$0.00	\$78.28
	03/01/2017	\$52.69	\$9.70	\$16.89	\$0.00	\$79.28

For apprentice rates see "Apprentice- PIPEFITTER" or "PLUMBER/PIPEFITTER"

PNEUMATIC DRILL/TOOL OPERATOR <i>LABORERS - ZONE 1</i>	06/01/2015	\$35.60	\$7.30	\$12.95	\$0.00	\$55.85
	12/01/2015	\$36.35	\$7.30	\$12.95	\$0.00	\$56.60
	06/01/2016	\$37.10	\$7.30	\$12.95	\$0.00	\$57.35
	12/01/2016	\$38.10	\$7.30	\$12.95	\$0.00	\$58.35

For apprentice rates see "Apprentice- LABORER"

POWDERMAN & BLASTER <i>LABORERS - ZONE 1</i>	06/01/2015	\$36.35	\$7.30	\$12.95	\$0.00	\$56.60
	12/01/2015	\$37.10	\$7.30	\$12.95	\$0.00	\$57.35
	06/01/2016	\$37.85	\$7.30	\$12.95	\$0.00	\$58.10
	12/01/2016	\$38.85	\$7.30	\$12.95	\$0.00	\$59.10

For apprentice rates see "Apprentice- LABORER"

POWER SHOVEL/DERRICK/TRENCHING MACHINE <i>OPERATING ENGINEERS LOCAL 4</i>	06/01/2015	\$42.83	\$10.00	\$14.55	\$0.00	\$67.38
	12/01/2015	\$44.08	\$10.00	\$14.55	\$0.00	\$68.63
	06/01/2016	\$44.83	\$10.00	\$14.55	\$0.00	\$69.38
	12/01/2016	\$46.08	\$10.00	\$14.55	\$0.00	\$70.63
	06/01/2017	\$47.08	\$10.00	\$14.55	\$0.00	\$71.63
	12/01/2017	\$48.08	\$10.00	\$14.55	\$0.00	\$72.63

For apprentice rates see "Apprentice- OPERATING ENGINEERS"

Classification	Effective Date	Base Wage	Health	Pension	Supplemental Unemployment	Total Rate
PUMP OPERATOR (CONCRETE) <i>OPERATING ENGINEERS LOCAL 4</i>	06/01/2015	\$42.83	\$10.00	\$14.55	\$0.00	\$67.38
	12/01/2015	\$44.08	\$10.00	\$14.55	\$0.00	\$68.63
	06/01/2016	\$44.83	\$10.00	\$14.55	\$0.00	\$69.38
	12/01/2016	\$46.08	\$10.00	\$14.55	\$0.00	\$70.63
	06/01/2017	\$47.08	\$10.00	\$14.55	\$0.00	\$71.63
	12/01/2017	\$48.08	\$10.00	\$14.55	\$0.00	\$72.63
For apprentice rates see "Apprentice- OPERATING ENGINEERS"						
PUMP OPERATOR (DEWATERING, OTHER) <i>OPERATING ENGINEERS LOCAL 4</i>	06/01/2015	\$29.61	\$10.00	\$14.55	\$0.00	\$54.16
	12/01/2015	\$30.48	\$10.00	\$14.55	\$0.00	\$55.03
	06/01/2016	\$31.00	\$10.00	\$14.55	\$0.00	\$55.55
	12/01/2016	\$31.87	\$10.00	\$14.55	\$0.00	\$56.42
	06/01/2017	\$32.56	\$10.00	\$14.55	\$0.00	\$57.11
	12/01/2017	\$33.25	\$10.00	\$14.55	\$0.00	\$57.80
For apprentice rates see "Apprentice- OPERATING ENGINEERS"						
READY MIX CONCRETE DRIVERS after 4/30/10 (Drivers Hired After 4/30/2010) <i>TEAMSTERS LOCAL 25c</i>	05/01/2015	\$27.88	\$7.73	\$8.92	\$0.00	\$44.53
	07/01/2015	\$27.88	\$7.98	\$8.92	\$0.00	\$44.78
	05/01/2016	\$28.03	\$7.98	\$9.31	\$0.00	\$45.32
	07/01/2016	\$28.03	\$8.23	\$9.31	\$0.00	\$45.57
	05/01/2017	\$28.18	\$8.23	\$9.72	\$0.00	\$46.13
	07/01/2017	\$28.18	\$8.48	\$9.72	\$0.00	\$46.38
READY-MIX CONCRETE DRIVER <i>TEAMSTERS LOCAL 25c</i>	05/01/2015	\$29.18	\$7.73	\$8.92	\$0.00	\$45.83
	07/01/2015	\$29.18	\$7.98	\$8.92	\$0.00	\$46.08
	05/01/2016	\$29.33	\$7.98	\$9.31	\$0.00	\$46.62
	07/01/2016	\$29.33	\$8.23	\$9.31	\$0.00	\$46.87
	05/01/2017	\$29.48	\$8.23	\$9.72	\$0.00	\$47.43
	07/01/2017	\$29.48	\$8.48	\$9.72	\$0.00	\$47.68
RECLAIMERS <i>OPERATING ENGINEERS LOCAL 4</i>	06/01/2015	\$42.42	\$10.00	\$14.55	\$0.00	\$66.97
	12/01/2015	\$43.66	\$10.00	\$14.55	\$0.00	\$68.21
	06/01/2016	\$44.41	\$10.00	\$14.55	\$0.00	\$68.96
	12/01/2016	\$45.64	\$10.00	\$14.55	\$0.00	\$70.19
	06/01/2017	\$46.63	\$10.00	\$14.55	\$0.00	\$71.18
	12/01/2017	\$47.62	\$10.00	\$14.55	\$0.00	\$72.17
For apprentice rates see "Apprentice- OPERATING ENGINEERS"						
RESIDENTIAL WOOD FRAME (All Other Work) <i>CARPENTERS -ZONE 2 (Residential Wood)</i>	04/01/2011	\$24.24	\$8.67	\$15.51	\$0.00	\$48.42
RESIDENTIAL WOOD FRAME CARPENTER ** ** The Residential Wood Frame Carpenter classification applies only to the construction of new, wood frame residences that do not exceed four stories including the basement. <i>CARPENTERS -ZONE 2 (Residential Wood)</i> As of 9/1/09 Carpentry work on wood-frame residential WEATHERIZATION projects shall be paid the RESIDENTIAL WOOD FRAME CARPENTER rate.	05/01/2011	\$24.24	\$6.34	\$6.23	\$0.00	\$36.81

Classification

Effective Date Base Wage Health Pension Supplemental Unemployment Total Rate

Apprentice - CARPENTER (Residential Wood Frame) - Zone 2

Effective Date - 05/01/2011

Step	percent	Apprentice Base Wage	Health	Pension	Supplemental Unemployment	Total Rate
1	60	\$14.54	\$6.34	\$0.00	\$0.00	\$20.88
2	60	\$14.54	\$6.34	\$6.23	\$0.00	\$27.11
3	65	\$15.76	\$6.34	\$6.23	\$0.00	\$28.33
4	70	\$16.97	\$6.34	\$6.23	\$0.00	\$29.54
5	75	\$18.18	\$6.34	\$6.23	\$0.00	\$30.75
6	80	\$19.39	\$6.34	\$6.23	\$0.00	\$31.96
7	85	\$20.60	\$6.34	\$6.23	\$0.00	\$33.17
8	90	\$21.82	\$6.34	\$6.23	\$0.00	\$34.39

Notes:

Apprentice to Journeyworker Ratio:1:5

RIDE-ON MOTORIZED BUGGY OPERATOR <i>LABORERS - ZONE 1</i>	06/01/2015	\$35.60	\$7.30	\$12.95	\$0.00	\$55.85
	12/01/2015	\$36.35	\$7.30	\$12.95	\$0.00	\$56.60
	06/01/2016	\$37.10	\$7.30	\$12.95	\$0.00	\$57.35
	12/01/2016	\$38.10	\$7.30	\$12.95	\$0.00	\$58.35

For apprentice rates see "Apprentice- LABORER"

ROLLER/SPREADER/MULCHING MACHINE <i>OPERATING ENGINEERS LOCAL 4</i>	06/01/2015	\$42.42	\$10.00	\$14.55	\$0.00	\$66.97
	12/01/2015	\$43.66	\$10.00	\$14.55	\$0.00	\$68.21
	06/01/2016	\$44.41	\$10.00	\$14.55	\$0.00	\$68.96
	12/01/2016	\$45.64	\$10.00	\$14.55	\$0.00	\$70.19
	06/01/2017	\$46.63	\$10.00	\$14.55	\$0.00	\$71.18
	12/01/2017	\$47.62	\$10.00	\$14.55	\$0.00	\$72.17

For apprentice rates see "Apprentice- OPERATING ENGINEERS"

ROOFER (Inc.Roofer Waterproofng &Roofer Damproofg) <i>ROOFERS LOCAL 33</i>	02/01/2015	\$40.11	\$10.50	\$11.60	\$0.00	\$62.21
	08/01/2015	\$41.01	\$10.50	\$11.60	\$0.00	\$63.11
	02/01/2016	\$41.91	\$10.50	\$11.60	\$0.00	\$64.01

Classification

Effective Date Base Wage Health Pension Supplemental Unemployment Total Rate

Apprentice - ROOFER - Local 33

Effective Date - 02/01/2015

Step	percent	Apprentice Base Wage	Health	Pension	Supplemental Unemployment	Total Rate
1	50	\$20.06	\$10.50	\$3.38	\$0.00	\$33.94
2	60	\$24.07	\$10.50	\$11.60	\$0.00	\$46.17
3	65	\$26.07	\$10.50	\$11.60	\$0.00	\$48.17
4	75	\$30.08	\$10.50	\$11.60	\$0.00	\$52.18
5	85	\$34.09	\$10.50	\$11.60	\$0.00	\$56.19

Effective Date - 08/01/2015

Step	percent	Apprentice Base Wage	Health	Pension	Supplemental Unemployment	Total Rate
1	50	\$20.51	\$10.50	\$3.38	\$0.00	\$34.39
2	60	\$24.61	\$10.50	\$11.60	\$0.00	\$46.71
3	65	\$26.66	\$10.50	\$11.60	\$0.00	\$48.76
4	75	\$30.76	\$10.50	\$11.60	\$0.00	\$52.86
5	85	\$34.86	\$10.50	\$11.60	\$0.00	\$56.96

Notes: ** 1:5, 2:6-10, the 1:10; Reroofing: 1:4, then 1:1
Step 1 is 2000 hrs.; Steps 2-5 are 1000 hrs.

Apprentice to Journeyworker Ratio:**

ROOFER SLATE / TILE / PRECAST CONCRETE ROOFERS LOCAL 33	02/01/2015	\$40.36	\$10.50	\$11.60	\$0.00	\$62.46
	08/01/2015	\$41.26	\$10.50	\$11.60	\$0.00	\$63.36
	02/01/2016	\$42.16	\$10.50	\$11.60	\$0.00	\$64.26

For apprentice rates see "Apprentice- ROOFER"

SHEETMETAL WORKER SHEETMETAL WORKERS LOCAL 17 - A	02/01/2015	\$43.28	\$10.20	\$20.54	\$2.22	\$76.24
	08/01/2015	\$44.28	\$10.20	\$20.54	\$2.22	\$77.24
	02/01/2016	\$45.28	\$10.20	\$20.54	\$2.22	\$78.24
	08/01/2016	\$46.43	\$10.20	\$20.54	\$2.22	\$79.39
	02/01/2017	\$47.53	\$10.20	\$20.54	\$2.22	\$80.49
	08/01/2017	\$48.63	\$10.20	\$20.54	\$2.22	\$81.59
	02/01/2018	\$49.78	\$10.20	\$20.54	\$2.22	\$82.74

Classification

Effective Date Base Wage Health Pension Supplemental Unemployment Total Rate

Apprentice - SHEET METAL WORKER - Local 17-A

Effective Date - 02/01/2015

Step	percent	Apprentice Base Wage	Health	Pension	Supplemental Unemployment	Total Rate
1	40	\$17.31	\$10.20	\$4.58	\$0.00	\$32.09
2	40	\$17.31	\$10.20	\$4.58	\$0.00	\$32.09
3	45	\$19.48	\$10.20	\$9.09	\$1.16	\$39.93
4	45	\$19.48	\$10.20	\$9.09	\$1.16	\$39.93
5	50	\$21.64	\$10.20	\$9.91	\$1.25	\$43.00
6	50	\$21.64	\$10.20	\$10.16	\$1.26	\$43.26
7	60	\$25.97	\$10.20	\$11.55	\$1.43	\$49.15
8	65	\$28.13	\$10.20	\$12.38	\$1.52	\$52.23
9	75	\$32.46	\$10.20	\$14.02	\$1.70	\$58.38
10	85	\$36.79	\$10.20	\$15.16	\$1.86	\$64.01

Effective Date - 08/01/2015

Step	percent	Apprentice Base Wage	Health	Pension	Supplemental Unemployment	Total Rate
1	40	\$17.71	\$10.20	\$4.58	\$0.00	\$32.49
2	40	\$17.71	\$10.20	\$4.58	\$0.00	\$32.49
3	45	\$19.93	\$10.20	\$9.09	\$1.18	\$40.40
4	45	\$19.93	\$10.20	\$9.09	\$1.18	\$40.40
5	50	\$22.14	\$10.20	\$9.91	\$1.27	\$43.52
6	50	\$22.14	\$10.20	\$10.16	\$1.28	\$43.78
7	60	\$26.57	\$10.20	\$11.55	\$1.45	\$49.77
8	65	\$28.78	\$10.20	\$12.38	\$1.54	\$52.90
9	75	\$33.21	\$10.20	\$14.02	\$1.72	\$59.15
10	85	\$37.64	\$10.20	\$15.16	\$1.89	\$64.89

Notes:
Steps are 6 mos.

Apprentice to Journeyworker Ratio:1:4

SIGN ERECTOR PAINTERS LOCAL 35 - ZONE 2	06/01/2013	\$25.81	\$7.07	\$7.05	\$0.00	\$39.93
--	------------	---------	--------	--------	--------	---------

Classification

Effective Date Base Wage Health Pension Supplemental Unemployment Total Rate

Apprentice - SIGN ERECTOR - Local 35 Zone 2

Effective Date - 06/01/2013

Step	percent	Apprentice Base Wage	Health	Pension	Supplemental Unemployment	Total Rate
1	50	\$12.91	\$7.07	\$0.00	\$0.00	\$19.98
2	55	\$14.20	\$7.07	\$2.45	\$0.00	\$23.72
3	60	\$15.49	\$7.07	\$2.45	\$0.00	\$25.01
4	65	\$16.78	\$7.07	\$2.45	\$0.00	\$26.30
5	70	\$18.07	\$7.07	\$7.05	\$0.00	\$32.19
6	75	\$19.36	\$7.07	\$7.05	\$0.00	\$33.48
7	80	\$20.65	\$7.07	\$7.05	\$0.00	\$34.77
8	85	\$21.94	\$7.07	\$7.05	\$0.00	\$36.06
9	90	\$23.23	\$7.07	\$7.05	\$0.00	\$37.35

Notes:

Steps are 4 mos.

Apprentice to Journeyworker Ratio:1:1

SPECIALIZED EARTH MOVING EQUIP < 35 TONS <i>TEAMSTERS JOINT COUNCIL NO. 10 ZONE A</i>	06/01/2015	\$33.04	\$9.91	\$9.33	\$0.00	\$52.28
	08/01/2015	\$33.04	\$10.41	\$9.33	\$0.00	\$52.78
	12/01/2015	\$33.04	\$10.41	\$10.08	\$0.00	\$53.53
	06/01/2016	\$33.54	\$10.41	\$10.08	\$0.00	\$54.03
	08/01/2016	\$33.54	\$10.91	\$10.08	\$0.00	\$54.53
	12/01/2016	\$33.54	\$10.91	\$10.89	\$0.00	\$55.34
SPECIALIZED EARTH MOVING EQUIP > 35 TONS <i>TEAMSTERS JOINT COUNCIL NO. 10 ZONE A</i>	06/01/2015	\$33.33	\$9.91	\$9.33	\$0.00	\$52.57
	08/01/2015	\$33.33	\$10.41	\$9.33	\$0.00	\$53.07
	12/01/2015	\$33.33	\$10.41	\$10.08	\$0.00	\$53.82
	06/01/2016	\$33.83	\$10.41	\$10.08	\$0.00	\$54.32
	08/01/2016	\$33.83	\$10.91	\$10.08	\$0.00	\$54.82
	12/01/2016	\$33.83	\$10.91	\$10.89	\$0.00	\$55.63
SPRINKLER FITTER <i>SPRINKLER FITTERS LOCAL 550 - (Section A) Zone 1</i>	03/01/2015	\$54.43	\$8.42	\$14.90	\$0.00	\$77.75
	10/01/2015	\$55.58	\$8.42	\$14.90	\$0.00	\$78.90
	01/01/2016	\$55.58	\$8.67	\$15.05	\$0.00	\$79.30
	03/01/2016	\$56.58	\$8.67	\$15.05	\$0.00	\$80.30
	10/01/2016	\$57.73	\$8.67	\$15.05	\$0.00	\$81.45
	03/01/2017	\$58.73	\$8.67	\$15.05	\$0.00	\$82.45

Classification

Effective Date Base Wage Health Pension Supplemental Unemployment Total Rate

Apprentice - SPRINKLER FITTER - Local 550 (Section A) Zone 1

Effective Date - 03/01/2015

Step	percent	Apprentice Base Wage	Health	Pension	Supplemental Unemployment	Total Rate
1	35	\$19.05	\$8.42	\$8.40	\$0.00	\$35.87
2	40	\$21.77	\$8.42	\$8.40	\$0.00	\$38.59
3	45	\$24.49	\$8.42	\$8.40	\$0.00	\$41.31
4	50	\$27.22	\$8.42	\$8.40	\$0.00	\$44.04
5	55	\$29.94	\$8.42	\$8.40	\$0.00	\$46.76
6	60	\$32.66	\$8.42	\$8.40	\$0.00	\$49.48
7	65	\$35.38	\$8.42	\$8.40	\$0.00	\$52.20
8	70	\$38.10	\$8.42	\$8.40	\$0.00	\$54.92
9	75	\$40.82	\$8.42	\$8.40	\$0.00	\$57.64
10	80	\$43.54	\$8.42	\$8.40	\$0.00	\$60.36

Effective Date - 10/01/2015

Step	percent	Apprentice Base Wage	Health	Pension	Supplemental Unemployment	Total Rate
1	35	\$19.45	\$8.42	\$8.40	\$0.00	\$36.27
2	40	\$22.23	\$8.42	\$8.40	\$0.00	\$39.05
3	45	\$25.01	\$8.42	\$8.40	\$0.00	\$41.83
4	50	\$27.79	\$8.42	\$8.40	\$0.00	\$44.61
5	55	\$30.57	\$8.42	\$8.40	\$0.00	\$47.39
6	60	\$33.35	\$8.42	\$8.40	\$0.00	\$50.17
7	65	\$36.13	\$8.42	\$8.40	\$0.00	\$52.95
8	70	\$38.91	\$8.42	\$8.40	\$0.00	\$55.73
9	75	\$41.69	\$8.42	\$8.40	\$0.00	\$58.51
10	80	\$44.46	\$8.42	\$8.40	\$0.00	\$61.28

Notes: Apprentice entered prior 9/30/10:
40/45/50/55/60/65/70/75/80/85
Steps are 850 hours

Apprentice to Journeyworker Ratio:1:3

STEAM BOILER OPERATOR <i>OPERATING ENGINEERS LOCAL 4</i>	06/01/2015	\$42.42	\$10.00	\$14.55	\$0.00	\$66.97
	12/01/2015	\$43.66	\$10.00	\$14.55	\$0.00	\$68.21
	06/01/2016	\$44.41	\$10.00	\$14.55	\$0.00	\$68.96
	12/01/2016	\$45.64	\$10.00	\$14.55	\$0.00	\$70.19
	06/01/2017	\$46.63	\$10.00	\$14.55	\$0.00	\$71.18
	12/01/2017	\$47.62	\$10.00	\$14.55	\$0.00	\$72.17

For apprentice rates see "Apprentice- OPERATING ENGINEERS"

TAMPERS, SELF-PROPELLED OR TRACTOR DRAWN <i>OPERATING ENGINEERS LOCAL 4</i>	06/01/2015	\$42.42	\$10.00	\$14.55	\$0.00	\$66.97
	12/01/2015	\$43.66	\$10.00	\$14.55	\$0.00	\$68.21
	06/01/2016	\$44.41	\$10.00	\$14.55	\$0.00	\$68.96
	12/01/2016	\$45.64	\$10.00	\$14.55	\$0.00	\$70.19
	06/01/2017	\$46.63	\$10.00	\$14.55	\$0.00	\$71.18
	12/01/2017	\$47.62	\$10.00	\$14.55	\$0.00	\$72.17

For apprentice rates see "Apprentice- OPERATING ENGINEERS"

Classification	Effective Date	Base Wage	Health	Pension	Supplemental Unemployment	Total Rate
TELECOMMUNICATION TECHNICIAN <i>ELECTRICIANS LOCAL 103</i>	03/01/2015	\$33.88	\$13.00	\$13.70	\$0.00	\$60.58
	09/01/2015	\$34.60	\$13.00	\$13.72	\$0.00	\$61.32
	03/01/2016	\$35.31	\$13.00	\$13.74	\$0.00	\$62.05

Apprentice - TELECOMMUNICATION TECHNICIAN - Local 103

Effective Date - 03/01/2015

Step	percent	Apprentice Base Wage	Health	Pension	Supplemental Unemployment	Total Rate
1	40	\$13.55	\$13.00	\$0.41	\$0.00	\$26.96
2	40	\$13.55	\$13.00	\$0.41	\$0.00	\$26.96
3	45	\$15.25	\$13.00	\$10.87	\$0.00	\$39.12
4	45	\$15.25	\$13.00	\$10.87	\$0.00	\$39.12
5	50	\$16.94	\$13.00	\$11.11	\$0.00	\$41.05
6	55	\$18.63	\$13.00	\$11.38	\$0.00	\$43.01
7	60	\$20.33	\$13.00	\$11.64	\$0.00	\$44.97
8	65	\$22.02	\$13.00	\$11.89	\$0.00	\$46.91
9	70	\$23.72	\$13.00	\$12.15	\$0.00	\$48.87
10	75	\$25.41	\$13.00	\$12.41	\$0.00	\$50.82

Effective Date - 09/01/2015

Step	percent	Apprentice Base Wage	Health	Pension	Supplemental Unemployment	Total Rate
1	40	\$13.84	\$13.00	\$0.42	\$0.00	\$27.26
2	40	\$13.84	\$13.00	\$0.42	\$0.00	\$27.26
3	45	\$15.57	\$13.00	\$10.88	\$0.00	\$39.45
4	45	\$15.57	\$13.00	\$10.88	\$0.00	\$39.45
5	50	\$17.30	\$13.00	\$11.14	\$0.00	\$41.44
6	55	\$19.03	\$13.00	\$11.39	\$0.00	\$43.42
7	60	\$20.76	\$13.00	\$11.65	\$0.00	\$45.41
8	65	\$22.49	\$13.00	\$11.90	\$0.00	\$47.39
9	70	\$24.22	\$13.00	\$12.17	\$0.00	\$49.39
10	75	\$25.95	\$13.00	\$12.43	\$0.00	\$51.38

Notes:

Apprentice to Journeyworker Ratio:1:1

TERRAZZO FINISHERS <i>BRICKLAYERS LOCAL 3 - MARBLE & TILE</i>	02/01/2015	\$47.90	\$10.18	\$18.50	\$0.00	\$76.58
	08/01/2015	\$48.80	\$10.18	\$18.57	\$0.00	\$77.55
	02/01/2016	\$49.37	\$10.18	\$18.57	\$0.00	\$78.12
	08/01/2016	\$50.27	\$10.18	\$18.65	\$0.00	\$79.10
	02/01/2017	\$50.84	\$10.18	\$18.65	\$0.00	\$79.67

Classification

Effective Date Base Wage Health Pension Supplemental Unemployment Total Rate

Apprentice - TERRAZZO FINISHER - Local 3 Marble & Tile

Effective Date - 02/01/2015

Step	percent	Apprentice Base Wage	Health	Pension	Supplemental Unemployment	Total Rate
1	50	\$23.95	\$10.18	\$18.50	\$0.00	\$52.63
2	60	\$28.74	\$10.18	\$18.50	\$0.00	\$57.42
3	70	\$33.53	\$10.18	\$18.50	\$0.00	\$62.21
4	80	\$38.32	\$10.18	\$18.50	\$0.00	\$67.00
5	90	\$43.11	\$10.18	\$18.50	\$0.00	\$71.79

Effective Date - 08/01/2015

Step	percent	Apprentice Base Wage	Health	Pension	Supplemental Unemployment	Total Rate
1	50	\$24.40	\$10.18	\$18.57	\$0.00	\$53.15
2	60	\$29.28	\$10.18	\$18.57	\$0.00	\$58.03
3	70	\$34.16	\$10.18	\$18.57	\$0.00	\$62.91
4	80	\$39.04	\$10.18	\$18.57	\$0.00	\$67.79
5	90	\$43.92	\$10.18	\$18.57	\$0.00	\$72.67

Notes:

Apprentice to Journeyworker Ratio:1:3

TEST BORING DRILLER <i>LABORERS - FOUNDATION AND MARINE</i>	06/01/2015	\$36.70	\$7.30	\$13.15	\$0.00	\$57.15
	12/01/2015	\$37.45	\$7.30	\$13.15	\$0.00	\$57.90
	06/01/2016	\$38.20	\$7.30	\$13.15	\$0.00	\$58.65
	12/01/2016	\$39.20	\$7.30	\$13.15	\$0.00	\$59.65

For apprentice rates see "Apprentice- LABORER"

TEST BORING DRILLER HELPER <i>LABORERS - FOUNDATION AND MARINE</i>	06/01/2015	\$35.42	\$7.30	\$13.15	\$0.00	\$55.87
	12/01/2015	\$36.17	\$7.30	\$13.15	\$0.00	\$56.62
	06/01/2016	\$36.92	\$7.30	\$13.15	\$0.00	\$57.37
	12/01/2016	\$37.92	\$7.30	\$13.15	\$0.00	\$58.37

For apprentice rates see "Apprentice- LABORER"

TEST BORING LABORER <i>LABORERS - FOUNDATION AND MARINE</i>	06/01/2015	\$35.30	\$7.30	\$13.15	\$0.00	\$55.75
	12/01/2015	\$36.05	\$7.30	\$13.15	\$0.00	\$56.50
	06/01/2016	\$36.80	\$7.30	\$13.15	\$0.00	\$57.25
	12/01/2016	\$37.80	\$7.30	\$13.15	\$0.00	\$58.25

For apprentice rates see "Apprentice- LABORER"

TRACTORS/PORTABLE STEAM GENERATORS <i>OPERATING ENGINEERS LOCAL 4</i>	06/01/2015	\$42.42	\$10.00	\$14.55	\$0.00	\$66.97
	12/01/2015	\$43.66	\$10.00	\$14.55	\$0.00	\$68.21
	06/01/2016	\$44.41	\$10.00	\$14.55	\$0.00	\$68.96
	12/01/2016	\$45.64	\$10.00	\$14.55	\$0.00	\$70.19
	06/01/2017	\$46.63	\$10.00	\$14.55	\$0.00	\$71.18
	12/01/2017	\$47.62	\$10.00	\$14.55	\$0.00	\$72.17

For apprentice rates see "Apprentice- OPERATING ENGINEERS"

Classification	Effective Date	Base Wage	Health	Pension	Supplemental Unemployment	Total Rate
TRAILERS FOR EARTH MOVING EQUIPMENT <i>TEAMSTERS JOINT COUNCIL NO. 10 ZONE A</i>	06/01/2015	\$33.62	\$9.91	\$9.33	\$0.00	\$52.86
	08/01/2015	\$33.62	\$10.41	\$9.33	\$0.00	\$53.36
	12/01/2015	\$33.62	\$10.41	\$10.08	\$0.00	\$54.11
	06/01/2016	\$34.12	\$10.41	\$10.08	\$0.00	\$54.61
	08/01/2016	\$34.12	\$10.91	\$10.08	\$0.00	\$55.11
	12/01/2016	\$34.12	\$10.91	\$10.89	\$0.00	\$55.92
TUNNEL WORK - COMPRESSED AIR <i>LABORERS (COMPRESSED AIR)</i>	06/01/2015	\$47.58	\$7.30	\$13.55	\$0.00	\$68.43
	12/01/2015	\$48.33	\$7.30	\$13.55	\$0.00	\$69.18
	06/01/2016	\$49.08	\$7.30	\$13.55	\$0.00	\$69.93
	12/01/2016	\$50.08	\$7.30	\$13.55	\$0.00	\$70.93
For apprentice rates see "Apprentice- LABORER"						
TUNNEL WORK - COMPRESSED AIR (HAZ. WASTE) <i>LABORERS (COMPRESSED AIR)</i>	06/01/2015	\$49.58	\$7.30	\$13.55	\$0.00	\$70.43
	12/01/2015	\$50.33	\$7.30	\$13.55	\$0.00	\$71.18
	06/01/2016	\$51.08	\$7.30	\$13.55	\$0.00	\$71.93
	12/01/2016	\$52.08	\$7.30	\$13.55	\$0.00	\$72.93
For apprentice rates see "Apprentice- LABORER"						
TUNNEL WORK - FREE AIR <i>LABORERS (FREE AIR TUNNEL)</i>	06/01/2015	\$39.65	\$7.30	\$13.55	\$0.00	\$60.50
	12/01/2015	\$40.40	\$7.30	\$13.55	\$0.00	\$61.25
	06/01/2016	\$41.15	\$7.30	\$13.55	\$0.00	\$62.00
	12/01/2016	\$42.15	\$7.30	\$13.55	\$0.00	\$63.00
For apprentice rates see "Apprentice- LABORER"						
TUNNEL WORK - FREE AIR (HAZ. WASTE) <i>LABORERS (FREE AIR TUNNEL)</i>	06/01/2015	\$41.65	\$7.30	\$13.55	\$0.00	\$62.50
	12/01/2015	\$42.40	\$7.30	\$13.55	\$0.00	\$63.25
	06/01/2016	\$43.15	\$7.30	\$13.55	\$0.00	\$64.00
	12/01/2016	\$44.15	\$7.30	\$13.55	\$0.00	\$65.00
For apprentice rates see "Apprentice- LABORER"						
VAC-HAUL <i>TEAMSTERS JOINT COUNCIL NO. 10 ZONE A</i>	06/01/2015	\$33.04	\$9.91	\$9.33	\$0.00	\$52.28
	08/01/2015	\$33.04	\$10.41	\$9.33	\$0.00	\$52.78
	12/01/2015	\$33.04	\$10.41	\$10.08	\$0.00	\$53.53
	06/01/2016	\$33.54	\$10.41	\$10.08	\$0.00	\$54.03
	08/01/2016	\$33.54	\$10.91	\$10.08	\$0.00	\$54.53
	12/01/2016	\$33.54	\$10.91	\$10.89	\$0.00	\$55.34
WAGON DRILL OPERATOR <i>LABORERS - ZONE 1</i>	06/01/2015	\$35.60	\$7.30	\$12.95	\$0.00	\$55.85
	12/01/2015	\$36.35	\$7.30	\$12.95	\$0.00	\$56.60
	06/01/2016	\$37.10	\$7.30	\$12.95	\$0.00	\$57.35
	12/01/2016	\$38.10	\$7.30	\$12.95	\$0.00	\$58.35
For apprentice rates see "Apprentice- LABORER"						
WASTE WATER PUMP OPERATOR <i>OPERATING ENGINEERS LOCAL 4</i>	06/01/2015	\$42.83	\$10.00	\$14.55	\$0.00	\$67.38
	12/01/2015	\$44.08	\$10.00	\$14.55	\$0.00	\$68.63
	06/01/2016	\$44.83	\$10.00	\$14.55	\$0.00	\$69.38
	12/01/2016	\$46.08	\$10.00	\$14.55	\$0.00	\$70.63
	06/01/2017	\$47.08	\$10.00	\$14.55	\$0.00	\$71.63
12/01/2017	\$48.08	\$10.00	\$14.55	\$0.00	\$72.63	
For apprentice rates see "Apprentice- OPERATING ENGINEERS"						

Classification	Effective Date	Base Wage	Health	Pension	Supplemental Unemployment	Total Rate
WATER METER INSTALLER <i>PLUMBERS & GASFITTERS LOCAL 12</i>	03/01/2015	\$50.21	\$10.32	\$14.89	\$0.00	\$75.42
	09/01/2015	\$51.21	\$10.32	\$14.89	\$0.00	\$76.42
	03/01/2016	\$52.36	\$10.32	\$14.89	\$0.00	\$77.57
	09/01/2016	\$53.41	\$10.32	\$14.89	\$0.00	\$78.62
	03/01/2017	\$54.41	\$10.32	\$14.89	\$0.00	\$79.62
For apprentice rates see "Apprentice- PLUMBER/PIPEFITTER" or "PLUMBER/GASFITTER"						
Outside Electrical - East						
CABLE TECHNICIAN (Power Zone) <i>OUTSIDE ELECTRICAL WORKERS - EAST LOCAL 104</i>	09/01/2013	\$25.66	\$8.70	\$4.48	\$0.00	\$38.84
For apprentice rates see "Apprentice- LINEMAN"						
CABLEMAN (Underground Ducts & Cables) <i>OUTSIDE ELECTRICAL WORKERS - EAST LOCAL 104</i>	09/01/2013	\$36.55	\$8.70	\$6.58	\$0.00	\$51.83
For apprentice rates see "Apprentice- LINEMAN"						
DRIVER / GROUNDMAN CDL <i>OUTSIDE ELECTRICAL WORKERS - EAST LOCAL 104</i>	09/01/2013	\$29.94	\$8.70	\$6.05	\$0.00	\$44.69
For apprentice rates see "Apprentice- LINEMAN"						
DRIVER / GROUNDMAN -Inexperienced (<2000 Hrs) <i>OUTSIDE ELECTRICAL WORKERS - EAST LOCAL 104</i>	09/01/2013	\$23.52	\$8.70	\$5.24	\$0.00	\$37.46
For apprentice rates see "Apprentice- LINEMAN"						
EQUIPMENT OPERATOR (Class A CDL) <i>OUTSIDE ELECTRICAL WORKERS - EAST LOCAL 104</i>	09/01/2013	\$36.35	\$8.70	\$9.43	\$0.00	\$54.48
For apprentice rates see "Apprentice- LINEMAN"						
EQUIPMENT OPERATOR (Class B CDL) <i>OUTSIDE ELECTRICAL WORKERS - EAST LOCAL 104</i>	09/01/2013	\$32.08	\$8.70	\$6.59	\$0.00	\$47.37
For apprentice rates see "Apprentice- LINEMAN"						
GROUNDMAN <i>OUTSIDE ELECTRICAL WORKERS - EAST LOCAL 104</i>	09/01/2013	\$23.52	\$8.70	\$3.72	\$0.00	\$35.94
For apprentice rates see "Apprentice- LINEMAN"						
GROUNDMAN -Inexperienced (<2000 Hrs.) <i>OUTSIDE ELECTRICAL WORKERS - EAST LOCAL 104</i>	09/01/2013	\$19.25	\$8.70	\$2.85	\$0.00	\$30.80
For apprentice rates see "Apprentice- LINEMAN"						
JOURNEYMAN LINEMAN <i>OUTSIDE ELECTRICAL WORKERS - EAST LOCAL 104</i>	09/01/2013	\$42.77	\$8.70	\$11.78	\$0.00	\$63.25

Apprentice - LINEMAN (Outside Electrical) - East Local 104

Effective Date - 09/01/2013

Step	percent	Apprentice Base Wage	Health	Pension	Supplemental Unemployment	Total Rate
1	60	\$25.66	\$8.70	\$4.24	\$0.00	\$38.60
2	65	\$27.80	\$8.70	\$4.71	\$0.00	\$41.21
3	70	\$29.94	\$8.70	\$5.43	\$0.00	\$44.07
4	75	\$32.08	\$8.70	\$6.16	\$0.00	\$46.94
5	80	\$34.22	\$8.70	\$6.88	\$0.00	\$49.80
6	85	\$36.35	\$8.70	\$7.62	\$0.00	\$52.67
7	90	\$38.49	\$8.70	\$8.83	\$0.00	\$56.02

Notes:

Apprentice to Journeyworker Ratio:1:2

Classification	Effective Date	Base Wage	Health	Pension	Supplemental Unemployment	Total Rate
TELEDATA CABLE SPLICER <i>OUTSIDE ELECTRICAL WORKERS - EAST LOCAL 104</i>	01/01/2015	\$28.12	\$4.25	\$3.09	\$0.00	\$35.46
	01/01/2016	\$28.98	\$4.25	\$3.12	\$0.00	\$36.35
TELEDATA LINEMAN/EQUIPMENT OPERATOR <i>OUTSIDE ELECTRICAL WORKERS - EAST LOCAL 104</i>	01/01/2015	\$26.49	\$4.25	\$3.04	\$0.00	\$33.78
	01/01/2016	\$27.31	\$4.25	\$3.07	\$0.00	\$34.63
TELEDATA WIREMAN/INSTALLER/TECHNICIAN <i>OUTSIDE ELECTRICAL WORKERS - EAST LOCAL 104</i>	01/01/2015	\$26.49	\$4.25	\$3.04	\$0.00	\$33.78
	01/01/2016	\$27.31	\$4.25	\$3.07	\$0.00	\$34.63
TREE TRIMMER <i>OUTSIDE ELECTRICAL WORKERS - EAST LOCAL 104</i>	02/01/2015	\$18.05	\$3.55	\$0.00	\$0.00	\$21.60
	01/31/2016	\$18.51	\$3.55	\$0.00	\$0.00	\$22.06
This classification applies only to tree work done: (a) for a utility company, R.E.A. cooperative, or railroad or coal mining company, and (b) for the purpose of operating, maintaining, or repairing the utility company's equipment, and (c) by a person who is using hand or mechanical cutting methods and is not on the ground. This classification does not apply to wholesale tree removal.						
TREE TRIMMER GROUNDMAN <i>OUTSIDE ELECTRICAL WORKERS - EAST LOCAL 104</i>	02/01/2015	\$15.92	\$3.55	\$0.00	\$0.00	\$19.47
	01/31/2016	\$16.32	\$3.55	\$0.00	\$0.00	\$19.87
This classification applies only to tree work done: (a) for a utility company, R.E.A. cooperative, or railroad or coal mining company, and (b) for the purpose of operating, maintaining, or repairing the utility company's equipment, and (c) by a person who is using hand or mechanical cutting methods and is on the ground. This classification does not apply to wholesale tree removal.						

Additional Apprentices Information:

Minimum wage rates for apprentices employed on public works projects are listed above as a percentage of the pre-determined hourly wage rate established by the Commissioner under the provisions of the M.G.L. c. 149, ss. 26-27D. Apprentices ratios are established by the Division of Apprenticeship Training pursuant to M.G.L. c. 23, ss. 11E-11L.

All apprentices must be registered with the Division of Apprenticeship Training in accordance with M.G.L. c. 23, ss. 11E-11L.

All steps are six months (1000 hours.)

Ratios are expressed in allowable number of apprentices to journeymen or fraction thereof, unless otherwise specified.

** Multiple ratios are listed in the comment field.

*** APP to JM; 1:1, 2:2, 2:3, 3:4, 4:4, 4:5, 4:6, 5:7, 6:7, 6:8, 6:9, 7:10, 8:10, 8:11, 8:12, 9:13, 10:13, 10:14, etc.

**** APP to JM; 1:1, 1:2, 2:3, 2:4, 3:5, 4:6, 4:7, 5:8, 6:9, 6:10, 7:11, 8:12, 8:13, 9:14, 10:15, 10:16, etc.

Appendix C – Estimated Quantities

The following unnumbered pages contain estimates of the quantities of services and materials the Town anticipates consuming during the contract period..

CONTRACT # 15-07

ROADWAY MANAGEMENT BID PRICE FORMS

Item #	Description	Est Qty	x	Bid Price	/	Unit	=	Total
120	Earth Excavation	500	x	\$	/	CY	=	\$
121	Class A Rock Excavation	10	x	\$	/	CY	=	\$
129	Bituminous Excavation by Cold Planer	10,000	x	\$	/	SY	=	\$
129.01	Bituminous Excavation by Cold Planer (9AM to 3PM)	9,500	x	\$	/	SY	=	\$
129.02	Bituminous Excavation by Cold Planer (4" Depth)	7,500	x	\$	/	SY	=	\$
129.1	Bituminous Excavation by Cold Planer (Keyways)	300	x	\$	/	SY	=	\$
141.1	Test Pit for Exploration	10	x	\$	/	CY	=	\$
142	Class B Trench Excavation	*	x	\$	/	CY	=	*****No Value*****
144	Class B Rock Excavation	*	x	\$	/	CY	=	*****No Value*****
151	Gravel Borrow	525	x	\$	/	CY	=	\$
153	Controlled Density Fill	5	x	\$	/	CY	=	\$
170	Fine Grading and Compacting	3,640	x	\$	/	SY	=	\$
187.3	Removal and Disposal of Drainage Structure Sediment	*	x	\$	/	CY	=	*****No Value*****
201	Catch Basin	1	x	\$	/	EA	=	\$
202	Manhole	1	x	\$	/	EA	=	\$
202.2	Manhole (9-14 feet depth)	*	x	\$	/	EA	=	*****No Value*****

Item #	Description	Est Qty	x	Bid Price	/	Unit	=	Total
202.3	Manhole (14-18 feet depth)	*	x	\$	/	EA	=	*****No Value*****
204	Gutter Inlet	1	x	\$	/	EA	=	\$
205	Leaching Basin	1	x	\$	/	EA	=	\$
220.1.1	Drainage Structure Adjusted (Greater than 6" Vertical)	19	x	\$	/	EA	=	\$
220.1.2	Drainage Structure Adjusted (Less than 6" Vertical)	38	x	\$	/	EA	=	\$
220.2	Drainage Structure Rebuilt	66	x	\$	/	VFt	=	\$
220.3	Drainage Structure Change in Type	1	x	\$	/	EA	=	\$
220.5	Drainage Structure Remodeled	1	x	\$	/	EA	=	\$
220.7.1	Sanitary Structure Adjusted (Greater than 6" Vertical)	23	x	\$	/	EA	=	\$
220.7.2	Sanitary Structure Adjusted (Less than 6" Vertical)	43	x	\$	/	EA	=	\$
220.8	Sanitary Structure Remodeled	1	x	\$	/	EA	=	\$
221	Frame and Cover	10	x	\$	/	EA	=	\$
222	Frame and Grate	6	x	\$	/	EA	=	\$
222.1	Frame and Grate MHD Cascade Type	18	x	\$	/	EA	=	\$
223	Frame and Grate (or Cover) Removed and Reset	66	x	\$	/	EA	=	\$
238.12	12" Ductile Iron Pipe	20	x	\$	/	LF	=	\$
244.12	12" Reinforced Concrete Pipe Class V	20	x	\$	/	LF	=	\$
252.12	12" Corrugated Plastic Pipe	20	x	\$	/	LF	=	\$

Item #	Description	Est Qty	x	Bid Price	/	Unit	=	Total
258	Stone for Pipe Ends	10	x	\$	/	SY	=	\$
269.06	6" Slot Perforated Corrugated Plastic Pipe (Subdrain)	600	x	\$	/	LF	=	\$
269.08	8" Slot Perforated Corrugated Plastic Pipe (Subdrain)	50	x	\$	/	LF	=	\$
357	Gate Box	62	x	\$	/	EA	=	\$
358.1	Gate Box Adjusted (Greater than 6" Vertical)	56	x	\$	/	EA	=	\$
358.2	Gate Box Adjusted (Less than 6" Vertical)	44	x	\$	/	EA	=	\$
381	Service Box	58	x	\$	/	EA	=	\$
381.3	Service Box Adjusted	125	x	\$	/	EA	=	\$
402	Dense Graded Crushed Stone for Sub-Base	20	x	\$	/	CY	=	\$
402.12	Dense Graded Crushed Stone for Shoulders	20	x	\$	/	CY	=	\$
403	Reclaimed Base Course and/or Sub-Base	*	x	\$	/	SY	=	*****No Value*****
403.1	Crushed Stone for Blending	20	x	\$	/	Ton	=	\$
420	Class I Bituminous Concrete Base Course Type I-1	*	x	\$	/	Ton	=	***** No Value*****
440	Calcium Chloride for Roadway Dust Control	50	x	\$	/	Lb	=	\$
442	Liquid Calcium Chloride for Blending	*	x	\$	/	Gal	=	*****No Value*****
443	Water for Roadway Dust Control (per 1000 Gallons)	1	x	\$	/	Mgal	=	\$
460	Class I Bituminous Concrete Pavement Type I-1	8850	x	\$	/	Ton	=	\$
464	Bitumen for Tack Coat	1810	x	\$	/	Gal	=	\$

Item #	Description	Est Qty	x	Bid Price	/	Unit	=	Total
464.5	Hot Poured Rubberized Asphalt Crack Filler (Polyester)	100	x	\$	/	LF	=	\$
472	Patching	200	x	\$	/	Ton	=	\$
472.4	Grind and Inlay	50	x	\$	/	SY	=	\$
482.15	Hot Applied Asphalt Crack Filler (Polyester)	100	x	\$	/	Gal	=	\$
483.5	Sawcutting Pavement and Concrete	5000	x	\$	/	LF	=	\$
504	Granite Curb Type VA-4 - Straight	3100	x	\$	/	LF	=	\$
504.1	Granite Curb Type VA-4 - Curved	50	x	\$	/	LF	=	\$
506	Granite Curb Type VB - Straight	*	x	\$	/	LF	=	*****No Value*****
506.1	Granite Curb Type VB - Curved	*	x	\$	/	LF	=	*****No Value*****
509	Granite Transition Curb for Wheelchair Ramp - Straight	50	x	\$	/	LF	=	\$
509.1	Granite Transition Curb for Wheelchair Ramp - Curved	190	x	\$	/	LF	=	\$
511.1	Granite Edging Type SB - Straight	250	x	\$	/	LF	=	\$
516	Granite Curb Corner - Type A	240	x	\$	/	EA	=	\$
520	Concrete Curb - Type VA	*	x	\$	/	LF	=	*****No Value*****
570.1	Bituminous Concrete Curb - Type 1	*	x	\$	/	LF	=	***** No Value*****
570.2	Bituminous Concrete Curb - Type 2	1100	x	\$	/	LF	=	\$
570.3	Bituminous Concrete Curb - Type 3	*	x	\$	/	LF	=	***** No Value*****
580	Curb Remove and Reset	300	x	\$	/	LF	=	\$

Item #	Description	Est Qty	x	Bid Price	/	Unit	=	Total
582	Curb Corner Remove and Reset	10	x	\$	/	EA	=	\$
670	Fence Remove and Reset	*	x	\$	/	LF	=	***** No Value *****
697	Sedimentation Fence	*	x	\$	/	LF	=	***** No Value *****
701	Concrete Sidewalk	1250	x	\$	/	SY	=	\$
701.01	Color Additive for Cement Concrete - Gray	*	x	\$	/	SY	=	***** No Value *****
701.1	Concrete Driveway	1450	x	\$	/	SY	=	\$
701.2	Concrete Wheelchair Ramp	940	x	\$	/	SY	=	\$
702	Bituminous Concrete Walk Surface	50	x	\$	/	Ton	=	\$
702.1	Excavation and Disposal of Existing Sidewalk	3640	x	\$	/	SY	=	\$
703	Bituminous Concrete Driveways (Handwork)	300	x	\$	/	Ton	=	\$
706.1	Remove and Reset Brick Walk per Arlington Spec	*	x	\$	/	SY	=	*****No Value*****
706.1.2	Install New Brick Sidewalk per Arlington Spec	*	x	\$	/	SY	=	*****No Value*****
715	Rural Mailbox Remove and Reset	*	x	\$	/	EA	=	***** No Value*****
751	Loam Borrow	475	x	\$	/	CY	=	\$
765	Seeding	1550	x	\$	/	SY	=	\$
767.4	Wood Chip Mulch	*	x	\$	/	CY	=	*****No Value*****
767.8	Bales of Hay for Erosion Control	*	x	\$	/	EA	=	***** No Value*****
811.36	Electric/Telecom Manhole Adjusted (Less than 6")	6	x	\$	/	EA	=	\$

Item #	Description	Est Qty	x	Bid Price	/	Unit	=	Total
819.831	Wire Loop Installed in Roadway	*	x	\$	/	LF	=	*****No Value*****
832	Warning Regulatory Aluminum Panel Sign (Type A)	*	x	\$	/	SF	=	***** No Value*****
847.1	Sign Support with 1 Breakaway Post (Steel)	*	x	\$	/	EA	=	*****No Value*****
854.014	Temporary Pavement Markings - 4" Painted	7600	x	\$	/	LF	=	\$
854.034	Temporary Pavement Markings - 4" Removable Tape	100	x	\$	/	LF	=	\$
865.12	Portable Changeable Message Board	*	x	\$	/	Day	=	*****No Value*****
861.04	Reflectorized Yellow Line - 4" Painted	4400	x	\$	/	LF	=	\$
861.04	Reflectorized Yellow Line - 4" Painted	4400	x	\$	/	LF	=	\$
868.04	Reflectorized White Line - 4" EPOXY	7600	x	\$	/	LF	=	\$
868.12	Reflectorized White Line - 12" EPOXY	800	x	\$	/	LF	=	\$
869.04	Reflectorized Yellow Line - 4" EPOXY	7600	x	\$	/	LF	=	\$
874.1	Sign Removed and Reset	20	x	\$	/	EA	=	\$

BID TOTAL

\$

Appendix D – Example MBE/WBE Letters of Intent & Schedules of Participation

IMPORTANT! THE FOLLOWING MBE/WBE FORMS ARE EXAMPLES ONLY. DO NOT SUBMIT WITH BID.

Low bidders who accept contract awards will be required to comply with any and all Minority Business Enterprise [MBE] and Women's Business Enterprise [WBE] policies and participation goals of the contracting municipality. Bidders must submit any required MBE/WBE Forms/Letter of Intent & Schedules of Participation required by a municipality for acceptance prior to beginning any scheduled work. The following are examples of forms currently in use and which a contractor may be required to submit to the town.

BY-LAWS OF THE TOWN OF ARLINGTON

TITLE I

ARTICLE 16

CONSTRUCTION PROJECTS

Section 1. Women Work Force Participation

Any Town board or official in charge of a construction or reconstruction project is required to include in the contract documents the following:

- A. Contractor shall maintain as a goal on this project a not less than five percent ratio of women work force to total project hours in both the general contract and each individual filed sub-bid contract, if applicable. The preceding sentence shall be included in all construction contracts whether entered into by the Town pursuant to the provisions of M.G.L. c. 149 or M.G. L. c 30, §39M et. seq. provided however, that if entered into under Chapter 30 same shall not be deemed to apply where the projected bid price as determined by the Director of Public Works is not likely to exceed \$200,000.
- B. A Labor Scheduling Table which will be used as a tool for achieving a range of women work force participation for the entire project in both the general contract and each individual filed sub-bid contract.

Section 2. Equal Opportunity Goal Compliance

Any Town board or official in charge of a construction or reconstruction project is required to include in the contract documents the following:

- A. Before starting work, the contractors (includes the general contractor, for itself and its subcontractors, as well as all filed sub-bid contractors, if applicable) will submit plans for achievement of the equal opportunity goals of the contract. All contractors will be required to make a good faith effort to achieve these goals. The plan will indicate if the contractors expect to achieve the requirements during the first quarter. If there are reasons why the contractors do not expect to achieve the requirements during the first quarter year of the contract construction phase, then the contractors shall provide a plan calculated to address, to the extent reasonably possibly, these obstacles to a good faith effort to achieve such goals.
- B. Not more than ten days following the end of each work quarter, the contractors will report on the achievement of the goals, detailing the good faith efforts that have been made and will continue to be made and any other appropriate efforts not yet undertaken.
- C. All reports will be signed by an officer or principal of the company who has the authority to contractually obligate the company.

Section 3. Recruitment and Training

Any board, officer, committee, or other agency of the Town, which acts on behalf of the Town in making or supervising any contract, in an amount exceeding the sum of \$100,000 for the purchase of goods or services or for the construction, renovation, or repair of buildings or other improvement of real estate, may make arrangements with contractors and other interested agencies for special programs of recruitment and training in connection with the work to be performed on such contract, with the objective of promoting equal employment opportunity for members of minority groups protected by the fair employment laws of the Commonwealth and the United States. Any board, officer, committee or other Town agency may expend Town funds in carrying them out provided that appropriations specifically designed for such purposes have been voted by the Town Meeting.

**MINORITY BUSINESS PARTICIPATION
LETTER OF INTENT**

The undersigned intends to perform work in connection with the above project as (check one) *:

- an individual c
- partnership c
- corporation c
- joint venture

The minority status of the undersigned is (a) certified by the State Office of Minority Women Business Assistance [SOMWBA] or (b) has applied for certification on the attached Minority Business Certification Application.

The undersigned is prepared to perform the following described work in connection with the above project. (Specify in detail particular work items or parts thereof to be performed.) *

at the following price*: _____.

You have projected the following commencement date for such work, and the undersigned is projecting completion of such work as follows:

<u>Items</u>	<u>Projected Commencement</u>	<u>Projected Date</u>	<u>Completion Date</u>

The above work will not be subcontracted to a non-minority business. The undersigned will enter into a formal agreement with you for the above work conditions upon your execution of a contract for the above project.

Date: _____

Name of Minority Business

**WOMEN BUSINESS PARTICIPATION
LETTER OF INTENT**

The undersigned intends to perform work in connection with the above project as (check one):

- an individual c
- partnership c
- corporation c
- joint venture

The minority status of the undersigned is (a) certified by the State Office of Minority Women Business Assistance [SOMWBA] or (b) has applied for certification on the attached Minority Business Certification Application.

The undersigned is prepared to perform the following described work in connection with the above project. (Specify in detail particular work items or parts thereof to be performed.)

at the following price: _____.

You have projected the following commencement date for such work, and the undersigned is projecting completion of such work as follows:

<u>Items</u>	<u>Projected Commencement</u>	<u>Projected Date</u>	<u>Completion Date</u>

The above work will not be subcontracted to a non-minority business. The undersigned will enter into a formal agreement with you for the above work conditions upon your execution of a contract for the above project.

Date: _____

Name of Minority Business

**SCHEDULE FOR PARTICIPATION BY
WOMEN BUSINESS ENTERPRISES**

Name of Minority
Business Enterprise

Total
Price

Total Bid Amount _____

Total amount to be paid to Women Business Enterprises _____

PERCENT OF TOTAL BID PRICE WHICH IS TO BE PAID TO WOMEN BUSINESS ENTERPRISES FOR WORK
PERFORMED UNDER THIS CONTRACT _____

Appendix E – MassDOT Price Adjustment Clauses

DOCUMENT 00812

SPECIAL PROVISIONS
MONTHLY PRICE ADJUSTMENT FOR DIESEL FUEL AND GASOLINE –
ENGLISH UNITS

Revised: 01/26/2009

This monthly fuel price adjustment is inserted in this contract because the national and worldwide energy situation has made the future cost of fuel unpredictable. This adjustment will provide for either additional compensation to the Contractor or repayment to the Commonwealth, depending on an increase or decrease in the average price of diesel fuel or gasoline.

This adjustment will be based on fuel usage factors for various items of work developed by the Highway Research Board in Circular 158, dated July 1974. These factors will be multiplied by the quantities of work done in each item during each monthly period and further multiplied by the variance in price from the Base Price to the Period Price.

The Base Price of Diesel Fuel and Gasoline will be the price as indicated in the Department's web site (www.mhd.state.ma.us) for the month in which the contract was bid, which includes State Tax.

The Period Price will be the average of prices charged to the State, including State Tax for the bulk purchases made during each month.

This adjustment will be effected only if the variance from the Base Price is 5% or more for a monthly period. The complete adjustment will be paid in all cases with no deduction of the 5% from either upward or downward adjustments.

No adjustment will be paid for work done beyond the extended completion date of any contract.

Any adjustment (increase or decrease) to estimated quantities made to each item at the time of final payment will have the fuel price adjustment figured at the average period price for the entire term of the project for the difference of quantity.

The fuel price adjustment will apply only to the following items of work at the fuel factors shown:

ITEMS COVERED	FUEL FACTORS	
	Diesel	Gasoline
Excavation: and Borrow Work: Items 120, 120.1, 121, 123, 124, 125, 127, 129.3, 140, 140.1, 141, 142, 143, 144., 150, 150.1, 151 and 151.1 (Both Factors used)	0.29 Gallons / CY.	0.15 Gallons / CY
Surfacing Work: All Items containing Hot Mix Asphalt	2.90 Gallons / Ton	Does Not Apply

***** END OF DOCUMENT *****

DOCUMENT 00811
SPECIAL PROVISIONS
MONTHLY PRICE ADJUSTMENT FOR HOT MIX ASPHALT (HMA) MIXTURES
ENGLISH UNITS
Revised: 02/02/2009

This provision applies to all projects using greater than 100 tons of hot mix asphalt (HMA) mixtures containing liquid asphalt cement as stipulated in the Notice to Contractors section of the bid documents.

The Price Adjustment will be based on the variance in price for the liquid asphalt component only from the Base Price to the Period Price. It shall not include transportation or other charges. This Price Adjustment will occur on a monthly basis.

Base Price

The Base Price of liquid asphalt on a project as listed in the Notice to Contractors section of the bid documents is a fixed price determined at the time of bid by the Department by using the same method as for the determination of the Period Price detailed below.

Period Price

Please note that, starting December 15, 2008, two sets of period prices will be posted each month on the MassHighway website at <http://www.mhd.state.ma.us/>. They will be labeled "New Asphalt Period Price Method" and "Old Asphalt Period Price Method".

New Asphalt Period Price Method

The "New Asphalt Period Price Method" is for contracts bid after December 15, 2008 and will show the Period Price of liquid asphalt for each monthly period as determined by MassHighway using the average selling price per standard ton of PG64-28 paving grade (primary binder classification) asphalt, FOB manufacturer's terminal, as listed under the "East Coast Market - New England, Boston, Massachusetts area" section of the Poten & Partners, Inc. "Asphalt Weekly Monitor". This average selling price is listed in the issue having a publication date of the second Friday of the month and will be posted as the Period Price for that month. MassHighway will post this Period Price on this website within two (2) business days following their receipt of the relevant issue of the "Asphalt Weekly Monitor". Poten and Partners has granted MassHighway the right to publish this specific asphalt price information sourced from the Asphalt Weekly Monitor.

Old Asphalt Period Price Method

The "Old Asphalt Period Price Method" Period Price will be for contracts bid on or before December 15, 2008 and will contain liquid asphalt prices as determined by the old or previous method. These prices will continue to be posted on MassHighway's website until all contracts using the "Old Asphalt Period Price Method" Period Price have been closed.

New and Old Asphalt Period Price Methods

The paragraphs below apply to both the New and the Old Asphalt Period Price Methods.

The Contract Price of the hot mix asphalt mixture will be paid under the respective item in the Contract. The price adjustment, as herein provided, upwards or downwards, will be made after the work has been performed, using the monthly period price for the month during which the work was performed.

The Price Adjustment applies only to the actual virgin liquid asphalt content in the mixture placed on the job in accordance with the Standard Specifications for Highways and Bridges, Division III, Section M3.11.03.

The Price Adjustment will be a separate payment item. It will be determined by multiplying the number of tons of hot mix asphalt mixtures placed during each monthly period times the liquid asphalt content percentage times the variance in price between Base Price and Period Price of liquid asphalt.

This Price Adjustment will be paid only if the variance from the Base Price is 5% or more for a monthly period. The complete adjustment will be paid in all cases with no deduction of the 5% from either upward or downward adjustments.

No Price Adjustment will be allowed beyond the Completion Date of this Contract, unless there is a Department-approved extension of time.

***** END OF DOCUMENT *****

DOCUMENT 00814

SPECIAL PROVISIONS
PRICE ADJUSTMENT FOR PORTLAND CEMENT CONCRETE MIXES

January 12, 2009

This provision applies to all projects using greater than 100 Cubic Yards (76 Cubic Meters) of Portland cement concrete containing Portland cement as stipulated in the Notice to Contractors section of the Bid Documents. This Price Adjustment will occur on a monthly basis.

The Price Adjustment will be based on the variance in price for the Portland cement component only from the Base Price to the Period Price. It shall not include transportation or other charges.

The Base Price of Portland cement on a project is a fixed price determined at the time of bid by the Department by using the same method as for the determination of the Period Price (see below) and found in the Notice to Contractors.

The Period Price of Portland cement will be determined by using the latest published price, in dollars per ton (U.S.), for Portland cement (Type I) quoted for Boston, U.S.A. in the **Construction Economics** section of *ENR Engineering News-Record* magazine or at the ENR website <http://www.enr.com> under **Construction Economics**. The Period Price will be posted on the MassHighway website the Wednesday immediately following the publishing of the monthly price in ENR, which is normally the first week of the month.

The Contract Price of the Portland cement concrete mix will be paid under the respective item in the Contract. The price adjustment, as herein provided, upwards or downwards, will be made after the work has been performed, using the monthly period price for the month during which the work was performed.

The price adjustment applies only to the actual Portland cement content in the mix placed on the job in accordance with the Standard Specifications for Highways and Bridges, Division III, Section M4.02.01. No adjustments will be made for any cement replacement materials such as fly ash or ground granulated blast furnace slag.

The Price Adjustment will be a separate payment item. It will be determined by multiplying the number of cubic yards of Portland cement concrete placed during each monthly period times the Portland cement content percentage times the variance in price between the Base Price and Period Price of Portland cement.

This Price Adjustment will be paid only if the variance from the Base Price is 5% or more for a monthly period. The complete adjustment will be paid in all cases with no deduction of the 5% from either upward or downward adjustments.

No Price Adjustment will be allowed beyond the Completion Date of this Contract, unless there is a Department-approved extension of time.

*

END OF DOCUMENT

DOCUMENT 00813

SPECIAL PROVISIONS
PRICE ADJUSTMENT FOR STRUCTURAL STEEL AND REINFORCING STEEL
ENGLISH UNITS

December 1, 2008

This provision only applies to those projects that contain Price Adjustments for all structural steel and reinforcing steel as stipulated in the Notice to Contractors. When used, this provision applies to all structural steel and reinforcing steel. This provision does not apply to sole, masonry, and shim plates, bolts, pins, welds, or other miscellaneous steel. Price Adjustments will occur after submittal by the Contractor to the Department of certified paid mill invoices for the Contractor's purchase of unfabricated structural steel material, including, but not limited to, rolled shapes, plate steel, sheet piling, pipe piles, steel castings, steel forgings, guardrail, and unfabricated reinforcing steel bars.

Base Prices and Mill Prices shall be defined as follows:

Base Prices of unfabricated structural steel material and unfabricated reinforcing steel bars on a project are fixed prices determined by the Department and found in the Notice to Contractors.

Base Mill Prices of unfabricated structural steel material and unfabricated reinforcing steel bars on a project are the actual prices paid by the Contractor to a steel mill for this material and contained in certified paid invoices submitted to the Department by the Contractor.

Price Adjustments will be variances between Base Prices and Mill Prices.

Price Adjustments will *not* include the costs of shop drawing preparation, handling, fabrication, coatings, transportation, storage, installation, profit, overhead, fuel surcharges, or other such charges not related to the cost of the unfabricated structural or reinforcing steel itself. The invoiced weight of steel shall not exceed the final shipping weight of the fabricated part by more than 10%.

The Contractor will be paid for fabricated structural steel or fabricated reinforcing steel under the respective contract pay items for all components constructed of either structural steel or reinforced portland cement concrete.

Price Adjustments, as herein provided for and adjusted either upwards or downwards, will be paid separately. Price Adjustments will be determined by multiplying the number of pounds of structural steel material or unfabricated reinforcing steel bars contained in the Contractor's certified paid invoice by the variance between the Base Price and the Mill Price of the structural steel material or unfabricated reinforcing steel bars.

The Base Mill Price shall be contained in a certified paid invoice submitted by the Contractor to the Department as part of a notarized affidavit clearly stating the weight of material and the price paid to the steel mill for the structural steel material or unfabricated reinforcing steel bar.

Price Adjustments will be made only if variances between Base Prices and Base Mill Prices are 5% or more. Once the 5% threshold has been achieved, the adjustment will apply to the full variance from the Base Price.

No Price Adjustment will be made after the contract completion date, unless the Department has approved an extension of contract time for that contract.

END OF DOCUMENT

Invitation for Bid (IFB)
Bid #15-07
Specifications For
Roadway Management/Various Locations

Town of Arlington

Table of Contents

Specifications3
Item 1 Roadway Management4
Appendix A..... 34
Attachment 1.....36
Attachment 2A40
Attachment 2B.....41
Attachment 3..... 42

Specifications

Item 1 Roadway Management

GENERAL INFORMATION

General Eligibility Criteria

Bidders must be pre-qualified by the Massachusetts Highway Department (MHD) to bid on this project and must provide a MHD Certificate of Approval in order to obtain this specific Invitation for Bids.

Pricing

Bid Item numbers reference MHD Standard Specifications Numerical Index of Payment Items. Mobilization and safety signage for construction operations shall be considered part of, and should be included as, part of every item.

Bituminous concrete prices shall include all costs associated with producing, delivering, applying and finishing the work, unless otherwise specified.

Tonnages shall be based upon weight slips specific to each load presented to and signed by the "DPW Agent"¹ at the time and site of application. Only automated printed tonnage slips will be accepted.

Quantities measured other than by weight are subject to signed verification of the DPW Agent.

Renting Equipment

Prices for hourly rental of work-related machinery, operator and fuel are called for in anticipation of unforeseen circumstances that may arise necessitating the use of special equipment to work in conjunction with Town forces. Such rentals are not to be included with Unit Bid Prices that total into the Award amount.

Direction and Oversight of the Work

All supervision and direction of the Work, all authorizations of variance from specifications, and all field decisions of the Town shall be communicated to the Contractor by the DPW Agent, also referred to as the "Town".

Miscellaneous Provisions

The Town of Arlington will pay for police traffic safety and fire details that may be required.

¹ The "DPW Agent" is the person authorized to act on behalf of the Town in relation to the performance of work subject to this specification. Such person(s) may vary in name and title from day to day, but shall always be whoever is designated by the Public Works department head and made known to the Contractor.

The Contractor will make every effort to avoid damaging abutting property. The Contractor will restore such property damaged by his equipment or personnel to its pre-damage condition, or if so determined by the Town, restoration will be done by others at the Contractor's expense.

WORK SPECIFICATIONS

Location of Project

The work to be performed is located in various areas throughout the Town of Arlington

Scope of Work

The work under this contract consists of furnishing all necessary labor, materials, equipment and services to complete roadway improvements. Work includes, but is not limited to mobilization; pavement reclamation; grading and/or relocating sections of existing roadway; earth excavation; installing, adjusting, and/or remodeling drainage, sewer & water structures; installation of bituminous concrete pavement, berm, sidewalks; installation of concrete sidewalks; line painting; crack sealing; landscaping; and other miscellaneous and incidental work items necessary to complete the work.

All materials and work under this contract shall be in conformance with the latest Editions of:

- Massachusetts Highway Department's (MHD) Standard Specifications for Highways and Bridges, Supplemental Specifications, and Standard Special Provisions
- Construction and Traffic Standard Details
- The Manual on Uniform Traffic Control Devices
- Massachusetts Highway Department's (MHD) Wheel Chair Ramp Standard
- The American Water Works Association's Standard for the Installation of Ductile-Iron Water Mains and Their Appurtenances
- The Standard Drawings for Signs and Support
- *and* the following Special Provisions contained herein and attached MHD Constructions Details for Handicap Ramps and Bituminous Concrete Berm.

SPECIAL PROVISIONS**DIVISION I - GENERAL REQUIREMENTS AND COVENANTS****SUBSECTION 5.07 CONSTRUCTION (STAKES) STAKINGS**

Replace this entire subsection with the following:

The Town will furnish general benchmark control for the project.

The Contractor, at his/her own expense, will furnish the following survey work:

- A. Establishment of base lines or centerlines of construction for main roadways, ramp service roads, side streets and other major dry land items. Reproduction of base lines and centerlines, or lines offset to them when roadway cuts and fills have been completed. Levels may be taken on the points marking these lines.
- B. Original grade stakes at 50' intervals giving finished grades as per plan.
- C. Preliminary and final surveys of pits (if borrow is paid by pit measure) and dredging areas, semifinal cross sections on ledge, peat, loam, etc.
- D. Control for structures, which shall consist of range lines on centerline of bearings or centerline of piers, face of abutments and wingwalls, horizontal and vertical control for beam seats, along with benchmarks close to structures for vertical control. Structures shall include but shall not be limited to bridges, culverts, dams, buildings and walls.
- E. Control for alignment of curbing or edging on ramps and at other complicated locations.
- F. Bound points and sideline stakes.
- G. All necessary stakes for pipes and head walls, and establish all catch basin and manhole locations as to line and grade.

The Contractor shall employ qualified engineering personnel to insure adequate control and shall furnish and set stakes of the quality used by the Department for control staking. Rough stakes may be used to denote top and bottom of slopes, edge of pavement, gutter lines, etc.

The Contractor shall furnish and set, at his/her own expense, all stakes (such as batter boards, slope stakes, pins, offset stakes, etc.) required for the construction operations and he shall be solely responsible for the accuracy of the line and grade of all features of his/her work.

The Contractor shall be held responsible for the preservation of all stakes and marks. If any of such stakes or marks are disturbed or destroyed the cost of replacing them shall be at the contractor's expense.

SPECIAL PROVISIONS

DIVISION II – CONSTRUCTION DETAILS

SECTION 120 EXCAVATION

SUBSECTION 120.21 EARTH EXCAVATION

Add the following at the end of the second paragraph:

Earth excavation shall also include as incidental to the general work, the removal and disposal of structures, pipes, gate boxes, service boxes, fences, or other items not paid for separately within the contract.

SUBSECTION 120.66 ASPHALT PAVEMENT EXCAVATION BY COLD PLANER

Add the following to the end of the subsection: See also Appendix A

Keyways shall transition from a reveal of 1 1/2" to 0" and have a width varying between 4' to 10' as directed by the resident engineer. Keyways shall be cut after binder course is laid.

Excess scarified and reclaimed material will become the property of the contractor and will be disposed of off-site. The Contractor will be responsible for damage to existing castings resulting from his operation unless such castings (water gates e.g.) have previously been paved over and are therefore not visible on surface.

SUBSECTION 120.82 PAYMENT ITEMS

Add the following payment item in numerical order:

ITEM 129.1	Asphalt Pavement Excavation by Cold Planer (Keyways)	Square Yard
ITEM 129.01	Asphalt Pavement Excavation by Cold Planer (9AM to 3PM)	Square Yard
ITEM 129.02	Asphalt Pavement Excavation by Cold Planer (4" Depth)	Square Yard

Insert the following new section in numerical order:

SECTION 130 STREET SWEEPING

DESCRIPTION

SUBSECTION 130.20 GENERAL

Street sweeping shall be by mechanical street sweeper vehicle to clear the paved surface of all debris, to the extent as determined by the Engineer.

CONSTRUCTION METHODS

SUBSECTION 130.60 GENERAL

The timing of the street sweeping operation should be such that the road remains sufficiently clean between the completion of the sweeping and the start of any reclamation and/or repaving. Should the Engineer decide that the road surface requires additional sweeping no additional compensation shall be offered the Contractor to complete this process.

No additional compensation will be allowed when street sweeping operations are used as a means of clearing off and/or exposing areas of pavement covered with vegetation or debris.

SUBSECTION 130.61 DISPOSAL

All material collected from the street sweeping process shall be disposed of by the contractor outside and away from the limits of the project with no additional measurement or payment to be made.

COMPENSATION

SUBSECTION 130.81 BASIS OF PAYMENT

There shall be no separate payment for street sweeping. Payment for such work shall be included in the various hot mix asphalt items.

SECTION 140 EXCAVATION FOR STRUCTURES

SUBSECTION 140.62 CLASS B ROCK EXCAVATION

Add the following at the end of this subsection:

The Contractor shall conduct his operations so that no disturbance or damage shall be done to utilities, wells, equipment, buildings, or structures, and shall be fully responsible for determining the methods and controls necessary to do so. If blasting is used for rock excavation, the following requirements shall be adhered to:

1. The Contractor shall conduct a preconstruction survey prior to the start of any test blasting or blasting. The Contractor shall engage the services of a recognized and acceptable vibration/blasting consultant and other experts, who shall have a minimum of 10 years experience in their specialty, to conduct a preconstruction survey.

The preconstruction survey shall be made of all properties, buildings, and other structures and utilities within 100 ft. of the centerline of the trench, where blasting is used. At a minimum, six 8 inch by 10 inch glossy color photographs shall be taken by a professional photographer at each structure in the preconstruction survey area. Three copies of each photograph shall be submitted to the Engineer 21 days prior to the start of any blasting work.

2. Prior to production blasting, the Contractor shall employ an acceptable, independent, vibration/blasting consultant to conduct test blasting to develop control procedures for production blasting so that no disturbance or damage shall be done. The vibration/blasting consultant shall be a Registered Professional Engineer in the Commonwealth of Massachusetts and shall have a minimum of 10 years experience as a vibration/blasting consultant. The Contractor shall submit the name of the vibration/blasting consultant to the Engineer prior to starting the work.
3. Based on the results of the test blasting, the vibration/blasting consultant shall develop a suitable blasting program and distance-quantity of explosive tables for the production blasting. The blasting program and the distance-quantity tables shall be submitted to the Engineer 21 days prior to the commencement of production blasting. All production blasting operations shall be in accordance with the blasting program.
4. The vibration/blasting consultant shall also perform continuous monitoring of all blasting operations. Blasting shall be monitored with a minimum of two 3 component seismometers that record the entire particle velocity wave train and not just peak velocities. Accurate, legible seismometer records of all monitored blasts shall be obtained and one copy of all blast records shall be submitted to the Engineer within 7 days after blasting. Peak particle velocities exceeding 2-inch per second at a distance of 50-feet from the centerline of the trench will not be permitted.

If evidence of disturbance or damage to any utility, well, equipment, building, or structure is observed or reported to the Contractor, he shall immediately notify the Engineer, and all blasting operations shall be discontinued, and the Contractor's vibration/blasting consultant shall recommend revised blasting procedures. Blasting may then continue following revised blasting procedures.

The Contractor shall be fully responsible for the restoration or replacement of all utilities, wells, equipment, buildings, or structures damaged by his operations at no cost to the Owner.

A Town Fire Detail shall be present on site during all blasting operations, as well as any time explosives are on site, as stated in Subsection 850.38.

SUBSECTION 140.81 BASIS OF PAYMENT

Add the following at the end of the 11th paragraph of this subsection:

The minimum bid for Class B Rock Excavation shall be \$35.00 per cubic yard and shall be considered full compensation for all work associated with Class B Rock Excavation, including pre-construction survey and monitoring program, blasting, and all other work associated with the excavation and disposal of the rock.

SECTION 150 EMBANKMENT

SUBSECTION 150.64 BACKFILLING FOR STRUCTURES AND PIPES, (A. GENERAL)

Replace the 2nd sentence of this subsection with the following:

When suitable backfill material cannot be obtained from excavation, gravel borrow shall be used.

SUBSECTION 150.64 BACKFILLING FOR STRUCTURES AND PIPES, (C. PIPES)

Replace the last paragraph of this subsection with the following:

In all cases the filling material shall be thoroughly compacted by means of a mechanical compactor. In addition, compaction testing will be done by the Town on each 6-inch lift with a minimum compaction of 95% of dry soil density based on ASTM D1557 Modified Proctor Analysis. Said testing will be done by nuclear densometer in accordance with ASTM D2922.

The Town shall cover all costs associated with the actual testing of the material. No compensation shall be made for any delays due to compaction testing.

SUBSECTION 150.80 METHOD OF MEASUREMENT

Add the following after the 9th paragraph of this section:

Crushed Stone (¾") when used for pipe bedding shall be included in the item price for the associated pipe, with no separate measurement or payment.

Insert the following new section in numerical order:

SECTION 153 CONTROLLED DENSITY FILL

SUBSECTION 153.20 GENERAL

Excavatable Controlled Density Fill (CDF) shall be used as backfill material in utility trenches, abandoned structures and other locations as determined by the Engineer.

SUBSECTION 153.40 MATERIALS

Materials shall meet the requirements specified in the following subsection of Division III, Materials:

Controlled Density Fill, Type 2E M4.08.0

SUBSECTION 153.60 CONSTRUCTION METHODS

Controlled Density Fill shall be placed in a manner such that no damage will occur to utility lines, pipes or structures. The material shall be placed so that no voids are left upon completion of the backfilling process.

SUBSECTION 153.80 METHOD OF MEASUREMENT

Controlled Density Fill shall be measured in place by the cubic yard.

SUBSECTION 153.81 BASIS OF PAYMENT

Payment for Controlled Density Fill will be paid for at the contract unit price per cubic yard. No additional compensation shall be offered for material placed beyond the limits of excavation as shown in the plans or as determined by the Engineer.

SUBSECTION 153.82 PAYMENT ITEMS

ITEM 153 Controlled Density Fill – Excavatable Cubic Yard

Insert the following new section in numerical order:

SECTION 187 REMOVAL AND DISPOSAL OF DRAINAGE STRUCTURE SEDIMENTS

SUBSECTION 187.20 GENERAL

The work under this item shall include removing the accumulated dirt, refuse, and other debris from existing drainage structures, including the gutter mouth of curb inlets, and disposing of materials removed. Identification of drainage structures requiring sediment removal shall be at the direction of the resident engineer.

SUBSECTION 187.60 CONSTRUCTION METHODS

The cast hood shall be removed from all catch basins so equipped, prior to cleaning.

Hydraulic lift trucks shall be used during drainage structure cleaning operations so that the material can be decanted at the site. After material from several drainage structures along the same system is loaded onto the truck, the truck should be elevated so any free flowing liquid may drain back into the drainage structure. Material must arrive at the facility sufficiently dry to pass the Paint Filter Liquids Test (or no liquid drips from it when a handful is taken and squeezed).

All material removed from drainage structures shall be properly handled and disposed of by the Contractor, and this must be done in accordance with all Massachusetts Department of Environmental Protection (DEP) Regulations, policies, and guidance. The responsibility for proper handling and disposal of this material shall be solely the Contractor's.

Material removed from the drainage structures shall be transported immediately to the place of disposal in machines or trucks that will not spill the material along the roadway. Any material falling onto the roadway shall be removed at the Contractor's own expense.

Catch basin cleanings are classified as solid waste by the DEP and may be disposed of at any landfill that is permitted by DEP to accept solid waste. Materials containing free-flowing liquids are prohibited from being accepted at landfills. The DEP encourages the beneficial reuse of this material whenever possible; however, use not in accordance with DEP determination, or disposal or use as fill in an unapproved location is not acceptable.

NOTE: It is anticipated that most, if not all, of the material will be landfilled, therefore the Contractor should be aware that many landfills may require testing and analysis of the material prior to accepting it for disposal at the facility. The Contractor should take this into consideration in preparing the bid.

SUBSECTION 187.80 METHOD OF MEASUREMENT

Material removed and that is to be transported to an approved facility, will be measured for payment in the hydraulic lift truck, after decanting.

SUBSECTION 187.81 BASIS OF PAYMENT

Excavated material will be paid for at the contract unit price per cubic yard for removal and disposal of drainage structure sediments, which price shall include the cost of removal, delivery and disposal at an approved landfill, disposal facility or recycling facility, the cost for approvals, permits, testing, transportation, and other incidental expenses.

SUBSECTION 187.82 PAYMENT ITEMS

ITEM 187.3 Removal and Disposal of Drainage Structure Sediments Cubic Yard

SECTION 201 BASINS, MANHOLES AND INLETS

SUBSECTION 201.40 GENERAL

Add the following at the end of this subsection:

Clay brick conforming to Section M4.05.2 of the Standard Specifications shall be used to adjust all manholes and catch basin frames and grates or covers to grade. For sewer manholes, Grade SS bricks shall be used for sewer inverts and shelves. Grade MS bricks shall be used for other locations.

Castings shall be as follows, or as directed by the Engineer:

1. Frames and Grates shall be Catalog #LF 245 as manufactured by E.L. LeBaron Foundry Co., 14 East Union St., Brockton, MA 02403, or approved equal.
2. Drain and sewer manhole frames and covers shall be Catalog #LK 110 as manufactured E.L. LeBaron Foundry Co., 14 East Union St., Brockton, MA 02403, or approved equal, with "DRAIN" or "SEWER" cast into cover as appropriate.
3. All Castings shall be Cast Iron minimum class 25, conforming to ASTM A48 (ASTM A48-76 for sewer), capable of withstanding AASHTO H-20 loading.

All exterior surfaces of manhole brickwork shall be plastered with cement mortar.

Leaching basins shall be precast concrete structures as approved by the Engineer.

SUBSECTION 201.60 GENERAL

Add the following at the end of this subsection:

Structures may be required to be built on (connected to) existing lines. Work may include, but is not limited to, excavation around existing pipe, removal/trimming existing pipe to inside face of structure, building new structure around existing pipes (including base and 4' sump), and backfilling/compacting around structure.

The limits of the excavation shall be sawcut or milled full depth through all existing pavement prior to any excavation for structure placement.

SUBSECTION 201.62 LAYING BRICKS AND BLOCKS

Add the following at the end of this subsection:

A minimum of 2 courses of brick shall be used to set frames on all manholes, catch basin and leaching basins.

SUBSECTION 201.63 PLACING CASTINGS

Add the following at the end of this subsection:

All three-flanged rectangular frames shall be placed as described above. The side of the casting without a flange shall be filled in with bricks and mortar or steel plates sufficient to cover any opening in the structure or as directed by the Engineer. Said work shall be considered incidental to Item 220, Drainage Structure Adjusted with no additional measurement or payment to be made.

Add the following new subsection:

SUBSECTION 201.66 LEACHING BASINS

Leaching basins shall be constructed with 4-foot sumps and shall be surrounded by 2 feet of crushed stone. Filter fabric shall line the entire excavation for the leaching basin up to the existing surface.

SUBSECTION 201.80 METHOD OF MEASUREMENT

Replace the first two paragraphs of this section with the following:

Measurement for catch basins, leaching basins, manholes and drop inlets shall be measured as complete units regardless of depth.

All cement blocks, filter fabric and stone associated with the construction of leaching basins shall be considered incidental to the cost of the leaching basin with no additional measurement or payment.

Sawcutting or milling of existing pavement to the excavation limits for structure placement shall be considered incidental to the cost of associated items, with no additional measurement or payment.

SUBSECTION 201.81 BASIS OF PAYMENT

Add the following at the end of this subsection:

All costs associated with construction of catch basins saddling existing drainage lines shall be included in the unit price per catch basin.

SECTION 230 CULVERTS, STORM DRAINS AND SEWER PIPES

SUBSECTION 230.60 CONSTRUCTION METHODS - GENERAL

Add the following at the end of this subsection:

For all pipes, including services, the limits of the trench shall be sawcut or milled full depth through all existing layers of pavement prior to any excavation for pipe placement.

Add the following new subsection:

SUBSECTION 230.65 UTILITY WARNING AND IDENTIFICATION TAPE

Buried Utility Warning and Identification Tape shall be placed at locations as directed by the Engineer. Said warning tape shall be made of plastic backed aluminum foil tape or detectable magnetic plastic tape with a minimum width of 3 inches. It shall be color coded and labeled continually along entire length of the tape in bold black letters for the appropriate utility and detectable by an electronic detection instrument. The markings on the tape should be permanent and unaffected by moisture or light.

Buried Utility Warning and Identification Tape shall be considered incidental to the work being done and no additional compensation will be offered for this item.

SUBSECTION 230.80 METHOD OF MEASUREMENT

Add the following at the end of this subsection:

The placement of pipe bedding shall be considered incidental to the placement of associated pipe, with no separate measurement or payment.

Sawcutting or milling of existing pavement to the excavation limits for pipe placement shall be considered incidental to the cost of associated items, with no additional measurement or payment.

SUBSECTION 230.81 BASIS OF PAYMENT

Revise 6th sentence to read as follows:

Backfill to replace material removed under Class B Trench Excavation for sewer or drain pipe shall be ¾" crushed stone for drainage as specified in Section 150.

SECTION 301 WATER SYSTEMS

SUBSECTION 301.60, PART F. REMOVAL OF CASTINGS

Insert the word "disposed," after the word "reset,"

Add this new subsection:

SUBSECTION 301.61 GAS GATES

It shall be the sole responsibility of the Contractor to coordinate with NationalGrid to have any and all gas gates adjusted to the proper grades or as directed by the Engineer. Unless otherwise directed by NationalGrid, it shall be the responsibility of NationalGrid to adjust said gates. In any case, however, no measurement or payment will be made for any gas gates adjusted by the Contractor.

SUBSECTION 301.80 METHOD OF MEASUREMENT

Add the following at the end of this subsection:

Measurement of water gate boxes adjusted shall include all risers as necessary, up to a length of 12 inches.

SUBSECTION 301.81 BASIS OF PAYMENT

Add the following at the end of this subsection:

All risers up to a length of 12 inches shall be considered incidental to the contract unit price for gate boxes adjusted, with no additional measurement or payment.

SECTION 402 DENSE GRADED CRUSHED STONE FOR SUB-BASE

SUBSECTION 402.20 GENERAL

Add the following:

Dense Graded Crushed Stone for Shoulders shall consist of crusher-run coarse aggregates of crushed stone or gravel and fine aggregates of natural sand or stone screenings uniformly pre-mixed and placed on the shoulders at locations directed by the Engineer.

SUBSECTION 402.61 SPREADING AND COMPACTING

Add the following at the end of this subsection:

The overall depth of the Gravel for Base Course layer shall be no less than 8 inches after compaction.

SUBSECTION 402.80 METHOD OF MEASUREMENT

Add the following at the end of this Subsection:

Dense Graded Crushed Stone for Shoulders shall be measured in place as directed by the Engineer, with no percentage added.

SUBSECTION 402.81 BASIS OF PAYMENT

Dense Graded Crushed Stone for Shoulders will be paid for at the contract unit price per cubic yard complete in place.

SUBSECTION 402.82 PAYMENT ITEMS

Add the following payment item in numerical order:

ITEM 402.12 Dense Graded Crushed Stone for Shoulders Cubic Yard

SECTION 403 RECLAIMED BASE COURSE AND/OR SUB-BASE

Replace the entire section with the following:

SUBSECTION 403.20 GENERAL

The work under this item shall conform to the relevant provisions of Section 403 of the Standard Specifications and the following:

The work shall include the pulverizing of the existing pavement, the blending of the pulverized material with the existing underlying base material, the spraying of liquid calcium chloride on the blended materials, the adding and the blending of additional granular material as needed to provide for a homogeneous base course meeting prescribed gradations, the grading and the compacting the blended material to the lines and grades as shown on the plans and as directed

by the Engineer, and the application of a final spray coat of liquid calcium chloride to the finished base course.

The work shall also include screening or other approved methods to remove oversized stones and the addition and mixing of additional granular material and bitumen into the blended material as necessary to bring the final reclaimed base course material into conformance with the specified gradation.

SUBSECTION 403.40 MATERIALS

All reclaimed material shall conform to the requirements of Subsection M1.11.0 of Division 111, Materials.

Aggregate for Crushed Stone for Blending, used to correct gradation deficiencies shall conform to the requirements of Subsections M2.0 1.0 to M2.01.6 of Division III, Materials.

Aggregate for Dense Graded Crushed Stone for Sub-base shall conform to the requirements of Subsection M2.01.7 of Division 111, Materials.

The blended base course shall be thoroughly mixed to a uniform gradation. If the blended material does not conform to the specified gradation, the Contractor shall furnish and mix additional granular material into the blended material to bring it into conformance, as directed by the Engineer.

Sampling and Testing

The Contractor shall be responsible for all sampling, testing, and analysis of materials associated with this item of work for the purposes of determining the material's existing and finished properties and characteristics as they may pertain to the specifications stated for this item of work. The Contractor shall employ a certified soils testing lab, subject to the approval of the Engineer, to perform the sampling, testing, and analysis. The Engineer shall specify the location of all test pits – at a minimum spacing of 500 feet. The results of the analysis shall be submitted to the Engineer for review and approval prior to the commencement of the dependent, respective activity of work. Any gradation deficiencies in the sampled materials, as indicated by the test results, shall be corrected by blending the appropriate aggregate size(s) into the mixture.

SUBSECTION 403.60 CONSTRUCTION METHODS

Reclaiming operations shall not be permitted when the existing pavement or sub-base contains frost, when the sub-base is excessively wet as determined by the Engineer, nor when the air or surface temperature is below 40° F.

Reclaiming operations shall not commence before April 15 and shall terminate on or before October 15 unless otherwise approved in writing by the Engineer.

Prior to the start of reclaiming operations, the Contractor shall locate and protect existing drainage and utility structures and underground pipes, culverts, conduits and other appurtenances.

The limit of each sequence of the reclamation process shall be 1.0 miles full width or as directed by the Engineer in order that the placing of pavement structure, up to the binder course, will be completed before beginning the next sequence of roadway reclamation work.

The Contractor shall be responsible for all testing and sampling of reclaimed materials associated with this work as specified hereafter. A certified soil-testing laboratory, approved by the Engineer shall do all testing of material samples.

Equipment

The recycling equipment shall have a positive depth control to insure a uniform depth of processing. This equipment shall have the ability to process the complete design depth specified into a homogeneous mass. It shall also be capable of crushing all oversize material encountered except ledge, or boulders larger than 8 inches in diameter.

A minimum of fourteen (14) calendar days prior to the proposed start of work, the Contractor shall submit in writing to the Engineer for approval, a description of the specific equipment and construction methods to be used in performing the work. The Contractor will be required to demonstrate, to the Engineer, the ability of the work crew and equipment to produce reclaimed material conforming to specifications at a rate of production consistent with the time allowed under the Contract. A test section shall be constructed approximately 500 feet long and one lane wide, and be located within the project limits at a location determined by the Engineer. The forward speed and processing direction (e.g., up cutting vs. down cutting) of the recycling equipment shall be recorded during construction of the test section. Representative samples of the reclaimed material shall be taken from this test section by the Contractor for analysis as directed by the Engineer. Full-scale production will not be allowed to commence until the Engineer has reviewed the test results and gives written approval of the equipment and construction methods used in the construction of the test strip.

Failure to meet gradation requirements or an insufficient production rate may be considered cause for rejection of the equipment, the construction methods, or both. The Contractor must then submit, in writing, the proposed changes in equipment and/or construction methods and either construct another test section or reconstruct the original section, as determined by the Engineer. This procedure may be repeated until acceptable results are obtained, at no additional compensation.

Otherwise, failure to meet gradation requirements due to improper equipment or construction methods shall not constitute a reason for any additional compensation for the import and blending of any aggregate to meet the deficiencies.

Approval of equipment includes the speed and processing direction it was operated at during construction of the test section. Therefore, the same operating speed and processing direction must be maintained during normal production. Changes in the equipment's operating speed and/or processing direction may only be made with the Engineer's written approval.

At least one vibratory roller shall be used on each reclaimed surface, and shall have a compacting width of not less than 5 feet. Each roller shall have a gross mass of not less than 16 tons.

Approved equipment shall be maintained in satisfactory working condition at all times.

Access to Area Abutters

Access to abutting properties shall be maintained at all times in accordance with the Standard Specifications, and Special Provisions located in the forward sections of this document.

Coordination

The proposed drainage and other subsurface utility improvements shall be constructed prior to the pavement reclamation work. The Contractor shall excavate all trenches in such a way as to maintain the roadway pavement and base material separate from the underlying soils. The roadway pavement and base materials shall be placed on the top of the trench during backfilling operations in preparation for the reclamation process.

If the Engineer determines that unsuitable material has been placed in the upper portion of the trench within the proposed reclamation depth, the Contractor shall remove this material and replace it with gravel borrow at no additional compensation.

Structure Lowering and Raising

All work shall be done in accordance with the applicable provisions of Section 220 and Section 301.

All drainage, utility, and municipality structures are to be referenced and lowered to a minimum depth 6 inches below the bottom of the proposed reclaimed base course. Lowered structures shall be covered with steel plates conforming to the requirements specified in Subsection 7.09. The voids remaining after the structures have been lowered are to be filled with a suitable material as determined by the Engineer. The Contractor will be responsible for the coordination with the respective utility companies for the lowering and raising of privately owned structures and gate boxes. The reclaiming operation shall not begin until all structures and boxes are lowered.

It shall be the Contractor's responsibility to maintain drainage functioning properly in the areas under construction up to the time when the final system is put into use. All structures lowered will be raised to the binder grade elevation upon placement of the binder course material for that section. Adjustment of the castings to final grade will not be allowed until the Engineer approves the placement of bituminous concrete top course material throughout the project.

Adjustment of Structures & Gates:

The work shall consist of rebuilding, removing, replacing, and adjusting the masonry and castings of present structures (manholes, catch basins, gate boxes, etc) as required, conforming to newly proposed line and grade changes, all in accordance with these specifications and in close

conformity with the lines and grades shown on the plans or established by the Engineer. Payment shall be per structure, lowered, plated, & raised inclusive.

Adjustments Greater than 6" Vertical

The price bid shall include the cost to lower and raise all structure castings. The structure shall be lowered to a depth of eighteen (18) inches or as sufficient to eliminate interference from the reclaimer. The structures shall be dismantled in a non destructive manner and covered with a steel plate.

Adjustments Less than 6" Vertical

When the line or grade or both the line and grade of the structure changes by six inches or less, the structure shall be adjusted to line and grade. The masonry shall be removed to such depth as directed by the Engineer and new masonry shall be constructed to conform to the proposed design.

The work under this contract shall comply in all respects to Section 220, "Adjustment, Rebuilding, & Remodeling of Drainage Structures" and Section 301, "Water Systems" of the Massachusetts Highway Department (MHD) "Standard Specifications for Highways and Bridges" 1995 Edition.

Reclaiming Operations

Prior to the start of reclamation, the existing pavement shall be swept with a power sweeper to remove all trash, sand, dirt, organic matter, and other undesirable material, to the satisfaction of the Engineer.

Also, the existing pavement shall be sawcut full depth within the areas where the adjacent surface is to be protected (curb, side streets, etc.) as shown on the plans and/or as directed by the Engineer.

The Contractor shall reclaim only that area of pavement that can be processed and compacted by the end of the same working day, at which time it must be opened to traffic, with the Engineer's approval. In any section, reclamation work shall be done on one-half the road width at a time. One-way traffic will be allowed only during working hours with traffic police present. Two-way traffic shall be maintained at all other times. Suitable ramping shall be in place at the beginning and end of work zone to allow for smooth and safe travel. This shall be considered incidental to the work for this item. The required density shall be maintained until the bituminous concrete pavement has been placed. Any imperfections discovered prior to its placement shall be repaired, as directed by the Engineer, at no additional compensation.

The total thickness of the pavement structure, unless otherwise indicated, and uppermost portion of the sub-base layer shall be recycled to the design depth specified on the typical section(s). The Contractor shall perform a sieve analysis of the reclaimed material for every 5,000 square yards of material processed or as often as conditions may require as determined by the Engineer. Test results shall be made available to the Engineer for review and approval. If conditions warrant, the Engineer may stop work until the required test results become available.

If the Engineer directs, due to gradation deficiencies in the existing materials as indicated by the test pits, the appropriate crushed stone aggregate size(s) shall be blended with the recycled material to produce a uniform mixture meeting the gradation requirements. Additionally, if the Engineer directs, dense graded crushed stone shall be added for volume purposes.

Any required modifications to the remaining sub-base such as, but not limited to, cuts, fills, and grade realignment shall be made. Existing unsuitable material shall be removed to the lines and grades established by the Engineer and replaced with a suitable material, as determined by the Engineer. Existing surplus reclaimed material shall be used, when available, at no additional compensation.

All unsuitable material and/or excess reclaimed material shall become the property of the Contractor to be properly disposed of outside the project limits.

Compaction and Dust Control

The reclaimed material shall be rolled, compacted and fine graded to the specified cross section(s) and/or grades as shown or as established by the Engineer.

The reclaimed base course shall be tested for compaction and smoothness and accuracy of grade in accordance with the applicable provisions of Subsection 401.60. The required density shall be measured by a Nuclear Density Gauge. If any portions are found to be unacceptable by the Engineer, such portions shall be reprocessed, re-graded, and re-compacted until the required smoothness and accuracy are obtained.

At the end of each day's progress, the Contractor shall apply Calcium Chloride in accordance with the applicable provisions of Section 440. Water for roadway dust control shall be applied as directed by the Engineer.

A grader, roller and water wagon shall be maintained on the project site during the reclamation process. The Contractor shall submit to the Engineer, in writing, a twenty-four (24) hour availability telephone number for any emergency maintenance dictated by the weather conditions or as determined by the Engineer, for repair, compaction, and dust control.

SUBSECTION 403.80 METHOD OF MEASUREMENT

Reclaimed base course shall be measured for payment by the square yard of pre-reclamation pavement area hence reclaimed, complete in-place within the lines shown on the plans, or as directed by Engineer. No deductions will be made for surface structures. The lowering and the plating of gates and structures will be considered incidental to this item and no additional compensation will be allowed.

Structures raised from the plated depth to the bituminous concrete binder course elevation or to the bituminous concrete top course elevation (in one operation) shall be measured as a remodeled unit each, complete and approved.

Structures adjusted from the bituminous concrete binder course elevation to the bituminous concrete top course elevation shall be measured as an adjusted unit each, complete and approved.

Structures rebuilt shall be measured by the average height in vertical feet and hundredths of a foot from the bottom of the deterioration to the plated depth. Structures damaged below the plated depth, due to the Contractor's negligence, shall be measured and deducted from the vertical foot measurement. Raising the structure from the plated depth will be measured as stated above for a remodeled unit.

SUBSECTION 403.81 BASIS OF PAYMENT

The accepted quantity of reclamation as measured above shall be paid for at the contract unit price bid per square yard. This unit price shall include all compensation for crushing, pulverizing, blending, spreading, grading, sawcutting the existing bituminous concrete at the direction of the Engineer, compacting, test section construction, blending with aggregate, moving the processed material to allow for modifications to the remaining sub-base and/or subgrade, moving reclaimed material from one location to another within the project and any incurred costs resulting from the Contractor's decision to process off site.

The unit price bid shall also include compensation for all costs associated with the removal of the castings and the referencing, lowering, and plating of the structures. It shall also include full compensation for all labor, tools, equipment, materials, and all incidental work necessary to complete the work as specified.

The accepted quantity of reclamation as measured above shall be paid for at the contract unit price bid per square yard. This unit price shall include all compensation for crushing, pulverizing, blending, spreading, grading, sawcutting the existing bituminous concrete at the direction of the Engineer, compacting, test section construction, blending with aggregate, moving the processed material to allow for modifications to the remaining sub-base and/or subgrade, moving reclaimed material from one location to another within the project and any incurred costs resulting from the Contractor's decision to process off site.

The unit price bid shall also include compensation for all costs associated with the removal of the castings and the referencing, lowering, and plating of the structures. It shall also include full compensation for all labor, tools, equipment, materials, and all incidental work necessary to complete the work as specified.

Removal and disposal of unsuitable material, surplus reclaimed material, or any sub-base/subgrade material necessary for grade changes shall be paid for at the contract price per cubic yard for Item 120 Earth Excavation.

Grading and compacting the manufactured stabilized base course and the sub-base and/or subgrade resulting from the removal of unsuitable material shall be paid for at the contract unit price per square yard for Item 170, Fine Grading and Compacting - Subgrade Areas.

Adjustment of drainage structures shall be paid for at the contract unit price each for Items 220.1.1, Drainage Structures Adjusted greater than 6" vertical and 220.1.2, Drainage Structures Adjusted less than 6" vertical.

Rebuilding of drainage structures shall be paid for at the contract unit price per vertical foot for Item 220.2, Drainage Structure Rebuilt.

Raising of lowered drainage structures shall be paid for at the contract unit price each for Item 220.5, Drainage Structure Remodeled.

Adjustment of sanitary structures shall be paid for at the contract unit price each for Items 220.7.1, Sanitary Structures Adjusted greater than 6" vertical and 220.7.2, Sanitary Structures Adjusted less than 6" vertical.

Raising of lowered sanitary structures shall be paid for at the contract unit price each for Item 220.8, Sanitary Structure Remodeled.

Aggregate for providing added volume shall be paid for at the contract unit price per cubic yard for Item 402, Dense Graded Crushed Stone for Sub-base.

Aggregate to correct gradation deficiencies shall be paid for at the contract unit price per ton for Item 403.1, Crushed Stone for Blending.

Calcium Chloride for dust control shall be paid for at the contract unit price per pound for Item 440, Calcium Chloride for Roadway Dust Control.

Water for dust control shall be paid for at the contract unit price per 1000 gallons for Item 443, Water for Roadway Dust Control.

SUBSECTION 403.82 PAYMENT ITEMS

ITEM 403.	Reclaimed Base Course and/or Sub-Base	Square Yard
ITEM 403.1	Crushed Stone for Blending	Ton

Insert the following new section in numerical order:

SECTION 442 LIQUID CALCIUM CHORIDE FOR BLENDING

SUBSECTION 442.20 GENERAL

Liquid Calcium Chloride shall be used for blending into reclaimed base material as directed by the Engineer.

SUBSECTION 442.40 MATERIALS

The calcium chloride solution shall be provided by the manufacturer as a true solution and shall not be reconstituted from flake calcium chloride. The calcium chloride shall meet the following material specifications (see ASTM Designation D98; AASHTO-M144).

Calcium Chloride	35% ± 1%
Alkali Chloride as NaCl	2% max.
Magnesium as MgCl	0.1%
Typical (in lbs. per gallon)	
Calcium Chloride	5.05
Sodium Chloride	0.2
Magnesium Chloride	0.004
Calcium Sulfate	0.004
Water	<u>6.002</u>
	11.26

SUBSECTION 442.60 CONSTRUCTION METHODS

The distributor for calcium shall be capable of applying liquid calcium chloride in accurately measured quantities at any rate between 0.1 to 2.0 gallons per square yard of roadway surface, at any length of spray bars up to 20 feet. The distributor shall be capable of maintaining a uniform rate of distribution of material regardless of change in grade, width or direction of the road. The distributor shall be equipped with a Digital Volumetric Accumulator capable of measuring gallons applied and distance traveled. The volume and measuring device shall be equipped with a power unit for the pump so that application is by pressure, not gravity. The spray nozzles and pressure system shall provide a sufficient and uniform fan-shaped spray of material throughout the entire length of the spray bar at all times while operating and shall be adjustable laterally and horizontally. The spray shall completely cover the roadway surface receiving the treatment.

After the first pulverization of the existing road pavement, one application of calcium chloride totaling 0.75 gallon per square yard shall be applied to the reclaimed material. The aggregate mass shall then be pulverized again to ensure proper asphalt, gravel and calcium chloride blending to the desired depth. Following base compaction, shaping, regrading and final compaction a final capping of 0.25 gallons per square yard of calcium chloride shall be applied.

SUBSECTION 442.80 METHOD OF MEASUREMENT

Liquid Calcium Chloride for Blending shall be measured by the gallon used.

SUBSECTION 442.81 BASIS OF PAYMENT

Payment for Liquid Calcium Chloride for Blending shall be paid for at the contract unit price per gallon used. Payment will be for the actual quantity applied that is not to exceed the quantity as calculated based on the aforementioned application rates and surface applications area as shown on the plans or as determined by the Engineer.

SUBSECTION 442.82 PAYMENT ITEMS

ITEM 442. Liquid Calcium Chloride for Blending Gallon

SECTION 460 HOT MIX ASPHALT PAVING

SUBSECTION 460.62 TACK COAT

Add the following at the end of this subsection:

Tack coat and sand shall be applied to all joints composed of hot mix asphalt immediately after paving or as directed by the Engineer.

SUBSECTION 460.63 SPREADING AND FINISHING

Add the following at the end of this subsection:

It should be noted that roads could require several lifts of leveling material in order to eliminate water problems in low spots prior to placing the top course of hot mix asphalt.

SUBSECTION 460.65 JOINTS

Insert the following after the 5th paragraph of this subsection

Paper joints shall be used when the road is not completed in its entirety. The joint shall be underlain with tarpaper and hot mix asphalt shall be placed on top next to the existing pavement. No joints shall be left at intersections of roadways. Special care should be taken to leave any joints no less than twenty feet away from all radius points at intersections or as directed by the Engineer.

SUBSECTION 460.80 METHOD OF MEASUREMENT

Add the following at the end of this subsection:

Tack coat and sand, when applied to joints in accordance with subsection 460.62, shall be considered incidental to Item 460, Hot Mix Asphalt, with no additional measurement or payment to be made.

SECTION 472 HOT MIX ASPHALT FOR MISCELLANEOUS WORK

SUBSECTION 472.60 CONSTRUCTION METHODS

Add the following at the end of this subsection:

Patching

Patching is used to remove isolated failed areas of pavement & sub-base. Patching shall consist of neatly & squarely cutting existing pavement, removal & disposal of existing base to a depth of 12", installation of 12" of compacted gravel, paving with 2 1/2" binder & 1/12" top, and sand sealing joints.

A paving machine shall be used in areas greater than six (6') wide.

Bituminous Concrete for Patching: All materials for bituminous concrete for patching as listed in Section 472 of the Standard Specifications shall conform to the requirements of Division III thereof, as applicable.

The mixture for pavement patching material shall conform to the requirements for "Patching Mix" in Table A of the job Mix Formula specified in Subsection M3.11.03 of Division III of the Standard Specifications.

Gravel Borrow: Gravel borrow for construction of gravel base shall conform to the requirements of Subsection M1.03.0 Type B of the Standard Specifications.

Grind and Inlay

The work to be done consists of excavating Bituminous Pavement by cold planer in designated areas to improve paved trenches and areas of disintegrating top coat, then replacing said areas with 1 1/2 inch of new bituminous.

The cold planer shall be capable of planning both the bituminous pavements and cement concrete patches if the latter should be encountered in bituminous pavements. The cold planer shall be equipped with all necessary safety devices such as flashing lights and backup signal so as to operate in traffic with complete safety.

Contractor shall furnish auxiliary milling equipment for clean-up work along curbs and around casting. Work area will be left clean and free from debris at the end of each day. Prices quoted shall include milling, loading, trucking, sweeping, and final clean-up. The use of planning equipment mounted on pneumatic tires will be permitted only for clean-up work.

Milled material will become the property of the contractor and will be disposed of off site. Depth of Planning cut will average 1-1/2 to 2 inches. Contractor will be responsible for damage to existing castings resulting from his operation unless such castings (water gates e.g.) have previously been paved over and are therefore not visible on surface.

A paving machine shall be used in areas greater than six (6') wide.

Bituminous Concrete for Inlay: All bituminous concrete materials used for Grind and Inlay shall be the same as for patching, as listed in Section 472 of the Standard Specifications and shall conform to the requirements of Division III thereof, as applicable.

The mixture for pavement patching material used for Grind and Inlay, shall conform to the requirements for "Patching Mix" in Table A of the job Mix Formula specified in Subsection M3.11.03 of Division III of the Standard Specifications.

SUBSECTION 472.80 METHOD OF MEASUREMENT

Add the following at the end of this subsection:

All punch list items such as driveway aprons, berm pads, etc, must be completed two weeks after wearing course has been placed.

Sawcutting, jacking or milling of existing pavement to the excavation limits for patching shall be considered incidental to the cost of Item 472, Hot Mix Asphalt for Miscellaneous Work with no additional measurement or payment.

SUBSECTION 472.82 PAYMENT ITEMS

Add the following at the end of this subsection:

Item 472.1	Patching	Square Yard
Item 472.4	Grind and Inlay	Square Yard

Insert the following new section in numerical order:

SECTION 482 CRACK SEALING OF BITUMINOUS CONCRETE SURFACES

SUBSECTION 482.20 DESCRIPTION - GENERAL

The work covered by this section consists of furnishing all plant, labor, equipment and materials necessary to perform all operations in connection with the cleaning and sealing of construction and random cracks in bituminous concrete pavements, including vegetation removal and sterilization of cracks where necessary.

SUBSECTION 482.40 MATERIALS - GENERAL

Crack Sealer shall be an asphalt-fiber compound designed specifically for improving strength and performance of the parent asphalt sealant.

- (a) Asphalt Sealant shall be AC-10 or AC-20 with a penetration of 75-100.
- (b) Fiber reinforcing materials shall be short-length polyester fibers having the following properties:

Length	7 mm	0.28 inch
Diameter	0.02032 mm +/- 0.0025 mm	0.0008inch +/- 0.0001 inch
Specific Gravity	1.32 to 1.40	
Melt temperature	250 degrees C. minimum	480 degrees F. minimum
Ignition temperature	538 degrees C. minimum	1000 Degrees F. minimum
Tensile strength	517,107 kPa +/- 35,000 kPa	75,000 PSI +/- 5,000 PSI
Break elongation	33% +/- 9% - they are fully drawn	

- (c) Black Beauty Boiler Slag (type used for sandblasting) shall be used for cover. Application shall be sufficient to prevent pickup of the completed application by traffic.

Asphalt fiber compound shall be mixed at a rate of 5-8% fiber weight of asphalt cement. This compound having the same chemical base provides compatibility and exhibits excellent bond strengths. The fiber functions to redistribute high stress and strain concentrations that are imposed on the sealant by thermal sources, traffic loading, etc.

CERTIFICATE OF MATERIAL COMPLIANCE

Manufacturer's certificate of material compliance shall be furnished to the Town certifying conformance to the above material specifications.

SUBSECTION 482.60 CONSTRUCTION METHODS - GENERAL

EQUIPMENT

Equipment used in the performance of the work required shall be subject to the approval of the Engineer and maintained in a satisfactory working condition at all times. The equipment shall include the following:

- (a) Air Compressor: shall be portable and capable of furnishing not less than 100 cubic feet of air per minute at not less than 90 lbs. per square inch pressure at the nozzle. The compressor shall be equipped with traps that will maintain the compressed air free of oil and water. If the velocity of this unit is not sufficient to thoroughly clean the crack/joint, as determined by the Engineer, a Hot-Air-Lance must be used.
- (b) Hot-Air-Lance: shall operate at 2000 degrees F. at 2000 feet per second velocity.
- (c) Manually operated, gas powered air broom or self-propelled sweeper: designed especially for use in cleaning highway and airfield pavements shall be used to remove debris, dirt, and dust from the cracks.
- (d) Hand tools: shall consist of broom, shovels, metal bars with chisel shaped ends, and any other tools which may be satisfactorily used to accomplish the work.
- (e) Melting Kettle: The unit used to melt the joint sealing compound shall be double boiler, indirect fired type. The space between the inner and outer shells shall be filled with a suitable heat transfer oil or substitute having a flash point of not less than 600 degrees F. The kettle shall be equipped with a satisfactory means of agitating the joint mechanically operated paddles and/or by a continuous circulating gear pump attached to the heating unit. The kettle must be equipped with thermo-static control calibrated between 200 degrees F. and 550 degrees F.
- (f) Application Shoe: shall be used according to sealers manufacturer's specifications. The Contractor shall have a range of shoe widths that will be used as directed by the Engineer. Compensation for the necessary changes of shoe width shall be included in the unit price bid per gallon.
- (g) Power Roller: shall be used if deemed necessary by the Engineer, and shall be a minimum 7 ton rubber tired roller with sufficient water capacity to prevent adhesion of the joint sealing material to the roller.

PAVEMENT PREPARATION

- (a) Debris removal: All old material and other debris removed from the cracks shall be removed from pavement surface immediately by means of power sweepers or hand brooms or air brooms.
- (b) Vegetation: When cracks show evidence of vegetation, it shall be removed and sterilized by use of Propane Torch unit eliminating all vegetation, dirt, moisture, and seeds.
- (c) General: No crack sealing materials shall be applied to wet cracks or where frost, snow or ice is present, nor when ambient temperature is below 40 degrees F.

PREPARATION OF SEALER

Joint sealing material shall be heated and applied at a temperature specified by the manufacturer and approved by the Engineer.

WORKMANSHIP

All workmanship shall be of the highest quality, and excess or spilled sealer shall be removed from the pavement by approved methods and discarded. Any workmanship determined to be below the high standards of the particular craft involved will not be accepted, and will be corrected and/or replaced by the Contractor as required by the Engineer. Any failure due to pickup by traffic within 7 days shall be redone without additional measurement or payment.

PERFORMANCE

The Contractor MUST be able to certify that it has the ability and experience to perform the subject work and that it has sufficient capital and equipment to enable it to prosecute the work successfully and to complete it within the time named in the Contract. The Town reserves the right to reject any or all bids, or to award the contract, as deemed to be in the best interest of the Town.

SUBSECTION 482.80 METHOD OF MEASUREMENT

Measurement for this Contract shall be by the GALLON and shall be the actual number of GALLONS of sealer applied to the pavement. The Contractor and Engineer shall agree on specific methods for tracking quantities actually used on the project prior to the application of any product. No payment shall be made for excess product remaining in the kettle at the end of the day. The Contractor and Engineer shall agree upon the actual quantity used at the end of each shift, and shall document daily used quantity on duplicate forms, signed by both parties.

SUBSECTION 482.81 BASIS OF PAYMENT

Payment shall be at the Contract unit price bid per GALLON of sealant applied to the pavement. Payment shall include the cost of all materials, labor, tools and equipment, and incidental work necessary to complete the work of this project.

SUBSECTION 482.82 PAYMENT ITEMS

ITEM 482.15 Hot Applied Asphaltic Crack Filler (Polyester Fiber) Gallon

Insert the following new section in numerical order:

SECTION 483 SAWING PAVEMENT AND SIDEWALK JOINTS

SUBSECTION 483.20 GENERAL

The work under this item shall conform to the relevant provisions of Section 120 of the Standard Specifications and the following:

The work shall include the sawcutting of existing hot mix asphalt and cement concrete pavements and sidewalks where shown on the plans, and as directed by the Engineer.

All edges of excavations made in existing pavements and sidewalks shall be squared by sawcutting with power driven tools to provide a neat, clean edge for joining new pavement or sidewalks. Sawcut equipment shall be approved by the Engineer prior to commencing work.

The existing pavement shall be sawcut through its full depth, to provide a uniform, vertical surface for the proposed pavement joint with the existing pavement. In areas where an existing sidewalk abuts a building, wall or storefront and is to be reconstructed, the existing sidewalk shall be sawcut a minimum of 6" from the building wall or storefront unless otherwise directed by the Engineer.

Sawcut edges which become broken, ragged or undermined as a result of the Contractor's operations shall be re-sawcut prior to the placement of abutting proposed pavement at no additional cost to the Owner.

Sawcut surfaces shall be treated as specified in accordance with Subsection 460.65 of the Standard Specifications or as directed by the Engineer.

SUBSECTION 483.81 BASIS OF PAYMENT

Sawcuts shall be made in the existing pavement in areas of drainage structure work, curb resetting and as directed by the Engineer. Payment for this work shall be included in the unit price under the applicable items that require sawcutting.

Sawing pavements and sidewalks will be paid for at the contract unit price per linear foot, which price shall include all labor, materials, equipment, and incidental costs required to complete the work.

SUBSECTION 483.82 PAYMENT ITEMS

Item 483.5 Sawing Pavement and Sidewalk Joints Linear Foot

SECTION 701 SIDEWALKS, WHEELCHAIR RAMPS AND DRIVEWAYS

SUBSECTION 701.20 GENERAL

Add the following at the end of this subsection:

Contractors shall establish grade elevations at all wheelchair ramp locations, and shall set transition lengths according to the appropriate table in the Construction Standards. All wheelchair ramp joints and transition sections that define grade changes shall be formed, staked, and checked prior to placing cement concrete. All grade changes are to be made at joints.

The Contractor is responsible for constructing all relative work to strict adherence with the requirements of MassDOT, and the Massachusetts Architectural Access Board. Detectable Warning Panels shall be installed on all wheelchair ramps as shown in the Construction Standards.

SUBSECTION 701.60 GENERAL

Add the following at the end of this subsection:

Existing Sidewalks shall be Excavated and Disposed of to make room for new sidewalks as directed by the Superintendent of Public Works. Existing Sidewalks shall be Excavated to a depth to suitable material. The amount of Sidewalk excavation is to be determined in the field. The Contractor is responsible to dispose of the excess material.

SUBSECTION 701.63 BITUMINOUS CONCRETE DRIVEWAYS

Add the following at the end of this subsection:

Existing Sidewalks shall be Excavated and Disposed of to make room for new sidewalks as directed by the Superintendent of Public Works. Existing Sidewalks shall be excavated to a depth to suitable material. The amount of Sidewalk excavation is to be determined in the field. The Contractor is responsible to dispose of the excess material.

Handwork - Work will include constructing driveway aprons, driveway sections, sidewalk sections, and other areas as directed by the Engineer. No additional compensation will be made for cutting existing pavement in order to provide a clean match line.

SUBSECTION 701.64 BRICK WALKWAYS

Add the following new subsection:

Remove and reset brick walkways per Town of Arlington Specifications and Details (included in Appendix A and ATTACHMENT # 2 - Arlington Brick Walkway Specifications and Details)

SUBSECTION 701.82 PAYMENT ITEMS

- Item 701.01 Color Additive for Cement Concrete See also Appendix A
- Item 702.1 Excavation and Disposal of Existing Sidewalks Square Yard
- Item 706.1 Remove and Reset Brick Walkway per Arlington Specifications and Details
- Item 706.1.2 Install New Brick Walkway per Arlington Specifications and Details

SUBSECTION 701.80 MTHOD OF MEASUREMENT

Add the following at the end of this subsection:

Handwork will be measured by the ton.

SUBSECTION 701.81 BASIS OF PAYMENT

Add the following at the end of this subsection:

Payment for Detectable Warning Panels shall be considered incidental to the construction of the wheelchair ramps or sidewalks in which they are being installed.

Payment for handwork will be paid for at the contract price per ton under Item 703, Bituminous Concrete Driveway [Handwork].

SECTION 850 TRAFFIC CONTROLS FOR CONSTRUCTION AND MAINTENANCE OPERATIONS

SUBSECTION 850.21 SAFETY CONTROLS FOR CONSTRUCTION OPERATIONS

Add the following at the end of this subsection:

Payment for safety controls for construction operations shall be considered incidental to the contract and the costs included in the unit bid price for those items requiring such controls. Item 851 is not included in this contract.

SUBSECTION 850.22 SAFETY SIGNING FOR CONSTRUCTION OPERATIONS

Add the following at the end of this subsection:

Safety Signage for Construction Operations shall be considered incidental to the work and may also include, but is not limited to, the following signs, mounted temporarily on their own posts or stands, as directed by the Engineer, as required for detour work:

DESIGNATION	SIZE	SIGN WORDING
M4-9L	30" x 24"	← DETOUR
M4-9R	30" x 24"	DETOUR →
M4-9U	30" x 24"	DETOUR ↑
M4-8A	24" x 18"	END DETOUR
R11-2	48" x 30"	ROAD CLOSED

R11-4	48" x 30"	ROAD CLOSED TO THRU TRAFFIC
N/A	48" x 36"	ROAD CONSTRUCTION BEGINS "Insert timeframe here" SEEK ALTERNATE ROUTES
W20-1	48" x 48"	ROAD WORK AHEAD
W8-8	30" x 30"	ROUGH ROAD
W8-3	30" x 30"	PAVEMENT ENDS
W8-1	30" x 30"	BUMP
G20-2A	36" x 18"	END ROAD WORK

The Contractor shall furnish, erect, remove, cover, relocate, and replace if necessary, all signs as directed by the Engineer. All signs shall be removed when no longer required.

Add this new subsection:

SUBSECTION 850.38 TRAFFIC POLICE DETAILS AND FIRE DETAILS

This work consists of scheduling Traffic Police Details when construction operations involve work which is of a nature where the use of a Traffic Police Detail would be required to increase safety of the general public and construction personnel.

This work also consists of scheduling Fire Details when construction operations involve blasting work. A Fire Detail will be required at all times explosives are present on site.

Scheduling of Details is the responsibility of the Contractor.

The Contractor is responsible for canceling Details directly in the event of schedule changes where work no longer requires the use of Details, or cancellations of work for any reason, including weather. A minimum of one hour prior to scheduled time must be required to cancel Detail.

Contractors that cancel scheduled work to which police, flag people or public works personnel are assigned on an additional pay basis are subject to contract back charges.

Police and fire details will be paid for directly by the Town of Arlington.

SECTION 868 REFLECTORIZED WHITE / YELLOW LINE – EPOXY

See Appendix A

Insert the following new section in numerical order:

SECTION 874 SIGN REMOVED AND RESET

SUBSECTION 874.20 GENERAL

The work to be done under this item shall conform to the relevant provisions of Section 828 of the Standard Specifications and the following:

The Contractor shall carefully remove and reset at new locations all existing signs, attached hardware and sign support posts not included under other sign items as directed by the Engineer.

Signs, attachment hardware and sign support posts shall be satisfactorily stored and protected until reset in the proposed work.

Signs, attachment hardware and sign support posts lost, damaged or otherwise made unsuitable for reuse while being removed, transported, stored or reset shall be replaced with new materials at no additional cost to the Owner. New attachment hardware shall be furnished and installed as necessary to replace any missing or unusable existing hardware.

Existing sign posts not suitable for resetting shall be replaced at no additional cost to the Owner.

SUBSECTION 874.80 METHOD OF MEASUREMENT

Signs removed and reset will be measured for payment as units, complete in place.

SUBSECTION 874.81 BASIS OF PAYMENT

Signs removed and reset will be paid for at the respective contract unit price per each, which price shall include all labor, materials, equipment, and incidental costs required to complete the work.

SUBSECTION 874.82 PAYMENT ITEMS

Item 874.1	Sign Removed and Reset	Each
------------	------------------------	------

END OF SPECIAL PROVISIONS

APPENDIX A

SECTION 120 EXCAVATION

SUB-SECTION 120.82 PAYMENT ITEMS

- ITEM 129.01 Asphalt Excavation by Cold Planer (9AM – 3PM)
Attention is called to this Item. Due to particular streets within the Town having heavy commuter traffic, the Arlington Police Department has restricted work hours to between 9 AM and 3PM. No work, including mark out, sweeping, trimming, etc is permitted before 9AM and after 3PM. This is necessary to ensure the safety of the motoring public, as well as the Contractors employees.
- ITEM 129.02 Asphalt Excavation by Cold Planer (4” Depth)
Attention is called to this Item. Due to the condition of the asphalt surface and base course on particular streets, it is necessary to remove all the existing asphalt material down to the gravel base. This ensures a consistent surface on which the new binder course can be installed. Due to this additional depth of excavation, the Contractor will be responsible for “ramping” driveways, intersecting streets, and beginning and end of project with suitable material.

SECTION 701 SIDEWALKS, WHEELCHAIR RAMPS, AND DRIVEWAYS

SUB-SECTION 701.82 PAYMENT ITEMS

- ITEM 701.01 Color Additive for Cement Concrete – Gray
Attention is called to this Item. There may locations within Town where it is desirable to darken new concrete sidewalks by the addition of Dry Powder Iron Oxide Pigment or Liquid Iron Oxide Pigment at the plant or onsite. Please see ATTACHMENT #1 for additional specifications. This Item will be an ADDITION to the Concrete Sidewalk, Driveway, and Wheelchair Ramp Items.
- ITEM 706.1 Remove and Reset Brick Walkway per Arlington Specifications
Attention is called to this Item. There may be locations in Town where it is desirable to carefully remove existing brick walkways, and reset existing brick on new 4” concrete base. Please see ATTACHMENT #2A & 2B for additional specifications and details. This Item shall INCLUDE the new 4” concrete base.
- ITEM 706.1.2 Install New Brick Walkway per Arlington Specifications
Attention is called to this Item. There may be locations in Town where it is desirable to install new brick sidewalks on new 4” concrete base. Please see ATTACHMENT # 2A & # 2B for additional specifications and details. This Item shall INCLUDE the new 4” concrete base and brick. New brick shall be wire cut and ADA compliant. Contractor shall submit samples for acceptance. “Boston Pavers” or approved equal

SECTION 868 REFLECTORIZED WHITE / YELLOW LINE - EPOXY

ITEM 868.04 ReflectORIZED White Line - 4" EPOXY

Attention is called to this Item. Please see ATTACHMENT #3 for additional specifications

ITEM 868.12 ReflectORIZED White Line - 12" EPOXY

Attention is called to this Item. Please see ATTACHMENT #3 for additional specifications

ITEM 869.04 ReflectORIZED Yellow line - 4" EPOXY

Attention is called to this Item. Please see ATTACHMENT #3 for additional specifications.

ATTACHMENT # 1

Color Additive for Cement Concrete – Gray

Submittals

Product Data:

Provide data on colored concrete product, expansion joint materials and cleaning solution, demonstrating compliance with Manufacturer's Specifications and recommendations. Provide manufacturer's standard color chart for selection of colored concrete and expansion joint sealer color.

Submit manufacturer's certification that materials comply with specified requirements and are suitable for the intended application.

Submit manufacturer's standard warranty.

Submit representative samples to Owner's Representative for selection approval. Do not order samples until approval is obtained

Quality Assurance

Perform work in accordance with ACI 301 and ACI 316. Conform to ACI 305 during hot weather. Conform to ACI during cold weather.

Obtain each material from same source and maintain high degree of consistency in workmanship throughout project.

Manufacturer's Qualifications: Sufficient plant facilities to provide quality and quantity of materials as required without delaying progress of work. Minimum of 10 years experience in producing iron oxide pigments to be added to concrete.

Installer Qualifications: Concrete work shall be performed by firm with a minimum of 5 years experience with work of similar scope and quality.

Colored Concrete Mock-up: Provide a minimum 5 x 5 area of colored concrete sidewalk.

Demonstrate methods of obtaining consistent visual appearance. Including materials, workmanship, and curing method.

Obtain Owner's Representative acceptance of visual qualities of sample before proceeding with the final work.

Retain samples of cements, sands, aggregates and color additives used in Mock-up for consistency throughout project.

Delivery, Storage, and Handling

Deliver materials in manufacturer's original unopened containers, with labels clearly identifying product name, manufacturer, color name and number, weight, and mixing instructions.

Store materials in clean, dry area in accordance with manufacturer's instructions. Keep containers sealed until ready for use.

Handle materials in accordance with manufacturer's instructions. Protect materials during handling and mixing to prevent damage or contamination.

Project Conditions

Colored Concrete Environmental Requirements:

1. Schedule placement to minimize exposure to wind and hot sun before curing materials are applied.
2. Avoid placing concrete if rain, snow, or frost is forecast within 24 hours. Protect fresh concrete from moisture and freezing.

- Schedule delivery of concrete to provide consistent mix times from batching until discharge.

Products

Color Admixture

Dry powder iron oxide pigments or liquid iron oxide pigments to be added to concrete at the concrete plant or onsite. Computerized additions of liquid pigments at the plant is preferred for consistent color between batches.

Acceptable Manufacturers:

- Davis Colors, 3700 East Olympic Blvd., Los Angeles, CA
- L.M. Scofield Company, 4155 Scofield Rd., Douglasville, GA
- Solomon Colors, PO Box 8288, Springfield, Illinois
- or approved equal

Dry Powder Iron Oxide Pigments: Integral Colors for Ready Mixed Concrete.

- Color: Light Gray, as approved by Owner's Representative
- Compliance: ASTM C 979
- Material: Natural and synthetic, milled, blended iron oxide in dry powder form.
- Produce uniform and consistent color.
- Permanent, inert, stable to atmospheric conditions, sunfast, weather resistance, alkali resistant, water insoluble, lime proof, and nonbleeding.
- Free of deleterious fillers and extenders.
- Free of admixtures.
- Particle size: 95 to 99 percent minus 325 mesh

Liquid Iron Oxide Pigments:

- Color: Light Gray, as approved by Owner's Representative
- Compliance: ASTM C 979
- Material: Predispersed iron oxide pigments containing high pigment solids in aqueous base liquid.
- Produce uniform and consistent color.
- Permanent, inert, stable to atmospheric conditions, sunfast, weather resistant, alkali resistant, water insoluble, lime proof, and nonbleeding
- Free of deleterious fillers and extenders.
- Particle size: 95 to 99 percent minus 325 mesh
- Specific Gravity: 1.9 to 2.0

Packaging: If color additives are to be added to mix at site, furnish color additives in premeasured ready mix disintegrating bags to minimize job site waste

Ready Mixed Concrete: ASTM C 94

Portland Cement: ASTM C 150. Use same source, brand, type, and color throughout project

A 4" slump in concrete mix is recommended. If greater workability is required, redesign mix to use water-reducing or super plasticizing admixture instead of adding water. Variations in water-

cement ratio affect final appearance of concrete. A low water-cement ratio promotes richer, darker concrete colors.

Course and Fine Aggregates: ASTM C 33. Use same source and color throughout project. Select gray tones of aggregate similar to final gray product color, or as approved by Owner's Representative.

Admixtures: Designed for use with concrete pigments. Do not use calcium chloride or admixtures containing chlorides. Use same admixtures throughout project

Concrete Mix Design: As specified in Standard Specifications Section 476 and 700, except as specified in this section

1. Color Pigment Weight: Maximum 10 percent of cement weight
2. Water to Cement Ratio: Maximum 0.50
3. Use same concrete mix design throughout project

Curing Compound for Colored Concrete: Curing compound shall comply with ASTM C 309 and be approved by color additive manufacturer for use with colored concrete

Installation of Concrete

Follow all requirements for concrete work in Section 476 and 700 of the Standard Specifications

Do not apply color additives meant for integral coloring to surface of concrete

Apply broomed finish on all concrete

Apply curing compound for colored concrete in accordance with manufacturer's instructions. Apply curing compound at consistent time for each pour to maintain close color consistency

Color Additives: Mix in accordance with manufacturer's instructions. Mix until color additives are uniformly dispersed throughout mixture and disintegrating bags, if used, have disintegrated. Do not retemper mix by adding water in the field.

Application - Dry Powder and Liquid Iron Oxide Pigments

Measuring, Batching, Mixing, and Delivering Concrete: As specified in Section 476 and 700 of the Standard Specifications, except as specified in this section

1. Measure, batch, mix, and deliver concrete with pigments in accordance with manufacturer's instructions
2. Ensure mixer is clean and free of washout water before loading
3. Load mixer to a minimum of 40 percent capacity
4. Do not load mixer beyond recommended capacity
5. Add concrete materials to mixer in same order for each batch
6. Do not add pigment to mixer as first concrete material
7. Maintain consistent amounts of batch water in each batch

Placing, Finishing, and Curing Concrete: As specified in Section 476 and 700 of the Standard Specifications, except as specified in this section:

1. Place, finish, and cure concrete with pigments in accordance with manufacturer's instructions
2. Allow excess surface water to evaporate before finishing
3. Do not over finish surface. Avoid burning surface
4. Do not fog with water or cover surface of colored concrete during initial curing process for a minimum of 48 hours

Add liquid pigments to concrete batch automatically by use of metering, volumetric, or weight measuring system or manually by weight or volume in accordance with manufacturer's instructions

Recycle liquid pigments while in their container before use to ensure conformity and proper viscosity

Add liquid pigments to concrete batch after prewetted aggregate and before cement addition

Cleaning

Clean concrete of efflorescence in accordance with manufacturer's instructions

Ensure concrete has sufficiently cured before cleaning

Use concrete cleaner approved by pigment manufacturer and Project Engineer. Do not use cleaners containing acid.

Apply cleaner in accordance with manufacturer's instructions

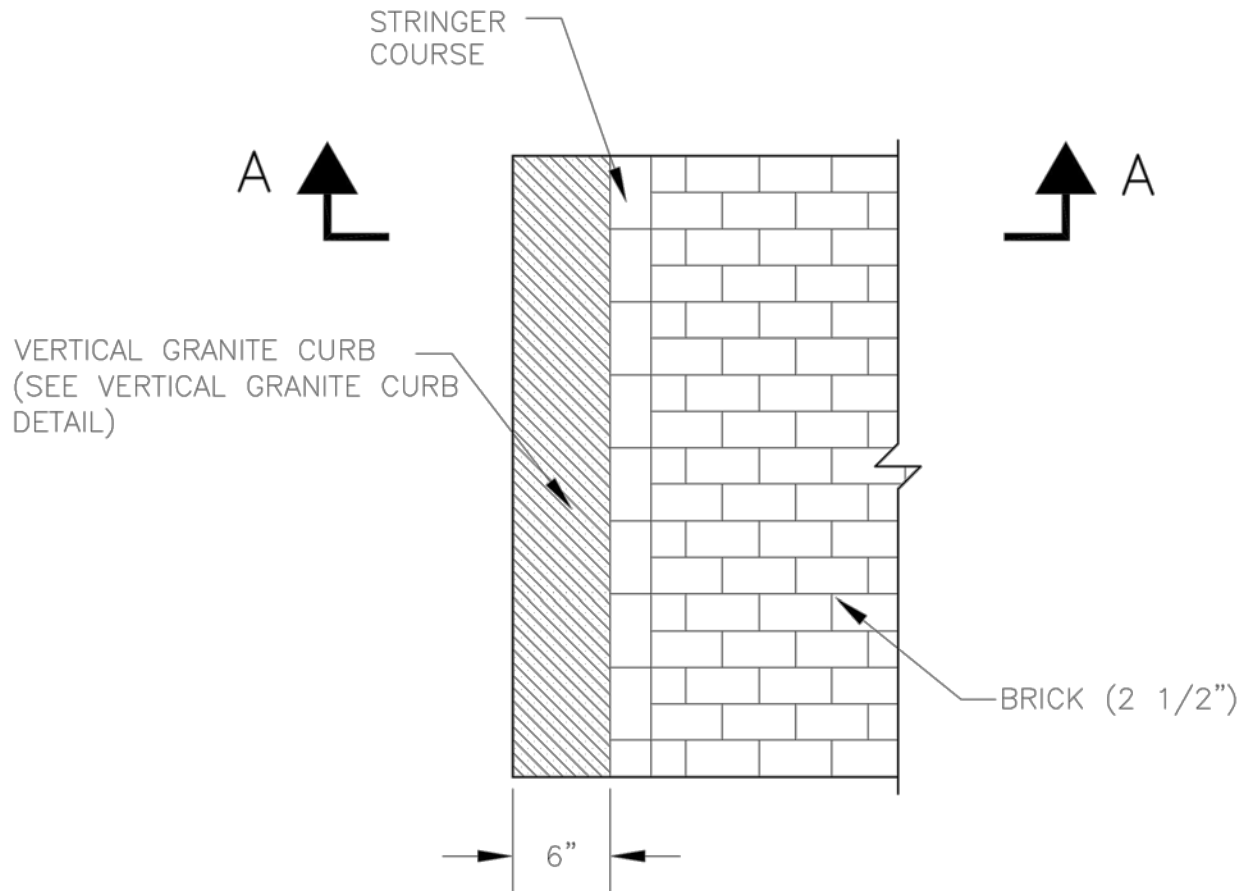

PLAN

ATTACHMENT 2A
BRICKSIDEWALK
(PLANVIEW)

JAN.2015

NOT TO SCALE

REVISION

①

R-0012



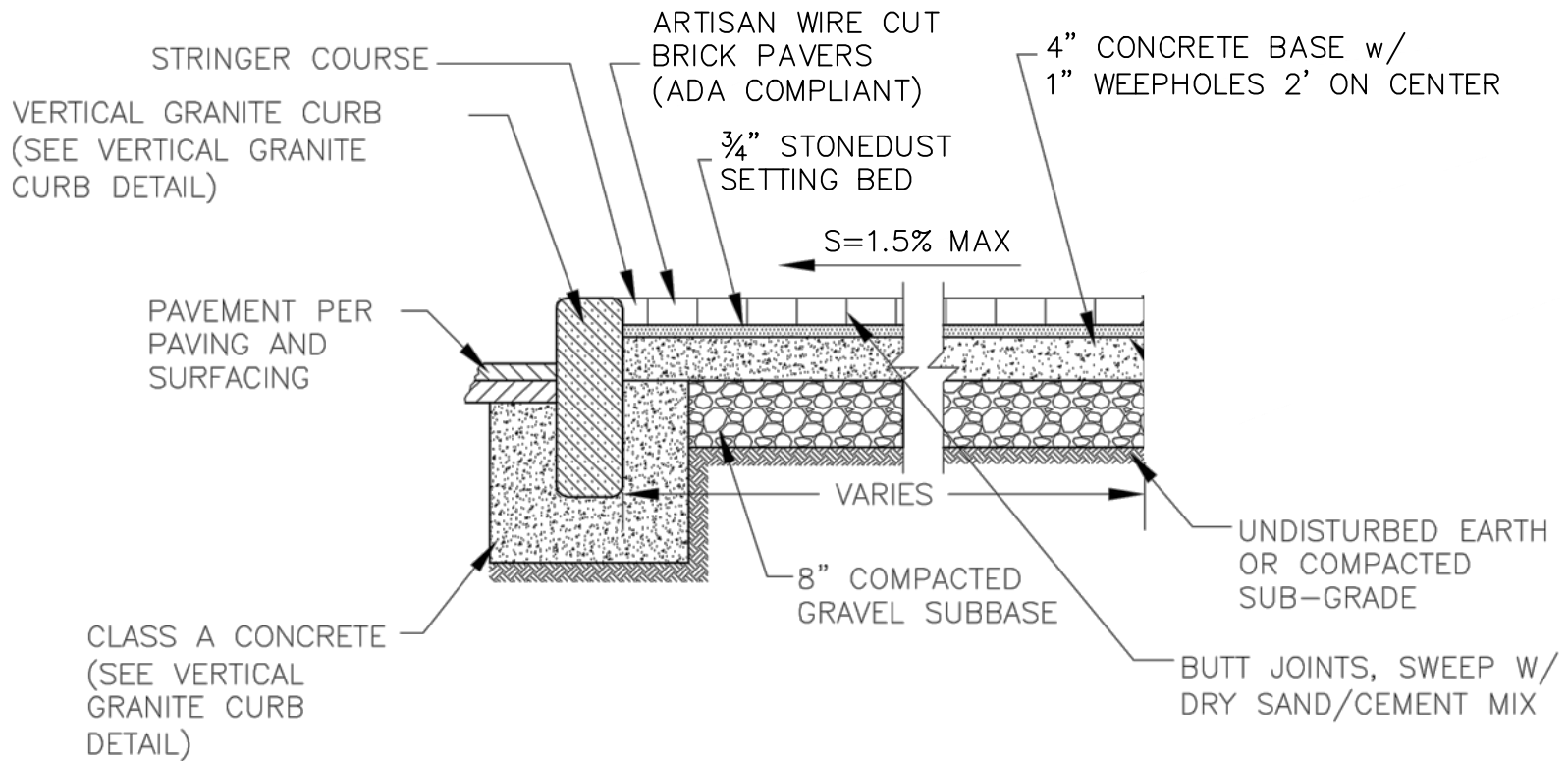

SECTION A-A

NOTES:

1. INSTALLATION OF BRICK TO BE COMPLETED IN ACCORDANCE WITH MANUFACTURER'S SPECIFICATIONS.
2. A SUBGRADE CONSISTING OF GRADED AGGREGATES MAY BE REQUIRED WHEN SUBGRADE CONDITIONS ARE POOR.
3. EXPANSION JOINTS SHOULD BE USED TO ACCOMMODATE ALLOWANCES FOR MOVEMENT IN MATERIALS. EXPANSION JOINT FILLER MATERIALS MUST BE HIGHLY COMPRESSIVE & DURABLE.
4. STONEDUST TO BE SWEEP INTO VOIDS, CRACKS, AND OPENINGS IF PRESENT IN COMPLETED SURFACE AND COMPACTED. THIS PROCESS SHALL BE REPEATED AS NECESSARY TO THE SATISFACTION OF THE ENGINEER.

ATTACHMENT #3

Reflectorized White Line – 4” EPOXY

Reflectorized White Line – 12” EPOXY

Reflectorized Yellow Line – 4” EPOXY

Scope

Work under these Items cover white and yellow epoxy reflectorized pavement striping material that is sprayed onto the pavement. Work under these Items shall conform to the relevant provisions of Section 860 of the Standard Specifications and the following:

Suggested Suppliers

Epoplex – Stonhard Inc, Maple Shade, NJ

Baltimore Paint and Chemical Co, Baltimore MD

Accent Stripe, Inc, Orchard Park, NY

Epoxy Material

The epoxy resin composition shall be specifically formulated for use as a pavement marking material and for hot spray application at elevated temperatures. The epoxy marking material shall be a two component, 100% solids type system formulated and designed to provide a simple volumetric mixing ratio. The epoxy marking material shall be supplied as either a regular dry or as a slow dry material. Regular dry may be used for all marking patterns. Slow dry material is intended for marking hatchlines, edgelines, and other marking patterns located out of the general path of traffic.

Reflective Glass Spheres

Reflective glass spheres for drop-on application shall conform to the following requirements. The glass spheres shall be colorless, clean, transparent, free from milkiness or excessive air bubbles, and essentially clean from surface scarring or scratching. They shall be spherical in shape and at least 80% of the glass beads shall be true spheres when tested in accordance with ASTM D1155, Procedure A

Striping Equipment

The equipment shall have a system capable of spraying the epoxy paint in the manufacturer’s recommended proportions and be mounted on a truck of sufficient size and stability, and with an adequate power source to produce lines of uniform dimension and prevent application failure. It shall be capable of placing stripes on the left and the right sides and of placing two lines simultaneously. It shall also be capable of applying glass beads at a rate of 25 lbs per gallon. All guns must be in full view of the operator at all times. The equipment shall be provided with a metering device to register the accumulated installed footage for each gun each day.

Each vehicle shall include at least one operator who shall be a technical expert in equipment operations and epoxy application techniques.

Equipment shall have such a design that the pressure gauges for each proportioning pump are constantly visible to the operator at all times during the operation so that any fluctuation and pressure difference can be addressed immediately.

Surface Preparation

The pavement surface on which the epoxy paint material is placed shall be clean and dry.

Application

Epoxy

The epoxy paint markings shall have a thickness of 25 mils +/- 1 mil, calculated without drop-on glass beads. All markings shall have uniform thickness with a uniform distribution of glass beads throughout the line width. The width of these lines shall be as specified with a tolerance of 0.25 inches. Markings shall have sharp edges and cutoff at the ends.

Glass Beads

The glass beads shall be applied by the double drop method, which requires that Type I and Type II reflective glass spheres be injected into or dropped onto the liquid epoxy marking. Each type shall be applied simultaneously, at a minimum rate of 10 to 13 pounds per gallon of resin with a minimum total application of 25 pounds per gallon. Type I beads shall be applied first, immediately followed by type II beads. The beads shall adhere to the cured epoxy or all marking operations shall cease until corrections are made.

Temperature Limitations

During marking operations, the pavement surface where the epoxy is to be placed shall have a minimum temperature of 40 degrees F and the ambient air temperature shall be at least 35 degrees F. The pavement surface temperature shall be determined at the start of each day of marking operation and at any time deemed necessary by the Engineer. The spraying temperatures shall be in accordance with the manufacturer's recommendations.

Application Rates

Application rates will be checked by the Engineer at convenient intervals by comparing tallies of materials used to lengths of lines placed.

Protecting Newly Installed Markings

Newly installed markings shall be protected from tracking during the setting period by the following method:

1. Cone off wet lines from traffic