

HMFH Architects, Inc.



**Space Planning Report
for Arlington Public Schools**

Arlington, MA

September, 2015

130 Bishop Allen Drive
Cambridge, MA 02139
617 492 2200



Table of Contents

Introduction

Enrollment Projections/ Forecasts

Process

Expansion Potential

Alternatives

Appendix

- A. Demographics Report
- B. Enrollment Forecasts Summary
- C. Capacity/ Space Use Chart
- D. Elementary Schools Floor Plans *
- E. Space Planning Schemes
- F. Gibbs Floor Plans *

*Base plans provided by School Department. Plans are available on the website but not in hard copy format.

Space Planning Report for Arlington Public Schools

Introduction

The Arlington Schools are experiencing an upward trend in student enrollments. This is likely due to many factors including a strong school system, a highly livable community, volume of housing sales/turnovers, new housing stock, and the proximity to the high tech/ bio-tech growth industries in Boston, Cambridge and surrounding communities. The enrollment growth is occurring at all grade levels and, therefore, already is or will be affecting the capacity of many of the school buildings.

HMFH Architects, Inc.'s role is to assess the conditions and recommend alternatives to accommodate the impact of enrollment growth. The space planning tasks include review of existing facilities space use, capacity, and availability for expansion; develop enrollment projections (completed by McKibben Demographic Research); and, working with the School Department, develop alternatives for how best to accommodate the increase of students.

Arlington operates seven (7) kindergarten through grade five elementary schools (Bishop, Brackett, Dallin, Hardy, Peirce, Stratton, and Thompson), one middle school, grades six, seven, and eight (Ottoson), and one high school, grades nine through twelve.

Enrollment Projections/ Forecasts

In an effort to provide a comparison to the enrollment projections developed annually by the Arlington School Department, McKibben Demographic Research was engaged to develop 10-year population and enrollment forecasts. As is stated in the McKibben Forecasts (for full report see **Appendix A**), there is a distinction between a projection and a forecast. A projection extrapolates the past (and present) numbers into the future with little or no attempt to take into account many factors that may impact the extrapolation. A forecast results when a projection is modified by reasoning to take into account external factors such as changes in fertility rates, housing patterns, and migration patterns.

In aggregate, both the Arlington Public School (APS) projections and the McKibben forecasts show a comparable increase in enrollments at all grade levels over the next ten years, with the McKibben forecasts slightly higher than the APS projections. What the McKibben forecasts show is the "wave" of enrollment growth currently at the elementary grades will continue through the middle and high school grades. The distinction between the projections and the forecasts is evident in that the forecasts show a downturn at the elementary level

after a peak in school year 2019-20. And though it is a downturn, by school year 2024-25 the elementary levels are still higher than they are today (by 149 students).

As mentioned, the “wave” of students will progress to Ottoson Middle School. The school was designed for 1,050 students when it was expanded in the mid-1980s, and it currently has a student population of over 1100. The middle school population is forecasted to increase by over 200 students within five years and another 150 students within the five years after that, thereby increasing the three middle grades to 1,468 students.

This same wave will take the high school student population from its current level of just over 1200 to 1,597 students by school year 2024-25. System-wide the enrollment is forecasted to have a 10-year increase of 1,039 students.

From the McKibben report: a primary factor causing the district’s enrollment to increase is the steady level of in-migration of young households/ families and an increase in the number of households over age 70 that are out-migrating. At the elementary level, Brackett, Hardy, and Thompson are forecasted to have the largest enrollment growth of 87, 113, and 110 students, respectively, by school year 2019-20 while the others remain relatively steady or, in the case of Stratton, are able to accommodate the increase of enrollment within their existing facility. It is worth noting that while the other neighborhoods are not currently showing an increase in enrollment (i.e. in-migration of young households) when reviewing the McKibben population pyramids for Bishop and Stratton one can see the wide band of 60-64 year olds that will (in ten years) be reaching the out-migration stage and therefore, the potential that these neighborhoods (and schools) will experience yet another wave of enrollment growth.

A summary of the forecasted enrollment growth, along with an Arlington map graphic is in **Appendix B**. It is worth noting that the potential development of the Mugar Property in East Arlington is not factored into the forecasts.

Process

Site Visits

Concurrent with the enrollment forecasting effort, the Space Planning process began with site visits to the school buildings and, when possible, conversations with the school principals. The visits enabled HMFH to review the physical interior spaces (in terms of size and location within the building) and to learn how each space is currently being used. The visits included a review of the school property, inclusive of outdoor amenities (play structures, play surfaces, parking, drop-off areas, green spaces), the topography, and adjacent streets and properties. In addition to visiting the nine active APS buildings, the former Gibbs/ East Middle School was also visited and assessed.

The Gibbs is a Town-owned school property that is currently occupied and leased by multiple, valued tenants that serve the citizens of Arlington. While it is universally felt that terminating these ten-

ant's leases would be disagreeable for all, with a student population increase of over 1,000 students in the coming years, it would be irresponsible not to assess all of the Town's resources as we plan for the future.

Available information was gathered including building floor plans, Google maps of the properties, and the Town's GIS building square footage and land acreage records.

Capacity Analysis

The elementary schools were reviewed in terms of their current capacity and space use and a chart of the findings is in **Appendix C**. Three schools, Brackett, Dallin, and Thompson, are identified as being "at capacity" as of the 2015/16 school year. The designation of "at capacity" was determined by several factors when in comparison to all of the elementary schools. In addition to kindergarten and general classroom spaces, each of the elementary schools has designated art and music classrooms. All but Brackett, Dallin, and Thompson have designated computer rooms. Of note, all schools have various specialist rooms, many of which are undersized to be considered to be used as classrooms. Most of the schools have dedicated Arlington After School Program (AASP) spaces in school year 2014/15, though some of these are located in kindergarten (in the case of Thompson) or general classrooms (in the case of Brackett). In **Appendix D** the elementary school floor plans show the general classrooms and kindergarten spaces as of school year 2014-15.

Of the three schools that are "at capacity", Dallin is not expected to experience growth; Brackett is expected to experience growth, but with thoughtful planning and the relocation of program spaces will be able to accommodate the increase in the near-term but will need additional space in the future; conversely the Thompson building is unable to accommodate the anticipated increase. The new Thompson School - designed for 380 students (per agreement with the MSBA) when it opened in September 2013 - in its second year had 392 students, and is anticipating an enrollment of 433 students in fall 2015, 463 by fall 2016, and 502 students by school year 2019-20.

And while Hardy School is not currently "at capacity", it is anticipated that it will be by school year 2017-18, and with its forecasted growth from 392 in school year 2014-15 to 505 in 2019-20 (a nearly 30% increase) it will require more classrooms.

Another method of understanding building capacity is to quantify the number of kindergarten and general classrooms available times the number of students per room; for these purposes a range of 22-25 per room is used. At Thompson there are 4 kindergarten and 15 general classrooms, therefore a range of 418-475 students can be accommodated. And at Hardy there are 4 kindergarten and 14 general classrooms, therefore a range of 396-450 students can be accommodated. Based on these calculations, even at the higher class sizes, Thompson and Hardy Schools will be beyond their capacity.

Ottoson Middle School is currently “at capacity”. When expansion to the facility occurred in the mid-1980s it was intended to serve 1,050 students. In the ensuing 30 years many educational changes have occurred that impact how teaching and learning occur, what subjects are taught, and the types of spaces needed. Special education requirements, technological advances, specialists, hands-on learning, and world languages (in addition to French, Spanish, and Latin, Mandarin is now taught) require adequate space to serve the engaged student population. Based on the current educational needs (and population of 1,107) the school is at capacity.

The forecasts show a steady increase of middle school enrollment over the next 10-year period. In five years, Ottoson is likely to have over 1300 students and within 10 years it is anticipated to reach nearly 1500 students. Based on these numbers, the middle school growth cannot be accommodated at Ottoson and corrective measures will need to be implemented.

Arlington High School’s (AHS) student population will also continue to rise. The steady forecasted increase will bring the enrollment from 1,217 in school year 2014-15 to 1,371 in school year 2019-20 and to nearly 1600 by 2024-25. This rate of growth will start to be impactful in just a few short years, resulting in larger class sizes, inhibiting the ability to offer programs, and overwhelming the shared use spaces such as the cafeteria, gymnasium, and school library. This Space Planning effort does not address the impact the rise in student population will have at AHS, because the Town anticipates admittance into the Massachusetts School Building Authority’s (MSBA) grant program for the high school within the next cycle or two and at that time an in-depth Feasibility Study will be undertaken to ascertain the most educationally sound, fiscally responsible approach to accommodate the enrollment and upgrade the facility.

The former Gibbs School was analyzed to identify its enrollment capacity to begin to understand the potential opportunities for future use by the school system. The school was designed as a middle school and used by the Town until 1989. The building is currently leased by Lesley Ellis School, Arlington Center for the Arts, Keliher Center, Learn to Grow, and Arlington Recreation Gymnasium. There have been minor alterations to the interior of the facility, but for the most part the “bones” of the original school building are intact. A rough layout of spaces seems to allow for 24 general classrooms, Gymnasium, Library, Cafetorium, and 6 or more specialist spaces. Using either 22-25 students per classroom there is a capacity of 528-600 students. The building would require some level of renovations (exact to be determined through a study process).

Expansion Potential

The schools were assessed for their ability to be expanded with additions, see findings in Appendix B. Many site conditions impact the expansion potential: what are the outdoor amenities and functions that occur around the perimeter of the building, whether the topography is level or sloping, and whether the portion of the building that is near the potential buildable/ available land is an appropriate attachment point for an addition.



The physical opportunities and constraints (not the programmatic impact), were assessed using a rating of Good, Fair, and Poor. Good allows that there is level land that has a low-level of use and is located on the site with a probable connection point to the school building. The determination of “low-level” of use means it is either unused or its current use may be relocated elsewhere or is redundant. The following schools are identified as Good: Bishop, Hardy, Stratton, and Thompson.

Brackett, Dallin, Ottoson, and AHS are rated Fair because in all instances connecting to the available land would require blocking either a fire lane loop or a secondary access point (in the case of Ottoson). Brackett’s interior connection point would require altering a teaching space or the school’s performance platform. At both Ottoson and AHS the available space is used for either parking or sports fields. While none of these concerns are insurmountable with Town approvals, they are not ideal and, therefore, are deemed only Fair for expansion.

Expansion opportunities at Peirce are poor. The open and available spaces are located a half floor level below the school’s lowest level, creating a poor connection point. In addition, much of the land around the property is sloping.

Alternatives

A series of schemes were developed to accommodate the expected increase in enrollments. Each scheme addressed the anticipated peak year within the 10-year timeframe of the enrollment forecasts. Most of the elementary schools will see their highest numbers in school year 2019-20. The middle school will be at its highest expected enrollment in school year 2023-24, while the high school’s highest enrollment is shown to be school year 2024-25, which is the tenth year in the 10-year projections. It is possible the numbers may increase in the years beyond the 10-year forecast.

Stratton Elementary School

Ahead of the anticipated enrollment growth, there is an immediate need to accommodate the Stratton School population during school year 2016-17 when the school will be renovated. The initial schemes included incorporation of this temporary need for the Stratton population at other school sites that would then use the classrooms to accommodate their growth needs, specifically at Hardy, Thompson, and Ottoson. It became apparent that the immediate requirement to solve the Stratton temporary needs was then driving many other decisions that would have a long-term educational and fiscal impact. The decision to separate the Stratton temporary needs from the longer term needs of the district would then allow time to fully vet the various scenarios with a larger audience over a longer period of time. Therefore, the School Committee made the decision to accommodate the Stratton population in temporary modular space located on the Stratton site for the school year during renovations.

Schemes

Schemes 1 and 1A propose additions either with modular construction (**1**) or with permanent construction (**1A**) to Hardy and Thompson Schools and renovations to Gibbs/East Middle School to accommodate the sixth grade by school year 2018-19.

Steps for Scheme 1:

- Modular classroom addition at Thompson school year 2016-17
- Modular classroom addition at Hardy school year 2017-18
- Relocate 2 SLC spaces from Brackett to Peirce school year 2017-18
- Temporary leased modular classrooms at Ottoson for school year 2017-18
- Renovate Gibbs School to accept 6th Grade in school year 2018-19
- High School planning schedule to be determined with MSBA

Steps for Scheme 1A:

- Temporary leased modular classrooms at Thompson school year 2016-17
- Addition at Thompson school year 2017-18
- Addition at Hardy school year 2017-18
- Relocate 2 SLC spaces from Brackett to Peirce school year 2017-18
- Lease modular classrooms at Ottoson for school year 2017-18
- Renovate Gibbs School to accept 6th Grade in school year 2018-19
- High School planning schedule to be determined with MSBA

Permanent construction at Hardy and Thompson would take one year longer than modular construction would, therefore in Scheme 1A Thompson would require two leased modular classrooms. Additionally, temporary, leased modular classrooms would be required at Ottoson to accommodate the increase of enrollment (forecasted to be an additional 125 students) in the intervening years.

In Scheme 1, there may be the possibility of shifting program spaces at Thompson to allow for a delay of installing the modular classrooms by one year, thereby installing them at the same time as those at Hardy. Installation of 12 modular classrooms as a single project may provide a small reduction in costs through the economies of scale.

Additionally, in an effort to eliminate the need to expand either Thompson or Hardy, Gibbs/East was assessed as to whether it could accommodate both the sixth grade and the Thompson and Hardy fifth graders. An addition of approximately 12 spaces (classrooms and specialists) and support facilities would be required at Gibbs/East. While it is likely that an addition of this size would be more costly than the two additions at the elementary schools, what is more problematic is to separate only a small cohort of fifth grade students from the elementary environment. Additionally the gym and cafeteria would not be expanded and cannot accommodate the nearly 700 students.

Schemes 1 and 1A will provide a unique opportunity for the 6th graders to coalesce as a class ahead of arriving to middle school. The shift in grade structure will require thoughtful review.



Scheme 2 proposes the fifth grade is located in a renovated Gibbs/East Middle School and the eighth grade is located at Arlington High School.

Steps:

- Temporary leased modular classrooms at Thompson school year 2016-17 and more in 2017-18
- Temporary leased modular classrooms at Hardy school year 2017-18
- Relocate 2 SLC spaces from Brackett to Peirce school year 2017-18
- Temporary modular classrooms at Ottoson for school year 2016-17 and more in 2018-19
- Renovate Gibbs School to accept 5th Grade in school year 2018-19
- Middle/High School planning schedule to be determined with MSBA

The construction required to accommodate the eighth grade would occur within the same timeframe as the High School study, design, and construction project should the town be invited into a feasibility study with MSBA within the next cycle or two of their process. In the intervening years there will be a need for leased modular classrooms at Hardy, Thompson, and Ottoson.

As noted in Scheme 1, there may be the possibility of shifting program spaces at Thompson, thereby requiring only two modular classrooms rather than four.

A result of implementing Scheme 2 is there would be an excess of unused space in most of the elementary schools.

Scheme 2A proposes shifting the 5th grade to Ottoson, the 7th grade to Gibbs/East, and the 8th grade to the High School site. The scheme is similar to Scheme 2 in terms of timeframe and costs. Both Schemes 2 and 2A will require thoughtful review of the proposed changes to the current grade structure model.

Scheme 3 proposes that all anticipated enrollment increases are accommodated with modular construction at Hardy, Thompson, and Ottoson.

Steps:

- Modular classroom addition at Thompson school year 2016-17
- Modular classroom addition at Hardy school year 2017-18
- Relocate 2 SLC spaces from Brackett to Peirce school year 2017-18
- Modular classroom addition at Ottoson for school year 2016-17, school year 2018-19 and school year 2021-22
- High School planning schedule to be determined with MSBA

Additions at Hardy and Thompson may be physically accomplished on the properties and would be strategically connected to the existing buildings. And while there will be an impact on the core shared use spaces (Gym, Cafeteria, and Library) and administrative services, it is believed with careful planning these spaces will be able to absorb the increase. Conversely, to accommodate the Ottoson enrollment growth at the Ottoson site would have a negative impact on both the shared

use spaces and support services. Ottoson's population is expected to increase by 40% above the original design intent of the school building. Adding modular classrooms to accommodate the growth is only half of the solution, the Gymnasium, Library, Cafeteria, Kitchen, Guidance, Health Services, and many other specialists would also need to "grow" to serve a student population of nearly 1500.

Scheme 4 proposes renovating and expanding Gibbs/East to accommodate both the 5th and 6th grades with temporary (until Gibbs is complete) modular classrooms at Hardy, Thompson, and Ottoson.

Steps:

- Temporary leased modular classrooms at Thompson school year 2016-17 and more in 2017-18
- Temporary leased modular classrooms at Hardy school year 2017-18
- Relocate 2 SLC spaces from Brackett to Peirce school year 2017-18
- Temporary leased modular classrooms at Ottoson for school year 2016-17
- Renovate Gibbs School to accept 5th and 6th Grades in school year 2018-19
- High School planning schedule to be determined with MSBA

A sizable addition of classrooms would be required to accommodate approximately 550 fifth graders. The school property is 2.6 acres and an addition the size of what would be required would absorb most of the parking and likely the basketball court. The addition/renovations would not include expansion of the core interior shared spaces, Cafeteria, Gymnasium, Library, Art, and Music, and the current configuration would not accommodate 1100 students.

See **Appendix E** for a spreadsheet graphic representation of the schemes. See **Appendix F** for the potential classroom layout at Gibbs School.

Costs

At this time only rough comparison cost implications have been developed to begin to understand the potential future impact of each of the schemes; see **Appendix E**. Comparative costs are developed as a helpful tool to understand the order of magnitude of each proposed scheme as it compares to the others. They are not cost estimates. Cost estimates are not a required scope of the space planning effort at this time. The comparative costs are shown within a high-low range, again to provide an order of magnitude within which to compare the various space planning schemes. The following assumptions were used:

Type	Low	High
New construction	\$350/sf + 20% soft costs =\$390/sf	\$375/sf + 20% soft costs =\$450/sf
Renovation	\$175/sf + 20% soft costs =\$210/sf	\$250/sf + 20% soft costs =\$300/sf
Purchased modular*	~\$350/sf	~\$420/sf
Leased modular*	~\$80/sf + ~\$38/sf/year	~\$92/sf + ~\$44/sf/year

*The leased and purchased modular classroom costs noted are for stacked (multistory) modular construction; an increase of 33% is used to capture the “stack factor”. Additionally, the value used for the purchased modular classrooms assumes upgrades to the typical manufactured classroom module. Upgrades may include increased R-value of the exterior wall insulation, improved window performance and roofing material, and higher efficiency (and quieter), longer-life mechanical equipment; an increase of 50% is used to capture the upgrade factor.

The comparative costs do not include escalation or costs for any upgrades that may be required to the existing school buildings to receive modular classroom additions in order to meet current building codes. Additionally, the comparative costs do not include the temporary modular construction at Stratton Elementary School; this cost is carried separately in the Stratton renovation project budget.

Arlington Public Schools

POPULATION AND ENROLLMENT FORECASTS, 2015-16 THROUGH 2024-25

Prepared by:

Jerome N. McKibben, Ph.D.

McKibben Demographic Research

Rock Hill, South Carolina

Executive Summary – Arlington Public Schools Population and Enrollment Forecasts

1. The total fertility rate for the Arlington Public Schools district over the life of the forecasts is below replacement level. (1.92 vs. the replacement level of 2.1)
2. Most in-migration to the district continues to occur in the 0-to-9 and 30-to-44 year old age groups.
3. The local 18-to-24 year old population continues to leave the district, going to college or moving to other urbanized areas. This population group accounts for the largest segment of the service area's out migration flow.
4. The primary factor causing the district's enrollment to increase is the steady level of in-migration of young households/families and an increase in the number of households over age 70 that are out-migrating
5. Changes in year-to-year enrollment (at least for the next 5 years) will primarily be due to larger cohorts entering and moving through the school system in conjunction with smaller cohorts leaving the system.
6. The elementary enrollment will begin a slight decline after 2020.
7. The median age of the population will increase from 41.8 in 2010 to 43.0 in 2025.
8. The primary cause in the rise of the high school enrollment after 2017 is due to the wave of relatively large grade cohort currently in the elementary and middle school grades.



APPENDIX A

9. Even if the district continues to have a modest level of annual new home construction, the rate, magnitude and price of existing home sales will become the increasingly dominant factor affecting the amount of population and enrollment change.
10. Total district enrollment is forecasted to increase by 728 students, or 14.0%, between 2014-15 and 2019-20. Total enrollment will grow by 162 students, or 2.7%, from 2019-20 to 2024-25.

Chart 1: Permitted Housing Units, Town of Arlington, 2000-2014

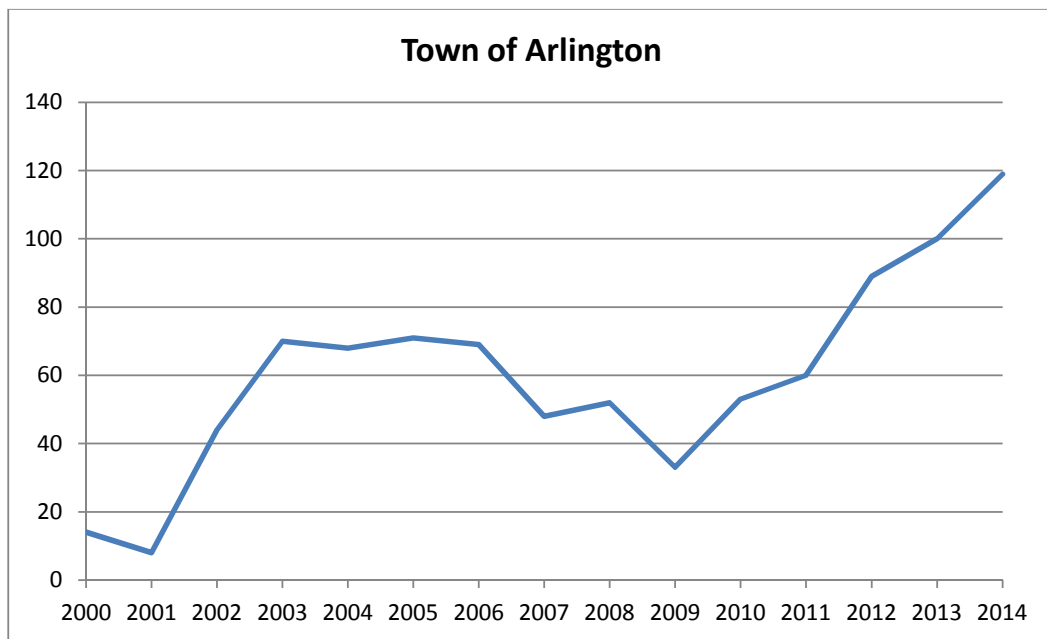

Table 1: Forecasted Elementary Area Population Change, 2010 to 2020

	2010	2015	<i>2010-2015</i> Change	2020	<i>2015-2020</i> Change	<i>2010-2020</i> Change
Bishop	6,728	6,760	0.5%	6,790	0.4%	0.9%
Brackett	5,915	5,990	1.3%	6,050	1.0%	2.3%
Dallin	5,391	5,460	1.3%	5,610	2.7%	4.1%
Hardy	7,031	7,310	3.8%	7,540	3.1%	7.2%
Peirce	4,448	4,550	2.2%	4,640	2.0%	4.3%
Stratton	5,371	5,500	2.3%	5,590	1.6%	4.1%
Thompson	7,960	8,300	4.1%	8,610	3.7%	8.2%
Arlington Total	42,844	43,870	2.3%	44,830	2.2%	4.6%

Table 2: Household Characteristics by Elementary Area, 2010 Census

	HH w/ Pop Under 18	% HH w/ Pop Under 18	Total Households	Household Population	Persons Per Household
Bishop	793	26.3%	3017	6662	2.21
Brackett	846	36.2%	2339	5857	2.50
Dallin	745	36.1%	2061	5272	2.56
Hardy	774	23.4%	3313	7006	2.11
Peirce	537	25.0%	2150	4444	2.07
Stratton	656	28.1%	2337	5371	2.30
Thompson	918	24.5%	3752	7942	2.12
Arlington Total	5268	27.8%	18969	42553	2.24



APPENDIX A

Table 3: Householder Characteristics by Elementary Area, 2010 Census

	Percentage of Householders aged 35- 54	Percentage of Householders aged 65+	Percentage of Householders Who Own Homes
Bishop	36.2%	32.5%	63.1%
Brackett	45.6%	23.5%	78.2%
Dallin	45.6%	24.7%	84.6%
Hardy	41.1%	20.2%	46.2%
Peirce	41.0%	26.6%	61.7%
Stratton	41.7%	24.6%	71.7%
Thompson	42.4%	19.6%	42.9%
Arlington Total	41.7%	24.2%	61.3%

**Table 4: Percentage of Households that are Single Person Households and
Single Person Households that are Over Age 65 by Elementary Area, 2010 Census**

	Percentage of Single Person Households	Percentage of Single Person Households and are 65+
Bishop	37.8%	17.9%
Brackett	24.0%	9.0%
Dallin	23.7%	9.9%
Hardy	36.0%	10.8%
Peirce	41.7%	16.3%
Stratton	33.1%	10.1%
Thompson	37.6%	10.7%
Arlington Total	34.1%	12.1%

Table 5: Age Under One to Age Ten Population Counts, by Year of Age, by

Elementary Area: 2010 Census

	Under 1 year	1 year	2 years	3 years	4 years	5 years	6 years	7 years	8 years	9 years	10 years
Bishop	79	76	68	84	86	68	79	82	89	70	85
Brackett	84	83	80	95	85	93	96	85	86	83	81
Dallin	79	68	72	75	81	91	70	72	69	80	67
Hardy	115	108	82	97	84	75	72	68	77	56	57
Peirce	57	62	74	55	51	54	55	46	39	49	49
Stratton	69	59	57	65	63	70	72	57	61	75	63
Thompson	143	103	105	98	102	89	79	63	90	76	57
Arlington	626	559	538	568	552	539	524	472	511	489	459

**Table 6: Comparison of District Enrollment by Grade with 2010 Census Counts
by Age, 2010-2014**

2010 census	Under 1 year	1 year	2 years	3 years	4 years	5 years	6 years	7 years	8 years	9 years	10 years	11 years	12 years	13 years
Arlington Total	626	559	538	568	552	539	524	472	511	489	459	442	458	449
2014 Enrollment		516 92.3%	482 89.6%	465 81.9%	477 86.4%	459 85.2%	428 81.7%	397 84.1%	341 66.7%	369 75.5%	306 66.7%	289 65.4%	310 67.7%	312 69.5%
2013 Enrollment			471 87.5%	472 83.1%	474 85.9%	458 85.0%	428 81.7%	423 89.6%	352 68.9%	385 78.7%	317 69.1%	280 63.3%	313 68.3%	303 67.5%
2012 Enrollment				454 79.9%	460 83.3%	446 82.7%	418 79.8%	424 89.8%	386 75.5%	374 76.5%	328 71.5%	326 73.8%	313 68.3%	298 66.4%
2011 Enrollment					450 81.5%	455 84.4%	427 81.5%	429 90.9%	390 76.3%	415 84.9%	349 76.0%	331 74.9%	346 75.5%	300 66.8%
2010 enrollment						448 83.1%	441 84.2%	433 91.7%	395 77.3%	427 87.3%	360 78.4%	344 77.8%	347 75.8%	360 80.2%



Arlington Public Schools - Methodology and Assumptions

McKibben Demographic Research - May 2015

INTRODUCTION

By demographic principle, distinctions are made between projections and forecasts. A projection extrapolates the past (and present) into the future with little or no attempt to take into account any factors that may impact the extrapolation (e.g., changes in fertility rates, housing patterns or migration patterns) while a forecast results when a projection is modified by reasoning to take into account the aforementioned factors.

To maximize the use of this study as a planning tool, the ultimate goal is not simply to project the past into the future, but rather to assess various factors' impact on the future. The future population and enrollment change of each school district is influenced by a variety of factors. Not all factors will influence the entire school district at the same level. Some may affect different areas at dissimilar magnitudes and rates causing changes at varying points of time within the same district. The forecaster's judgment, based on a thorough and intimate study of the district, has been used to modify the demographic trends and factors to more accurately predict likely changes. Therefore, strictly speaking, this study is a forecast, not a projection; and the amount of modification of the demographic trends varies between different areas of the district as well as within the timeframe of the forecast.

To calculate population forecasts of any type, particularly for smaller populations such as a school district, realistic suppositions must be made as to what the future will bring in terms of age specific fertility rates and residents' demographic behavior at certain points of the life course. The demographic history of the school district and its interplay with the social and economic history of the area is the starting point and basis of most of these suppositions particularly on key factors such as the age structure of the area. The unique nature of each district's and attendance area's demographic composition and rate of change over time must be assessed and understood to be factors throughout the life of the forecast series. Moreover, no two populations, particularly at the school district and attendance area level, have exactly the same characteristics.

The manifest purpose of these forecasts is to ascertain the demographic factors that will ultimately influence the enrollment levels in the district's schools. There are of course, other non-demographic factors that affect enrollment levels over time. These factors include, but are not limited to transfer policies within the district; student transfers to and from neighboring districts; placement of "special programs" within school facilities that may serve students from outside the attendance area; state or federal mandates that dictate the movement of students from one facility to another (No Child Left Behind is an excellent example of this factor); the development of charter schools in the district; the prevalence of home schooling in the area; and the dynamics of local private schools.

Unless the district specifically requests the calculation of forecasts that reflect the effects of changes in these non-demographic factors, their influences are held constant

APPENDIX A

for the life of the forecasts. Again, the main function of these forecasts is to determine what impact demographic changes will have on future enrollment. It is quite possible to calculate special “scenario” forecasts to measure the impact of school policy modifications as well as planned economic and financial changes. However in this case the results of these population and enrollment forecast are meant to represent the most likely scenario for changes over the next 10 years in the district and its attendance areas.

The first part of the report will examine the assumptions made in calculating the population forecasts for the Arlington Public Schools. Since the results of the population forecasts drive the subsequent enrollment forecasts, the assumptions listed in this section are paramount to understanding the area’s demographic dynamics. The remainder of the report is an explanation and analysis of the district's population forecasts and how they will shape the district's grade level enrollment forecasts.

DATA

The data used for the forecasts come from a variety of sources. The Arlington Public Schools provided enrollments by grade and attendance center for the school years 2010-2011 to 2014-15. Birth and death data for the years 2000 through 2012 were obtained from the Massachusetts Department of Health and Human Services. The net migration values were calculated using Internal Revenue Service migration reports for the years 2000 through 2011. The data used for the calculation of migration models came from the United States Bureau of the Census, 2005 to 2010, and the models were designed using demographic and economic factors. The base age-sex population counts used are from the results of the 2010 Census.

Recently the Census Bureau began releasing annual estimates of demographic variables at the block group and tract level from the American Community Survey (ACS). There has been wide scale reporting of these results in the national, state and local media. However, due to the methodological problems the Census Bureau is experiencing with their estimates derived from ACS data, particularly in areas with a population of less than 60,000, the results of the ACS are not used in these forecasts. For example, given the sampling framework used by the Census Bureau, each year only 600 of the over 19,000 current households in the district would have been included. For comparison 2,800 households in the district were included in the sample for the long form questionnaire in the 2000 Census. As a result of this small sample size, the ACS survey result from the last 5 years must be aggregated to produce the tract and block group estimates.

To develop the population forecast models, past migration patterns, current age specific fertility patterns, the magnitude and dynamics of the gross migration, the age specific mortality trends, the distribution of the population by age and sex, the rate and type of existing housing unit sales, and future housing unit construction are considered to be primary variables. In addition, the change in household size relative to the age structure of the forecast area was addressed. While there was a slight drop in the average household size in the Arlington Public Schools as well as most other areas of the state during the previous 20 years, the rate of this decline has been forecasted to slow over the next ten years.

APPENDIX A

ASSUMPTIONS

For these forecasts, the mortality probabilities are held constant at the levels calculated for the year 2010. While the number of deaths in an area are impacted by and will change given the proportion of the local population over age 65, in the absence of an extraordinary event such as a natural disaster or a breakthrough in the treatment of heart disease, death rates rarely move rapidly in any direction, particularly at the school district or attendance area level. Thus, significant changes are not foreseen in district's mortality rates between now and the year 2024. Any increases forecasted in the number of deaths will be due primarily to the general aging of the district's population and specifically to the increase in the number of residents aged 65 and older.

Similarly, fertility rates are assumed to stay fairly constant for the life of the forecasts. Like mortality rates, age specific fertility rates rarely change quickly or dramatically, particularly in small areas. Even with the recently reported rise in the fertility rates of the United States, overall fertility rates have stayed within a 10% range for most of the last 40 years. In fact, the vast majority of year to year change in an area's number of births is due to changes in the number of women in child bearing ages (particularly ages 20-29) rather than any fluctuation in an area's fertility rate.

The total fertility rate (TFR), the average number of births a woman will have in her lifetime, is estimated to be 1.92 for the total district for the ten years of the population forecasts. A TFR of 2.1 births per woman is considered to be the theoretical "replacement level" of fertility necessary for a population to remain constant in the absence of in-migration. Therefore, in the absence of migration, fertility alone would be

insufficient to maintain the current level of population and enrollment within the Arlington Public Schools over the course of the forecast period.

A close examination of data for the Arlington Public Schools has shown the age specific pattern of net migration will be nearly constant throughout the life of the forecasts. While the number of in and out migrants has changed in past years for the Arlington Public Schools (and will change again over the next 10 years), the basic age pattern of the migrants has stayed nearly the same over the last 30 years. Based on the analysis of data it is safe to assume this age specific migration trend will remain unchanged into the future. This pattern of migration shows most of the local out-migration occurring in the 18-to-24 year old age group as young adults leave the area to go to college or move to other urbanized areas. The second group of out-migrants is those householders aged 70 and older who are downsizing their residences. Most of the local in-migration occurs in the 0-to-9 and 30-44 age groups (bulk of which is from areas within 75 miles of the Arlington Public Schools) primarily consisting of younger adults and their children.

As the Middlesex County area is not currently contemplating any major expansions or contractions, the forecasts also assume that the current economic, political, social, and environmental factors, as well as the transportation and public works infrastructure (with a few notable exceptions) of the Arlington Public Schools and its attendance areas will remain the same through the year 2024. Below is a list of assumptions and issues that are specific to the Arlington Public Schools. These issues have been used to modify the population forecast models to more accurately predict the

APPENDIX A

impact of these factors on each area's population change. Specifically, the forecasts for the Arlington Public Schools assume that throughout the study period:

- a. There will be no short term economic recovery in the next 18 months and the national, state or regional economy does not go into deep recession at anytime during the 10 years of the forecasts; (Deep recession is defined as four consecutive quarters where the GDP contracts greater than 1% per quarter)
- b. Interest rates have reached an historic low and will not fluctuate more than one percentage point in the short term; the interest rate for a 30 year fixed home mortgage stays below 5.0%;
- c. The rate of mortgage approval stays at 1999-2003 levels and lenders do not return to "sub-prime" mortgage practices;
- d. There are no additional restrictions placed on home mortgage lenders or additional bankruptcies of major credit providers;
- e. The rate of housing foreclosures does not exceed 125% of the 2005-2007 average of Middlesex County for any year in the forecasts;
- f. All currently planned, platted, and approved housing developments are built out and completed by 2023. All housing units constructed are occupied by 2024;
- g. The unemployment rates for the Metropolitan Boston will remain below 6.0% for the 10 years of the forecasts;
- h. The rate of students transferring into and out of the Arlington Public Schools will remain at the 2010-11 to 2014-15 average;
- i. The district's current policy on assigning schools to children living in the "buffer zones" remains the constant for the life of the forecasts;

- j. The inflation rate for gasoline will stay below 5% per year for the 10 years of the forecasts;
- k. There will be no building moratorium within the district;
- l. Businesses within the district and the Arlington Public Schools area will remain viable;
- m. The number of existing home sales in the district that are a result of “distress sales” (homes worth less than the current mortgage value) will not exceed 20% of total homes sales in the district for any given year;
- n. Housing turnover rates (sale of existing homes in the district) will remain at their current levels. The majority of existing home sales are made by home owners over the age of 55;
- o. Private school and home school attendance rates will remain constant;
- p. The recent decline in new home construction has ended and building rates have stabilized;
- q. The rate of foreclosures for commercial property remains at the 2004-2008 average for Middlesex County;

If a major employer in the district or in the Greater Boston Metropolitan Area closes, reduces or expands its operations, the population forecasts would need to be adjusted to reflect the changes brought about by the change in economic and employment conditions. The same holds true for any type of natural disaster, major change in the local infrastructure (e.g., highway construction, water and sewer expansion, changes in zoning regulations etc.), a further economic downturn, any additional weakness in the housing market or any instance or situation that causes rapid



APPENDIX A

and dramatic population changes that could not be foreseen at the time the forecasts were calculated.

The high proportion of high school graduates from the Arlington Public Schools that attend college or move to urban areas outside of the district for employment is a significant demographic factor. Their departure is a major reason for the extremely high out-migration in the 18 to 24 age group, and was taken into account when calculating these forecasts. The out-migration of graduating high school seniors is expected to continue over the period of the forecasts and the rate of out-migration has been forecasted to remain the same over the life of the forecast series.

Finally, all demographic trends (i.e., births, deaths, and migration) are assumed to be linear in nature and annualized over the forecast period. For example, if 1,000 births are forecasted for a 5-year period, an equal number, or proportion of the births are assumed to occur every year, 200 per year. Actual year-to-year variations do and will occur, but overall year to year trends are expected to be constant.

METHODOLOGY

The population forecasts presented in this report are the result of using the Cohort-Component Method of population forecasting (Siegel, and Swanson, 2004: 561-601) (Smith et. al. 2004). As stated in the **INTRODUCTION**, the difference between a projection and a forecast is in the use of explicit judgment based upon the unique features of the area under study. Strictly speaking, a cohort projection refers to the future population that would result if a mathematical extrapolation of historical trends. Conversely, a cohort-component forecast refers to the future population that is expected because of a studied and purposeful selection of the components of change (i.e., births,

deaths, and migration) and forecast models are developed to measure the impact of these changes in each specific geographic area.

Five sets of data are required to generate population and enrollment forecasts.

These five data sets are:

- a. a base-year population (here, the 2010 Census population for Arlington Public Schools and its attendance areas);
- b. a set of age-specific fertility rates for the district to be used over the forecast period and its attendance areas;
- c. a set of age-specific survival (mortality) rates for the district and its attendance areas;
- d. a set of age-specific migration rates for the district and its attendance areas; and;
- e. the historical enrollment figures by grade.

The most significant and difficult aspect of producing enrollment forecasts is the generation of the population forecasts in which the school age population (and enrollment) is embedded. In turn, the most challenging aspect of generating the population forecasts is found in deriving the rates of change in fertility, mortality, and migration. From the standpoint of demographic analysis, the Arlington Public Schools is classified as a “small area” populations (as compared to the population of the state of Massachusetts or to that of the United States). Small area population forecasts are more complicated to calculate because local variations in fertility, mortality, and migration may be more irregular than those at the regional, state or national scale. Especially challenging is the forecast of the migration rates for local areas, because changes in the area's socioeconomic characteristics can quickly change from past and current patterns (Peters and Larkin, 2002.)

APPENDIX A

The population forecasts for Arlington Public Schools were calculated using a cohort-component method with the populations divided into male and female groups by five-year age cohorts that range from 0-to-4 years of age to 85 years of age and older (85+). Age- and sex-specific fertility, mortality, and migration models were constructed to specifically reflect the unique demographic characteristics of each of the attendance areas in the Arlington Public Schools.

The enrollment forecasts were calculated using a modified average survivorship method. Average survivor rates (i.e., the proportion of students who progress from one grade level to the next given the average amount of net migration for that grade level) over the previous five years of year-to-year enrollment data were calculated for grades two through twelve. This procedure is used to identify specific grades where there are large numbers of students changing facilities for non-demographic factors, such as private school transfers or enrollment in special programs.

The survivorship rates were modified or adjusted to reflect the average rate of forecasted in and out migration of 5-to-9, 10-to-14 and 15-to-17 year old cohorts to each of the attendance centers in Arlington Public Schools for the period 2010 to 2015. These survivorship rates then were adjusted to reflect the forecasted changes in age-specific migration the district should experience over the next five years. These modified survivorship rates were used to project the enrollment of grades 2 through 12 for the period 2015 to 2020. The survivorship rates were adjusted again for the period 2020 to 2025 to reflect the predicted changes in the amount of age-specific migration in the district for the period.

The forecasted enrollments for kindergarten and first grade are derived from the 5-to-9 year old population of the age-sex population forecast at the elementary attendance center district level. This procedure allows the changes in the incoming grade sizes to be factors of forecasted population change and not an extrapolation of previous class sizes. Given the potentially large amount of variation in Kindergarten enrollment due to parental choice, changes in the state's minimum age requirement, and differing district policies on allowing children to start Kindergarten early, first grade enrollment is deemed to be a more accurate and reliable starting point for the forecasts. (McKibben, 1996) The level of the accuracy for both the population and enrollment forecasts at the school district level is estimated to be $\pm 2.0\%$ for the life of the forecasts.

REFERENCES

McKibben, J.

The Impact of Policy Changes on Forecasting for School Districts. Population Research and Policy Review, Vol. 15, No. 5-6, December 1996

McKibben, J., M. Gann, and K. Faust.

The Baby Boomlet's Role in Future College Enrollment. American Demographics, June 1999.

Peters, G. and R. Larkin

Population Geography. 7th Edition. Dubuque, IA: Kendall Hunt Publishing. 2002.

Siegel, J. and D. Swanson

The Methods and Materials of Demography: Second Edition, Academic Press: New York, New York. 2004.

Smith, S., J. Tayman and D. Swanson

State and Local Population Projections, Academic Press, New York, New York. 2001.

Arlington, Massachusetts Total Population – 2010 Census

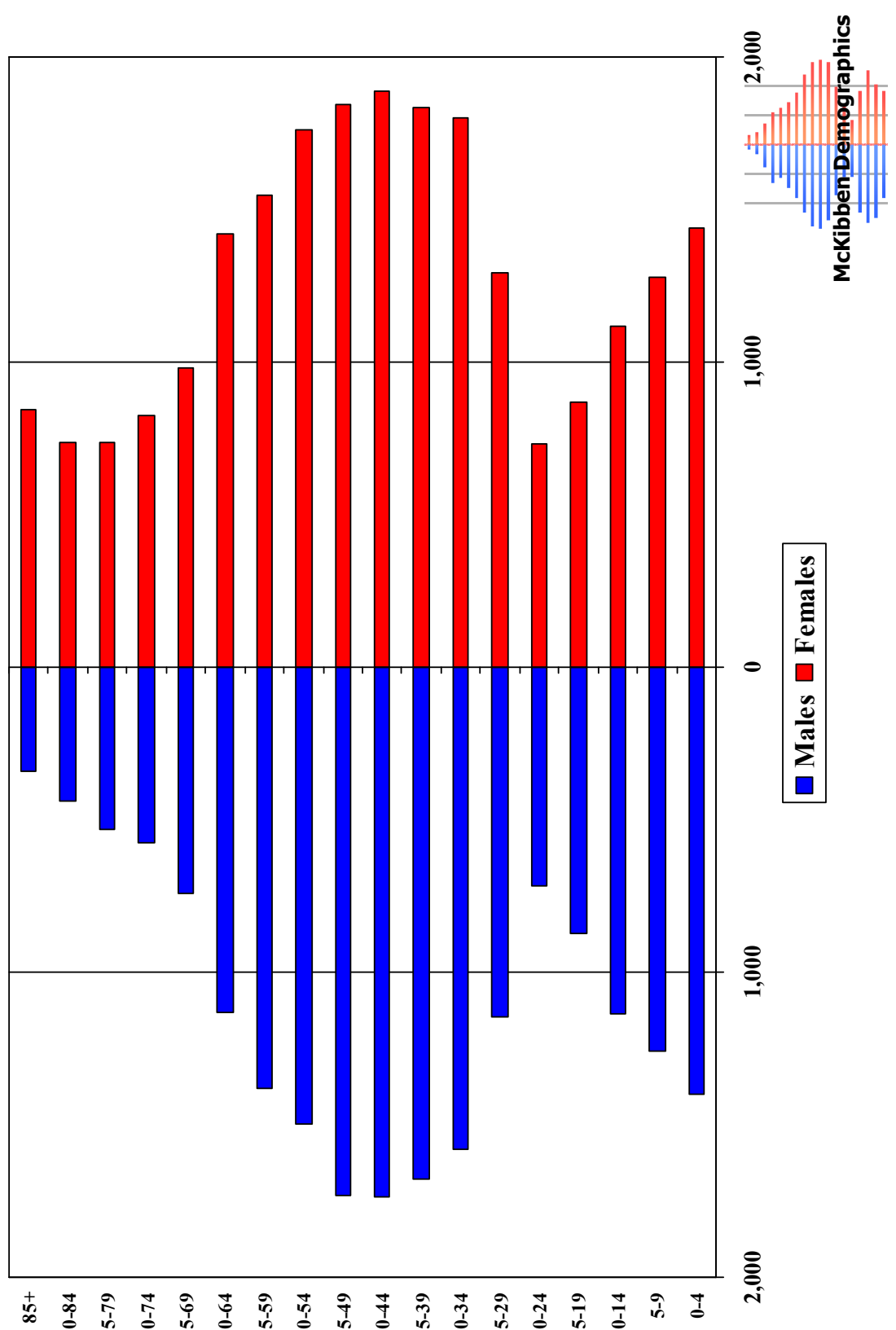

APPENDIX A

Bishop Area and Buffer Zone – 2010 Census

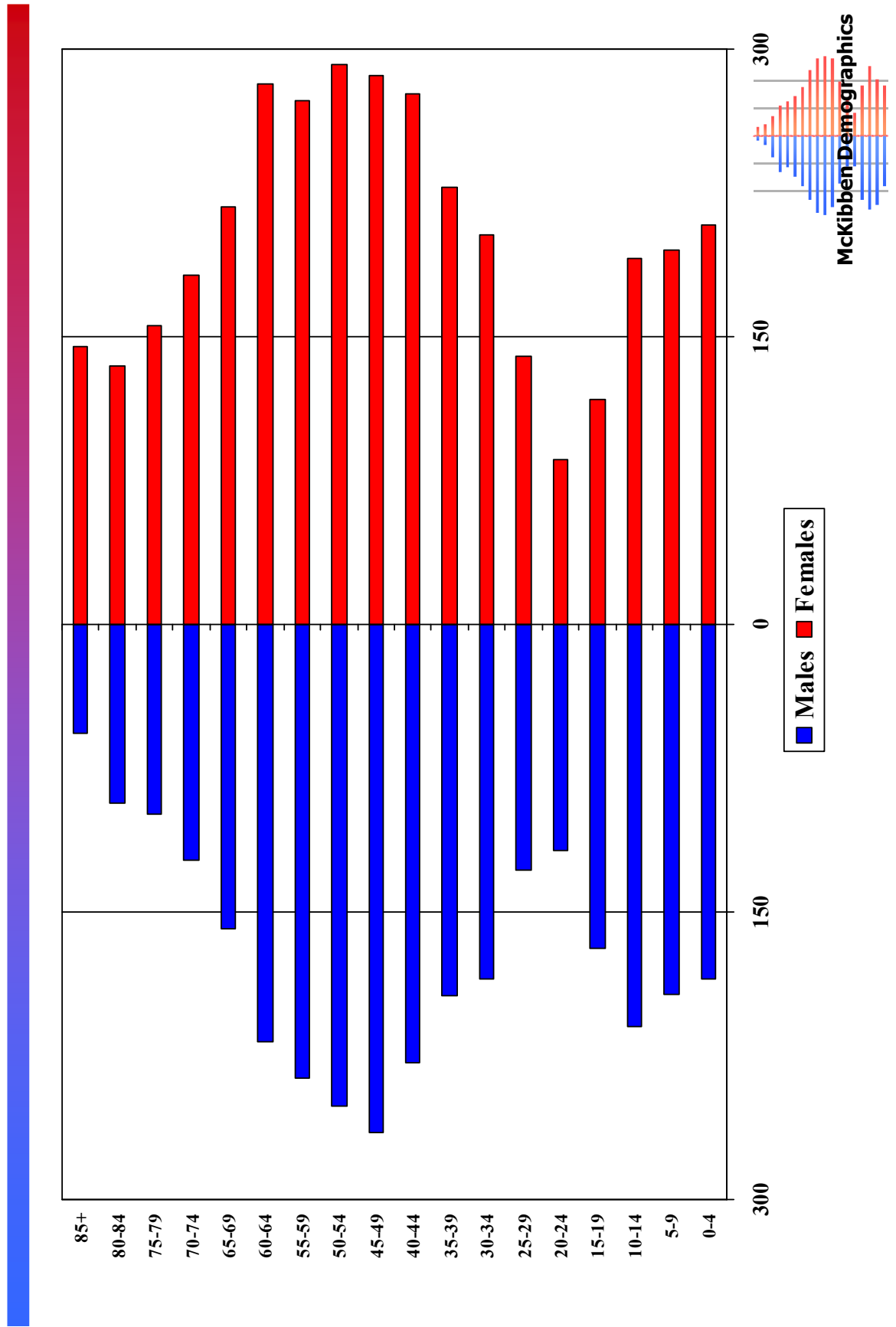

Brackett Area and Buffer Zone – 2010 Census

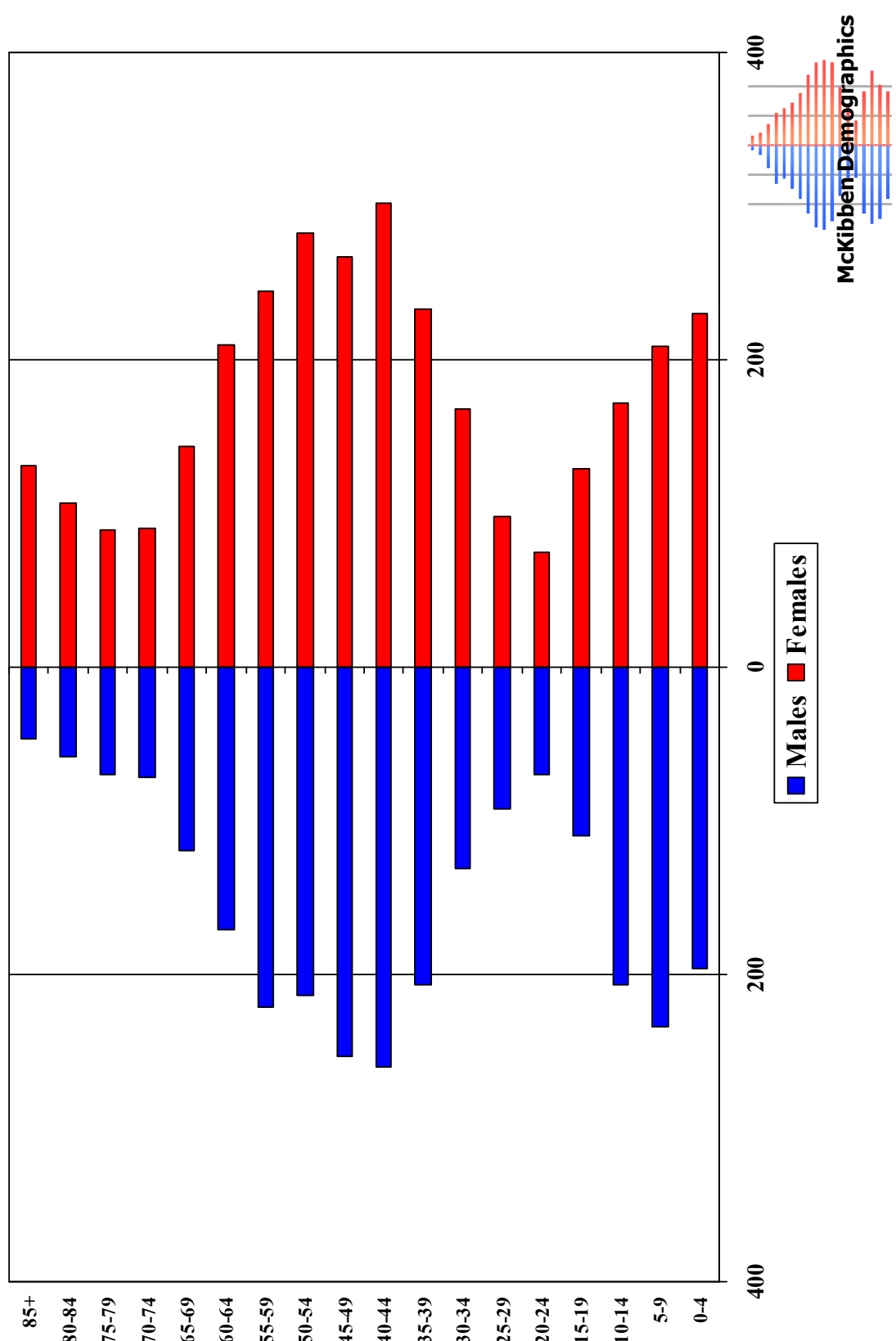

APPENDIX A

Dallin Area and Buffer Zone – 2010 Census

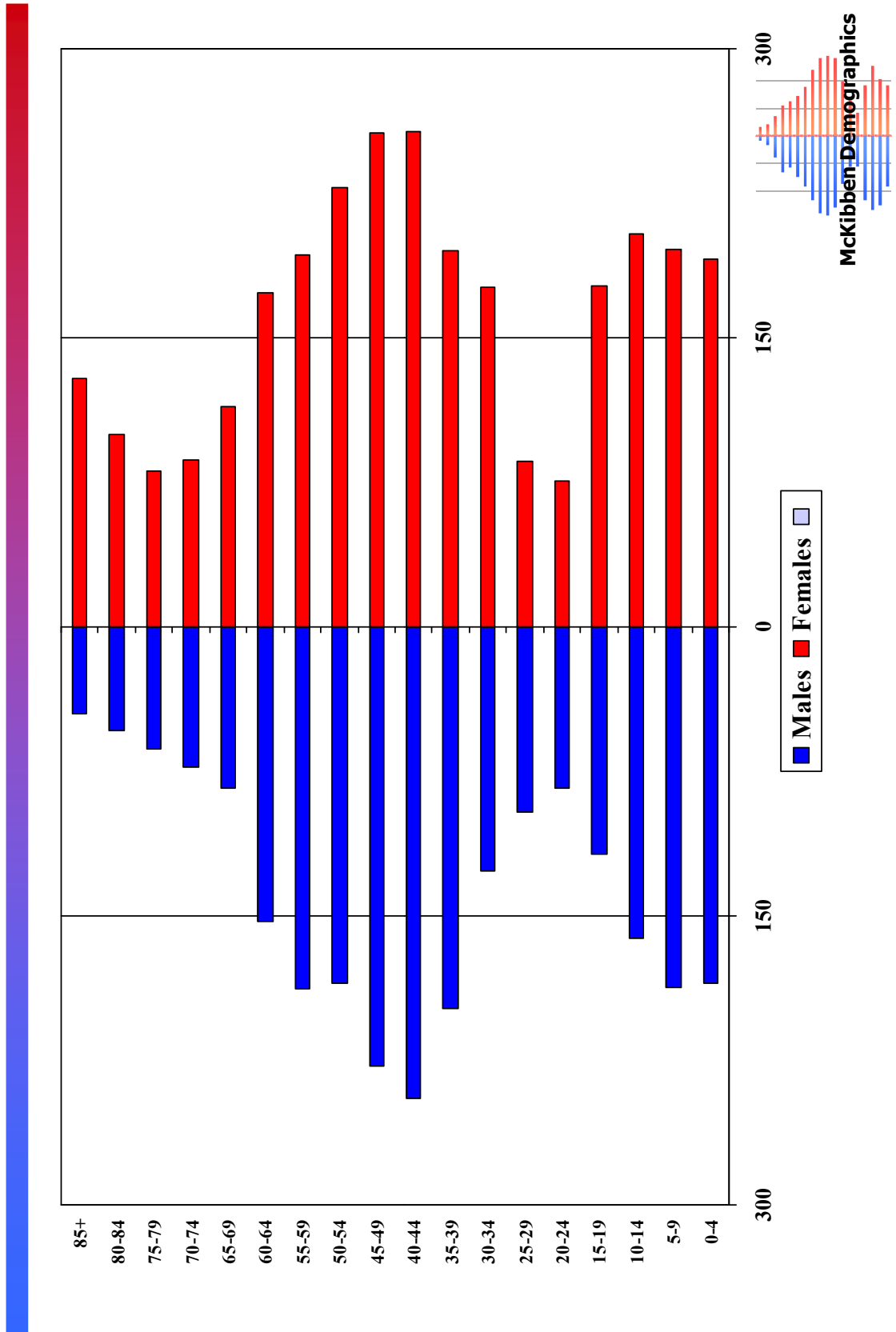

Hardy Area and Buffer Zone – 2010 Census

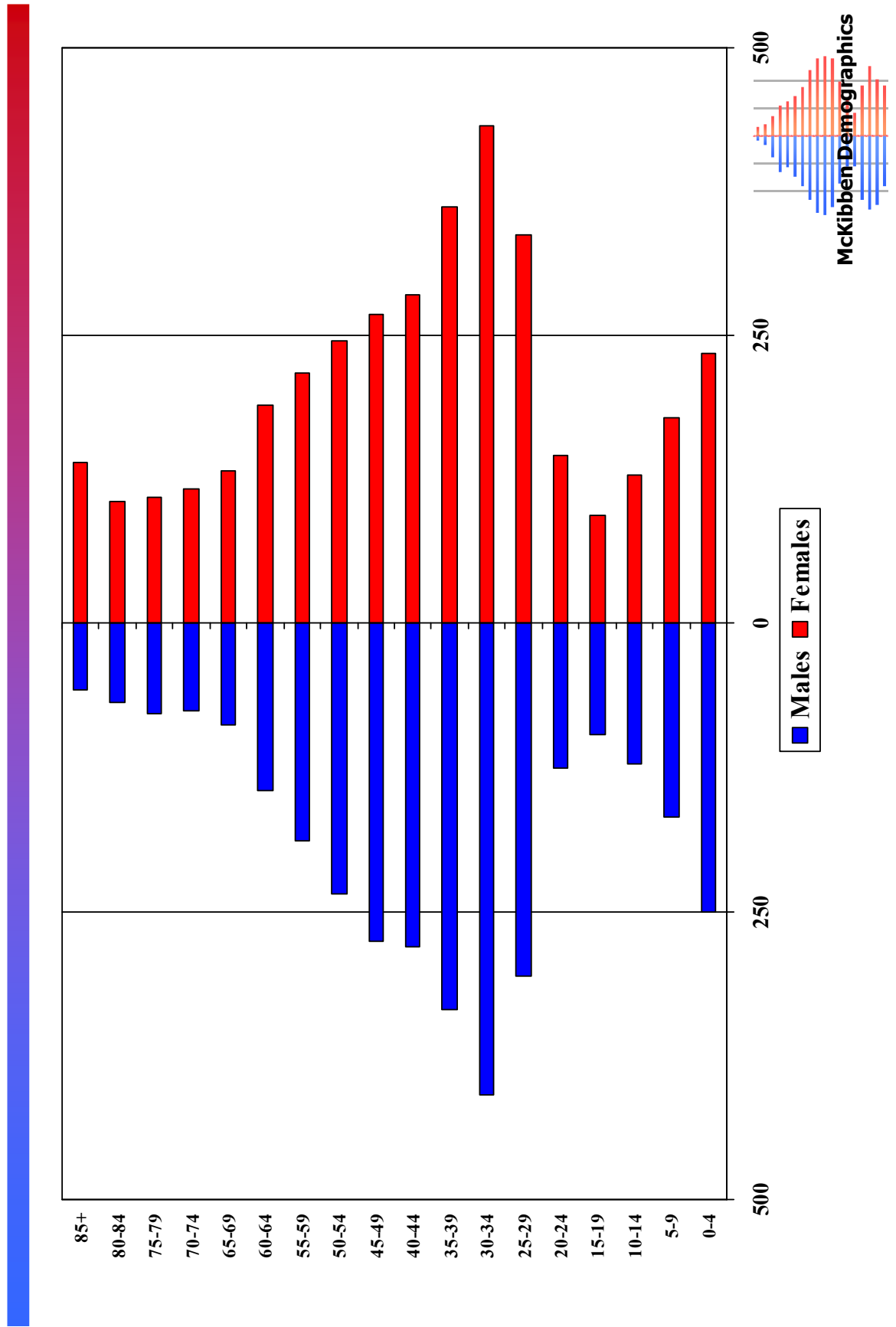

APPENDIX A

Peirce Area and Buffer Zone – 2010 Census

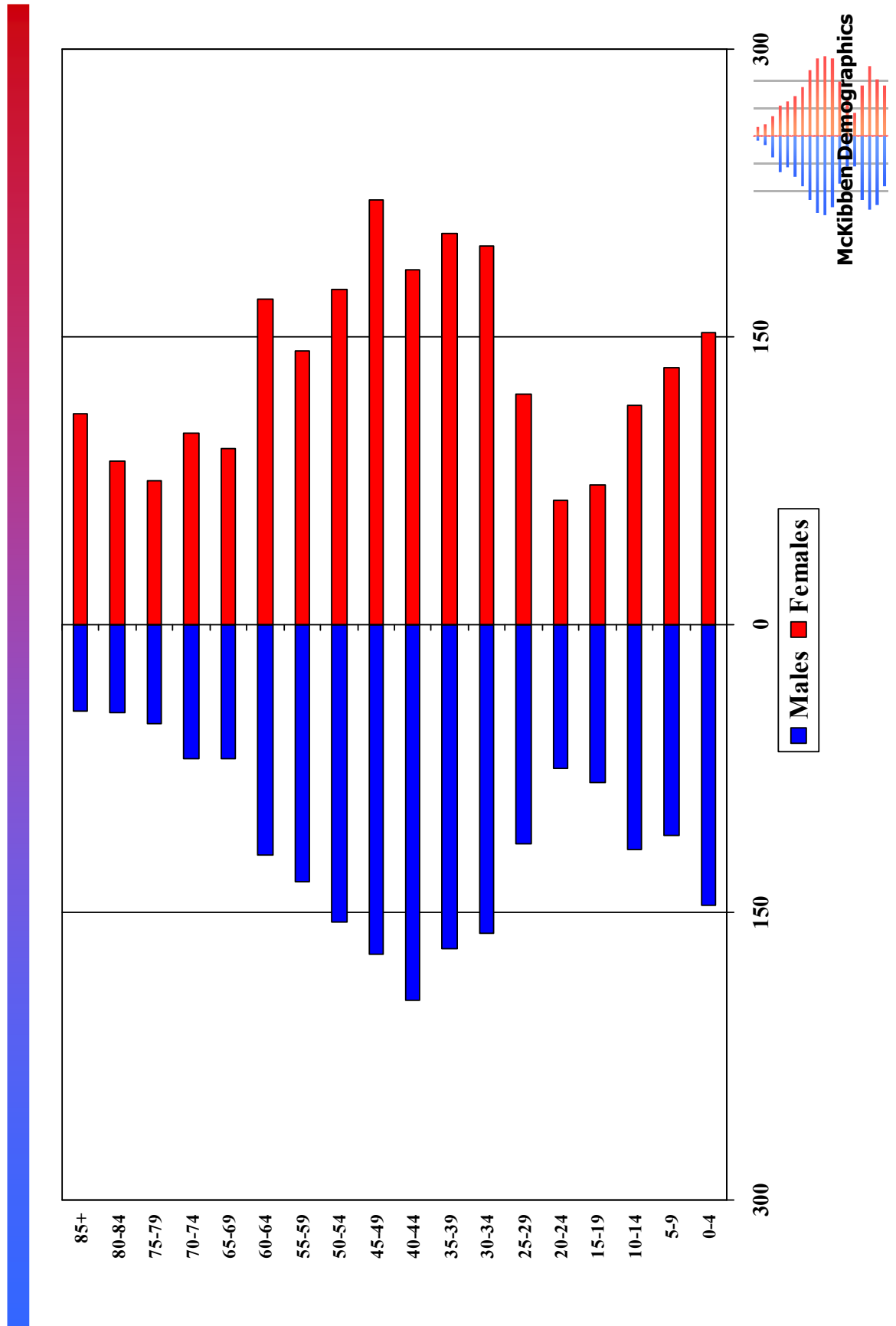

Stratton Area and Buffer Zone – 2010 Census

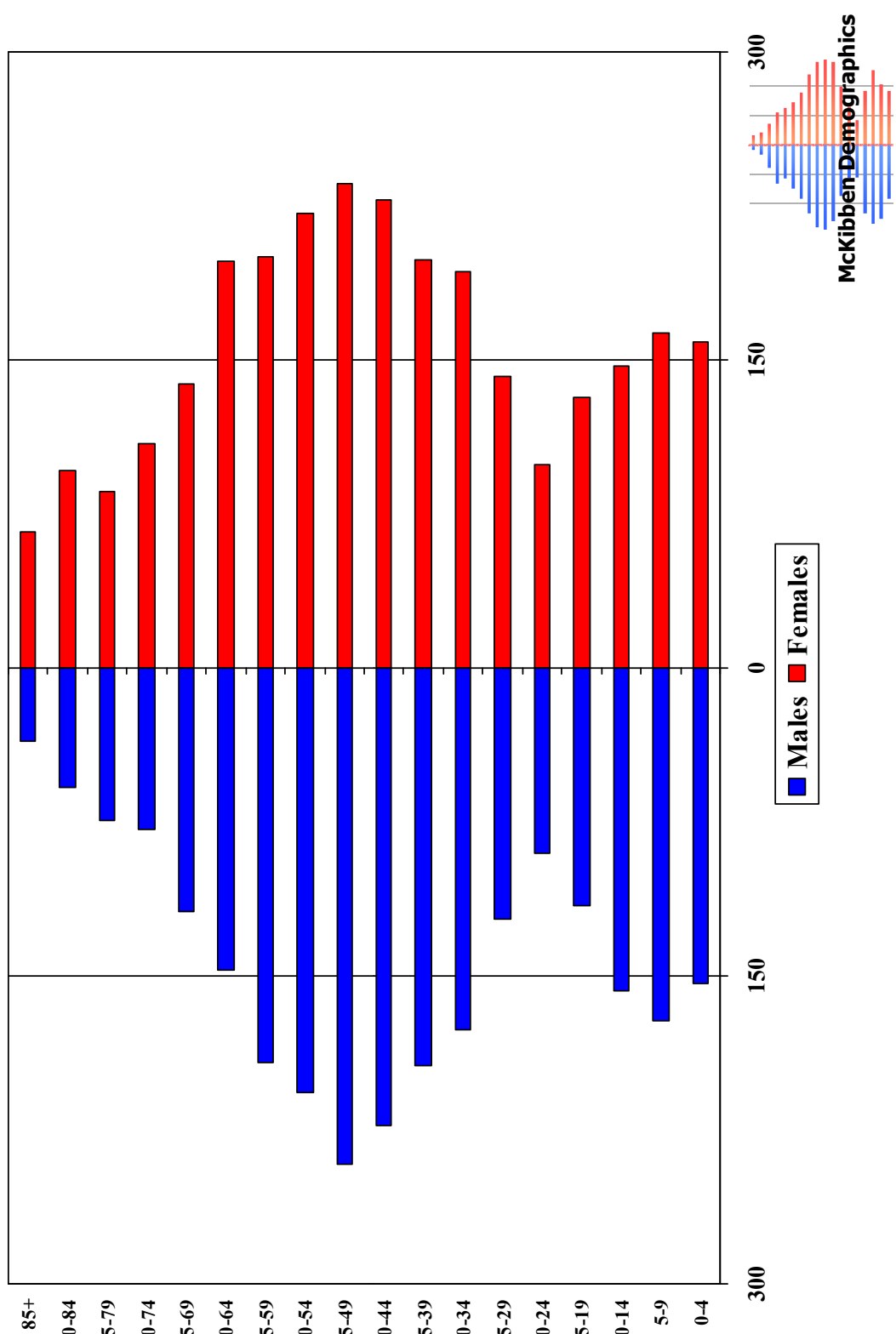

APPENDIX A

Thompson Area and Buffer Zone – 2010 Census

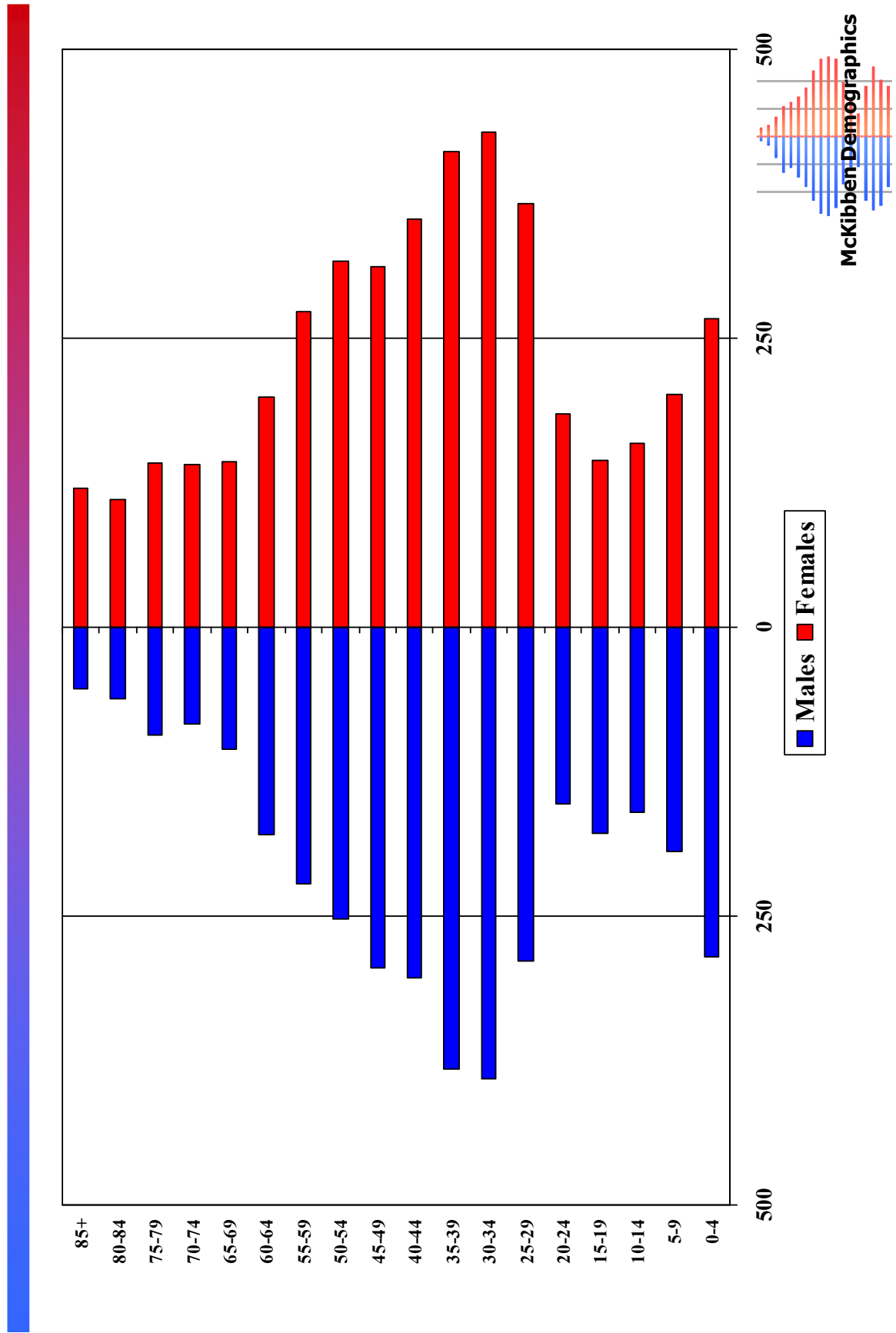

Arlington Public Schools

May 2015

	2010	2015	2020	2025
Males				
0-4	1,402	1,440	1,370	1,240
5-9	1,258	1,470	1,550	1,450
10-14	1,136	1,280	1,500	1,580
15-19	871	930	1,070	1,250
20-24	715	690	740	850
25-29	1,148	1,170	1,170	1,190
30-34	1,580	1,490	1,520	1,480
35-39	1,678	1,540	1,440	1,490
40-44	1,738	1,570	1,410	1,350
45-49	1,731	1,680	1,500	1,370
50-54	1,499	1,700	1,650	1,480
55-59	1,382	1,460	1,640	1,600
60-64	1,133	1,270	1,350	1,540
65-69	743	990	1,120	1,220
70-74	577	620	820	950
75-79	530	420	460	670
80-84	441	360	290	340
85+	342	400	400	330
Total	19,904	20,480	21,000	21,380
Females				
0-4	1,441	1,400	1,310	1,210
5-9	1,277	1,490	1,490	1,390
10-14	1,116	1,310	1,530	1,510
15-19	867	910	1,090	1,290
20-24	732	690	740	870
25-29	1,291	1,200	1,160	1,180
30-34	1,798	1,650	1,560	1,500
35-39	1,832	1,750	1,630	1,530
40-44	1,886	1,730	1,640	1,530
45-49	1,845	1,840	1,680	1,620
50-54	1,761	1,820	1,810	1,670
55-59	1,545	1,730	1,800	1,790
60-64	1,421	1,450	1,630	1,700
65-69	982	1,290	1,310	1,540
70-74	826	880	1,160	1,200
75-79	739	710	750	1,030
80-84	739	580	550	610
85+	842	960	990	960
Total	22,940	23,390	23,830	24,130
Total				
0-4	2,843	2,840	2,680	2,450
5-9	2,535	2,960	3,040	2,840
10-14	2,252	2,590	3,030	3,090
15-19	1,738	1,840	2,160	2,540
20-24	1,447	1,380	1,480	1,720
25-29	2,439	2,370	2,330	2,370
30-34	3,378	3,140	3,080	2,980
35-39	3,510	3,290	3,070	3,020
40-44	3,624	3,300	3,050	2,880
45-49	3,576	3,520	3,180	2,990
50-54	3,260	3,520	3,460	3,150
55-59	2,927	3,190	3,440	3,390
60-64	2,554	2,720	2,980	3,240
65-69	1,725	2,280	2,430	2,760
70-74	1,403	1,500	1,980	2,150
75-79	1,269	1,130	1,210	1,700
80-84	1,180	940	840	950
85+	1,184	1,360	1,390	1,290
Total	42,844	43,870	44,830	45,510
Median Age	41.8	42.3	42.5	43.0
Births	2,440	2,280	2,160	2,000
Deaths	1,940	1,960	1,600	1,560
Natural Increase	500	320	560	440
Net Migration	610	620	560	720
Change	1,110	940	1,120	1,160

Differences between period Totals may not equal Change due to rounding.



APPENDIX A

Bishop Elementary

May 2015

	2010	2015	2020	2025
Males				
0-4	185	200	210	190
5-9	193	220	240	230
10-14	210	200	230	240
15-19	169	180	170	200
20-24	118	120	130	130
25-29	128	150	150	160
30-34	185	170	190	180
35-39	194	210	190	210
40-44	229	190	200	190
45-49	265	230	190	200
50-54	251	260	220	190
55-59	237	240	250	220
60-64	218	220	220	230
65-69	159	190	190	200
70-74	123	130	160	160
75-79	99	90	100	130
80-84	93	60	60	70
85+	57	70	60	50
Total	3,113	3,130	3,160	3,180
Females				
0-4	208	200	200	180
5-9	195	240	230	230
10-14	191	210	250	240
15-19	117	160	170	220
20-24	86	70	110	140
25-29	140	120	100	140
30-34	203	180	160	130
35-39	228	220	210	180
40-44	277	230	220	210
45-49	286	280	230	220
50-54	292	280	270	220
55-59	273	290	280	270
60-64	282	250	270	260
65-69	218	260	230	250
70-74	182	200	240	210
75-79	156	160	170	210
80-84	135	120	120	130
85+	145	160	170	170
Total	3,615	3,630	3,630	3,610
Total				
0-4	393	400	410	370
5-9	388	460	470	460
10-14	401	410	480	480
15-19	286	340	340	420
20-24	204	190	240	270
25-29	269	270	250	300
30-34	388	350	350	310
35-39	422	430	400	390
40-44	506	420	420	400
45-49	551	510	420	420
50-54	543	540	490	410
55-59	509	530	530	490
60-64	500	470	490	490
65-69	377	450	420	450
70-74	305	330	400	370
75-79	254	250	270	340
80-84	229	180	180	200
85+	202	230	230	220
Total	6,728	6,760	6,790	6,790
Median Age	46.0	46.1	45.4	44.9
Births	290	280	280	280
Deaths	360	360	360	360
Natural Increase	-70	-80	-80	-80
Net Migration	110	110	90	90
Change	40	30	10	10

Differences between period Totals may not equal Change due to rounding.

Brackett Elementary

May 2015

	2010	2015	2020	2025
Males				
0-4	196	200	190	180
5-9	234	220	240	230
10-14	207	240	230	250
15-19	110	160	190	170
20-24	70	60	100	120
25-29	92	100	90	130
30-34	131	110	120	110
35-39	207	160	140	150
40-44	260	220	160	160
45-49	253	260	220	160
50-54	214	250	250	220
55-59	221	210	240	240
60-64	171	200	190	220
65-69	119	150	180	170
70-74	72	100	120	150
75-79	70	50	70	100
80-84	58	40	30	50
85+	47	50	50	40
Total	2,733	2,780	2,810	2,850
Females				
0-4	230	190	190	180
5-9	209	250	230	220
10-14	172	220	260	240
15-19	129	120	160	200
20-24	75	80	70	90
25-29	98	100	110	100
30-34	168	120	130	130
35-39	233	200	150	160
40-44	302	250	200	170
45-49	267	300	250	200
50-54	283	260	300	250
55-59	245	280	260	290
60-64	210	230	260	240
65-69	144	190	210	240
70-74	90	130	170	190
75-79	89	70	100	150
80-84	107	70	50	90
85+	131	150	140	120
Total	3,182	3,210	3,240	3,260
Total				
0-4	427	390	380	360
5-9	443	470	470	450
10-14	380	460	490	490
15-19	239	280	350	370
20-24	145	140	170	210
25-29	191	200	200	230
30-34	300	230	250	240
35-39	439	360	290	310
40-44	562	470	360	330
45-49	520	560	470	360
50-54	497	510	550	470
55-59	466	490	500	530
60-64	380	430	450	460
65-69	262	340	390	410
70-74	162	230	290	340
75-79	159	120	170	250
80-84	165	110	80	140
85+	178	200	190	160
Total	5,915	5,990	6,050	6,110
Median Age	43.5	44.9	45.7	45.9
Births	250	220	220	220
Deaths	270	270	270	270
Natural Increase	-20	-50	-50	-50
Net Migration	100	110	100	100
Change	80	60	50	50

Differences between period Totals may not equal Change due to rounding.



APPENDIX A

Dallin Elementary

May 2015

	2010	2015	2020	2025
Males				
0-4	185	180	180	170
5-9	187	210	210	200
10-14	162	190	220	220
15-19	118	140	170	190
20-24	84	50	70	100
25-29	96	100	70	90
30-34	127	140	150	110
35-39	198	160	170	170
40-44	245	200	160	170
45-49	228	240	190	150
50-54	185	220	240	190
55-59	188	180	220	230
60-64	153	170	160	210
65-69	84	130	150	150
70-74	73	70	110	130
75-79	63	50	50	90
80-84	54	40	30	30
85+	45	50	50	40
Total	2,473	2,520	2,600	2,640
Females				
0-4	191	180	170	170
5-9	196	210	210	190
10-14	204	200	220	210
15-19	177	180	180	200
20-24	76	110	120	110
25-29	86	90	130	130
30-34	176	130	140	170
35-39	195	210	170	170
40-44	257	190	210	160
45-49	256	260	190	210
50-54	228	250	250	190
55-59	193	220	250	250
60-64	173	180	210	240
65-69	114	160	160	200
70-74	87	100	140	150
75-79	81	70	80	120
80-84	100	60	50	60
85+	129	140	130	120
Total	2,918	2,940	3,010	3,050
Total				
0-4	376	360	350	340
5-9	382	420	420	390
10-14	366	390	440	430
15-19	295	320	350	390
20-24	160	160	190	210
25-29	181	190	200	220
30-34	303	270	290	280
35-39	393	370	340	340
40-44	501	390	370	330
45-49	484	500	380	360
50-54	413	470	490	380
55-59	381	400	470	480
60-64	326	350	370	450
65-69	197	290	310	350
70-74	160	170	250	280
75-79	144	120	130	210
80-84	155	100	80	90
85+	174	190	180	160
Total	5,391	5,460	5,610	5,690
Median Age	42.4	43.2	43.0	43.7
Births	280	280	270	
Deaths	250	240	240	
Natural Increase	30	40	30	
Net Migration	80	80	70	
Change	110	120	100	

Differences between period Totals may not equal Change due to rounding.

Hardy Elementary

May 2015

	2010	2015	2020	2025
Males				
0-4	250	260	240	210
5-9	168	250	260	240
10-14	122	160	240	250
15-19	96	100	130	200
20-24	125	140	140	150
25-29	306	280	300	280
30-34	409	360	340	350
35-39	335	350	300	290
40-44	281	270	280	250
45-49	276	250	240	280
50-54	234	270	240	230
55-59	189	230	260	240
60-64	145	170	220	250
65-69	88	130	150	200
70-74	76	70	100	130
75-79	78	50	50	80
80-84	69	50	30	40
85+	57	70	60	50
Total	3,305	3,460	3,580	3,720
Females				
0-4	234	250	230	200
5-9	179	230	250	230
10-14	129	170	220	240
15-19	94	110	140	190
20-24	146	130	150	160
25-29	338	310	290	290
30-34	432	400	370	350
35-39	362	370	340	310
40-44	285	300	310	290
45-49	268	250	270	310
50-54	245	270	250	270
55-59	218	240	260	250
60-64	190	200	230	250
65-69	133	170	180	230
70-74	117	120	150	170
75-79	110	100	100	130
80-84	106	80	70	80
85+	140	150	150	140
Total	3,725	3,850	3,960	4,090
Total				
0-4	485	510	470	410
5-9	347	480	510	470
10-14	251	330	460	490
15-19	191	210	270	390
20-24	271	270	290	310
25-29	644	590	590	570
30-34	841	760	710	700
35-39	697	720	640	600
40-44	566	570	590	540
45-49	544	500	510	590
50-54	479	540	490	500
55-59	406	470	520	490
60-64	335	370	450	500
65-69	220	300	330	430
70-74	193	190	250	300
75-79	187	150	150	210
80-84	175	130	100	120
85+	197	220	210	190
Total	7,031	7,310	7,540	7,810
Median Age	38.5	38.5	38.7	39.7
Births	480	440	440	440
Deaths	290	290	280	280
Natural Increase	190	150	160	160
Net Migration	100	100	90	90
Change	290	250	250	250

Differences between period Totals may not equal Change due to rounding.



APPENDIX A

Peirce Elementary

May 2015

	2010	2015	2020	2025
Males				
0-4	146	140	130	120
5-9	110	130	130	120
10-14	117	110	130	130
15-19	82	90	90	110
20-24	75	60	70	70
25-29	114	130	120	120
30-34	161	170	190	170
35-39	169	150	160	180
40-44	196	170	150	160
45-49	172	190	160	140
50-54	155	170	190	160
55-59	134	150	160	180
60-64	120	120	140	150
65-69	70	110	110	120
70-74	70	60	90	90
75-79	52	50	40	70
80-84	46	40	40	30
85+	45	50	50	40
Total	2,033	2,090	2,150	2,160
Females				
0-4	152	140	120	120
5-9	134	140	120	110
10-14	114	130	140	120
15-19	73	90	110	120
20-24	65	60	70	90
25-29	120	130	120	120
30-34	197	180	180	170
35-39	204	180	170	170
40-44	185	200	180	170
45-49	221	180	200	180
50-54	175	220	180	200
55-59	143	170	220	180
60-64	170	130	160	200
65-69	92	160	120	150
70-74	100	80	140	110
75-79	75	90	70	130
80-84	85	60	70	60
85+	110	120	120	120
Total	2,415	2,460	2,490	2,520
Total				
0-4	299	280	250	240
5-9	244	270	250	230
10-14	231	240	270	250
15-19	155	180	200	230
20-24	140	120	140	160
25-29	234	260	240	240
30-34	358	350	370	340
35-39	372	330	330	350
40-44	381	370	330	330
45-49	393	370	360	320
50-54	330	390	370	360
55-59	278	320	380	360
60-64	290	250	300	350
65-69	162	270	230	270
70-74	169	140	230	200
75-79	127	140	110	200
80-84	131	100	110	90
85+	155	170	170	160
Total	4,448	4,550	4,640	4,680
Median Age	42.5	43.3	44.1	44.5
Births	280	250	240	
Deaths	220	220	230	
Natural Increase	60	30	10	
Net Migration	60	60	50	
Change	120	90	60	

Differences between period Totals may not equal Change due to rounding.

Stratton Elementary

May 2015

	2010	2015	2020	2025
Males				
0-4	154	180	160	140
5-9	172	190	210	190
10-14	157	180	190	220
15-19	116	130	150	170
20-24	90	70	90	100
25-29	122	120	100	120
30-34	176	160	150	130
35-39	194	170	160	160
40-44	223	190	170	150
45-49	242	220	190	160
50-54	207	240	220	190
55-59	192	200	230	210
60-64	147	180	190	220
65-69	119	130	160	180
70-74	79	100	110	140
75-79	74	60	80	90
80-84	58	60	50	60
85+	36	50	60	50
Total	2,559	2,630	2,670	2,680
Females				
0-4	159	170	150	140
5-9	163	190	200	180
10-14	147	170	200	210
15-19	132	120	150	170
20-24	99	90	80	90
25-29	142	130	110	110
30-34	193	180	160	150
35-39	199	190	180	170
40-44	228	200	190	180
45-49	236	230	200	180
50-54	221	230	220	200
55-59	200	220	230	220
60-64	198	190	210	220
65-69	138	180	170	200
70-74	109	120	170	160
75-79	86	90	110	150
80-84	96	70	80	90
85+	66	100	110	120
Total	2,812	2,870	2,920	2,940
Total				
0-4	312	350	310	280
5-9	335	380	410	370
10-14	305	350	390	430
15-19	248	250	300	340
20-24	189	160	170	190
25-29	264	250	210	230
30-34	369	340	310	280
35-39	393	360	340	330
40-44	450	390	360	330
45-49	478	450	390	340
50-54	428	470	440	390
55-59	392	420	460	430
60-64	346	370	400	440
65-69	257	310	330	380
70-74	188	220	280	300
75-79	161	150	190	240
80-84	153	130	130	150
85+	102	150	170	170
Total	5,371	5,500	5,590	5,620
Median Age	43.0	44.0	44.9	45.4
Births	300	280	240	
Deaths	240	250	270	
Natural Increase	60	30	-30	
Net Migration	70	60	60	
Change	130	90	30	

Differences between period Totals may not equal Change due to rounding.



APPENDIX A

Thompson Elementary

May 2015

	2010	2015	2020	2025
Males				
0-4	285	280	260	230
5-9	194	250	260	240
10-14	160	200	260	270
15-19	179	130	170	210
20-24	153	190	140	180
25-29	289	290	340	290
30-34	391	380	380	430
35-39	382	340	320	330
40-44	304	330	290	270
45-49	295	290	310	280
50-54	253	290	290	300
55-59	222	250	280	280
60-64	180	210	230	260
65-69	105	150	180	200
70-74	84	90	130	150
75-79	94	70	70	110
80-84	62	70	50	60
85+	54	60	70	60
Total	3,687	3,870	4,030	4,150
Females				
0-4	267	270	250	220
5-9	202	230	250	230
10-14	159	210	240	250
15-19	144	130	180	190
20-24	185	150	140	190
25-29	366	320	300	290
30-34	429	460	420	400
35-39	411	380	410	370
40-44	353	360	330	350
45-49	312	340	340	320
50-54	317	310	340	340
55-59	273	310	300	330
60-64	199	270	290	290
65-69	143	170	240	270
70-74	141	130	150	210
75-79	142	130	120	140
80-84	110	120	110	100
85+	120	140	170	170
Total	4,273	4,430	4,580	4,660
Total				
0-4	552	550	510	450
5-9	396	480	510	470
10-14	319	410	500	520
15-19	323	260	350	400
20-24	338	340	280	370
25-29	656	610	640	580
30-34	820	840	800	830
35-39	793	720	730	700
40-44	658	690	620	620
45-49	607	630	650	600
50-54	570	600	630	640
55-59	495	560	580	610
60-64	378	480	520	550
65-69	248	320	420	470
70-74	225	220	280	360
75-79	237	200	190	250
80-84	172	190	160	160
85+	174	200	240	230
Total	7,960	8,300	8,610	8,810
Median Age	38.6	39.6	39.9	40.7
Births	560	530	470	
Deaths	310	330	350	
Natural Increase	250	200	120	
Net Migration	90	100	100	
Change	340	300	220	

Differences between period Totals may not equal Change due to rounding.

Arlington Public Schools: Total District Enrollment

	2010-11	2011-12	2012-13	2013-14	2014-15	2015-16	2016-17	2017-18	2018-19	2019-20	2020-21	2021-22	2022-23	2023-24	2024-25
PK	57	48	54	55	57	57	57	57	57	57	57	57	57	57	57
K	448	450	454	471	516	548	529	513	500	491	489	478	474	466	467
1	441	455	460	472	482	540	570	551	534	520	510	503	492	487	479
2	433	427	446	474	465	479	537	566	548	531	523	512	505	494	489
3	395	429	418	458	477	464	477	533	562	544	534	526	514	508	497
4	427	390	424	428	459	490	476	489	544	572	554	545	537	524	517
5	360	415	386	423	428	454	484	472	484	538	574	556	548	540	527
Total: PK-5	2561	2614	2642	2781	2884	3032	3130	3181	3229	3253	3241	3177	3127	3076	3033
6	344	349	374	352	397	398	422	450	439	450	495	528	512	504	497
7	347	331	328	385	341	389	390	414	441	430	437	480	512	497	489
8	360	346	326	317	369	334	381	382	406	432	417	424	466	497	482
Total: 6-8	1051	1026	1028	1054	1107	1121	1193	1246	1286	1312	1349	1432	1490	1498	1468
9	297	300	313	280	306	332	301	343	344	365	380	367	373	410	437
10	318	297	298	313	289	309	335	304	346	347	367	382	369	375	412
11	286	331	296	303	310	292	312	338	307	349	348	368	383	370	376
12	295	290	326	289	312	313	295	315	341	310	351	350	370	385	372
Total: 9-12	1196	1218	1233	1185	1217	1246	1243	1300	1338	1371	1446	1467	1495	1540	1597
Total: PK-12	4808	4858	4903	5020	5208	5399	5566	5727	5853	5936	6036	6076	6112	6114	6098
Total: PK-12	4808	4858	4903	5020	5208	5399	5566	5727	5853	5936	6036	6076	6112	6114	6098
Change		50	45	117	188	191	167	161	126	83	100	40	36	2	-16
%-Change		1.0%	0.9%	2.4%	3.7%	3.7%	3.1%	2.9%	2.2%	1.4%	1.7%	0.7%	0.6%	0.0%	-0.3%
Total: PK-5	2561	2614	2642	2781	2884	3032	3130	3181	3229	3253	3241	3177	3127	3076	3033
Change		53	28	139	103	148	98	51	48	24	-12	-64	-50	-51	-43
%-Change		2.1%	1.1%	5.3%	3.7%	5.1%	3.2%	1.6%	1.5%	0.7%	-0.4%	-2.0%	-1.6%	-1.6%	-1.4%
Total: 6-8	1051	1026	1028	1054	1107	1121	1193	1246	1286	1312	1349	1432	1490	1498	1468
Change		-25	2	26	53	14	72	53	40	26	37	83	58	8	-30
%-Change		-2.4%	0.2%	2.5%	5.0%	1.3%	6.4%	4.4%	3.2%	2.0%	2.8%	6.2%	4.1%	0.5%	-2.0%
Total: 9-12	1196	1218	1233	1185	1217	1246	1243	1300	1338	1371	1446	1467	1495	1540	1597
Change		22	15	-48	32	29	-3	57	38	33	75	21	28	45	57
%-Change		1.8%	1.2%	-3.9%	2.7%	2.4%	-0.2%	4.6%	2.9%	2.5%	5.5%	1.5%	1.9%	3.0%	3.7%

Brackett Elementary

	2010-11	2011-12	2012-13	2013-14	2014-15	2015-16	2016-17	2017-18	2018-19	2019-20	2020-21	2021-22	2022-23	2023-24	2024-25
K	84	84	64	82	97	101	97	94	91	89	88	85	84	83	82
1	67	90	89	73	83	102	105	101	98	95	93	91	88	87	86
2	80	70	87	88	68	81	100	103	99	96	94	92	90	87	86
3	64	73	74	89	92	69	82	101	104	100	98	96	94	92	89
4	76	64	71	77	88	93	70	83	102	105	102	100	98	96	94
5	73	72	64	72	69	85	90	68	81	99	103	100	98	96	94
Total K-5	444	453	449	481	497	531	544	550	575	584	578	564	552	541	531
Total K-5	444	453	449	481	497	531	544	550	575	584	578	564	552	541	531
Change		9	-4	32	16	34	13	6	25	9	-6	-14	-12	-11	-10
% Change		2.0%	-0.9%	7.1%	3.3%	6.8%	2.4%	1.1%	4.5%	1.6%	-1.0%	-2.4%	-2.1%	-2.0%	-1.8%



APPENDIX A

Bishop Elementary

	2010-11	2011-12	2012-13	2013-14	2014-15	2015-16	2016-17	2017-18	2018-19	2019-20	2020-21	2021-22	2022-23	2023-24	2024-25
K	68	70	58	65	68	70	68	65	63	62	65	65	66	66	67
1	55	68	76	64	72	71	75	73	70	68	67	68	68	69	69
2	72	54	65	76	68	73	72	76	74	71	70	69	70	70	71
3	64	73	59	71	76	71	76	75	79	77	75	74	73	74	74
4	60	64	76	59	72	77	72	77	76	80	79	77	76	75	76
5	44	57	66	77	59	71	76	71	76	75	81	80	79	78	77
Total K-5	363	386	400	412	415	433	439	437	438	433	437	433	432	432	434
Total K-5	363	386	400	412	415	433	439	437	438	433	437	433	432	432	434
Change		23	14	12	3	18	6	-2	1	-5	4	-4	-1	0	2
% Change		6.3%	3.6%	3.0%	0.7%	4.3%	1.4%	-0.5%	0.2%	-1.1%	0.9%	-0.9%	-0.2%	0.0%	0.5%

Dallin Elementary

	2010-11	2011-12	2012-13	2013-14	2014-15	2015-16	2016-17	2017-18	2018-19	2019-20	2020-21	2021-22	2022-23	2023-24	2024-25
K	86	74	67	82	74	78	76	74	74	73	73	72	71	70	68
1	74	94	75	68	78	76	80	78	76	75	74	74	73	72	71
2	70	73	96	77	66	79	77	81	79	77	77	75	75	74	73
3	63	70	71	94	76	65	77	75	79	77	76	76	74	74	73
4	67	62	70	76	89	77	66	78	76	80	79	78	78	75	75
5	64	63	64	70	73	87	75	65	76	74	79	78	77	77	74
Total K-5	424	436	443	467	456	462	451	451	460	456	458	453	448	442	434
Total K-5	424	436	443	467	456	462	451	451	460	456	458	453	448	442	434
Change		12	7	24	-11	6	-11	0	9	-4	2	-5	-5	-6	-8
% Change		2.8%	1.6%	5.4%	-2.4%	1.3%	-2.4%	0.0%	2.0%	-0.9%	0.4%	-1.1%	-1.1%	-1.3%	-1.8%

Hardy Elementary

	2010-11	2011-12	2012-13	2013-14	2014-15	2015-16	2016-17	2017-18	2018-19	2019-20	2020-21	2021-22	2022-23	2023-24	2024-25
K	42	64	67	65	82	89	85	83	81	80	80	78	77	76	73
1	65	46	62	67	69	86	93	89	86	84	83	82	80	79	78
2	57	65	47	71	68	70	87	94	90	87	86	85	84	82	81
3	69	58	59	49	68	67	69	85	92	88	86	85	84	83	81
4	56	64	55	58	46	65	64	66	81	87	84	83	82	81	80
5	40	56	60	53	59	45	63	62	64	79	85	82	81	80	79
Total K-5	329	353	350	363	392	422	461	479	494	505	504	495	488	481	472
Total K-5	329	353	350	363	392	422	461	479	494	505	504	495	488	481	472
Change		24	-3	13	29	30	39	18	15	11	-1	-9	-7	-7	-9
% Change		7.3%	-0.8%	3.7%	8.0%	7.7%	9.2%	3.9%	3.1%	2.2%	-0.2%	-1.8%	-1.4%	-1.4%	-1.9%

Peirce Elementary

	2010-11	2011-12	2012-13	2013-14	2014-15	2015-16	2016-17	2017-18	2018-19	2019-20	2020-21	2021-22	2022-23	2023-24	2024-25
K	44	50	51	44	47	44	43	42	41	40	40	39	39	38	40
1	50	46	52	46	44	46	45	44	43	42	41	41	40	40	39
2	47	45	44	47	44	41	43	42	41	40	40	39	39	38	38
3	40	53	43	41	47	42	39	41	40	39	39	39	38	38	37
4	47	39	52	42	43	56	50	47	49	48	41	41	41	40	40
5	38	50	35	50	42	42	55	49	46	48	49	42	42	42	41
Total K-5	266	283	277	270	267	271	275	265	260	257	250	241	239	236	235
Total K-5 Change	266	283	277	270	267	271	275	265	260	257	250	241	239	236	235
% Change		17	-6	-7	-3	4	4	-10	-5	-3	-7	-9	-2	-3	-1
		6.4%	-2.1%	-2.5%	-1.1%	1.5%	1.5%	-3.6%	-1.9%	-1.2%	-2.7%	-3.6%	-0.8%	-1.3%	-0.4%

Stratton Elementary

	2010-11	2011-12	2012-13	2013-14	2014-15	2015-16	2016-17	2017-18	2018-19	2019-20	2020-21	2021-22	2022-23	2023-24	2024-25
K	59	52	62	66	67	74	72	70	68	67	66	65	64	62	64
1	69	53	57	63	68	70	77	75	73	71	70	68	67	66	64
2	62	65	56	66	69	71	74	81	79	77	75	74	72	71	70
3	43	56	66	61	68	70	72	75	82	80	79	77	75	73	72
4	58	49	54	67	66	71	73	75	78	85	84	83	81	79	77
5	52	59	48	52	70	67	72	74	76	79	87	86	85	83	81
Total K-5	343	334	343	375	408	423	440	450	456	459	461	453	444	434	428
Total K-5 Change	343	334	343	375	408	423	440	450	456	459	461	453	444	434	428
% Change		-9	9	32	33	15	17	10	6	3	2	-8	-9	-10	-6
		-2.6%	2.7%	9.3%	8.8%	3.7%	4.0%	2.3%	1.3%	0.7%	0.4%	-1.7%	-2.0%	-2.3%	-1.4%

Thompson Elementary

	2010-11	2011-12	2012-13	2013-14	2014-15	2015-16	2016-17	2017-18	2018-19	2019-20	2020-21	2021-22	2022-23	2023-24	2024-25
K	65	56	85	67	81	92	88	85	82	80	77	74	73	71	73
1	61	58	49	91	68	89	95	91	88	85	82	79	76	74	72
2	45	55	51	49	82	64	84	89	86	83	81	78	75	72	70
3	52	46	46	53	50	80	62	81	86	83	81	79	76	74	71
4	63	48	46	49	55	51	81	63	82	87	85	83	81	78	75
5	49	58	49	49	56	57	53	83	65	84	90	88	86	84	81
Total K-5	335	321	326	358	392	433	463	492	489	502	496	481	467	453	442
Total K-5 Change	335	321	326	358	392	433	463	492	489	502	496	481	467	453	442
% Change		-14	5	32	34	41	30	29	-3	13	-6	-15	-14	-14	-11
		-4.2%	1.6%	9.8%	9.5%	10.5%	6.9%	6.3%	-0.6%	2.7%	-1.2%	-3.0%	-2.9%	-3.0%	-2.4%



APPENDIX A

Ottoson Middle School

	2010-11	2011-12	2012-13	2013-14	2014-15	2015-16	2016-17	2017-18	2018-19	2019-20	2020-21	2021-22	2022-23	2023-24	2024-25
6	344	349	374	352	397	398	422	450	439	450	495	528	512	504	497
7	347	331	328	385	341	389	390	414	441	430	437	480	512	497	489
8	360	346	326	317	369	334	381	382	406	432	417	424	466	497	482
Total: 6-8	1051	1026	1028	1054	1107	1121	1193	1246	1286	1312	1349	1432	1490	1498	1468
Total: 6-8	1051	1026	1028	1054	1107	1121	1193	1246	1286	1312	1349	1432	1490	1498	1468
Change		-25	2	26	53	14	72	53	40	26	37	83	58	8	-30
% Change		-2.4%	0.2%	2.5%	5.0%	1.3%	6.4%	4.4%	3.2%	2.0%	2.8%	6.2%	4.1%	0.5%	-2.0%

Arlington High School

	2010-11	2011-12	2012-13	2013-14	2014-15	2015-16	2016-17	2017-18	2018-19	2019-20	2020-21	2021-22	2022-23	2023-24	2024-25
9	297	300	313	280	306	332	301	343	344	365	380	367	373	410	437
10	318	297	298	313	289	309	335	304	346	347	367	382	369	375	412
11	286	331	296	303	310	292	312	338	307	349	348	368	383	370	376
12	295	290	326	289	312	313	295	315	341	310	351	350	370	385	372
Total: 9-12	1196	1218	1233	1185	1217	1246	1243	1300	1338	1371	1446	1467	1495	1540	1597
Total: 9-12	1196	1218	1233	1185	1217	1246	1243	1300	1338	1371	1446	1467	1495	1540	1597
Change		22	15	-48	32	29	-3	57	38	33	75	21	28	45	57
% Change		1.8%	1.2%	-3.9%	2.7%	2.4%	-0.2%	4.6%	2.9%	2.5%	5.5%	1.5%	1.9%	3.0%	3.7%

ARLINGTON PUBLIC SCHOOLS - APPENDIX B												
ENROLLMENT FORECASTS:												
SCHOOL	2014-15	5-YEAR CHANGE	2019-20	% CHANGE	5-YEAR CHANGE	2024-25	% CHANGE	10-YEAR CHANGE	Projection/ Growth	Current Capacity YR15/16 (see below)	Expansion Potential	
1 BISHOP	415	18	433	1.04	1	434	1.05	19	LOW	OK	GOOD	
2 BRACKETT	497	87	584	1.18	-53	531	1.07	34	HIGH	@ CAPACITY	FAIR	
3 DALLIN	456	0	456	1.00	-22	434	0.95	-22	LOW	@ CAPACITY	FAIR	
4 HARDY	392	113	505	1.29	-33	472	1.20	80	HIGH	OK	GOOD	
5 PEIRCE	267	-10	257	0.96	-22	235	0.88	-32	LOW	OK	POOR	
6 STRATTON	408	51	459	1.13	-31	428	1.05	20	LOW	OK	GOOD	
7 THOMPSON	392	110	502	1.28	-60	442	1.13	50	HIGH	@ CAPACITY	GOOD	
TOTAL K-5	2827	369	3196	1.13	-220	2976	1.05	149				
M OTTOSON MIDDLE	1107	205	1312	1.19	156	1468	1.33	361	HIGH	@ CAPACITY	FAIR	
H ARLINGTON HIGH	1217	154	1371	1.13	226	1597	1.31	380	HIGH		FAIR	
TOTAL SYSTEM-WIDE								1039				

ARLINGTON PUBLIC SCHOOLS ENROLLMENT FORECASTS

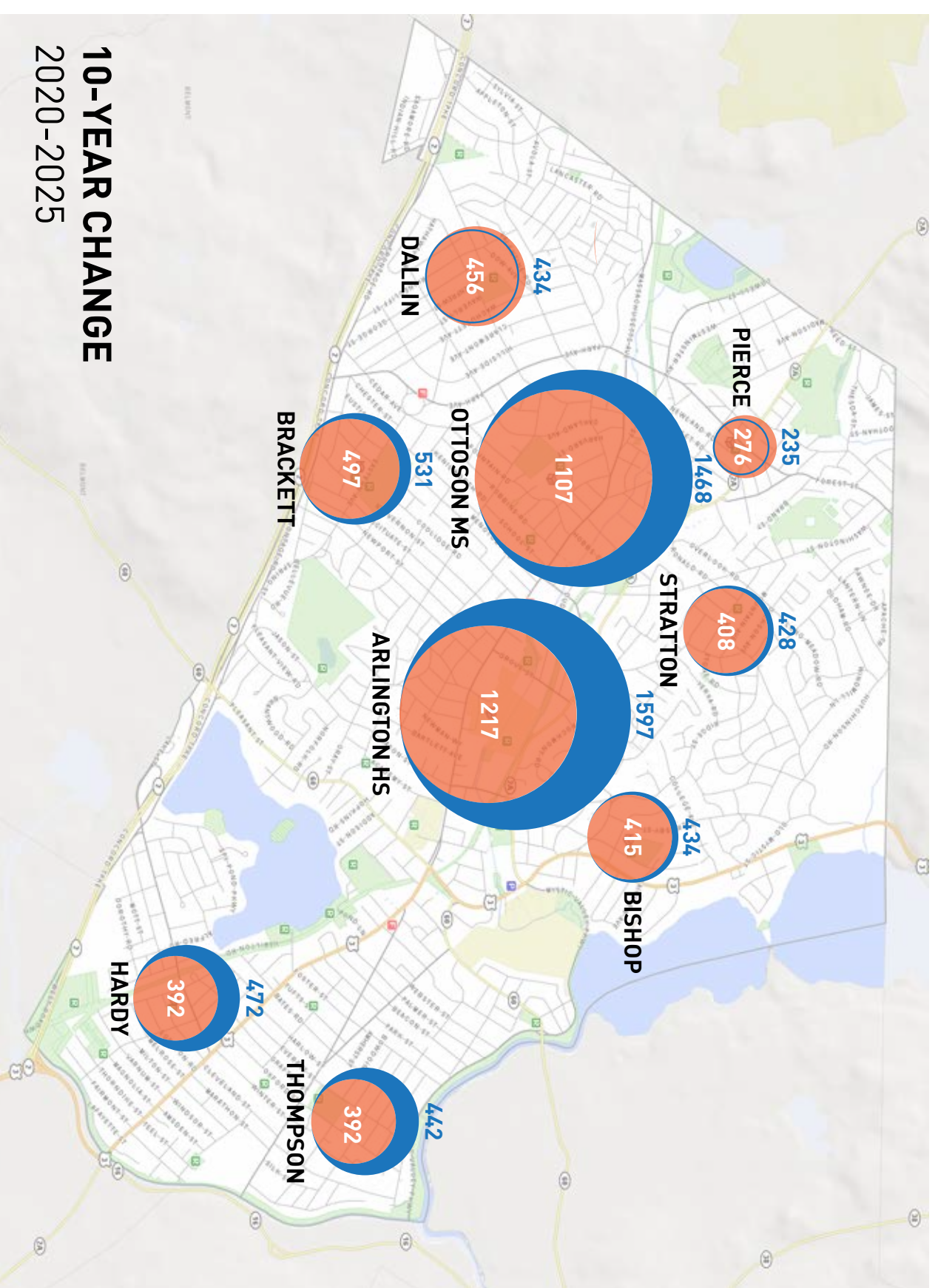
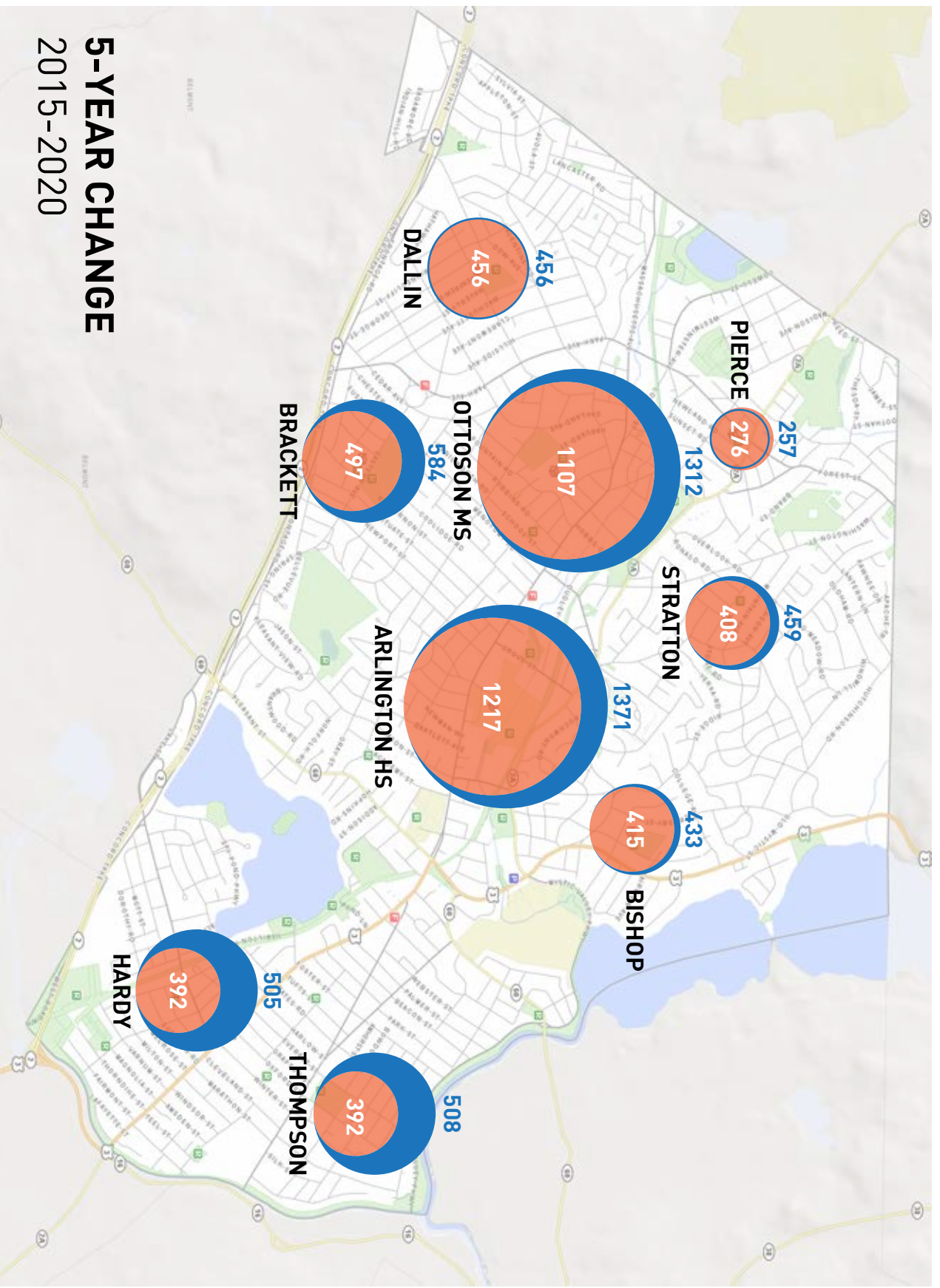
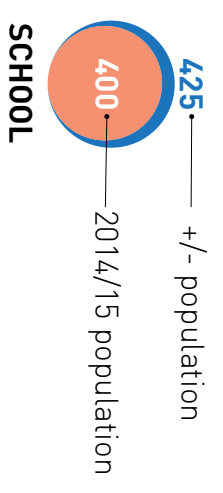

ARLINGTON PUBLIC SCHOOLS - APPENDIX C																		
CAPACITY/USE:																		
SCHOOL	PROGRAM SPACE USE AS OF SCHOOL YEAR 2014-15:						Specialists*	Notes:	SF**	ACRES**	25 /CR =	Forecast 2019-20		Diff.	22 /CR =	Forecast 2019-20		Diff.
1 BISHOP	3 Ks	15 CRs	Art	Music	Computer	-	1 Specialist		57,762	2.081	450	433	-17	396	433	37		
2 BRACKETT	3 Ks	20 CRs ^a	Art	Music	-	ASP ^a	2 Specialists	(^a note: 1 CR as K, 2 CR as SLC, 1CR as ASP)	72,000	3.106	575	584	9	506	584	78		
3 DALLIN	4 Ks	15 CRs	Art	Music	-	-	5 Specialists		69,136	1.365	475	456	-19	418	456	38		
4 HARDY	4 Ks	14 CRs	Art	Music	Computer	2 ASP	3 Specialists + Teacher's Wkrm		55,021	2.540	450	505	55	396	505	109		
5 PEIRCE	3 Ks ^b	12 CRs	Art	Music	Computer	ASP	1 Specialist	(^b note: 1K as Daycare)	39,000	2.522	375	257	-118	330	257	-73		
6 STRATTON	3 Ks	15 CRs	Art	Music	Computer	2 ASP	8 Specialists		68,200	3.838	450	459	9	396	459	63		
7 THOMPSON	4 Ks	15 CRs	Art	Music ^c	-	ASP ^c	3 Specialists	(^c note: Music on Stage; ASP in 1 K)	57,000	3.116	475	502	27	418	502	84		
M OTTOSON MIDDLE	16-6th;13-7th;13-8th						2 Art	4 Music	2 Comp,3 Tech Labs,6 Lang,3 FACS,4 SPED	226,911	7.149							
H ARLINGTON HIGH	46 CRs, 11 Sci, 4 Art, 1 Music, 4 Shops, ~2 Consumer Sci, + LABB, + Preschool									394,426	7.835							
									** Town of Arlington GIS		3250	3196	-54	2860	3196	336		
									* Specialists include the wide range of programs other than those identified on the chart and the Gym/Café/Library, and may include Supported Learning Programs.									
									Of note, the quantity indicates a single space or multiple spaces that if combined would accommodate a general classroom.									
									Any displaced program would require space found elsewhere.									

District:	Arlington
School Name:	Bishop Elementary School
Address:	25 Columbia Road Arlington, MA 02474
School Hours:	
In-session Contact:	Stephen Carne (781) 316-3791
Off-Hours Contact:	
Approach Hazards:	Primary; Arlington High School; Secondary; Stratton School
Notes:	

BISHOP

1st Floor















Side C

1st Floor

Side B

Side D

Legend

-  Single Door
-  Double Door
-  Window
-  Stairs
-  Ramp
-  Elevator
-  Fire Extinguisher
-  Gas Shut-Off
-  Electrical Shut-Off
-  Water Shut-Off
-  Chair Lift
-  Sprinkler Shutoff
-  Generator
-  Camera
-  Fire Standpipe



Side A



District:	Arlington
School Name:	Bishop Elementary School
Address:	25 Columbia Road Arlington, MA 02474
School Hours:	
In-session Contact:	Stephen Carme (781) 316-3791
Off-Hours Contact:	
Approach Hazards:	Primary; Arlington High School; Secondary; Stratton School
Notes:	

BISHOP

1st Floor

Side C

2nd Floor

Side B

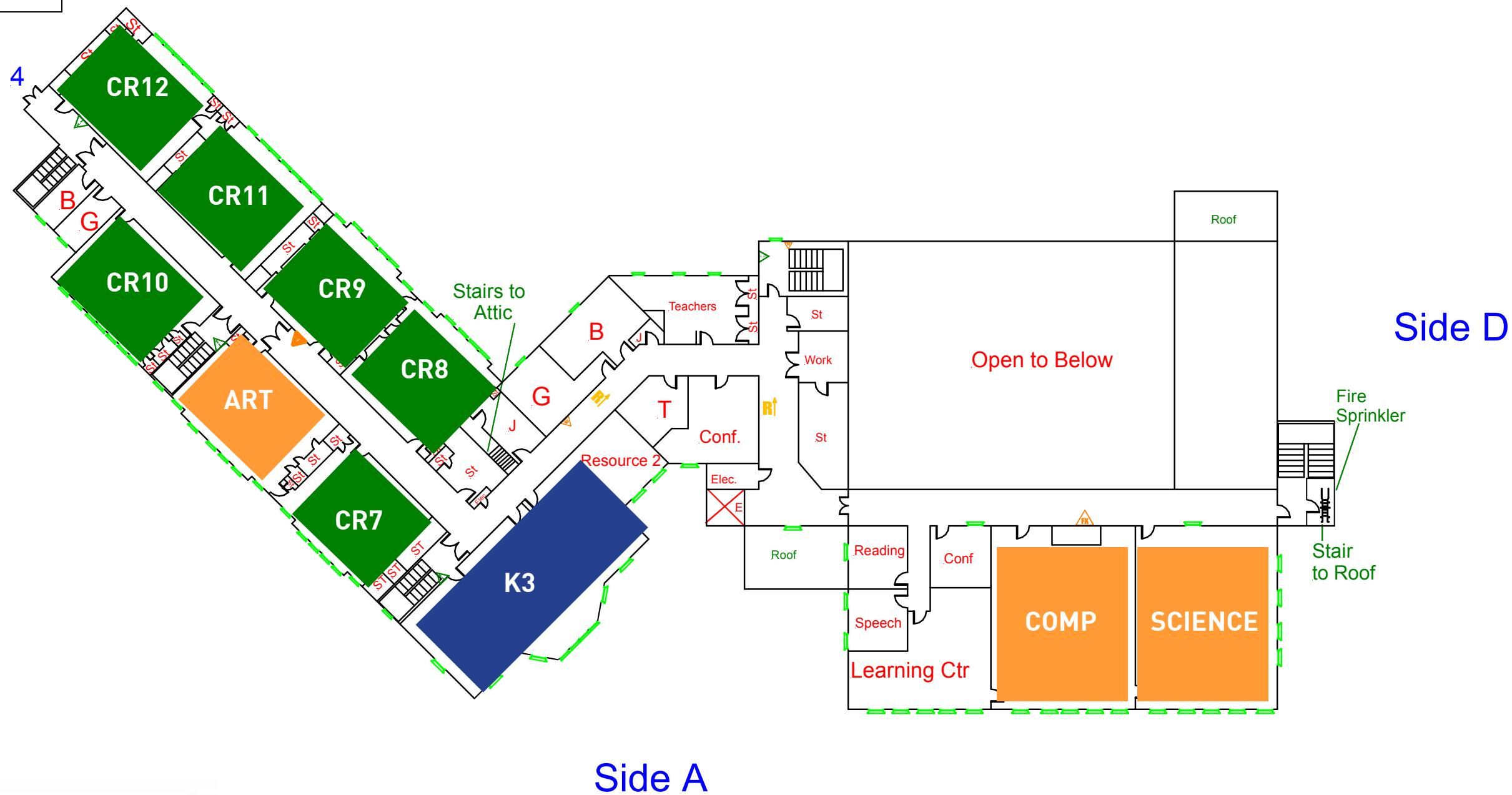

Side D

Side A

Legend

- Single Door
- Double Door
- Window
- Stairs
- Ramp
- Elevator
- Fire Extinguisher
- Gas Shut-Off
- Electrical Shut-Off
- Water Shut-Off
- Chair Lift
- Sprinkler Shutoff
- Generator
- Camera
- Fire Standpipe



With funding and support from...



District:	Arlington
School Name:	Bishop Elementary School
Address:	25 Columbia Road Arlington, MA 02474
School Hours:	
In-session Contact:	Stephen Carme (781) 316-3791
Off-Hours Contact:	
Approach Hazards:	Primary; Arlington High School; Secondary; Stratton School
Notes:	

BISHOP

Ground Floor















Side C

Ground Floor

Side B

Side D

Legend

-  Single Door
-  Double Door
-  Window
-  Stairs
-  Ramp
-  Elevator
-  Fire Extinguisher
-  Gas Shut-Off
-  Electrical Shut-Off
-  Water Shut-Off
-  Chair Lift
-  Sprinkler Shutoff
-  Generator
-  Camera
-  Fire Standpipe

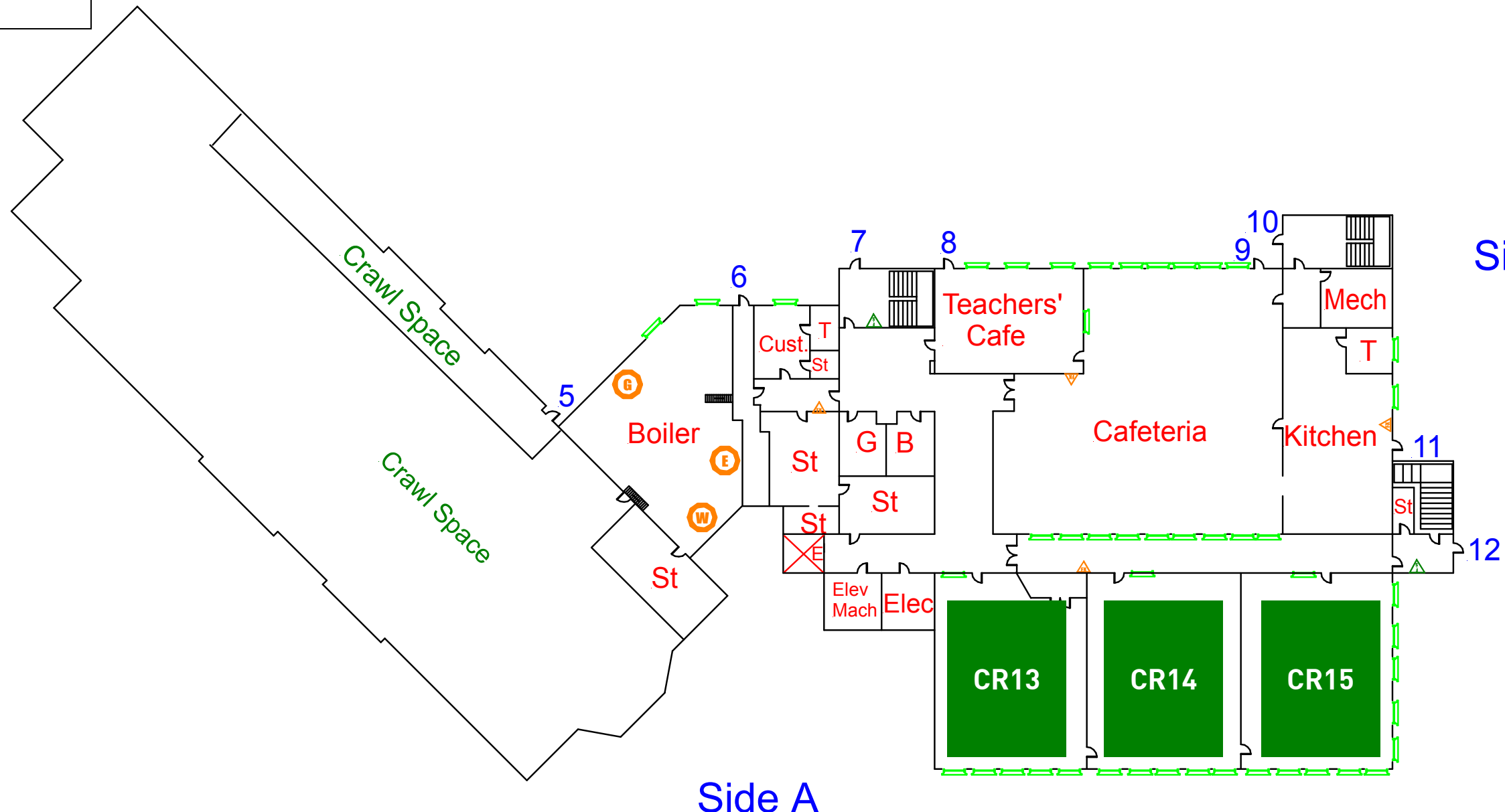

Side A

District:	Arlington
School Name:	Brackett Elementary School
Address:	66 Eastern Avenue Arlington, MA 02474
School Hours:	
In-session Contact:	Stephanie Zerchykov (781) 316-3702
Off-Hours Contact:	
Approach Hazards:	
Notes:	

Side C

BRACKETT















1st Floor

1st Floor

Side B

Side D

Legend

-  Single Door
-  Double Door
-  Window
-  Stairs
-  Ramp
-  Elevator
-  Fire Extinguisher
-  Gas Shut-Off
-  Electrical Shut-Off
-  Water Shut-Off
-  Chair Lift
-  Sprinkler Shutoff
-  Generator
-  Camera
-  Fire Standpipe

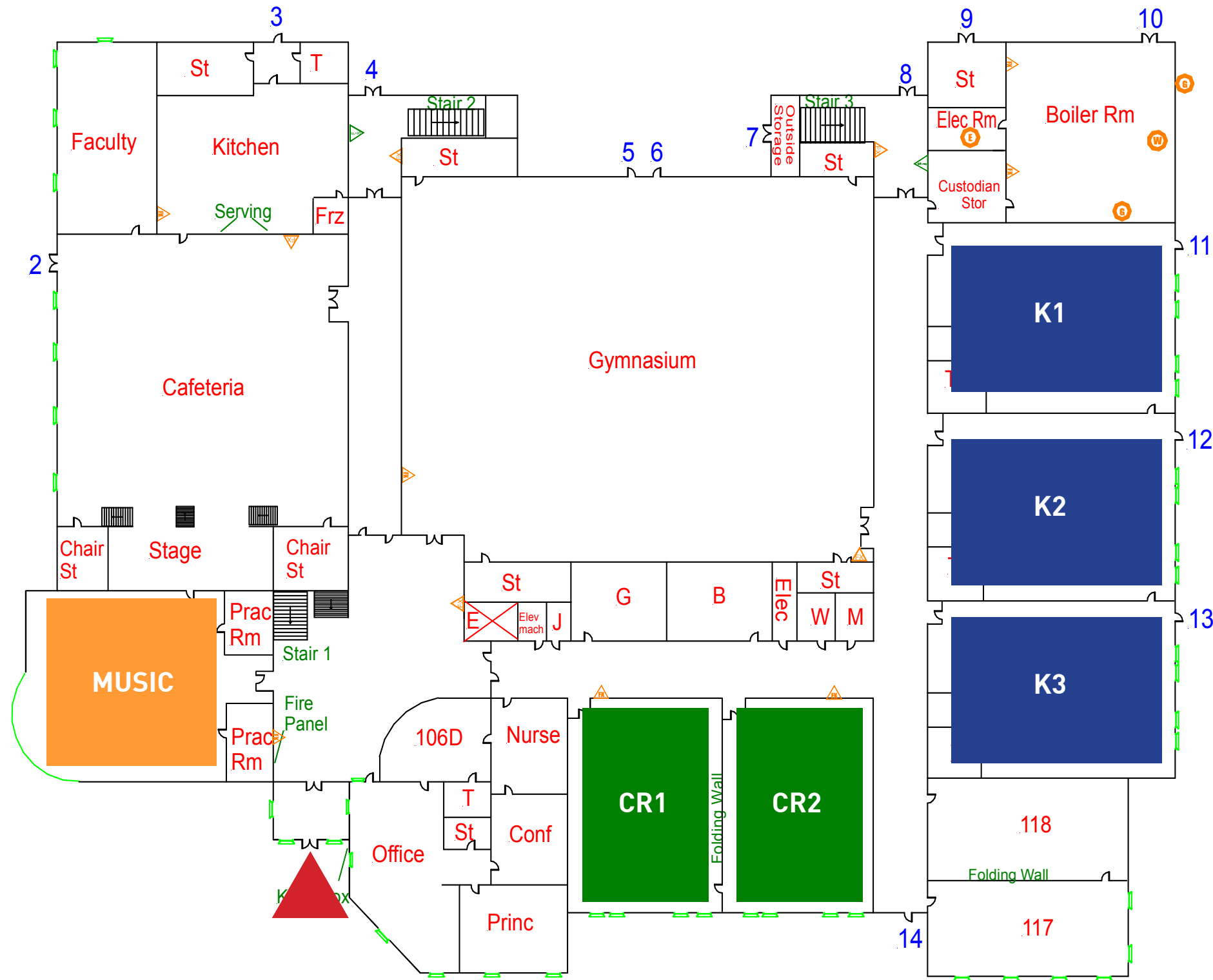

Side A



With funding and support from



NORTHEAST HOMELAND SECURITY REGIONAL ADVISORY COUNCIL



Metropolitan Area Planning Council



District:	Arlington
School Name:	Brackett Elementary School
Address:	66 Eastern Avenue Arlington, MA 02474
School Hours:	
In-session Contact:	Stephanie Zerchykov (781) 316-3702
Off-Hours Contact:	
Approach Hazards:	
Notes:	

BRACKETT

2nd Floor

2nd Floor

Side B

Side C

Side D

Side A

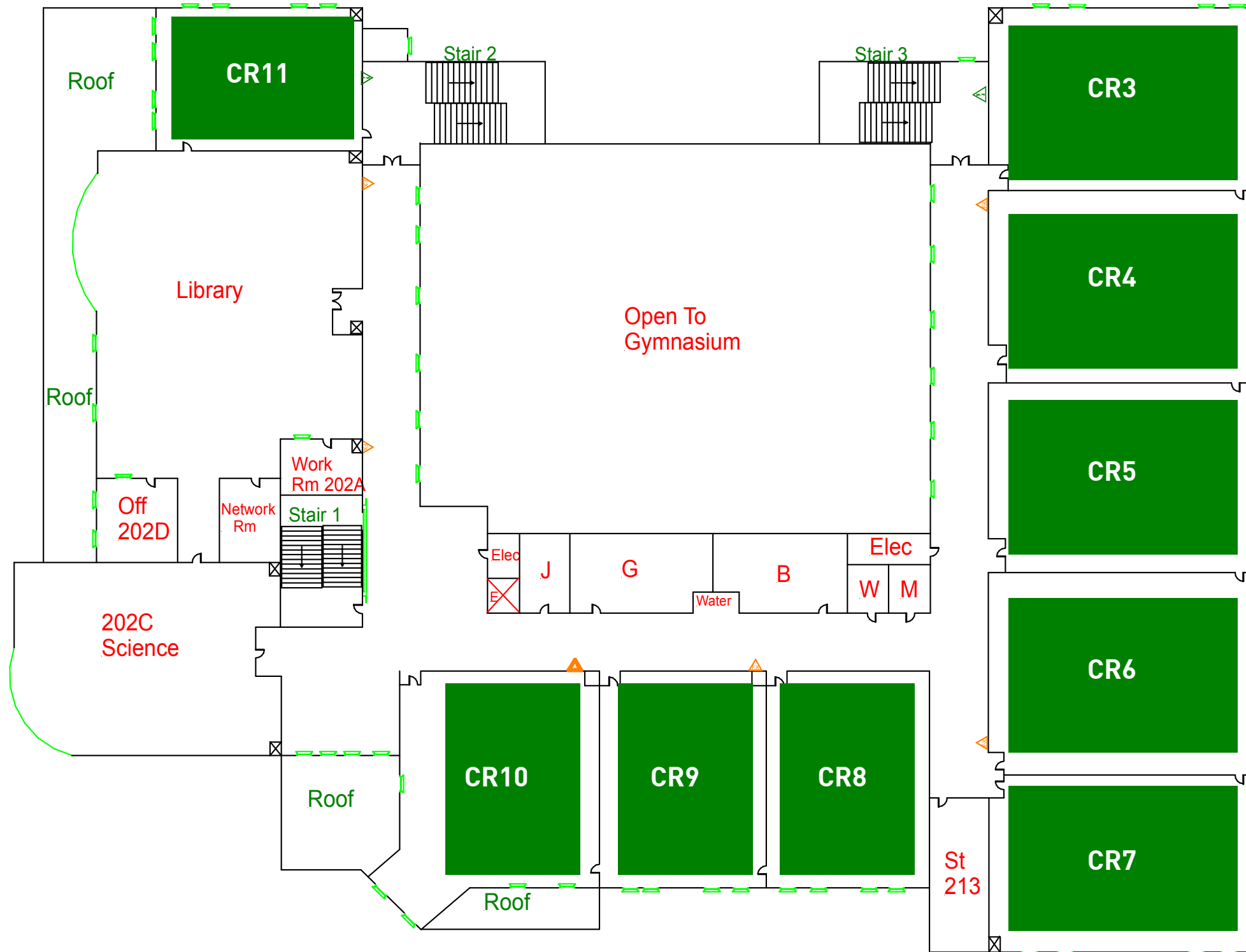

Legend

- Single Door
- Double Door
- Window
- Stairs
- Ramp
- Elevator
- Fire Extinguisher
- Gas Shut-Off
- Electrical Shut-Off
- Water Shut-Off
- Chair Lift
- Sprinkler Shutoff
- Generator
- Camera
- Fire Standpipe



District:	Arlington
School Name:	Brackett Elementary School
Address:	66 Eastern Avenue Arlington, MA 02474
School Hours:	
In-session Contact:	Stephanie Zerchykov (781) 316-3702
Off-Hours Contact:	
Approach Hazards:	
Notes:	

BRACKETT

3rd Floor

Side C

3rd Floor

Side B

Side D

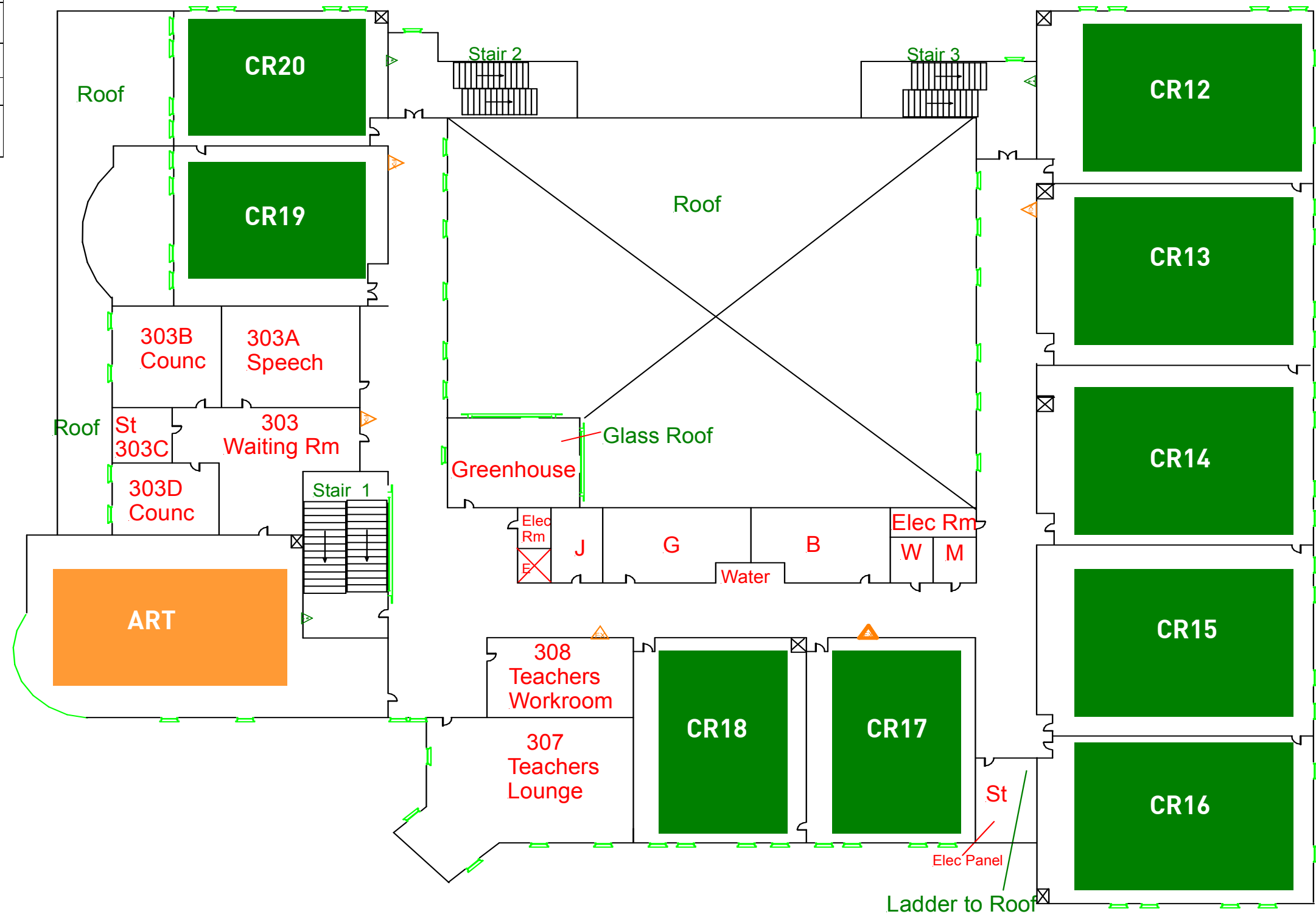

Legend

- Single Door
- Double Door
- Window
- Stairs
- Ramp
- Elevator
- Fire Extinguisher
- Gas Shut-Off
- Electrical Shut-Off
- Water Shut-Off
- Chair Lift
- Sprinkler Shutoff
- Generator
- Camera
- Fire Standpipe

Side A



District:	Arlington
School Name:	Dallin Elementary School
Address:	185 Florence Avenue Arlington, MA 02474
School Hours:	
In-session Contact:	Wallis Raemer (781) 316-3730
Off-Hours Contact:	
Approach Hazards:	None; Residential Neighborhood; Ball Field Side D; Can drive around school
Notes:	

DALLIN

1st Floor

1st Floor

Side B

Side C

Side D

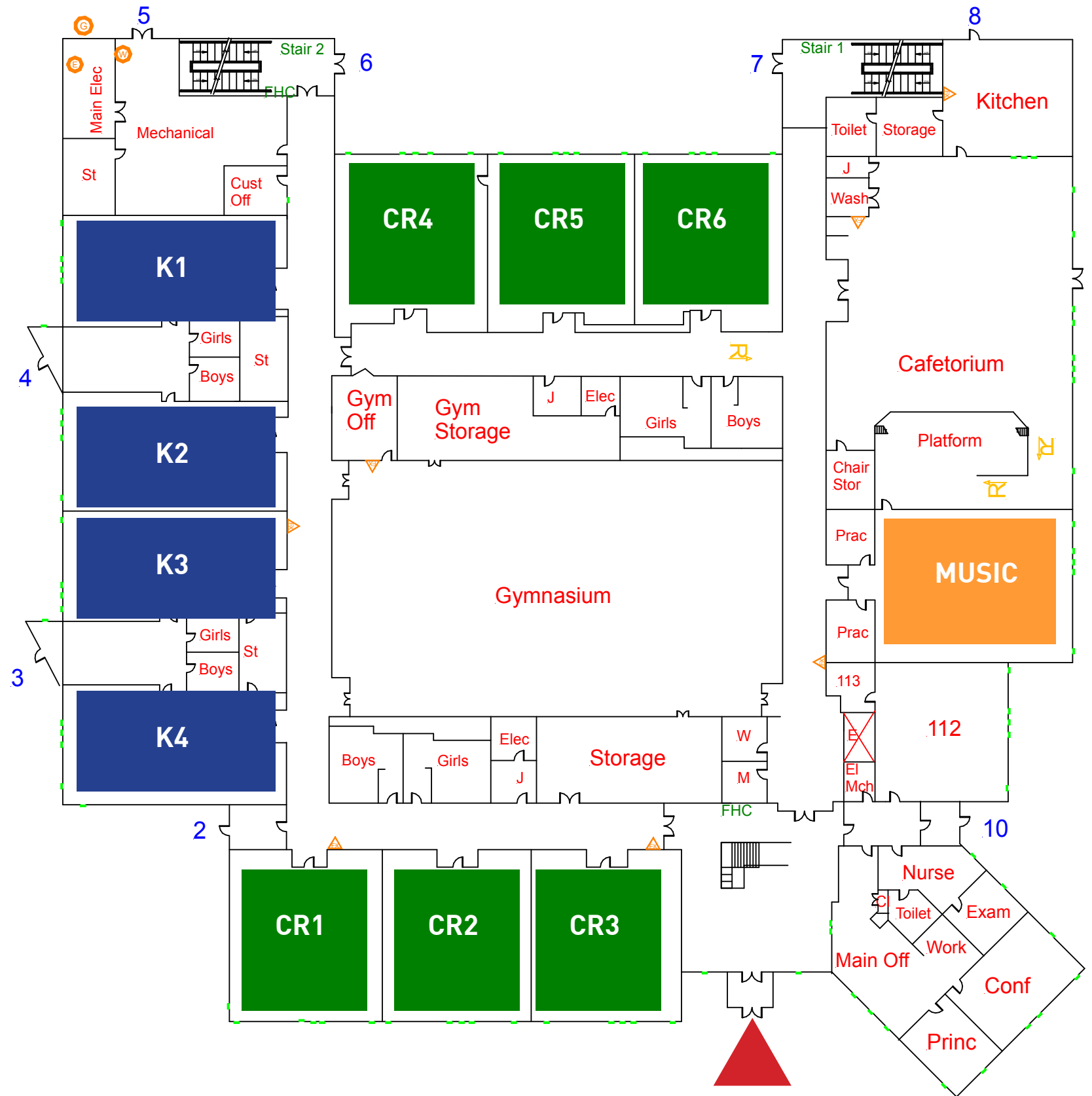

Legend

- Single Door
- Double Door
- Window
- Stairs
- Ramp
- Elevator
- Fire Extinguisher
- Gas Shut-Off
- Electrical Shut-Off
- Water Shut-Off
- Chair Lift
- Sprinkler Shutoff
- Generator
- Camera
- Fire Standpipe



Side A

District:	Arlington
School Name:	Dallin Elementary School
Address:	185 Florence Avenue Arlington, MA 02474
School Hours:	
In-session Contact:	Wallis Raemer (781) 316-3730
Off-Hours Contact:	
Approach Hazards:	None; Residential Neighborhood; Ball Field Side D; Can drive around school
Notes:	

DALLIN

2nd Floor















2nd Floor

Side B

Side C

Side D

Legend

-  Single Door
-  Double Door
-  Window
-  Stairs
-  Ramp
-  Elevator
-  Fire Extinguisher
-  Gas Shut-Off
-  Electrical Shut-Off
-  Water Shut-Off
-  Chair Lift
-  Sprinkler Shutoff
-  Generator
-  Camera
-  Fire Standpipe

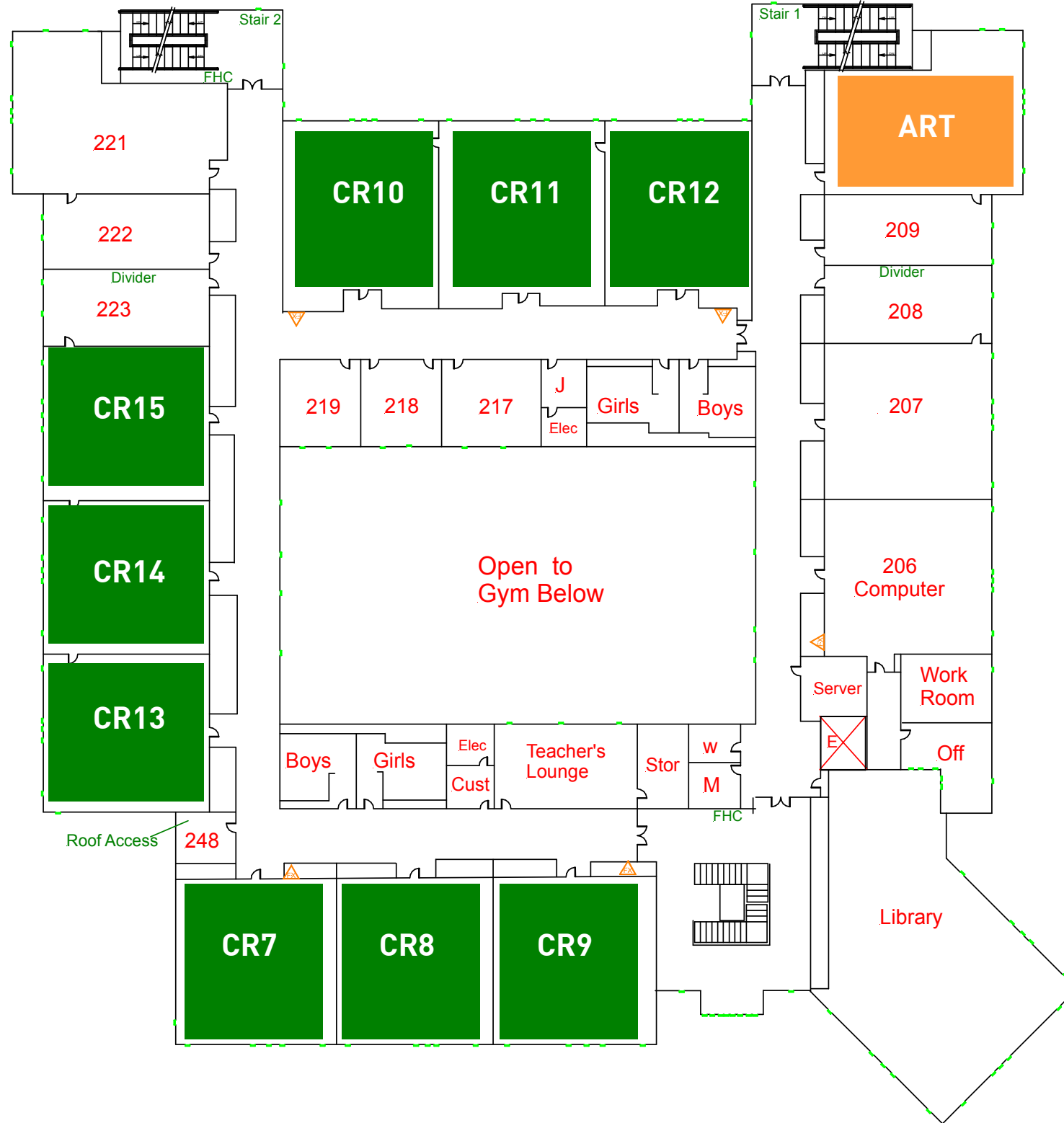

Side A



District:	Arlington
School Name:	Hardy Elementary School
Address:	52 Lake Street Arlington, MA 02474
School Hours:	
In-session Contact:	Deborah D'Amico (781) 316-3782
Off-Hours Contact:	
Approach Hazards:	
Notes:	

HARDY

Ground Floor

Ground Floor Plan

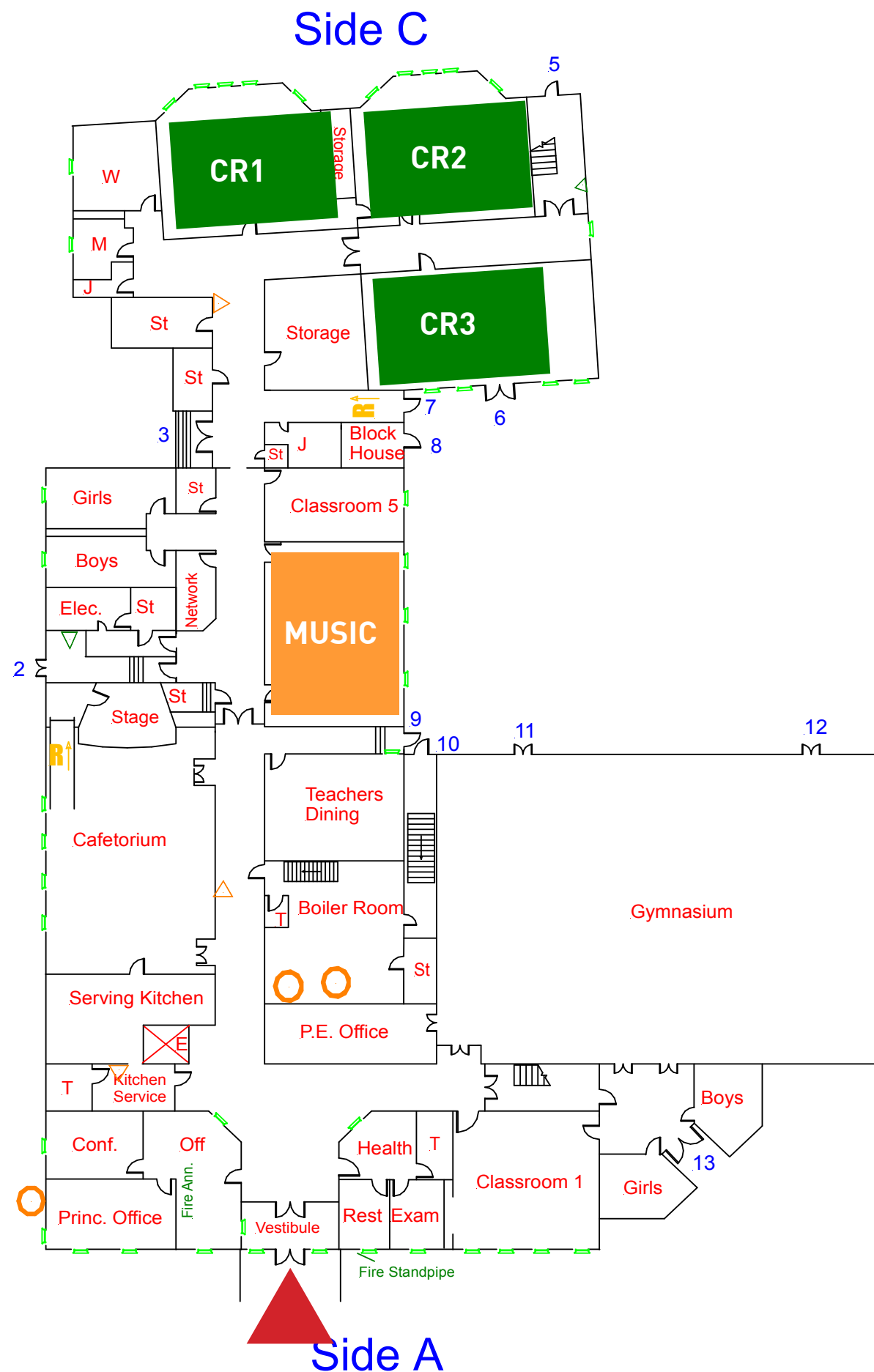

Side B

Side D

Side C

Side A

Legend

- Single Door
- Double Door
- Window
- Stairs
- Ramp
- Elevator
- Fire Extinguisher
- Gas Shut-Off
- Electrical Shut-Off
- Water Shut-Off
- Chair Lift
- Sprinkler Shutoff
- Generator
- Camera
- Fire Standpipe



With Funding and Support from:



Metropolitan Area Planning Council

District:	Arlington
School Name:	Hardy Elementary School
Address:	52 Lake Street Arlington, MA 02474
School Hours:	
In-session Contact:	Deborah D'Amico (781) 316-3782
Off-Hours Contact:	
Approach Hazards:	
Notes:	

HARDY

1st Floor















1st Floor

Side B

Side C

Side D

Legend

-  Single Door
-  Double Door
-  Window
-  Stairs
-  Ramp
-  Elevator
-  Fire Extinguisher
-  Gas Shut-Off
-  Electrical Shut-Off
-  Water Shut-Off
-  Chair Lift
-  Sprinkler Shutoff
-  Generator
-  Camera
-  Fire Standpipe

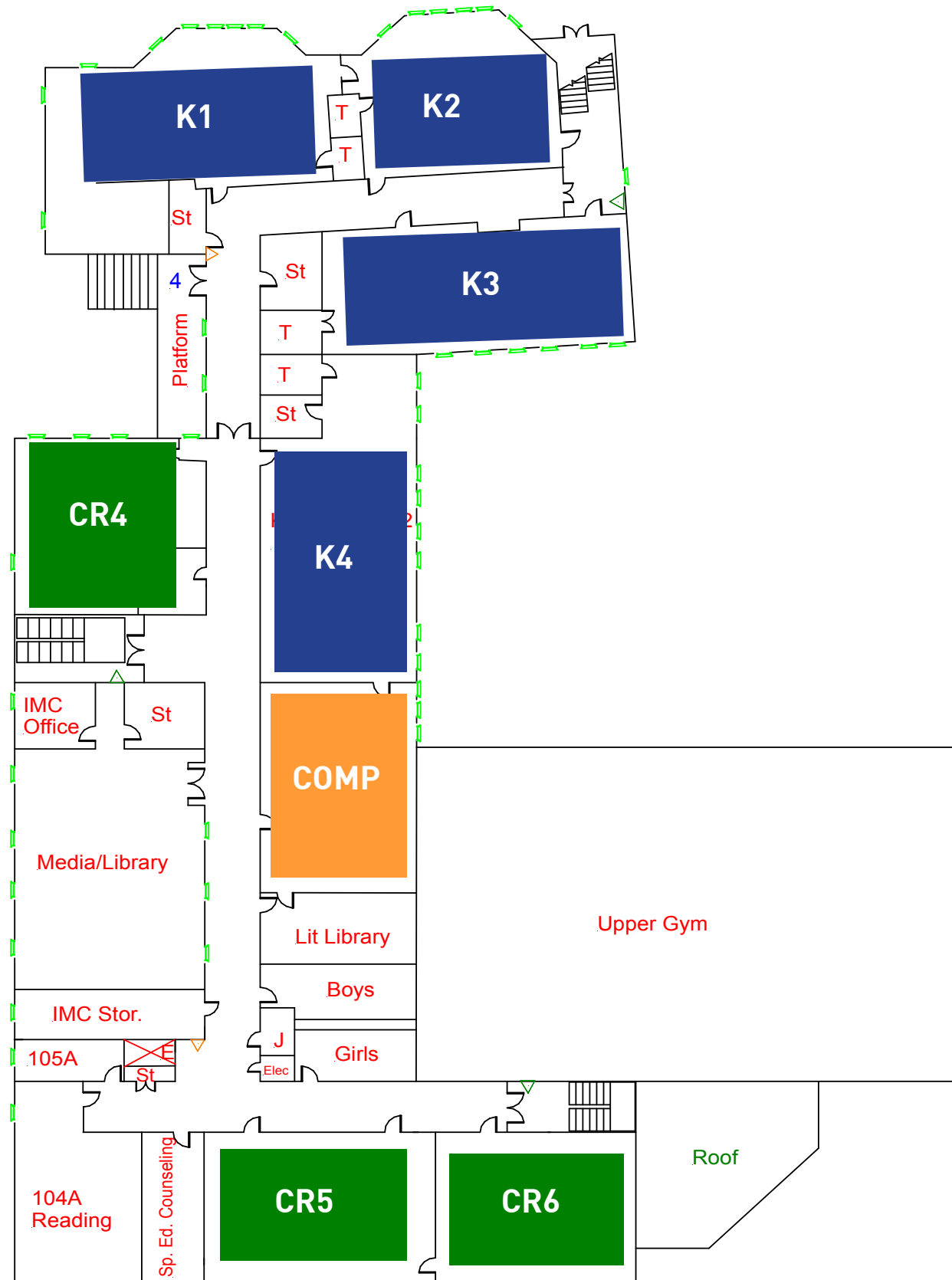

Side A



NORTHEAST HOMELAND SECURITY
REGIONAL ADVISORY COUNCIL

















District:	Arlington
School Name:	Hardy Elementary School
Address:	52 Lake Street Arlington, MA 02474
School Hours:	
In-session Contact:	Deborah D'Amico (781) 316-3782
Off-Hours Contact:	
Approach Hazards:	
Notes:	

HARDY

2nd Floor

2nd Floor

Legend

-  Single Door
-  Double Door
-  Window
-  Stairs
-  Ramp
-  Elevator
-  Fire Extinguisher
-  Gas Shut-Off
-  Electrical Shut-Off
-  Water Shut-Off
-  Chair Lift
-  Sprinkler Shutoff
-  Generator
-  Camera
-  Fire Standpipe

Side B

Side C

Side D

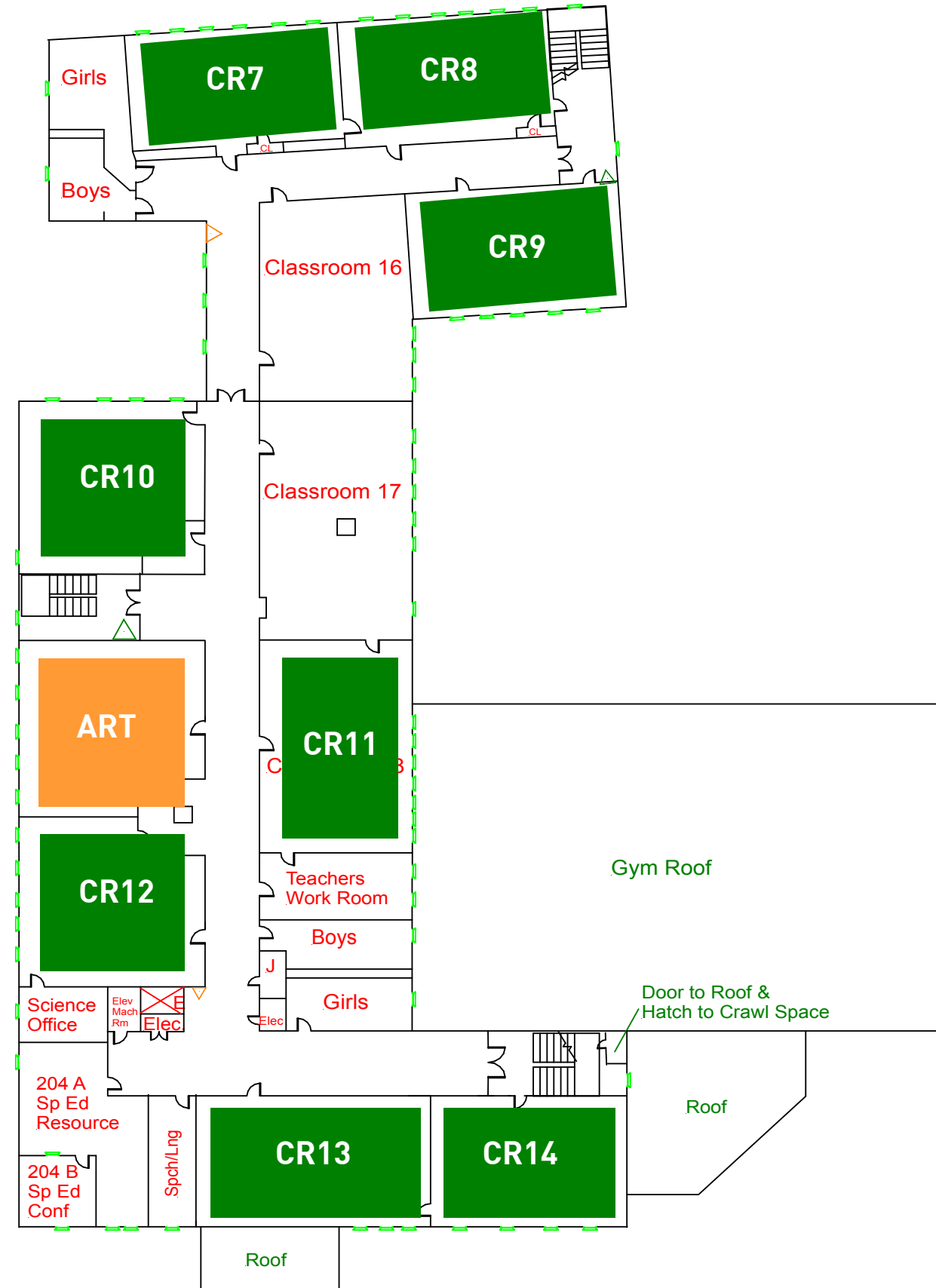

Side A



District:	Arlington
School Name:	Peirce Elementary School
Address:	85 Park Avenue Ext. Arlington, MA 02474
School Hours:	
In-session Contact:	Robert Penta (781) 316-3737
Off-Hours Contact:	
Approach Hazards:	
Notes:	

Side B

PEIRCE





Lower Level

Lower Level Floor

Side A

3

Legend

-  Single Door
-  Double Door
-  Window
-  Stairs
-  Ramp
-  Elevator
-  Fire Extinguisher
-  Gas Shut-Off
-  Electrical Shut-Off
-  Water Shut-Off
-  Chair Lift
-  Sprinkler Shutoff
-  Generator
-  Camera
-  Fire Standpipe

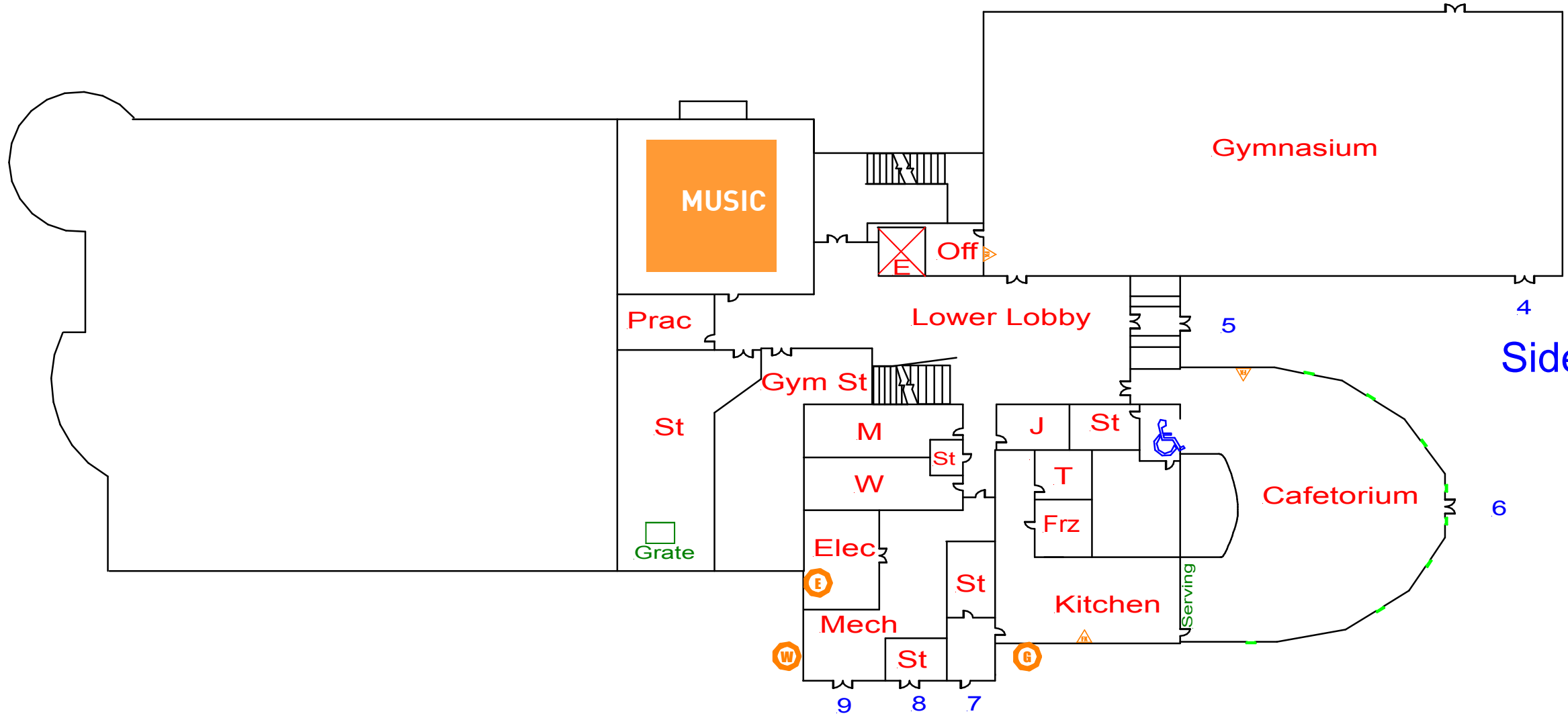

Side C

Side D



NORTHEAST HOMELAND SECURITY REGIONAL ADVISORY COUNCIL



PEIRCE

2nd Floor

District:	Arlington
School Name:	Peirce Elementary School
Address:	85 Park Avenue Ext. Arlington, MA 02474
School Hours:	
In-session Contact:	Robert Penta (781) 316-3737
Off-Hours Contact:	
Approach Hazards:	
Notes:	

Side B

2nd Floor

Side A

Side C

Side D

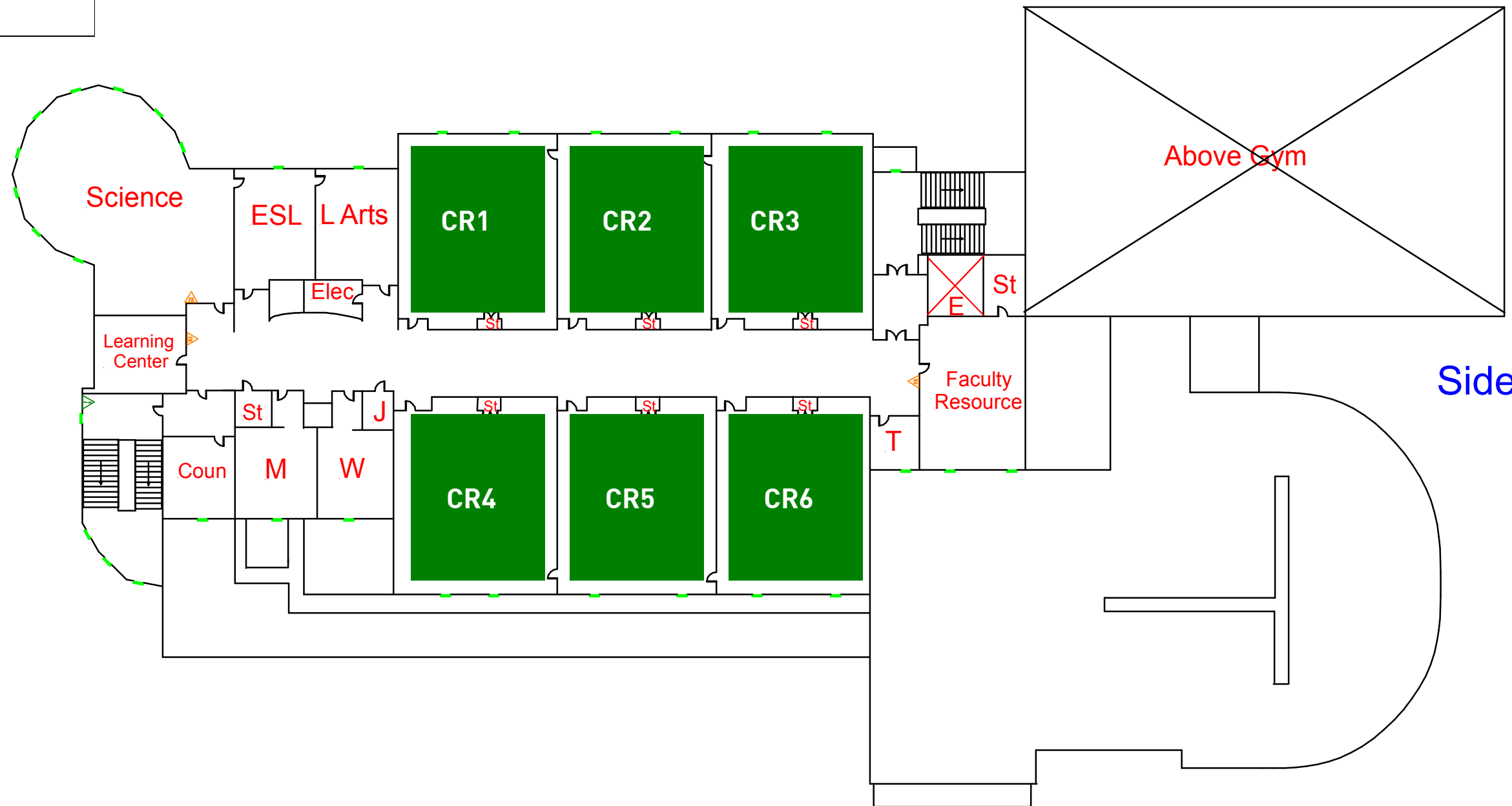

Legend

- Single Door
- Double Door
- Window
- Stairs
- Ramp
- Elevator
- Fire Extinguisher
- Gas Shut-Off
- Electrical Shut-Off
- Water Shut-Off
- Chair Lift
- Sprinkler Shutoff
- Generator
- Camera
- Fire Standpipe



District:	Arlington
School Name:	Peirce Elementary School
Address:	85 Park Avenue Ext. Arlington, MA 02474
School Hours:	
In-session Contact:	Robert Penta (781) 316-3737
Off-Hours Contact:	
Approach Hazards:	
Notes:	

PEIRCE

3rd Floor

Side B















3rd Floor

Side A

Side C

Side D

Legend

-  Single Door
-  Double Door
-  Window
-  Stairs
-  Ramp
-  Elevator
-  Fire Extinguisher
-  Gas Shut-Off
-  Electrical Shut-Off
-  Water Shut-Off
-  Chair Lift
-  Sprinkler Shutoff
-  Generator
-  Camera
-  Fire Standpipe

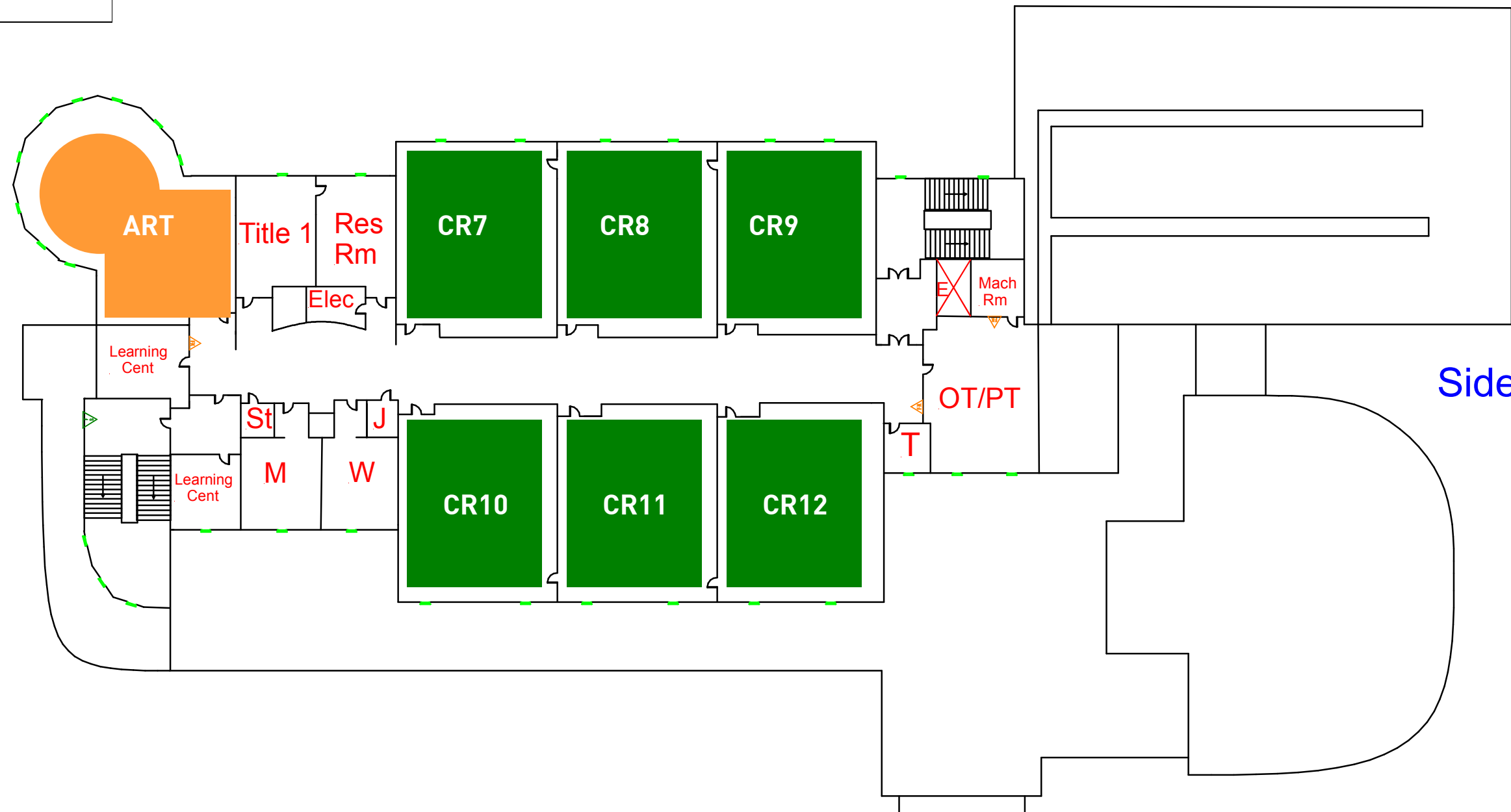

District:	Arlington
School Name:	Stratton Elementary School
Address:	180 Mountain Avenue Arlington, MA 02474
School Hours:	
In-session Contact:	Alan Brown (781) 316-3754
Off-Hours Contact:	
Approach Hazards:	
Notes:	

STRATTON

Upper Level

Side C

Upper Level
Floor

Side B

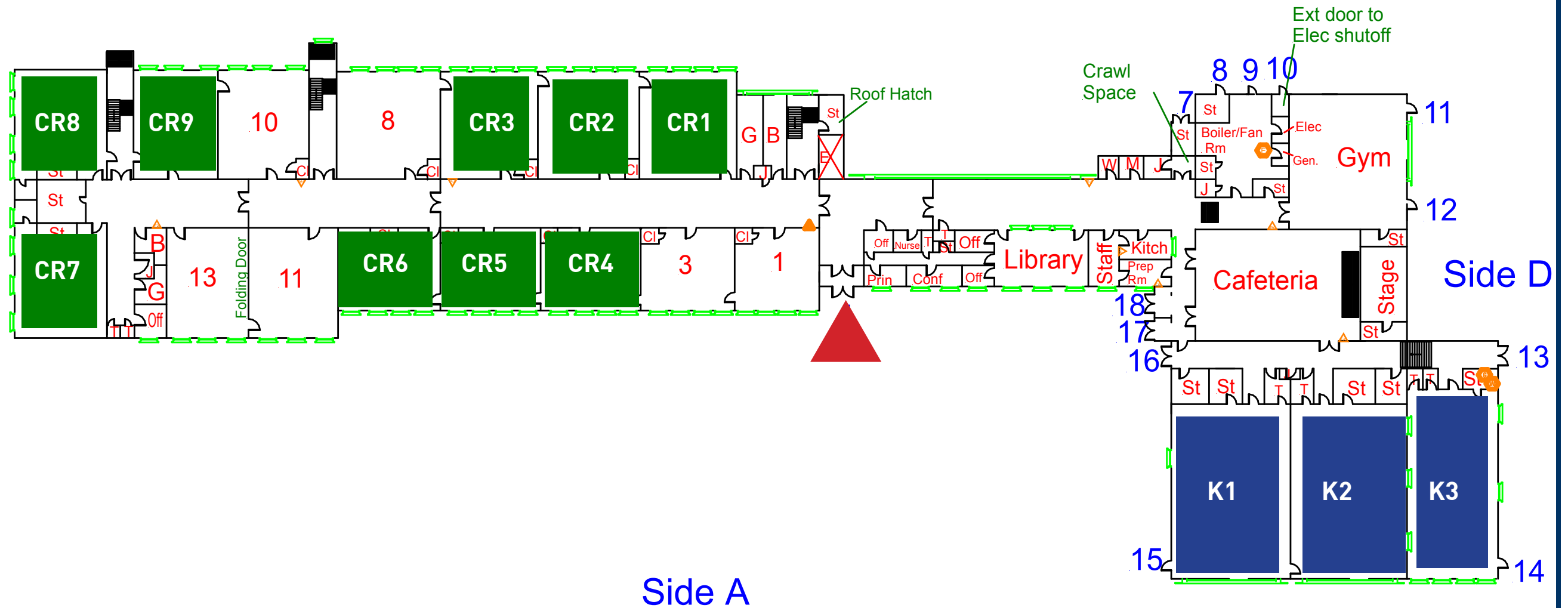

Legend

- Single Door
- Double Door
- Window
- Stairs
- Ramp
- Elevator
- Fire Extinguisher
- Gas Shut-Off
- Electrical Shut-Off
- Water Shut-Off
- Chair Lift
- Sprinkler Shutoff
- Generator
- Camera
- Fire Standpipe

Side A



With funding and support from:



District:	Arlington
School Name:	Stratton Elementary School
Address:	180 Mountain Avenue Arlington, MA 02474
School Hours:	
In-session Contact:	Alan Brown (781) 316-3754
Off-Hours Contact:	
Approach Hazards:	
Notes:	

STRATTON

Lower Level

Side C

Lower Level Floor
Side B

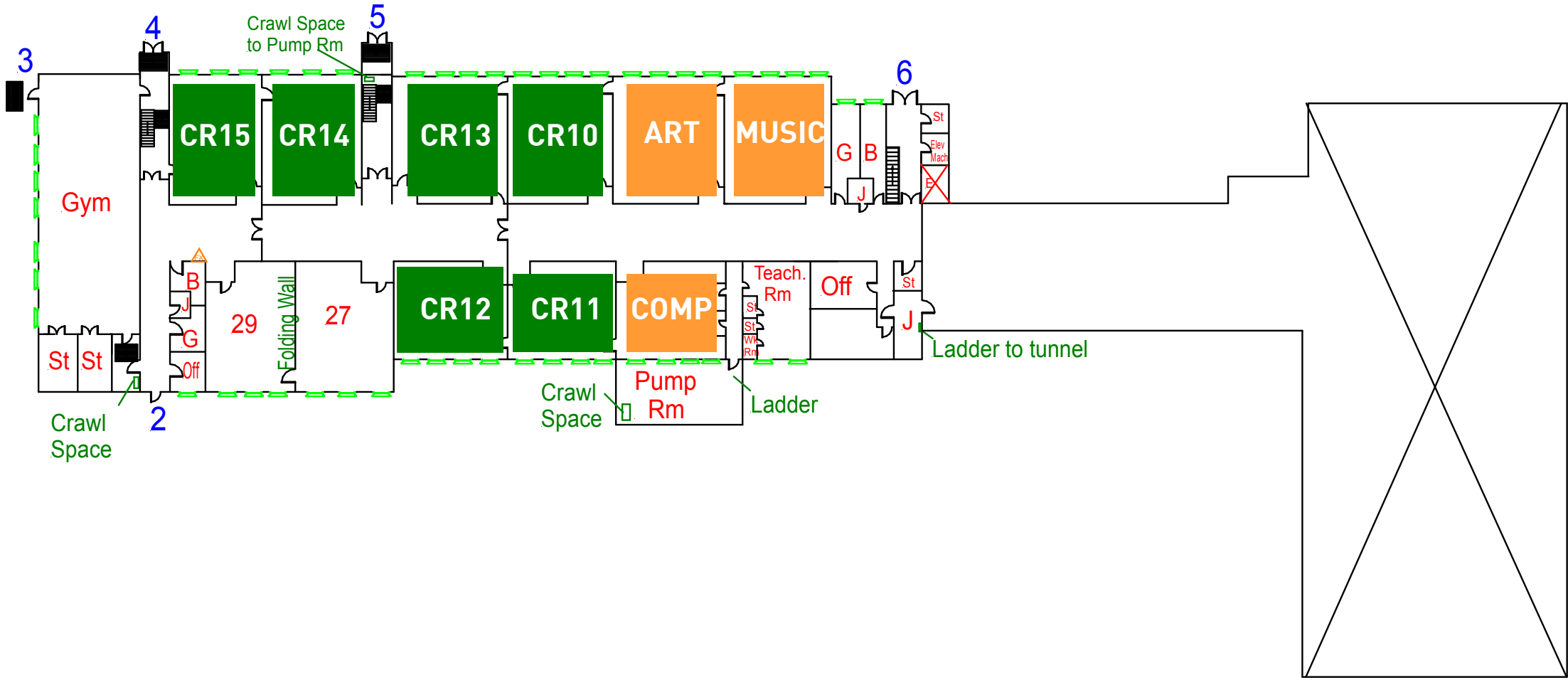

Side D

Legend

- Single Door
- Double Door
- Window
- Stairs
- Ramp
- Elevator
- Fire Extinguisher
- Gas Shut-Off
- Electrical Shut-Off
- Water Shut-Off
- Chair Lift
- Sprinkler Shutoff
- Generator
- Camera
- Fire Standpipe

Side A



THOMPSON

1st Floor

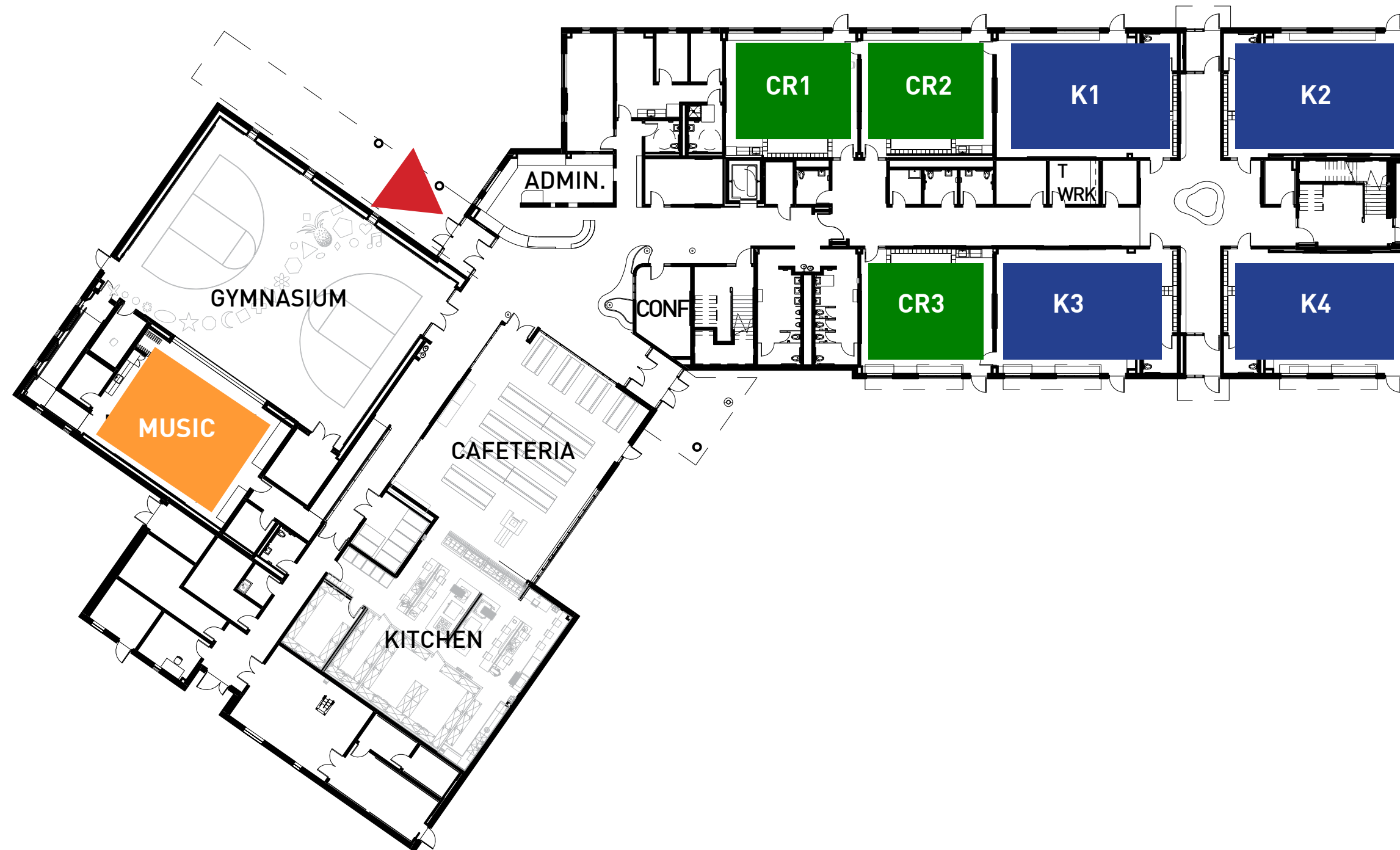

THOMPSON

2nd Floor



THOMPSON

3rd Floor



ARLINGTON SCHOOLS																							
SPACE PLANNING SCHEMES - APPENDIX E																							
SCHEME 1	SCHOOL	K QTY		CLASSRM QTY		2014-15	Sep-15	2015-16	Sep-16	2016-17	Sep-17	2017-18	Sep-18	2018-19	2019-20	2020-21	Sep-21	2021-22	2022-23	2023-24	2024-25	*COMPARATIVE COSTS	
		HAVE	NEED	HAVE	NEED																		
ES MODS/ 6TH @GIBBS/ 9-12 HS	BISHOP	3 Ks	3 Ks	15 CRs	15 CRs	415		433		439		437		438	433	437		433	432	432	434		
	BRACKETT	3 Ks	3 Ks	20 CRs	20 CRs	497		531		544	RELOCATE 2 SLC TO PEIRCE	550		575	584	578		564	552	541	531		
	DALLIN	4 Ks	4 Ks	15 CRs	15 CRs	456		462		451		451		460	456	458		453	448	442	434		
	HARDY	4 Ks	4 Ks	14 CRs	20 CRs	392		422	PLANNING	461	6 MODS	479	MODS STAY	494	505	504	MODS STAY	495	488	481	472		
	PEIRCE	3 Ks	3 Ks	12 CRs	12 CRs	276		271		275		265		260	257	250		241	239	236	235		
	STRATTON	3 Ks	3 Ks	15 CRs	15 CRs	408	PLANNING	423	MODS/ RENOVATE	440	MODS REMOVED/ STRATTON ONLINE	450		456	459	461		453	444	434	428		
	THOMPSON	4 Ks	4 Ks	15 CRs	20 CRs	392	PLANNING	433	6 MODS	463	MODS STAY	492	MODS STAY	489	502	496	MODS STAY	481	467	453	442		
	OTTOSON MIDDLE			42 CRs/ 24 SP	58 CRs/ 29 SP	1107		1121	PLANNING	1193	6 MODS - LEASED	1246	MODS REMOVED	847	862	854		904	978	994	971		
	GIBBS								GIBBS PLANNING		GIBBS RENOVATE		GIBBS ONLINE	439	450	495		528	512	504	497		
	ARLINGTON HIGH					1217		1246	9-12 HS PLANNING	1243		1300		1338	1371	1446	HS ONLINE	1467	1495	1540	1597	LOW	HIGH
																					\$19,012,830	\$25,835,370	
SCHEME 1A	SCHOOL	HAVE	NEED	HAVE	NEED	2014-15	Sep-15	2015-16	Sep-16	2016-17	Sep-17	2017-18	Sep-18	2018-19	2019-20	2020-21	Sep-21	2021-22	2022-23	2023-24	2024-25	*COMPARATIVE COSTS	
ES ADDS/ 6TH @GIBBS/ 9-12 HS	BISHOP	3 Ks	3 Ks	15 CRs	15 CRs	415		433		439		437		438	433	437		433	432	432	434		
	BRACKETT	3 Ks	3 Ks	20 CRs	20 CRs	497		531		544	RELOCATE 2 SLC TO PEIRCE	550		575	584	578		564	552	541	531		
	DALLIN	4 Ks	4 Ks	15 CRs	15 CRs	456		462		451		451		460	456	458		453	448	442	434		
	HARDY	4 Ks	4 Ks	14 CRs	20 CRs	392		422	6 CR ADD PLANNING	461	6 CR ADDITION ONLINE	479		494	505	504		495	488	481	472		
	PEIRCE	3 Ks	3 Ks	12 CRs	12 CRs	276		271		275		265		260	257	250		241	239	236	235		
	STRATTON	3 Ks	3 Ks	15 CRs	15 CRs	408	PLANNING	423	MODS/ RENOVATE	440	MODS REMOVED/ STRATTON ONLINE	450		456	459	461		453	444	434	428		
	THOMPSON	4 Ks	4 Ks	15 CRs	20 CRs	392		433	2 LEASED MODS/ 6 CR ADD PLANNING	463	MODS REMOVED/ 6 CR ADDITION ONLINE	492		489	502	496		481	467	453	442		
	OTTOSON MIDDLE			42 CRs/ 24 SP	58 CRs/ 29 SP	1107		1121	PLANNING	1193	6 MODS - LEASED	1246	MODS REMOVED	847	862	854		904	978	994	971		
	GIBBS								GIBBS PLANNING		GIBBS RENOVATE		GIBBS ONLINE	439	450	495		528	512	504	497		
	ARLINGTON HIGH					1217		1246	9-12 HS PLANNING	1243		1300		1338	1371	1446	HS ONLINE	1467	1495	1540	1597	LOW	HIGH
																						\$19,605,430	\$26,462,860

ARLINGTON SCHOOLS
SPACE PLANNING SCHEMES - APPENDIX E

SCHEME 2	SCHOOL	K QTY		CLASSRM QTY		2014-15	Sep-15	2015-16	Sep-16	2016-17	Sep-17	2017-18	Sep-18	2018-19	2019-20	2020-21	Sep-21	2021-22	2022-23	2023-24	2024-25	*COMPARATIVE COSTS
		HAVE	NEED	HAVE	NEED																	
ES TEMP MODS/ 5TH ^a @GIBBS/ 8- 12 HS	BISHOP	3 Ks	3 Ks	15 CRs	15 CRs	415		433		439		437		362	358	356		353	353	354	357	
	BRACKETT	3 Ks	3 Ks	20 CRs	20 CRs	497		531		544	RELOCATE 2 SLC TO PEIRCE	550		494	485	475		464	454	445	437	
	DALLIN	4 Ks	4 Ks	15 CRs	15 CRs	456		462		451		451		384	382	379		375	371	365	360	
	HARDY	4 Ks	4 Ks	14 CRs	20 CRs	392		422	PLANNING	461	2 LEASED MODS	479	MODS REMOVED	430	426	419		413	407	401	393	
	PEIRCE	3 Ks	3 Ks	12 CRs	12 CRs	276		271		275		265		214	209	201		199	197	194	194	
	STRATTON	3 Ks	3 Ks	15 CRs	15 CRs	408	PLANNING	423	MODS/ RENOVATE	440	MODS REMOVED/ STRATTON ONLINE	450		380	380	374		367	359	351	347	
	THOMPSON	4 Ks	4 Ks	15 CRs	20 CRs	392	PLANNING	433	2 LEASED MODS	463	+2 LEASED MODS	492	MODS REMOVED	424	418	406		393	381	369	361	
	GIBBS								GIBBS PLANNING		GIBBS RENOVATE		GIBBS ONLINE	484	538	574		556	548	540	527	
	OTTOSON MIDDLE			42 CRs/ 24 SP	58 CRs/ 29 SP	1107	PLANNING	1121	6 LEASED OR PURCHASED MODS	1193	MODS STAY	1246	+6 LEASED MODS	1286	1312	1349	MODS REMOVED	1008	1024	1001	986	
	ARLINGTON HIGH					1217		1246	8-12 HS PLANNING	1243		1300		1338	1371	1446	HS ONLINE	1891	1961	2037	2079	LOW

^a OR K, BUT HIGHER RENOVATION AND BUSSING COSTS, AND 3-STORY BUILDING IS NOT IDEAL FOR THE YOUNGEST STUDENTS

SCHEME 2A + INCREASES TO HS PROJECT COSTS ~\$38M LESS STATE REIMBURSEMENT

SHIFT 5TH TO OTTOSON, 7TH TO GIBBS, AND 8TH TO HS



ARLINGTON SCHOOLS																						
SPACE PLANNING SCHEMES - APPENDIX E																						
SCHEME 3	SCHOOL	K QTY		CLASSRM QTY		2014-15	Sep-16	2015-16	Sep-16	2016-17	Sep-17	2017-18	Sep-18	2018-19	2019-20	2020-21	Sep-21	2021-22	2022-23	2023-24	2024-25	*COMPARATIVE COSTS
		HAVE	NEED	HAVE	NEED																	
ES MODS/ MS MODS ^b / 9-12 HS	BISHOP	3 Ks	3 Ks	15 CRs	15 CRs	415		433		439		437		438	433	437		433	432	432	434	
	BRACKETT	3 Ks	3 Ks	20 CRs	20 CRs	497		531		544	RELOCATE 2 SLC TO PEIRCE	550		575	584	578		564	552	541	531	
	DALLIN	4 Ks	4 Ks	15 CRs	15 CRs	456		462		451		451		460	456	458		453	448	442	434	
	HARDY	4 Ks	4 Ks	14 CRs	20 CRs	392		422	PLANNING	461	6 MODS	479	MODS STAY	494	505	504	MODS STAY	495	488	481	472	
	PEIRCE	3 Ks	3 Ks	12 CRs	12 CRs	276		271		275		265		260	257	250		241	239	236	235	
	STRATTON	3 Ks	3 Ks	15 CRs	15 CRs	408	PLANNING	423	MODS/ RENOVATE	440	MODS REMOVED/ STRATTON ONLINE	450		456	459	461		453	444	434	428	
	THOMPSON	4 Ks	4 Ks	15 CRs	20 CRs	392	PLANNING	433	6 MODS	463	MODS STAY	492	MODS STAY	489	502	496	MODS STAY	481	467	453	442	
	OTTOSON MIDDLE			42 CRs/ 24 SP	58 CRs/ 29 SP	1107	PLANNING	1121	6 MODS	1193	MODS STAY	1246	+6 MODS	1286	1312	1349	+8 MODS	1432	1490	1498	1468	
	ARLINGTON HIGH					1217		1246	9-12 HS PLANNING	1243		1300		1338	1371	1446	HS ONLINE	1467	1495	1540	1597	LOW HIGH
	^b DOES NOT INCREASE CORE SHARED SPACES (CAFÉ, LIBRARY, GYM) OR SUPPORT SPACES (ADMIN, NURSE, GUIDANCE); COSTS DO NOT INCLUDE CODE UPGRADES TO OTTOSON																					\$11,520,000

ARLINGTON SCHOOLS																						
SPACE PLANNING SCHEMES - APPENDIX E																						
SCHEME 4	SCHOOL	K QTY		CLASSRM QTY		2014-15	Sep-15	2015-16	Sep-16	2016-17	Sep-17	2017-18	Sep-18	2018-19	2019-20	2020-21	Sep-21	2021-22	2022-23	2023-24	2024-25	*COMPARATIVE COSTS
		HAVE	NEED	HAVE	NEED																	
ES/MS TEMP MODS/ 5TH & 6TH @GIBBS ^c / 7TH & 8TH @ OTTOSON/ 9-12 HS	BISHOP	3 Ks	3 Ks	15 CRs	15 CRs	415		433		439		437		362	358	356		353	353	354	357	
	BRACKETT	3 Ks	3 Ks	20 CRs	20 CRs	497		531		544	RELOCATE 2 SLC TO PEIRCE	550		494	485	475		464	454	445	437	
	DALLIN	4 Ks	4 Ks	15 CRs	15 CRs	456		462		451		451		384	382	379		375	371	365	360	
	HARDY	4 Ks	4 Ks	14 CRs	20 CRs	392		422	PLANNING	461	2 LEASED MODS	479	MODS REMOVED - JULY	430	426	419		413	407	401	393	
	PEIRCE	3 Ks	3 Ks	12 CRs	12 CRs	276		271		275		265		214	209	201		199	197	194	194	
	STRATTON	3 Ks	3 Ks	15 CRs	15 CRs	408	PLANNING	423	MODS/RENOVATE	440	MODS REMOVED/STRATTON ONLINE	450		380	380	374		367	359	351	347	
	THOMPSON	4 Ks	4 Ks	15 CRs	20 CRs	392	PLANNING	433	2 LEASED MODS	463	+2 LEASED MODS	492	MODS REMOVED - JULY	424	418	406		393	381	369	361	
	GIBBS								GIBBS PLANNING		GIBBS ADD & RENOVATE		GIBBS ONLINE SEPT & DEC	923	988	1069		980	1014	1037	1009	
	OTTOSON MIDDLE			42 CRs/24 SP	58 CRs/29 SP	1107	PLANNING	1121	6 LEASED MODS	1193	MODS STAY	1246	MODS REMOVED - JAN 2019	847	862	854		1008	1024	1001	986	
	ARLINGTON HIGH					1217		1246	9-12 HS PLANNING	1243		1300		1338	1371	1446	HS ONLINE	1467	1495	1540	1597	LOW HIGH
^c SITE AND ADDITION WILL ONLY ACCOMMODATE CRS, THEREFORE NOT ENOUGH SUPPORT SPACE TO SERVE 1100 STUDENTS																					\$29,296,550	\$36,520,448
* The following cost assumptions were used:																						
Type																						
New construction																						
Renovation																						
Purchased modular																						
Leased modular																						
See the Space Planning Report for further information.																						



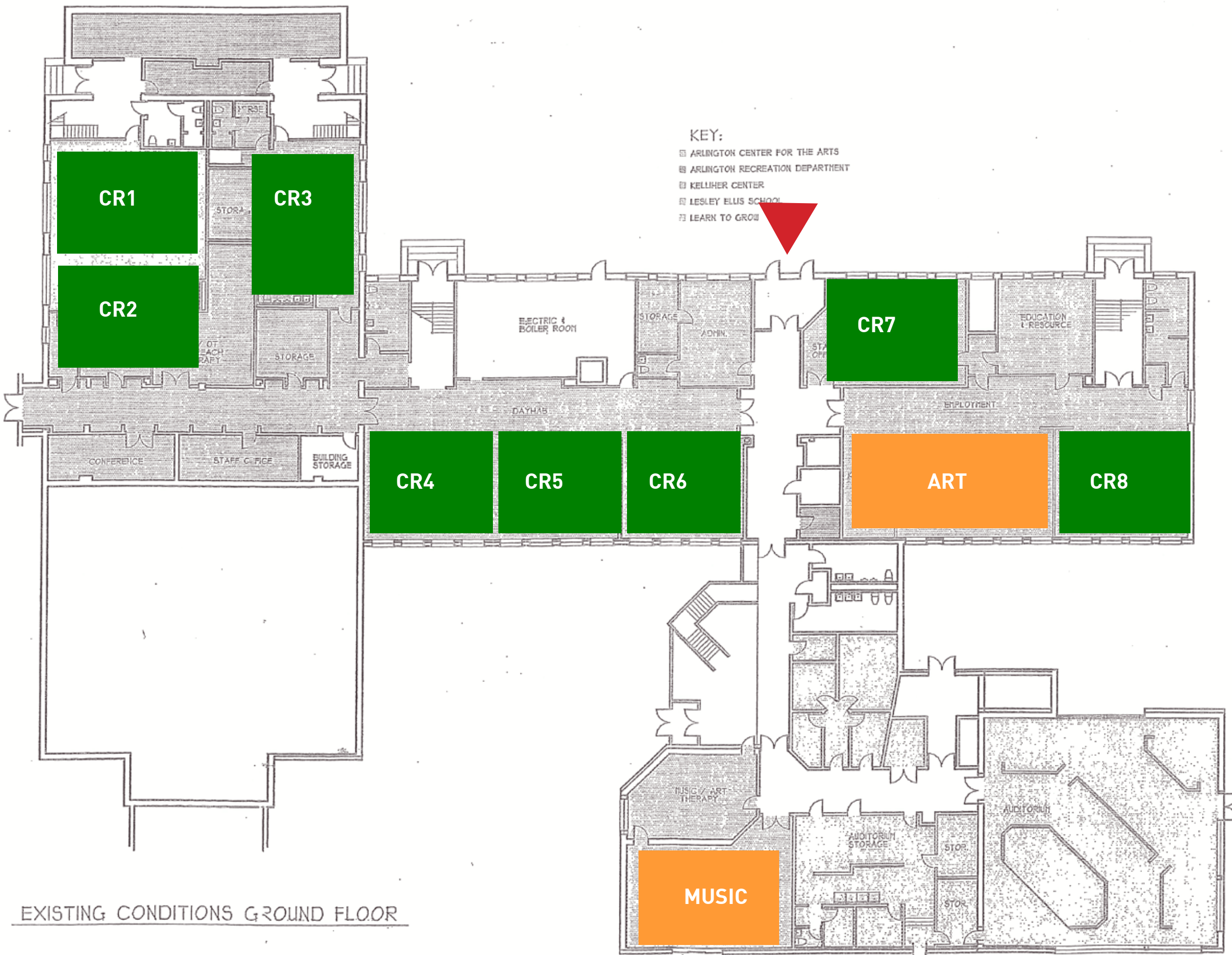

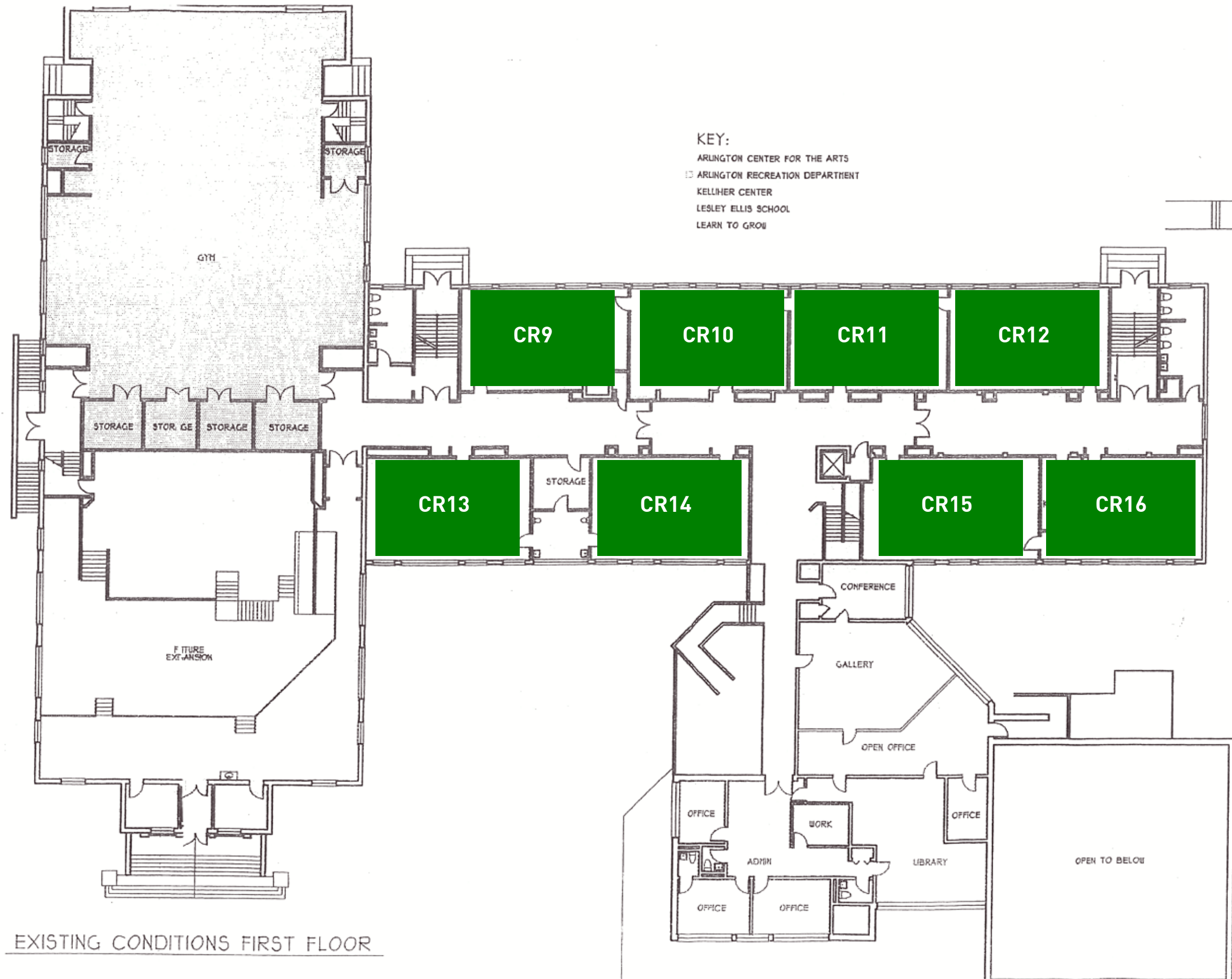

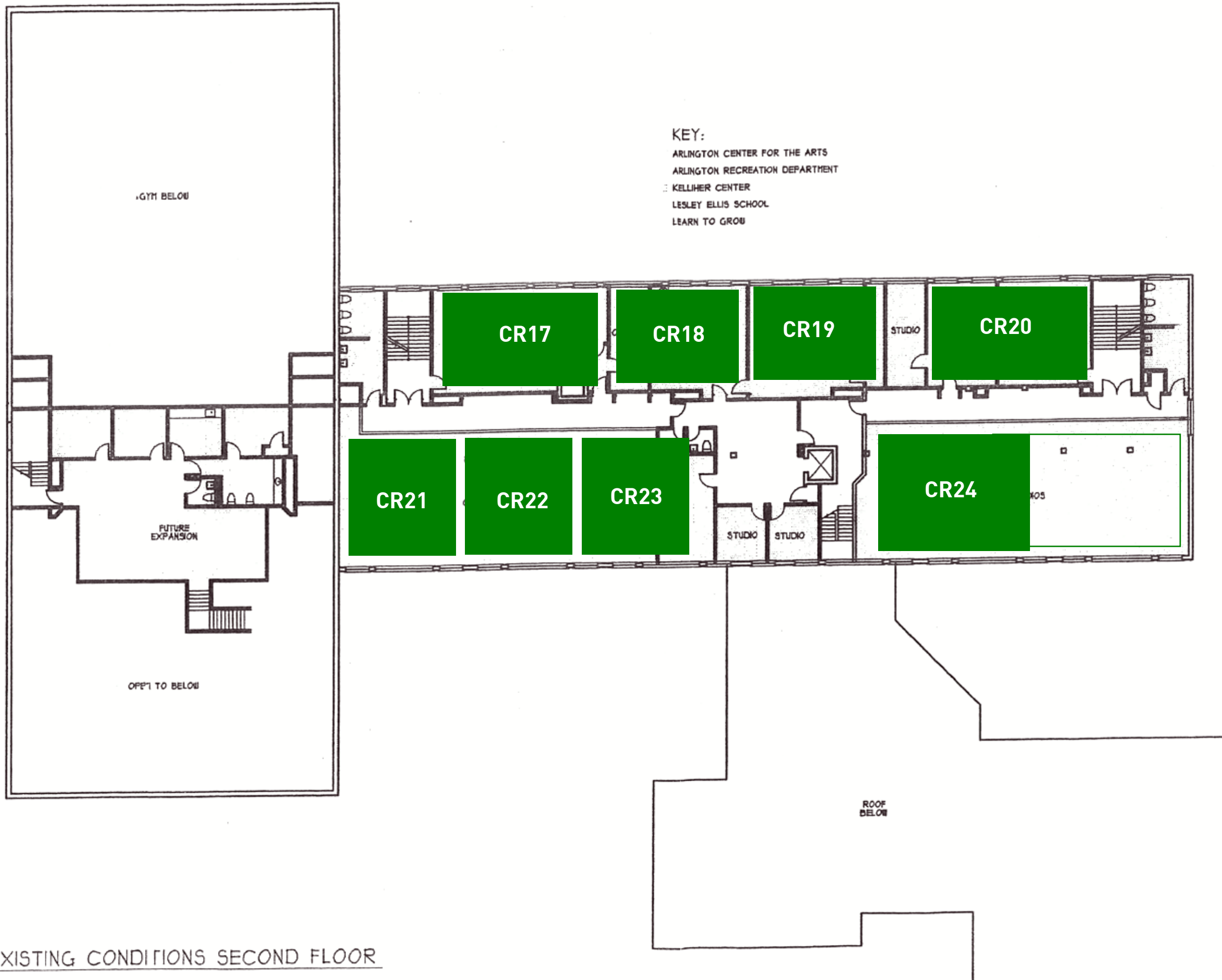

EXISTING CONDITIONS SECOND FLOOR