

5/16/2017

BID #17-32

**2017 WATER DISTRIBUTION SYSTEM
IMPROVEMENTS - VARIOUS LOCATIONS**

Town of Arlington, Massachusetts
Department of Public Works
51 Grove Street
Arlington, MA 02476

Table of Contents

Table of Contents	ii
I. Invitation for Bid	1
II. Instruction to Bidders	3
A. Receipt of Bids	3
B. Preparation of Bid	3
C. Bid Security	3
D. Time of Completion	4
E. Performance and Labor Material Bonds.....	4
F. Laws and Regulations.....	4
G. Withdrawal of Bids.....	4
H. Execution of Contract.....	4
I. Obligation of Bidder	5
J. Omissions, Discrepancies, Interpretations and Addenda	5
K. Record of Address	5
L. Massachusetts Sales and Use Tax	5
M. State Tax Affidavit	5
N. Minimum Wage Rates.....	5
O. Sub-bids.....	6
P. Supplemental Information	6
III. Proposal	7
Base Bid – Bow Street & Mill Street.....	8
Bid Alternate #1 – Spring Street	9
Bid Alternate #2 – Burch Street	11
BID SUMMARY	13
A. Financial Statement	15
B. Bidders Experience Record	15
C. Certification of Tax Compliance	16
D. CERTIFICATE OF NON-COLLUSION	17
IV. Contract.....	18
A. Definitions.....	18

- B. Parts of Contract 18
- C. Obligations of the Contractor 18
- D. Liability of the Contractor 18
- E. Authority of the Engineer 19
- F. Engineer to Decide..... 19
- G. Time for Commencing Work 19
- H. No Damages for Certain Delays 20
- I. Time for Completion 20
- J. Competent Persons to be Employed 20
- K. Access to Work..... 21
- L. Defective Work, Materials or Equipment 21
- M. Mistakes of Contractor 21
- N. Discrepancies, Errors and Omissions 21
- O. Right to Materials..... 22
- P. Compliance with Laws, Ordinances, and Regulations 22
- Q. Provisions Required by Law Deemed Inserted 22
- R. Work Hours 22
- S. Intoxicating Liquors..... 23
- T. Permits and Notices 23
- U. Patents 23
- V. Insurance..... 23
- W. Work Not to be Sublet or Assigned..... 24
- X. Alterations..... 24
- Y. Extra Work 25
- Z. Extension of Time on Account of Extra Work 26
- AA. Changes Not to Affect Bonds 26
- BB. Completion of Work if Contract is Not Fulfilled..... 26
- CC. Compensation for Work..... 27
- DD. Money may be Retained 27
- EE. Estimates and Payments..... 27
- FF. Partial Payment Not Acceptance 28

GG.	Liens	28
HH.	Waiver	28
II.	Liability of the Town of Arlington	29
JJ.	Guarantee	29
KK.	Money Retained for Repairs	29
LL.	Address of Contractor	30
MM.	CERTIFICATE of VOTE	31
V.	PERFORMANCE BOND.....	32
VI.	General Conditions	34
A.	Definitions.....	34
B.	Abbreviations	34
C.	Handling Materials.....	35
D.	Storage Room.....	35
E.	Shop Drawings, Schedules, and Descriptive Matter	35
F.	Equivalents.....	35
G.	Materials and Workmanship.....	36
H.	Inspection by the Engineer	36
I.	Documents at Site of Work.....	36
J.	Lines and Grades	36
K.	Scaffolding and Protection.....	36
L.	Public Safety and Property of Others.....	36
M.	Existing Structures, Pipes, Conduits, Etc.	36
N.	Sanitary Provisions	37
O.	Cutting and Patching.....	37
P.	Debris	37
Q.	Measurement of Quantities.....	37
R.	Compliance with Occupational Safety and Health Act of 1970	37
S.	Order of Precedence Governing Specifications	37
T.	Affirmative Action/Anti-Discrimination	38
1.	Compliance with Requirements.....	39
2.	Non-Discrimination	39

3.	Solicitations for Sub-Contracts, and for the Procurement of Materials and Equipment.....	39
4.	Bidders Certification Requirement	40
5.	Contractor’s Certification.....	40
6.	Compliance-Information, Reports and Sanctions	40
7.	Severability.....	41
VII.	SPECIAL CONDITIONS.....	42
A.	SCOPE OF SPECIAL CONDITIONS	42
B.	MINIMUM LIMITS FOR INSURANCE	42
C.	RETAINAGE.....	42
D.	PAYMENT OF SUMS DUE CONTRACTOR	42
E.	DISPOSAL OF EXCAVATED MATERIAL	42
F.	EXCERPTS FROM CERTAIN LAWS	42
G.	REGULATIONS OF THE COMMONWEALTH OF MASSACHUSETTS.....	43
H.	ADJACENT CONTRACTS	43
I.	TRAFFIC ORDERS	43
J.	TIME FOR COMPLETION AND LIQUIDATED DAMAGES.....	44
K.	RESTORATION OF SURFACE	44
L.	PROTECTION OF TREES	44
M.	INTERPRETATION OF CONTRACT	44
N.	CONTROL OF WATER SYSTEM.....	44
O.	CONTROL OF AND NOTICE TO ABUTTERS OF INTERRUPTION OF WATER SERVICE.....	45
P.	AWARD OF CONTRACT.....	45
Q.	WORKSITE DUST CONTROL	45
R.	CONSTRUCTION SEQUENCE.....	45
VIII.	REMOVAL OF UNDERGROUND NON - FRIABLE ASBESTOS CEMENT PIPE	46
A.	GENERAL	46
B.	SUBMITTALS:.....	46
C.	GENERAL APPLICABILTY CODED, REGULATIONS AND STANDARDS:.....	46
D.	MATERIALS.....	47
E.	CONSTRUCTION METHODS.....	48
1.	General.....	48

2.	ASBESTOS CEMENT PIPE DURING EXCAVATION:.....	48
3.	ASBESTOS CEMENT PIPE LEFT IN PLACE	49
4.	ASBESTOS CEMENT PIPE DISPOSAL PROCEDURES.....	49
F.	MEASUREMENT AND PAYMENT	49
IX.	EXCAVATION AND BACKFILL	50
A.	GENERAL	50
B.	CLASSIFICATION	50
C.	CONSTRUCTION METHODS.....	51
1.	GENERAL	51
2.	TRENCH EXCAVATION	54
3.	MISCELLANEOUS TRENCH EXCAVATION.....	54
4.	TRENCH ROCK EXCAVATION	54
5.	UNSUITABLE BACKFILL MATERIAL	55
D.	MEASUREMENT AND PAYMENT	56
X.	GRAVEL.....	57
A.	GENERAL	57
B.	MATERIAL.....	57
C.	CONSTRUCTION METHODS.....	57
D.	MEASUREMENT AND PAYMENT	57
XI.	DUCTILE IRON PIPE AND FITTINGS.....	58
A.	GENERAL	58
B.	MATERIALS.....	58
C.	CONSTRUCTION METHODS.....	59
B.	THRUST RESTRAINT	60
D.	MEASUREMENT AND PAYMENT	62
E.	NEW CEMENT LINED DUCTILE IRON PIPE	63
F.	PIPE FITTINGS.....	63
XII.	GATE VALVES AND BOXES.....	64
A.	GENERAL	64
B.	MATERIALS.....	64
1.	GENERAL	64

2.	VALVE BOXES	64
3.	CONSTRUCTION METHODS	64
4.	MEASUREMENT AND PAYMENT	65
XIII.	POST HYDRANTS	66
A.	GENERAL	66
B.	MATERIALS	66
C.	CONSTRUCTION METHODS.....	66
D.	MEASUREMENT AND PAYMENT	66
E.	HYDRANT REPLACEMENT AND NEW HYDRANT.....	67
F.	HYDRANT REMOVE AND RESET	67
XIV.	TEMPORARY BY-PASS SYSTEM.....	68
A.	GENERAL	68
B.	MATERIALS	68
C.	CONSTRUCTION METHODS.....	69
D.	MEASUREMENT AND PAYMENT	70
E.	TERMPORARY BYPASS WATER LINES AND SERVICES.....	70
XV.	SERVICE LINES	72
A.	GENERAL	72
B.	SERVICE RENEWAL	72
C.	MATERIALS.....	72
D.	CONSTRUCTION METHODS.....	73
1.	GENERAL	73
2.	SERVICE LINES	74
3.	CORPORATION STOPS	74
4.	CURB STOPS	75
E.	MEASUREMENT AND PAYMENT	75
XVI.	BITUMINOUS CONCRETE PAVING AND CONCRETE WALKS.....	77
A.	GENERAL	77
B.	CLASSIFICATION	77
C.	MATERIALS.....	78
D.	CONSTRUCTION METHODS.....	78

1.	GENERAL	78
2.	MAINTENANCE PERIOD OF ROADWAY SURFACE	79
3.	MEASUREMENT AND PAYMENT	79
XVII.	Town of Arlington By-Law Title 1 Article 16.....	80

I. Invitation for Bid

Sealed bids are invited and will be received by the Town Manager, Town of Arlington, Massachusetts, until **11:00 A.M., Thursday, June 8, 2017** at the Office of the Purchasing Agent, Town Hall, Arlington, Massachusetts 02476, at which time and place they will be publicly opened and read.

A BID DEPOSIT IN THE FORM OF CASH, CERTIFIED CHECK, OR TREASURER'S CHECK, shall accompany every bid. The amount of such bid deposit shall be FIVE PERCENT (5%) of the value of the bid.

Specifications and proposal forms will be available on the Town of Arlington's purchasing web site (<http://www.arlingtonma.gov/departments/purchasing>) or at the Office of the Purchasing Agent, Town Hall, Arlington, Massachusetts. All bids must be in sealed envelopes plainly marked: **Bid On: Water Distribution System Improvements, BID #17-32**

The conditions of employment as set forth in Sections 26 to 27D and 27F of Chapter 149 of the General Laws, as amended, shall prevail in the execution of the work under this contract.

Attention is called to the fact that minimum wage rates and health, welfare, and pension fund contributions are established for this contract and are a part of the specifications.

Work under this contract shall be governed by M.G.L.Ch.30, Sec. 39M.

Attestation Forms pursuant to M.G.L. Ch. 62C, Sec. 49A and M.G.L. Ch. 701 of the Acts of 1983 are enclosed and shall be submitted with bids.

By-law of the Town of Arlington, Title 1, Article 16, Minority/Woman Workforce Participation in Construction Projects which exceed \$200,000.00 is part and parcel of the bid.

Proposals are for Water Distribution System Improvement Work, including water main replacement, on Bow Street (Base Bid), Mill Street (Base Bid), Spring Street (Bid Alternate #1), and Burch Street (Bid Alternate #2) in the Town of Arlington, MA.

A Pre-Bid Meeting will be held at the Town of Arlington Engineering Office on Wednesday, **May 4, 2017 at 10:00 AM**. The Engineering Office is located on the Second Floor at 51 Grove Street in Arlington, MA.

Pre-Bid questions shall be submitted in writing to Assistant Town Engineer William Copithorne (wcopithorne@town.arlington.ma.us) by Tuesday, May 30, 2017, at 4:00 PM.

It is the intention of the Owner to award the Contract to the lowest qualified responsive bidder. The bidder must submit a bid on all bid items in the Contract.

All proposals to include prices both writing and in figures, and must be signed by the bidder with her/his business address.

An increase or decrease in the quantity of work shall not be regarded as a sufficient ground for an increase in the unit prices.

To receive consideration, bids must be in the hands of the Purchasing Agent or her/his authorized representative not later than the day and hour *above* mentioned. For further information relative to this bid, please confer with Domenic R. Lanzillotti, Director, Purchasing Department, Town Hall, Arlington, Massachusetts, 02476.

OSHA Construction Training Required: As of July 1, 2006, under M.G.L. Chapter 30, Section 39s, any person, submitting a bid for, or signing a contract to work on, the construction, reconstruction, alteration, remodeling or repair of any public work by the Commonwealth of

Massachusetts/Town of Arlington, and estimated by the awarding Authority to cost more than \$10,000, shall certify on the Bid or Contract, under penalty of perjury, that all employees to be employed at the work will have successfully completed a course in construction safety and health approved by the United States Occupational Safety and Health Administration that is at least 10 hours in duration

The Town Manager reserves the right to cancel any invitation for bids, to reject in whole or in part any and all bids, when it is deemed in the best interest of the Town of Arlington to do so.

TOWN OF ARLINGTON

Adam W. Chapdelaine
Town Manager
Date: May 16, 2017

II. Instruction to Bidders

A. Receipt of Bids

The Town may consider informal any bid not prepared and submitted in accordance with the provisions hereof and may waive any informality in or reject any bids. Any bid may be withdrawn before the time for the opening of bids. Any bid received after the time and date specified shall not be considered. No bidder may withdraw her/his bid for a period of 30 days, excluding Saturdays, Sundays, and legal holidays after actual date of the opening thereof.

B. Preparation of Bid

Each bid shall be submitted on the forms attached to these documents. The bid forms may be removed and submitted separately from the other documents. All blank spaces for bid prices must be filled in with the unit price for the item or the lump sum for which the proposal is made. Bidders must bid on each item. All entries in the entire proposal must be made clearly, and prices written in both words and figures in the spaces provided.

Each bid must be in a sealed envelope addressed to the Office of the Purchasing Agent, 730 Massachusetts Avenue, Arlington, Massachusetts, 02476; and bearing on the outside the name of the bidder, her/his address, the name of the project for which the bid is submitted, and the notation **Bid On: 2017 Water Distribution System Improvements – Various Locations, BID #17-31.**

C. Bid Security

Every bid submitted by contractors shall be accompanied by a bid deposit in the form of cash, certified check, treasurer's or cashier's check, or a bid bond issued by a responsible bank or trust company and made payable to the Town of Arlington. The amount of the bid deposit shall be 5% of the amount of the bid. All security except those of the three lowest responsible and eligible bidders will be returned within ten days, Saturdays, Sundays, and legal holidays excluded, after opening of the bid. All bid securities will be returned on the execution of the contract or if no award is made within 30 days, excluding Saturdays, Sundays, and legal holidays, after the actual date of the opening thereof, unless forfeited under the conditions herein stipulated.

In case a party to whom a contract is awarded shall fail or neglect to execute the contract and furnish the satisfactory bond in the time specified, the Town may determine the bidder has abandoned the contract and thereupon the proposal and acceptance shall be null and void, and the bid security accompanying the proposal shall be forfeited to the Town as liquidation damages for such failure or neglect and indemnify the Town for any loss which may be sustained by failure of the bidder to execute the contract and furnish the bonds as aforesaid, provided that, in case of death, disability, or other unforeseen circumstances affecting the bidder, such bid security may be returned to him/her.

After execution of the contract and acceptance of the bonds by the Town, the bid security accompanying the proposal of the successful bidder will be returned.

D. Time of Completion

The bidder must agree to commence work within thirty (30) business days from the date of signing the contract and to fully complete the project within the time specified within the Special Provisions section of this document.

E. Performance and Labor Material Bonds

A bond in the sum of 50% of the total amount of the Contract by the successful bidder and an additional bond in equal amount covering the payment for all labor and materials used in the work will be required. A surety company authorized to do business in Massachusetts and satisfactory to the Town of Arlington must provide these bonds. These bonds will be required at the execution of the contract. Attorneys-in-fact who sign contract bonds must file with each bond a certified and effectively dated copy of their power of attorney.

F. Laws and Regulations

The bidder's attention is directed to the fact that all applicable State laws, Town of Arlington Bylaws, municipal ordinances, and the rules and regulations of all authorities having jurisdiction over construction of the project shall apply to the contract throughout, and they shall be deemed to be included in the contract the same as though herein written out in full.

G. Withdrawal of Bids

Upon proper written request and identification, Bids may be withdrawn only as follows:

1. At any time before the designated time for the opening of Bids.
2. Death or serious injury of a principal.
3. With the written approval of the Town of Arlington Office of the Purchasing Director.
4. At any time after the expiration of the period during which withdrawal is prohibited, provided the bid has not been accepted by the Town.

H. Execution of Contract

The party to whom the contract is awarded shall be required to execute the contract and furnish the bonds duly executed with a satisfactory surety company within 10 days, excluding Saturdays, Sundays, and legal holidays, of the date of the mailing of the notice to the bidder according to the address given by him/her, that the contract is ready for execution.

I. Obligation of Bidder

At the time of the opening of bids, each bidder shall be presumed to have read and to be thoroughly familiar with the contract documents. The failure or omission of any bidder to receive or examine any form, instrument, or documents shall in no way relieve any bidder from the obligation in respect to her/his bid.

J. Omissions, Discrepancies, Interpretations and Addenda

Should a bidder find discrepancies in, or omissions from, the drawings or contract documents, or should s/he have questions as to the interpretation of the plans or contract documents s/he shall submit such in writing to the Assistant Town Engineer and the Director of Purchasing at least five (5) days before the date herein set for the opening of bids. An interpretation will be posted to the Town purchasing website and notification sent by email to all registered bidders at the addresses given by them on or about two (2) days before the opening of bids. Signed copies of all addenda shall be included with the bid; omission of the signed addendum shall be cause for rejection of the bid.

K. Record of Address

Prospective bidders shall at the time plans and specifications are secured place on file with the Director of Purchasing their address and email address, and are required to make any changes necessary to insure that the record is accurate, complete, and up to date. Prospective bidders shall notify the Director of Purchasing if they do not have an email address.

L. Massachusetts Sales and Use Tax

Materials purchased for permanent installation in the work will be exempt from the Massachusetts Sales and Use tax. Each bidder shall consider this exemption in calculating her/his bid for the work.

M. State Tax Affidavit

Prospective bidders are required to certify that all state tax returns have been filed and all state taxes have been paid in order to be eligible to enter into a contract with the Town on this project. The included form is to be used for this purpose and is to be completed and returned as part of the bid and proposal.

N. Minimum Wage Rates

Prevailing rates for wages for work performed under this Contract will be as predetermined by the Commissioner of Labor and Industries of the Commonwealth of Massachusetts in accordance with the provisions of Sections 26 to 27D, inclusive, of c.149 of M.G.L. A schedule of the prevailing wages is included in the Minimum Wage Rates Section.

O. Sub-bids

No sub bids shall be sought in connection with this Contract.

P. Supplemental Information

All bidders shall submit the following supplemental information with a fee proposal:

1. Name, address, and phone number of a minimum of three (3) references that can vouch for the performance of the bidder;
2. Proof of Liability and Worker's Compensation Insurance Coverage;
3. Completed tax attestation form;
4. Bid deposit.

III. Proposal

For Bid #17-32: **2017 Water Distribution System Improvements – Various Locations:**

To the Town of Arlington, Massachusetts, acting through its Town Manager, the undersigned, as bidder, declares as follows:

- A. The only persons or parties interested in this proposal as principals are named in this proposal;
- B. This proposal is made without collusion with any other person, firm or corporation;
- C. S/he has carefully examined the location of the proposed work and the annexed proposed form of contract, and the drawings and specifications therein referred to;
- D. This proposal is based solely on her/his review of the contract documents and own investigation and research, and not in reliance upon any plans, surveys, measurements, dimensions, calculations, estimates, borings, test pits, soundings, or representations of any employee, officer, or agent of the Town;

and the undersigned proposes and agrees that if this proposal is accepted, s/he will contract with the Town, this Proposal form being part of and included in said contract, to provide all necessary machinery, tools, apparatus and other means of construction and to furnish all the labor, supervision, materials, permits and other requisites not expressly stated, necessary to complete the contract in the manner and time therein prescribed and according to the requirements of the plans and specifications; and that s/he will take in full payment thereof the following sums to with:

Base Bid – Bow Street & Mill Street

ITEM #	QUANTITY	UNIT	DESCRIPTION	UNIT PRICE	AMOUNT
1	1	L.S.	FURNISH & INSTALL & REMOVE TEMPORARY BYPASS, WATER LINES & SERVICE		
2a	2,900	L.F.	FURINISH & INSTALL 12" CEMENT LINED DUCTILE IRON PIPE & FITTINGS		
2b	850	L.F.	FURINISH & INSTALL 8" CEMENT LINED DUCTILE IRON PIPE & FITTINGS		
2c	175	L.F.	FURINISH & INSTALL 6" CEMENT LINED DUCTILE IRON PIPE & FITTINGS		
2d	30	L.F.	FURINISH & INSTALL 4" CEMENT LINED DUCTILE IRON PIPE & FITTINGS		
3a	20	EA.	FURNISH & INSTALL 12" GATE VALVE & GATE VALVE BOX		
3b	9	EA.	FURNISH & INSTALL 8" GATE VALVE & GATE VALVE BOX		
3c	7	EA,	FURNISH & INSTALL 6" GATE VALVE & GATE VALVE BOX		
3d	2	EA.	FURNISH & INSTALL 4" GATE VALVE & GATE VALVE BOX		
4	9	EA.	FURNISH & INSTALL 6" HYDRANT GATE VALVE & GATE VALVE BOX		
5a	5	EA.	REMOVE EXISTING HYDRANT, FURNISH & INSTALL NEW HYDRANT & 6"HYDRANT BRANCH		
5b	4	EA.	REMOVE AND RESET EXISTING HYDRANT INCLUDING NEW 6" HYDRANT BRANCH		
6a	48	EA.	FURNISH & SET 3/4" CORPORATION COCK		
6b	3	EA.	FURNISH & SET 1" CORPORATION COCK		
6c	4	EA.	FURNISH & SET 2" CORPORATION COCK		
7a	48	EA.	FURNISH & SET 3/4 " CURB STOP & BOX		
7b	3	EA.	FURNISH & SET 1 " CURB STOP & BOX		
7c	4	EA.	FURNISH & SET 2 " CURB STOP & BOX		
8a	1,450	L.F.	FURNISH & INSTALL 3/4" COPPER SERVICE PIPE & FITTINGS		

8b	100	L.F.	FURNISH & INSTALL 1" COPPER SERVICE PIPE & FITTINGS		
8c	150	L.F.	FURNISH & INSTALL 2" COPPER SERVICE PIPE & FITTINGS		
9	100	C.Y.	TRENCH ROCK EXCAVATION		
10	25	C.Y.	MISCELLANEOUS TRENCH EXCAVATION		
11	2,950	C.Y.	UNSUITABLE TRENCH MATERIAL		
12	25	L.F.	REMOVAL, DISPOSAL, & HANDLING OF EXISTING TRANSITE PIPE		
Base Bid – Bow Street & Mill Street					

Bid Alternate #1 – Spring Street

ITEM #	QUANTITY	UNIT	DESCRIPTION	UNIT PRICE	AMOUNT
13	1	L.S.	FURNISH & INSTALL & REMOVE TEMPORARY BYPASS, WATER LINES & SERVICE		
14a	300	L.F.	FURINISH & INSTALL 12" CEMENT LINED DUCTILE IRON PIPE & FITTINGS		
14b	0	L.F.	FURINISH & INSTALL 8" CEMENT LINED DUCTILE IRON PIPE & FITTINGS		
14c	0	L.F.	FURINISH & INSTALL 6" CEMENT LINED DUCTILE IRON PIPE & FITTINGS		
14d	0	L.F.	FURINISH & INSTALL 4" CEMENT LINED DUCTILE IRON PIPE & FITTINGS		
15a	2	EA.	FURNISH & INSTALL 12" GATE VALVE & GATE VALVE BOX		
15b	0	EA.	FURNISH & INSTALL 8" GATE VALVE & GATE VALVE BOX		
15c	0	EA,	FURNISH & INSTALL 6" GATE VALVE & GATE VALVE BOX		
15d	0	EA.	FURNISH & INSTALL 4" GATE VALVE & GATE VALVE BOX		

16	0	EA.	FURNISH & INSTALL 6" HYDRANT GATE VALVE & GATE VALVE BOX		
17a	0	EA.	REMOVE EXISTING HYDRANT, FURNISH & INSTALL NEW HYDRANT & 6"HYDRANT BRANCH		
17b	0	EA.	REMOVE AND RESET EXISTING HYDRANT INCLUDING NEW 6"HYDRANT BRANCH		
18a	4	EA.	FURNISH & SET 3/4" CORPORATION COCK		
18b	0	EA.	FURNISH & SET 1" CORPORATION COCK		
18c	0	EA.	FURNISH & SET 2" CORPORATION COCK		
19a	4	EA.	FURNISH & SET 3/4 " CURB STOP & BOX		
19b	0	EA.	FURNISH & SET 1 " CURB STOP & BOX		
19c	0	EA.	FURNISH & SET 2 " CURB STOP & BOX		
20a	100	L.F.	FURNISH & INSTALL 3/4" COPPER SERVICE PIPE & FITTINGS		
20b	0	L.F.	FURNISH & INSTALL 1" COPPER SERVICE PIPE & FITTINGS		
20c	0	L.F.	FURNISH & INSTALL 2" COPPER SERVICE PIPE & FITTINGS		
21	25	C.Y.	TRENCH ROCK EXCAVATION		
22	10	C.Y.	MISCELLANEOUS TRENCH EXCAVATION		
23	225	C.Y.	UNSUITABLE TRENCH MATERIAL		
24	0	L.F.	REMOVAL, DISPOSAL, & HANDLING OF EXISTING TRANSITE PIPE		
				Bid Alt. #1 Subtotal	
				Base Bid + Bid Alt. #1	

Bid Alternate #2 – Burch Street

ITEM #	QUANTITY	UNIT	DESCRIPTION	UNIT PRICE	AMOUNT
25	1	L.S.	FURNISH & INSTALL & REMOVE TEMPORARY BYPASS, WATER LINES & SERVICE		
26a	20	L.F.	FURNISH & INSTALL 12" CEMENT LINED DUCTILE IRON PIPE & FITTINGS		
26b	950	L.F.	FURNISH & INSTALL 8" CEMENT LINED DUCTILE IRON PIPE & FITTINGS		
26c	30	L.F.	FURNISH & INSTALL 6" CEMENT LINED DUCTILE IRON PIPE & FITTINGS		
26d	0	L.F.	FURNISH & INSTALL 4" CEMENT LINED DUCTILE IRON PIPE & FITTINGS		
27a	1	EA.	FURNISH & INSTALL 12" GATE VALVE & GATE VALVE BOX		
27b	11	EA.	FURNISH & INSTALL 8" GATE VALVE & GATE VALVE BOX		
27c	0	EA.	FURNISH & INSTALL 6" GATE VALVE & GATE VALVE BOX		
27d	0	EA.	FURNISH & INSTALL 4" GATE VALVE & GATE VALVE BOX		
28	0	EA.	FURNISH & INSTALL 6" HYDRANT GATE VALVE & GATE VALVE BOX		
29a	0	EA.	REMOVE EXISTING HYDRANT, FURNISH & INSTALL NEW HYDRANT & 6"HYDRANT BRANCH		
29b	0	EA.	REMOVE AND REST EXISTING HYDRANT INCLUDING NEW 6"HYDRANT BRANCH		
30a	9	EA.	FURNISH & SET 3/4" CORPORATION COCK		
30b	0	EA.	FURNISH & SET 1" CORPORATION COCK		
30c	0	EA.	FURNISH & SET 2" CORPORATION COCK		
31a	9	EA.	FURNISH & SET 3/4 " CURB STOP & BOX		
31b	0	EA.	FURNISH & SET 1 " CURB STOP & BOX		

31c	0	EA.	FURNISH & SET 2 " CURB STOP & BOX		
32a	225	L.F.	FURNISH & INSTALL 3/4" COPPER SERVICE PIPE & FITTINGS		
32b	0	L.F.	FURNISH & INSTALL 1" COPPER SERVICE PIPE & FITTINGS		
32c	0	L.F.	FURNISH & INSTALL 2" COPPER SERVICE PIPE & FITTINGS		
33	10	C.Y.	TRENCH ROCK EXCAVATION		
34	10	C.Y.	MISCELLANEOUS TRENCH EXCAVATION		
35	750	C.Y.	UNSUITABLE TRENCH MATERIAL		
36	15	L.F.	REMOVAL, DISPOSAL, & HANDLING OF EXISTING TRANSITE PIPE		
Bid Alt. #2 Subtotal					
Base Bid + Bid Alt. #1 + Bid Alt. #2					

BID SUMMARY

Base Bid – Bow Street & Mill Street

Total in Figures: _____

Total in Words: _____

Base Bid + Bid Alt. #1 – Bow Street, Mill Street, & Spring Street

Total in Figures: _____

Total in Words: _____

Base Bid + Bid Alt. #1 + Bid Alt. #2 – Bow Street, Mill Street, Spring Street, & Burch Street

Total in Figures: _____

Total in Words: _____

The above estimated quantities are an approximate statement of the extent of the work to be done; the Town does not expressly or by implication agree that the actual amount of work will correspond therewith but reserves the right to increase or decrease the amount of any class or portion of the work or to delete certain items of work, as may be deemed necessary, to keep within available funds.

The undersigned as bidder, agrees that for extra work, if any, s/he will accept compensation as stipulated in the annexed form of CONTRACT.

If this proposal shall be accepted by the Town, and the undersigned shall fail to execute the contract for the work and deliver same to the Town, together with the duly executed Performance Bond and Labor and Material Payment Bond, with sureties satisfactory to the Town, within ten (10) days from the date of mailing of a notice from the Town to her/him at the address herein given that the proposed contract is ready for execution, then the Town at its option may determine that the undersigned has abandoned the said contract and thereupon if it so determines, the bid security accompanying this proposal shall become the property of the Town as liquidated damages; otherwise the accompanying security shall be returned to the undersigned.

All bidders will be required to show that they have previously completed projects of the same type in a satisfactory manner, namely, the removal of existing water mains and the installation of new water mains in residential, commercial, and/or otherwise confined areas congested with numerous structures, conduits, high voltage-oil filled electric pipe lines, public and private utility lines, manholes, etc., where careful and time consuming excavation and backfilling is required to protect existing lines and structures.

The bidder awarded this contract will have to show that they have successfully completed at least three (3) contracts of similar work at a value of \$750,000 or more in the previous five (5) years.

In addition, if the successful bidder contemplates using sub-contractors, said sub-contractor will be held to the same standards as noted above.

Before starting work, the contractors (includes the general contractor, for itself and its subcontractors, as well as all filed sub-bid contractors) will submit plans for achievement of the equal opportunity goals of the contract. All contractors will be required to make a good faith effort to achieve these goals. The plan will indicate if the contractors expect to achieve the requirements during the first quarter. If there are any reasons why the contractors do not expect to achieve the requirements during the first quarter year of the contract construction phase, then the contractors shall provide a plan calculated to address, to the extent reasonably possible, these obstacles to a good faith effort to achieve such goals.

Not more than ten days following the end of each work quarter, the contractors will report on the achievement of the goals, the detailing the good faith efforts that have been made and will continue to be made and any other appropriate efforts not yet undertaken.

All reports will be signed by an officer or principal of the company who has the authority to contractually obligate the company.

The contractor shall maintain as a goal on this project a not less than five percent ratio of women work force to total project hours in both the general contract and each individual filed sub-bid contract.

A Labor Scheduling Table which will be used as a tool for achieving a range of women work force participation for the entire project in both the general contract and each individual filed sub-bid contractor.

Signature of bidders, with residence and business address. If the bidder can give the name and address of the surety company that will sign the bonds or state the other security to be offered, s/he is requested to do so below.

A. Financial Statement

The bidder is required to furnish a financial statement and give references that will enable the Town to judge her/his business standing.

B. Bidders Experience Record

The bidder is required to state below work s/he has done of a character similar to that work included in the proposed contract and give references that will enable the Town to judge her/his experience and skill.

Legislation enacted by the Commonwealth of Massachusetts, effective July 1, 1983 requires that the attestation below be signed:

C. Certification of Tax Compliance

Pursuant to MGL c. 62C, § 49A and requirements of the Town of Arlington, the undersigned acting on behalf of the Contractor certifies under the penalties of perjury that the Contractor is in compliance with all laws of the Commonwealth relating to taxes including payment of all local taxes, fees, assessments, betterments and any other local or municipal charges (unless the Contractor has a pending abatement application or has entered into a payment agreement with the entity to which such charges were owed), reporting of employees and contractors, and withholding and remitting child support.*

**Signature of Individual or Corporate Contractor

Printed Name

***Contractor's Social Security Number or
Federal Identification Number

Date

* The provision in this Certification relating to child support applies only when the Contractor is an individual.

** Approval of a contract or other agreement will not be granted until the City receives a signed copy of this Certification.

*** Your social security number may be furnished to the Massachusetts Department of Revenue to determine whether you have met tax filing or tax payment obligations. Providers who fail to correct their non-filing or delinquency will not have a contract or other agreement issued, renewed, or extended.

D. CERTIFICATE OF NON-COLLUSION

The undersigned certifies under penalties of perjury that this bid or proposal has been made and submitted in good faith and submitted in good faith and without collusion or fraud with any other person. As used in this certification, the word “person” shall mean any natural person, business, partnership, corporation, union, committee club, or other organization, entity, or group or individuals.

(Signature of individual)

(Name of Business/Corporation)

IV. Contract

A. Definitions

Wherever the word “Town”, “Contractor”, or “Engineer” or pronouns used in place of them occur in this contract, they shall have the following meanings:

The word “Town” shall mean the party of the first part above designated, or any board, office, or agent duly authorized to act for said party of the first part in the matter covered by this contract.

The word “Contractor” shall mean the party of the second part above designated entering into this contract for the performance of the work required, the legal representative of said party, or the agent appointed to act for said party in performance of the work.

The word “Engineer” shall mean the Town Engineer of the Town of Arlington, acting directly or through an authorized representative, acting within the scope of the particular duties entrusted to him.

B. Parts of Contract

It is agreed that the Information for Bidders, the Proposal submitted by the Contractor, the General Conditions, the Special Conditions, the Specifications, the Contract Drawings/Plans, and all Addenda are made parts of this contract.

The table of contents, titles, indexes, and headings contained herein and in said documents are solely to facilitate reference to various provisions of the Contract Documents and in no way affect, limit or cast light on the interpretation of the provisions to which they refer.

C. Obligations of the Contractor

The Contractor shall do all the work and furnish all services, tools, equipment, appliances, and labor necessary, and furnish all materials except as may be otherwise specified herein, necessary or proper for performing and completing the work required by this Contract, with appurtenances of every kind complete in the manner and within the time specified. All work to be performed and materials to be furnished under this contract shall be performed, furnished and completed pursuant to and strictly in conformance with the Contract Drawings, sometimes referred to herein as the “plans”, the attached specifications, and the written directions of the Engineer as given from time to time during the progress of the work. The Contractor shall complete the entire work in accordance with the specifications and drawings herein mentioned and at the prices herein agreed upon and therefore fixed.

D. Liability of the Contractor

The Contractor shall take all responsibility for the work done under this contract, for the protection of the work, and for preventing injuries to persons and damage to property and utilities on or about the work. S/he shall in no way be relieved of her/his responsibility by any right of the Engineer to give permission or directions relating to any part of the work, by any such permission or directions given, or by failure of the Engineer to give such permission or direction.

The Contractor shall bear all losses resulting to him or the Town on account of the quantity or character of the work, because the nature of the land in or on which the work

is done is different from what was estimated or expected, or on account of the weather, elements, or other causes.

The Contractor shall assume the defense of all claims of whatsoever character against the Contractor or the Town and indemnify and save harmless the Town, its officers, or agents against all claims for injury or damage to persons, corporations, or property arising out of the work done under this contract whether said claims arise out of negligence or not, or whether said claims are groundless, false, or fraudulent or not, and from all claims relating to labor and materials furnished for the work.

The Contractor shall conduct her/his operations so as not to damage existing structures or work installed either by her/him or by other contractors. In case of any such damage resulting from her/his operations, s/he shall repair and make good as new the damaged portions at her/his own expense with the consent of the damaged party. In the event that consent is not given, the Contractor shall not be relieved thereby of liability for the damage caused.

E. Authority of the Engineer

The Engineer shall have the authority to stop the work whenever such stoppage may be necessary in her/his opinion to prevent improper execution of the work.

The sequence of execution of the work and the general conduct of the work shall be subject to the approval of the Engineer who shall have authority to direct changes be made in such sequence where public necessity or welfare shall require, which approval or direction shall, however, in no way affect the responsibility of the Contractor in the conduct of the work.

Whenever the Contractor is not present on any part of the work where it may be necessary to give directions, such directions may be given by the Engineer and shall be received and obeyed by the superintendent or foreman who may have charge of the particular work involved.

F. Engineer to Decide

The Engineer shall make all necessary interpretations as to the meaning and intention of the Contract Drawings, Specifications, and other parts of this Contract. S/he shall give all orders and directions contemplated therein or thereby, and in every case in which a difficult or unforeseen condition shall arise in the performance of the work required by this contract.

The Engineer shall in all cases determine the amount, quality, acceptability and fitness of the several kinds of work and materials which are to be paid under this contract, and shall decide all questions which may arise as to the fulfillment of this contract. In the event that a determination or decision of the Engineer is questioned by the Contractor, the decision of the Engineer shall be a condition precedent to the Contractor's right to receive any money for the work or materials to which the question or difference in opinion relates.

G. Time for Commencing Work

The Contractor shall commence the work within thirty (30) calendar days after signing the contract, or as directed by the Town.

Such time of starting may be postponed by written agreement between the Town and the Contractor because of expected delays in receipt of materials and equipment, if the season is unsuitable for commencement of the work, or because of any other contingency clearly beyond the control or responsibility of the Contractor. Unless stipulated otherwise in said agreement, the Contractor shall commence work at such points as the Engineer may direct or approve within thirty (30) calendar days after the receipt of a written order from the Town to start work.

H. No Damages for Certain Delays

The Town may delay the commencement of the work, or any part thereof, for the reason that it has not acquired the necessary land or rights of way, or for any other reason. The Contractor shall have no claim for damages on account of such delay, or on account of any delay on the part of the Town in performing any work or furnishing any materials to the Contractor, or due to extra work required, but s/he shall be entitled to so much additional time in which to complete the whole or any portion of the work required under this contract. The Contractor shall have no claim for damages on account of any delay on the part of another contractor, but shall have such additional time in which to complete the work.

I. Time for Completion

The rate of progress shall be such that the whole work shall be performed in accordance with the terms of this contract before the expiration of the time limit stipulated under special conditions, unless and except as any part may be delayed under the provisions of this contract.

It is agreed that the rate of progress herein required has been purposely made long enough to allow for the ordinary delays incident to construction work of this character. No extension of time will be made for ordinary delays, inclement weather, and accidents, and the occurrence of such will not relieve the Contractor from the necessity of maintaining this rate of progress.

If delays are caused by acts of God, acts of Government or State, strikes, extra work, or other contingencies clearly beyond the control or responsibility of the Contractor, the Contractor shall be entitled to so much additional time wherein to perform and complete this contract on her/his part as the Engineer shall certify in writing to be just.*

*This paragraph will be interpreted to include delays in receipt of equipment provided that the Contractor placed her/his order and submitted shop drawings for such equipment promptly after execution of the contract, that s/he has shown diligence in following the progress of the order, and that the time required for delivery is in accordance with conditions generally prevailing in the industry.

The time in which this contract is to be performed and completed is of the essence of this agreement.

J. Competent Persons to be Employed

The Contractor shall have as her/his agent on the work a competent superintendent capable of reading and thoroughly understanding the drawings and specifications. The superintendent on the work shall have full authority to execute the directions of the Engineer without delay and supply promptly such materials, equipment, tools, labor, and incidentals as may be required.

The Contractor shall employ only competent women/men to do the work, and whenever the Engineer shall notify the Contractor in writing that any man on the work is, in her/his opinion, incompetent, unfaithful, disorderly or otherwise unsatisfactory, such man shall be discharged from the work and shall not again be employed on it except with the consent of the Engineer.

K. Access to Work

The Town, its agents and employees may at all times enter upon the work or premises used by the Contractor, and the Contractor shall provide safe and proper facilities for such entrance and for the inspection of materials, equipment and workmanship.

Other contractors of the Town may also, for the purpose which may be required by their contracts or work, enter upon the work and premises used by the Contractor. Any differences or conflicts which may arise between the Contractor and other contractors of the Town in regard to their work shall be determined and adjusted by the Engineer.

L. Defective Work, Materials or Equipment

The inspection of the work shall not relieve the Contractor or any of her/his obligations to fulfill her/his contract as herein prescribed, and defective work shall be made good and unsuitable materials or equipment shall be rejected, notwithstanding that such work, and materials or equipment have been previously overlooked by the Engineer and accepted or estimated for payment or paid for. If the work or any part thereof shall be found defective at any time before the final acceptance of the whole work, or the final payment therefore, the Contractor shall forthwith make good such defect, in a manner satisfactory to the Engineer; if any material or equipment brought upon the ground for use in the work, or selected for the same, shall be condemned by the Engineer as unsuitable or not in conformity with the specifications, the Contractor shall forthwith remove such materials or equipment from the vicinity of the work, and any material furnished by the Town which shall be damaged or rendered defective by the handling or improper installation by the Contractor, her/his agents, or employees shall be made good and replaced at the Contractor's own expense.

M. Mistakes of Contractor

The Contractor shall make good any defects, omissions, or mistakes for which s/he or her/his employees are responsible, or s/he shall pay to the Town all expenses, losses, and damages incurred therefrom as determined by the Engineer.

N. Discrepancies, Errors and Omissions

The drawings and specifications are intended to be explanatory of each other, but, should any discrepancy appear or any misunderstanding arise as to the import of anything contained in either, the interpretation and decision of the Engineer shall be final and binding on both parties to this contract.

Any correction of errors or omissions in drawings and specifications may be made by the Engineer when such correction is necessary for the proper fulfillment of their intention as construed by him. Where said correction of errors or omissions, except as provided in the next two paragraphs below, adds to the amount of work to be done by the Contractor, compensation for said additional work shall be made under the item for Extra Work, except where the additional work may be classed under some item of work for which a unit price is included in the PROPOSAL.

The fact that specific mention of a fixture or of any part of the work is omitted in the specifications, whether intentionally or otherwise, when the same is clearly indicated on the drawings, or is usually and customarily required to complete fully such work as is specified herein, will not entitle the Contractor to consideration in the matter of any claim for extra compensation, but said fixtures or work or both shall be installed or done the same as if called for both by the drawings and by the specifications.

All work mentioned in the specifications and not indicated on the drawings, or vice versa, and all work and material usual and necessary to make the work complete in all its parts, whether or not they are mentioned in the specifications, or indicated on the drawings, shall be furnished and executed the same as if they were called for both by the specifications and by the drawings.

O. Right to Materials

All materials shall become the property of the Town after they have been affixed or attached to the soil or to the work, and nothing in this contract shall be construed as vesting in the Contractor any right or property in the materials after their being so affixed or attached.

P. Compliance with Laws, Ordinances, and Regulations

The Contractor shall keep herself/himself fully informed of all existing and future State and National laws and municipal ordinances and regulations in any manner affecting those engaged or employed in the work, the materials used in the work, or the conduct of the work, and of all such orders and decrees of bodies or tribunals having any jurisdiction or authority over the same. If any discrepancy or inconsistency is discovered in the plans, drawings, specifications, or contract for this work, in relation to any such law, ordinance, regulation, order or decree, s/he shall forthwith report the same to the Engineer in writing. S/he shall at all times herself/himself observe and comply with, and cause all her/his agents and employees to observe and comply with, all such existing and future laws, ordinances, regulations, orders and decrees; and s/he shall protect and indemnify the Town, its officers, and agents against any claim or liability arising from or based upon violation of any such law, ordinance, regulation, order, or decree, whether by herself/himself or her/his employees.

Q. Provisions Required by Law Deemed Inserted

Each and every provision of law and clause required by law to be inserted in this contract shall be deemed to be inserted herein and the contract shall be read and enforced as though it were included herein, and if through mistake or otherwise any such provision is not inserted, or is not correctly inserted, then upon the application of either party the contract shall forthwith be physically amended to make such insertion or correction.

R. Work Hours

General work hours shall be as follows for Bow Street (Base Bid), Spring Street (Bid Alternate #1), and Burch Street (Bid Alternate #2):

- Monday - Friday from 7:00 AM - 5:00 PM.

Due to its close proximity to Arlington High School, work hours will generally be restricted as follows for Mill Street:

- Monday - Friday from 9:00 AM - 3:00 PM.

Work hours on Mill Street may be elongated between July 1st and August 31st at the discretion of the Arlington Police Department and the Arlington Engineering Division.

No work shall be done at night, on holidays, or on weekends except:

- 1) Usual protective work, such as pumping and the tending of lights and fires;
- 2) Work done in case of emergency threatening injury to persons or property;
- 3) If all of the conditions set forth in the next paragraph below are met.

No work other than that included in 1 and 2, above, shall be done at night, on holidays, or on weekends except when:

- a) In the opinion of the Engineer, the work will be of advantage to the Town and can be performed satisfactorily at night;
- b) The work shall be done by a crew organized for regular and continuous night work;
- c) The Engineer has given written permission for such night work.

S. Intoxicating Liquors

The contractor shall not sell and shall neither permit nor suffer the sale, the introduction of, or the use of intoxicating liquors upon or about the work under this contract.

T. Permits and Notices

The Contractor shall, at her/his own expense, take out all necessary permits from the county, municipality, or other public authorities; shall give all notices required by law or ordinances; and shall post all bonds and pay all fees and charges incident to the due and lawful prosecution of the work covered by this contract.

U. Patents

The Contractor shall indemnify and save harmless the Town and all persons acting for or on behalf of the Town from all claims and liability of any nature or kind, including costs and expenses, arising from or occasioned by any infringement or alleged infringement of patent rights on any invention process, article, or apparatus, or any part thereof, furnished and installed by said Contractor or arising from or occasioned by the use of manufacture thereof, including their use by the Town.

V. Insurance

The Contractor shall not commence work under this contract until s/he has obtained all the insurance required under this paragraph and such insurance has been approved by the Town, nor shall the Contractor allow any subcontractor to commence work on her/his subcontract until the insurance required of the subcontractor has been so obtained and approved.

- A. Compensation Insurance: The Contractor shall procure and shall maintain during the life of this contract Workmen's Compensation Insurance as required by applicable State or territorial law for all of her/his employees to be engaged in work at the site of the project under this contract and, in case of any such work sublet, the Contractor shall require the subcontractor similarly to provide Workmen's Compensation Insurance for all of the latter's employees to be engaged in such work unless such

employees are covered by the protection afforded by the Contractor's Workmen's Compensation Insurance. In case any class of employees engage in hazardous work on the project under this contract is not protected under the Workmen's Compensation Statue, the Contractor shall provide adequate employer's liability insurance for the protection of such of her/his employees as are not otherwise protected.

- B. Contractor's Public Liability and Property Damage Insurance: The Contractor shall maintain during the life of this contract Contractor's Public Liability Insurance and Contractor's Property Damage Insurance to the limits specified under SPECIAL CONDITIONS.
- C. Subcontractor's Public Liability and Property Damage Insurance: The Contractor shall either (1) require each of her/his subcontractors to procure and to maintain during the life of her/his sub-contract, Subcontractor's Public Liability and Property Damage Insurance of the type and to the limits specified under SPECIAL CONDITIONS or, (2) insure the activities of her/his subcontractors in her/his policy, specified in subparagraph (b) hereof.
- D. Scope of Insurance: The insurance required under sub-paragraphs (b) and (c) hereof shall provide adequate protection for the Contractor and her/his subcontractors, respectively, against damage claims which may arise from operations under this contract, whether such operations be by the insured or by anyone directly or indirectly employed by him.
- E. Proof of Carriage of Insurance: The Contractor shall furnish the Town with certificates showing the type, amount, class of operations covered, effective dates and dates of expiration of policies. Such certificates shall also contain substantially the following statement: "The insurance covered by this certificate will not be cancelled or materially altered, except after fifteen (15) days written notice has been received by the Town." If the initial insurance expires prior to completion of the work, renewal certificates shall be furnished by the date of expiration.

W. Work Not to be Sublet or Assigned

The Contractor shall give her/his personal attention constantly to the faithful prosecution of the work, shall keep the same under her/his personal control, and shall not assign by power of attorney or otherwise, or sublet the work or any part thereof without the previous written consent of the Town, and shall not, either legally or equitably, assign any of the moneys payable under this agreement, or her/his claim thereto, unless by and with the like consent of the Town and the Surety on the Bonds.

X. Alterations

The Engineer may by written order, and not otherwise, make alterations in the line, grade, plan, form, dimension or materials of the work, or any part thereof, either before or after the commencement of construction. If such alterations make the work less expensive to the Contractor, a proper deduction shall be made from the contract price, said deduction to be computed on the same basis as that specified under Extra Work for determining the value of approved extra work, unless there be applicable unit prices established by this contract, in which event the unit prices shall prevail.

The Contractor shall have no claims for damages or for anticipated profits on the work that thus may be dispensed with. (If such alterations make the work more expensive, a

proper addition computed in the aforementioned manner shall be made to the contract price. Any such deduction or addition shall be determined by the Engineer.)

Y. Extra Work

The Contractor shall do any work not herein otherwise provided for, when and as ordered in writing by the Town or her/his agents specially authorized thereto in writing, and shall, when requested by the Town so to do, furnish itemized statements of the cost of the work ordered and give the Town access to accounts, bills and vouchers relating thereto.

If the Contractor claims compensation for extra work not ordered as aforesaid, or for any damage sustained, s/he shall within one week after the beginning of any such work or of the sustaining of any such damage, make a written statement of the nature of the work performed or damage sustained, to the Town and shall on or before the fifteenth day of the month succeeding that in which any such extra work shall have been done or any such damage shall have been sustained, file with the Town an itemized statement of the details and amount of such work or damage: and unless such statements shall be made as so required, her/his claim for compensation shall be void, and s/he shall not be entitled to payment on account of any such work or damage. The Contractor shall not include in the cost of extra work any cost or rental of small tools, buildings, or any portion of the time of the Contractor, her/his superintendent, or her/his office and engineering staff.

In the alternative, the extra work order may provide that the Contractor shall receive an amount equal to the actual cost of such extra work computed on the basis of the foregoing sub-sections (a) through (g) but limited by a predetermined lump sum maximum amount.

The determination of the Town shall be final upon all questions of the amount and value of extra work, provided that such extra work has been performed under a work order approved in writing by the Town as required by the terms of this contract.

The Town shall pay and the Contractor shall receive for everything furnished and done by the Contractor to the satisfaction of the Town under an approved extra work order a predetermined lump sum amount computed on the basis of the following:

- A. the actual cost of labor employed directly on the work at prevailing rates of wages.
- B. the cost of the amounts of additional premium paid on the required insurance on account of such extra work, of Social Security or other direct assessments upon the Contractor's payroll by Federal or other properly authorized public agencies, and of other approved assessments when such assessments are not normally included in payments made by the Contractor directly to her/his employees, but are recognized to be part of the cost of doing work.
- C. the reasonable cost of materials incorporated in the work.
- D. the reasonable cost at fair market rental rates for equipment employed directly on the work.
- E. 15% of (a) (b) (c) and (d) for overhead and profit. (On subcontract work, this 15% will be allowed only to the subcontractor).
- F. an additional 5% of (a) (b) (c) (d) and (e) on work performed by a subcontractor of the Contractor.

Z. Extension of Time on Account of Extra Work

When extra work is ordered near the completion of the contract or when extra work is ordered at any time during the progress of the work which requires in the opinion of the Engineer an unavoidable increase of time for the completion of the contract, a suitable extension of the time for completion shall be made.

AA. Changes Not to Affect Bonds

It is agreed and understood that any changes made in the drawings and specifications for this work (whether such changes increase or decrease the amount thereof) or any change in the manner or time of payments made by the Town to the Contractor shall in no way annul, release, or affect the liability and surety on the bonds given by the Contractor.

BB. Completion of Work if Contract is Not Fulfilled

If the Contractor shall be adjudged bankrupt, or if s/he shall make a general assignment for the benefit of her/his creditors, or if a receiver shall be appointed of her/his property, or if the work to be done under this contract shall be abandoned, or if this contract or any part thereof shall be sublet without the previous written consent of the Town, or if the contract or any claim thereunder shall be assigned by the Contractor otherwise than as herein specified, or if at any time the Engineer shall be of the opinion, and shall so certify in writing to the Town that the conditions herein specified as to the rate of progress are not fulfilled, or that the work, or any part thereof, is unnecessarily or unreasonably delayed, or that the Contractor has violated any of the provisions of this contract, the Town may terminate the contract and hold the Contractor and her/his sureties liable in damages as for a breach of contract by an abandonment thereof by him, or the Town may notify the Contractor to discontinue all work, or any part thereof; and thereupon the Contractor shall discontinue all work, or any part thereof, as the Town may designate and the Town may thereupon, by contract or otherwise, as it may determine, complete the work, or such part thereof, and charge the entire expense for so completing the work, or part thereof, to the Contractor: and for such completion the Town, for itself or its contractors, may take possession of and use or cause to be used in the completion of the work or part thereof any of such materials, machinery, implements and tools of every description as may be found upon the line of said work. The Town may, at its option, require the surety or sureties to complete the contract. The Town shall not be liable for any depreciation, loss or damage to said materials, machinery, implements or tools during said use, nor until such as are not incorporated in the work are removed by the Contractor after completion of the work. Unless so removed within fifteen days after mailing of notice so to do, they may be sold at public auction, after publication of notice thereof at least twice in any newspaper published in the county where the work is being performed, and the proceeds credited to the Contractor's account; or they may, at the option of the Town, be stored at the Contractor's expense subject to a lien for the storage charges.

If the Engineer shall certify as aforesaid as to the rate of progress, the Town may, instead of notifying the Contractor to discontinue all work or any part thereof, notify him from time to time to increase the work force, equipment and plant, or any of them, employed on the whole or any part of the work, stating the amount of increase required; and unless s/he shall, within five days after any such notice, increase her/his force, equipment and plant to the extent required therein, and maintain and employ the same from day to day until the condition as to the rate of progress shall, in the opinion of the Engineer, be fulfilled, the Town may employ and direct the labors of such additional force, equipment

and plant as may, in the opinion of the Engineer, be necessary to insure the completion of the work or such part thereof within the time herein specified, or at the earliest possible date thereafter, and charge the expense thereof to the Contractor. Neither the notice from the Town to the Contractor to increase her/his force, equipment or plant, nor the employment of additional force, equipment or plant by the Town shall be held to prevent a subsequent notice from the Town to him to discontinue work under the provisions of the preceding portion of this section.

All expenses charged under this section shall be deducted and paid by the Town out of any moneys then due or to become due the Contractor under this contract, or any part thereof; and in such accounting the Town shall not be held to obtain the lowest figures for the work of completing the contract or any part thereof, or for ensuring its proper completion, or for the additional force, equipment or plant that may be employed, but all sums actually paid therefore shall be charged to the Contractor. In case the expenses so charged exceed the sum that would have been payable under this contract if the same had been completed by the Contractor, the Contractor shall pay the amount of the excess to the Town, upon completion of the work, without further demand being made therefore.

CC. Compensation for Work

The Town shall pay, and the Contractor shall receive, the prices stipulated in the Proposal attached hereto as full compensation for everything furnished and done by the Contractor under this contract, including all work required but not specifically mentioned, and also for all loss or damage arising out of the nature of the work aforesaid, or from the action of the elements, or from any unforeseen obstruction or difficulty encountered in the prosecution of the work, and for all risks of every description connected with the work, and for all expenses incurred by or in consequence of the suspension or discontinuance of the work as herein specified and for well and faithfully completing the work, and the whole thereof, as herein provided.

DD. Money may be Retained

The Town may keep any money which would otherwise be payable at any time hereunder; may apply the same or so much as may be necessary therefore to the payment of any expenses, losses, or damages incurred by the Town and determined as herein provided; and may retain, until all claims are settled, so much of such money as the Town is of the opinion will be required to settle all claims filed with the Town, its officers, and agent relating to this contract.

EE. Estimates and Payments

The Engineer shall, on or about the first day of each month, except as hereinafter provided, make an estimate in writing of the total amount and value of the work done to the first of the month by the Contractor. The Town shall retain a percentage of such estimated value, as set forth under SPECIAL CONDITIONS, as part security for fulfillment of this contract by the Contractor and shall deduct from the balance all previous payments and all sums to be retained under the provisions of this contract. The Town shall pay monthly to the Contractor the balance not retained as aforesaid, except that payment may be withheld at any time if the work is not proceeding in accordance with the contract. The Town may cause estimates and payments to be made more frequently than once in each month.

Estimates of lump-sum items shall be based on a schedule dividing each item into its appropriate component parts together with a quantity and a unit price for each part such that the sum of the products or prices and quantities will equal the contract price for the item. This schedule shall be submitted by the Contractor for the approval of the Engineer before the first estimate becomes due.

If the Engineer determines that the progress of the work will be benefited by the delivery to the site of certain materials and equipment, when available, in advance of actual requirement therefore and if such materials and equipment are delivered and properly stored and protected, the cost to the Contractor or subcontractor as established by invoices or other suitable vouchers may be included in the estimates.

The Engineer shall, as soon as practicable (but not more than 65 days) after the completion of the work under this contract, make a final estimate in writing of the quantity of work done under the contract and the amount earned by the Contractor. The Engineer also shall fix the date of completion of said work and incorporate the same into final estimate.

The Town shall pay to the Contractor the entire sum found to be due hereunder after deducting therefrom all previous payments, all amounts to be kept, and all amount to be retained under the provisions of this contract. Such payment shall be made not later than 15 days after, but in no event before the expiration of the time within which claims for labor performed and materials used or employed must be entered under the Lien Law, or, if such time is not specified by law, the expiration of 30 days after the completion of the final estimate.

All quantities shown on progress estimates and all prior payments shall be subject to correction in the final estimate and payment.

FF. Partial Payment Not Acceptance

It is agreed that this is an entire contract for one whole and complete work and that no partial payments on account by the Town nor the use of parts of the proposed equipment shall constitute an acceptance of any part of the work before its entire completion and final acceptance.

GG. Liens

If at any time before the expiration of the period within which claims must be entered under the Lien Law, or if not otherwise specified by law, within 30 days after the whole work herein agreed to be delivered have been performed, delivered, or completed and accepted by the Town, any person or persons claiming to have performed any labor or furnished any materials toward the performance or completion of this contract shall file with the Town suitable notice, the Town shall retain, until the discharge thereof, from the moneys under its control so much of such money as sufficient to satisfy and discharge the amount claimed to be due in such notice, together with the cost of any action or actions brought to enforce such lien created by the filing of such notice.

HH. Waiver

Neither the inspection by the Engineer, nor any act of thing done by the Town or its agents other than an express waiver by vote of the Town shall operate as a waiver of any provision of this contract; nor shall any waiver of any breach of this contract be held to be a waiver of any other subsequent breach. Any remedy provided in this contract shall

be taken and construed as cumulative; that is in addition to each and every other remedy herein provided.

II. Liability of the Town of Arlington

No person, firm, or corporation, other than the signer of this contract as Contractor, now have any interest hereunder; no claim shall be made or be valid; and neither the Town nor any agent of the Town shall be liable for or be held to pay any money, except as herein provided. The acceptance by the Contractor of the payment of the final estimate shall operate as and shall be a release to the Town and every agent of the Town from all claim and liability to the Contractor for anything done or furnished for or relating to the work or for any act or neglect of the Town or of any person relating to or affecting the work, except the claim against the Town for the remainder, if there is any, of the amounts kept or retained as herein provided.

JJ. Guarantee

The Contractor guarantees that the work to be done under this contract, and the workmanship performed and the materials and equipment used in the construction of the same, shall be free from defects or flaws, that each item of equipment shall be in accordance with the specifications, that the strength of all parts of all manufactured equipment shall be adequate and that the performance test requirements of the specifications shall be fulfilled. This guarantee shall be for a period of one year from and after the date of completion of the work as stated in the final estimate. The Contractor shall repair or replace as required, promptly and without charge, all work, equipment, and material, or parts thereof, which fail to meet the above guarantee during one year herein quoted.

It is hereby, however, agreed and understood that this guarantee shall not include any repairs or replacements made necessary by any cause or causes other than improper, inadequate, or defective work, workmanship, materials, or design by the Contractor or those employed directly or indirectly by him.

KK. Money Retained for Repairs

The Town may retain out of the monies payable to the Contractor under the contract a sum as set for under SPECIAL CONDITIONS and may expend the same, in the manner hereinafter provided, in making such repairs or replacements of said work as the Town may deem expedient.

If at any time within the said period of guarantee any part of the work constructed under the terms of this contract requires repairing or replacement, the Town may notify the Contractor in writing to make the required repairs or replacements. If the Contractor neglects to make such repairs or replacements to the satisfaction of the Town within ten (10) days from the date of receipt of such notice, the Town may employ other persons to make the same. The Town shall pay the expense of the same out of the sum retained for that purpose. Upon expiration of the said period of guarantee, provided that the work at the time is in good order, the Contractor will be entitled to receive the whole or such part of the sum last aforesaid as may remain after the expense of making said repairs or replacements, in the manner aforesaid, has been paid therefrom.

It is agreed that the Town may keep the whole or any portion of the sum retained for settlement of all claims arising out of this contract against the Town, its officers, or

agents and for all expenses, losses, or damages incurred by the Town by reason of said claims.

LL. Address of Contractor

The Contractor's business address and her/his office at or near the site of the work are both hereby designated as places to which communications shall be delivered. The depositing of any letter, notice, or other communication in a postpaid wrapper directed to the Contractor's business address in a post office box regularly maintained by the Post Office Department or the delivery at either designated address of any letter, notice, or other communication by mail or otherwise shall be deemed sufficient service thereof upon the Contractor. The first-named address may be changed at any time by an instrument in writing, executed and acknowledged by the Contractor and delivered to the Engineer. Nothing herein contained shall be deemed to preclude or render inoperative the service of any notice, letter, or other communication upon the Contractor personally.

MM. CERTIFICATE of VOTE

I, _____, Clerk of _____,
(Name) (Corporation)

hereby certify that, at a meeting of the Board of directors of said Corporation duly held on _____ at which a quorum was present and
(Date)

voting throughout, the following vote was duly passed is now in full force and effect:

“VOTED” That _____
(Name of Officer authorized to sign for corporation)

be and hereby is authorized, directed and empowered for, in the name and on behalf of this Corporation, to sign, seal with the corporate seal, execute, acknowledge and deliver all contracts, bonds and other obligations of this Corporation; by such

(Name of Officer)

to be valid and binding upon this Corporation for all purposes, and that a certificate of the Clerk of this Corporation setting forth this vote shall be delivered to the Town of Arlington; and that this vote shall remain in full force and effect unless and until the same has been altered, amended or revoked by a subsequent vote of such directors and a certificate of such later vote attested by the Clerk of this Corporation is delivered to the Town of Arlington.

I further certify that _____ is the duly
(Name of Officer)
elected _____ of said Corporation.
(Title)

Signed: _____
(Clerk - Secretary)

Place of Business: _____

Date of Contract: _____

AFFIX COPORATE SEAL

COUNTERSIGNATURE: _____
(Name & Title of Officer)

In the event that the Clerk or Secretary is the same person as the Officer authorized to sign that contract or other instrument for the Corporation, this certificate must be countersigned by another officer of the Corporation.

V. PERFORMANCE BOND

KNOW BY ALL MEN BY THESE PRESENTS, that _____
as principal, and as surety, are held and firmly bound unto the Town of Arlington, Massachusetts
in the sum of _____
lawful money of the United States of America, to be paid to the Town of Arlington,
Massachusetts, for which payments, well and truly to be made, we bind ourselves, our respective
heirs, executors, administrators, successors and assigns, jointly and severally, firmly by these
presents.

WHEREAS, the said principal has made contract with the Town of Arlington bearing
_____ date of _____ 2017.

Now the condition of this obligation is such that if the principal shall well and truly keep and
perform all the undertakings, covenants, agreements, terms and conditions of said contract on its
part to be kept and performed during the original term of said contract and any extensions thereof
that may be granted by the Owner, with or without notice to the surety, and during the life of any
guaranty required under the contract and shall also well and truly keep and perform all the
undertakings, covenants, agreements, terms and conditions of any and all duly authorized
modifications, alterations, changes or additions to said contract that may hereafter be made,
notice to the surety of such modifications, alterations, changes or additions being hereby waived,
then this obligation shall become null and void; otherwise it shall remain in full force and virtue.

In the event that the contract is abandoned by the Contractor, or is terminated by the Owner,
under the provisions of “C.29 – Completion of Work if Contract is not Fulfilled” in SECTION C-
CONTRACT, said surety hereby further agrees that said surety shall, if requested in writing by
Owner, complete said contract.

IN WITNESS WHEREOF we hereunto set our hands and seals this _____ day
of _____ 2017.

_____ SEAL

_____ SEAL

_____ PRINCIPAL

_____ SEAL

_____ SURETY

KNOW BY ALL MEN BY THESE PRESENTS, that _____
as principals, and _____
as surety are held and firmly bound unto the Town of Arlington, in the sum of
_____ lawful money of the United States of America, to be paid
to the Town of Arlington, for which payments, well and truly to be made, we bind ourselves, our
respective heirs, executors, administrators, successors and assigns, jointly and severally, firmly by these
presents.

WHEREAS, the said principal has made contract with the Town of Arlington bearing _____
date of _____ 2017.

Now the condition of this obligation is such that if the principal shall pay for all labor performed or
furnished and for all materials used or employed in said contract and in any and all duly authorized
modifications, alterations, extensions of time, changes or additions to said contract that may hereafter be
made, notice to the surety of such modifications, alterations, extensions of time, changes or additions
being hereby waived, the foregoing to include any other purposes or items set out in, and to be subject to,
the provisions of Massachusetts General Laws (Ter. Ed.), Chapter 30, Section 39A as amended and
Chapter 149, Section 29 as amended, then this obligation shall become null and void; otherwise it shall
remain in full force and virtue.

IN WITNESS WHEREOF we hereunto set our hands and seals this _____ day
of _____ 2017.

_____ SEAL
_____ SEAL
_____ PRINCIPAL
_____ SEAL
_____ SURETY

VI. General Conditions

A. Definitions

The words “directed”, “required”, “permitted”, “ordered”, “designated”, “prescribed”, or words to like import shall mean the directions, requirement, permission, order, designation, prescription, etc. of the Engineer and similarly the words “approved”, “acceptable”, or “satisfactory”, or words of like import shall mean approved by or acceptable or satisfactory to, the Engineer, subject in each case to the final determination of the Town unless otherwise expressly stated.

The word “rock” wherever used as the name of material excavated or to be excavated, shall mean the sound bedrock, properly removed by blasting, wedging or barring, also such boulders exceeding three-quarters of a cubic yard in volume removed from the excavations, also any portions of existing masonry structures removed from the excavations. Sound bedrock shall not include any rock disintegrated or fractured, in the opinion of the Engineer, to such an extent as to be easily removable by pick and shovel. The word “boulders” as used above shall include loose, detached fragments or portions of ledge and only such fragments or portions as exceed the specified three-quarters of a cubic yard limit shall be included in the classification of “rock”.

The word “earth” wherever used as the name of an excavated material or material to be excavated, shall mean all kinds of material not defined as “rock” in the above paragraph.

B. Abbreviations

Wherever in the specifications, or on the drawings, any of the abbreviations which follow are used they shall have the following meaning:

AASHO	- American Association of State Highway Officials
ACI	- American Concrete Institute
AIEE	- American Institute of Electrical Engineers
AISC	- American Institute of Steel Construction
ASA	- American Standards Association
ASCE	- American Society of Civil Engineers
ASH&AE	- American Society of Heating and Air Conditioning Engineers
ASME	- American Society of Mechanical Engineers
ASTM	- American Society for Testing Materials
AWWA	- American Water Works Association
NBS	- National Bureau of Standards
NEC	- National Electrical Code, latest edition
NEMA	- National Electrical Manufacturers Association
Federal Specifications	- Federal Specifications issued by the Federal Supply Service of the General Service Administration, Washington, D.C.
125-lb. American Standard	- American Standard for Cast Iron Pipe Flanges and Flanged Fittings, Class 124 (ASA B16.1-1960)
O. S. & Y.	- Outside screw and yoke

C. Handling Materials

The Contractor shall at her/his own expense handle, haul and distribute all materials and equipment used and employed on the different portions of the works as required. Storage charges and demurrage charges by vendors and transportation companies, which result from delays in handling, shall be borne by the Contractor.

D. Storage Room

The Contractor shall provide suitable and adequate storage room for all materials during the progress of the work, and shall obtain the consent of the proper parties before entering or occupying with women/men, tools, or materials, any private land outside of the property or rights of way of the Town.

E. Shop Drawings, Schedules, and Descriptive Matter

The Contractor shall furnish, as hereinafter required, all specified shop and details drawings. All drawings required shall be submitted in triplicate to the Engineer for review and in quadruplicate after review.

The review by the Engineer of such drawings and details will be general and shall not relieve the Contractor of the responsibility for executing the entire work in accordance with the specifications and contract drawings. [Failure on the part of the Engineer to detect errors or omissions on shop drawings shall not relieve the Contractor from the responsibility for such errors or omissions.]

Should the contractor submit for review equipment that requires modifications to the structures, piping, layout, etc. detailed on the contract drawings, s/he shall also submit for review details of the proposed modifications. If such equipment and modifications are allowed, the Contractor, at no additional cost to the Town, shall do all work necessary to make such modifications.

The Contractor shall also furnish for the Engineer's review, all lists, schedules, and information regarding materials, fixtures and equipment as hereinafter required and specified.

All such lists, schedules, etc., shall be submitted to the Engineer for reviews within fifteen (15) days following execution of the contract. Following review by the Engineer of such materials, fixtures, and equipment, the Contractor shall promptly place orders for the equipment. Order shall be placed within seven (7) days following the Engineer's review and proof of such order shall be furnished to the Engineer.

F. Equivalents

Whenever the specifications define the material or article required by using the name of a proprietary product or of a manufacturer or vendor rather than by using descriptive detail of substance and functions, the words "or equivalent" are to be understood to follow immediately the make of the maker, vendor or proprietary product. The words "or equivalent" shall be interpreted as including any material or article which, in the opinion of the Engineer, is equivalent in quality, durability, appearance, strength and design to the article named and which will perform adequately the functions imposed by the general design.

Whenever in the specifications the names of manufacturers are mentioned as indicating that their products will comply with a particular specification, or when specific trade names or plated numbers or letters are mentioned, it is not intended to exclude products of other manufacturers whose names, trade names or symbols have not been mentioned, provided

however, that such products otherwise comply, in the opinion of the Engineer, with the specifications. The Engineer's opinion in all cases mentioned in this section shall be final.

G. Materials and Workmanship

All materials and equipment furnished under this contract shall be of standard high-grade quality and of the best workmanship and design. No inferior or low-grade materials will be accepted, and all work must be done in a neat, first-class and workmanlike manner.

The Engineer shall have the right to test and inspect or require certificates of tests of any materials to be used in the work.

H. Inspection by the Engineer

All materials and equipment furnished and work done by the Contractor shall be subject to inspection by the Engineer, and defective materials shall be removed from the site of the work and defective work repaired or replaced as directed. Facilities for inspection of the work shall at all times be furnished by the Contractor.

I. Documents at Site of Work

The Contractor shall have available at all times, at the site of the work, copies of the contract documents, any plans and all standard specifications of the various associations which are referred to in the specifications.

J. Lines and Grades

The Engineer shall establish such control stations, base lines and bench marks as may be necessary for the use of the Contractor. It shall be the specific duty of the Contractor to preserve and to protect the control base lines and bench marks so established.

During construction, the Contractor shall use the control stations, base lines and bench marks established by the Engineer to develop her/his own lines and grades as needed to comply with those specified or shown on the drawings. The Contractor shall be held responsible for all lines and grades which s/he has developed.

K. Scaffolding and Protection

The Contractor shall provide safe scaffolding to accommodate the work as applicable. S/he shall build all necessary runways, temporary stairs, ladders, barricades, fences, etc.

L. Public Safety and Property of Others

The Contractor shall make all necessary provisions to protect the public safety, and maintain and protect existing structures of whatever kind, and shall repair all damage done to such structures. S/he shall give ample notification to the proper officials of any city or town, of any public utility, corporation, or other individual before entering upon their respective public ways or rights of way and shall conform to the customary regulations and requirements of said officials, corporations, or individuals.

Extra precautions must be taken to avoid splattering adjoining property, automobiles, or structures. The Contractor shall be fully responsible for all damages to same.

M. Existing Structures, Pipes, Conduits, Etc.

As far as they are known, existing structures, pipes, conduits, etc. are shown on the drawings. Any existing structures, pipes, conduits, wires, etc., whether shown on the drawings or not shall be protected and if damaged shall be repaired by the Contractor without additional compensation.

Tie cards/Record Drawings of water, sewer, & drain mains/services within the work limits are provided as an appendix to these specifications. The contractor shall be responsible for marking out these utility locations in the field. In the absence of a tie card, the Town will assist in locating the service.

N. Sanitary Provisions

The Contractor shall provide and maintain in a neat and sanitary condition such accommodations for the use of her/his employees as may be necessary to comply with the requirements of the State Department of Public Health, local health officials, or other authorities having jurisdiction.

Every precaution shall be taken to prevent contamination or pollution of the ground at the site, or of any material or equipment which is to be incorporated in, or used in the construction of any work under this contract.

O. Cutting and Patching

The Contractor shall do all cutting, patching, drilling, grouting, etc., as necessary to complete the work, whether such work is described in the specifications or not.

P. Debris

Debris shall not be permitted to accumulate but shall be removed from the site of the work and disposed of by the Contractor.

Q. Measurement of Quantities

For the estimating of quantities in which the computation of areas by analytic and geometric methods would be comparatively laborious, it is stipulated and agreed that the planimeter shall be considered an instrument of precision adapted to the measurement of such areas.

For the purposes of measurement and computation of irregular volumes, the prismoidal formula shall be deemed a method of precision.

R. Compliance with Occupational Safety and Health Act of 1970

The Contractor shall in the work of this contract comply with all pertinent standards and regulations established by the Occupational Safety and Health Administration, Department of Labor by the authority of the Williams-Steiger Occupational Safety and Health Act of 1970. This project is subject to all of the Safety and Health Regulations (see 29 CFR 1518) as promulgated by the U.S. Department of Labor on April 17, 1971. Contractors are urged to make themselves familiar with the requirements of these regulations.

S. Order of Precedence Governing Specifications

The Standard Specifications for Highways and Bridges of the Commonwealth of Massachusetts, 1988 Edition plus any supplements shall be considered a part of these specifications.

In case of conflict between any sections of these specifications, plans, etc., the following order of precedence shall govern.

1. Special Provisions
2. Plans, Profiles, or Sections
3. Standard Specifications for Construction work in Arlington
4. Standard Specifications, 1988 Edition plus Supplements, for Highways and Bridges of the Commonwealth of Massachusetts.

T. Affirmative Action/Anti-Discrimination

For the purposes of this contract, “minority” refers to, but is not limited to, Asian-Americans, African-Americans, Latinos, North American Indians, and Cape Verdeans. Town refers to the Town of Arlington.

During the performance of this contract, the Contractor and all of her/his Sub-contractors (hereinafter collectively referred to as the Contractor) for herself/himself, her/his assignees, and successors in interest, agree as follows:

1. In connection with the performance of work under this contract, the Contractor shall not discriminate against any employee or applicant for employment because of race, color, religious creed, national origin, age or sex. The aforesaid provision shall include, but not be limited to, the following: employment upgrading, demotion, or transfer; recruitment advertising; recruitment layoff; termination; rates of pay or other forms of compensation; conditions or privileges of employment; and selection for apprenticeship. The Contractor shall post hereafter in conspicuous places, available for employees and applicants for employment, notices to be provided by the Town setting forth the provisions of the Fair Employment Practices Law of the Commonwealth (M.G.L. Chapter 151B).
2. In connection with the performance of work under this contract, the Contractor shall undertake in good faith affirmative action measures designed to eliminate any discriminatory barriers in the terms and conditions of employment on the grounds of race, color, religious creed, national origin, age or sex, and to eliminate and remedy any effects of such discrimination in the past. Such affirmative action shall entail positive and aggressive measures to ensure equal opportunity in the areas of hiring, upgrading, demotion or transfer, recruitment, layoff or termination, rate of compensation, and in-service or apprenticeship training programs. This affirmative action shall include all action required to guarantee equal employment opportunity for all persons, regardless of race, color, religious creed, national origin, age or sex. A purpose of this provision is to ensure to the fullest extent possible an adequate supply of skilled tradesman for this and future Town public construction projects.
3. As part of her/his obligation of remedial action under the foregoing section, the Contractor shall maintain on this project a not less than five percent ratio of minority employee man hours to total man hours in each job category including but not limited to bricklayers, carpenters, cement masons, electricians, ironworks, operation engineers and those “classes of work” enumerated in Section 44C of Chapter 149 of the Massachusetts General Laws.
4. In the hiring of minority journeyman, apprentices, trainees and advances trainees, the Contractor shall rely on referrals from a multi-employer affirmative action program approved by the Town, traditional referral methods utilized by the construction industry, and referrals from agencies, not more than three in number at any one time, designated by the Liaison Committee or the Town.
5. At the discretion of the Town there may be established for the life of this contract a body to be known as the Liaison Committee. The Liaison Committee shall be composed of one representative each from the agency or agencies administering this project, hereinafter called the administering agency, the Town and such other representative as may be designated by the Town in conjunction with the administering agency.
6. The Contractor (or her/his Agent, if any, designated by him as the on-site equal employment opportunity officer) shall recognize the Liaison Committee as an

affirmative action body, and shall establish a continuing working relationship with the Liaison Committee, consulting with the Liaison Committee on all matters related to minority recruitment, referral, employment and training.

7. The Contractor shall prepare projected manning tables on a quarterly basis. These shall be broken down into projections, by week, or workers required in each trade. Copies shall be furnished one week in advance of the commencement of the period covered, and also when updated, to the Town or Liaison Committee.
8. Records of employment referral orders, prepared by the Contractor, shall be made available to the Town and to the Liaison Committee on request.
9. The Contractor shall prepare weekly reports in a form approved by Town of hours worked in each trade by each employee, identified as minority or non-minority. Copies of these shall be provided at the end of each such week to the Town and to the Liaison Committee.

If the Contractor shall use any sub-contractor on any work performed under this contract, s/he shall take affirmative action to negotiate with qualified minority sub-contractors. This affirmative action shall cover both pre-bid and post-bid periods. It shall include notification to the Office of Minority Business Assistance (within the Executive Office of Communities and Development) or its designee, while bids are in preparation, of all products, work or services for which the Contractor intends to negotiate bids.

In the employment of journeymen, apprentices, trainees and advanced trainees, the Contractor shall give preference, first, to citizens of the Commonwealth who have served in the armed forces of the United States in time of war and have been honorably discharged there from or released from active duty therein, and who are qualified to perform the work to which the employment relates, and, secondly, to citizens of the Commonwealth generally, and, if such cannot be obtained in sufficient numbers, then to citizens of the United States.

A designee of the Town and a designee of the Liaison Committee shall each have right of access to the construction site.

1. Compliance with Requirements

The Contractor shall comply with the provisions of Executive Order O, 74, as amended by Executive Order NO. 116 dated May 1, 1975, and of Chapter 151B as amended, of the Massachusetts General Laws, both of which are herein incorporated by preference and made a part of this contract.

2. Non-Discrimination

The Contractor, in the performance of all work after award, and prior to completion of the contract work, will not discriminate on grounds of race, color, religious creed, national origin, age or sex in employment practices, in the selection or retention of sub-contractors, or in the procurement of materials and rentals of equipment.

3. Solicitations for Sub-Contracts, and for the Procurement of Materials and Equipment

In all solicitations either by competitive bidding or negotiation made by the Contractor either for work to be performed under a sub-contractor for the procurement of materials or equipment, each potential sub-contractor or supplier shall be notified in writing by the Contractor of the Contractor's obligations under this contract relative to non-discrimination and affirmative action.

4. Bidders Certification Requirement

1. The bidder's certification form currently in use will be deleted from all future bid documents.
2. The following certification statement will be inserted in the bid document just above the bidders signature, as a substitute for the present bidder certification form:

“The bidder hereby certifies s/he shall comply with the minority manpower rations and specific action steps contained in the appendix EEO attached hereto, including compliance with the minority contractor compliance specified in Section V of said appendix. The contractor receiving the award of the contract shall be required to obtain from each of its sub-contractors and submit to the contracting or administering agency prior to the performance of any work under said contract a certification by said sub-contractor, regardless of tier, that it will comply with the minority manpower ration and specific affirmative action step contained in the appendix EEO.”

5. Contractor's Certification

The Contractor's certification form must be signed by all successful low bidder(s) prior to award by the contracting agency. (See attachment).

6. Compliance-Information, Reports and Sanctions

1. The Contractor will provide all information and reports required by the administering agency or the Town on instructions issued by either of them and will permit access to its facilities and nay books, records, accounts and other sources of information which may be determined by Town to the affect the employment of personnel. This provision shall apply only to information pertinent to the Town's supplementary affirmative action contract requirements. Where information required is in the exclusive possession of another who fails or refuses to furnish this information, the Contractor shall so certify to the administering agency of the Town as appropriate and shall set forth what efforts s/he has made to obtain the information.
2. Whenever the administering agency, the Town, or the Liaison Committee believes the General Contractor or any Sub-contractor may not be operating in compliance with the terms of this Section, the Town directly, or through it designated agent, shall conduct an appropriate investigation, and may confer with the parties, to determine if such Contractor is operating in compliance with this Section. If the Town or its agent finds the General Contractor or any Sub-contractor not in compliance, it shall make a preliminary report on non-compliance, and notify such Contractor in writing of such steps as will in the judgment of the Town or its agent bring such Contractor into compliance. In the event that such Contractor fails or refuses to fully perform such steps, the Town shall make a final report of non-compliance, and recommend to the administering agency the imposition of one or more of the sanctions listed below. If, however, the Town believes the General Contractor or any Sub-contractor has taken or is taking every possible measure to achieve compliance, it shall not make a final report of non-compliance. Within fourteen (14) days of the receipt of the recommendations of the Town, the administering agency shall move to impose one or more of the following sanctions, as it may deem appropriate to attain full and effective enforcement:
 - a. The recovery by the administering agency from the General Contractor of 1/100 of 1% of the contract award price or \$1000 whichever sum is greater,

in the nature of liquidated damages or, if a Sub-contractor is in non-compliance, the recovery by the administering agency from the General Contractor, to be assessed by the General Contractor as a back charge against the Sub-contractor, of 1/10 of 1% of the sub-contract price, or \$400 whichever sum is greater, in the nature of liquidated damages, for each week that such party fails or refuses to comply.

- b. The suspension of any payment or part thereof due under the contract until such time as the General Contractor or any Sub-contractor is able to demonstrate her/his compliance with the terms of the contract.
 - c. The termination, or cancellation, of the contract, in whole or in part, unless the General Contractor or any Sub-contractor is able to demonstrate within a specified time her/his compliance with the terms of the contract.
 - d. The denial to the General Contractor or any Sub-contractor of the right to participate in any future contracts awarded by the administering agency for a period of up to three years.
3. If at any time after the imposition of one or more of the above sanctions a Contractor is able to demonstrate that s/he is in compliance with this Section, s/he may request the administering agency, in consultation with the Town, to suspend the sanctions conditionally, pending a final determination by the Town as to whether the Contractor is in compliance. Upon final determination of the Town, the administering agency, based on the recommendation of the Town, shall either lift the sanctions or re-impose them.
 4. Sanctions enumerated under Sections 2 shall not be imposed by the administering agency except after an adjudicatory proceeding, as that term is used M.G.L. c. 30A has been conducted. No investigation by the Town or its agent shall be initiated without prior notice to the Contractor.

7. Severability

The provisions of this section are severable, and if any of these provisions shall be held unconstitutional by any court of competent jurisdiction, the decision of such court shall not affect or impair any of the remaining provisions.

VII. SPECIAL CONDITIONS

A. SCOPE OF SPECIAL CONDITIONS

Whenever conditions as set forth in SECTION SC – SPECIAL CONDITIONS conflict with SECTION C – CONTRACT OR SECTION S – DETAIL SPECIFICATIONS, the SPECIAL CONDITIONS shall apply.

B. MINIMUM LIMITS FOR INSURANCE

The minimum limits required under “C.23 – Insurance” in SECTION – CONTRACT shall be as follows:

- a. Compensation Insurance – as required by the General Laws of the Commonwealth of Massachusetts.
- b. Contractor’s Public Liability Insurance – in an amount not less than \$500,000 for injuries including wrongful death to any person and subject to the same limit for each person in an amount not less than \$1,000,000 on account of one accident.
- c. Property damage Insurance – in an amount not less than \$500,000 for a single accident or less than \$1,000,000 in the aggregate.

C. RETAINAGE

The Town shall retain five (5) percent of any periodic estimate and one (1) percent of the value of the completed contract for repairs for a period of one (1) year from substantial completion.

D. PAYMENT OF SUMS DUE CONTRACTOR

Replace SECTION – C-38 of the Contract with the following:

C-38 – Payment of Sums Due Contractor – All payments and retainage shall be in accordance with SECTION 39G of Chapter 30 of the Massachusetts General Laws.

E. DISPOSAL OF EXCAVATED MATERIAL

It shall be the Contractor’s responsibility to dispose of unsuitable material and any excavated material including pipe, gates, hydrants and fittings which are not required for use within the locus of the work, as determined by the Engineer and/or the Director of Public Works, outside the locus of the work, in a Contractor furnished disposal area, and shall become the property of the Contractor.

F. EXCERPTS FROM CERTAIN LAWS

Particular attention is called to certain excerpts of the General Laws of the Commonwealth of Massachusetts.

Preference in Employment of Labor:

In the employment of mechanics, teamsters, chauffeurs and laborers in the construction of this public work, the Contractor shall give preference first, to citizens of the Commonwealth who have been residents of the Commonwealth for at least six months at the commencement of their employment who are veterans as defined in General Law (Ter. Ed.), Chapter 4, Section 7, Clause 43, and who are qualified to perform the work to which the employment relates; and secondly, to citizens of the Commonwealth who have been residents of the Commonwealth for at least six months at the commencement of their employment, and if they cannot be obtained in sufficient numbers, then to citizens of the United States. Veterans and citizens of the Town shall be give preference in employment of the work.

Labor, Lodging, Board, Maximum Hours of Employment and Weekly Payment:

Every employee in public work shall lodge, board and trade where and with whom s/he elects; and no person or her/his agents or employees under contract with the Commonwealth, a county, city or town, or with a department, board, commission or officer acting therefore, for the doing of public work shall directly or indirectly require as a condition of employment therein, that the employee shall lodge, board or trade at a particular place or with a particular person per General Law (Ter. Ed.), Chapter 149, Section 25.

No laborer, workman, mechanic, foreman or inspector working within the Commonwealth, in the employ of the Contractor, sub-contractor or other person doing or contracting to do the whole or a part of the work contemplated by this contract, shall be required to work more than eight (8) hours in any one day or more than forty-eight (48) hours in any one week, or more than six (6) days in any one week, except in cases of emergency, or in case any Town subject to Section 31 of the General Laws is a party to such a contract, more than eight (8) hours in any one day, except as aforesaid. General Laws (Ter. Ed.), Chapter 149, Section 34, as amended.

Attention of the bidders is called to Chapter 149, Section 148 of the General Laws (Ter. Ed.), and amendments thereof requiring the weekly payment of employees.

G. REGULATIONS OF THE COMMONWEALTH OF MASSACHUSETTS

This contract is subject to the requirements of the Massachusetts General Laws (MGL) of which the following are of major significance:

MGL Chapter 30, Section(s) 39F, G, N, O and P.

MGL Chapter 30, Section 40

MGL Chapter 30, Section 39R

MGL Chapter 30, Section(s) 39K and L

MGL Chapter 44, Section 31C (chapter 693 of 1964)

MGL Chapter 82, Section 40 (chapter 353 of 1983)

MGL Chapter 149, Section 34

H. ADJACENT CONTRACTS

The Contractor's attention is directed to the fact that work by utility companies, municipal departments and other contractors may be carried on concurrently within and adjacent to the limits of the contract. The said companies, municipal departments and other contractors may require access over the site and the Contractor shall do her/his work in cooperation with them. The attention of the Contractor is also directed to the provisions of General Laws, Chapter 82, Section 40 which requires Contractor to notify public utility companies, in writing, at least seventy-two (72) hours (excluding Saturdays, Sundays, and legal holidays) before excavating that portion of the project that is within a public way. This notification is the sole responsibility of the Contractor.

I. TRAFFIC ORDERS

The Town of Arlington will pay all charges for the services of uniformed police officers. The contractor will be responsible for coordination of ordering and/or cancelling police details as needed. Cancellations must be made a minimum of 1-hour in advance of the scheduled detail. The Contractor will be liable for charges incurred for cancellations that occur less than 1-hour in advance of the scheduled detail.

J. TIME FOR COMPLETION AND LIQUIDATED DAMAGES

All the work proposed under this contract, shall be completed in accordance with the below-phased milestones:

- **Base Bid and Bid Alternates – Completed by November 15, 2017**

In case the Contractor fails to satisfactorily complete the entire work contemplated and provided for under her/his contract on or before the date of completion as determined herein, the Town shall deduct from the payments due the Contractor the sum of one thousand dollars (\$1000.00) for each calendar day (Saturdays, Sundays and legal holidays excluded) of delay, which sum is agreed upon not as a penalty, but as fixed and liquidated damages for each day of such delay, to be paid in full and subject to no deduction. If the payments due to the Contractor are less than the amount of said liquidated damages, said damages shall be deducted from any other monies due or to become due the Contractor, and in case the damages exceed the amount of all monies due or to become due the Contractor, the Contractor, or her/his Surety, shall pay the balance to the Town. No work shall be done between November 15st and April 15th without the express consent of the Director of Public Works.

K. RESTORATION OF SURFACE

It shall be the responsibility of the Contractor to restore all surfaces in accordance with Section S56. (Bituminous Concrete Paving and Concrete Walks). No more than one-hundred fifty (150) feet of trench shall be left without temporary patch during the work week, and no trenches shall be left without temporary patch during weekends or municipally recognized holidays.

L. PROTECTION OF TREES

The attention of the Contractor is directed to the fact that there may be existing trees located near water service renewal trenches. Extreme caution shall be taken by the Contractor to assure that these trees are not harmed during construction operations.

The Contractor shall notify the Arlington Department of Public Works Tree Division in advance of initiating operations in close proximity to any tree. When tree roots are encountered during trench excavation, the Contractor shall notify the Department of Public Works Tree Division, and uncover the remainder of the roots within the confines of the excavation with hand tools. The exposed roots shall be thoroughly soaked with water and protected with burlap, paper or polyethylene from the direct rays of the sun. Tree roots shall not be cut by the Contractor except with the expressed permission of the Department of Public Works - Tree Division.

M. INTERPRETATION OF CONTRACT

This contract shall be interpreted in accordance with the laws of the Commonwealth of Massachusetts. All actions, claims and disputes hereunder shall be presented to the applicable agency of the Commonwealth of Massachusetts.

N. CONTROL OF WATER SYSTEM

The Arlington Department of Public Works Water and Sewer Division shall maintain control of the use or operation of any and all gate valves, hydrants, etc., and shall be notified by the Contractor forty-eight (48) hours in advance of any use or operation of the above except in a case of an emergency; however, the Department of Public Works Water and Sewer Division shall be informed immediately upon said emergency use or operation.

O. CONTROL OF AND NOTICE TO ABUTTERS OF INTERUPTION OF WATER SERVICE

The Contractor shall give at least forty-eight (48) hour notice to the AFFECTED RESIDENTS of the need to withdraw a water main from service in order to facilitate the disconnection or connection of the new mains with existing mains. This notification shall be prepared by the Town of Arlington Engineering Division and be distributed by the Contractor at the direction of the Engineer.

P. AWARD OF CONTRACT

The Town reserves the right to award the contract in part or in whole.

Q. WORKSITE DUST CONTROL

The worksite shall be kept free of dust and other sediments to the greatest extent practical. In an effort to accomplish this, on a weekly basis the entire site shall be swept by a vehicle-mounted, mechanical sweeper. All sweepings & material collected from this required cleaning shall be properly disposed of at the full cost & responsibility of the Contractor.

Between weekly sweepings, the contractor shall use calcium chloride as needed to control dust on-site. Calcium chloride shall be applied when ordered by the Engineer and only in areas which will not be adversely affected by the application. Calcium chloride shall be uniformly applied at the rate of 1 ½ pounds per square yard or at any other rate as directed by the Engineer. Application shall be by means of a mechanical spreader or other approved methods. The number and frequency of applications shall be determined by the Engineer.

Calcium chloride used on-site shall conform to the requirements of AASHTO-M144, Type I or Type II and Specification for Calcium Chloride, ASTM D98. The calcium chloride shall be packaged in moisture proof bags or in airtight drums with the manufacturer, name of product, net weight and percentage of calcium chloride guaranteed by the manufacturer legibly marked on each container. Calcium chloride failing to meet the requirements of the aforementioned specifications or that which has become caked or sticky in shipment, may be rejected by the Engineer.

R. CONSTRUCTION SEQUENCE

Upon execution of the contract, the construction sequence shall be summated by the Contractor and approved by the Engineer.

VIII. REMOVAL OF UNDERGROUND NON - FRIABLE ASBESTOS CEMENT PIPE

A. GENERAL

A. Definitions:

“**Friable**” – material can be crushed, pulverized, or reduced to powder, when dry, by hand pressure.

“**Non-friable**” – material that cannot be crushed or pulverized under hand pressure.

- B. This section specifies requirements for the removal of non-friable (pipe that has been below the groundwater level or is in otherwise saturated soils will generally be non-friable because it has been saturated/wet) asbestos cement pipe during trenching and excavation operations associated with the installation of new water pipes, where existing AC pipes may be encountered.
- C. All asbestos cement pipe that is shown on the drawings and which is removed during construction is the responsibility of the Contractor, for removal, transportation and proper disposal.

B. SUBMITTALS:

The Contractor shall submit to the Engineer the following listed items at least fourteen (14) days before work is to proceed. No asbestos pipe removal work activities shall commence until the Engineer reviews these items, unless otherwise waived.

Submittal No. 1

Plan of action and Standard Operating Procedure: Submit a detailed plan of the procedures proposed for use in complying with all applicable regulations and the requirements of this specification.

Submittal No. 2

Name, location, and copies of applicable licenses for primary and secondary landfill for disposal of asbestos-containing or asbestos-contaminated waste.

Submittal No. 3

Within thirty (30) days of receipt of asbestos waste at the approved landfill, the Contractor shall submit to the Engineer the original copy of the “Waste Shipment Record” acknowledging disposal of all associated waste material from the Contractor, showing delivery date, quantity, and appropriate signature of Contractor, transporter, and landfill’s authorized representative.

C. GENERAL APPLICABILITY CODED, REGULATIONS AND STANDARDS:

All applicable federal, state and municipal codes, regulations, and standards have the same force and affect (and are made a part of the contract documents by reference) as if copied directly into the contract documents, or as if published copies are bound herewith. All regulations by governing agencies in their most recent version are applicable. Provisions contained in this

specification that are more stringent than applicable codes, regulations and standards shall govern this project.

D. MATERIALS

- A. Wetting materials: For wetting before disturbance of asbestos-containing materials, use either amended water or a removal encapsulant. The material must be odorless, non-flammable, non-toxic, non-irritating, and non-carcinogenic. It shall be applied as a mist using a low-pressure sprayer recommended by the manufacturer.
 - 1. Amended water: Provide water to which a surfactant has been added. Use a mixture of surfactant and water which results in wetting of the asbestos-containing material and retardation of fiber release during disturbance of the material equal to or greater than that provided by the use of one (1) ounce of a surfactant consisting of fifty (50) percent polyoxyethylene ester and fifty (50) percent polyoxyethylene ether mixed with five (5) gallons of water.
 - 2. Removal encapsulant: Provide a penetrating type encapsulant designed specifically for removal of asbestos-containing material. Use a material which results in wetting of the asbestos-containing material and retardation of fiber release during disturbance of the material equal or greater than that provided by water amended with one ounce of a surfactant consisting of fifty (50) percent polyoxyethylene ester and fifty (50) percent polyoxyethylene ether mixed with five (5) gallons of water.
- B. Encapsulant: A material that surrounds or embeds asbestos fibers in an adhesive matrix, to prevent release of fibers.
 - 1. Bridging Encapsulant: An encapsulant that forms a discrete layer on the surface of an in situ asbestos matrix.
 - 2. Penetrating Encapsulant: An encapsulant that is absorbed by the in situ asbestos matrix without leaving a discrete surface layer.
 - 3. Removal Encapsulant: A penetrating encapsulant specifically designed for removal of asbestos-containing materials rather than for in situ encapsulation.
- C. Polyethylene Sheet: Provide flame resistant polyethylene film that conforms to requirements set forth by the National Fire Protection Association Standard 701, Small Scale Fire Test for Flame-resistant Textiles and Films. Provide largest size possible to minimize seams, 6.0 mils thick as required, frosted or black as indicated.
- D. Duct Tape: Provide duct tape in 2" or 3" widths as indicated, with an adhesive which is formulated to aggressively stick to sheet polyethylene, is waterproof, and will adhere to other materials.
- E. Spray Cement: Provide spray adhesive in aerosol cans that is specifically formulated to stick tenaciously to sheet polyethylene.
- F. Waste Containers: Provide 6-mil thick leak-tight polyethylene bags labeled as follows:

DANGER

CONTAINS ASBESTOS FIBERS

AVOID CREATING DUST

CANCER AND LUNG DISEASE HAZARD

If the waste material contains sharp edges or may otherwise puncture polyethylene bags, provide labeled drums or other closed containers for storage, transportation, and disposal.

- G. Warning Signs and Labels: Shall comply with 29 CFR 1926.59(k), and other federal, state, or local codes and regulations.
- H. Brushes: All brushes should have nylon bristles. Wire brushes are excluded from use due to their potential to shred asbestos fibers into small fibers. Wire brushes may be used on pipe joint applications upon prior written notice to the Engineer.

E. CONSTRUCTION METHODS

1. General

- A. Non-friable asbestos cement pipe shall be handled, transported, and disposed of in a way that prevents it from becoming friable and releasing asbestos fibers. Asbestos cement pipe cannot be shattered, crumbled, pulverized, sanded, chipped, or ground.
- B. Non-friable asbestos cement pipe may not be used as fill; it shall be disposed of at a landfill that is State approved to accept asbestos waste. Landfills may require special packaging and labeling in order to accept asbestos cement pipe.
- C. Asbestos cement pipe shall not be removed from the excavation if it is not necessary to disturb it during installation of the new pipeline.
- D. Asbestos cement pipe shall never be handled unless it is wet. Dry pipe shall be wet down with a suitable wetting material prior to handling it.

2. ASBESTOS CEMENT PIPE DURING EXCAVATION:

- A. This section is provided for removal of asbestos cement pipe in excavation areas.
- B. Removal of Non-Friable Asbestos Materials:
 - 1. Carefully excavate, by hand, a sufficient area around the pipe to perform the work. Any asbestos debris that is present or generated by these activities will be promptly wetted and placed into 6-mil asbestos bags before continuing with the work.
 - 2. Once excavation is complete, place one layer of 6-mil polyethylene sheeting on sidewalls and bottom of trench under the asbestos cement pipe to be removed.

3. Thoroughly encapsulate asbestos cement pipe with an acceptable penetrating encapsulant per manufacturer guidelines.
4. Remove asbestos cement pipe as follows: Cut material into manageable sections using HEPA-filtered saw. The Contractor will take all necessary precautions to avoid any breakage of asbestos cement pipe. Cut ends of pipe will be immediately encapsulated. Cut sections of pipe will be removed from the trench and immediately wrapped and sealed in two layers of 6-mil asbestos waste bags. Packaged waste will then be placed into the acceptable waste transportation vehicle. Whenever possible, the Contractor will limit cutting of asbestos cement materials and dismantle materials in intact sections.

3. ASBESTOS CEMENT PIPE LEFT IN PLACE

- A. Ends of asbestos cement pipe to be left in the excavation shall be encapsulated. Asbestos cement pipe is not to be crushed and left in place. Any crushed pieces must be removed and properly disposed of.

4. ASBESTOS CEMENT PIPE DISPOSAL PROCEDURES

- A. The Contractor shall package, label, and remove all asbestos cement pipe as specified below. Packaging shall be accomplished in a manner that minimizes waste volume, but insures waste containers shall not tear or break. Transportation and disposal of the containerized waste at an approved landfill shall be the responsibility of the Contractor.

B. Waste Labeling:

1. Warning labels, having waterproof print and permanent adhesive in compliance with OSHA, EPA and Department of Transportation requirement shall be affixed to or printed on the sides of all waste bags or transfer containers. Warning labels shall be conspicuous and legible.
2. In compliance with NESHAPS, 40 CFR, Part 61.150, all waste containers or bags shall be labeled with the following generator information:
 - a. Name of waste generator.
 - b. Location where waste was generated.

F. MEASUREMENT AND PAYMENT

ITEM 12, 24, 36 Removal, Disposal and Handling of Transite Pipe Linear Foot

Removal, Disposal and Handling of transite pipe will be measured by the linear foot, removed and disposed.

The unit prices above shall include full compensation for all labor, material and equipment necessary for removing, disposing, and handling of transite pipe in accordance with this specification.

IX. EXCAVATION AND BACKFILL

A. GENERAL

- A. The work under this section shall include all excavation to such width and depth as shown on the drawings, specified herein, or ordered by the Engineer. Such excavation may be for the laying of pipes or appurtenances, the removal of pipes or appurtenances, the capping or plugging of pipes to be abandoned, test pits to locate existing utilities, or any other purpose for which excavation may be needed.
- B. Wherever a percentage of compaction for backfill is indicated or specified, it shall be the percent of maximum density at optimum moisture as determined by Method D of ASTM Standard Methods of Test for Moisture - Density Relations of Soils Using 10-lb. rammer and 18-inch Drop, Designation D 1557-78.

B. CLASSIFICATION

Excavation shall be classified as follows:

- a. TRENCH EXCAVATION - shall consist of all earth excavation, within the limits specified herein, required to lay all pipes and appurtenances as shown on the plans or ordered by the Engineer.
 - a) Whenever an excavation is dug to a depth of five feet or more as directed by the Town, the trench shall be supported in accordance with the rules and regulations for the prevention of accidents in construction operations pursuant to Section 129A of Chapter 149 of the General laws and current OSHA regulations.
 - b) The contractor shall furnish, place and maintain such sheathing as may be necessary to support the sides of the excavation and prevent movement of earth which would cause injury, delay the work or endanger adjacent structures.
- B. Normal depth of trench excavation shall be six inches (6") below the bottom of the pipe in earth.
- C. Normal width of trench excavation in sheathed trenches up to 12 feet deep shall be measured between vertical planes which are a distance apart that is equal to the sum of the outside diameter of the pipe plus the total width of the sheathing including walers plus 2 feet. Such trench width shall in no case be less than 4 feet 2 inches or 5 feet if walers are used as part of the sheathing system. The Contractor shall not be entitled to any additional compensation for trench excavation that exceeds the minimum allowable for trench excavation in sheathed trenches, whether the increase in width is due to Contractor means and methods, unstable subsurface materials, or for any other reason.
- D. Normal trench widths for trenches supported with approved trench boxes or hydraulic shoring systems shall be the sum of the outside diameter of the pipe plus 1 foot on either side of the pipe, the width of the wall shield (no greater than 8 inches), plus 1 foot of additional space to allow for installation of the trench box. The Contractor shall not

be entitled to any additional compensation for trench excavation that exceeds the minimum allowable for trench excavation in trench boxes or shoring systems, whether the increase in width is due to Contractor means and methods, unstable subsurface materials, or for any other reason.

- E. Normal width of trench excavation in unsheathed trenches shall be measured between vertical planes, which are a distance that is equal to the sum of the outside diameter of the pipe plus 2 feet. The Contractor shall not be entitled to any additional compensation for trench excavation that exceeds the minimum allowable for trench excavation in unsheathed trenches, whether the increase in width is due to Contractor means and methods, unstable subsurface materials, or for any other reason.
- F. Such trench width shall in no case be less than 3 feet except trenches for building services that shall be a maximum of 2 feet 6 inches wide.
 - a. MISCELLANEOUS TRENCH EXCAVATION shall consist of all excavation beyond the limits of normal trench excavation as ordered in writing by the Engineer, including test pits ordered or approved by the Engineer.
 - b. TRENCH ROCK EXCAVATION shall be any rock greater than 1 1/2 cubic yards in size as shown on the plan or ordered by the Engineer to be excavated. Limits of rock excavation shall be six (6) inches from the outside diameter of the pipe.

C. CONSTRUCTION METHODS

1. GENERAL

- A. Excavation shall be carried out to the lines and grades as set forth above as shown on the plans or as ordered by the Engineer. All excavation beyond such limits is done at the Contractor's expense. Furnishing, placing and compacting suitable backfill material for such over-excavation shall also be at the Contractors' expense.
- B. Prior to excavation of all trenches in paved areas, the Contractor shall cut through the existing pavement and base course in neat straight lines with a minimum amount of vibration. Pavement, except sidewalks or as allowed in writing by the Engineer, shall be cut using a mechanical saw or a machine mounted hydraulic or mechanical tool fitted with a rotary-type blade, and shall result in sound vertical edges, thus avoiding any damage to the pavement or base course outside of the trench limits. Should additional excavation be required in an area that was previously provided temporary paving by the Contractor, the Contractor shall be required to once again saw cut through the pavement in neat straight lines.
- C. Whenever an excavation is dug to a depth of five feet or more as directed by the Town, the trench shall be supported in accordance with the rules and regulations for the prevention of accidents in construction operations pursuant to Section 129A of Chapter 149 of the General laws and current OSHA regulations.

The contractor shall furnish, place and maintain such sheathing as may be necessary to support the sides of the excavation and prevent movement of earth which would cause injury, delay the work or endanger adjacent structures

Sheathing shall be driven ahead of the excavation to avoid loss of material from behind the sheathing, except as may be otherwise permitted by the Town. Care should be taken to prevent voids outside of the sheathing. If voids occur, they shall be filled immediately with sand and compacted, or with controlled density fill.

All sheathing shall be left in place unless otherwise directed by the Town. Where wailers and bracing are to be salvaged by the Contractor, they shall not be removed until the backfill is consolidated up to within 2 feet of the bracing to be removed. The normal cutoff point is two feet below finished grade unless otherwise directed by the Town.

- D. All excavations shall be kept free of all water. The Contractor shall submit the method for dewatering at the pre-construction meeting for approval by the Engineer.
- E. The following materials shall be considered earth excavation for purposes of measurement and payment:
 - 1. Street or sidewalk pavement of all kinds including bituminous concrete, concrete, brick or other materials.
 - 2. Obstructions visible in whole or in part before beginning work such as trees, hedges, stumps, roots and fences.
 - 3. Obstructions indicated on the drawings.
 - 4. Brick or other masonry of old foundations.
 - 5. Catch basins, manholes, pipes and similar existing structures not in use.
 - 6. Dry stone walls with stones less than one and one-half (1-1/2) cubic yards in volume.
 - 7. Sheeting, shoring or bracing of existing structures including piles, pile caps and cradles.
- F. All existing gas pipes, electric conduit, telephone conduit, cable TV conduit, telecommunications conduit, water, sewer or drain lines and any other structures, which are uncovered by the excavation, shall be carefully supported and protected from injury by the Contractor. The Contractor shall restore any items damaged by him to their original condition, and they shall be kept in repair during contract operations. The restoration of existing utility lines shall be done as promptly as practical and shall not be left until the end of the construction.
 - 1. Tie cards/Record Drawings of water, sewer, & drain mains/services within the work limits are include as an appendix in this specification package. The contractor shall be responsible for marking out these utility locations in the field. In the absence of a tie card, the Town will assist in locating the service.

- G. As excavation operations approach known underground structures, the excavation around the structure should be performed by means of hand tools to safely expose the structure as a normal part of trench excavation. A minimum 5' buffer on either side of marked utilities shall be assumed.
- H. Where determination of the exact location or elevation of a pipe or other structure is necessary, the Contractor shall excavate test pits along the proposed alignment as part of normal trench excavation, to determine such locations far enough ahead of the work so that the pipe alignment can be properly determined. Test pits ordered by the Engineer beyond the limits of the trench work shall be paid for under Miscellaneous Trench Excavation.
- I. Excavating equipment shall be operated with care to prevent damage to trees, overhead branches, overhead utilities and other structures. Wherever work will disturb existing trees, the Contractor will notify the Town's Tree Warden. The Town will be responsible for cutting any roots or branches of existing trees. Branches and roots shall not be cut without the written approval of the Engineer. All cutting shall be done neatly by approved methods without splitting or crushing.
- J. Plantings and trees shall be adequately protected or removed and later re-established in their original position and condition. Where injury is such as to diminish their beauty or usefulness, they shall be replaced by items of kind and quality at least equal to that existing at the start of the work.
- K. The Contractor shall not use any equipment whose movement will cut or otherwise injure paved surfaces.
- L. Where material is found below the grade to which excavation is carried which is unsuitable for foundation in the opinion of the Engineer, the Contractor shall remove and dispose of such material to the required width and depth and replaced with thoroughly compacted screened gravel or gravel as directed by the Engineer.
- M. The Contractor shall maintain the area of her/his activities to control dust by sweeping and/or sprinkling of the streets or as otherwise determined to be necessary by the Engineer.
- N. As soon as practicable after the pipes have been laid, except as provided hereinafter, the backfilling shall be started around the pipe to the limits and with the material indicated on the drawings. Unless indicated otherwise on the drawings, all backfill material shall be newly bought gravel or approved processed gravel. This material shall be filled evenly on both sides of the pipe to the indicated grades and rammed with suitable tools so as to be compacted to at least 95 percent.
- O. Backfill shall not be placed on frozen material.
- P. The trench above a level one (1) foot over the top of the pipe shall be backfilled and compacted by mechanical tamping or rolling (maximum weight of roller one (1) ton within three (3) feet of pipe) in accordance with the nature of the material

and as approved by the Engineer. Puddling may only be used when the material does not contain so much clay or loam as to delay or prevent satisfactory drainage.

- Q. Backfilling of the entire trench before the pipeline has successfully passed any specified tests required shall be at the Contractor's option and risk. The Contractor shall be responsible for removing and later replacing such backfill, at her/his own expense, should s/he be ordered to do so in order to locate and repair improperly placed pipe or to repair leakage or defective joints or pipe.
- R. The material shall be deposited in layers of not more than eight (8) inches in depth before compaction. Each layer shall be tampered or rolled as required to obtain a thoroughly compacted mass. Care shall be taken that the material shall first be wet by sprinkling as directed or approved. However, no compaction shall be done when the material is too wet.

2. TRENCH EXCAVATION

- A. Trench excavation shall be carried out as specified herein and shown on the plans.
- B. Trenches may be excavated to their full depth by machinery provided that the material remaining at the bottom of the trench is no more than slightly disturbed.
- C. The Contractor should anticipate that due to existing utility lines, hand excavation will be required.
- D. Trench excavation shall result in a flat or shaped trench bottom, true to grade so that the pipe will have uniform and continuous bearing on a firm support. Trenches shall be made as narrow as practicable, and every effort shall be made to keep the sides of the trenches firm and undisturbed until backfilling and compaction are completed.

3. MISCELLANEOUS TRENCH EXCAVATION

- A. This excavation shall be carried out in a similar manner to trench excavation, but to limits beyond the established limits for normal trench excavation as determined by the Engineer.

4. TRENCH ROCK EXCAVATION

- A. Only such rock, as in the opinion of the Engineer, that requires a hoe ram for its removal, and boulders over one and one-half (1-1/2) cubic yards in volume, will be measured and paid for as rock excavation.
- B. Rock shall also include monolithic concrete or reinforced concrete or stone structures greater than 1 1/2 cubic yards as a solid mass.
- C. Rock in pipe trenches shall be excavated so as to be not less than 6 inches from the outside wall of the pipe. Before the pipe is laid, the trench below the pipe, where rock excavation has been made, shall be backfilled and compacted with suitable material, as that required for bedding the pipe.

- D. The Contractor shall observe all State, Federal and municipal laws, ordinances and regulations relating to the transportation, storage, handling and use of explosives. In the event that the regulations require a licensed blaster to perform or supervise the work, said licensed blaster shall have her/his license at the site and shall permit examination thereof by the Engineer. All required City, State and Federal permits and other required documentation shall be provided to the Engineer prior to undertaking any blasting.
- E. The Contractor shall submit to the Engineer an accurate record of each blast showing the time, location, depth, number of drill holes, the kind and quantity of explosives used and other data required for a complete record.
- F. All excavated rock shall be removed and disposed of unless otherwise directed by the Engineer.

5. UNSUITABLE BACKFILL MATERIAL

- A. Excavated soil that has been evaluated as unsuitable for reuse as backfill shall be removed from the site and disposed of properly. New material, which meets the requirements presented hereinto, shall be brought in to replace excavated soil found to be unsuitable.
 - 1. The soil excavated from a trench shall be evaluated by experienced personnel to determine whether or not it is suitable as a backfill in accordance with this section. An excavated soil that has been evaluated as suitable for backfill shall be reused provided its moisture content has been determined to be “suitable” in accordance with standards for proper moisture content.
 - 2. Suitable backfill material shall be free of stones larger than half the size of the compacted lift as provided for in Mass DOT Standard Specifications for Highway Bridges, construction debris, trash, frozen soil and other foreign material. Suitable materials consist (but are not limited to) the following:
 - a. Well graded gravel and sand;
 - b. Poorly graded gravel and sand;
 - c. Gravel-sand mixtures with a small amount of silt;
 - d. Gravel-sand mixtures with a small amount of silt and trace amounts of clay.

Unsuitable backfill materials consist (but are not limited to) of the following:

- a. Inorganic silts and clays;
- b. Organic silts;
- c. Organic soils including peat, humus, topsoil, swamp soils, mulch, and soils containing leaves, grass, branches, and other fibrous vegetable matter.

D. MEASUREMENT AND PAYMENT

ITEM 9, 21, 33 Trench Rock Excavation Cubic Yard

ITEM 10, 22, 34 Miscellaneous Trench Excavation Cubic Yard

ITEM 11, 23, 35 Unsuitable Trench Material Cubic Yard

No separate measurement and payment will be made for Trench Excavation. All costs in connection therein shall be considered incidental to furnishing and laying of water pipe as provided under these specifications and shall include all work described in this section, including trench support as required.

Trench Rock Excavation shall be measured by the cubic yard. This item shall include all rock excavation necessary to lay the pipe at the grade specified. Such excavation shall extend to a point at least six (6) inches around the outside diameter of the pipe. The amount paid under this item shall include all mechanical means to excavate rock, blasting, and any other work necessary to remove the rock.

Trench Rock Excavation will be paid for at the Contract unit price per cubic yard, which price shall be full compensation for all costs for excavating, hauling and disposal of clean, unsuitable or surplus excavated material. Excavation Material that is suitable for reuse as directed by the Engineer will be re handled, placed, compacted and graded at no additional cost.

For purposes of payment boulders at least one and one-half cubic yards in volume shall be considered as Rock Excavation. Boulders less than one and one-half cubic yards shall be considered normal earth excavation.

Miscellaneous Trench Excavation shall be measured by the cubic yard. This item shall include only such excavation as may be ordered by the Engineer. Since the main purpose of this item, although not its only purpose, is for test-pits, the Contractor should anticipate that hand excavation will be involved. Excavation and repair of packing leaks shall be included under this item.

Miscellaneous Trench Excavation will be paid for at the Contract unit price per cubic yard, which price shall be full compensation for all costs for excavating, hauling and disposal of clean, unsuitable or surplus excavated material. Excavation Material that is suitable for reuse as directed by the Engineer will be re handled, placed, compacted and graded at no additional cost.

Unsuitable Material shall be measured by the cubic yard. This item shall include excavation necessary to remove the material as well as supplying, placing and compacting suitable material in its place as directed in these specifications.

Unsuitable Material will be paid for at the Contract unit price per cubic yard, which price shall be full compensation for all costs for excavating, hauling and disposal of the excavated material. The price shall include supplying, placing and compacting suitable material as detailed in Section S5.

X. GRAVEL

A. GENERAL

Gravel shall be used as backfill material in all trench excavations, rock excavations, miscellaneous trench excavations and any other location where specified herein, as called for in the appropriate pipe specifications, as shown on the plans or order by the Engineer.

Weight slips may be requested by the Engineer to verify the source of the Gravel. Such slips shall bear the name of the supplier, date purchased and the weight of the gravel. Such slips shall not be used as a method of measuring the gravel for payment.

B. MATERIAL

Gravel shall consist of inert material that is hard, durable stone and coarse sand free from loam and clay surface coatings, be well graded and contain no stone having any dimension greater than three (3) inches.

Gravel shall conform to the following requirements:

Passing 3 inch sieve.....	100%
Passing 1 1/2 inch sieve.....	70-100%
Passing 3/4 inch sieve.....	50 - 85%
Passing No. 4 sieve.....	30 - 60%
Passing No. 200 sieve.....	0 - 10%

New bank run or processed gravel is acceptable but must meet the above requirements and be processed by mechanical means. All processed gravel shall come from an approved stockpile. The equipment producing the processed gravel shall be of adequate size and with sufficient adjustments to produce the desired materials. The processed material shall be stockpiled in such a manner to minimize segregation of particle sizes.

C. CONSTRUCTION METHODS

Gravel refill shall be placed, spread and compacted as set forth in the Excavation and Backfill section of these specifications. Gravel shall not be placed on frozen ground.

Before pipe is placed, a gravel base shall be installed. The gravel base shall be a minimum of 6” deep or as directed by the Town.

D. MEASUREMENT AND PAYMENT

No separate measurement and payment will be made for work required under this Section. All costs in connection therein shall be considered incidental to the item(s) of work to which they pertain.

XI. DUCTILE IRON PIPE AND FITTINGS

A. GENERAL

This section covers the removal and replacement of existing water pipe including services larger than 2-inches in diameter, the abandonment in place of existing water pipe, and the laying of new water pipe, including, but limited to, excavation, excavation support, gravel, backfill, and surface restoration.

B. MATERIALS

A. Ductile Iron Pipe

Unless otherwise shown on the plans or specified herein all water pipe shall be ductile iron cement lined designed in accordance with ANS21.50/AWWA C150-96 and manufactured in accordance with ANS A21.51/AWWA C151-96.

Unless otherwise indicated or specified, ductile iron pipe shall be special thickness Class 52 for diameters sixteen (16) inches or less.

Pipes shall be double cement-mortar lined in accordance with ANS A21.4/AWWA C104-95.

All pipe shall be push-on joint conforming to ANS A21.11/AWWA C111 latest version. Pipe shall be delivered in eighteen (18) foot lengths.

Push-on joints shall be provided with sufficient quantities of accessories conforming to ANS A21.11/AWWA C111.

B. Fittings

The Contractor shall furnish and install all the required fittings shown on the plans or as directed by the Engineer. All fittings shall be ASTM A-536 ductile iron, cement lined mechanical joint. All fittings 3-inch through 48-inch in diameter shall meet or exceed the requirements of AWWA C-110. Compact fittings shall be ductile iron meeting or exceeding the requirements of AWWA C-153.

All fittings 4" to 24" shall be pressure rated at 350 PSI working pressure. Fittings shall conform to the weights, excluding accessories, and dimensions shown in the latest edition of the Handbook of Ductile Iron Pipe and come complete with all joint accessories as required. All accessories (gland, gaskets, T-bolts and nuts) shall be in accordance with AWWA C-111. All mechanical joint bolts (T-bolts) shall be Cor-Ten or equal.

C. Couplings

When connecting ductile iron pipe to cast iron pipe the contractor shall use sleeve couplings. When connecting ductile iron pipe to ductile iron pipe the contractor shall use solid sleeve mechanical joint fittings manufactured in accordance with these specifications.

Sleeve couplings and accessories shall be pressure rated for a minimum of 150 PSI. Couplings shall be ductile iron or steel. The couplings shall be provided with "Cor-Ten" bolts and nuts or approved equal.

After assembly, all surfaces of the bolts and nuts shall be thoroughly coated with two coats of an asphaltic coating. The interior and exterior of the coupling shall be epoxy-coated.

C. **CONSTRUCTION METHODS**

A. GENERAL

1. Care shall be taken in loading, transporting, and unloading to prevent injury to the pipes or coatings. Pipe or fittings shall not be dropped.
2. Pipes and fittings shall be subjected to a careful inspection by the Town before installation. All defective pipe and fittings shall be removed from the site at no cost to the Town. If any portion of the pipe is cracked or defective the entire length shall be removed.
3. All pipe and fittings shall be thoroughly cleaned before laying and shall be kept clean until used in the work. Each pipe shall be cleared of all excess tar, debris, dirt, etc., before laying.
4. Push-on joints shall be made up by first inserting the gasket into the groove of the bell and applying a thin film of non-toxic gasket lubricant uniformly over the inner surface. The chamfered end of the plain pipe shall be inserted into the gasket and forced past it until it seats against the bottom of the socket.
5. When cutting pipe is required, the cutting shall be done by machine leaving a smooth cut at right angles to the axis of the pipe. Cut ends of pipe shall be beveled to conform to the manufactured spigot end. Cement lining shall be undamaged.
6. Whenever encountered within the trench, existing water mains shall be removed. All existing water mains outside of the trench limits which are left in place and abandoned, shall be capped at all ends.
7. Ductile iron pipe and fittings shall be installed in accordance with the requirements of AWWA Standard Specification C600, except as otherwise approved by the Town. A firm, even bearing throughout the length of the pipe

shall be constructed by tamping selected material at the sides of the pipe up to the springline. **Blocking will not be permitted.**

8. Water pipe shall be laid with a minimum cover of five and one-half (5 1/2) feet or to the grade of the existing pipe unless otherwise shown on the plan or directed by the Town.
9. When laying is not in progress, including lunchtime; the open ends of the pipe shall be closed by watertight plug or other approved means. The Contractor shall keep the trench free from water while the pipe is being installed.
10. Fittings, in addition to those shown on the plans, shall be provided, if required, in crossing utilities, which may be encountered.
11. At the direction of the Town, all existing valves and hydrants removed from service shall be delivered to the Town's storage yard. Any valves and hydrants that the Town does not want delivered to the Town storage yard, shall become the responsibility of the contractor for disposal. All pipe that is removed shall be the property of the Contractor, and it shall be the Contractor's responsibility for disposal.

B. THRUST RESTRAINT

1. Fittings, plugs and hydrants shall be restrained against hydraulic thrust through the use of "Megalug" or approved equal mechanical restraint in lieu of thrust blocks.

C. DEFLECTION

1. In laying a full 18 foot length of ductile iron pipe along a curve, the maximum changes in alignment of each length of pipe using push on joints shall not exceed 19 inches for pipes 4"-36". The amount of allowable deflection for pipe greater than 36" shall be in accordance with the manufacturers' specifications.

D. PRESSURE TESTS

1. The pipelines shall be tested (in sections if required by the Engineer) for strength and for leakage at a pressure of 150 pounds per square inch. The tests for leakage shall last for at least one hour and may be required to last two hours. The additional water needed to maintain the required pressure shall be accurately measured in a manner approved by the Engineer. The container shall be clearly labeled with its capacity in gallons.
2. Tests shall be made for all newly installed pipe and when required by the Engineer. A 24-hour notice shall be given to the Engineer prior to all tests. The Contractor shall furnish all apparatus; material and labor necessary for making the tests, including caps temporarily set to accommodate pressure testing.

3. The Contractor will make all necessary arrangements for securing the water for test purposes and will stand the expense of these arrangements. The water required for testing will be furnished by the Town without charge to the Contractor from the Town's existing water system. The Contractor shall provide the Town with an estimate of Town water used during all tests.
4. During this test all hydrant laterals shall be in the open position. Methods of testing and plans showing sections to be tested are to be submitted to the Engineer for approval as requested. The Contractor shall not perform a pressure test against existing valves unless authorized by the Engineer. Generally s/he shall set a cap at the limit of work for main line water work.
5. The rate of leakage shall not exceed the following for pipe of 18 foot nominal laying length:

Pipe Diameter (inches)	Allowable Leakage per 1000' of Pipe
4	0.37 Gallons
6	0.55 Gallons
8	0.74 Gallons
12	1.10 Gallons

6. The Contractor shall repair all leaks discovered under any of the required tests.

E. CHLORINATION AND DE-CHLORINATION OF THE PIPELINE

1. Upon completion of the pipe line and all the testing thereof, the interior of the pipe shall be flushed and then thoroughly disinfected in all parts. This disinfection must result in eliminating from the various parts of the new pipe line all evidence of the existence therein of bacteria indicative of any contamination, as determined by tests of the bacterial content of samples of water taken from the new water main. The disinfection may be accomplished by introducing into all the various parts of the new water mains a liquid solution containing one percent available chlorine in such volume that the rate of dosage to the water mains shall be at least 50 parts per million of available chlorine. The contact period for this disinfection shall be at least twenty-four hours, and a longer period will be required if tests of residual chlorine show it to be less than the required minimum of 25 mg./l. The water system shall be flushed out after its disinfection. The Contractor shall furnish and install suitable temporary testing plugs, caps, pumps, pipe connections, blow offs, and other appurtenances as necessary and all labor required for testing bacteria and disinfecting the water mains.
2. Water used for chlorination shall be de-chlorinated prior to disposal. The Town shall approve of the location of the discharge of the de-chlorinated water.

3. All work shall be done in accordance with AWWA C-651. Connections at cuttings shall be swabbed with a 50-PPM solution of chlorine at locations when other methods are not applicable.
4. The Contractor shall provide a copy of the results of the pressure and chlorination tests to the Town prior to activation of the water main. Results of the chlorination tests shall be documented by a laboratory certified by the Massachusetts Department of Environmental Protection. The Contractor shall also provide the Town with an estimate of water used during all testing.
5. The Pressure Testing and Disinfection Reports shall be completed by the Contractor and approved by the Town prior to any payments being made for pipe.

D. MEASUREMENT AND PAYMENT

ITEM 2a, 14a, 26a Furnish & Install 12” Cement Lined Ductile Iron Pipe & Fittings Linear Foot

ITEM 2b, 14b, 26b Furnish & Install 8” Cement Lined Ductile Iron Pipe & Fittings Linear Foot

ITEM 2c, 14c, 26c Furnish & Install 6” Cement Lined Ductile Iron Pipe & Fittings Linear Foot

ITEM 2d, 14d, 26d Furnish & Install 4” Cement Lined Ductile Iron Pipe & Fittings Linear Foot

The length of ductile iron water pipe to be paid for under the appropriate size designated shall be measured linear foot along the finished grade over the pipe from end to end as laid. No deduction for the length of valves or fittings in the pipe shall be made.

Proposed pipe location shown on plans in schematic. Any necessary deviations from the locations shown due to unforeseen field conditions (utility crossing conflicts, etc.) will not be measured or paid for separately.

Six (6) inch CLDI installed as part of a hydrant installation shall not be included under Items 2c, 14c, or 26c, but under the associated items for hydrant installations (4, 5, 16, 17, 28, and 29).

The unit price paid for Furnishing & Installing Ductile Iron Water Pipe shall be full compensation for cutting and disposal of pavement, trench excavation, sheeting and bracing as required, dewatering, placing and compacting gravel and backfill materials, removal and disposal of existing water mains (if ordered by the engineer), removal and delivery to Town facility (or disposal if ordered by the Engineer) of all valves and appurtenances, furnishing and laying of new water pipe and fittings as shown on the plans or ordered by the Engineer, all items and labor related to the approved installation of thrust restraint, surface restoration,

temporary paving to last a period of one winter, and all else in connection with the laying of water main for which there is no separate pay item.

E. NEW CEMENT LINED DUCTILE IRON PIPE

In addition to the requirements already set forth, the following shall apply:

The new cement lined ductile iron pipe shall include the furnishing and installing of all crosses, tees, bends, couplings and other miscellaneous fittings, including appropriately sized crosses or tees, pipe and couplings necessary to connect the new mains with existing mains.

If an existing water main is exposed within the trench limits, shown to be removed on the bid plans and/or at the discretion of the Town, it shall be the responsibility of the Contractor to remove and dispose of the existing main including all fittings and valves that are exposed.

Existing water mains that are to be abandoned in place and/or at the discretion of the Town shall be abandoned in accordance with the following:

1. Water mains must be abandoned in place by using mechanical devices manufactured specifically for such purposes to completely seal the ends of the pipe.
2. Mechanical joint plugs or mechanical joint caps with watertight gaskets must be installed at the termination points of the abandoned water main.
3. Oversized mechanical joint caps or plugs may be required depending on the outside diameter for the existing water pipe.
4. Remove valve boxes on valves on abandoned mains to a minimum of one (1) foot below top of grade in unpaved areas, or to bottom of sub-grade in paved areas. Remainder of valve box is to be filled and capped.

F. PIPE FITTINGS

All pipe fittings shall be ductile iron with mechanical joints. An ample supply of fittings shall be kept on the job site at all time. All fittings shall be American made.

XII. GATE VALVES AND BOXES

A. GENERAL

The Contractor shall furnish and install all gate valves and boxes where indicated on the drawings and in accordance with all specifications contained herein.

B. MATERIALS

1. GENERAL

- A. All gate valves shall be “Resilient Wedge” type as manufactured by Mueller, Traverse City, or Kennedy, or approved equal and shall open in a clockwise direction (turn to right).
- B. All valves shall be American Flow Control Series 2500, open to the right (or approved equal).
- C. All insertion valves shall be EZ Valve Permanent Valve Insertion System (or approved equal).
- D. All operating nuts shall be two (2) inches square at the base, tapering to 1-15/16 inches square at the top.
- E. All valves shall open to the right (clockwise).
- F. The interior of all valve bodies and other ferrous metal parts, which will come in contact with water, shall be epoxy coated.
- G. All bonnet bolts, seal plate bolts, stuffing box bolts, and other bolts in contact with soil (except for MJ bolts) shall be 18-8 Type 304 stainless steel or Everdur bronze.

2. VALVE BOXES

- A. All valves four (4) inches and larger shall be provided with a box and cover.
 - a. Valve boxes shall be cast iron, two – piece, sliding type with a top flange and a minimum inside shaft diameter of 5-1/4”.
 - b. All roadway covers shall be cast clearly with the word “water”.
 - c. The valve-operating nut shall be centered in the valve tube and visible upon installation.
 - d. Valve box manufacturer shall be ISO – 9002 certified.

3. CONSTRUCTION METHODS

- A. All material shall be inspected for defects prior to installation. Defective materials shall be immediately removed from the site.
- B. All foreign matter shall be removed from valve openings and seat faces.
- C. All nuts and bolts shall be checked for tightness.

D. Blocking shall be placed under each valve to insure against settlement.

4. MEASUREMENT AND PAYMENT

Item 3a, 15a, 27a Furnish & Install 12” Gate Valve and Gate Valve Box Each

Item 3b, 15b, 27b Furnish & Install 8” Gate Valve and Gate Valve Box Each

Item 3c, 15c, 27c Furnish & Install 6” Gate Valve and Gate Valve Box Each

Item 3d, 15d, 27d Furnish & Install 4” Gate Valve and Gate Valve Box Each

The quantity of valves to be paid for shall be the actual count, in place and complete, installed by the Contractor in accordance with the plans and these specifications.

The unit price paid under the above items shall be full compensation for earth excavation; removal of existing valve; removal of existing masonry valve chamber if found; returning of removed valve to the Town’s storage yard; furnishing and setting valve; furnishing and setting access tube, frame and cover; and/or roadway box as required; and furnishing and setting pipe nipples needed to set the valve, including couplings.

Six (6) inch gate valves installed as part of a hydrant installation shall not be included under Items 3c, 15c, or 27c, but under the associated items for hydrant installations (4, 16, and 28.

No separate payment shall be made for valve installations required to be completed prior to the installation of temporary by-pass water lines or services.

No separate payment will be made for the removal of any existing valves within the limits of the work.

XIII. POST HYDRANTS

A. GENERAL

- A. This section covers the installation of new hydrants and the resetting of existing hydrants.
- B. Prior to putting any existing hydrant out of service for any reason, the Contractor shall notify the Fire Department or the DPW Dispatch in writing.
- C. Hydrants which will be out of service for more than twenty-four (24) hours shall be replaced by temporary hydrants.

B. MATERIALS

- A. Hydrants required to perform the work under this section shall be Waterous Traffic Flow Model, WB67-250, open to the right (or approved equal).

C. CONSTRUCTION METHODS

- A. Hydrants shall be set plumb with the steamer nozzle facing the roadway.
- B. Hydrants shall be set with the center of the operating nut 18 inches back from the face of the curb.
- C. Hydrants shall be set so that manufacturers "bury" mark or ground line is at finish grade. If there is no bury mark on the hydrant, the bottom of the breakaway feature shall be a minimum of 2 inches and a maximum of 4 inches above finished grade.
- D. The depth of bury shall be either 5-1/2 or 6 feet.
- E. Hydrants shall be set on either a flat stone or concrete base at least 14 inches square and 4 inches thick.
- F. Hydrants shall be restrained by using mechanical joint follower glands, rods and clamps, thrust blocks or any combination thereof as required by the Engineer.
- G. A drainage pit shall be excavated below and around each hydrant and backfilled to a height of at least six (6) inches above all drain ports with at least 12 cubic feet of 1 inch to 2 inch crushed stone. This shall be covered with 4-mil thick plastic sheeting.

D. MEASUREMENT AND PAYMENT

ITEM 4, 16, 28 Furnish and Install 6" Hydrant Gate Valve and Gate Valve Box EACH

ITEM 5a, 17a, 29a Remove Ex. Hydrant, Furnish & Install New Hydrant and 6" Hydrant Branch EACH

ITEM 5b, 17b, 29b Remove and Reset Existing Hydrant Including New 6" Hydrant Branch EACH

Furnishing and installing 6" hydrant gate valve and gate valve box shall be measured each complete and in place. Payment will be made at the contract unit price per each and will include all labor, material and equipment necessary to complete the work.

Removing and disposing of existing hydrants and furnishing and installing new hydrants including 6" branch will be measured per Each complete and in place.

The unit price shall include full compensation for all labor, material and equipment necessary for removing and disposing of the existing pavement; excavating and backfilling of trench; resetting curb; replacing damaged sidewalks; installing and maintaining both temporary and permanent trench patching; removing and disposing of existing 6" branches, gate valve and hydrants; furnishing and installing new hydrants including thrust blocks and 6" branches as shown on the plans or as directed and all other incidental work.

E. HYDRANT REPLACEMENT AND NEW HYDRANT

Where existing hydrants are to be removed and replaced with new hydrants, the existing hydrant, hydrant branch and gate valve shall be removed and disposed of by the Contractor at the direction of the Town. The replacement hydrant as well as hydrants at new locations shall be furnished and installed, including new 6" branches, thrust blocks and surface restoration. All hydrants shall be manufactured by Waterous.

Attention is also directed to any hydrants that are not traffic models. This will be determined in the field, or by the Department of Public Works.

F. HYDRANT REMOVE AND RESET

Existing hydrants, hydrant branches and gate valves so designated, shall be removed and the hydrant branches and gate valves disposed of by the Contractor. The existing hydrants shall be reset with new 6" hydrant branches and gate valves furnished by the Contractor.

XIV. TEMPORARY BY-PASS SYSTEM

A. GENERAL

- A. The Contractor shall furnish, install, chlorinate, maintain and remove bypass and temporary service pipe of the size required to adequately service water customers.
- B. The Contractor shall provide temporary services for the customers whose permanent service line is:
 - 1. Out of service due to the main pipe to which it is connected to being replaced.
 - 2. Out of service due to the main pipe to which it is connected to being cleaned and cement lined.
 - 3. Out of service due to the main pipe to which it is connected being served only by the main being rehabilitated or replaced, including dead end pipes and pipes ending at division gates.
 - 4. Out of service for any other reason in connection with work under this contract
- C. The Contractor shall locate all services to be fed by the by-pass system, including both domestic and fire service lines. Customer's service lines, which will be out of service for a limited period of time, in the opinion of the Engineer, need not be by-passed but all other provisions regarding adequate notice and hours of shut down shall be strictly adhered to.
- D. A bypass plan shall be submitted to demonstrate compliance with these provisions.
- E. The Contractor shall review with the Town water distribution plans to determine the extent of the by-pass, especially where dead ends and division gates may require by-pass piping. No additional payment shall be considered for the extension of the by-pass to feed services fed from dead ended pipe or pipe where flow is interrupted by a division gate. This may or may not be noted on the plan. In either case the Contractor is responsible for determining the locations of all dead ends.
- F. All by-pass shall be fed from two (2) sources unless otherwise approved by the Town.
- G. In the event a bypass pipe is dead-ended, it shall terminate with a 2-inch valve for flushing and chlorination.
- H. No by-pass pipe shall be activated prior to approval by the Town. The Contractor will be responsible for written notification to the Arlington Fire Department that the by-pass has been installed and, to provide a copy to the of such notification to the Town.

B. MATERIALS

- A. All by-pass shall be galvanized steel, H.D.P.E. or polyvinylchloride (PVC) pipe. All plastic pipe or hose shall bear the imprint of the National Sanitary Foundation approval

for potable water NSF-PW or shall be capable of meeting the standards established by the NSF for this use.

- B. The materials selected shall be adequate to operate at the pressure to which they will be subject to and adequate to withstand whatever forces, such as traffic loading, they will encounter. Joints for all pipe shall be watertight.
- C. The Town reserves the right to reject at any time materials that do not meet the requirements set forth herein.

C. CONSTRUCTION METHODS

- A. In general, by-pass piping shall be laid along the side of the roadway adjacent to the curb line edge of pavement line.
- B. At locations where the pipe is subject to minimal traffic, such as at driveways, the pipe shall be adequately protected by excavating and setting the pipe below grade or "ramping" it with bituminous concrete or other suitable material.
- C. All by-pass pipes that cross handicapped ramps, intersections, or extends around the radius of an intersecting street shall be installed below the surface grade unless otherwise approved by the Town.
- D. Where necessary to feed large services, the Contractor may be required to excavate the sidewalk or other areas adjacent to a building to cut into the existing service or fire pipe. The cost of this work will be included in the bid price for Temporary By-pass Pipe including backfill and paving.
- E. The Contractor will be required, where necessary, to ramp over all by-pass piping to provide for wheelchair access on affected sidewalks. Ramping shall be in accordance with ADA (Americans with Disabilities Act) regulations.
- F. At locations where the pipe is subject to regular traffic, such as where it crosses traveled lanes; the pipe MUST be set below grade and the trench adequately filled to withstand the traffic loads. At such areas all work must be done in accordance with the applicable sections contained herein relating to trench excavation and paving. These requirements shall include, but are not limited to, cutting the pavement neatly to avoid excess damage to existing pavement.
- G. The interior of all by-pass pipe, temporary service pipe and service hoses shall be flushed to remove any dirt or other objects and shall be disinfected in accordance the Ductile Iron Pipe and Fittings specification section: Chlorination and De-chlorination of Pipeline.
- H. At all locations where hydrants are out of service due to work under this contract, the contractor shall provide temporary hydrants. A hydrant being used to feed temporary hydrants must be fed by 6-inch by-pass pipe including whip connections and must be fitted with a butterfly valve with pentagonal operating nut, which can be turned with a hand wrench. The valve shall be painted blue for easier identification. The valve shall be equipped with a 1/4-turn stop, which will not allow the operating nut to go beyond the closed position. All temporary hydrants shall have one 4 1/2-inch outlet, located with the

centerline of the outlet parallel with the curb line, the face of the nozzle perpendicular to the road surface, and between 1 1/2 and 2 1/2 feet above the road surface. A threaded cap with a standard pentagonal nut is to be installed at the end of each 4 1/2" hydrant connection.

- I. Adequate precautions shall be taken to protect all vehicular and pedestrian traffic from injury due to by-pass piping and temporary service lines. These precautions shall include, but are not limited to "ramping", barricades and other devices.
- J. All by-pass pipe and service hoses shall be bubble tight at all times. No leakage shall be acceptable.
- K. No by-pass pipe shall remain in place after November fifteenth, and none shall be put in service prior to April fifteenth unless otherwise approved by the Town.

D. MEASUREMENT AND PAYMENT

ITEM 1, 13, 25 Furnish & Install and Remove Temporary Bypass Mains and Services Lump Sum

Temporary bypass lines will be measured and paid for by the Lump Sum which price and payment shall be full compensation for all excavation and backfilling including tap-holes and restoration of existing surface (cement concrete or bituminous concrete) to its original condition prior to excavation; for furnishing, installing, maintaining and removing temporary fire hydrants and temporary house connections; for all tapping and other approved valved connections into fire or other service pipes; for furnishing, installing, decontaminating and sterilizing, maintaining and removing the temporary bypass pipe, hydrants and house connections, including connecting and disconnecting the bypass pipe to an existing water supply, all temporary valves, fittings, and other facilities necessary to provide temporary fire and domestic service including connections and disconnections; for all special provisions that may be required at driveways, street crossings, or otherwise for the protection of the temporary pipe, and for all the labor, materials, equipment and other incidental work.

E. TEMPORARY BYPASS WATER LINES AND SERVICES

The Contractor shall be responsible for furnishing temporary facilities for supplying water service and fire protection as required until the work is completed. The Contractor's method and design for providing temporary service and fire protection shall be approved by the Engineer and/or the Director of Public Works prior to commencing work.

Upon execution of the contract, a plan for lying of all bypass lines and services shall be submitted to the Engineer and the Director of Public Works for approval. No bypass lines shall be laid prior to this approval. The Engineer and/or the Director of Public Works shall make the final decision as to the routing of all bypass lines.

The plan may include a request to interrupt water service for a period of time up to eight (8) hours, without the use of temporary services.

Areas requiring temporary services may vary depending on the construction sequence submitted by the Contractor and approved by the Engineer/Director of Public Works.

Special attention must be given to areas, that while not apparent, may require temporary services.

XV. SERVICE LINES

A. GENERAL

The work under this section shall be the replacement of existing service lines two (2) inches or smaller in diameter and installation of new service lines both in public and private property. Services larger than 2-inch diameter are installed under the applicable CLDI pipe items.

B. SERVICE RENEWAL

Existing water services shall be replaced from the main to the back edge of the sidewalk (ROW line) by the Contractor, including corporation cocks, copper service pipe and curb stops (Open Right).

All service lines fed from the water main being replaced must be reconnected to the new water main unless otherwise directed by the Engineer. The Town specifies that all services 2-inches and smaller be copper.

Existing service pipe material may be lead, galvanized iron, cast or ductile iron, plastic or copper.

C. MATERIALS

Materials for all service lines 2-inches or less shall be in accordance with the following:

1. Copper Tubing shall be soft, annealed, seamless tubing conforming to Federal Specifications WW-T799A, Type "K".
 - a) To minimize joints, coiled tubing shall be used.
 - b) Joints in copper tubing shall be made with three part compression couplings, flared tube fittings (ASA spec. B-16), or an approved equal. All fittings shall be electrically conductive.
2. Corporation Stops:
 - a) Shall be cast bronze ball valves, conforming to the latest ASTM specification for Steam or Valve Bronze Castings, Serial Designation B62.
 - b) Shall be equal in size to the stop being replaced, with 3/4 inch being the minimum size.
 - c) For 2-inch service lines, shall be 1 1/2-inch stops fitted with a 2-inch outlet adaptor or shall be 1 1/2-inch stops with 2-inch outlets.
 - d) Shall be a ball valve with a full round smooth waterway, which operates freely. It shall meet all the requirements of AWWA C800. The valve shall be equipped with a removable tee head, which can be attached to the operating head of the valve after tapping. The tee head shall be a minimum of 1-inch in height. The valve shall open to the right.

- e) Shall be tested under a hydrostatic pressure of 250 pounds per square inch and found to be tight before leaving the factory.
- f) Shall have Standard Threads on the inlet and all other threads shall be American Standard Wrought Iron Pipe Threads.

3. Roadway service boxes,

- a) Where required, shall have a minimum inside diameter of 4 1/4 inches, shall be coated with asphalt and shall be approved by the Town prior to installation.

4. Curb Stops:

- a) Shall be cast iron bronze, conforming to the specification above for corporation stops.
- b) Shall be equal in size to the new copper pipe, which the stop is connected to.
- c) Shall have full, round, smoothed, reamed waterway and shall operate freely as adjusted for testing.
- d) Shall be a ball valve conforming to AWWA 800 with a one-piece tee head and shall open to the right.
- e) Shall be rated at 250 psi or greater.

5. Sidewalk Boxes:

- a) Shall be Buffalo type with 3" diameter shafts.
- b) Shall be heavy weight, light gray cast iron, true to pattern, and free from flaws.
- c) Shall have length of the two sections at least 70 inches.
- d) Shall have a total weight of approximately 40 pounds.
- e) Shall have a tread plug, which may be removed to operate the stop.
- f) Shall be thoroughly coated with two coats of asphaltum varnish.
- g) Shall be level with sidewalk.

D. CONSTRUCTION METHODS

1. GENERAL

- A. In locations where the existing service line is determined to be adequate by the Engineer, it shall be reconnected to the new water main using a new corporation stop, shoe, tube, and cap. This observation shall be made by the Engineer. If copper pipe is found at the main, the Contractor shall excavate in the sidewalk area to determine if the pipe is still copper. If not then the entire service shall be re-laid with the approval of the Town.

- B. All new copper service lines shall be connected to the existing service line at the property line. In the event that an area sidewalk foundation wall or other subterranean structure exists at the property line, the connection shall be made as close as possible to it and at a maximum 18 inches away from the same.
- C. All service connections shall be tested for strength and tightness before being backfilled; they shall be tested under the normal pressure in the water mains to which they are connected, and any signs of leakage or evidence of failure shall be promptly repaired by the Contractor at her/his own expense. The Contractor shall furnish all apparatus, material, and labor for making the tests. The water required for testing shall be furnished by the Town, without charge to the Contractor, from the Town's existing water system.
- D. The Contractor shall also be responsible for removing any sediment deposit that may accumulate and impede the full flow of water when restoring the water services.
- E. Service lines shall be chlorinated in accordance with the applicable parts of the Ductile Iron Pipe and Fittings specification section.

2. SERVICE LINES

- A. Shall be a minimum of 3/4 inch in diameter.
- B. Shall have a minimum depth of cover of 5.5 feet, or as approved by the Town.

3. CORPORATION STOPS

- A. Shall be threaded into a tap in the main at the horizontal diameter of the main.
- B. Shall have the tap made in the main by means of a tapping machine manufactured for this purpose and supplied by the Contractor. The tap and drill shall be kept sharp and shall have standard threads unless otherwise approved by the Town.
- C. Shall be screwed firmly into the water main with the key upward and the inlet end projecting at least 1/8 inch beyond the inside face of the main.
- D. Shall be left in the on (open) position.
- E. 3/4-inch and 1-inch shall be fitted with a service shoe, tube and cap.
- F. 1½-inch and 1½-inch by 2-inch shall be fitted with a roadway service box.

4. CURB STOPS

- A. Shall be installed on ¾-inch and 1-inch service lines.
- B. Shall be deleted on service lines when the main is in the sidewalk area, and all corporation stops, including ¾-inch and 1-inch, shall be fitted with sidewalk control boxes.
- C. Shall be set in a bed of clean gravel or approved material of equal draining qualities.

E. MEASUREMENT AND PAYMENT

Item 6a, 18a, 30a Furnish and Set ¾" Corporation Cock Each

Item 6b, 18b, 30b Furnish and Set 1" Corporation Cock Each

Item 6c, 18c, 30c Furnish and Set 2" Corporation Cock Each

Item 7a, 19a, 31a Furnish and Install ¾" Copper Service Pipe and Fittings
Linear Foot

Item 7b, 19b, 31b Furnish and Install 1" Copper Service Pipe and Fittings
Linear Foot

Item 7c, 19c, 31c Furnish and Install 2" Copper Service Pipe and Fittings
Linear Foot

Item 8a, 20a, 32a Furnish and Set ¾" Curb Stop and Box
EA

Item 8b, 20b, 32b Furnish and Set 1" Curb Stop and Box
Each

Item 8c, 20c, 32c Furnish and Set 2" Curb Stop and Box
Each

Furnishing and installing copper service pipe shall be measured by the linear foot along the center line of the pipe from the corporation cock key to the point of intersection with the existing service pipe. No deduction will be made for curb stops or couplings.

The unit price shall include full compensation for all labor, material (including couplings) and equipment necessary for removing and disposing of the pavement; removing and disposing of the existing service pipe and curb stop; excavating and backfilling the trench; furnishing, laying and connecting the copper tubing; resetting curbstone, repairing catch basins and drains if disturbed; replacing damaged sidewalks; installing and maintaining both temporary and permanent trench patching; and all other service

connection work except that for which a definite payment item is stated. No separate or additional compensation will be allowed for sand backfill around the service pipe or for tunneling if used. No driving shall be allowed.

Furnishing and installing corporation cocks, curb stops and boxes shall be measured by each unit complete and in place.

The unit price shall include full compensation for all labor, material and equipment necessary for furnishing and installing the corporation cock, curb stop and curb stop box; and all other incidental work.

XVI. BITUMINOUS CONCRETE PAVING AND CONCRETE WALKS

A. GENERAL

This section covers the restoration of roadways, sidewalks, and landscaped areas in whole or in part.

THE CONTRACTOR SHALL NOT LEAVE EXCAVATED AREAS UNPAVED OVER WEEKENDS AND/OR HOLIDAYS UNLESS THROUGH WRITTEN APPROVAL OF THE ENGINEER.

Except as otherwise specified herein, all work performed under this section shall conform to the Standard Specifications of the Massachusetts Highway Department, latest edition.

Cold patch may be used when hot mix is not available. This is only for the Contractor's convenience and is not considered temporary paving. Where the Contractor has used cold patch s/he will repave the area with acceptable temporary paving as soon as it is available. The Contractor will be required to maintain cold patched areas according to the specifications for temporary paving. There will not be payment for setting of cold patch.

All surface treatments shall be restored with like materials unless otherwise directed by the engineer.

B. CLASSIFICATION

A. Temporary Trench Repair

1. Temporary trench repair shall be required on a weekly basis before the end of the work week.
2. Temporary patches shall preferably be hot Class I Type 1-1 bituminous concrete but may be substituted for with cold mix if hot mix is unavailable and the substitution is authorized by the Engineer.
3. Prior to placement of the Temporary Trench Repair, any broken or irregular edges of existing pavements shall be cut away in straight lines as directed leaving sound vertical faces. Should an area that has been received a temporary trench repair need to be excavated again, the temporary patch shall be cut away in straight lines as was done for the initial pavement cut.
4. The patch shall be laid and compacted in two (2) courses to a minimum of four inches total of compacted thickness to a finished grade matching the existing road surface.
5. The contractor shall maintain temporary patches during the course of the project and for a period of one year from substantial completion of the work, unless otherwise directed by the Engineer. Within 24 hours of notification by the Town, the Contractor shall fill with similar material any depressions and holes that may occur so as to maintain the surface in a safe and satisfactory condition.

6. Following completion of work, temporary patches shall be installed so as to provide safe vehicular and pedestrian travel. The temporary patch shall be placed so as to last for a period of one year from substantial completion of the project. The Contractor will be responsible for maintaining the patch during this period, including shimming of pavement and adjustments needed to ensure safe pedestrian and vehicular travel. The maintenance period of one year may be reduced at the discretion of the Engineer. Permanent trench repair shall not be necessary as the Town will repave the roadway following construction under a separate contract. The Contractor shall be responsible for maintaining the temporary patching in a safe and travelable condition through the spring of the following construction season.
7. Where applicable, all conditions of the constructions methods listed in this section shall apply to temporary repair.

B. Permanent Trench Repair

1. Permanent Trench Repair will not be required under this Contract.

C. MATERIALS

A. Bituminous Concrete

Bituminous concrete pavement placed in all streets shall conform to Commonwealth of Massachusetts's standards and specifications for M3.11.00 Class I, Bituminous Concrete.

B. Tack Coat

Tack coat shall consist of emulsified asphalt, Grade RS-1, conforming to Section M.3.03.0 of the Commonwealth of Massachusetts Department of Public Works Standard Specifications for Highways and Bridges, latest edition.

C. Concrete Cement

Concrete cement placed in all walk and driveways shall conform to Commonwealth of Massachusetts's standards and specifications for M4.02.00, Concrete Cement.

D. CONSTRUCTION METHODS

1. GENERAL

1. All pavement thickness referred to in these specifications are compacted thickness. The Contractor shall place sufficient bituminous concrete mix to insure the specified thickness of pavement occurs after compaction.
2. All frames, grates, covers, street boxes, manhole rings and other castings within the limits of the area to be paved shall be reset, if required, immediately prior to paving.

3. Prior to patching an area, the trimmed edges of existing pavement shall be stable and unyielding, free of loose or broken pieces, and all edges shall be thoroughly cleaned and coated with an asphalt tack coat.
4. All contact surfaces of curbing, existing pavement, castings and other structures shall be coated with an asphalt tack coat.
5. When the air temperature falls below fifty (50) degrees F, extra precautions shall be taken in drying the aggregates, controlling the temperatures of the materials and placing and compacting the mixtures.
6. No mixtures shall be placed when the air temperature is below forty (40) degrees F, nor when the material on which the mixtures are to be placed contains frost or has a surface temperature not suitable to the Inspector.
7. Each layer of bituminous concrete paving material shall be thoroughly compacted with a roller weighing a minimum of two hundred and eighty-five (285) pounds per inch of width.
8. Along curbing, structures, and all places not accessible to the roller, the mixture shall be thoroughly compacted by tampers. Such tampers shall not weigh less than twenty-five (25) pounds and shall have a tamping face of not more than fifty (50) square inches.
9. No vehicular traffic loads shall be permitted on the newly paved area until adequate stability has been attained and the material has cooled sufficiently to prevent distortion or loss of fines.
10. Any disturbed area, Public or Private, shall be restored with Loam and Seed to the Engineer's satisfaction. If substantial completion is completed in the Fall, loam and seed should be provided the following spring.
11. Any disturbed walk or driveway, Public or Private, shall be restored to the Engineer's satisfaction.

2. MAINTENANCE PERIOD OF ROADWAY SURFACE

The Contractor shall be responsible to maintain trenches and patching at her/his expense for a period of one year after the backfilling and patching of the trench and shall promptly refill and repair areas, which have settled or are otherwise unsatisfactory for pedestrian and vehicular traffic.

The Contractor shall be responsible and indemnify and hold the Town harmless for any damages sustained to persons or property as a result of any accident that may occur on account of the defective condition of the street or sidewalk surface.

Final payment or acceptance by the Town of the completed contract shall have no effect on the Contractor's obligation as indicated in the above paragraphs.

3. MEASUREMENT AND PAYMENT

No separate measurement and payment will be made for work required under this Section. All costs in connection therein shall be considered incidental to the item(s) of work to which they pertain. Further, the Contractor shall be liable for all costs associated with additional patching required due to trenches that are larger than the recommended size.

BY-LAWS OF THE TOWN OF ARLINGTON
TITLE I
ARTICLE 16

CONSTRUCTION PROJECTS

Section 1. Women Work Force Participation

Any Town board or official in charge of a construction or reconstruction project is required to include in the contract documents the following:

- A. Contractor shall maintain as a goal on this project a not less than five percent ratio of women work force to total project hours in both the general contract and each individual filed sub-bid contract, if applicable. The preceding sentence shall be included in all construction contracts whether entered into by the Town pursuant to the provisions of M.G.L. c. 149 or M.G. L. c 30, §39M et. seq. provided however, that if entered into under Chapter 30 same shall not be deemed to apply where the projected bid price as determined by the Director of Public Works is not likely to exceed \$200,000.
- B. A Labor Scheduling Table which will be used as a tool for achieving a range of women work force participation for the entire project in both the general contract and each individual filed sub-bid contract.

Section 2. Equal Opportunity Goal Compliance

Any Town board or official in charge of a construction or reconstruction project is required to include in the contract documents the following:

- A. Before starting work, the contractors (includes the general contractor, for itself and its subcontractors, as well as all filed sub-bid contractors, if applicable) will submit plans for achievement of the equal opportunity goals of the contract. All contractors will be required to make a good faith effort to achieve these goals. The plan will indicate if the contractors expect to achieve the requirements during the first quarter. If there are reasons why the contractors do not expect to achieve the requirements during the first quarter year of the contract construction phase, then the contractors shall provide a plan calculated to address, to the extent reasonably possibly, these obstacles to a good faith effort to achieve such goals.
- B. Not more than ten days following the end of each work quarter, the contractors will report on the achievement of the goals, detailing the good faith efforts that have been made and will continue to be made and any other appropriate efforts not yet undertaken.
- C. All reports will be signed by an officer or principal of the company who has the authority to contractually obligate the company.

Section 3. Recruitment and Training

Any board, officer, committee, or other agency of the Town, which acts on behalf of the Town in making or supervising any contract, in an amount exceeding the sum of \$100,000 for the purchase of goods or services or for the construction, renovation, or repair of buildings or other improvement of real estate, may make arrangements with contractors and other interested agencies for special programs of recruitment and training in connection with the work to be performed on such contract, with the objective of promoting equal employment opportunity for members of minority groups protected by the fair employment laws of the Commonwealth and the United States. Any board, officer, committee or other Town agency may expend Town funds in carrying them out provided that appropriations specifically designed for such purposes have been voted by the Town Meeting.



TOWN OF ARLINGTON EQUAL OPPORTUNITY ADVISORY COMMITTEE

730 MASSACHUSETTS AVENUE, ARLINGTON, MA 02476
PHONE (781) 316-3120 FAX: (781) 316-3129

TRICIA O'DONOGHUE, CHAIR
BARBARA BOLTZ
AUGUSTA HAYDOCK
JACK JONES

CARYN COVE MALLOY
EQUAL OPPORTUNITY OFFICER

CONTRACTOR CERTIFICATION

During the performance of the Contract, the Contractor and all subcontractors (hereafter collectively referred to as "the Contractor") for a town construction contract or town assisted construction contract, for him/herself, his/her assignees and successors in interest, agree to comply with all applicable equal employment opportunity, non-discrimination and affirmative action requirements, including but not limited to the following:

The Contractor shall comply with the provisions of Town of Arlington Bylaws, Anti-Discrimination policies and Chapter 151B of the Massachusetts General Laws, as amended, and all other applicable anti-discrimination and equal opportunity laws, all of which are herein incorporated by reference and made a part of this contract.

In connection with the performance of work under this contract, the Contractor shall undertake, in good faith, affirmative action measures to eliminate any discriminatory barrier in the terms and conditions of employment on the grounds of race, color, religious creed, national origin, sex, gender identity, sexual orientation, age, genetic information, ancestry, children, marital status, veteran status or membership in the armed service, the receiving of public assistance, and handicap. Such affirmative action measures shall entail a list of positive and aggressive measures which shall include but not be limited to, advertising employment opportunities in minority and other community news media; notifying minority women and other community-based organizations of employment opportunities; maintaining a file of names and addresses of each worker referred to the Contractor and what action was taken concerning such worker; and notifying this Committee in writing when a union with whom the Contractor has a collective bargaining agreement has failed to refer a minority or woman worker.

The Contractor shall submit to the Equal Opportunity Advisory Committee, through the Purchasing Director Domenic Lanzillotti, the following Contractor's Certification with all attachments. The Contractor's Certification will be reviewed by the Committee and will inform the Contractor of any deficiencies to be corrected.

CONTRACTOR CERTIFICATION

_____ certifies that they:

(Contractor Name)

1. Will not discriminate in their employment practices.
2. Intend to use, if General Contractor, the following listed construction trades in the work under the contract:

3. If Trade Subcontractor, will provide the following work under the contract:

4. Will make good faith efforts to comply with the minority employee and women employee workforce participation ratio goals of the Town of Arlington and the Commonwealth of Massachusetts and specific affirmative steps contained herein; and to provide evidence of its good faith efforts. Attached hereto, please find:

- A. Employment Opportunities advertised in:

- B. Notification to Minority/Women/Community based Organizations such as:

C. List of workers referred to Contractor and note on what action was taken:

D. Written notification that Union/Local No. _____ failed to refer a Minority or
Female worker during the week of: _____

Signature of Officer

Date

Printed Name of Officer and Title

To view and print Weekly Payroll & Statement of Compliance Forms, click on www.mass.gov/dols/pw.

PLEASE NOTE: The attached Prevailing Wage Schedule is valid for 90 days. An Awarding Authority should re-request an up to date Prevailing Wage Schedule if it has NOT opened bids or selected a contractor within 90 days of the issuance date of the attached prevailing wage schedule.

*For MULTI-YEAR projects bid on or after 8/8/08, Awarding Authorities must request an Annual Update to this Prevailing Wage Schedule each year for the duration of the project, no later than two weeks before the anniversary date of the execution of the general contract. Annual updates are not required for projects that last LESS THAN ONE YEAR.

*For CM AT RISK projects (bid pursuant to GL c.149A), Awarding Authorities must request a Prevailing Wage Schedule NOT sooner than 90-days before the earlier of: (a) the execution date of the GMP Amendment, or (b) the bid for the first construction scope of work.

*For MULTI-YEAR CM AT RISK projects, Awarding Authorities must request an Annual Update to this Prevailing Wage Schedule each year for the duration of the project, no later than two weeks before the anniversary date, which is the earlier of: (a) the execution date of the GMP Amendment, or (b) the execution date of the first amendment to procure construction scopes of work.

Apprentice wages (expressed as dollar figures) and the required benefits are listed on the Prevailing Wage Schedule. For further details, please see opinion letter PW-2010-03-03.16.10 (dated March 18, 2010) at www.mass.gov/dols/pw.

Request Prevailing Wage Rates online at: www.mass.gov/dols/pw.

THIS IS A SYSTEM-GENERATED EMAIL. PLEASE DO NOT REPLY TO THIS EMAIL. TO CONTACT DLS REGARDING PREVAILING WAGE MATTERS, CALL 617-626-6953.

=====

APPROVAL/DENIAL COMMENTS

This e-mail message, including any attachments, is for the sole use of the intended recipient(s) and may contain confidential and privileged information. Any unauthorized review, use, disclosure, or distribution is strictly prohibited and may be the subject of legal action. If you are not the intended recipient, please contact the sender by reply e-mail and destroy all copies of the original message. Thank you.



**THE COMMONWEALTH OF MASSACHUSETTS
EXECUTIVE OFFICE OF LABOR AND WORKFORCE DEVELOPMENT
DEPARTMENT OF LABOR STANDARDS**

Prevailing Wage Rates

**As determined by the Director under the provisions of the
Massachusetts General Laws, Chapter 149, Sections 26 to 27H**

RONALD L. WALKER, II
Secretary

WILLIAM D MCKINNEY
Director

CHARLES D. BAKER
Governor

KARYN E. POLITO
Lt. Governor

Awarding Authority: Town of Arlington
Contract Number: 17-32 **City/Town:** ARLINGTON
Description of Work: Provide all labor, equipment, materials and supervision necessary for Water Distribution System Improvements in various locations as required.
Job Location: Various

Information about Prevailing Wage Schedules for Awarding Authorities and Contractors

- This wage schedule applies only to the specific project referenced at the top of this page and uniquely identified by the “Wage Request Number” on all pages of this schedule.
- An Awarding Authority must request an updated wage schedule from the Department of Labor Standards (“DLS”) if it has not opened bids or selected a contractor within 90 days of the date of issuance of the wage schedule. For CM AT RISK projects (bid pursuant to G.L. c.149A), the earlier of: (a) the execution date of the GMP Amendment, or (b) the bid for the first construction scope of work must be within 90-days of the wage schedule issuance date.
- The wage schedule shall be incorporated in any advertisement or call for bids for the project as required by M.G.L. c. 149, § 27. The wage schedule shall be made a part of the contract awarded for the project. The wage schedule must be posted in a conspicuous place at the work site for the life of the project in accordance with M.G.L. c. 149 § 27. The wages listed on the wage schedule must be paid to employees performing construction work on the project whether they are employed by the prime contractor, a filed sub-bidder, or any sub-contractor.
- All apprentices working on the project are required to be registered with the Massachusetts Department of Labor Standards, Division of Apprentice Standards (DLS/DAS). Apprentice must keep his/her apprentice identification card on his/her person during all work hours on the project. An apprentice registered with DAS may be paid the lower apprentice wage rate at the applicable step as provided on the prevailing wage schedule. **Any apprentice not registered with DLS/DAS regardless of whether or not they are registered with any other federal, state, local, or private agency must be paid the journeyworker's rate for the trade.**
- The wage rates will remain in effect for the duration of the project, except in the case of multi-year public construction projects. For construction projects lasting longer than one year, awarding authorities must request an updated wage schedule. Awarding authorities are required to request these updates no later than two weeks before the anniversary of the date the contract was executed by the awarding authority and the general contractor. For multi-year CM AT RISK projects, awarding authority must request an annual update no later than two weeks before the anniversary date, determined as the earlier of: (a) the execution date of the GMP Amendment, or (b) the execution date of the first amendment to permit procurement of construction services. Contractors are required to obtain the wage schedules from awarding authorities, and to pay no less than these rates to covered workers. The annual update requirement is not applicable to 27F “rental of equipment” contracts.
- Every contractor or subcontractor which performs construction work on the project is required to submit weekly payroll reports and a Statement of Compliance directly to the awarding authority by mail or email and keep them on file for three years. Each weekly payroll report must contain: the employee’s name, address, occupational classification, hours worked, and wages paid. Do not submit weekly payroll reports to DLS. A sample of a payroll reporting form may be obtained at <http://www.mass.gov/dols/pw>.
- Contractors with questions about the wage rates or classifications included on the wage schedule have an affirmative obligation to inquire with DLS at (617) 626-6953.
- Employees not receiving the prevailing wage rate set forth on the wage schedule may report the violation to the Fair Labor Division of the office of the Attorney General at (617) 727-3465.
- Failure of a contractor or subcontractor to pay the prevailing wage rates listed on the wage schedule to all employees who perform construction work on the project is a violation of the law and subjects the contractor or subcontractor to civil and

Classification	Effective Date	Base Wage	Health	Pension	Supplemental Unemployment	Total Rate
Construction						
(2 AXLE) DRIVER - EQUIPMENT <i>TEAMSTERS JOINT COUNCIL NO. 10 ZONE A</i>	12/01/2016	\$33.25	\$10.91	\$10.89	\$0.00	\$55.05
(3 AXLE) DRIVER - EQUIPMENT <i>TEAMSTERS JOINT COUNCIL NO. 10 ZONE A</i>	12/01/2016	\$33.32	\$10.91	\$10.89	\$0.00	\$55.12
(4 & 5 AXLE) DRIVER - EQUIPMENT <i>TEAMSTERS JOINT COUNCIL NO. 10 ZONE A</i>	12/01/2016	\$33.44	\$10.91	\$10.89	\$0.00	\$55.24
ADS/SUBMERSIBLE PILOT <i>PILE DRIVER LOCAL 56 (ZONE 1)</i>	08/01/2015	\$88.29	\$9.80	\$19.23	\$0.00	\$117.32
For apprentice rates see "Apprentice- PILE DRIVER"						
AIR TRACK OPERATOR <i>LABORERS - ZONE 1</i>	12/01/2016	\$37.10	\$7.60	\$14.15	\$0.00	\$58.85
	06/01/2017	\$38.10	\$7.60	\$14.15	\$0.00	\$59.85
	12/01/2017	\$38.95	\$7.60	\$14.15	\$0.00	\$60.70
	06/01/2018	\$39.90	\$7.60	\$14.15	\$0.00	\$61.65
	12/01/2018	\$40.85	\$7.60	\$14.15	\$0.00	\$62.60
	06/01/2019	\$41.85	\$7.60	\$14.15	\$0.00	\$63.60
	12/01/2019	\$42.85	\$7.60	\$14.15	\$0.00	\$64.60
For apprentice rates see "Apprentice- LABORER"						
ASBESTOS REMOVER - PIPE / MECH. EQUIPT. <i>HEAT & FROST INSULATORS LOCAL 6 (BOSTON)</i>	12/01/2016	\$33.90	\$11.50	\$7.10	\$0.00	\$52.50
	06/01/2017	\$34.90	\$11.50	\$7.10	\$0.00	\$53.50
	12/01/2017	\$35.90	\$11.50	\$7.10	\$0.00	\$54.50
	06/01/2018	\$36.90	\$11.50	\$7.10	\$0.00	\$55.50
	12/01/2018	\$37.90	\$11.50	\$7.10	\$0.00	\$56.50
	06/01/2019	\$38.90	\$11.50	\$7.10	\$0.00	\$57.50
	12/01/2019	\$39.90	\$11.50	\$7.10	\$0.00	\$58.50
	06/01/2020	\$40.90	\$11.50	\$7.10	\$0.00	\$59.50
	12/01/2020	\$41.90	\$11.50	\$7.10	\$0.00	\$60.50
ASPHALT RAKER <i>LABORERS - ZONE 1</i>	12/01/2016	\$36.60	\$7.60	\$14.15	\$0.00	\$58.35
	06/01/2017	\$37.60	\$7.60	\$14.15	\$0.00	\$59.35
	12/01/2017	\$38.45	\$7.60	\$14.15	\$0.00	\$60.20
	06/01/2018	\$39.40	\$7.60	\$14.15	\$0.00	\$61.15
	12/01/2018	\$40.35	\$7.60	\$14.15	\$0.00	\$62.10
	06/01/2019	\$41.35	\$7.60	\$14.15	\$0.00	\$63.10
	12/01/2019	\$42.35	\$7.60	\$14.15	\$0.00	\$64.10
For apprentice rates see "Apprentice- LABORER"						
ASPHALT/CONCRETE/CRUSHER PLANT-ON SITE <i>OPERATING ENGINEERS LOCAL 4</i>	12/01/2016	\$45.38	\$10.00	\$15.25	\$0.00	\$70.63
	06/01/2017	\$46.38	\$10.00	\$15.25	\$0.00	\$71.63
	12/01/2017	\$47.38	\$10.00	\$15.25	\$0.00	\$72.63
For apprentice rates see "Apprentice- OPERATING ENGINEERS"						
BACKHOE/FRONT-END LOADER <i>OPERATING ENGINEERS LOCAL 4</i>	12/01/2016	\$45.38	\$10.00	\$15.25	\$0.00	\$70.63
	06/01/2017	\$46.38	\$10.00	\$15.25	\$0.00	\$71.63
	12/01/2017	\$47.38	\$10.00	\$15.25	\$0.00	\$72.63
For apprentice rates see "Apprentice- OPERATING ENGINEERS"						

Classification	Effective Date	Base Wage	Health	Pension	Supplemental Unemployment	Total Rate
BARCO-TYPE JUMPING TAMPER <i>LABORERS - ZONE 1</i>	12/01/2016	\$36.60	\$7.60	\$14.15	\$0.00	\$58.35
	06/01/2017	\$37.60	\$7.60	\$14.15	\$0.00	\$59.35
	12/01/2017	\$38.45	\$7.60	\$14.15	\$0.00	\$60.20
	06/01/2018	\$39.40	\$7.60	\$14.15	\$0.00	\$61.15
	12/01/2018	\$40.35	\$7.60	\$14.15	\$0.00	\$62.10
	06/01/2019	\$41.35	\$7.60	\$14.15	\$0.00	\$63.10
	12/01/2019	\$42.35	\$7.60	\$14.15	\$0.00	\$64.10
For apprentice rates see "Apprentice- LABORER"						
BLOCK PAVER, RAMMER / CURB SETTER <i>LABORERS - ZONE 1</i>	12/01/2016	\$37.10	\$7.60	\$14.15	\$0.00	\$58.85
	06/01/2017	\$38.10	\$7.60	\$14.15	\$0.00	\$59.85
	12/01/2017	\$38.95	\$7.60	\$14.15	\$0.00	\$60.70
	06/01/2018	\$39.90	\$7.60	\$14.15	\$0.00	\$61.65
	12/01/2018	\$40.85	\$7.60	\$14.15	\$0.00	\$62.60
	06/01/2019	\$41.85	\$7.60	\$14.15	\$0.00	\$63.60
	12/01/2019	\$42.85	\$7.60	\$14.15	\$0.00	\$64.60
For apprentice rates see "Apprentice- LABORER"						
BOILER MAKER <i>BOILERMAKERS LOCAL 29</i>	01/01/2017	\$42.92	\$6.97	\$16.21	\$0.00	\$66.10

Apprentice - BOILERMAKER - Local 29

Effective Date - 01/01/2017

Step	percent	Apprentice Base Wage	Health	Pension	Supplemental Unemployment	Total Rate
1	65	\$27.90	\$6.97	\$10.54	\$0.00	\$45.41
2	65	\$27.90	\$6.97	\$10.54	\$0.00	\$45.41
3	70	\$30.04	\$6.97	\$11.35	\$0.00	\$48.36
4	75	\$32.19	\$6.97	\$12.16	\$0.00	\$51.32
5	80	\$34.34	\$6.97	\$12.97	\$0.00	\$54.28
6	85	\$36.48	\$6.97	\$13.78	\$0.00	\$57.23
7	90	\$38.63	\$6.97	\$14.59	\$0.00	\$60.19
8	95	\$40.77	\$6.97	\$15.40	\$0.00	\$63.14

Notes:

Apprentice to Journeyworker Ratio:1:5

BRICK/STONE/ARTIFICIAL MASONRY (INCL. MASONRY WATERPROOFING) <i>BRICKLAYERS LOCAL 3 (BOSTON)</i>	03/01/2017	\$50.76	\$10.75	\$19.22	\$0.00	\$80.73
---	------------	---------	---------	---------	--------	---------

Apprentice - BRICK/PLASTER/CEMENT MASON - Local 3 Boston

Effective Date - 03/01/2017

Step	percent	Apprentice Base Wage	Health	Pension	Supplemental Unemployment	Total Rate
1	50	\$25.38	\$10.75	\$19.22	\$0.00	\$55.35
2	60	\$30.46	\$10.75	\$19.22	\$0.00	\$60.43
3	70	\$35.53	\$10.75	\$19.22	\$0.00	\$65.50
4	80	\$40.61	\$10.75	\$19.22	\$0.00	\$70.58
5	90	\$45.68	\$10.75	\$19.22	\$0.00	\$75.65

Notes:

Apprentice to Journeyworker Ratio:1:5

BULLDOZER/GRADER/SCRAPER <i>OPERATING ENGINEERS LOCAL 4</i>	12/01/2016	\$44.94	\$10.00	\$15.25	\$0.00	\$70.19
	06/01/2017	\$45.93	\$10.00	\$15.25	\$0.00	\$71.18
	12/01/2017	\$46.92	\$10.00	\$15.25	\$0.00	\$72.17

For apprentice rates see "Apprentice- OPERATING ENGINEERS"

CAISSON & UNDERPINNING BOTTOM MAN <i>LABORERS - FOUNDATION AND MARINE</i>	12/01/2016	\$37.45	\$7.60	\$14.35	\$0.00	\$59.40
--	------------	---------	--------	---------	--------	---------

For apprentice rates see "Apprentice- LABORER"

CAISSON & UNDERPINNING LABORER <i>LABORERS - FOUNDATION AND MARINE</i>	12/01/2016	\$36.30	\$7.60	\$14.35	\$0.00	\$58.25
---	------------	---------	--------	---------	--------	---------

For apprentice rates see "Apprentice- LABORER"

CAISSON & UNDERPINNING TOP MAN <i>LABORERS - FOUNDATION AND MARINE</i>	12/01/2016	\$36.30	\$7.60	\$14.35	\$0.00	\$58.25
---	------------	---------	--------	---------	--------	---------

For apprentice rates see "Apprentice- LABORER"

CARBIDE CORE DRILL OPERATOR <i>LABORERS - ZONE 1</i>	12/01/2016	\$36.60	\$7.60	\$14.15	\$0.00	\$58.35
	06/01/2017	\$37.60	\$7.60	\$14.15	\$0.00	\$59.35
	12/01/2017	\$38.45	\$7.60	\$14.15	\$0.00	\$60.20
	06/01/2018	\$39.40	\$7.60	\$14.15	\$0.00	\$61.15
	12/01/2018	\$40.35	\$7.60	\$14.15	\$0.00	\$62.10
	06/01/2019	\$41.35	\$7.60	\$14.15	\$0.00	\$63.10
	12/01/2019	\$42.35	\$7.60	\$14.15	\$0.00	\$64.10

For apprentice rates see "Apprentice- LABORER"

CARPENTER <i>CARPENTERS -ZONE 2 (Eastern Massachusetts)</i>	03/01/2017	\$38.77	\$9.90	\$17.00	\$0.00	\$65.67
	09/01/2017	\$39.78	\$9.90	\$17.00	\$0.00	\$66.68
	03/01/2018	\$40.78	\$9.90	\$17.00	\$0.00	\$67.68
	09/01/2018	\$41.82	\$9.90	\$17.00	\$0.00	\$68.72
	03/01/2019	\$42.85	\$9.90	\$17.00	\$0.00	\$69.75

Apprentice - CARPENTER - Zone 2 Eastern MA

Effective Date - 03/01/2017

Step	percent	Apprentice Base Wage	Health	Pension	Supplemental Unemployment	Total Rate
1	50	\$19.39	\$9.90	\$1.63	\$0.00	\$30.92
2	60	\$23.26	\$9.90	\$1.63	\$0.00	\$34.79
3	70	\$27.14	\$9.90	\$12.11	\$0.00	\$49.15
4	75	\$29.08	\$9.90	\$12.11	\$0.00	\$51.09
5	80	\$31.02	\$9.90	\$13.74	\$0.00	\$54.66
6	80	\$31.02	\$9.90	\$13.74	\$0.00	\$54.66
7	90	\$34.89	\$9.90	\$15.37	\$0.00	\$60.16
8	90	\$34.89	\$9.90	\$15.37	\$0.00	\$60.16

Effective Date - 09/01/2017

Step	percent	Apprentice Base Wage	Health	Pension	Supplemental Unemployment	Total Rate
1	50	\$19.89	\$9.90	\$1.63	\$0.00	\$31.42
2	60	\$23.87	\$9.90	\$1.63	\$0.00	\$35.40
3	70	\$27.85	\$9.90	\$12.11	\$0.00	\$49.86
4	75	\$29.84	\$9.90	\$12.11	\$0.00	\$51.85
5	80	\$31.82	\$9.90	\$13.74	\$0.00	\$55.46
6	80	\$31.82	\$9.90	\$13.74	\$0.00	\$55.46
7	90	\$35.80	\$9.90	\$15.37	\$0.00	\$61.07
8	90	\$35.80	\$9.90	\$15.37	\$0.00	\$61.07

Notes:

Apprentice to Journeyworker Ratio:1:5

CEMENT MASONRY/PLASTERING	01/01/2017	\$45.67	\$12.20	\$19.41	\$1.30	\$78.58
BRICKLAYERS LOCAL 3 (BOSTON)	07/01/2017	\$46.30	\$12.20	\$19.41	\$1.30	\$79.21
	01/01/2018	\$46.54	\$12.20	\$19.41	\$1.30	\$79.45
	07/01/2018	\$46.79	\$12.20	\$19.41	\$1.30	\$79.70
	01/01/2019	\$47.03	\$12.20	\$19.41	\$1.30	\$79.94
	07/01/2019	\$47.27	\$12.20	\$19.41	\$1.30	\$80.18
	01/01/2020	\$47.52	\$12.20	\$19.41	\$1.30	\$80.43

Classification

Effective Date Base Wage Health Pension Supplemental Unemployment Total Rate

Apprentice - CEMENT MASONRY/PLASTERING - Eastern Mass (Boston)

Effective Date - 01/01/2017

Step	percent	Apprentice Base Wage	Health	Pension	Supplemental Unemployment	Total Rate
1	50	\$22.84	\$12.20	\$12.41	\$0.00	\$47.45
2	60	\$27.40	\$12.20	\$14.41	\$1.30	\$55.31
3	65	\$29.69	\$12.20	\$15.41	\$1.30	\$58.60
4	70	\$31.97	\$12.20	\$16.41	\$1.30	\$61.88
5	75	\$34.25	\$12.20	\$17.41	\$1.30	\$65.16
6	80	\$36.54	\$12.20	\$18.41	\$1.30	\$68.45
7	90	\$41.10	\$12.20	\$19.41	\$1.30	\$74.01

Effective Date - 07/01/2017

Step	percent	Apprentice Base Wage	Health	Pension	Supplemental Unemployment	Total Rate
1	50	\$23.15	\$12.20	\$12.41	\$0.00	\$47.76
2	60	\$27.78	\$12.20	\$14.41	\$1.30	\$55.69
3	65	\$30.10	\$12.20	\$15.41	\$1.30	\$59.01
4	70	\$32.41	\$12.20	\$16.41	\$1.30	\$62.32
5	75	\$34.73	\$12.20	\$17.41	\$1.30	\$65.64
6	80	\$37.04	\$12.20	\$18.41	\$1.30	\$68.95
7	90	\$41.67	\$12.20	\$19.41	\$1.30	\$74.58

Notes:
Steps 3,4 are 500 hrs. All other steps are 1,000 hrs.

Apprentice to Journeyworker Ratio:1:3

CHAIN SAW OPERATOR LABORERS - ZONE 1	12/01/2016	\$36.60	\$7.60	\$14.15	\$0.00	\$58.35
	06/01/2017	\$37.60	\$7.60	\$14.15	\$0.00	\$59.35
	12/01/2017	\$38.45	\$7.60	\$14.15	\$0.00	\$60.20
	06/01/2018	\$39.40	\$7.60	\$14.15	\$0.00	\$61.15
	12/01/2018	\$40.35	\$7.60	\$14.15	\$0.00	\$62.10
	06/01/2019	\$41.35	\$7.60	\$14.15	\$0.00	\$63.10
	12/01/2019	\$42.35	\$7.60	\$14.15	\$0.00	\$64.10

For apprentice rates see "Apprentice- LABORER"

CLAM SHELLS/SLURRY BUCKETS/HEADING MACHINES OPERATING ENGINEERS LOCAL 4	12/01/2016	\$46.38	\$10.00	\$15.25	\$0.00	\$71.63
	06/01/2017	\$47.38	\$10.00	\$15.25	\$0.00	\$72.63
	12/01/2017	\$48.38	\$10.00	\$15.25	\$0.00	\$73.63

For apprentice rates see "Apprentice- OPERATING ENGINEERS"

COMPRESSOR OPERATOR OPERATING ENGINEERS LOCAL 4	12/01/2016	\$31.17	\$10.00	\$15.25	\$0.00	\$56.42
	06/01/2017	\$31.86	\$10.00	\$15.25	\$0.00	\$57.11
	12/01/2017	\$32.55	\$10.00	\$15.25	\$0.00	\$57.80

For apprentice rates see "Apprentice- OPERATING ENGINEERS"

DELEADER (BRIDGE) PAINTERS LOCAL 35 - ZONE 2	01/01/2017	\$51.41	\$7.85	\$16.10	\$0.00	\$75.36
---	------------	---------	--------	---------	--------	---------

Classification

Effective Date Base Wage Health Pension Supplemental Unemployment Total Rate

Apprentice - PAINTER Local 35 - BRIDGES/TANKS

Effective Date - 01/01/2017

Step	percent	Apprentice Base Wage	Health	Pension	Supplemental Unemployment	Total Rate
1	50	\$25.71	\$7.85	\$0.00	\$0.00	\$33.56
2	55	\$28.28	\$7.85	\$3.66	\$0.00	\$39.79
3	60	\$30.85	\$7.85	\$3.99	\$0.00	\$42.69
4	65	\$33.42	\$7.85	\$4.32	\$0.00	\$45.59
5	70	\$35.99	\$7.85	\$14.11	\$0.00	\$57.95
6	75	\$38.56	\$7.85	\$14.44	\$0.00	\$60.85
7	80	\$41.13	\$7.85	\$14.77	\$0.00	\$63.75
8	90	\$46.27	\$7.85	\$15.44	\$0.00	\$69.56

Notes:

Steps are 750 hrs.

Apprentice to Journeyworker Ratio:1:1

DEMO: ADZEMAN LABORERS - ZONE 1	12/01/2016	\$36.50	\$7.60	\$14.15	\$0.00	\$58.25
	06/01/2017	\$37.50	\$7.60	\$14.15	\$0.00	\$59.25
	12/01/2017	\$38.35	\$7.60	\$14.15	\$0.00	\$60.10
	06/01/2018	\$39.30	\$7.60	\$14.15	\$0.00	\$61.05
	12/01/2018	\$40.25	\$7.60	\$14.15	\$0.00	\$62.00
	06/01/2019	\$41.25	\$7.60	\$14.15	\$0.00	\$63.00
	12/01/2019	\$42.25	\$7.60	\$14.15	\$0.00	\$64.00

For apprentice rates see "Apprentice- LABORER"

DEMO: BACKHOE/LOADER/HAMMER OPERATOR LABORERS - ZONE 1	12/01/2016	\$37.50	\$7.60	\$14.15	\$0.00	\$59.25
	06/01/2017	\$38.50	\$7.60	\$14.15	\$0.00	\$60.25
	12/01/2017	\$39.35	\$7.60	\$14.15	\$0.00	\$61.10
	06/01/2018	\$40.30	\$7.60	\$14.15	\$0.00	\$62.05
	12/01/2018	\$41.25	\$7.60	\$14.15	\$0.00	\$63.00
	06/01/2019	\$42.25	\$7.60	\$14.15	\$0.00	\$64.00
	12/01/2019	\$43.25	\$7.60	\$14.15	\$0.00	\$65.00

For apprentice rates see "Apprentice- LABORER"

DEMO: BURNERS LABORERS - ZONE 1	12/01/2016	\$37.25	\$7.60	\$14.15	\$0.00	\$59.00
	06/01/2017	\$38.25	\$7.60	\$14.15	\$0.00	\$60.00
	12/01/2017	\$39.10	\$7.60	\$14.15	\$0.00	\$60.85
	06/01/2018	\$40.05	\$7.60	\$14.15	\$0.00	\$61.80
	12/01/2018	\$41.00	\$7.60	\$14.15	\$0.00	\$62.75
	06/01/2019	\$42.00	\$7.60	\$14.15	\$0.00	\$63.75
	12/01/2019	\$43.00	\$7.60	\$14.15	\$0.00	\$64.75

For apprentice rates see "Apprentice- LABORER"

Classification	Effective Date	Base Wage	Health	Pension	Supplemental Unemployment	Total Rate
DEMO: CONCRETE CUTTER/SAWYER <i>LABORERS - ZONE 1</i>	12/01/2016	\$37.50	\$7.60	\$14.15	\$0.00	\$59.25
	06/01/2017	\$38.50	\$7.60	\$14.15	\$0.00	\$60.25
	12/01/2017	\$39.35	\$7.60	\$14.15	\$0.00	\$61.10
	06/01/2018	\$40.30	\$7.60	\$14.15	\$0.00	\$62.05
	12/01/2018	\$41.25	\$7.60	\$14.15	\$0.00	\$63.00
	06/01/2019	\$42.25	\$7.60	\$14.15	\$0.00	\$64.00
	12/01/2019	\$43.25	\$7.60	\$14.15	\$0.00	\$65.00
For apprentice rates see "Apprentice- LABORER"						
DEMO: JACKHAMMER OPERATOR <i>LABORERS - ZONE 1</i>	12/01/2016	\$37.25	\$7.60	\$14.15	\$0.00	\$59.00
	06/01/2017	\$38.25	\$7.60	\$14.15	\$0.00	\$60.00
	12/01/2017	\$39.10	\$7.60	\$14.15	\$0.00	\$60.85
	06/01/2018	\$40.05	\$7.60	\$14.15	\$0.00	\$61.80
	12/01/2018	\$41.00	\$7.60	\$14.15	\$0.00	\$62.75
	06/01/2019	\$42.00	\$7.60	\$14.15	\$0.00	\$63.75
	12/01/2019	\$43.00	\$7.60	\$14.15	\$0.00	\$64.75
For apprentice rates see "Apprentice- LABORER"						
DEMO: WRECKING LABORER <i>LABORERS - ZONE 1</i>	12/01/2016	\$36.50	\$7.60	\$14.15	\$0.00	\$58.25
	06/01/2017	\$37.50	\$7.60	\$14.15	\$0.00	\$59.25
	12/01/2017	\$38.35	\$7.60	\$14.15	\$0.00	\$60.10
	06/01/2018	\$39.30	\$7.60	\$14.15	\$0.00	\$61.05
	12/01/2018	\$40.25	\$7.60	\$14.15	\$0.00	\$62.00
	06/01/2019	\$41.25	\$7.60	\$14.15	\$0.00	\$63.00
	12/01/2019	\$42.25	\$7.60	\$14.15	\$0.00	\$64.00
For apprentice rates see "Apprentice- LABORER"						
DIRECTIONAL DRILL MACHINE OPERATOR <i>OPERATING ENGINEERS LOCAL 4</i>	12/01/2016	\$44.94	\$10.00	\$15.25	\$0.00	\$70.19
	06/01/2017	\$45.93	\$10.00	\$15.25	\$0.00	\$71.18
	12/01/2017	\$46.92	\$10.00	\$15.25	\$0.00	\$72.17
For apprentice rates see "Apprentice- OPERATING ENGINEERS"						
DIVER <i>PILE DRIVER LOCAL 56 (ZONE 1)</i>	08/01/2015	\$58.86	\$9.80	\$19.23	\$0.00	\$87.89
For apprentice rates see "Apprentice- PILE DRIVER"						
DIVER TENDER <i>PILE DRIVER LOCAL 56 (ZONE 1)</i>	08/01/2015	\$42.04	\$9.80	\$19.23	\$0.00	\$71.07
For apprentice rates see "Apprentice- PILE DRIVER"						
DIVER TENDER (EFFLUENT) <i>PILE DRIVER LOCAL 56 (ZONE 1)</i>	08/01/2015	\$63.06	\$9.80	\$19.23	\$0.00	\$92.09
For apprentice rates see "Apprentice- PILE DRIVER"						
DIVER/SLURRY (EFFLUENT) <i>PILE DRIVER LOCAL 56 (ZONE 1)</i>	08/01/2015	\$88.23	\$9.80	\$19.23	\$0.00	\$117.26
For apprentice rates see "Apprentice- PILE DRIVER"						
DRAWBRIDGE OPERATOR (Construction) <i>ELECTRICIANS LOCAL 103</i>	03/01/2017	\$48.33	\$13.00	\$17.45	\$0.00	\$78.78
	09/01/2017	\$49.28	\$13.00	\$17.48	\$0.00	\$79.76
	03/01/2018	\$50.48	\$13.00	\$17.51	\$0.00	\$80.99
	09/01/2018	\$51.67	\$13.00	\$17.55	\$0.00	\$82.22
	03/01/2019	\$52.87	\$13.00	\$17.59	\$0.00	\$83.46
For apprentice rates see "Apprentice- ELECTRICIAN"						

Classification	Effective Date	Base Wage	Health	Pension	Supplemental Unemployment	Total Rate
ELECTRICIAN ELECTRICIANS LOCAL 103	03/01/2017	\$48.33	\$13.00	\$17.45	\$0.00	\$78.78
	09/01/2017	\$49.28	\$13.00	\$17.48	\$0.00	\$79.76
	03/01/2018	\$50.48	\$13.00	\$17.51	\$0.00	\$80.99
	09/01/2018	\$51.67	\$13.00	\$17.55	\$0.00	\$82.22
	03/01/2019	\$52.87	\$13.00	\$17.59	\$0.00	\$83.46

Apprentice - ELECTRICIAN - Local 103

Effective Date - 03/01/2017

Step	percent	Apprentice Base Wage	Health	Pension	Supplemental Unemployment	Total Rate
1	40	\$19.33	\$13.00	\$0.58	\$0.00	\$32.91
2	40	\$19.33	\$13.00	\$0.58	\$0.00	\$32.91
3	45	\$21.75	\$13.00	\$13.37	\$0.00	\$48.12
4	45	\$21.75	\$13.00	\$13.37	\$0.00	\$48.12
5	50	\$24.17	\$13.00	\$13.75	\$0.00	\$50.92
6	55	\$26.58	\$13.00	\$14.11	\$0.00	\$53.69
7	60	\$29.00	\$13.00	\$14.48	\$0.00	\$56.48
8	65	\$31.41	\$13.00	\$14.85	\$0.00	\$59.26
9	70	\$33.83	\$13.00	\$15.22	\$0.00	\$62.05
10	75	\$36.25	\$13.00	\$15.60	\$0.00	\$64.85

Effective Date - 09/01/2017

Step	percent	Apprentice Base Wage	Health	Pension	Supplemental Unemployment	Total Rate
1	40	\$19.71	\$13.00	\$0.59	\$0.00	\$33.30
2	40	\$19.71	\$13.00	\$0.59	\$0.00	\$33.30
3	45	\$22.18	\$13.00	\$13.39	\$0.00	\$48.57
4	45	\$22.18	\$13.00	\$13.39	\$0.00	\$48.57
5	50	\$24.64	\$13.00	\$13.76	\$0.00	\$51.40
6	55	\$27.10	\$13.00	\$14.12	\$0.00	\$54.22
7	60	\$29.57	\$13.00	\$14.50	\$0.00	\$57.07
8	65	\$32.03	\$13.00	\$14.87	\$0.00	\$59.90
9	70	\$34.50	\$13.00	\$15.25	\$0.00	\$62.75
10	75	\$36.96	\$13.00	\$15.62	\$0.00	\$65.58

Notes :

App Prior 1/1/03; 30/35/40/45/50/55/65/70/75/80

Apprentice to Journeyworker Ratio:2:3***

ELEVATOR CONSTRUCTOR ELEVATOR CONSTRUCTORS LOCAL 4	01/01/2017	\$55.86	\$15.28	\$15.71	\$0.00	\$86.85
---	------------	---------	---------	---------	--------	---------

Classification

Effective Date Base Wage Health Pension Supplemental Unemployment Total Rate

Apprentice - ELEVATOR CONSTRUCTOR - Local 4

Effective Date - 01/01/2017

Step	percent	Apprentice Base Wage	Health	Pension	Supplemental Unemployment	Total Rate
1	50	\$27.93	\$15.28	\$0.00	\$0.00	\$43.21
2	55	\$30.72	\$15.28	\$15.71	\$0.00	\$61.71
3	65	\$36.31	\$15.28	\$15.71	\$0.00	\$67.30
4	70	\$39.10	\$15.28	\$15.71	\$0.00	\$70.09
5	80	\$44.69	\$15.28	\$15.71	\$0.00	\$75.68

Notes:

Steps 1-2 are 6 mos.; Steps 3-5 are 1 year

Apprentice to Journeyworker Ratio:1:1

ELEVATOR CONSTRUCTOR HELPER <i>ELEVATOR CONSTRUCTORS LOCAL 4</i>	01/01/2017	\$39.10	\$15.28	\$15.71	\$0.00	\$70.09
---	------------	---------	---------	---------	--------	---------

For apprentice rates see "Apprentice - ELEVATOR CONSTRUCTOR"

FENCE & GUARD RAIL ERECTOR <i>LABORERS - ZONE 1</i>	12/01/2016	\$36.60	\$7.60	\$14.15	\$0.00	\$58.35
	06/01/2017	\$37.60	\$7.60	\$14.15	\$0.00	\$59.35
	12/01/2017	\$38.45	\$7.60	\$14.15	\$0.00	\$60.20
	06/01/2018	\$39.40	\$7.60	\$14.15	\$0.00	\$61.15
	12/01/2018	\$40.35	\$7.60	\$14.15	\$0.00	\$62.10
	06/01/2019	\$41.35	\$7.60	\$14.15	\$0.00	\$63.10
	12/01/2019	\$42.35	\$7.60	\$14.15	\$0.00	\$64.10

For apprentice rates see "Apprentice- LABORER"

FIELD ENG.INST.PERSON-BLDG,SITE,HVY/HWY <i>OPERATING ENGINEERS LOCAL 4</i>	05/01/2017	\$42.15	\$10.00	\$15.25	\$0.00	\$67.40
	11/01/2017	\$42.88	\$10.00	\$15.25	\$0.00	\$68.13
	05/01/2018	\$43.59	\$10.00	\$15.25	\$0.00	\$68.84

For apprentice rates see "Apprentice- OPERATING ENGINEERS"

FIELD ENG.PARTY CHIEF-BLDG,SITE,HVY/HWY <i>OPERATING ENGINEERS LOCAL 4</i>	05/01/2017	\$43.61	\$10.00	\$15.25	\$0.00	\$68.86
	11/01/2017	\$44.34	\$10.00	\$15.25	\$0.00	\$69.59
	05/01/2018	\$45.06	\$10.00	\$15.25	\$0.00	\$70.31

For apprentice rates see "Apprentice- OPERATING ENGINEERS"

FIELD ENG.ROD PERSON-BLDG,SITE,HVY/HWY <i>OPERATING ENGINEERS LOCAL 4</i>	05/01/2017	\$22.41	\$10.00	\$15.25	\$0.00	\$47.66
	11/01/2017	\$22.83	\$10.00	\$15.25	\$0.00	\$48.08
	05/01/2018	\$23.26	\$10.00	\$15.25	\$0.00	\$48.51

For apprentice rates see "Apprentice- OPERATING ENGINEERS"

FIRE ALARM INSTALLER <i>ELECTRICIANS LOCAL 103</i>	03/01/2017	\$48.33	\$13.00	\$17.45	\$0.00	\$78.78
	09/01/2017	\$49.28	\$13.00	\$17.48	\$0.00	\$79.76
	03/01/2018	\$50.48	\$13.00	\$17.51	\$0.00	\$80.99
	09/01/2018	\$51.67	\$13.00	\$17.55	\$0.00	\$82.22
	03/01/2019	\$52.87	\$13.00	\$17.59	\$0.00	\$83.46

For apprentice rates see "Apprentice- ELECTRICIAN"

Classification	Effective Date	Base Wage	Health	Pension	Supplemental Unemployment	Total Rate
FIRE ALARM REPAIR / MAINTENANCE / COMMISSIONING <i>ELECTRICIANS</i>	03/01/2017	\$36.25	\$13.00	\$15.60	\$0.00	\$64.85
<i>LOCAL 103</i>	09/01/2017	\$36.96	\$13.00	\$15.62	\$0.00	\$65.58
	03/01/2018	\$37.86	\$13.00	\$15.65	\$0.00	\$66.51
	09/01/2018	\$38.75	\$13.00	\$15.67	\$0.00	\$67.42
	03/01/2019	\$39.65	\$13.00	\$15.70	\$0.00	\$68.35
For apprentice rates see "Apprentice- TELECOMMUNICATIONS TECHNICIAN"						
FIREMAN (ASST. ENGINEER) <i>OPERATING ENGINEERS LOCAL 4</i>	12/01/2016	\$37.65	\$10.00	\$15.25	\$0.00	\$62.90
	06/01/2017	\$38.49	\$10.00	\$15.25	\$0.00	\$63.74
	12/01/2017	\$39.32	\$10.00	\$15.25	\$0.00	\$64.57
For apprentice rates see "Apprentice- OPERATING ENGINEERS"						
FLAGGER & SIGNALER <i>LABORERS - ZONE 1</i>	12/01/2016	\$20.50	\$7.60	\$14.15	\$0.00	\$42.25
For apprentice rates see "Apprentice- LABORER"						
FLOORCOVERER <i>FLOORCOVERERS LOCAL 2168 ZONE 1</i>	03/01/2016	\$42.13	\$9.80	\$17.62	\$0.00	\$69.55

Apprentice - FLOORCOVERER - Local 2168 Zone 1

Effective Date - 03/01/2016

Step	percent	Apprentice Base Wage	Health	Pension	Supplemental Unemployment	Total Rate
1	50	\$21.07	\$9.80	\$1.79	\$0.00	\$32.66
2	55	\$23.17	\$9.80	\$1.79	\$0.00	\$34.76
3	60	\$25.28	\$9.80	\$12.25	\$0.00	\$47.33
4	65	\$27.38	\$9.80	\$12.25	\$0.00	\$49.43
5	70	\$29.49	\$9.80	\$14.04	\$0.00	\$53.33
6	75	\$31.60	\$9.80	\$14.04	\$0.00	\$55.44
7	80	\$33.70	\$9.80	\$15.83	\$0.00	\$59.33
8	85	\$35.81	\$9.80	\$15.83	\$0.00	\$61.44

Notes:

Steps are 750 hrs.

Apprentice to Journeyworker Ratio:1:1

FORK LIFT/CHERRY PICKER <i>OPERATING ENGINEERS LOCAL 4</i>	12/01/2016	\$45.38	\$10.00	\$15.25	\$0.00	\$70.63
	06/01/2017	\$46.38	\$10.00	\$15.25	\$0.00	\$71.63
	12/01/2017	\$47.38	\$10.00	\$15.25	\$0.00	\$72.63
For apprentice rates see "Apprentice- OPERATING ENGINEERS"						
GENERATOR/LIGHTING PLANT/HEATERS <i>OPERATING ENGINEERS LOCAL 4</i>	12/01/2016	\$31.17	\$10.00	\$15.25	\$0.00	\$56.42
	06/01/2017	\$31.86	\$10.00	\$15.25	\$0.00	\$57.11
	12/01/2017	\$32.55	\$10.00	\$15.25	\$0.00	\$57.80
For apprentice rates see "Apprentice- OPERATING ENGINEERS"						
GLAZIER (GLASS PLANK/AIR BARRIER/INTERIOR SYSTEMS) <i>GLAZIERS LOCAL 35 (ZONE 2)</i>	01/01/2017	\$40.91	\$7.85	\$16.10	\$0.00	\$64.86

Classification

Effective Date Base Wage Health Pension Supplemental Unemployment Total Rate

Apprentice - GLAZIER - Local 35 Zone 2

Effective Date - 01/01/2017

Step	percent	Apprentice Base Wage	Health	Pension	Supplemental Unemployment	Total Rate
1	50	\$20.46	\$7.85	\$0.00	\$0.00	\$28.31
2	55	\$22.50	\$7.85	\$3.66	\$0.00	\$34.01
3	60	\$24.55	\$7.85	\$3.99	\$0.00	\$36.39
4	65	\$26.59	\$7.85	\$4.32	\$0.00	\$38.76
5	70	\$28.64	\$7.85	\$14.11	\$0.00	\$50.60
6	75	\$30.68	\$7.85	\$14.44	\$0.00	\$52.97
7	80	\$32.73	\$7.85	\$14.77	\$0.00	\$55.35
8	90	\$36.82	\$7.85	\$15.44	\$0.00	\$60.11

Notes:
Steps are 750 hrs.

Apprentice to Journeyworker Ratio:1:1

HOISTING ENGINEER/CRANES/GRADALLS	12/01/2016	\$45.38	\$10.00	\$15.25	\$0.00	\$70.63
OPERATING ENGINEERS LOCAL 4	06/01/2017	\$46.38	\$10.00	\$15.25	\$0.00	\$71.63
	12/01/2017	\$47.38	\$10.00	\$15.25	\$0.00	\$72.63

Classification

Effective Date Base Wage Health Pension Supplemental Unemployment Total Rate

Apprentice - OPERATING ENGINEERS - Local 4

Effective Date - 12/01/2016

Step	percent	Apprentice Base Wage	Health	Pension	Supplemental Unemployment	Total Rate
1	55	\$24.96	\$10.00	\$0.00	\$0.00	\$34.96
2	60	\$27.23	\$10.00	\$15.25	\$0.00	\$52.48
3	65	\$29.50	\$10.00	\$15.25	\$0.00	\$54.75
4	70	\$31.77	\$10.00	\$15.25	\$0.00	\$57.02
5	75	\$34.04	\$10.00	\$15.25	\$0.00	\$59.29
6	80	\$36.30	\$10.00	\$15.25	\$0.00	\$61.55
7	85	\$38.57	\$10.00	\$15.25	\$0.00	\$63.82
8	90	\$40.84	\$10.00	\$15.25	\$0.00	\$66.09

Effective Date - 06/01/2017

Step	percent	Apprentice Base Wage	Health	Pension	Supplemental Unemployment	Total Rate
1	55	\$25.51	\$10.00	\$0.00	\$0.00	\$35.51
2	60	\$27.83	\$10.00	\$15.25	\$0.00	\$53.08
3	65	\$30.15	\$10.00	\$15.25	\$0.00	\$55.40
4	70	\$32.47	\$10.00	\$15.25	\$0.00	\$57.72
5	75	\$34.79	\$10.00	\$15.25	\$0.00	\$60.04
6	80	\$37.10	\$10.00	\$15.25	\$0.00	\$62.35
7	85	\$39.42	\$10.00	\$15.25	\$0.00	\$64.67
8	90	\$41.74	\$10.00	\$15.25	\$0.00	\$66.99

Notes:

Apprentice to Journeyworker Ratio:1:6

HVAC (DUCTWORK) SHEETMETAL WORKERS LOCAL 17 - A	02/01/2017	\$43.72	\$11.45	\$23.07	\$2.35	\$80.59
	08/01/2017	\$44.82	\$11.45	\$23.07	\$2.35	\$81.69
	02/01/2018	\$45.97	\$11.45	\$23.07	\$2.35	\$82.84

For apprentice rates see "Apprentice- SHEET METAL WORKER"

HVAC (ELECTRICAL CONTROLS) ELECTRICIANS LOCAL 103	03/01/2017	\$48.33	\$13.00	\$17.45	\$0.00	\$78.78
	09/01/2017	\$49.28	\$13.00	\$17.48	\$0.00	\$79.76
	03/01/2018	\$50.48	\$13.00	\$17.51	\$0.00	\$80.99
	09/01/2018	\$51.67	\$13.00	\$17.55	\$0.00	\$82.22
	03/01/2019	\$52.87	\$13.00	\$17.59	\$0.00	\$83.46

For apprentice rates see "Apprentice- ELECTRICIAN"

HVAC (TESTING AND BALANCING - AIR) SHEETMETAL WORKERS LOCAL 17 - A	02/01/2017	\$43.72	\$11.45	\$23.07	\$2.35	\$80.59
	08/01/2017	\$44.82	\$11.45	\$23.07	\$2.35	\$81.69
	02/01/2018	\$45.97	\$11.45	\$23.07	\$2.35	\$82.84

For apprentice rates see "Apprentice- SHEET METAL WORKER"

HVAC (TESTING AND BALANCING -WATER) PIPEFITTERS LOCAL 537	03/01/2017	\$51.19	\$9.70	\$18.14	\$0.00	\$79.03
--	------------	---------	--------	---------	--------	---------

For apprentice rates see "Apprentice- PIPEFITTER" or "PLUMBER/PIPEFITTER"

HVAC MECHANIC PIPEFITTERS LOCAL 537	03/01/2017	\$51.19	\$9.70	\$18.14	\$0.00	\$79.03
--	------------	---------	--------	---------	--------	---------

Classification	Effective Date	Base Wage	Health	Pension	Supplemental Unemployment	Total Rate
For apprentice rates see "Apprentice- PIPEFITTER" or "PLUMBER/PIPEFITTER"						
HYDRAULIC DRILLS LABORERS - ZONE 1	12/01/2016	\$37.10	\$7.60	\$14.15	\$0.00	\$58.85
	06/01/2017	\$38.10	\$7.60	\$14.15	\$0.00	\$59.85
	12/01/2017	\$38.95	\$7.60	\$14.15	\$0.00	\$60.70
	06/01/2018	\$39.90	\$7.60	\$14.15	\$0.00	\$61.65
	12/01/2018	\$40.85	\$7.60	\$14.15	\$0.00	\$62.60
	06/01/2019	\$41.85	\$7.60	\$14.15	\$0.00	\$63.60
	12/01/2019	\$42.85	\$7.60	\$14.15	\$0.00	\$64.60

For apprentice rates see "Apprentice- LABORER"						
INSULATOR (PIPES & TANKS) HEAT & FROST INSULATORS LOCAL 6 (BOSTON)	09/01/2016	\$45.09	\$11.75	\$14.20	\$0.00	\$71.04
	09/01/2017	\$47.09	\$11.75	\$14.20	\$0.00	\$73.04
	09/01/2018	\$49.34	\$11.75	\$14.20	\$0.00	\$75.29
	09/01/2019	\$51.84	\$11.75	\$14.20	\$0.00	\$77.79

Apprentice - ASBESTOS INSULATOR (Pipes & Tanks) - Local 6 Boston

Effective Date - 09/01/2016

Step	percent	Apprentice Base Wage	Health	Pension	Supplemental Unemployment	Total Rate
1	50	\$22.55	\$11.75	\$10.45	\$0.00	\$44.75
2	60	\$27.05	\$11.75	\$11.20	\$0.00	\$50.00
3	70	\$31.56	\$11.75	\$11.95	\$0.00	\$55.26
4	80	\$36.07	\$11.75	\$12.70	\$0.00	\$60.52

Effective Date - 09/01/2017

Step	percent	Apprentice Base Wage	Health	Pension	Supplemental Unemployment	Total Rate
1	50	\$23.55	\$11.75	\$10.45	\$0.00	\$45.75
2	60	\$28.25	\$11.75	\$11.20	\$0.00	\$51.20
3	70	\$32.96	\$11.75	\$11.95	\$0.00	\$56.66
4	80	\$37.67	\$11.75	\$12.70	\$0.00	\$62.12

Notes:

Steps are 1 year

Apprentice to Journeyworker Ratio:1:4

IRONWORKER/WELDER IRONWORKERS LOCAL 7 (BOSTON AREA)	03/16/2017	\$44.65	\$7.80	\$20.85	\$0.00	\$73.30
--	------------	---------	--------	---------	--------	---------

Classification

Effective Date Base Wage Health Pension Supplemental Unemployment Total Rate

Apprentice - IRONWORKER - Local 7 Boston

Effective Date - 03/16/2017

Step	percent	Apprentice Base Wage	Health	Pension	Supplemental Unemployment	Total Rate
1	60	\$26.79	\$7.80	\$20.85	\$0.00	\$55.44
2	70	\$31.26	\$7.80	\$20.85	\$0.00	\$59.91
3	75	\$33.49	\$7.80	\$20.85	\$0.00	\$62.14
4	80	\$35.72	\$7.80	\$20.85	\$0.00	\$64.37
5	85	\$37.95	\$7.80	\$20.85	\$0.00	\$66.60
6	90	\$40.19	\$7.80	\$20.85	\$0.00	\$68.84

Notes:

** Structural 1:6; Ornamental 1:4

Apprentice to Journeyworker Ratio:**

JACKHAMMER & PAVING BREAKER OPERATOR LABORERS - ZONE 1	12/01/2016	\$36.60	\$7.60	\$14.15	\$0.00	\$58.35
	06/01/2017	\$37.60	\$7.60	\$14.15	\$0.00	\$59.35
	12/01/2017	\$38.45	\$7.60	\$14.15	\$0.00	\$60.20
	06/01/2018	\$39.40	\$7.60	\$14.15	\$0.00	\$61.15
	12/01/2018	\$40.35	\$7.60	\$14.15	\$0.00	\$62.10
	06/01/2019	\$41.35	\$7.60	\$14.15	\$0.00	\$63.10
	12/01/2019	\$42.35	\$7.60	\$14.15	\$0.00	\$64.10

For apprentice rates see "Apprentice- LABORER"

LABORER LABORERS - ZONE 1	12/01/2016	\$36.35	\$7.60	\$14.15	\$0.00	\$58.10
	06/01/2017	\$37.35	\$7.60	\$14.15	\$0.00	\$59.10
	12/01/2017	\$38.20	\$7.60	\$14.15	\$0.00	\$59.95
	06/01/2018	\$39.15	\$7.60	\$14.15	\$0.00	\$60.90
	12/01/2018	\$40.10	\$7.60	\$14.15	\$0.00	\$61.85
	06/01/2019	\$41.10	\$7.60	\$14.15	\$0.00	\$62.85
	12/01/2019	\$42.10	\$7.60	\$14.15	\$0.00	\$63.85

Classification

Effective Date Base Wage Health Pension Supplemental Unemployment Total Rate

Apprentice - LABORER - Zone 1

Effective Date - 12/01/2016

Step	percent	Apprentice Base Wage	Health	Pension	Supplemental Unemployment	Total Rate
1	60	\$21.81	\$7.60	\$14.15	\$0.00	\$43.56
2	70	\$25.45	\$7.60	\$14.15	\$0.00	\$47.20
3	80	\$29.08	\$7.60	\$14.15	\$0.00	\$50.83
4	90	\$32.72	\$7.60	\$14.15	\$0.00	\$54.47

Effective Date - 06/01/2017

Step	percent	Apprentice Base Wage	Health	Pension	Supplemental Unemployment	Total Rate
1	60	\$22.41	\$7.60	\$14.15	\$0.00	\$44.16
2	70	\$26.15	\$7.60	\$14.15	\$0.00	\$47.90
3	80	\$29.88	\$7.60	\$14.15	\$0.00	\$51.63
4	90	\$33.62	\$7.60	\$14.15	\$0.00	\$55.37

Notes:

Apprentice to Journeyworker Ratio:1:5

LABORER: CARPENTER TENDER LABORERS - ZONE 1	12/01/2016	\$36.35	\$7.60	\$14.15	\$0.00	\$58.10
	06/01/2017	\$37.35	\$7.60	\$14.15	\$0.00	\$59.10
	12/01/2017	\$38.20	\$7.60	\$14.15	\$0.00	\$59.95
	06/01/2018	\$39.15	\$7.60	\$14.15	\$0.00	\$60.90
	12/01/2018	\$40.10	\$7.60	\$14.15	\$0.00	\$61.85
	06/01/2019	\$41.10	\$7.60	\$14.15	\$0.00	\$62.85
	12/01/2019	\$42.10	\$7.60	\$14.15	\$0.00	\$63.85

For apprentice rates see "Apprentice- LABORER"

LABORER: CEMENT FINISHER TENDER LABORERS - ZONE 1	12/01/2016	\$36.35	\$7.60	\$14.15	\$0.00	\$58.10
	06/01/2017	\$37.35	\$7.60	\$14.15	\$0.00	\$59.10
	12/01/2017	\$38.20	\$7.60	\$14.15	\$0.00	\$59.95
	06/01/2018	\$39.15	\$7.60	\$14.15	\$0.00	\$60.90
	12/01/2018	\$40.10	\$7.60	\$14.15	\$0.00	\$61.85
	06/01/2019	\$41.10	\$7.60	\$14.15	\$0.00	\$62.85
	12/01/2019	\$42.10	\$7.60	\$14.15	\$0.00	\$63.85

For apprentice rates see "Apprentice- LABORER"

LABORER: HAZARDOUS WASTE/ASBESTOS REMOVER LABORERS - ZONE 1	12/01/2016	\$36.50	\$7.60	\$14.15	\$0.00	\$58.25
	06/01/2017	\$37.50	\$7.60	\$14.15	\$0.00	\$59.25
	12/01/2017	\$38.35	\$7.60	\$14.15	\$0.00	\$60.10
	06/01/2018	\$39.30	\$7.60	\$14.15	\$0.00	\$61.05
	12/01/2018	\$40.25	\$7.60	\$14.15	\$0.00	\$62.00
	06/01/2019	\$41.25	\$7.60	\$14.15	\$0.00	\$63.00
	12/01/2019	\$42.28	\$7.60	\$14.15	\$0.00	\$64.03

For apprentice rates see "Apprentice- LABORER"

Classification	Effective Date	Base Wage	Health	Pension	Supplemental Unemployment	Total Rate
LABORER: MASON TENDER <i>LABORERS - ZONE 1</i>	12/01/2016	\$36.60	\$7.60	\$14.15	\$0.00	\$58.35
	06/01/2017	\$37.60	\$7.60	\$14.15	\$0.00	\$59.35
	12/01/2017	\$38.45	\$7.60	\$14.15	\$0.00	\$60.20
	06/01/2018	\$39.40	\$7.60	\$14.15	\$0.00	\$61.15
	12/01/2018	\$40.35	\$7.60	\$14.15	\$0.00	\$62.10
	06/01/2019	\$41.35	\$7.60	\$14.15	\$0.00	\$63.10
	12/01/2019	\$42.35	\$7.60	\$14.15	\$0.00	\$64.10
For apprentice rates see "Apprentice- LABORER"						
LABORER: MULTI-TRADE TENDER <i>LABORERS - ZONE 1</i>	12/01/2016	\$36.35	\$7.60	\$14.15	\$0.00	\$58.10
	06/01/2017	\$37.35	\$7.60	\$14.15	\$0.00	\$59.10
	12/01/2017	\$38.20	\$7.60	\$14.15	\$0.00	\$59.95
	06/01/2018	\$39.15	\$7.60	\$14.15	\$0.00	\$60.90
	12/01/2018	\$40.10	\$7.60	\$14.15	\$0.00	\$61.85
	06/01/2019	\$41.10	\$7.60	\$14.15	\$0.00	\$62.85
	12/01/2019	\$42.10	\$7.60	\$14.15	\$0.00	\$63.85
For apprentice rates see "Apprentice- LABORER"						
LABORER: TREE REMOVER <i>LABORERS - ZONE 1</i>	12/01/2016	\$36.35	\$7.60	\$14.15	\$0.00	\$58.10
	06/01/2017	\$37.35	\$7.60	\$14.15	\$0.00	\$59.10
	12/01/2017	\$38.20	\$7.60	\$14.15	\$0.00	\$59.95
	06/01/2018	\$39.15	\$7.60	\$14.15	\$0.00	\$60.90
	12/01/2018	\$40.10	\$7.60	\$14.15	\$0.00	\$61.85
	06/01/2019	\$41.10	\$7.60	\$14.15	\$0.00	\$62.85
	12/01/2019	\$42.10	\$7.60	\$14.15	\$0.00	\$63.85
This classification applies to all tree work associated with the removal of standing trees, and trimming and removal of branches and limbs when the work is not done for a utility company for the purpose of operation, maintenance or repair of utility company equipment. For apprentice rates see "Apprentice- LABORER"						
LASER BEAM OPERATOR <i>LABORERS - ZONE 1</i>	12/01/2016	\$36.60	\$7.60	\$14.15	\$0.00	\$58.35
	06/01/2017	\$37.60	\$7.60	\$14.15	\$0.00	\$59.35
	12/01/2017	\$38.45	\$7.60	\$14.15	\$0.00	\$60.20
	06/01/2018	\$39.40	\$7.60	\$14.15	\$0.00	\$61.15
	12/01/2018	\$40.35	\$7.60	\$14.15	\$0.00	\$62.10
	06/01/2019	\$41.35	\$7.60	\$14.15	\$0.00	\$63.10
	12/01/2019	\$42.35	\$7.60	\$14.15	\$0.00	\$64.10
For apprentice rates see "Apprentice- LABORER"						
MARBLE & TILE FINISHERS <i>BRICKLAYERS LOCAL 3 - MARBLE & TILE</i>	02/01/2017	\$38.78	\$10.75	\$17.67	\$0.00	\$67.20

Classification

Effective Date Base Wage Health Pension Supplemental Unemployment Total Rate

Apprentice - MARBLE & TILE FINISHER - Local 3 Marble & Tile

Effective Date - 02/01/2017

Step	percent	Apprentice Base Wage	Health	Pension	Supplemental Unemployment	Total Rate
1	50	\$19.39	\$10.75	\$17.67	\$0.00	\$47.81
2	60	\$23.27	\$10.75	\$17.67	\$0.00	\$51.69
3	70	\$27.15	\$10.75	\$17.67	\$0.00	\$55.57
4	80	\$31.02	\$10.75	\$17.67	\$0.00	\$59.44
5	90	\$34.90	\$10.75	\$17.67	\$0.00	\$63.32

Notes:

Apprentice to Journeyworker Ratio:1:3

MARBLE MASONS, TILELAYERS & TERRAZZO MECH BRICKLAYERS LOCAL 3 - MARBLE & TILE	02/01/2017	\$50.80	\$10.75	\$19.22	\$0.00	\$80.77
--	------------	---------	---------	---------	--------	---------

Apprentice - MARBLE-TILE-TERRAZZO MECHANIC - Local 3 Marble & Tile

Effective Date - 02/01/2017

Step	percent	Apprentice Base Wage	Health	Pension	Supplemental Unemployment	Total Rate
1	50	\$25.40	\$10.75	\$19.22	\$0.00	\$55.37
2	60	\$30.48	\$10.75	\$19.22	\$0.00	\$60.45
3	70	\$35.56	\$10.75	\$19.22	\$0.00	\$65.53
4	80	\$40.64	\$10.75	\$19.22	\$0.00	\$70.61
5	90	\$45.72	\$10.75	\$19.22	\$0.00	\$75.69

Notes:

Apprentice to Journeyworker Ratio:1:5

MECH. SWEEPER OPERATOR (ON CONST. SITES) OPERATING ENGINEERS LOCAL 4	12/01/2016	\$44.94	\$10.00	\$15.25	\$0.00	\$70.19
	06/01/2017	\$45.93	\$10.00	\$15.25	\$0.00	\$71.18
	12/01/2017	\$46.92	\$10.00	\$15.25	\$0.00	\$72.17

For apprentice rates see "Apprentice- OPERATING ENGINEERS"

MECHANICS MAINTENANCE OPERATING ENGINEERS LOCAL 4	12/01/2016	\$44.94	\$10.00	\$15.25	\$0.00	\$70.19
	06/01/2017	\$45.93	\$10.00	\$15.25	\$0.00	\$71.18
	12/01/2017	\$46.92	\$10.00	\$15.25	\$0.00	\$72.17

For apprentice rates see "Apprentice- OPERATING ENGINEERS"

MILLWRIGHT (Zone 1) MILLWRIGHTS LOCAL 1121 - Zone 1	04/01/2017	\$38.62	\$9.90	\$18.50	\$0.00	\$67.02
	10/01/2017	\$39.52	\$9.90	\$18.50	\$0.00	\$67.92
	04/01/2018	\$40.42	\$9.90	\$18.50	\$0.00	\$68.82
	10/01/2018	\$41.32	\$9.90	\$18.50	\$0.00	\$69.72
	04/01/2019	\$42.22	\$9.90	\$18.50	\$0.00	\$70.62

Classification

Effective Date Base Wage Health Pension Supplemental Unemployment Total Rate

Apprentice - MILLWRIGHT - Local 1121 Zone 1

Effective Date - 04/01/2017

Step	percent	Apprentice Base Wage	Health	Pension	Supplemental Unemployment	Total Rate
1	55	\$21.24	\$9.90	\$5.31	\$0.00	\$36.45
2	65	\$25.10	\$9.90	\$15.13	\$0.00	\$50.13
3	75	\$28.97	\$9.90	\$16.10	\$0.00	\$54.97
4	85	\$32.83	\$9.90	\$17.06	\$0.00	\$59.79

Effective Date - 10/01/2017

Step	percent	Apprentice Base Wage	Health	Pension	Supplemental Unemployment	Total Rate
1	55	\$21.74	\$9.90	\$5.31	\$0.00	\$36.95
2	65	\$25.69	\$9.90	\$15.13	\$0.00	\$50.72
3	75	\$29.64	\$9.90	\$16.10	\$0.00	\$55.64
4	85	\$33.59	\$9.90	\$17.06	\$0.00	\$60.55

Notes:

Steps are 2,000 hours

Apprentice to Journeyworker Ratio:1:5

MORTAR MIXER LABORERS - ZONE 1	12/01/2016	\$36.60	\$7.60	\$14.15	\$0.00	\$58.35
	06/01/2017	\$37.60	\$7.60	\$14.15	\$0.00	\$59.35
	12/01/2017	\$38.45	\$7.60	\$14.15	\$0.00	\$60.20
	06/01/2018	\$39.40	\$7.60	\$14.15	\$0.00	\$61.15
	12/01/2018	\$40.35	\$7.60	\$14.15	\$0.00	\$62.10
	06/01/2019	\$41.35	\$7.60	\$14.15	\$0.00	\$63.10
	12/01/2019	\$42.35	\$7.60	\$14.15	\$0.00	\$64.10

For apprentice rates see "Apprentice- LABORER"

OILER (OTHER THAN TRUCK CRANES, GRADALLS) OPERATING ENGINEERS LOCAL 4	12/01/2016	\$22.96	\$10.00	\$15.25	\$0.00	\$48.21
	06/01/2017	\$23.47	\$10.00	\$15.25	\$0.00	\$48.72
	12/01/2017	\$23.99	\$10.00	\$15.25	\$0.00	\$49.24

For apprentice rates see "Apprentice- OPERATING ENGINEERS"

OILER (TRUCK CRANES, GRADALLS) OPERATING ENGINEERS LOCAL 4	12/01/2016	\$26.94	\$10.00	\$15.25	\$0.00	\$52.19
	06/01/2017	\$27.54	\$10.00	\$15.25	\$0.00	\$52.79
	12/01/2017	\$28.15	\$10.00	\$15.25	\$0.00	\$53.40

For apprentice rates see "Apprentice- OPERATING ENGINEERS"

OTHER POWER DRIVEN EQUIPMENT - CLASS II OPERATING ENGINEERS LOCAL 4	12/01/2016	\$44.94	\$10.00	\$15.25	\$0.00	\$70.19
	06/01/2017	\$45.93	\$10.00	\$15.25	\$0.00	\$71.18
	12/01/2017	\$46.92	\$10.00	\$15.25	\$0.00	\$72.17

For apprentice rates see "Apprentice- OPERATING ENGINEERS"

PAINTER (BRIDGES/TANKS) PAINTERS LOCAL 35 - ZONE 2	01/01/2017	\$51.41	\$7.85	\$16.10	\$0.00	\$75.36
---	------------	---------	--------	---------	--------	---------

Classification

Effective Date Base Wage Health Pension Supplemental Unemployment Total Rate

Apprentice - PAINTER Local 35 - BRIDGES/TANKS

Effective Date - 01/01/2017

Step	percent	Apprentice Base Wage	Health	Pension	Supplemental Unemployment	Total Rate
1	50	\$25.71	\$7.85	\$0.00	\$0.00	\$33.56
2	55	\$28.28	\$7.85	\$3.66	\$0.00	\$39.79
3	60	\$30.85	\$7.85	\$3.99	\$0.00	\$42.69
4	65	\$33.42	\$7.85	\$4.32	\$0.00	\$45.59
5	70	\$35.99	\$7.85	\$14.11	\$0.00	\$57.95
6	75	\$38.56	\$7.85	\$14.44	\$0.00	\$60.85
7	80	\$41.13	\$7.85	\$14.77	\$0.00	\$63.75
8	90	\$46.27	\$7.85	\$15.44	\$0.00	\$69.56

Notes:

Steps are 750 hrs.

Apprentice to Journeyworker Ratio:1:1

PAINTER (SPRAY OR SANDBLAST, NEW) *	01/01/2017	\$42.31	\$7.85	\$16.10	\$0.00	\$66.26
-------------------------------------	------------	---------	--------	---------	--------	---------

* If 30% or more of surfaces to be painted are new construction, NEW paint rate shall be used. *PAINTERS LOCAL 35 - ZONE 2*

Apprentice - PAINTER Local 35 Zone 2 - Spray/Sandblast - New

Effective Date - 01/01/2017

Step	percent	Apprentice Base Wage	Health	Pension	Supplemental Unemployment	Total Rate
1	50	\$21.16	\$7.85	\$0.00	\$0.00	\$29.01
2	55	\$23.27	\$7.85	\$3.66	\$0.00	\$34.78
3	60	\$25.39	\$7.85	\$3.99	\$0.00	\$37.23
4	65	\$27.50	\$7.85	\$4.32	\$0.00	\$39.67
5	70	\$29.62	\$7.85	\$14.11	\$0.00	\$51.58
6	75	\$31.73	\$7.85	\$14.44	\$0.00	\$54.02
7	80	\$33.85	\$7.85	\$14.77	\$0.00	\$56.47
8	90	\$38.08	\$7.85	\$15.44	\$0.00	\$61.37

Notes:

Steps are 750 hrs.

Apprentice to Journeyworker Ratio:1:1

PAINTER (SPRAY OR SANDBLAST, REPAINT)	01/01/2017	\$40.37	\$7.85	\$16.10	\$0.00	\$64.32
---------------------------------------	------------	---------	--------	---------	--------	---------

PAINTERS LOCAL 35 - ZONE 2

Classification

Effective Date Base Wage Health Pension Supplemental Unemployment Total Rate

Apprentice - PAINTER Local 35 Zone 2 - Spray/Sandblast - Repaint

Effective Date - 01/01/2017

Step	percent	Apprentice Base Wage	Health	Pension	Supplemental Unemployment	Total Rate
1	50	\$20.19	\$7.85	\$0.00	\$0.00	\$28.04
2	55	\$22.20	\$7.85	\$3.66	\$0.00	\$33.71
3	60	\$24.22	\$7.85	\$3.99	\$0.00	\$36.06
4	65	\$26.24	\$7.85	\$4.32	\$0.00	\$38.41
5	70	\$28.26	\$7.85	\$14.11	\$0.00	\$50.22
6	75	\$30.28	\$7.85	\$14.44	\$0.00	\$52.57
7	80	\$32.30	\$7.85	\$14.77	\$0.00	\$54.92
8	90	\$36.33	\$7.85	\$15.44	\$0.00	\$59.62

Notes:

Steps are 750 hrs.

Apprentice to Journeyworker Ratio:1:1

PAINTER (TRAFFIC MARKINGS) LABORERS - ZONE 1	12/01/2016	\$36.35	\$7.60	\$14.15	\$0.00	\$58.10
	06/01/2017	\$37.35	\$7.60	\$14.15	\$0.00	\$59.10
	12/01/2017	\$38.20	\$7.60	\$14.15	\$0.00	\$59.95
	06/01/2018	\$39.15	\$7.60	\$14.15	\$0.00	\$60.90
	12/01/2018	\$40.10	\$7.60	\$14.15	\$0.00	\$61.85
	06/01/2019	\$41.10	\$7.60	\$14.15	\$0.00	\$62.85
	12/01/2019	\$42.10	\$7.60	\$14.15	\$0.00	\$63.85

For Apprentice rates see "Apprentice- LABORER"

PAINTER / TAPER (BRUSH, NEW) *	01/01/2017	\$40.91	\$7.85	\$16.10	\$0.00	\$64.86
--------------------------------	------------	---------	--------	---------	--------	---------

* If 30% or more of surfaces to be painted are new construction, NEW paint rate shall be used. PAINTERS LOCAL 35 - ZONE 2

Apprentice - PAINTER - Local 35 Zone 2 - BRUSH NEW

Effective Date - 01/01/2017

Step	percent	Apprentice Base Wage	Health	Pension	Supplemental Unemployment	Total Rate
1	50	\$20.46	\$7.85	\$0.00	\$0.00	\$28.31
2	55	\$22.50	\$7.85	\$3.66	\$0.00	\$34.01
3	60	\$24.55	\$7.85	\$3.99	\$0.00	\$36.39
4	65	\$26.59	\$7.85	\$4.32	\$0.00	\$38.76
5	70	\$28.64	\$7.85	\$14.11	\$0.00	\$50.60
6	75	\$30.68	\$7.85	\$14.44	\$0.00	\$52.97
7	80	\$32.73	\$7.85	\$14.77	\$0.00	\$55.35
8	90	\$36.82	\$7.85	\$15.44	\$0.00	\$60.11

Notes:

Steps are 750 hrs.

Apprentice to Journeyworker Ratio:1:1

Classification	Effective Date	Base Wage	Health	Pension	Supplemental Unemployment	Total Rate
PAINTER / TAPER (BRUSH, REPAINT) <i>PAINTERS LOCAL 35 - ZONE 2</i>	01/01/2017	\$38.97	\$7.85	\$16.10	\$0.00	\$62.92

Apprentice - PAINTER Local 35 Zone 2 - BRUSH REPAINT

Effective Date - 01/01/2017

Step	percent	Apprentice Base Wage	Health	Pension	Supplemental Unemployment	Total Rate
1	50	\$19.49	\$7.85	\$0.00	\$0.00	\$27.34
2	55	\$21.43	\$7.85	\$3.66	\$0.00	\$32.94
3	60	\$23.38	\$7.85	\$3.99	\$0.00	\$35.22
4	65	\$25.33	\$7.85	\$4.32	\$0.00	\$37.50
5	70	\$27.28	\$7.85	\$14.11	\$0.00	\$49.24
6	75	\$29.23	\$7.85	\$14.44	\$0.00	\$51.52
7	80	\$31.18	\$7.85	\$14.77	\$0.00	\$53.80
8	90	\$35.07	\$7.85	\$15.44	\$0.00	\$58.36

Notes:

Steps are 750 hrs.

Apprentice to Journeyworker Ratio:1:1

PANEL & PICKUP TRUCKS DRIVER <i>TEAMSTERS JOINT COUNCIL NO. 10 ZONE A</i>	12/01/2016	\$33.08	\$10.91	\$10.89	\$0.00	\$54.88
--	------------	---------	---------	---------	--------	---------

PIER AND DOCK CONSTRUCTOR (UNDERPINNING AND DECK) <i>PILE DRIVER LOCAL 56 (ZONE 1)</i> For apprentice rates see "Apprentice- PILE DRIVER"	08/01/2015	\$42.04	\$9.80	\$19.23	\$0.00	\$71.07
---	------------	---------	--------	---------	--------	---------

PILE DRIVER <i>PILE DRIVER LOCAL 56 (ZONE 1)</i>	08/01/2015	\$42.04	\$9.80	\$19.23	\$0.00	\$71.07
---	------------	---------	--------	---------	--------	---------

Apprentice - PILE DRIVER - Local 56 Zone 1

Effective Date - 08/01/2015

Step	percent	Apprentice Base Wage	Health	Pension	Supplemental Unemployment	Total Rate
1	50	\$21.02	\$9.80	\$19.23	\$0.00	\$50.05
2	60	\$25.22	\$9.80	\$19.23	\$0.00	\$54.25
3	70	\$29.43	\$9.80	\$19.23	\$0.00	\$58.46
4	75	\$31.53	\$9.80	\$19.23	\$0.00	\$60.56
5	80	\$33.63	\$9.80	\$19.23	\$0.00	\$62.66
6	80	\$33.63	\$9.80	\$19.23	\$0.00	\$62.66
7	90	\$37.84	\$9.80	\$19.23	\$0.00	\$66.87
8	90	\$37.84	\$9.80	\$19.23	\$0.00	\$66.87

Notes:

Apprentice to Journeyworker Ratio:1:3

PIPEFITTER & STEAMFITTER <i>PIPEFITTERS LOCAL 537</i>	03/01/2017	\$51.19	\$9.70	\$18.14	\$0.00	\$79.03
--	------------	---------	--------	---------	--------	---------

Apprentice - PIPEFITTER - Local 537

Effective Date - 03/01/2017

Step	percent	Apprentice Base Wage	Health	Pension	Supplemental Unemployment	Total Rate
1	40	\$20.48	\$9.70	\$7.50	\$0.00	\$37.68
2	45	\$23.04	\$9.70	\$18.14	\$0.00	\$50.88
3	60	\$30.71	\$9.70	\$18.14	\$0.00	\$58.55
4	70	\$35.83	\$9.70	\$18.14	\$0.00	\$63.67
5	80	\$40.95	\$9.70	\$18.14	\$0.00	\$68.79

Notes:
 ** 1:3; 3:15; 1:10 thereafter / Steps are 1 yr.
 Refrig/AC Mechanic **1:1;1:2;2:4;3:6;4:8;5:10;6:12;7:14;8:17;9:20;10:23(Max)

Apprentice to Journeyworker Ratio:**

PIPELAYER	12/01/2016	\$36.60	\$7.60	\$14.15	\$0.00	\$58.35
LABORERS - ZONE 1	06/01/2017	\$37.60	\$7.60	\$14.15	\$0.00	\$59.35
	12/01/2017	\$38.45	\$7.60	\$14.15	\$0.00	\$60.20
	06/01/2018	\$39.40	\$7.60	\$14.15	\$0.00	\$61.15
	12/01/2018	\$40.35	\$7.60	\$14.15	\$0.00	\$62.10
	06/01/2019	\$41.35	\$7.60	\$14.15	\$0.00	\$63.10
	12/01/2019	\$42.35	\$7.60	\$14.15	\$0.00	\$64.10

For apprentice rates see "Apprentice- LABORER"

PLUMBERS & GASFITTERS	03/01/2017	\$52.69	\$11.32	\$15.46	\$0.00	\$79.47
PLUMBERS & GASFITTERS LOCAL 12						

Apprentice - PLUMBER/GASFITTER - Local 12

Effective Date - 03/01/2017

Step	percent	Apprentice Base Wage	Health	Pension	Supplemental Unemployment	Total Rate
1	35	\$18.44	\$11.32	\$5.74	\$0.00	\$35.50
2	40	\$21.08	\$11.32	\$6.49	\$0.00	\$38.89
3	55	\$28.98	\$11.32	\$8.73	\$0.00	\$49.03
4	65	\$34.25	\$11.32	\$10.23	\$0.00	\$55.80
5	75	\$39.52	\$11.32	\$11.72	\$0.00	\$62.56

Notes:
 ** 1:2; 2:6; 3:10; 4:14; 5:19/Steps are 1 yr
 Step4 with lic\$58.50 Step5 with lic\$65.36

Apprentice to Journeyworker Ratio:**

PNEUMATIC CONTROLS (TEMP.)	03/01/2017	\$51.19	\$9.70	\$18.14	\$0.00	\$79.03
PIPEFITTERS LOCAL 537						

For apprentice rates see "Apprentice- PIPEFITTER" or "PLUMBER/PIPEFITTER"

Classification	Effective Date	Base Wage	Health	Pension	Supplemental Unemployment	Total Rate
PNEUMATIC DRILL/TOOL OPERATOR <i>LABORERS - ZONE 1</i>	12/01/2016	\$36.60	\$7.60	\$14.15	\$0.00	\$58.35
	06/01/2017	\$37.60	\$7.60	\$14.15	\$0.00	\$59.35
	12/01/2017	\$38.45	\$7.60	\$14.15	\$0.00	\$60.20
	06/01/2018	\$39.40	\$7.60	\$14.15	\$0.00	\$61.15
	12/01/2018	\$40.35	\$7.60	\$14.15	\$0.00	\$62.10
	06/01/2019	\$41.35	\$7.60	\$14.15	\$0.00	\$63.10
	12/01/2019	\$42.35	\$7.60	\$14.15	\$0.00	\$64.10
For apprentice rates see "Apprentice- LABORER"						
POWDERMAN & BLASTER <i>LABORERS - ZONE 1</i>	12/01/2016	\$37.35	\$7.60	\$14.15	\$0.00	\$59.10
	06/01/2017	\$38.35	\$7.60	\$14.15	\$0.00	\$60.10
	12/01/2017	\$39.20	\$7.60	\$14.15	\$0.00	\$60.95
	06/01/2018	\$40.15	\$7.60	\$14.15	\$0.00	\$61.90
	12/01/2018	\$41.10	\$7.60	\$14.15	\$0.00	\$62.85
	06/01/2019	\$42.10	\$7.60	\$14.15	\$0.00	\$63.85
	12/01/2019	\$43.10	\$7.60	\$14.15	\$0.00	\$64.85
For apprentice rates see "Apprentice- LABORER"						
POWER SHOVEL/DERRICK/TRENCHING MACHINE <i>OPERATING ENGINEERS LOCAL 4</i>	12/01/2016	\$45.38	\$10.00	\$15.25	\$0.00	\$70.63
	06/01/2017	\$46.38	\$10.00	\$15.25	\$0.00	\$71.63
	12/01/2017	\$47.38	\$10.00	\$15.25	\$0.00	\$72.63
For apprentice rates see "Apprentice- OPERATING ENGINEERS"						
PUMP OPERATOR (CONCRETE) <i>OPERATING ENGINEERS LOCAL 4</i>	12/01/2016	\$45.38	\$10.00	\$15.25	\$0.00	\$70.63
	06/01/2017	\$46.38	\$10.00	\$15.25	\$0.00	\$71.63
	12/01/2017	\$47.38	\$10.00	\$15.25	\$0.00	\$72.63
For apprentice rates see "Apprentice- OPERATING ENGINEERS"						
PUMP OPERATOR (DEWATERING, OTHER) <i>OPERATING ENGINEERS LOCAL 4</i>	12/01/2016	\$31.17	\$10.00	\$15.25	\$0.00	\$56.42
	06/01/2017	\$31.86	\$10.00	\$15.25	\$0.00	\$57.11
	12/01/2017	\$32.55	\$10.00	\$15.25	\$0.00	\$57.80
For apprentice rates see "Apprentice- OPERATING ENGINEERS"						
READY MIX CONCRETE DRIVERS after 4/30/10 (Drivers Hired After 4/30/2010) <i>TEAMSTERS LOCAL 25c</i>	05/01/2017	\$28.18	\$8.23	\$9.72	\$0.00	\$46.13
	07/01/2017	\$28.18	\$8.48	\$9.72	\$0.00	\$46.38
READY-MIX CONCRETE DRIVER <i>TEAMSTERS LOCAL 25c</i>	05/01/2017	\$29.48	\$8.23	\$9.72	\$0.00	\$47.43
	07/01/2017	\$29.48	\$8.48	\$9.72	\$0.00	\$47.68
RECLAIMERS <i>OPERATING ENGINEERS LOCAL 4</i>	12/01/2016	\$44.94	\$10.00	\$15.25	\$0.00	\$70.19
	06/01/2017	\$45.93	\$10.00	\$15.25	\$0.00	\$71.18
	12/01/2017	\$46.92	\$10.00	\$15.25	\$0.00	\$72.17
For apprentice rates see "Apprentice- OPERATING ENGINEERS"						
RESIDENTIAL WOOD FRAME (All Other Work) <i>CARPENTERS -ZONE 2 (Residential Wood)</i>	06/01/2016	\$25.32	\$9.80	\$16.82	\$0.00	\$51.94
RESIDENTIAL WOOD FRAME CARPENTER ** ** The Residential Wood Frame Carpenter classification applies only to the construction of new, wood frame residences that do not exceed four stories including the basement. <i>CARPENTERS -ZONE 2 (Residential Wood)</i>	04/01/2017	\$26.31	\$7.07	\$7.18	\$0.00	\$40.56
	10/01/2017	\$26.93	\$7.07	\$7.18	\$0.00	\$41.18
	04/01/2018	\$27.35	\$7.07	\$7.18	\$0.00	\$41.60
	10/01/2018	\$27.77	\$7.07	\$7.18	\$0.00	\$42.02
	04/01/2019	\$28.20	\$7.07	\$7.18	\$0.00	\$42.45
	10/01/2019	\$28.63	\$7.07	\$7.18	\$0.00	\$42.88
As of 9/1/09 Carpentry work on wood-frame residential WEATHERIZATION projects shall be paid the RESIDENTIAL WOOD FRAME CARPENTER rate.						

Classification

Effective Date Base Wage Health Pension Supplemental Unemployment Total Rate

Apprentice - CARPENTER (Residential Wood Frame) - Zone 2

Effective Date - 04/01/2017

Step	percent	Apprentice Base Wage	Health	Pension	Supplemental Unemployment	Total Rate
1	60	\$15.79	\$7.07	\$0.00	\$0.00	\$22.86
2	60	\$15.79	\$7.07	\$0.00	\$0.00	\$22.86
3	65	\$17.10	\$7.07	\$7.18	\$0.00	\$31.35
4	70	\$18.42	\$7.07	\$7.18	\$0.00	\$32.67
5	75	\$19.73	\$7.07	\$7.18	\$0.00	\$33.98
6	80	\$21.05	\$7.07	\$7.18	\$0.00	\$35.30
7	85	\$22.36	\$7.07	\$7.18	\$0.00	\$36.61
8	90	\$23.68	\$7.07	\$7.18	\$0.00	\$37.93

Effective Date - 10/01/2017

Step	percent	Apprentice Base Wage	Health	Pension	Supplemental Unemployment	Total Rate
1	60	\$16.16	\$7.07	\$0.00	\$0.00	\$23.23
2	60	\$16.16	\$7.07	\$0.00	\$0.00	\$23.23
3	65	\$17.50	\$7.07	\$7.18	\$0.00	\$31.75
4	70	\$18.85	\$7.07	\$7.18	\$0.00	\$33.10
5	75	\$20.20	\$7.07	\$7.18	\$0.00	\$34.45
6	80	\$21.54	\$7.07	\$7.18	\$0.00	\$35.79
7	85	\$22.89	\$7.07	\$7.18	\$0.00	\$37.14
8	90	\$24.24	\$7.07	\$7.18	\$0.00	\$38.49

Notes:

Apprentice to Journeyworker Ratio:1:5

RIDE-ON MOTORIZED BUGGY OPERATOR <i>LABORERS - ZONE 1</i>	12/01/2016	\$36.60	\$7.60	\$14.15	\$0.00	\$58.35
	06/01/2017	\$37.60	\$7.60	\$14.15	\$0.00	\$59.35
	12/01/2017	\$38.45	\$7.60	\$14.15	\$0.00	\$60.20
	06/01/2018	\$39.40	\$7.60	\$14.15	\$0.00	\$61.15
	12/01/2018	\$40.35	\$7.60	\$14.15	\$0.00	\$62.10
	06/01/2019	\$41.35	\$7.60	\$14.15	\$0.00	\$63.10
	12/01/2019	\$42.35	\$7.60	\$14.15	\$0.00	\$64.10

For apprentice rates see "Apprentice- LABORER"

ROLLER/SPREADER/MULCHING MACHINE <i>OPERATING ENGINEERS LOCAL 4</i>	12/01/2016	\$44.94	\$10.00	\$15.25	\$0.00	\$70.19
	06/01/2017	\$45.93	\$10.00	\$15.25	\$0.00	\$71.18
	12/01/2017	\$46.92	\$10.00	\$15.25	\$0.00	\$72.17

For apprentice rates see "Apprentice- OPERATING ENGINEERS"

ROOFER (Inc.Roofing Waterproofing &Roofing Damproofg) <i>ROOFERS LOCAL 33</i>	02/01/2017	\$41.36	\$11.10	\$13.80	\$0.00	\$66.26
	08/01/2017	\$42.46	\$11.10	\$13.80	\$0.00	\$67.36
	02/01/2018	\$43.61	\$11.10	\$13.80	\$0.00	\$68.51
	08/01/2018	\$44.71	\$11.10	\$13.80	\$0.00	\$69.61
	02/01/2019	\$45.86	\$11.10	\$13.80	\$0.00	\$70.76

Classification

Effective Date Base Wage Health Pension Supplemental Unemployment Total Rate

Apprentice - ROOFER - Local 33

Effective Date - 02/01/2017

Step	percent	Apprentice Base Wage	Health	Pension	Supplemental Unemployment	Total Rate
1	50	\$20.68	\$11.10	\$3.44	\$0.00	\$35.22
2	60	\$24.82	\$11.10	\$13.80	\$0.00	\$49.72
3	65	\$26.88	\$11.10	\$13.80	\$0.00	\$51.78
4	75	\$31.02	\$11.10	\$13.80	\$0.00	\$55.92
5	85	\$35.16	\$11.10	\$13.80	\$0.00	\$60.06

Effective Date - 08/01/2017

Step	percent	Apprentice Base Wage	Health	Pension	Supplemental Unemployment	Total Rate
1	50	\$21.23	\$11.10	\$3.44	\$0.00	\$35.77
2	60	\$25.48	\$11.10	\$13.80	\$0.00	\$50.38
3	65	\$27.60	\$11.10	\$13.80	\$0.00	\$52.50
4	75	\$31.85	\$11.10	\$13.80	\$0.00	\$56.75
5	85	\$36.09	\$11.10	\$13.80	\$0.00	\$60.99

Notes: ** 1:5, 2:6-10, the 1:10; Reroofing: 1:4, then 1:1
 Step 1 is 2000 hrs.; Steps 2-5 are 1000 hrs.
 (Hot Pitch Mechanics' receive \$1.00 hr. above ROOFER)

Apprentice to Journeyworker Ratio:**

ROOFER SLATE / TILE / PRECAST CONCRETE	02/01/2017	\$41.61	\$11.10	\$13.80	\$0.00	\$66.51
ROOFERS LOCAL 33	08/01/2017	\$42.71	\$11.10	\$13.80	\$0.00	\$67.61
	02/01/2018	\$43.86	\$11.10	\$13.80	\$0.00	\$68.76
	08/01/2018	\$44.96	\$11.10	\$13.80	\$0.00	\$69.86
	02/01/2019	\$46.11	\$11.10	\$13.80	\$0.00	\$71.01
For apprentice rates see "Apprentice- ROOFER"						
SHEETMETAL WORKER	02/01/2017	\$43.72	\$11.45	\$23.07	\$2.35	\$80.59
SHEETMETAL WORKERS LOCAL 17 - A	08/01/2017	\$44.82	\$11.45	\$23.07	\$2.35	\$81.69
	02/01/2018	\$45.97	\$11.45	\$23.07	\$2.35	\$82.84

Classification

Effective Date Base Wage Health Pension Supplemental Unemployment Total Rate

Apprentice - SHEET METAL WORKER - Local 17-A

Effective Date - 02/01/2017

Step	percent	Apprentice Base Wage	Health	Pension	Supplemental Unemployment	Total Rate
1	40	\$17.49	\$11.45	\$5.24	\$0.00	\$34.18
2	40	\$17.49	\$11.45	\$5.24	\$0.00	\$34.18
3	45	\$19.67	\$11.45	\$10.31	\$1.24	\$42.67
4	45	\$19.67	\$11.45	\$10.31	\$1.24	\$42.67
5	50	\$21.86	\$11.45	\$11.21	\$1.34	\$45.86
6	50	\$21.86	\$11.45	\$11.46	\$1.34	\$46.11
7	60	\$26.23	\$11.45	\$13.02	\$1.52	\$52.22
8	65	\$28.42	\$11.45	\$13.93	\$1.61	\$55.41
9	75	\$32.79	\$11.45	\$15.74	\$1.80	\$61.78
10	85	\$37.16	\$11.45	\$17.05	\$1.97	\$67.63

Effective Date - 08/01/2017

Step	percent	Apprentice Base Wage	Health	Pension	Supplemental Unemployment	Total Rate
1	40	\$17.93	\$11.45	\$5.24	\$0.00	\$34.62
2	40	\$17.93	\$11.45	\$5.24	\$0.00	\$34.62
3	45	\$20.17	\$11.45	\$10.31	\$1.26	\$43.19
4	45	\$20.17	\$11.45	\$10.31	\$1.26	\$43.19
5	50	\$22.41	\$11.45	\$11.21	\$1.35	\$46.42
6	50	\$22.41	\$11.45	\$11.46	\$1.36	\$46.68
7	60	\$26.89	\$11.45	\$13.02	\$1.54	\$52.90
8	65	\$29.13	\$11.45	\$13.93	\$1.64	\$56.15
9	75	\$33.62	\$11.45	\$15.74	\$1.82	\$62.63
10	85	\$38.10	\$11.45	\$17.05	\$2.00	\$68.60

Notes:
Steps are 6 mos.

Apprentice to Journeyworker Ratio:1:4

SIGN ERECTOR PAINTERS LOCAL 35 - ZONE 2	06/01/2013	\$25.81	\$7.07	\$7.05	\$0.00	\$39.93
--	------------	---------	--------	--------	--------	---------

Classification

Effective Date Base Wage Health Pension Supplemental Unemployment Total Rate

Apprentice - SIGN ERECTOR - Local 35 Zone 2

Effective Date - 06/01/2013

Step	percent	Apprentice Base Wage	Health	Pension	Supplemental Unemployment	Total Rate
1	50	\$12.91	\$7.07	\$0.00	\$0.00	\$19.98
2	55	\$14.20	\$7.07	\$2.45	\$0.00	\$23.72
3	60	\$15.49	\$7.07	\$2.45	\$0.00	\$25.01
4	65	\$16.78	\$7.07	\$2.45	\$0.00	\$26.30
5	70	\$18.07	\$7.07	\$7.05	\$0.00	\$32.19
6	75	\$19.36	\$7.07	\$7.05	\$0.00	\$33.48
7	80	\$20.65	\$7.07	\$7.05	\$0.00	\$34.77
8	85	\$21.94	\$7.07	\$7.05	\$0.00	\$36.06
9	90	\$23.23	\$7.07	\$7.05	\$0.00	\$37.35

Notes:
Steps are 4 mos.

Apprentice to Journeyworker Ratio:1:1

SPECIALIZED EARTH MOVING EQUIP < 35 TONS <i>TEAMSTERS JOINT COUNCIL NO. 10 ZONE A</i>	12/01/2016	\$33.54	\$10.91	\$10.89	\$0.00	\$55.34
SPECIALIZED EARTH MOVING EQUIP > 35 TONS <i>TEAMSTERS JOINT COUNCIL NO. 10 ZONE A</i>	12/01/2016	\$33.83	\$10.91	\$10.89	\$0.00	\$55.63
SPRINKLER FITTER <i>SPRINKLER FITTERS LOCAL 550 - (Section A) Zone 1</i>	03/01/2017	\$56.08	\$8.77	\$17.20	\$0.00	\$82.05

Apprentice - SPRINKLER FITTER - Local 550 (Section A) Zone 1

Effective Date - 03/01/2017

Step	percent	Apprentice Base Wage	Health	Pension	Supplemental Unemployment	Total Rate
1	35	\$19.63	\$8.52	\$8.70	\$0.00	\$36.85
2	40	\$22.43	\$8.52	\$8.70	\$0.00	\$39.65
3	45	\$25.24	\$8.52	\$8.70	\$0.00	\$42.46
4	50	\$28.04	\$8.52	\$8.70	\$0.00	\$45.26
5	55	\$30.84	\$8.52	\$8.70	\$0.00	\$48.06
6	60	\$33.65	\$8.52	\$10.20	\$0.00	\$52.37
7	65	\$36.45	\$8.52	\$10.20	\$0.00	\$55.17
8	70	\$39.26	\$8.52	\$10.20	\$0.00	\$57.98
9	75	\$42.06	\$8.52	\$10.20	\$0.00	\$60.78
10	80	\$44.86	\$8.52	\$10.20	\$0.00	\$63.58

Notes: Apprentice entered prior 9/30/10:
40/45/50/55/60/65/70/75/80/85
Steps are 850 hours

Apprentice to Journeyworker Ratio:1:3

STEAM BOILER OPERATOR <i>OPERATING ENGINEERS LOCAL 4</i>	12/01/2016	\$44.94	\$10.00	\$15.25	\$0.00	\$70.19
	06/01/2017	\$45.93	\$10.00	\$15.25	\$0.00	\$71.18
	12/01/2017	\$46.92	\$10.00	\$15.25	\$0.00	\$72.17

Classification	Effective Date	Base Wage	Health	Pension	Supplemental Unemployment	Total Rate
For apprentice rates see "Apprentice- OPERATING ENGINEERS"						
TAMPERS, SELF-PROPELLED OR TRACTOR DRAWN OPERATING ENGINEERS LOCAL 4	12/01/2016	\$44.94	\$10.00	\$15.25	\$0.00	\$70.19
	06/01/2017	\$45.93	\$10.00	\$15.25	\$0.00	\$71.18
	12/01/2017	\$46.92	\$10.00	\$15.25	\$0.00	\$72.17
For apprentice rates see "Apprentice- OPERATING ENGINEERS"						
TELECOMMUNICATION TECHNICIAN ELECTRICIANS LOCAL 103	03/01/2017	\$36.25	\$13.00	\$15.60	\$0.00	\$64.85
	09/01/2017	\$36.96	\$13.00	\$15.62	\$0.00	\$65.58
	03/01/2018	\$37.86	\$13.00	\$15.65	\$0.00	\$66.51
	09/01/2018	\$38.75	\$13.00	\$15.67	\$0.00	\$67.42
	03/01/2019	\$39.65	\$13.00	\$15.70	\$0.00	\$68.35

Apprentice - TELECOMMUNICATION TECHNICIAN - Local 103

Effective Date - 03/01/2017

Step	percent	Apprentice Base Wage	Health	Pension	Supplemental Unemployment	Total Rate
1	40	\$14.50	\$13.00	\$0.44	\$0.00	\$27.94
2	40	\$14.50	\$13.00	\$0.44	\$0.00	\$27.94
3	45	\$16.31	\$13.00	\$12.54	\$0.00	\$41.85
4	45	\$16.31	\$13.00	\$12.54	\$0.00	\$41.85
5	50	\$18.13	\$13.00	\$12.81	\$0.00	\$43.94
6	55	\$19.94	\$13.00	\$13.09	\$0.00	\$46.03
7	60	\$21.75	\$13.00	\$13.37	\$0.00	\$48.12
8	65	\$23.56	\$13.00	\$13.65	\$0.00	\$50.21
9	70	\$25.38	\$13.00	\$13.93	\$0.00	\$52.31
10	75	\$27.19	\$13.00	\$14.21	\$0.00	\$54.40

Effective Date - 09/01/2017

Step	percent	Apprentice Base Wage	Health	Pension	Supplemental Unemployment	Total Rate
1	40	\$14.78	\$13.00	\$0.44	\$0.00	\$28.22
2	40	\$14.78	\$13.00	\$0.44	\$0.00	\$28.22
3	45	\$16.63	\$13.00	\$12.55	\$0.00	\$42.18
4	45	\$16.63	\$13.00	\$12.55	\$0.00	\$42.18
5	50	\$18.48	\$13.00	\$12.82	\$0.00	\$44.30
6	55	\$20.33	\$13.00	\$13.10	\$0.00	\$46.43
7	60	\$22.18	\$13.00	\$13.39	\$0.00	\$48.57
8	65	\$24.02	\$13.00	\$13.66	\$0.00	\$50.68
9	70	\$25.87	\$13.00	\$13.95	\$0.00	\$52.82
10	75	\$27.72	\$13.00	\$14.22	\$0.00	\$54.94

Notes:

Apprentice to Journeyworker Ratio:1:1

TERRAZZO FINISHERS BRICKLAYERS LOCAL 3 - MARBLE & TILE	02/01/2017	\$49.70	\$10.75	\$19.22	\$0.00	\$79.67
---	------------	---------	---------	---------	--------	---------

Apprentice - TERRAZZO FINISHER - Local 3 Marble & Tile

Effective Date - 02/01/2017

Step	percent	Apprentice Base Wage	Health	Pension	Supplemental Unemployment	Total Rate
1	50	\$24.85	\$10.75	\$19.22	\$0.00	\$54.82
2	60	\$29.82	\$10.75	\$19.22	\$0.00	\$59.79
3	70	\$34.79	\$10.75	\$19.22	\$0.00	\$64.76
4	80	\$39.76	\$10.75	\$19.22	\$0.00	\$69.73
5	90	\$44.73	\$10.75	\$19.22	\$0.00	\$74.70

Notes:

Apprentice to Journeyworker Ratio:1:3

TEST BORING DRILLER <i>LABORERS - FOUNDATION AND MARINE</i>	12/01/2016	\$37.70	\$7.60	\$14.35	\$0.00	\$59.65
--	------------	---------	--------	---------	--------	---------

For apprentice rates see "Apprentice- LABORER"

TEST BORING DRILLER HELPER <i>LABORERS - FOUNDATION AND MARINE</i>	12/01/2016	\$36.42	\$7.60	\$14.35	\$0.00	\$58.37
---	------------	---------	--------	---------	--------	---------

For apprentice rates see "Apprentice- LABORER"

TEST BORING LABORER <i>LABORERS - FOUNDATION AND MARINE</i>	12/01/2016	\$36.30	\$7.60	\$14.35	\$0.00	\$58.25
--	------------	---------	--------	---------	--------	---------

For apprentice rates see "Apprentice- LABORER"

TRACTORS/PORTABLE STEAM GENERATORS <i>OPERATING ENGINEERS LOCAL 4</i>	12/01/2016	\$44.94	\$10.00	\$15.25	\$0.00	\$70.19
	06/01/2017	\$45.93	\$10.00	\$15.25	\$0.00	\$71.18
	12/01/2017	\$46.92	\$10.00	\$15.25	\$0.00	\$72.17

For apprentice rates see "Apprentice- OPERATING ENGINEERS"

TRAILERS FOR EARTH MOVING EQUIPMENT <i>TEAMSTERS JOINT COUNCIL NO. 10 ZONE A</i>	12/01/2016	\$34.12	\$10.91	\$10.89	\$0.00	\$55.92
---	------------	---------	---------	---------	--------	---------

TUNNEL WORK - COMPRESSED AIR <i>LABORERS (COMPRESSED AIR)</i>	12/01/2016	\$48.58	\$7.60	\$14.75	\$0.00	\$70.93
--	------------	---------	--------	---------	--------	---------

For apprentice rates see "Apprentice- LABORER"

TUNNEL WORK - COMPRESSED AIR (HAZ. WASTE) <i>LABORERS (COMPRESSED AIR)</i>	12/01/2016	\$50.58	\$7.60	\$14.75	\$0.00	\$72.93
---	------------	---------	--------	---------	--------	---------

For apprentice rates see "Apprentice- LABORER"

TUNNEL WORK - FREE AIR <i>LABORERS (FREE AIR TUNNEL)</i>	12/01/2016	\$40.65	\$7.60	\$14.75	\$0.00	\$63.00
---	------------	---------	--------	---------	--------	---------

For apprentice rates see "Apprentice- LABORER"

TUNNEL WORK - FREE AIR (HAZ. WASTE) <i>LABORERS (FREE AIR TUNNEL)</i>	12/01/2016	\$42.65	\$7.60	\$14.75	\$0.00	\$65.00
--	------------	---------	--------	---------	--------	---------

For apprentice rates see "Apprentice- LABORER"

VAC-HAUL <i>TEAMSTERS JOINT COUNCIL NO. 10 ZONE A</i>	12/01/2016	\$33.54	\$10.91	\$10.89	\$0.00	\$55.34
--	------------	---------	---------	---------	--------	---------

Classification	Effective Date	Base Wage	Health	Pension	Supplemental Unemployment	Total Rate
WAGON DRILL OPERATOR <i>LABORERS - ZONE 1</i>	12/01/2016	\$36.60	\$7.60	\$14.15	\$0.00	\$58.35
	06/01/2017	\$37.60	\$7.60	\$14.15	\$0.00	\$59.35
	12/01/2017	\$38.45	\$7.60	\$14.15	\$0.00	\$60.20
	06/01/2018	\$39.40	\$7.60	\$14.15	\$0.00	\$61.15
	12/01/2018	\$40.35	\$7.60	\$14.15	\$0.00	\$62.10
	06/01/2019	\$41.35	\$7.60	\$14.15	\$0.00	\$63.10
	12/01/2019	\$42.35	\$7.60	\$14.15	\$0.00	\$64.10
For apprentice rates see "Apprentice- LABORER"						
WASTE WATER PUMP OPERATOR <i>OPERATING ENGINEERS LOCAL 4</i>	12/01/2016	\$45.38	\$10.00	\$15.25	\$0.00	\$70.63
	06/01/2017	\$46.38	\$10.00	\$15.25	\$0.00	\$71.63
	12/01/2017	\$47.38	\$10.00	\$15.25	\$0.00	\$72.63
For apprentice rates see "Apprentice- OPERATING ENGINEERS"						
WATER METER INSTALLER <i>PLUMBERS & GASFITTERS LOCAL 12</i>	03/01/2017	\$52.69	\$11.32	\$15.46	\$0.00	\$79.47
For apprentice rates see "Apprentice- PLUMBER/PIPEFITTER" or "PLUMBER/GASFITTER"						
Outside Electrical - East						
CABLE TECHNICIAN (Power Zone) <i>OUTSIDE ELECTRICAL WORKERS - EAST LOCAL 104</i>	08/28/2016	\$26.61	\$7.50	\$1.80	\$0.00	\$35.91
	09/03/2017	\$27.14	\$7.75	\$1.81	\$0.00	\$36.70
For apprentice rates see "Apprentice- LINEMAN"						
CABLEMAN (Underground Ducts & Cables) <i>OUTSIDE ELECTRICAL WORKERS - EAST LOCAL 104</i>	08/28/2016	\$37.70	\$7.50	\$8.87	\$0.00	\$54.07
	09/03/2017	\$38.45	\$7.75	\$9.53	\$0.00	\$55.73
For apprentice rates see "Apprentice- LINEMAN"						
DRIVER / GROUNDMAN CDL <i>OUTSIDE ELECTRICAL WORKERS - EAST LOCAL 104</i>	08/28/2016	\$31.05	\$7.50	\$8.89	\$0.00	\$47.44
	09/03/2017	\$31.66	\$7.75	\$9.44	\$0.00	\$48.85
For apprentice rates see "Apprentice- LINEMAN"						
DRIVER / GROUNDMAN -Inexperienced (<2000 Hrs) <i>OUTSIDE ELECTRICAL WORKERS - EAST LOCAL 104</i>	08/28/2016	\$24.39	\$7.50	\$1.73	\$0.00	\$33.62
	09/03/2017	\$24.88	\$7.75	\$1.75	\$0.00	\$34.38
For apprentice rates see "Apprentice- LINEMAN"						
EQUIPMENT OPERATOR (Class A CDL) <i>OUTSIDE ELECTRICAL WORKERS - EAST LOCAL 104</i>	08/28/2016	\$37.70	\$7.50	\$12.95	\$0.00	\$58.15
	09/03/2017	\$38.45	\$7.75	\$13.61	\$0.00	\$59.81
For apprentice rates see "Apprentice- LINEMAN"						
EQUIPMENT OPERATOR (Class B CDL) <i>OUTSIDE ELECTRICAL WORKERS - EAST LOCAL 104</i>	08/28/2016	\$33.26	\$7.50	\$9.63	\$0.00	\$50.39
	09/03/2017	\$33.92	\$7.75	\$10.21	\$0.00	\$51.88
For apprentice rates see "Apprentice- LINEMAN"						
GROUNDMAN <i>OUTSIDE ELECTRICAL WORKERS - EAST LOCAL 104</i>	08/28/2016	\$24.39	\$7.50	\$1.73	\$0.00	\$33.62
	09/03/2017	\$24.88	\$7.75	\$1.75	\$0.00	\$34.38
For apprentice rates see "Apprentice- LINEMAN"						
GROUNDMAN -Inexperienced (<2000 Hrs.) <i>OUTSIDE ELECTRICAL WORKERS - EAST LOCAL 104</i>	08/28/2016	\$19.96	\$7.50	\$1.60	\$0.00	\$29.06
	09/03/2017	\$20.35	\$7.75	\$1.61	\$0.00	\$29.71
For apprentice rates see "Apprentice- LINEMAN"						
JOURNEYMAN LINEMAN <i>OUTSIDE ELECTRICAL WORKERS - EAST LOCAL 104</i>	08/28/2016	\$44.35	\$7.50	\$15.83	\$0.00	\$67.68
	09/03/2017	\$45.23	\$7.75	\$16.61	\$0.00	\$69.59

Apprentice - LINEMAN (Outside Electrical) - East Local 104

Effective Date - 08/28/2016

Step	percent	Apprentice Base Wage	Health	Pension	Supplemental Unemployment	Total Rate
1	60	\$26.61	\$7.50	\$3.30	\$0.00	\$37.41
2	65	\$28.83	\$7.50	\$3.36	\$0.00	\$39.69
3	70	\$31.05	\$7.50	\$3.43	\$0.00	\$41.98
4	75	\$33.26	\$7.50	\$5.00	\$0.00	\$45.76
5	80	\$35.48	\$7.50	\$5.06	\$0.00	\$48.04
6	85	\$37.70	\$7.50	\$5.13	\$0.00	\$50.33
7	90	\$39.92	\$7.50	\$7.20	\$0.00	\$54.62

Effective Date - 09/03/2017

Step	percent	Apprentice Base Wage	Health	Pension	Supplemental Unemployment	Total Rate
1	60	\$27.14	\$7.75	\$3.31	\$0.00	\$38.20
2	65	\$29.40	\$7.75	\$3.38	\$0.00	\$40.53
3	70	\$31.66	\$7.75	\$3.45	\$0.00	\$42.86
4	75	\$33.92	\$7.75	\$5.02	\$0.00	\$46.69
5	80	\$36.18	\$7.75	\$5.09	\$0.00	\$49.02
6	85	\$38.45	\$7.75	\$5.15	\$0.00	\$51.35
7	90	\$40.71	\$7.75	\$7.22	\$0.00	\$55.68

Notes:

Apprentice to Journeyworker Ratio:1:2

TELEDATA CABLE SPLICER <i>OUTSIDE ELECTRICAL WORKERS - EAST LOCAL 104</i>	01/01/2016	\$28.98	\$4.25	\$3.12	\$0.00	\$36.35
--	------------	---------	--------	--------	--------	---------

TELEDATA LINEMAN/EQUIPMENT OPERATOR <i>OUTSIDE ELECTRICAL WORKERS - EAST LOCAL 104</i>	01/01/2016	\$27.31	\$4.25	\$3.07	\$0.00	\$34.63
---	------------	---------	--------	--------	--------	---------

TELEDATA WIREMAN/INSTALLER/TECHNICIAN <i>OUTSIDE ELECTRICAL WORKERS - EAST LOCAL 104</i>	01/01/2016	\$27.31	\$4.25	\$3.07	\$0.00	\$34.63
---	------------	---------	--------	--------	--------	---------

TREE TRIMMER <i>OUTSIDE ELECTRICAL WORKERS - EAST LOCAL 104</i>	01/31/2016	\$18.51	\$3.55	\$0.00	\$0.00	\$22.06
--	------------	---------	--------	--------	--------	---------

This classification applies only to tree work done: (a) for a utility company, R.E.A. cooperative, or railroad or coal mining company, and (b) for the purpose of operating, maintaining, or repairing the utility company's equipment, and (c) by a person who is using hand or mechanical cutting methods and is not on the ground. This classification does not apply to wholesale tree removal.

TREE TRIMMER GROUNDMAN <i>OUTSIDE ELECTRICAL WORKERS - EAST LOCAL 104</i>	01/31/2016	\$16.32	\$3.55	\$0.00	\$0.00	\$19.87
--	------------	---------	--------	--------	--------	---------

This classification applies only to tree work done: (a) for a utility company, R.E.A. cooperative, or railroad or coal mining company, and (b) for the purpose of operating, maintaining, or repairing the utility company's equipment, and (c) by a person who is using hand or mechanical cutting methods and is on the ground. This classification does not apply to wholesale tree removal.

Rental of Equipment - East

(2 AXLE) DRIVER - EQUIPMENT <i>TEAMSTERS JOINT COUNCIL NO. 10 ZONE A</i>	12/01/2016	\$33.25	\$10.91	\$0.00	\$0.00	\$44.16
---	------------	---------	---------	--------	--------	---------

(3 AXLE) DRIVER - EQUIPMENT <i>TEAMSTERS JOINT COUNCIL NO. 10 ZONE A</i>	12/01/2016	\$33.32	\$10.91	\$0.00	\$0.00	\$44.23
---	------------	---------	---------	--------	--------	---------

(4 & 5 AXLE) DRIVER - EQUIPMENT <i>TEAMSTERS JOINT COUNCIL NO. 10 ZONE A</i>	12/01/2016	\$33.44	\$10.91	\$0.00	\$0.00	\$44.35
---	------------	---------	---------	--------	--------	---------

Classification	Effective Date	Base Wage	Health	Pension	Supplemental Unemployment	Total Rate
ADS/SUBMERSIBLE PILOT <i>PILE DRIVER LOCAL 56 (ZONE 1)</i>	08/01/2015	\$88.29	\$9.80	\$0.00	\$0.00	\$98.09
For apprentice rates see "Apprentice- PILE DRIVER"						
ASPHALT/CONCRETE/CRUSHER PLANT-ON SITE <i>OPERATING ENGINEERS LOCAL 4</i>	12/01/2016	\$45.38	\$10.00	\$0.00	\$0.00	\$55.38
	06/01/2017	\$46.38	\$10.00	\$0.00	\$0.00	\$56.38
	12/01/2017	\$47.38	\$10.00	\$0.00	\$0.00	\$57.38
For apprentice rates see "Apprentice- OPERATING ENGINEERS"						
BACKHOE/FRONT-END LOADER <i>OPERATING ENGINEERS LOCAL 4</i>	12/01/2016	\$45.38	\$10.00	\$0.00	\$0.00	\$55.38
	06/01/2017	\$46.38	\$10.00	\$0.00	\$0.00	\$56.38
	12/01/2017	\$47.38	\$10.00	\$0.00	\$0.00	\$57.38
For apprentice rates see "Apprentice- OPERATING ENGINEERS"						
BULLDOZER/GRADER/SCRAPER <i>OPERATING ENGINEERS LOCAL 4</i>	12/01/2016	\$44.94	\$10.00	\$0.00	\$0.00	\$54.94
	06/01/2017	\$45.93	\$10.00	\$0.00	\$0.00	\$55.93
	12/01/2017	\$46.92	\$10.00	\$0.00	\$0.00	\$56.92
For apprentice rates see "Apprentice- OPERATING ENGINEERS"						
CLAM SHELLS/SLURRY BUCKETS/HEADING MACHINES <i>OPERATING ENGINEERS LOCAL 4</i>	12/01/2016	\$46.38	\$10.00	\$0.00	\$0.00	\$56.38
	06/01/2017	\$47.38	\$10.00	\$0.00	\$0.00	\$57.38
	12/01/2017	\$48.38	\$10.00	\$0.00	\$0.00	\$58.38
For apprentice rates see "Apprentice- OPERATING ENGINEERS"						
COMPRESSOR OPERATOR <i>OPERATING ENGINEERS LOCAL 4</i>	12/01/2016	\$31.17	\$10.00	\$0.00	\$0.00	\$41.17
	06/01/2017	\$31.86	\$10.00	\$0.00	\$0.00	\$41.86
	12/01/2017	\$32.55	\$10.00	\$0.00	\$0.00	\$42.55
For apprentice rates see "Apprentice- OPERATING ENGINEERS"						
DIVER <i>PILE DRIVER LOCAL 56 (ZONE 1)</i>	08/01/2015	\$58.86	\$9.80	\$0.00	\$0.00	\$68.66
For apprentice rates see "Apprentice- PILE DRIVER"						
DIVER TENDER <i>PILE DRIVER LOCAL 56 (ZONE 1)</i>	08/01/2015	\$42.04	\$9.80	\$0.00	\$0.00	\$51.84
For apprentice rates see "Apprentice- PILE DRIVER"						
DIVER TENDER (EFFLUENT) <i>PILE DRIVER LOCAL 56 (ZONE 1)</i>	08/01/2015	\$63.06	\$9.80	\$0.00	\$0.00	\$72.86
For apprentice rates see "Apprentice- PILE DRIVER"						
DIVER/SLURRY (EFFLUENT) <i>PILE DRIVER LOCAL 56 (ZONE 1)</i>	08/01/2015	\$88.23	\$9.80	\$0.00	\$0.00	\$98.03
For apprentice rates see "Apprentice- PILE DRIVER"						
FLAGGER & SIGNALER <i>LABORERS - ZONE 1</i>	12/01/2016	\$20.50	\$7.60	\$0.00	\$0.00	\$28.10
For apprentice rates see "Apprentice- LABORER"						
FORK LIFT/CHERRY PICKER <i>OPERATING ENGINEERS LOCAL 4</i>	12/01/2016	\$45.38	\$10.00	\$0.00	\$0.00	\$55.38
	06/01/2017	\$46.38	\$10.00	\$0.00	\$0.00	\$56.38
	12/01/2017	\$47.38	\$10.00	\$0.00	\$0.00	\$57.38
For apprentice rates see "Apprentice- OPERATING ENGINEERS"						
GENERATOR/LIGHTING PLANT/HEATERS <i>OPERATING ENGINEERS LOCAL 4</i>	12/01/2016	\$31.17	\$10.00	\$0.00	\$0.00	\$41.17
	06/01/2017	\$31.86	\$10.00	\$0.00	\$0.00	\$41.86
	12/01/2017	\$32.55	\$10.00	\$0.00	\$0.00	\$42.55
For apprentice rates see "Apprentice- OPERATING ENGINEERS"						
HOISTING ENGINEER/CRANES/GRADALLS <i>OPERATING ENGINEERS LOCAL 4</i>	12/01/2016	\$45.38	\$10.00	\$0.00	\$0.00	\$55.38
	06/01/2017	\$46.38	\$10.00	\$0.00	\$0.00	\$56.38
	12/01/2017	\$47.38	\$10.00	\$0.00	\$0.00	\$57.38

Classification

Effective Date Base Wage Health Pension Supplemental Unemployment Total Rate

Apprentice - OPERATING ENGINEERS - Local 4

Effective Date - 12/01/2016

Step	percent	Apprentice Base Wage	Health	Pension	Supplemental Unemployment	Total Rate
1	55	\$24.96	\$10.00	\$0.00	\$0.00	\$34.96
2	60	\$27.23	\$10.00	\$0.00	\$0.00	\$37.23
3	65	\$29.50	\$10.00	\$0.00	\$0.00	\$39.50
4	70	\$31.77	\$10.00	\$0.00	\$0.00	\$41.77
5	75	\$34.04	\$10.00	\$0.00	\$0.00	\$44.04
6	80	\$36.30	\$10.00	\$0.00	\$0.00	\$46.30
7	85	\$38.57	\$10.00	\$0.00	\$0.00	\$48.57
8	90	\$40.84	\$10.00	\$0.00	\$0.00	\$50.84

Effective Date - 06/01/2017

Step	percent	Apprentice Base Wage	Health	Pension	Supplemental Unemployment	Total Rate
1	55	\$25.51	\$10.00	\$0.00	\$0.00	\$35.51
2	60	\$27.83	\$10.00	\$0.00	\$0.00	\$37.83
3	65	\$30.15	\$10.00	\$0.00	\$0.00	\$40.15
4	70	\$32.47	\$10.00	\$0.00	\$0.00	\$42.47
5	75	\$34.79	\$10.00	\$0.00	\$0.00	\$44.79
6	80	\$37.10	\$10.00	\$0.00	\$0.00	\$47.10
7	85	\$39.42	\$10.00	\$0.00	\$0.00	\$49.42
8	90	\$41.74	\$10.00	\$0.00	\$0.00	\$51.74

Notes:

Apprentice to Journeyworker Ratio:1:6

LABORER	12/01/2016	\$36.35	\$7.60	\$0.00	\$0.00	\$43.95
LABORERS - ZONE 1	06/01/2017	\$37.35	\$7.60	\$0.00	\$0.00	\$44.95
	12/01/2017	\$38.20	\$7.60	\$0.00	\$0.00	\$45.80
	06/01/2018	\$39.15	\$7.60	\$0.00	\$0.00	\$46.75
	12/01/2018	\$40.10	\$7.60	\$0.00	\$0.00	\$47.70
	06/01/2019	\$41.10	\$7.60	\$0.00	\$0.00	\$48.70
	12/01/2019	\$42.10	\$7.60	\$0.00	\$0.00	\$49.70

Classification

Effective Date Base Wage Health Pension Supplemental Unemployment Total Rate

Apprentice - LABORER - Zone 1

Effective Date - 12/01/2016

Step	percent	Apprentice Base Wage	Health	Pension	Supplemental Unemployment	Total Rate
1	60	\$21.81	\$7.60	\$0.00	\$0.00	\$29.41
2	70	\$25.45	\$7.60	\$0.00	\$0.00	\$33.05
3	80	\$29.08	\$7.60	\$0.00	\$0.00	\$36.68
4	90	\$32.72	\$7.60	\$0.00	\$0.00	\$40.32

Effective Date - 06/01/2017

Step	percent	Apprentice Base Wage	Health	Pension	Supplemental Unemployment	Total Rate
1	60	\$22.41	\$7.60	\$0.00	\$0.00	\$30.01
2	70	\$26.15	\$7.60	\$0.00	\$0.00	\$33.75
3	80	\$29.88	\$7.60	\$0.00	\$0.00	\$37.48
4	90	\$33.62	\$7.60	\$0.00	\$0.00	\$41.22

Notes:

Apprentice to Journeyworker Ratio:1:5

OILER (OTHER THAN TRUCK CRANES,GRADALLS) OPERATING ENGINEERS LOCAL 4	12/01/2016	\$22.96	\$10.00	\$0.00	\$0.00	\$32.96
	06/01/2017	\$23.47	\$10.00	\$0.00	\$0.00	\$33.47
	12/01/2017	\$23.99	\$10.00	\$0.00	\$0.00	\$33.99

For apprentice rates see "Apprentice- OPERATING ENGINEERS"

OILER (TRUCK CRANES, GRADALLS) OPERATING ENGINEERS LOCAL 4	12/01/2016	\$26.94	\$10.00	\$0.00	\$0.00	\$36.94
	06/01/2017	\$27.54	\$10.00	\$0.00	\$0.00	\$37.54
	12/01/2017	\$28.15	\$10.00	\$0.00	\$0.00	\$38.15

For apprentice rates see "Apprentice- OPERATING ENGINEERS"

OTHER POWER DRIVEN EQUIPMENT - CLASS II OPERATING ENGINEERS LOCAL 4	12/01/2016	\$44.94	\$10.00	\$0.00	\$0.00	\$54.94
	06/01/2017	\$45.93	\$10.00	\$0.00	\$0.00	\$55.93
	12/01/2017	\$46.92	\$10.00	\$0.00	\$0.00	\$56.92

For apprentice rates see "Apprentice- OPERATING ENGINEERS"

PANEL & PICKUP TRUCKS DRIVER TEAMSTERS JOINT COUNCIL NO. 10 ZONE A	12/01/2016	\$33.08	\$10.91	\$0.00	\$0.00	\$43.99
---	------------	---------	---------	--------	--------	---------

POWER SHOVEL/DERRICK/TRENCHING MACHINE OPERATING ENGINEERS LOCAL 4	12/01/2016	\$45.38	\$10.00	\$0.00	\$0.00	\$55.38
	06/01/2017	\$46.38	\$10.00	\$0.00	\$0.00	\$56.38
	12/01/2017	\$47.38	\$10.00	\$0.00	\$0.00	\$57.38

For apprentice rates see "Apprentice- OPERATING ENGINEERS"

PUMP OPERATOR (CONCRETE) OPERATING ENGINEERS LOCAL 4	12/01/2016	\$45.38	\$10.00	\$0.00	\$0.00	\$55.38
	06/01/2017	\$46.38	\$10.00	\$0.00	\$0.00	\$56.38
	12/01/2017	\$47.38	\$10.00	\$0.00	\$0.00	\$57.38

For apprentice rates see "Apprentice- OPERATING ENGINEERS"

PUMP OPERATOR (DEWATERING, OTHER) OPERATING ENGINEERS LOCAL 4	12/01/2016	\$31.17	\$10.00	\$0.00	\$0.00	\$41.17
	06/01/2017	\$31.86	\$10.00	\$0.00	\$0.00	\$41.86
	12/01/2017	\$32.55	\$10.00	\$0.00	\$0.00	\$42.55

For apprentice rates see "Apprentice- OPERATING ENGINEERS"

Classification	Effective Date	Base Wage	Health	Pension	Supplemental Unemployment	Total Rate
ROLLER/SPREADER/MULCHING MACHINE <i>OPERATING ENGINEERS LOCAL 4</i>	12/01/2016	\$44.94	\$10.00	\$0.00	\$0.00	\$54.94
	06/01/2017	\$45.93	\$10.00	\$0.00	\$0.00	\$55.93
	12/01/2017	\$46.92	\$10.00	\$0.00	\$0.00	\$56.92
For apprentice rates see "Apprentice- OPERATING ENGINEERS"						
SPECIALIZED EARTH MOVING EQUIP < 35 TONS <i>TEAMSTERS JOINT COUNCIL NO. 10 ZONE A</i>	12/01/2016	\$33.54	\$10.91	\$0.00	\$0.00	\$44.45
SPECIALIZED EARTH MOVING EQUIP > 35 TONS <i>TEAMSTERS JOINT COUNCIL NO. 10 ZONE A</i>	12/01/2016	\$33.83	\$10.91	\$0.00	\$0.00	\$44.74
TRACTORS/PORTABLE STEAM GENERATORS <i>OPERATING ENGINEERS LOCAL 4</i>	12/01/2016	\$44.94	\$10.00	\$0.00	\$0.00	\$54.94
	06/01/2017	\$45.93	\$10.00	\$0.00	\$0.00	\$55.93
	12/01/2017	\$46.92	\$10.00	\$0.00	\$0.00	\$56.92
For apprentice rates see "Apprentice- OPERATING ENGINEERS"						
TRAILERS FOR EARTH MOVING EQUIPMENT <i>TEAMSTERS JOINT COUNCIL NO. 10 ZONE A</i>	12/01/2016	\$34.12	\$10.91	\$0.00	\$0.00	\$45.03
TREE TRIMMER <i>OUTSIDE ELECTRICAL WORKERS - EAST LOCAL 104</i>	01/31/2016	\$18.51	\$3.55	\$0.00	\$0.00	\$22.06
This classification applies only to tree work done: (a) for a utility company, R.E.A. cooperative, or railroad or coal mining company, and (b) for the purpose of operating, maintaining, or repairing the utility company's equipment, and (c) by a person who is using hand or mechanical cutting methods and is not on the ground. This classification does not apply to wholesale tree removal.						
TREE TRIMMER GROUNDMAN <i>OUTSIDE ELECTRICAL WORKERS - EAST LOCAL 104</i>	01/31/2016	\$16.32	\$3.55	\$0.00	\$0.00	\$19.87
This classification applies only to tree work done: (a) for a utility company, R.E.A. cooperative, or railroad or coal mining company, and (b) for the purpose of operating, maintaining, or repairing the utility company's equipment, and (c) by a person who is using hand or mechanical cutting methods and is on the ground. This classification does not apply to wholesale tree removal.						
VAC-HAUL/CATCH BASIN CLEANING <i>TEAMSTERS JOINT COUNCIL NO. 10 ZONE A</i>	12/01/2016	\$33.54	\$10.91	\$0.00	\$0.00	\$44.45

Additional Apprentice Information:

Minimum wage rates for apprentices employed on public works projects are listed above as a percentage of the pre-determined hourly wage rate established by the Commissioner under the provisions of the M.G.L. c. 149, ss. 26-27D. Apprentice ratios are established by the Division of Apprenticeship Training pursuant to M.G.L. c. 23, ss. 11E-11L.

All apprentices must be registered with the Division of Apprenticeship Training in accordance with M.G.L. c. 23, ss. 11E-11L.

All steps are six months (1000 hours.)

Ratios are expressed in allowable number of apprentices to journeymen or fraction thereof, unless otherwise specified.

** Multiple ratios are listed in the comment field.

*** APP to JM; 1:1, 2:2, 2:3, 3:4, 4:4, 4:5, 4:6, 5:7, 6:7, 6:8, 6:9, 7:10, 8:10, 8:11, 8:12, 9:13, 10:13, 10:14, etc.

**** APP to JM; 1:1, 1:2, 2:3, 2:4, 3:5, 4:6, 4:7, 5:8, 6:9, 6:10, 7:11, 8:12, 8:13, 9:14, 10:15, 10:16, etc.

2017 Water Distribution System Improvements

Specification Appendix

Water, Sewer and Drain Record Plans for the Project Locations

- Bow Street
- Mill Street
- Spring Street
- Burch Street

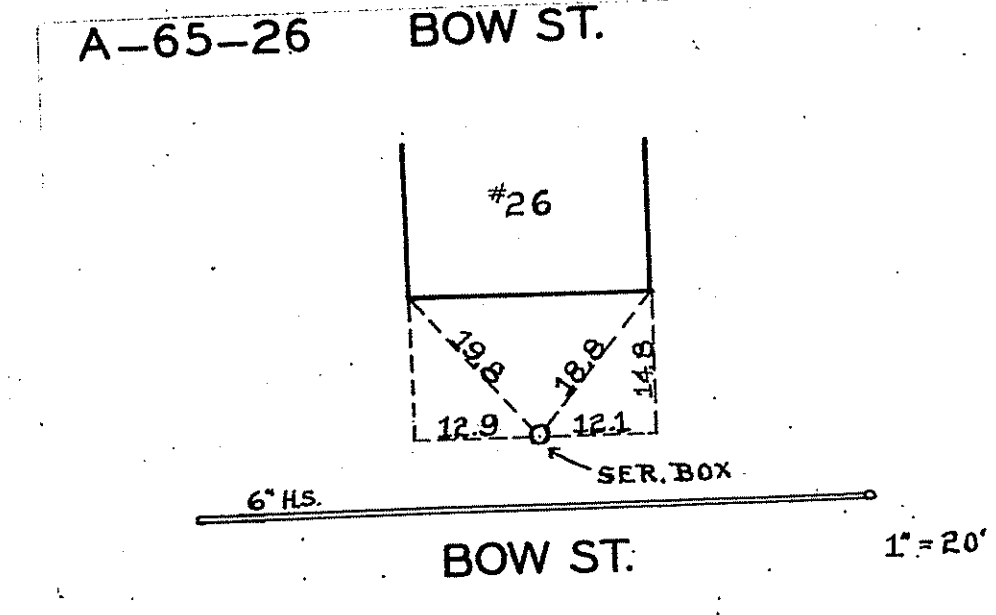
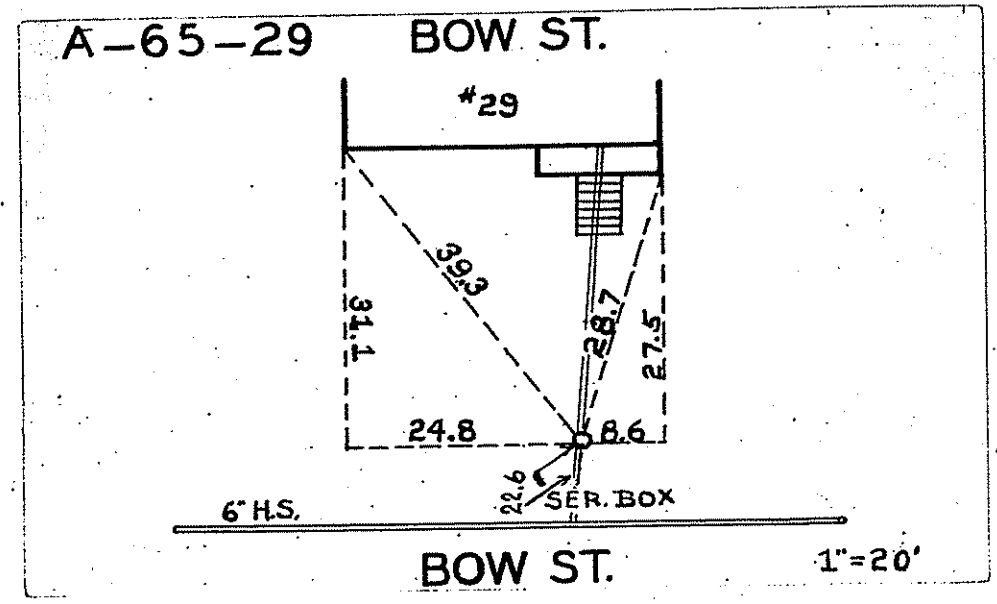
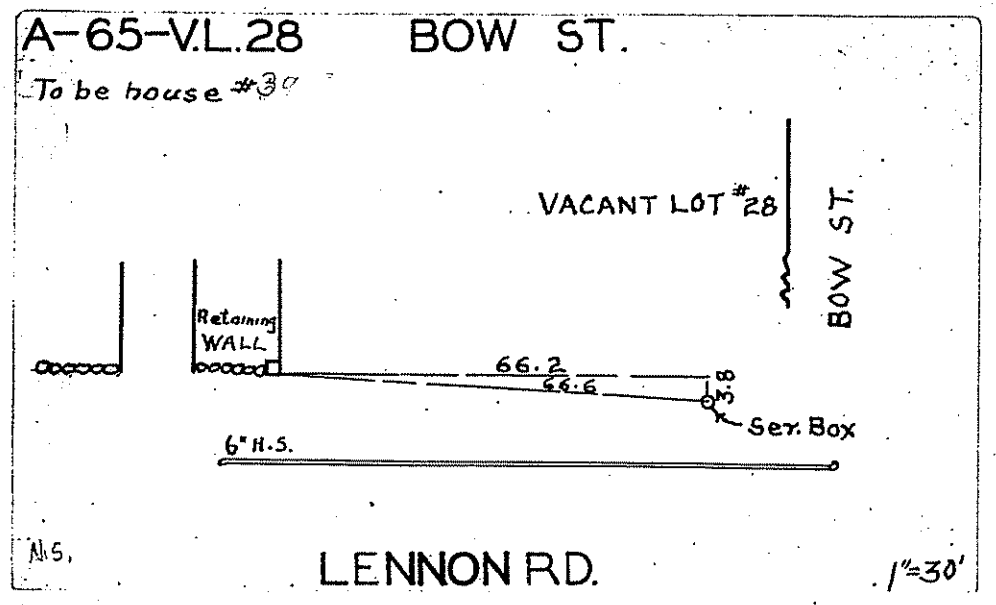
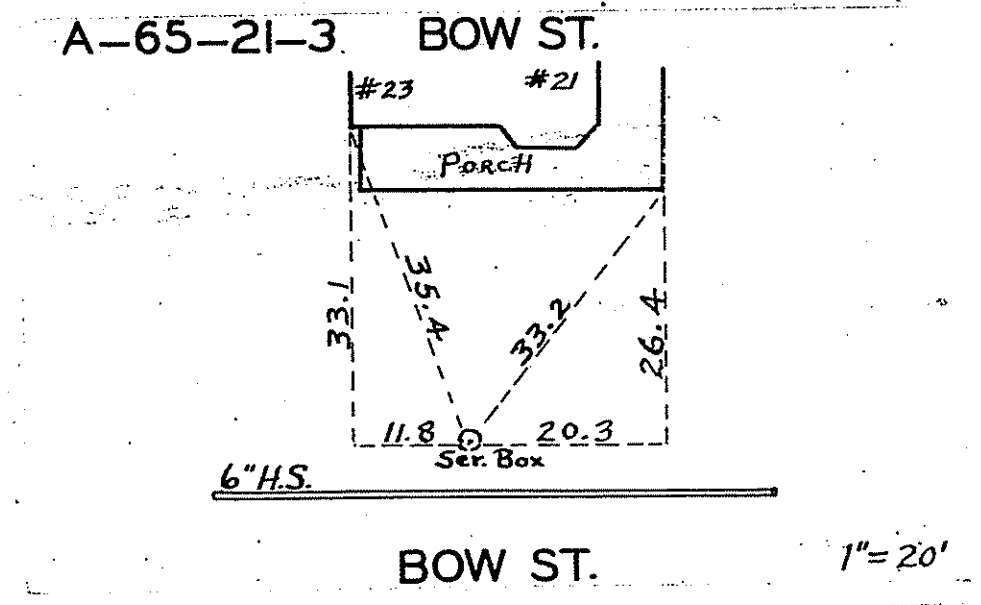
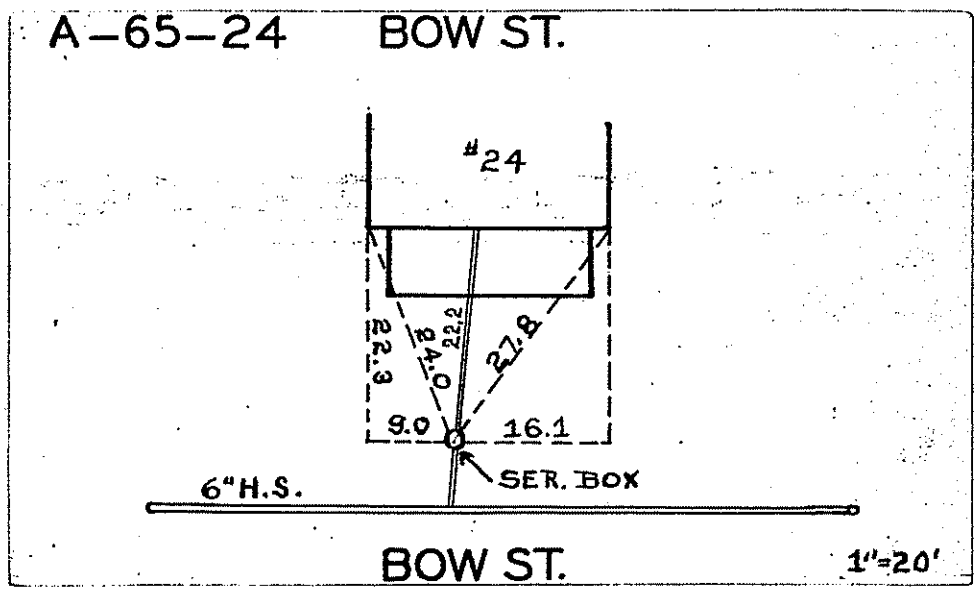
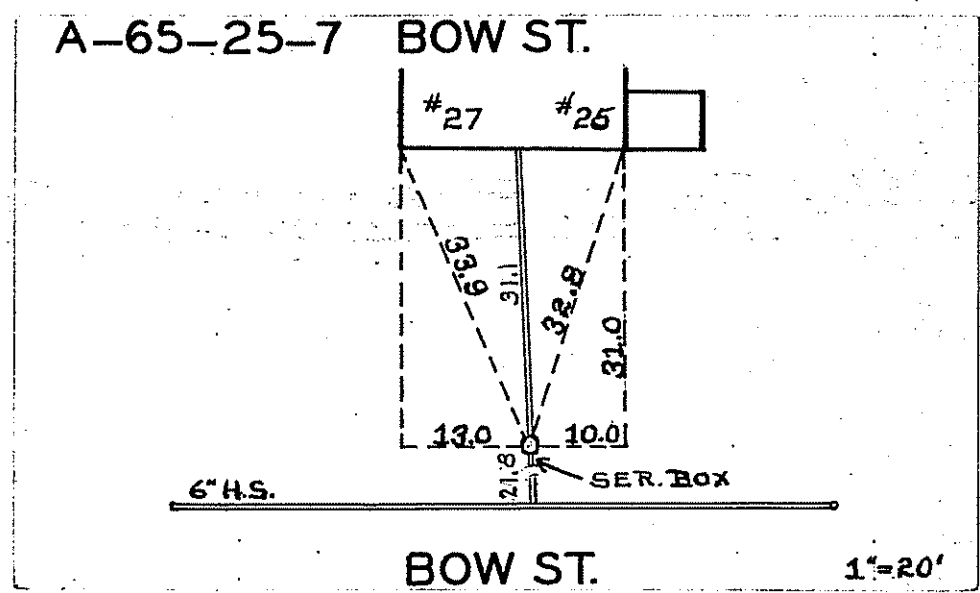
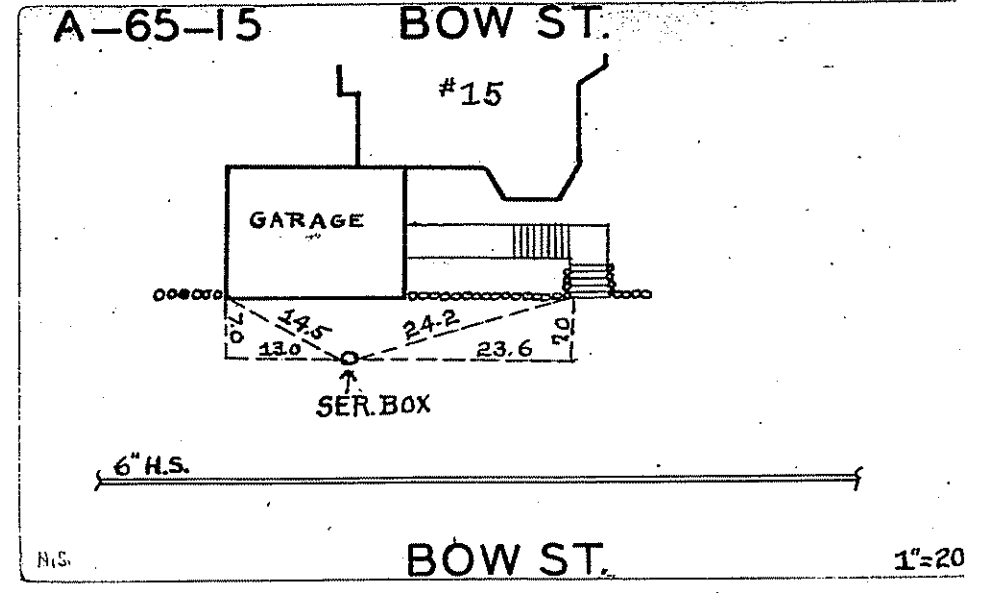
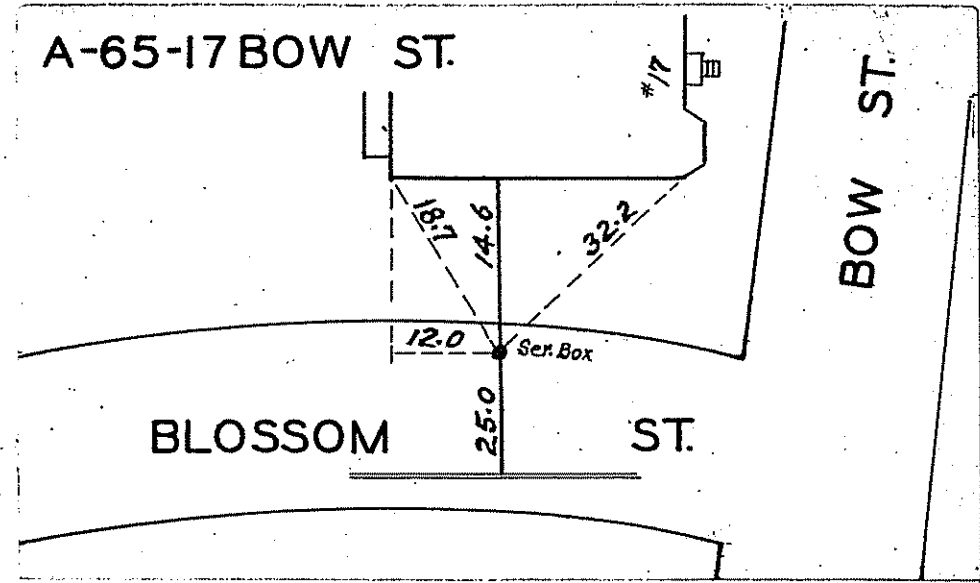
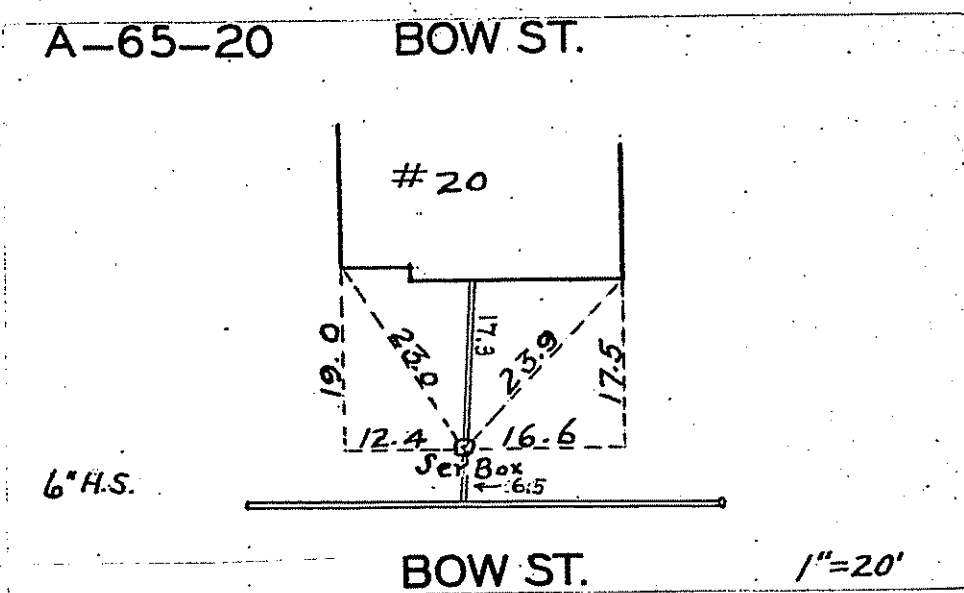

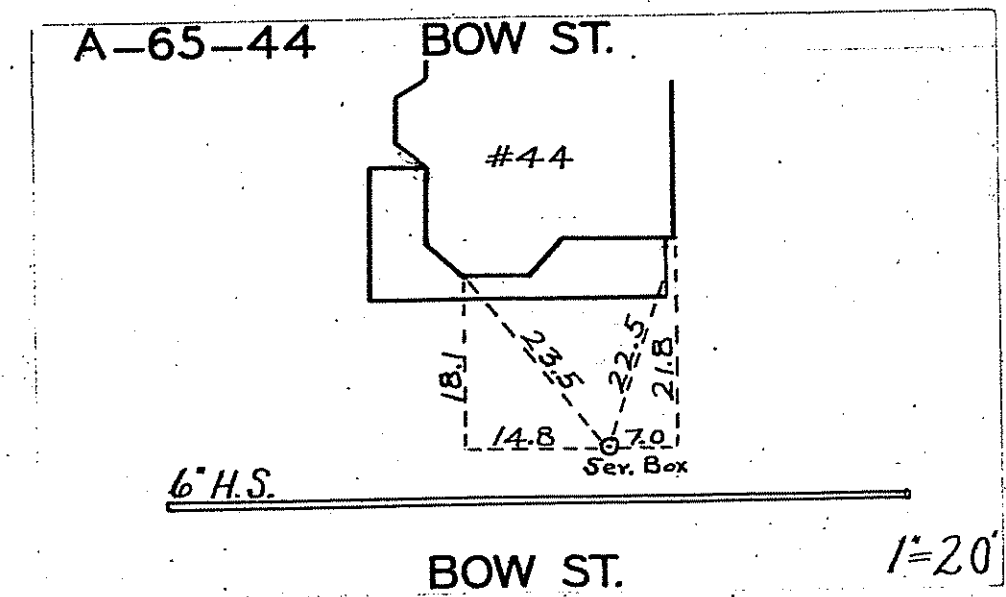
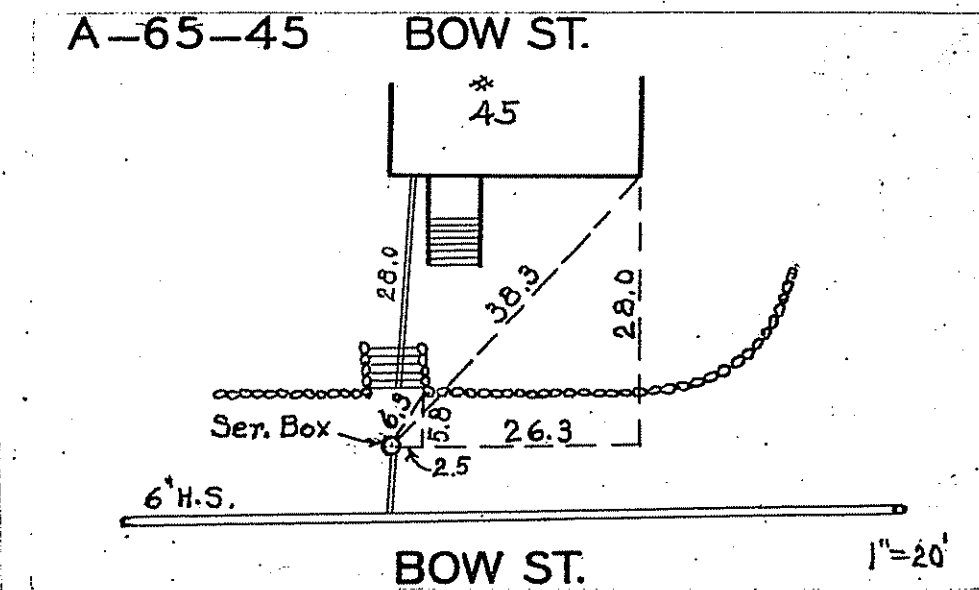
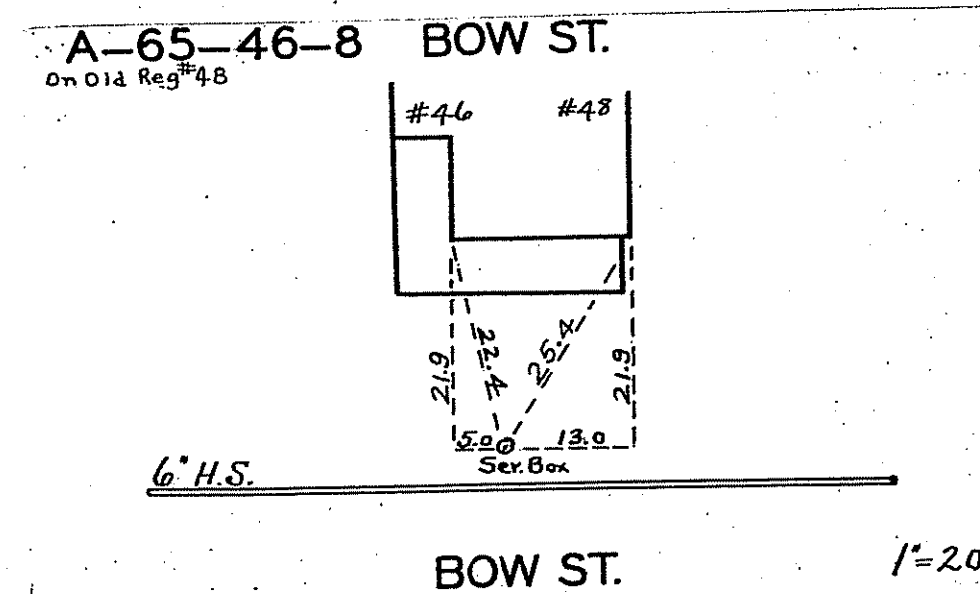
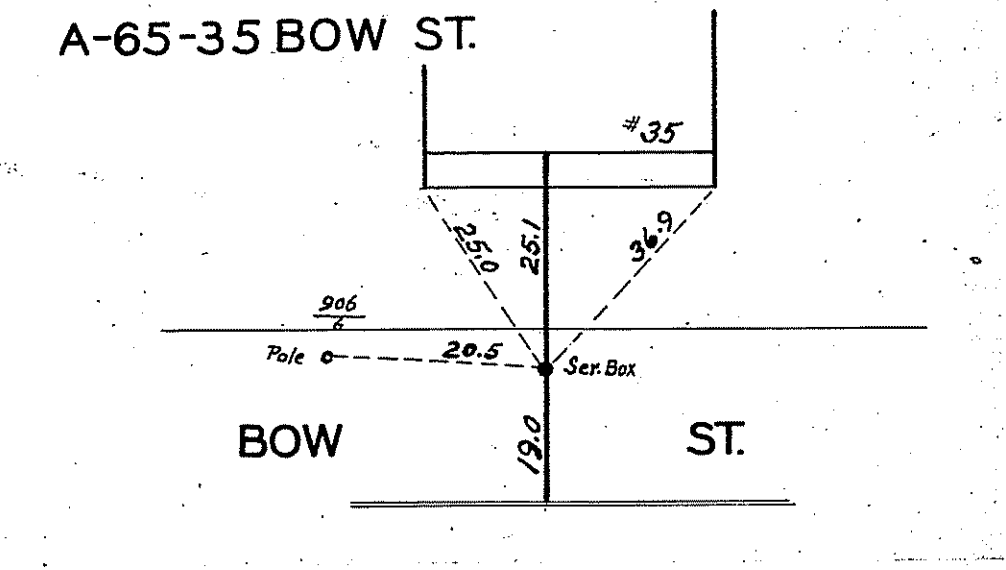
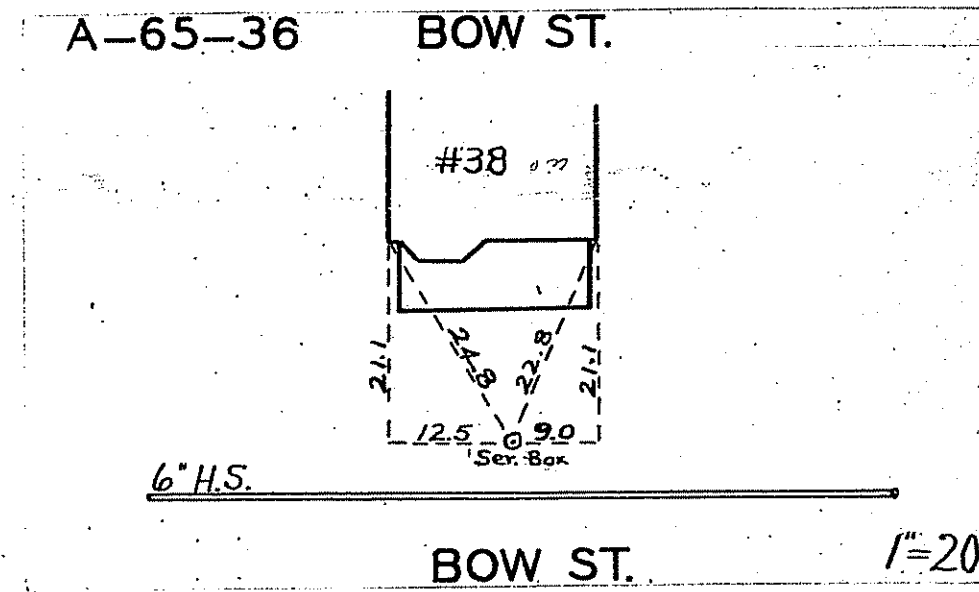
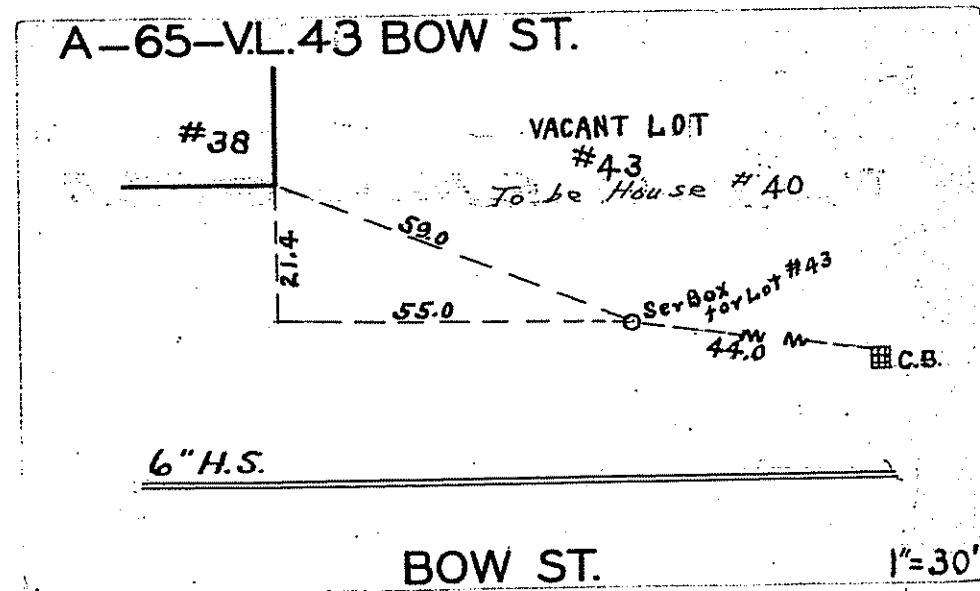
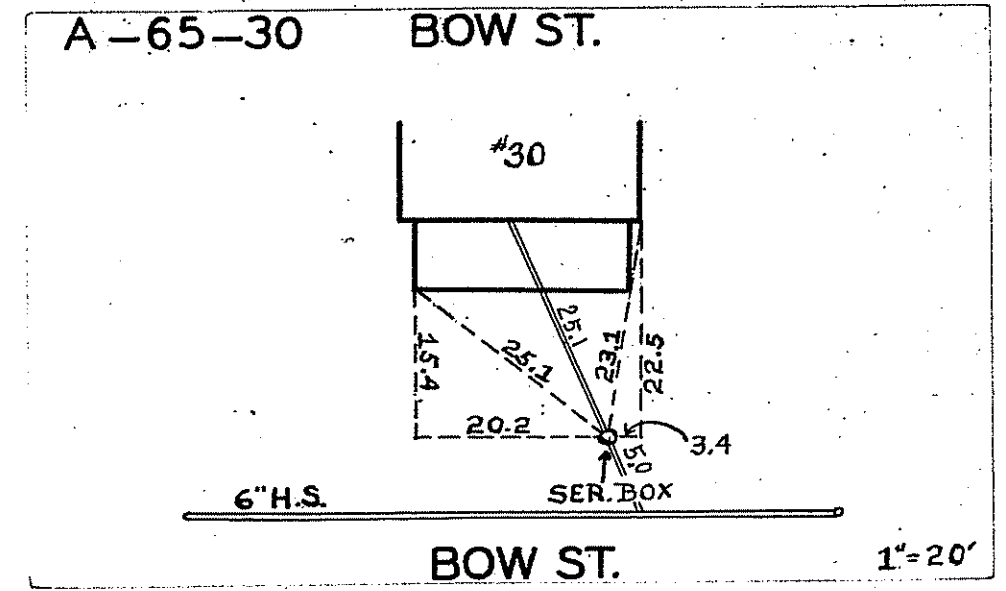
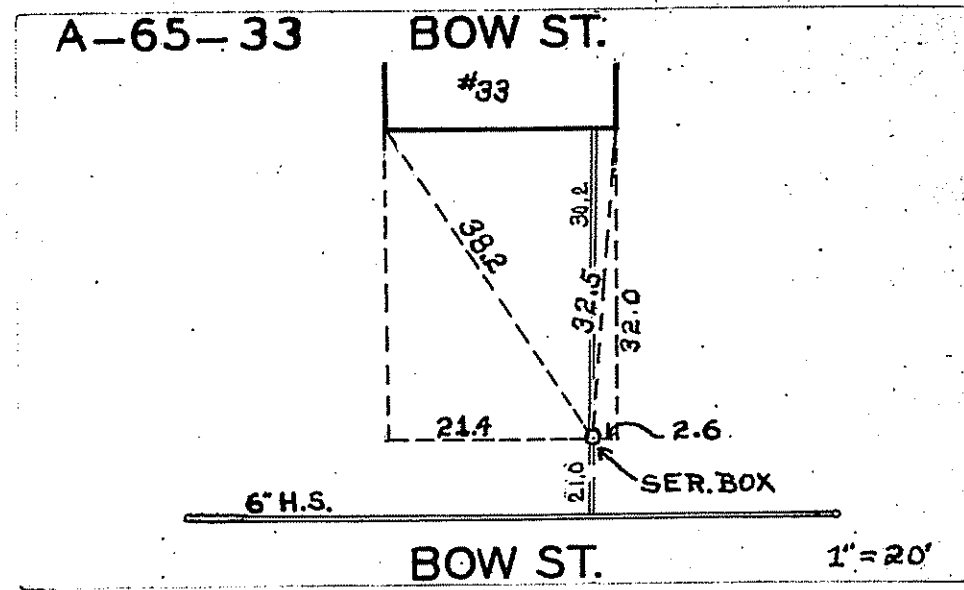
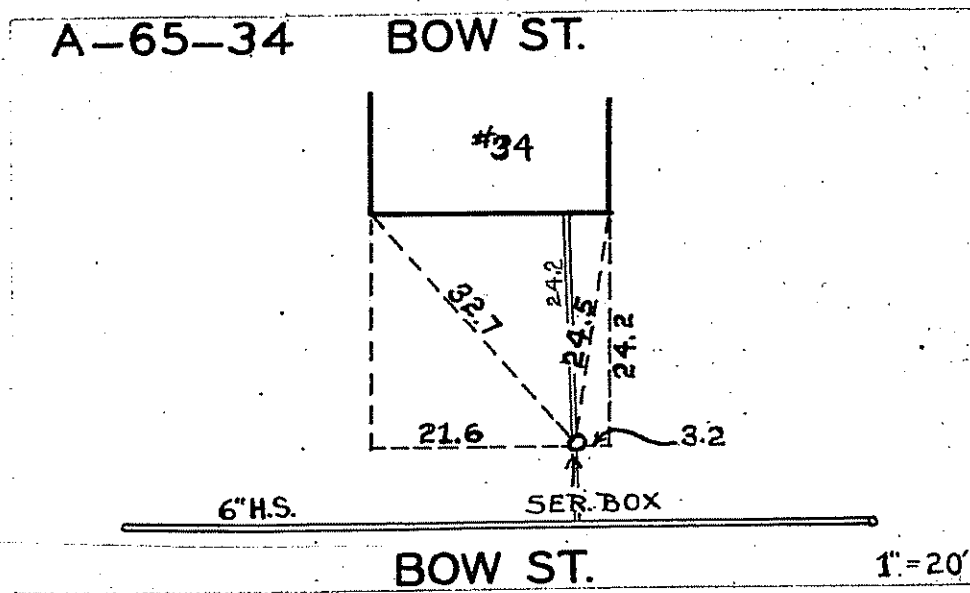

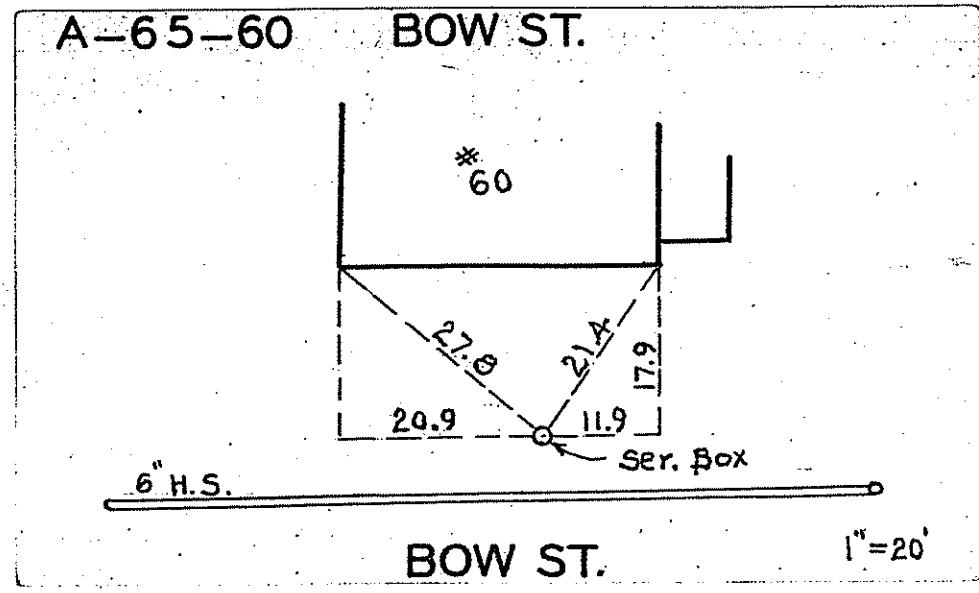
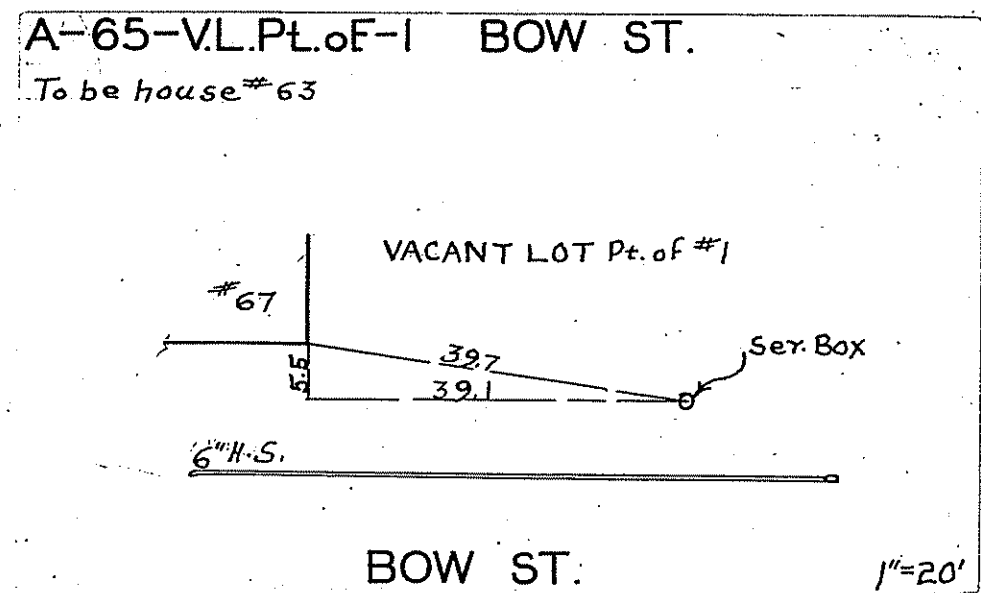
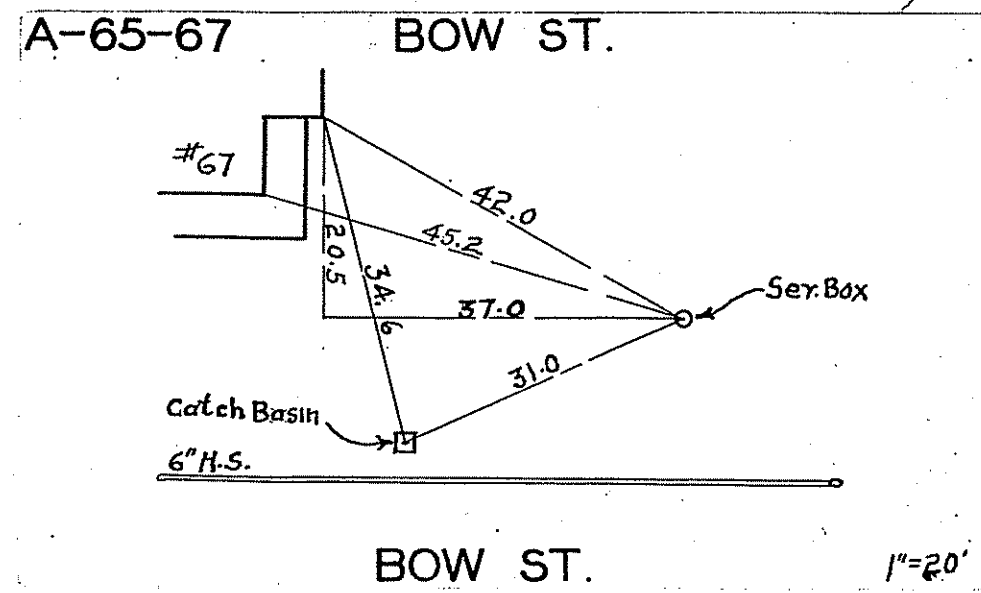
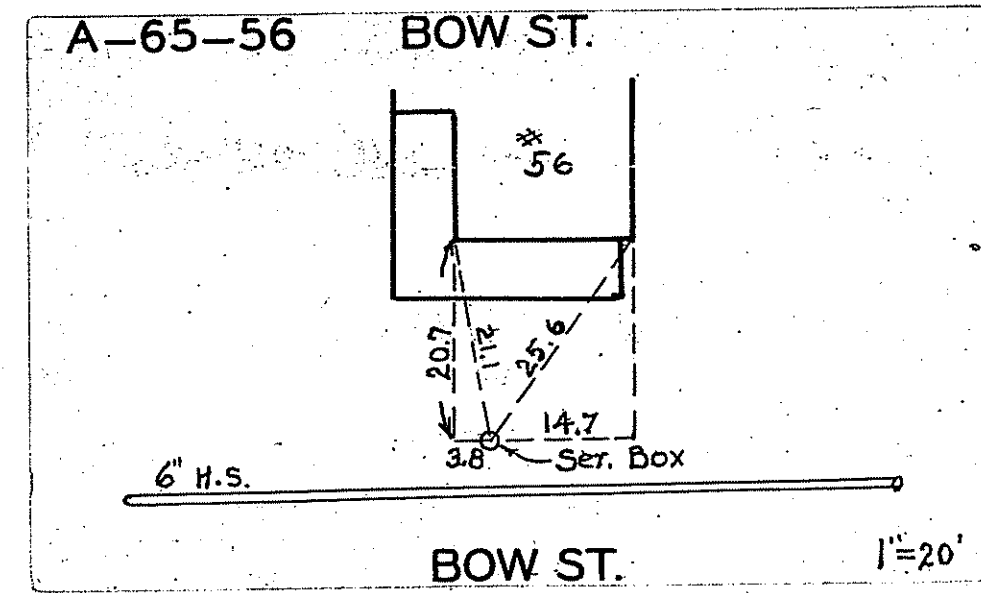
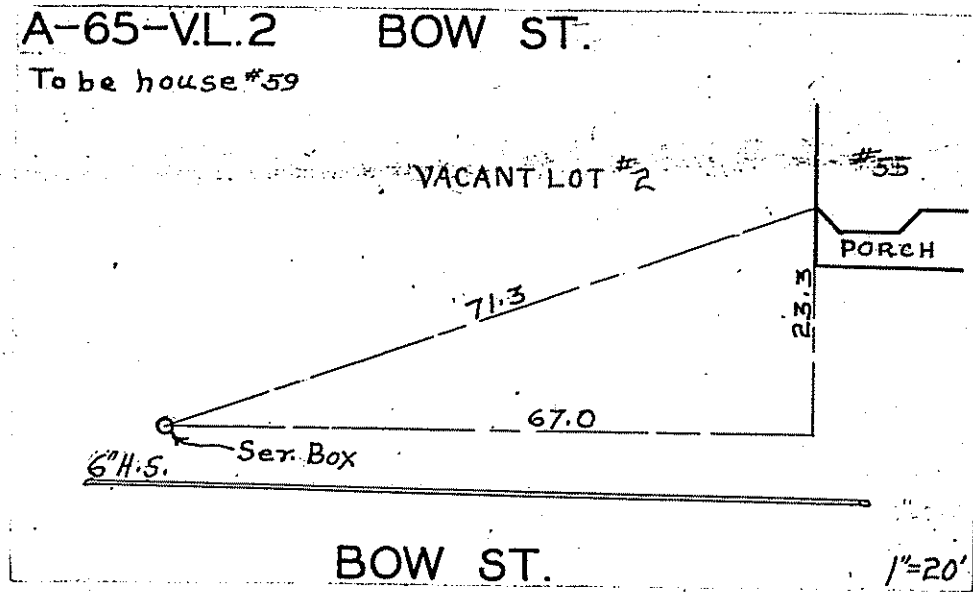
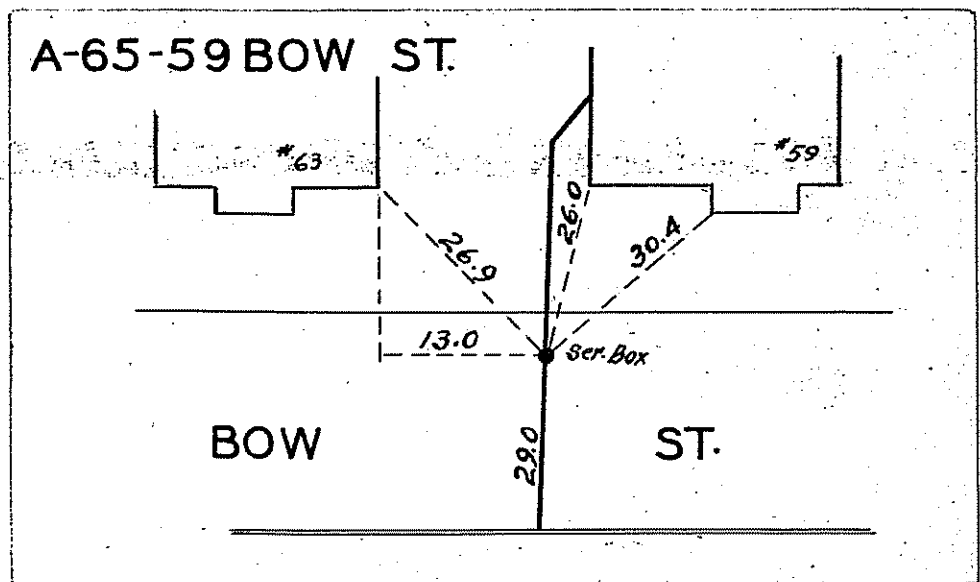
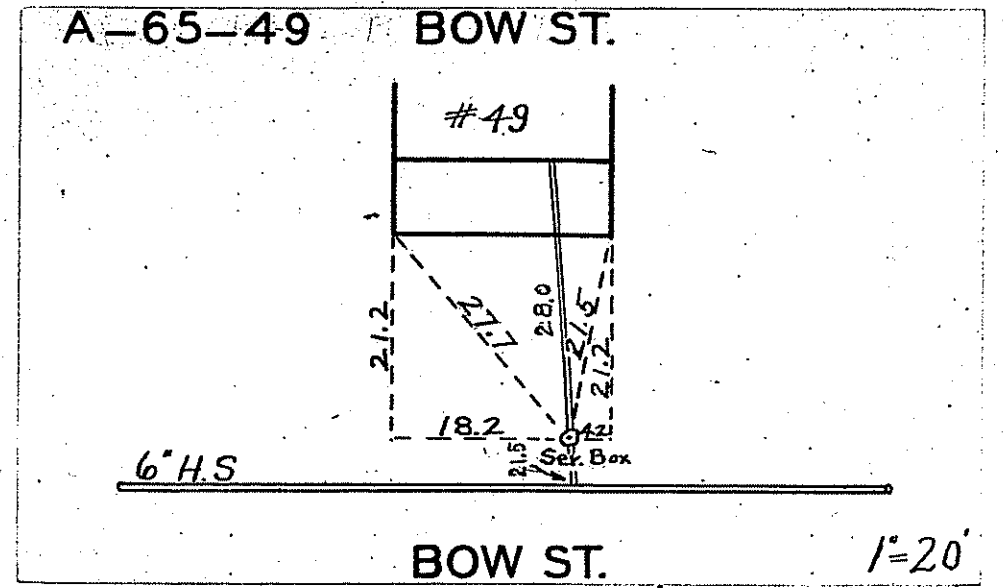
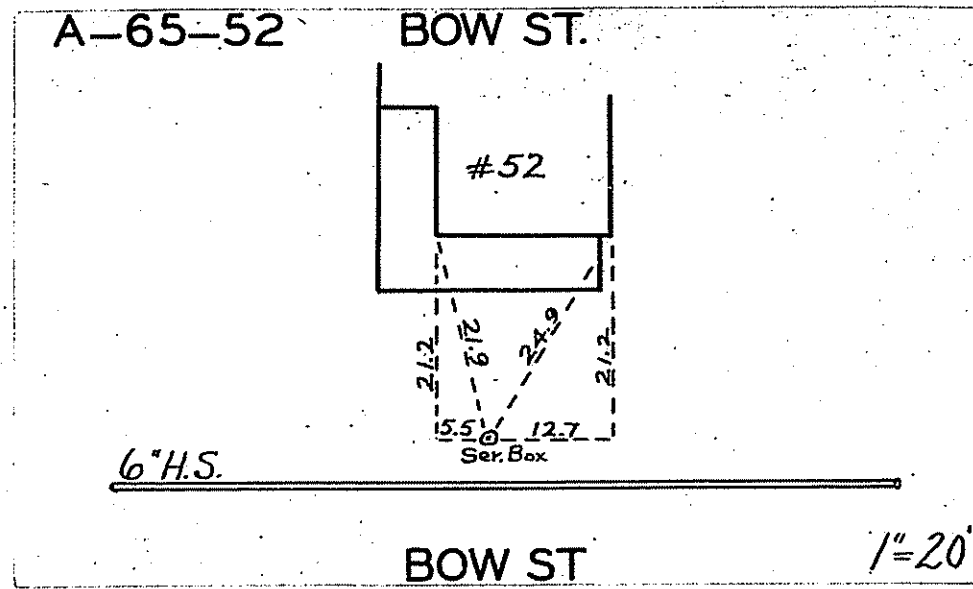
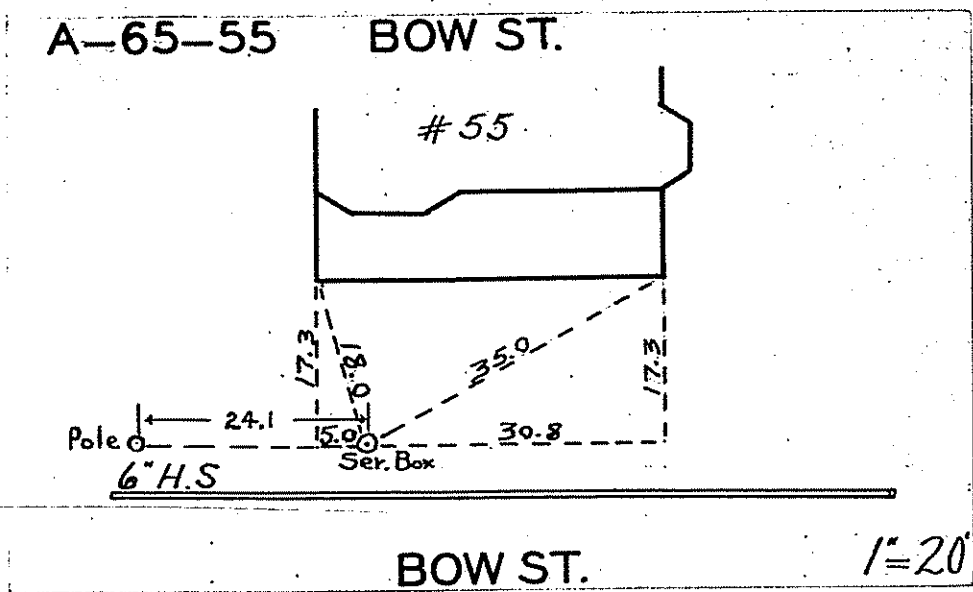

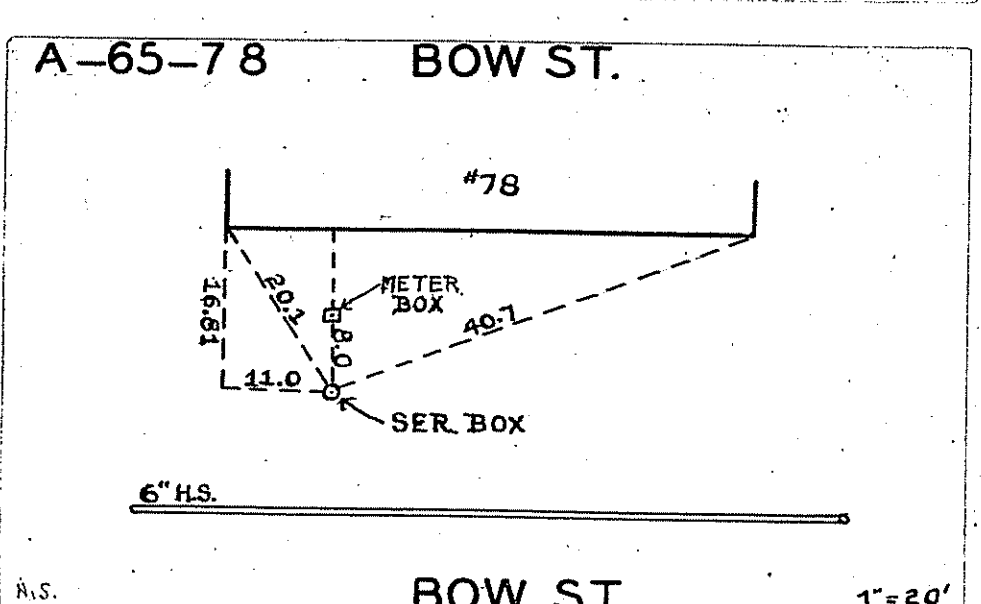
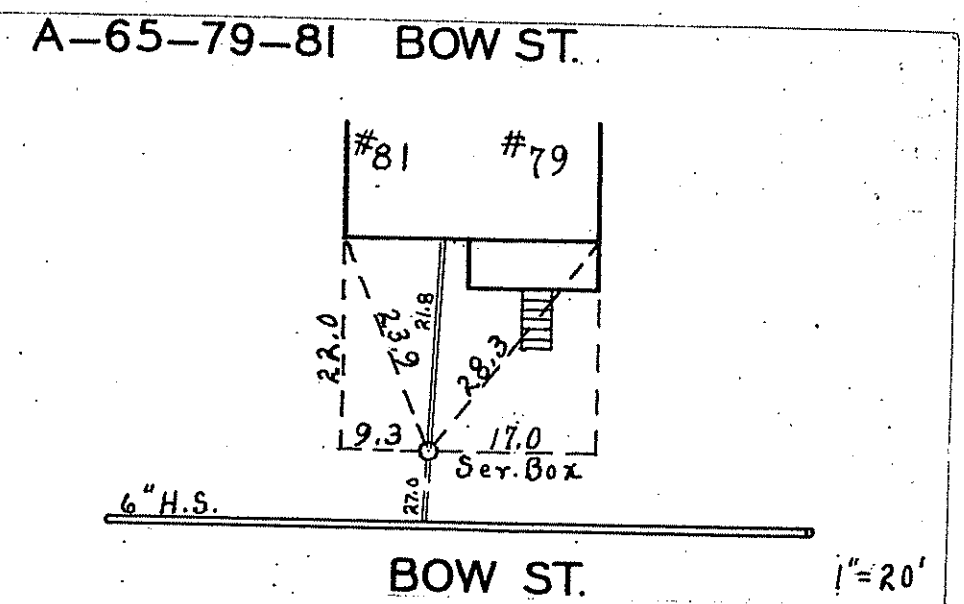
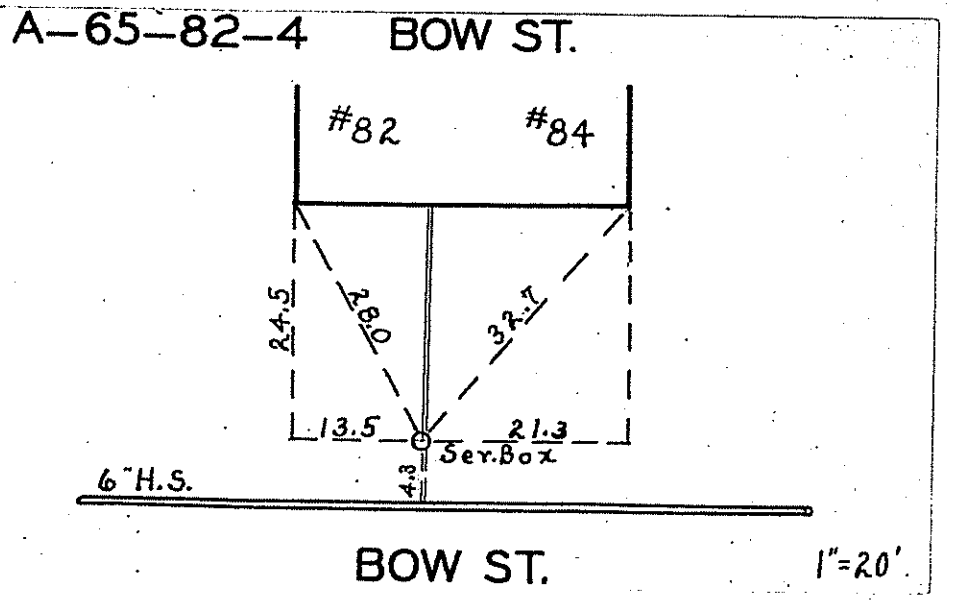
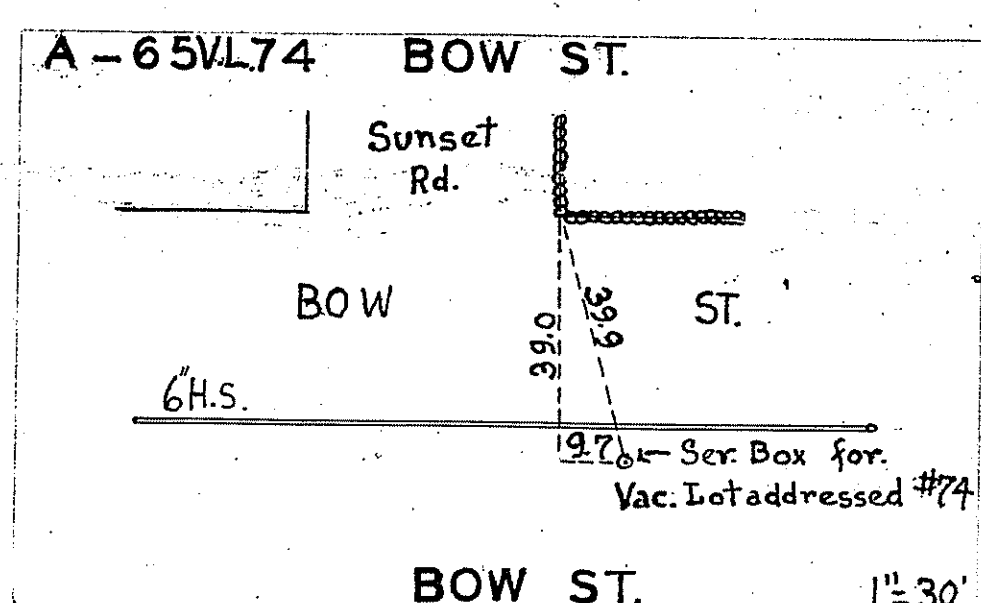
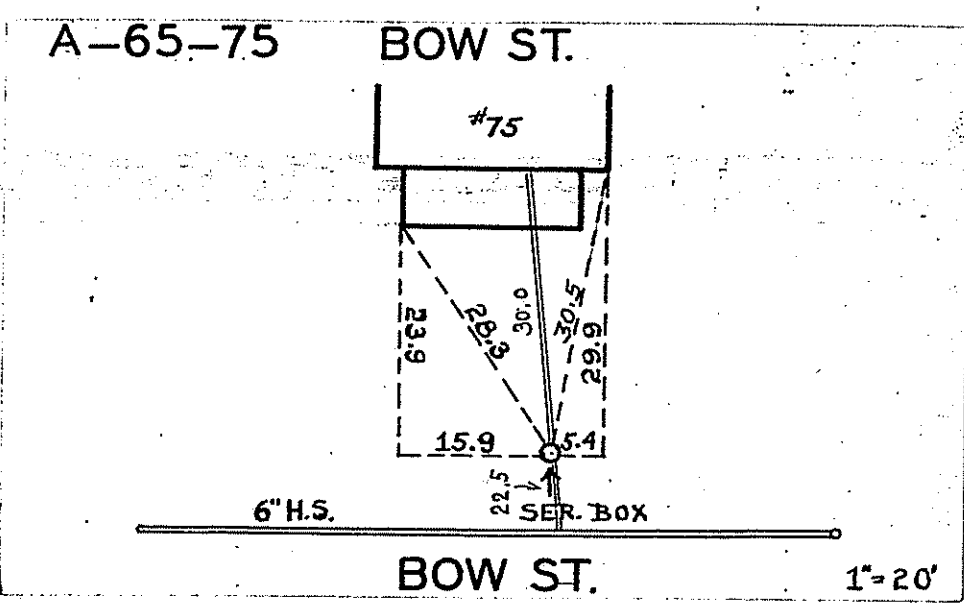
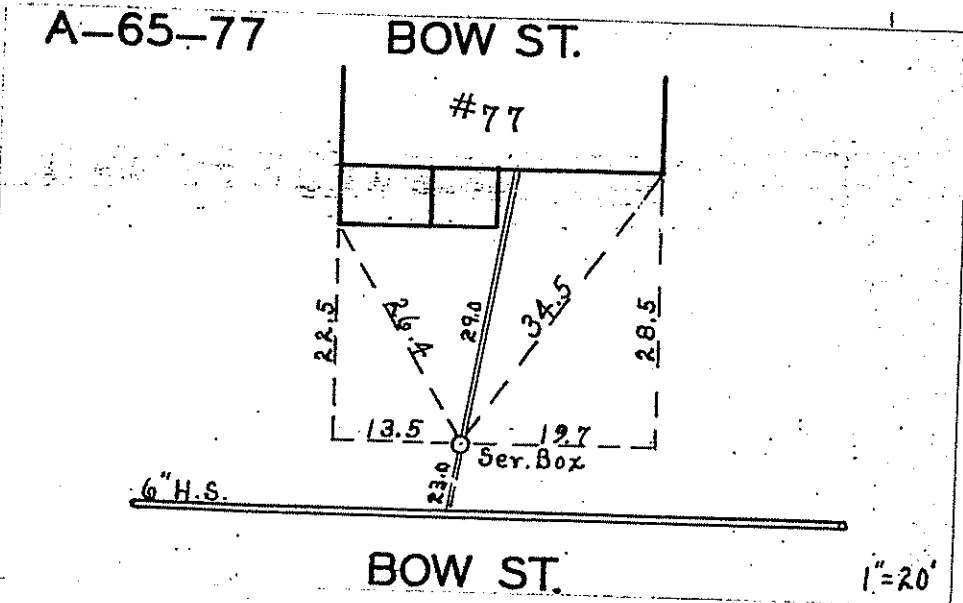
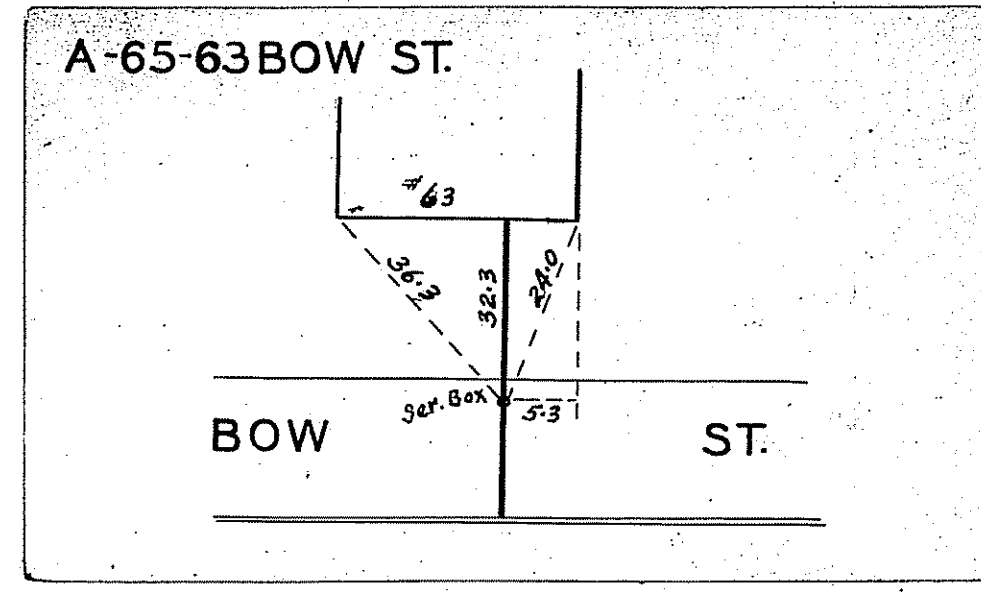
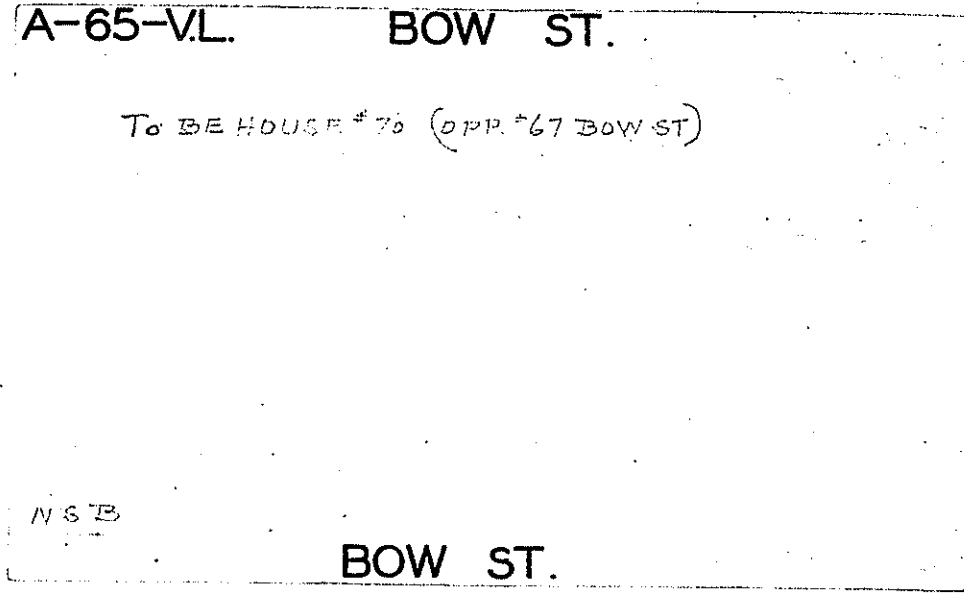
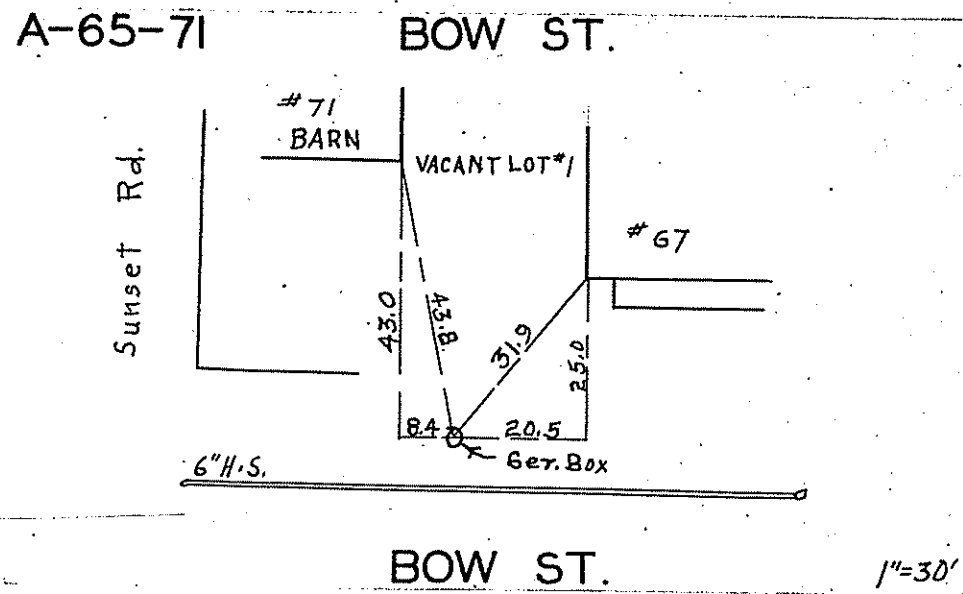

A-65-90-2 BOW ST.

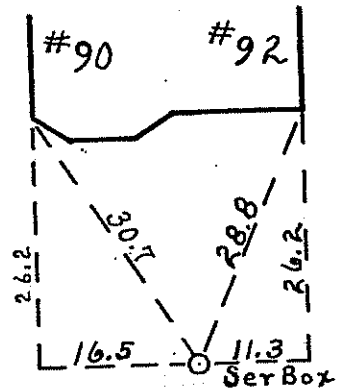

6" H.S.

BOW ST.

1"=20'

A-65-86-8 BOW ST.

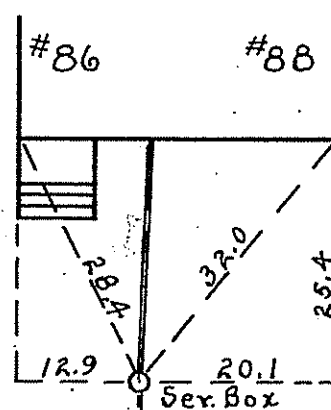

6" H.S.

BOW ST.

1"=20'

A-65-83-5 BOW ST.

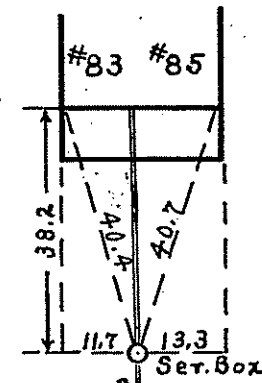

6" H.S.

BOW ST.

1"=30'

A-65-97 BOW ST.

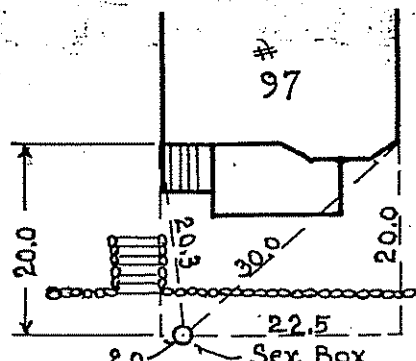

6" H.S.

BOW ST.

1"=20'

A-65-96-8 BOW ST.

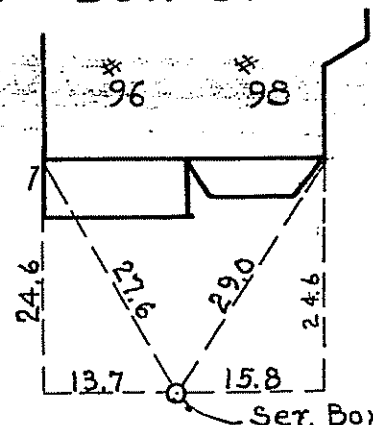

6" H.S.

BOW ST.

1"=20'

A-65-95 BOW ST.

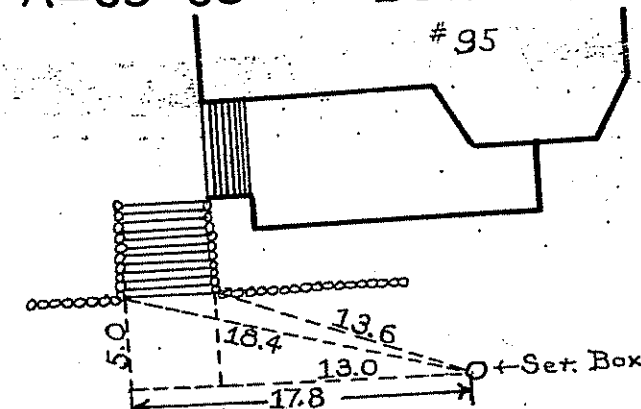

6" H.S.

BOW ST.

1"=1'

A-65-V.L.1 BOW ST.

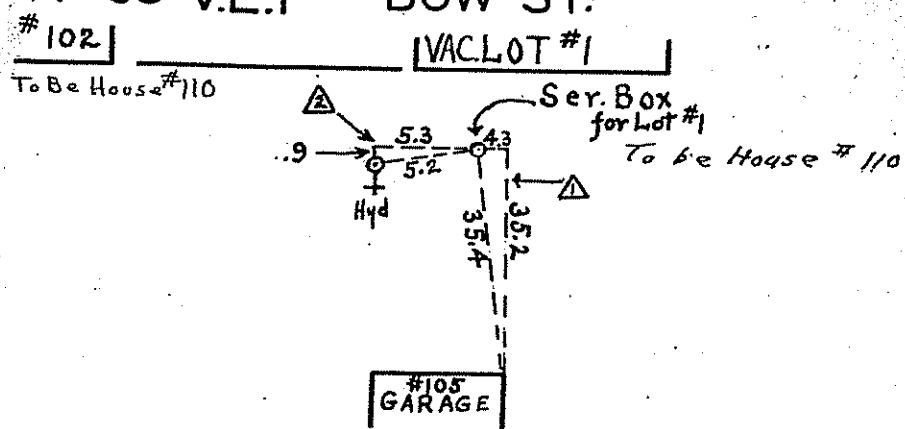

6" H.S.

BOW ST.

1"=30'
1"=10'

A-65-102 BOW ST.

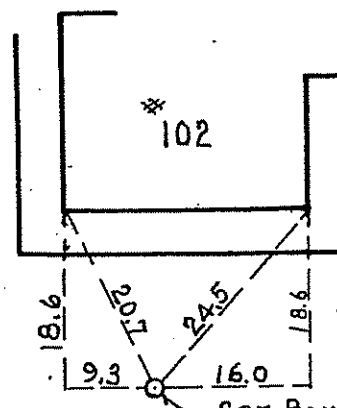

6" H.S.

BOW ST.

1"=20'

A-65-99 BOW ST.

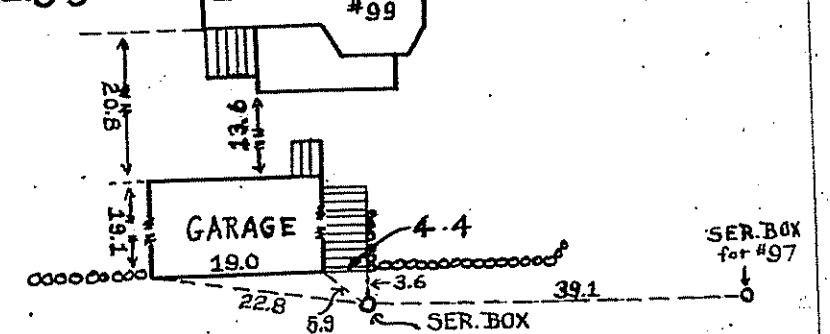

6" H.S.

BOW ST.

1"=20'

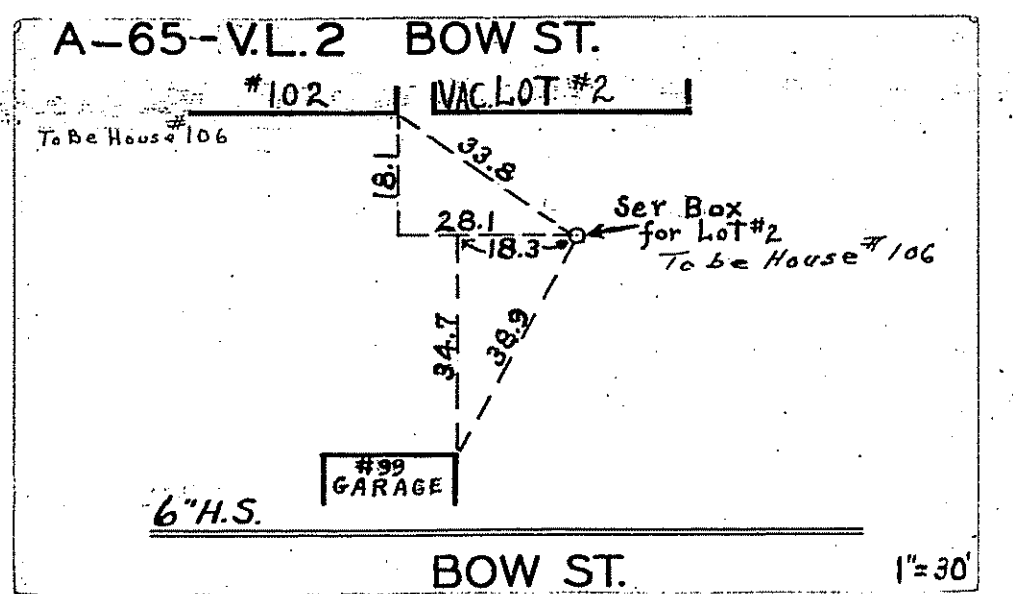
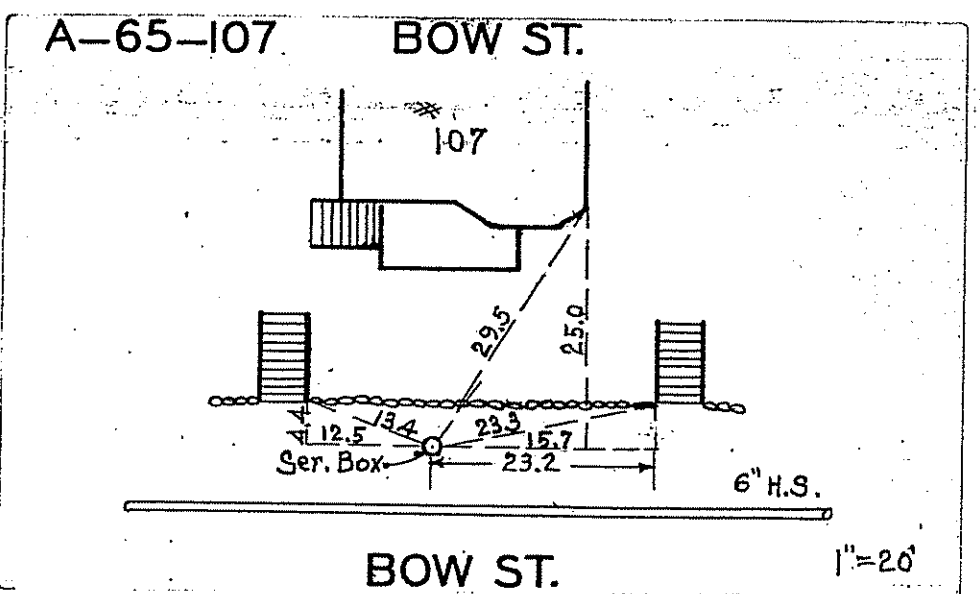
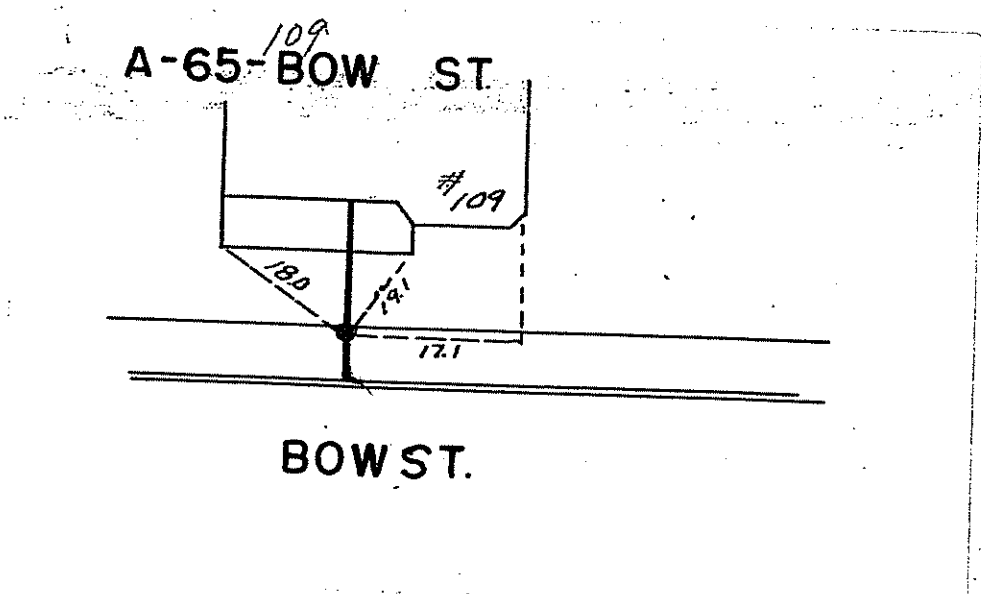
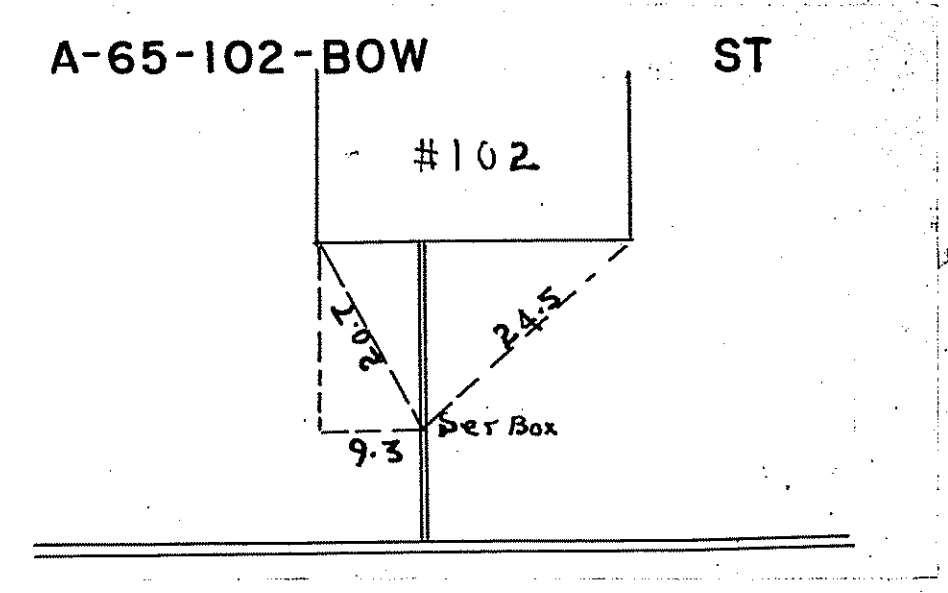
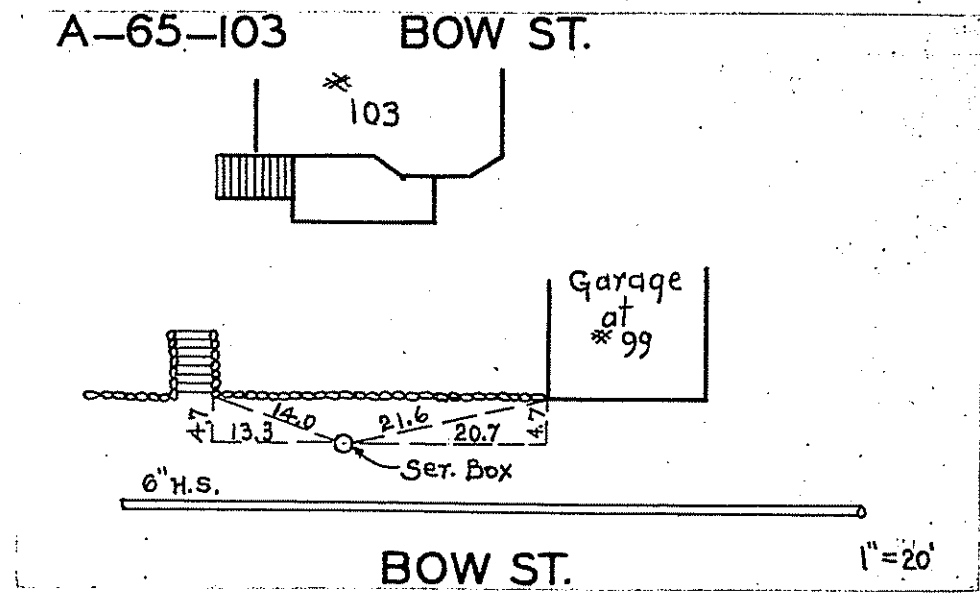
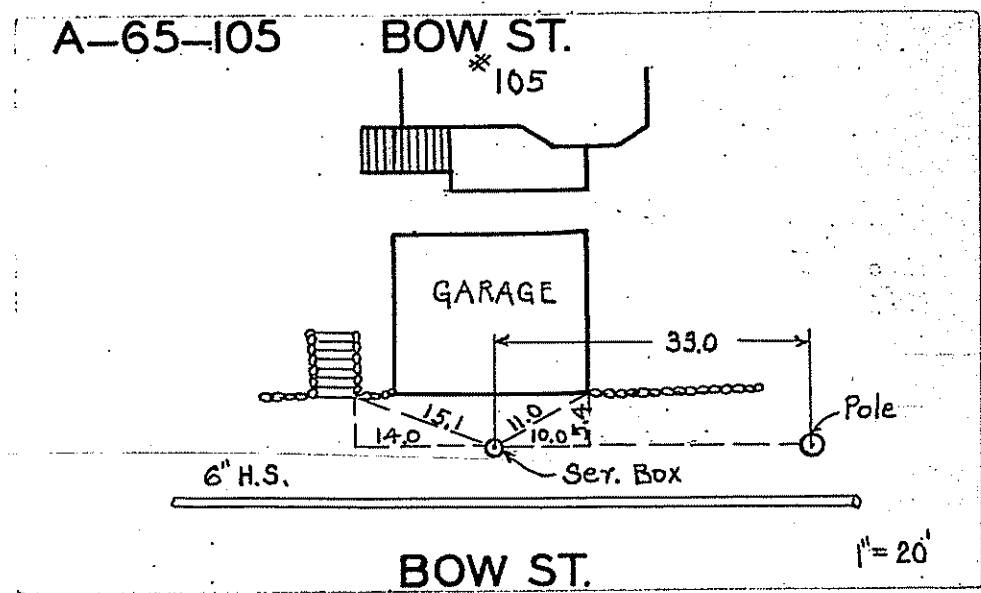

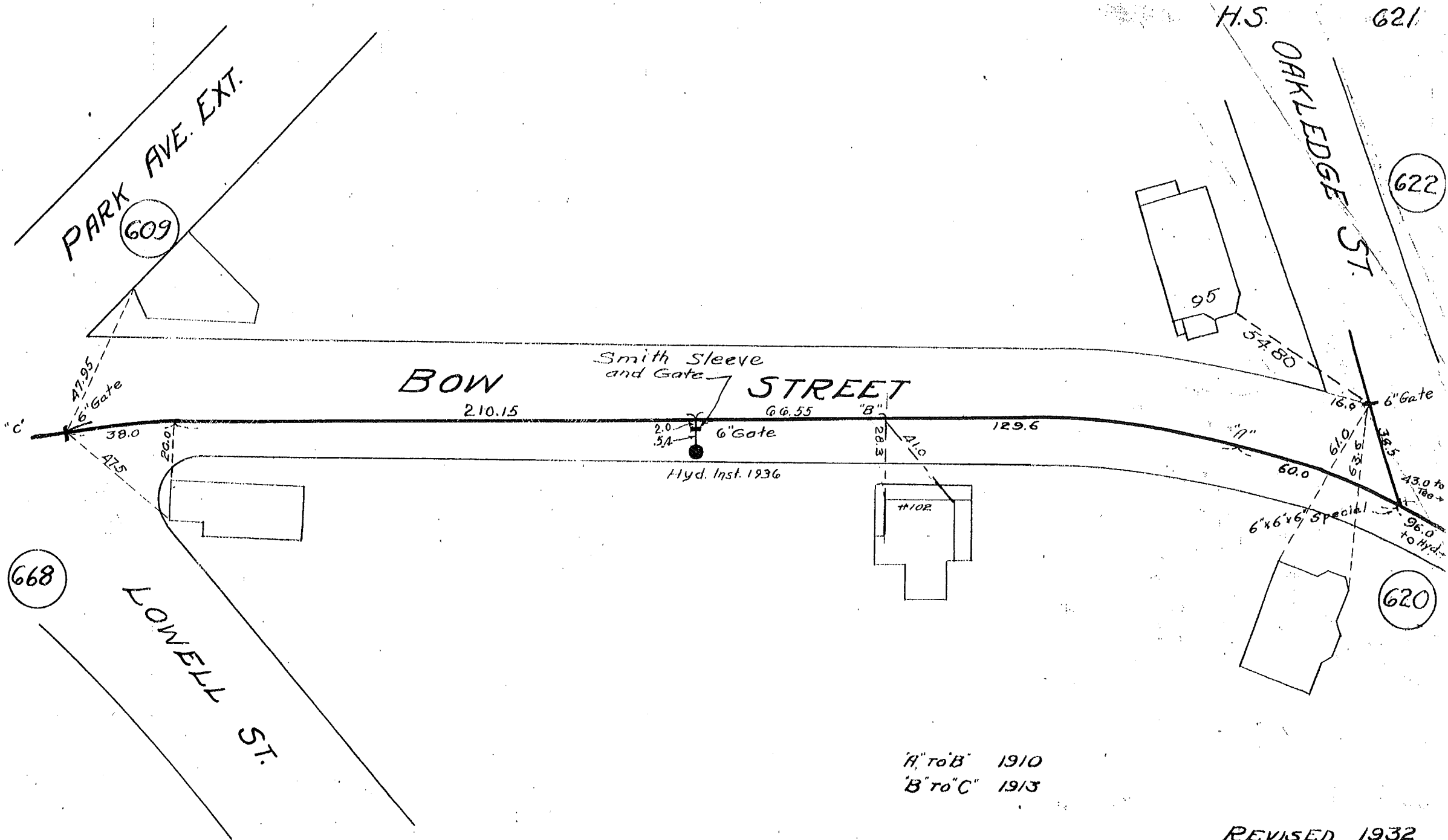

668

609

622

620

621

H. to B. 1910
 B. to C. 1913

REVISED 1932

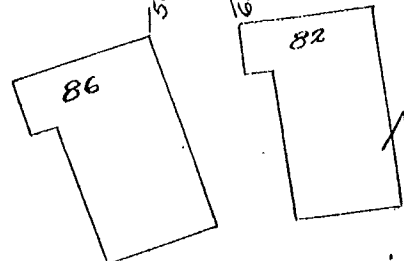
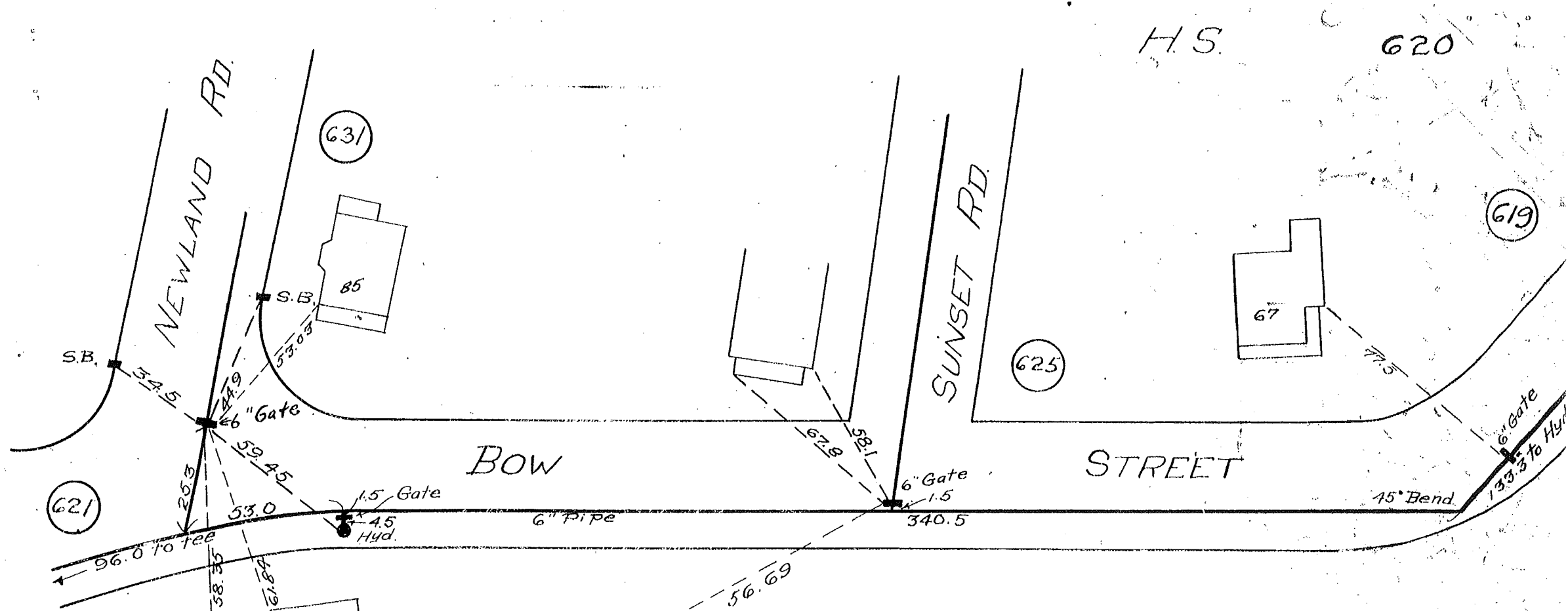

Note:

Revised 1926
 Note: New Hyd. & Gate Set 1930

1904
 REVISED IN 1930

619

H.S.

623

618

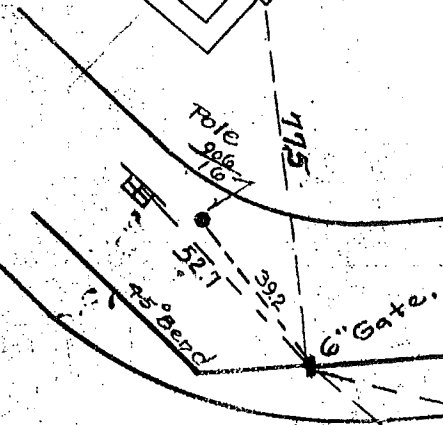
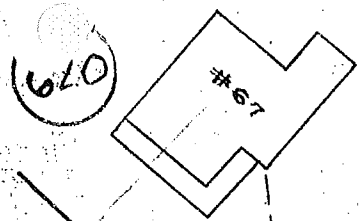

BOW

156.1

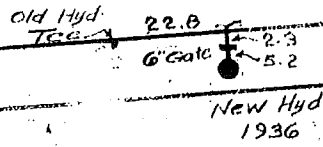

426.9

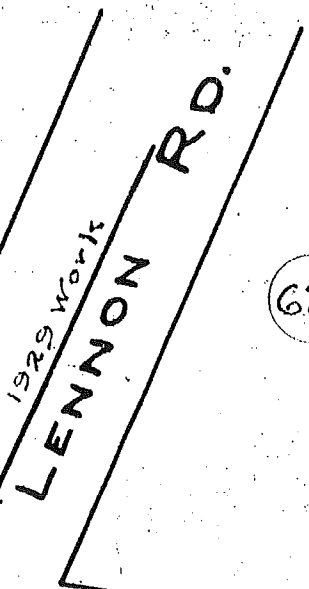

ST.

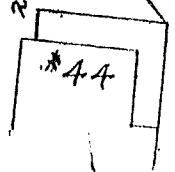
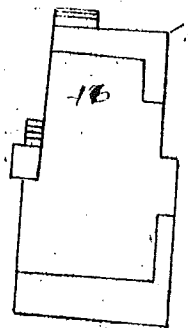
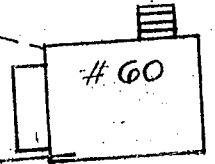

Note - Revised 1926

1902
REVISED IN 1932

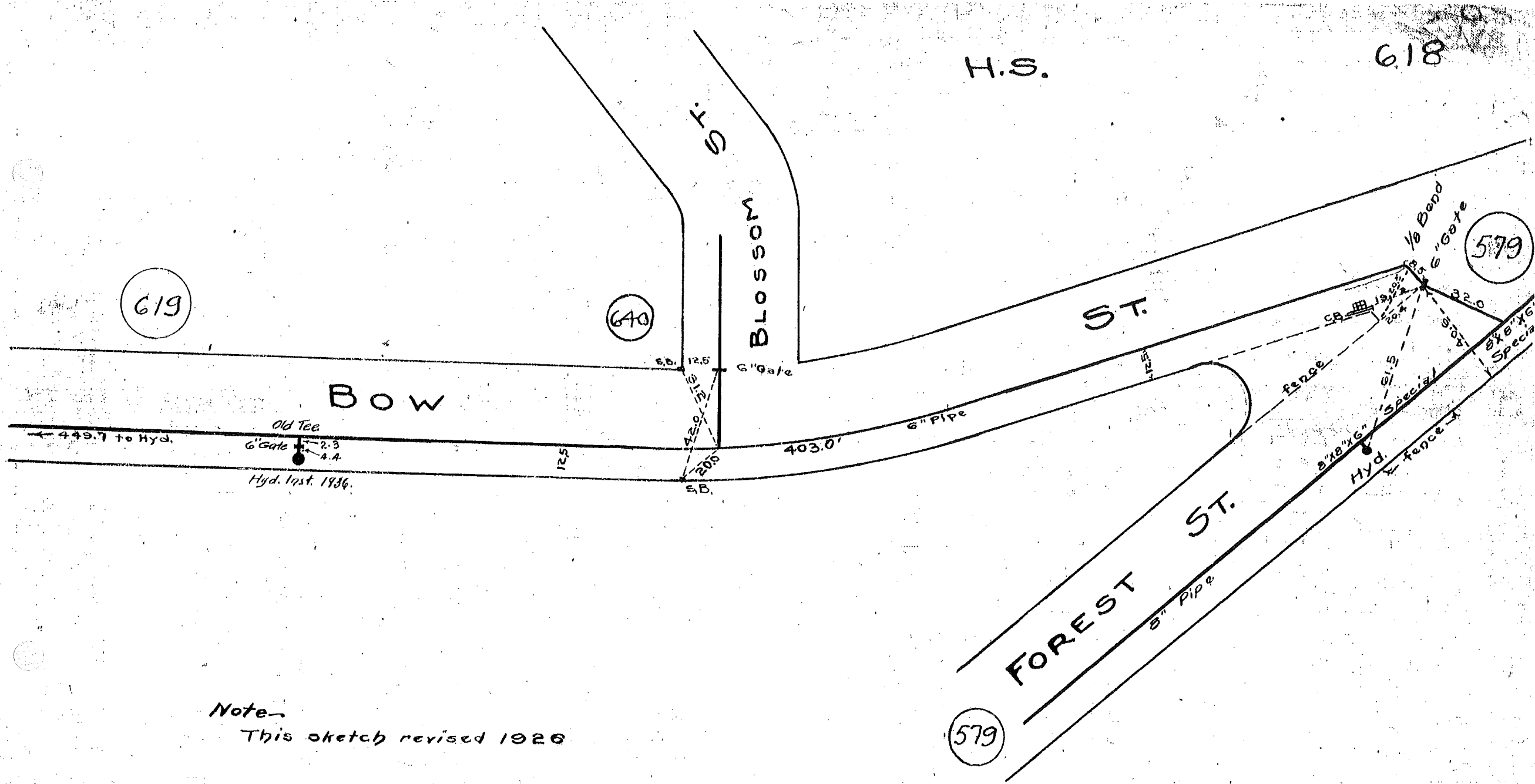

619

640

579

579

Note
This sketch revised 1926

1902

H. S.

610

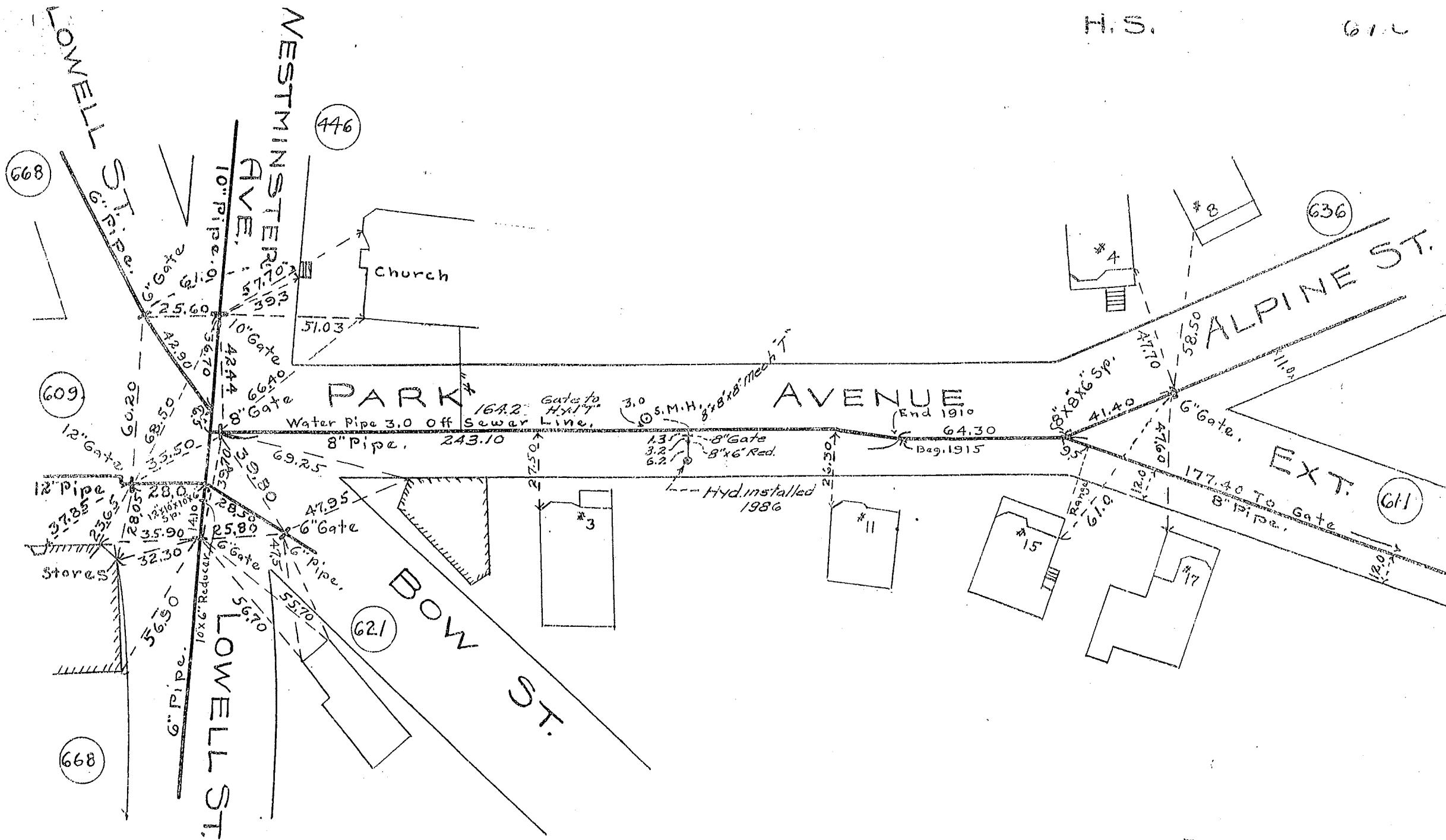

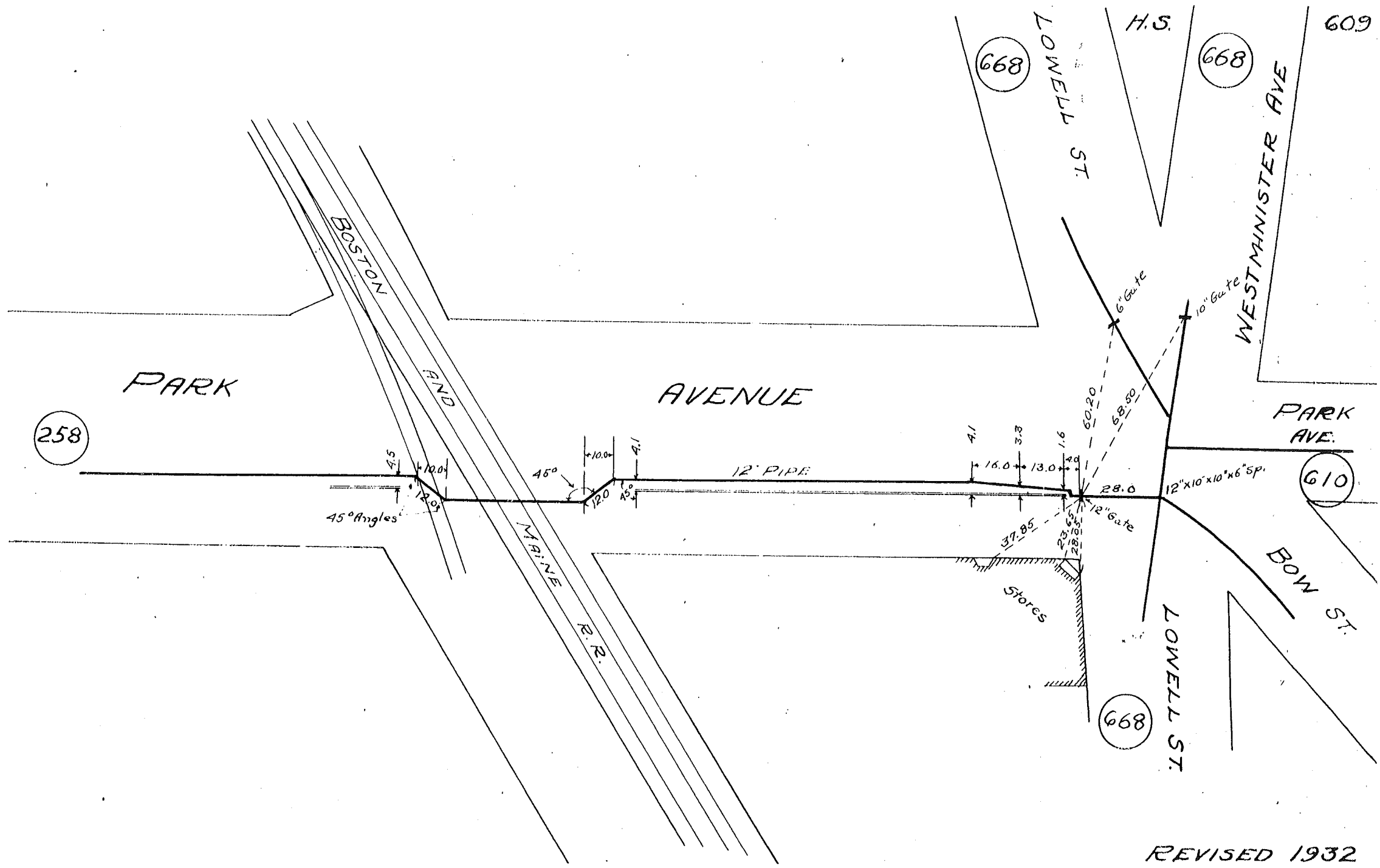

REVISED 1932

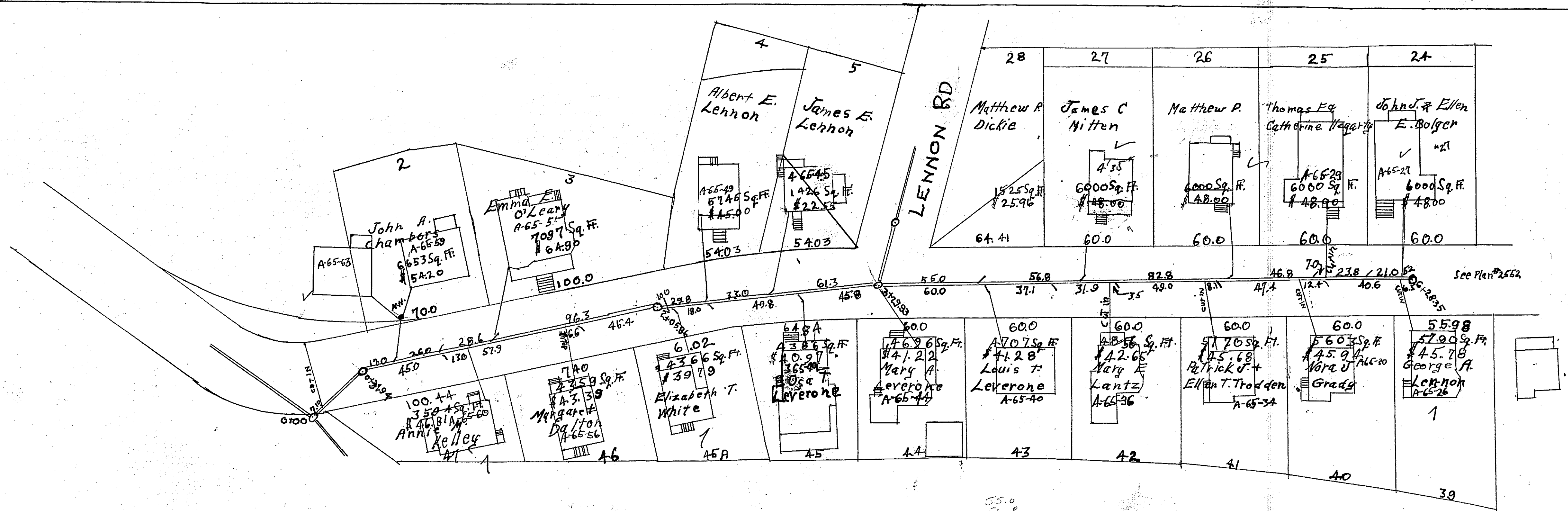

- 55.0
- 56.8
- 82.8
- 46.8
- 7.0
- 23.8
- 21.0

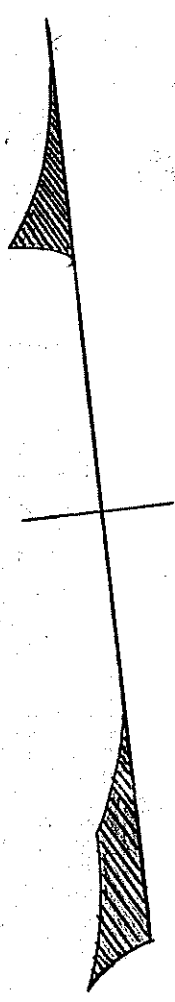

SEWER ASSESSMENT PLAN
 No. 486
 BOW STREET
 Scales: Hor. 1"=40'
 Vert. 1"=6'
 July 29, 1929
 J.M. Keane Town Engineer

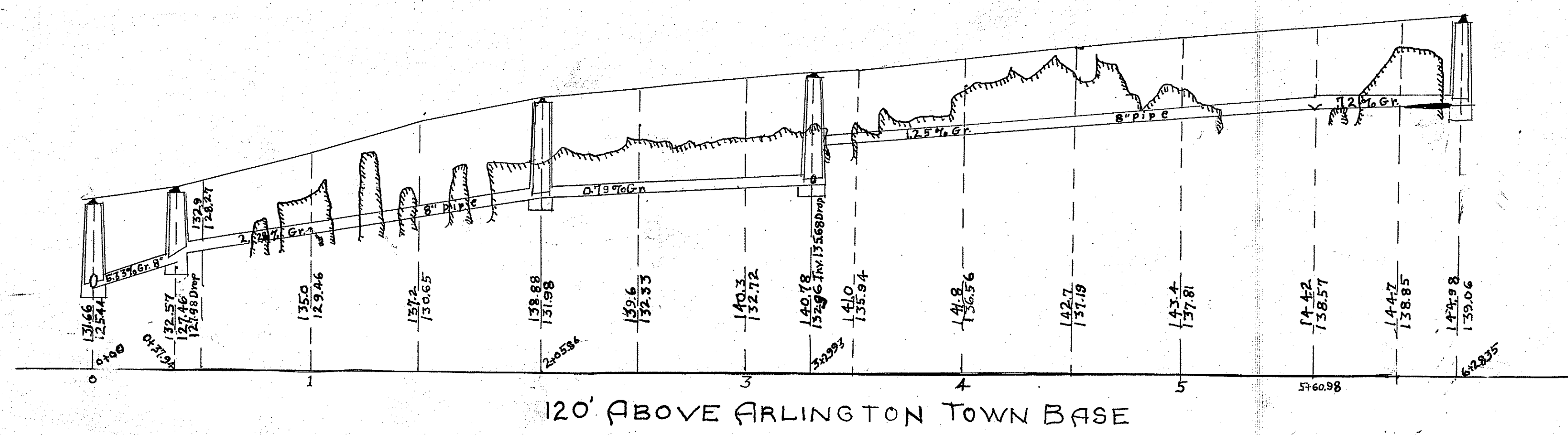

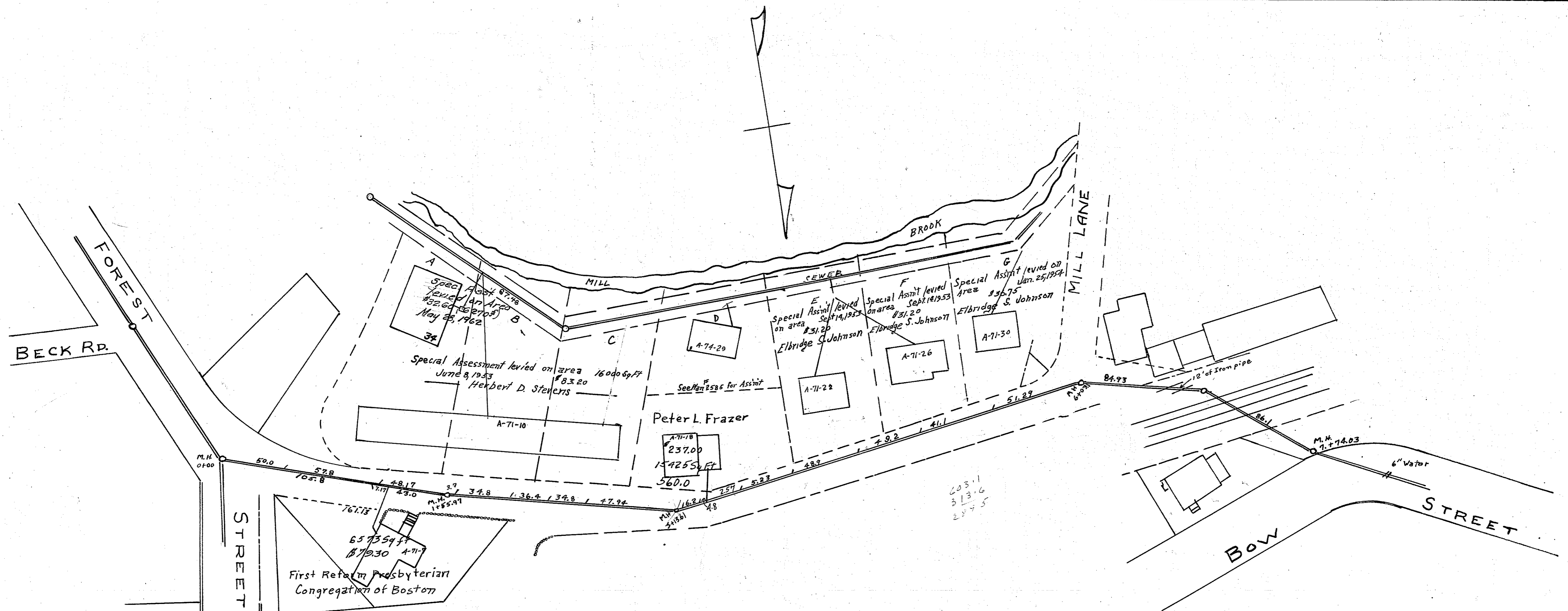

First Reform Presbyterian
Congregation of Boston

Peter L. Frazer

SEWER ASSESSMENT PLAN
No. 467
BOW ST. OUTLET SEWER
THROUGH LAND OF B. & M. R.R. &
FOREST STREET PLACE
Scales: Hor. 1" = 40'
Vert. 1" = 6'
Dec. 21, 1928
J.M. Keane Town Engineer

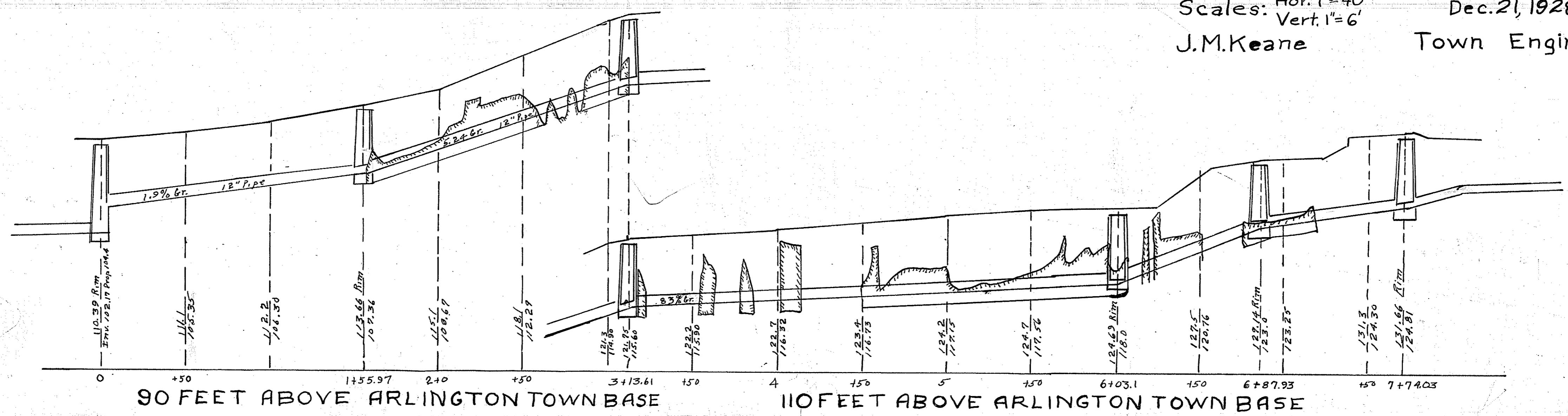

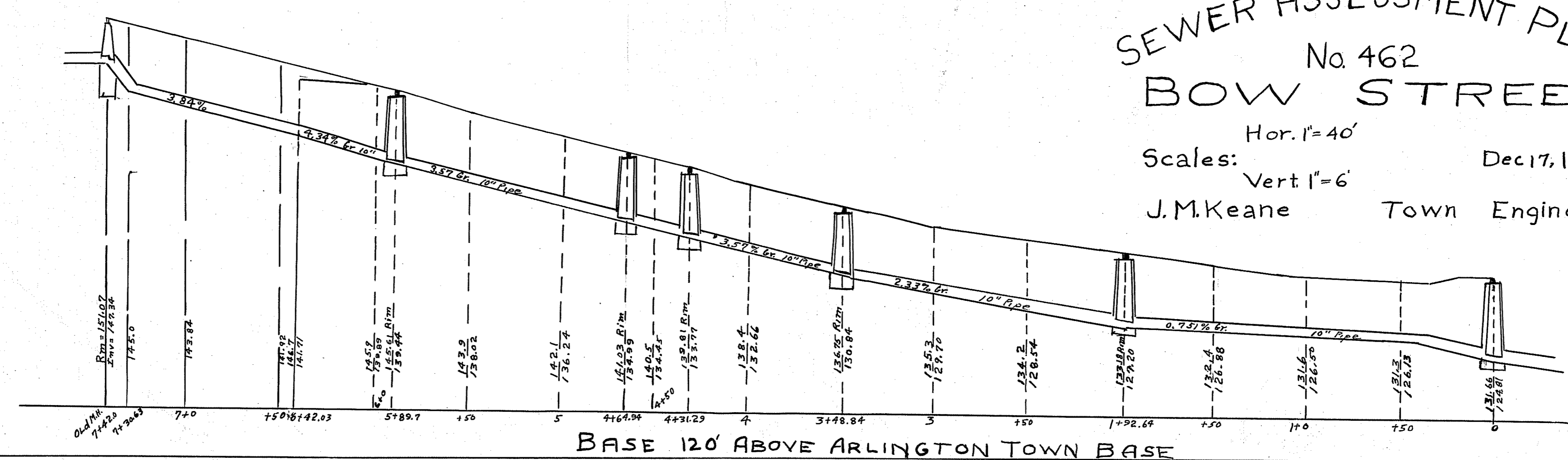
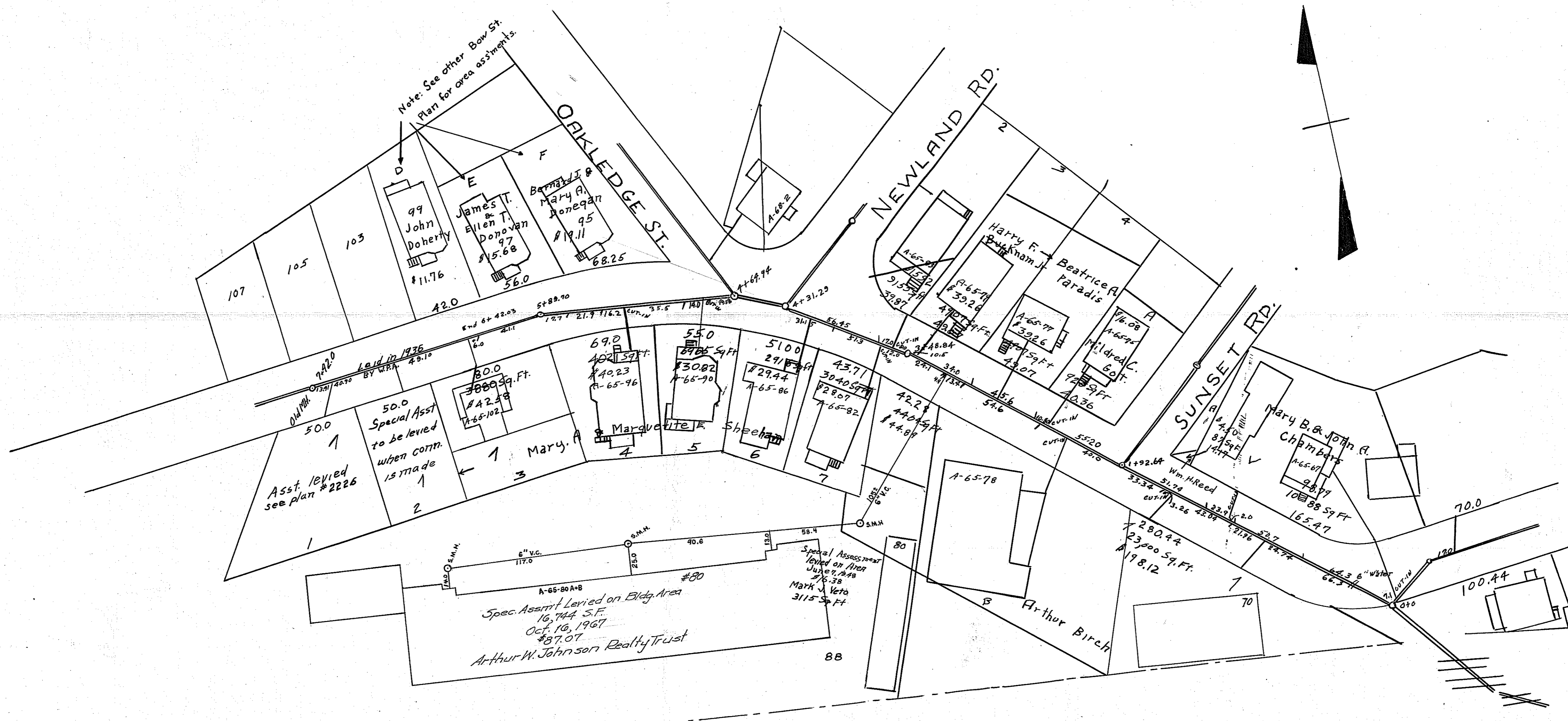

SEWER ASSESSMENT PLAN
 No. 462
 BOW STREET
 Hor. 1" = 40'
 Scales: Vert. 1" = 6'
 J.M. Keane Town Engineer
 Dec 17, 1928

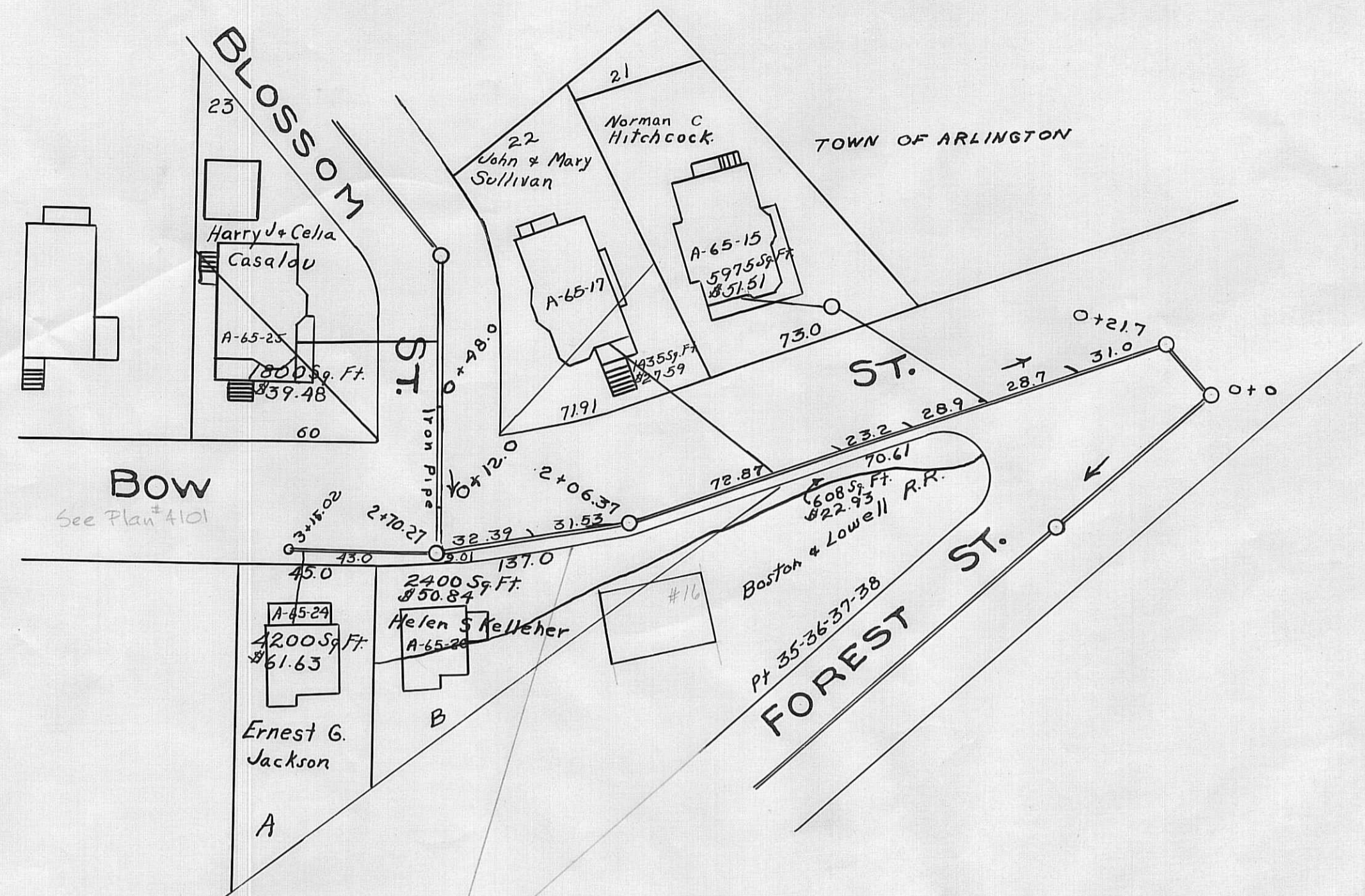

SEWER ASSESSMENT PLAN
 No. 354
 BOW STREET
 SCALES { HOR 1" = 40'
 VER 1" = 6'
 GEO. E. AHERN TOWN ENGINEER
 MARCH 11, 1924.
 Assessment levied in 1927
 Note:- From Sta. 2+70.27 to sta. 3+15.02 built in 1941

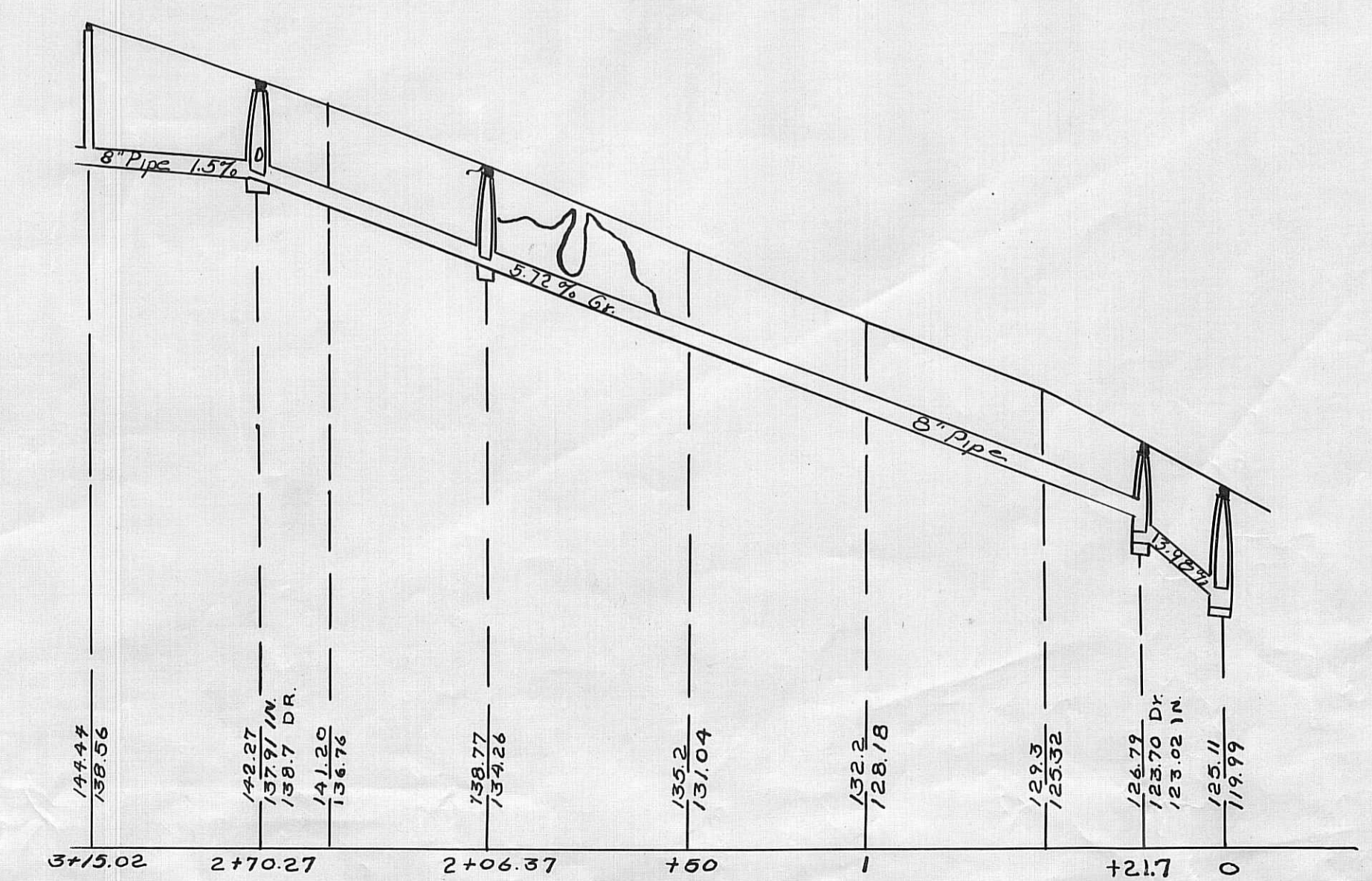
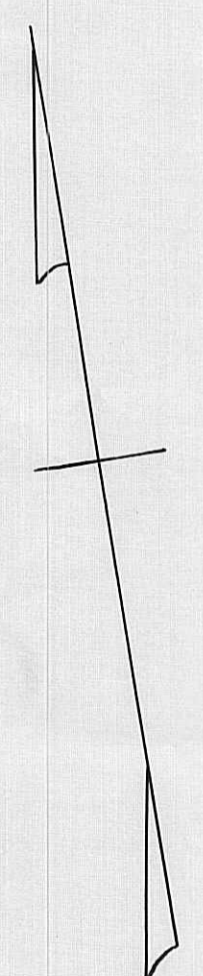

BASE 110' ABOVE ARLINGTON TOWN BASE.

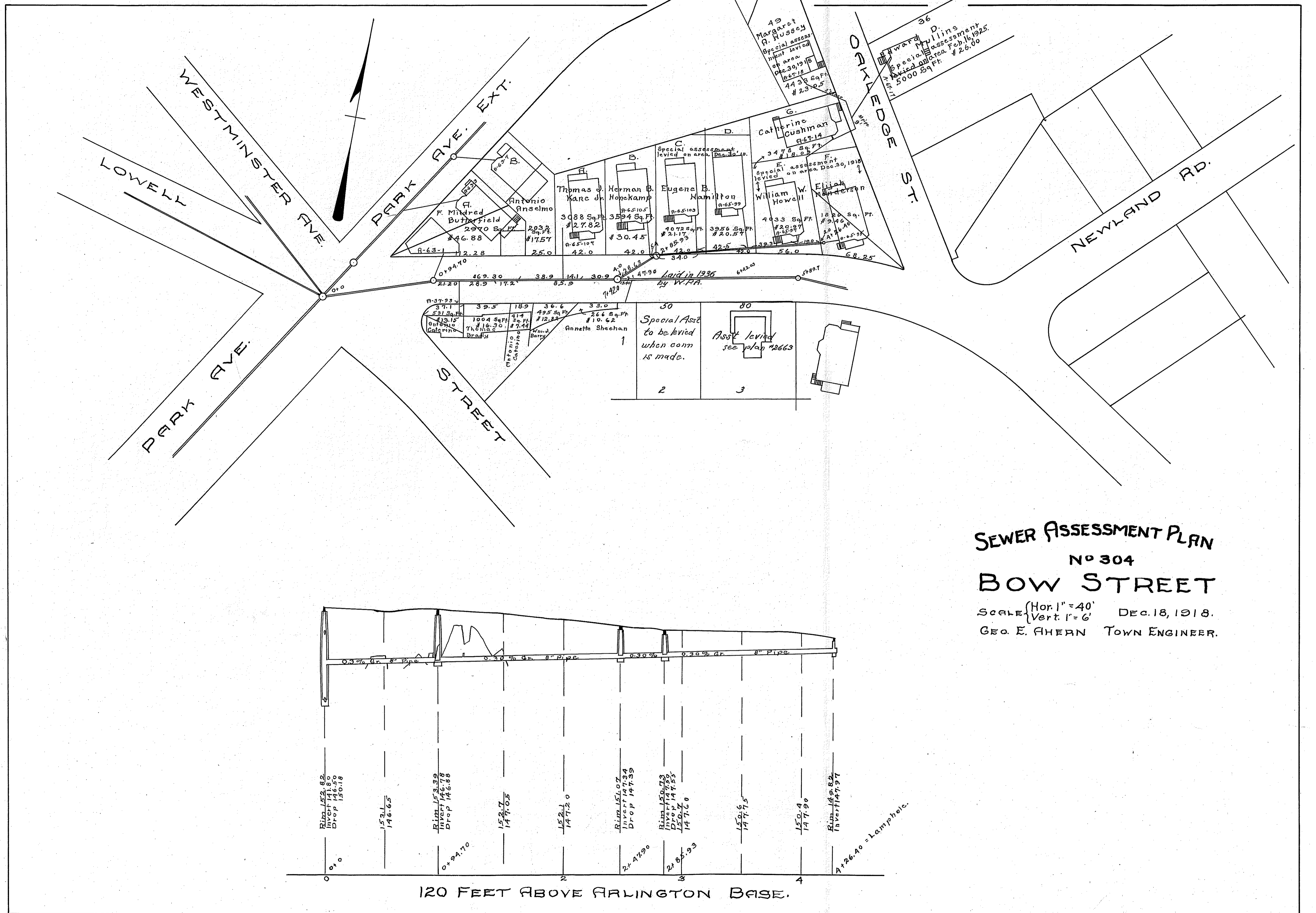

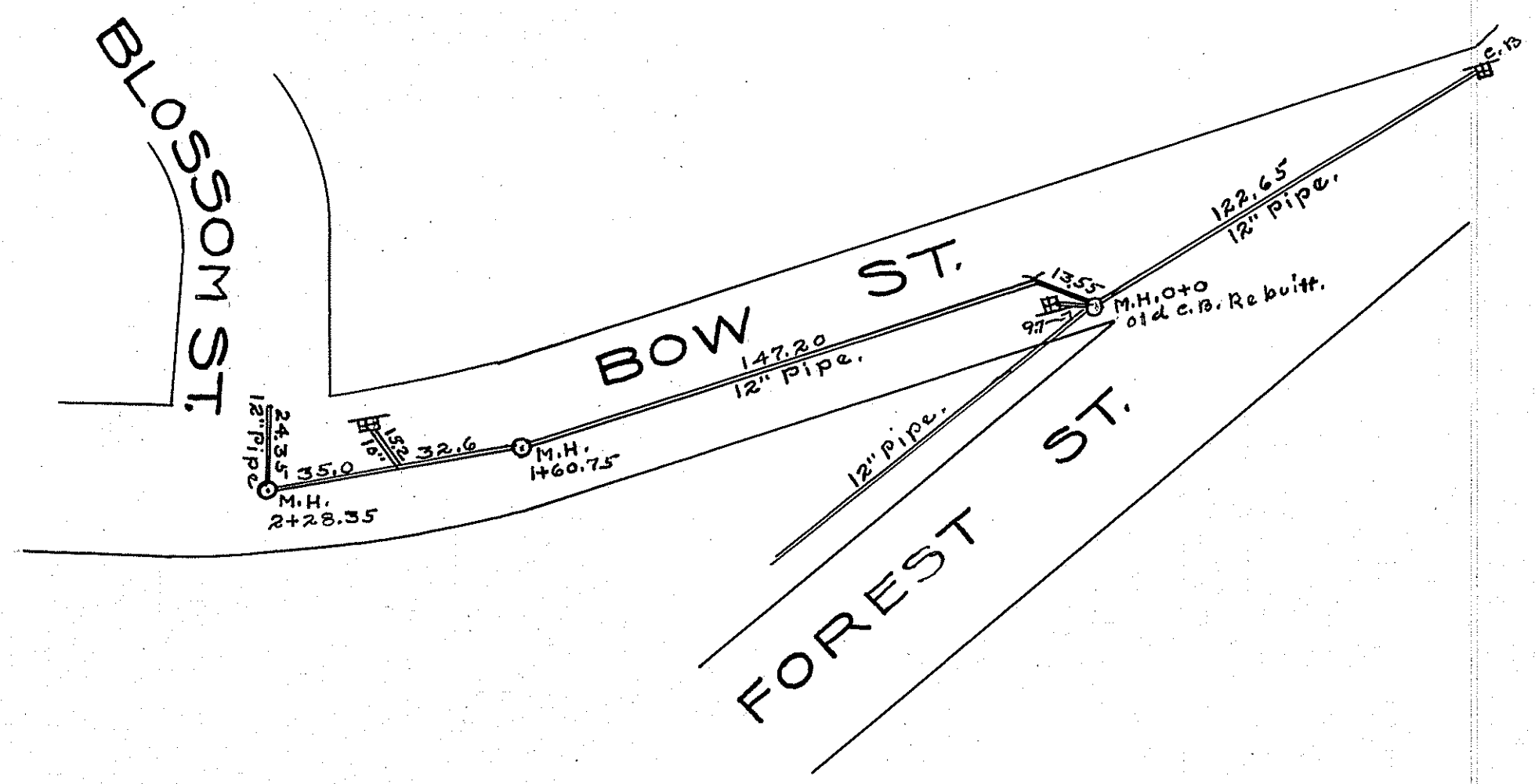
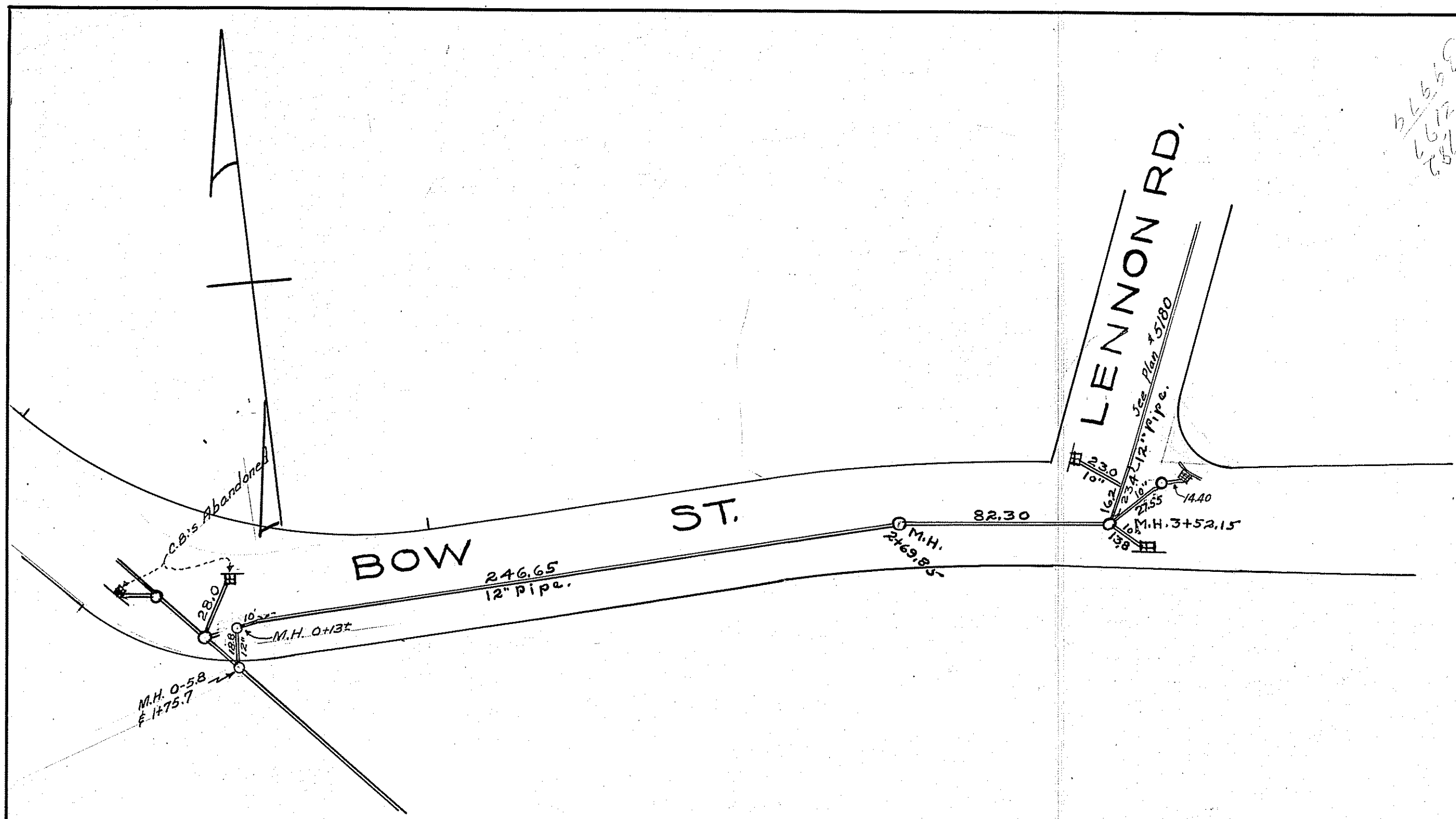

NOTE:
See PL # 1893 for more detail

PLAN AND PROFILE
OF
STORM DRAIN
IN
BOW STREET
SCALES } VERT. 1" = 6'
 } HOR. 1" = 40' JAN. 27, 1936.
 JAMES M. KEANE, TOWN ENGINEER.

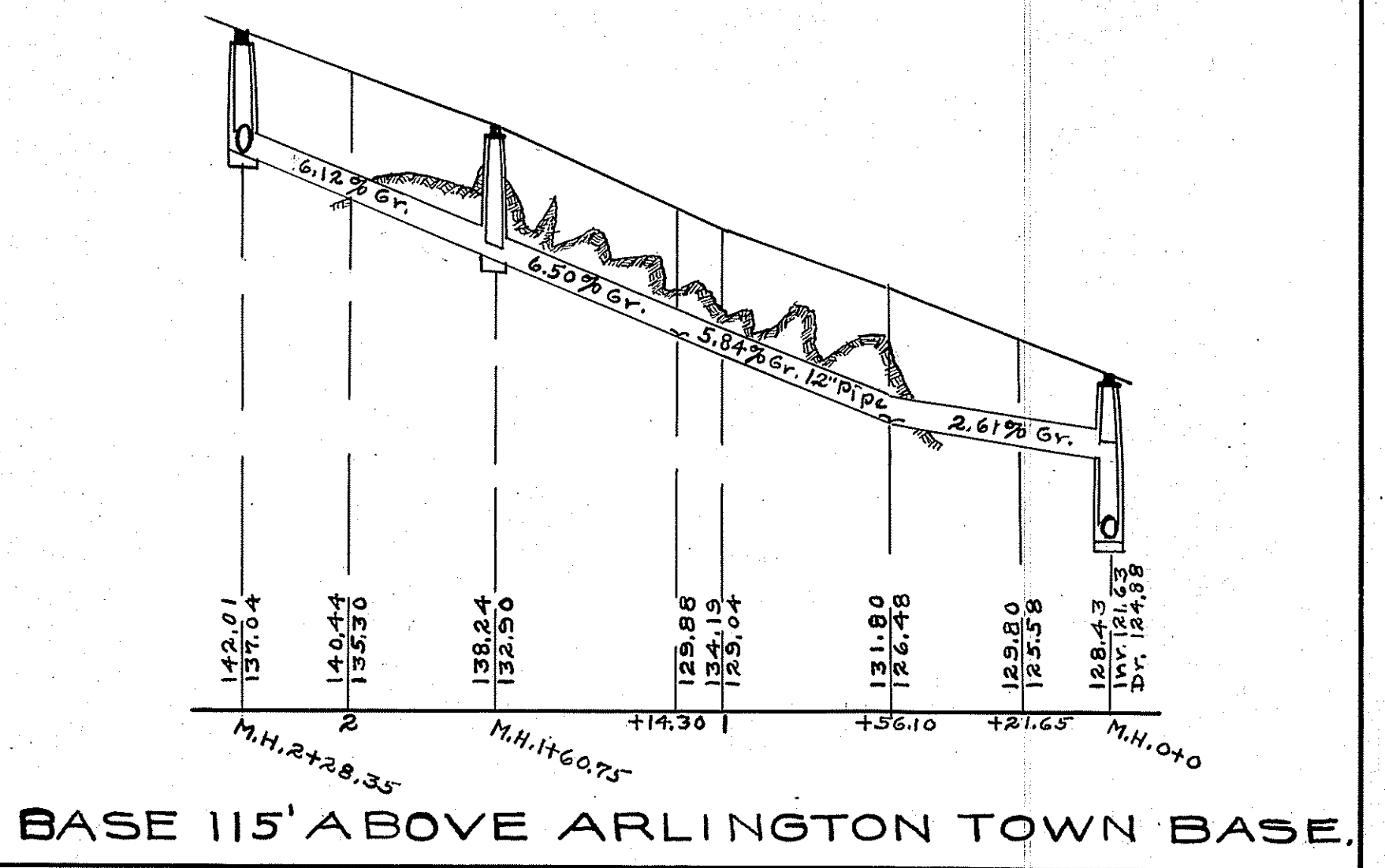
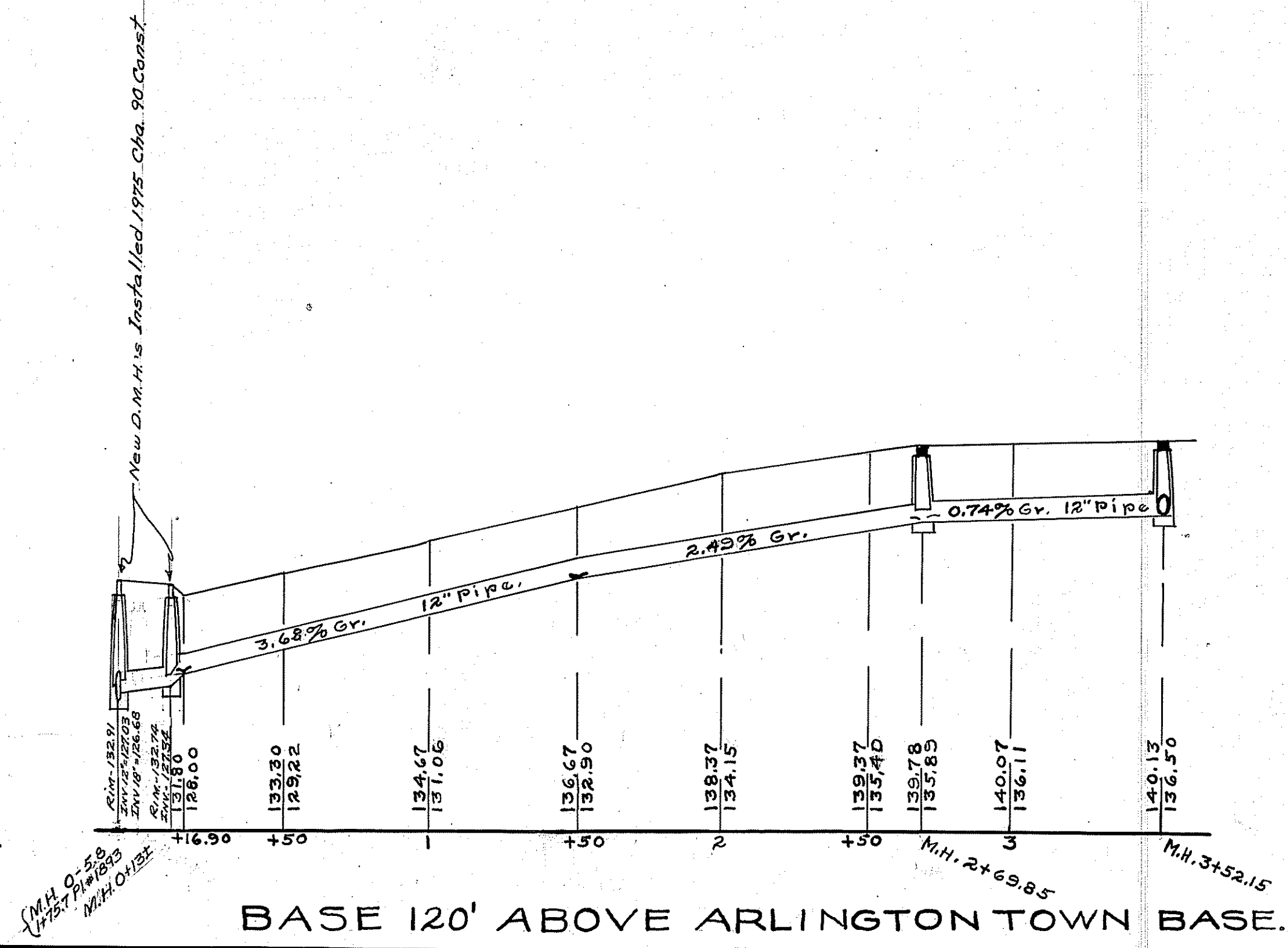

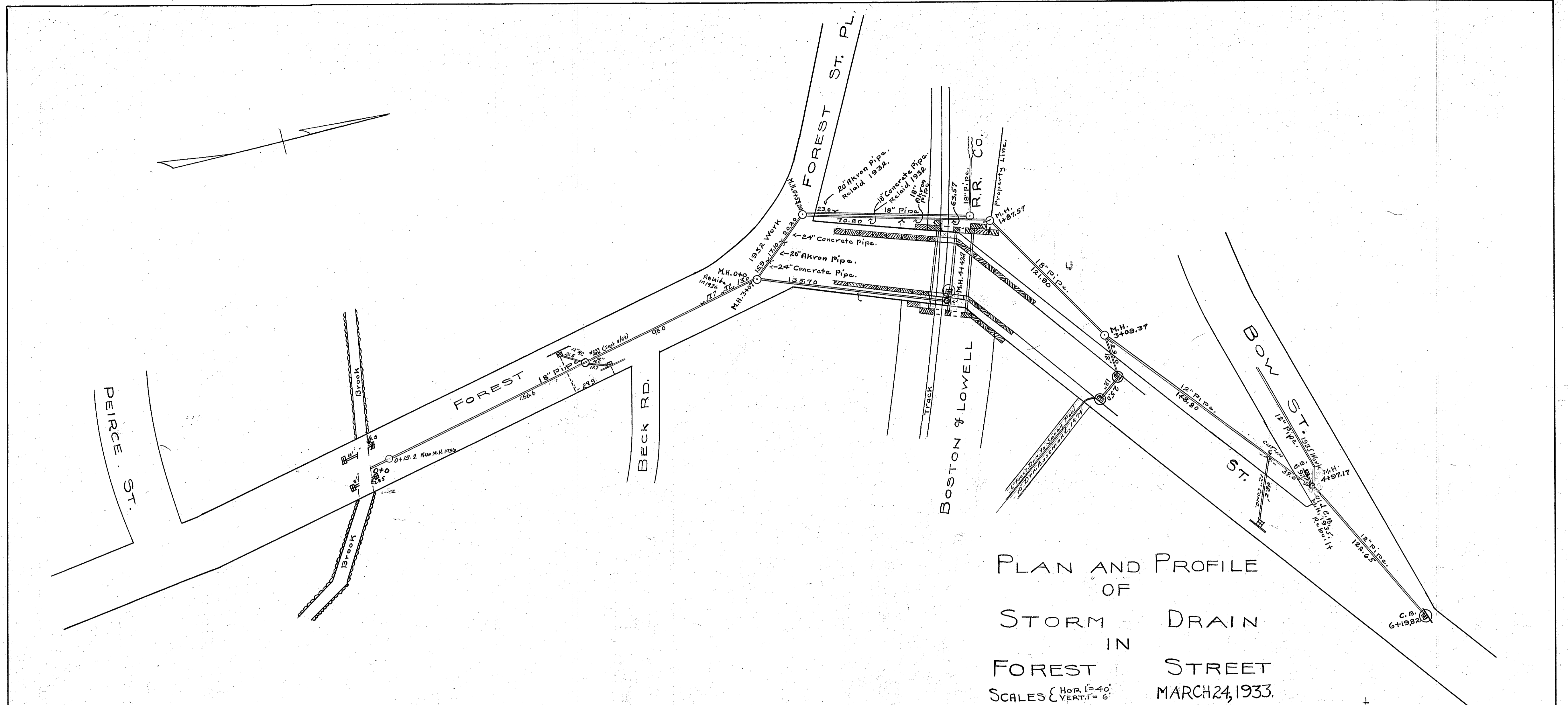

PLAN AND PROFILE
OF
STORM DRAIN
IN
FOREST STREET
MARCH 24, 1933.
JAMES M. KEANE, TOWN ENGINEER.

Note: Data from Plan 016.
Sta. 0+0 to 3+07 Laid in 1936

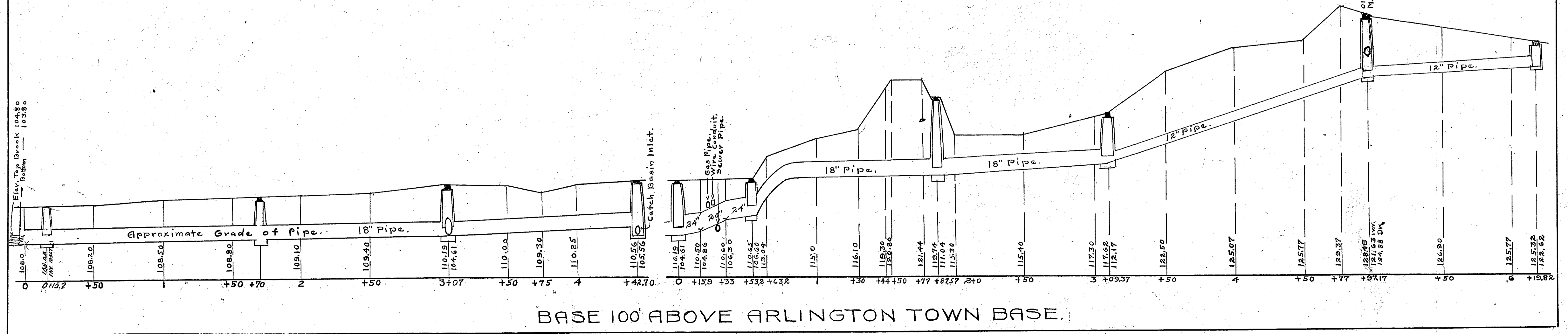

BASE 100' ABOVE ARLINGTON TOWN BASE.

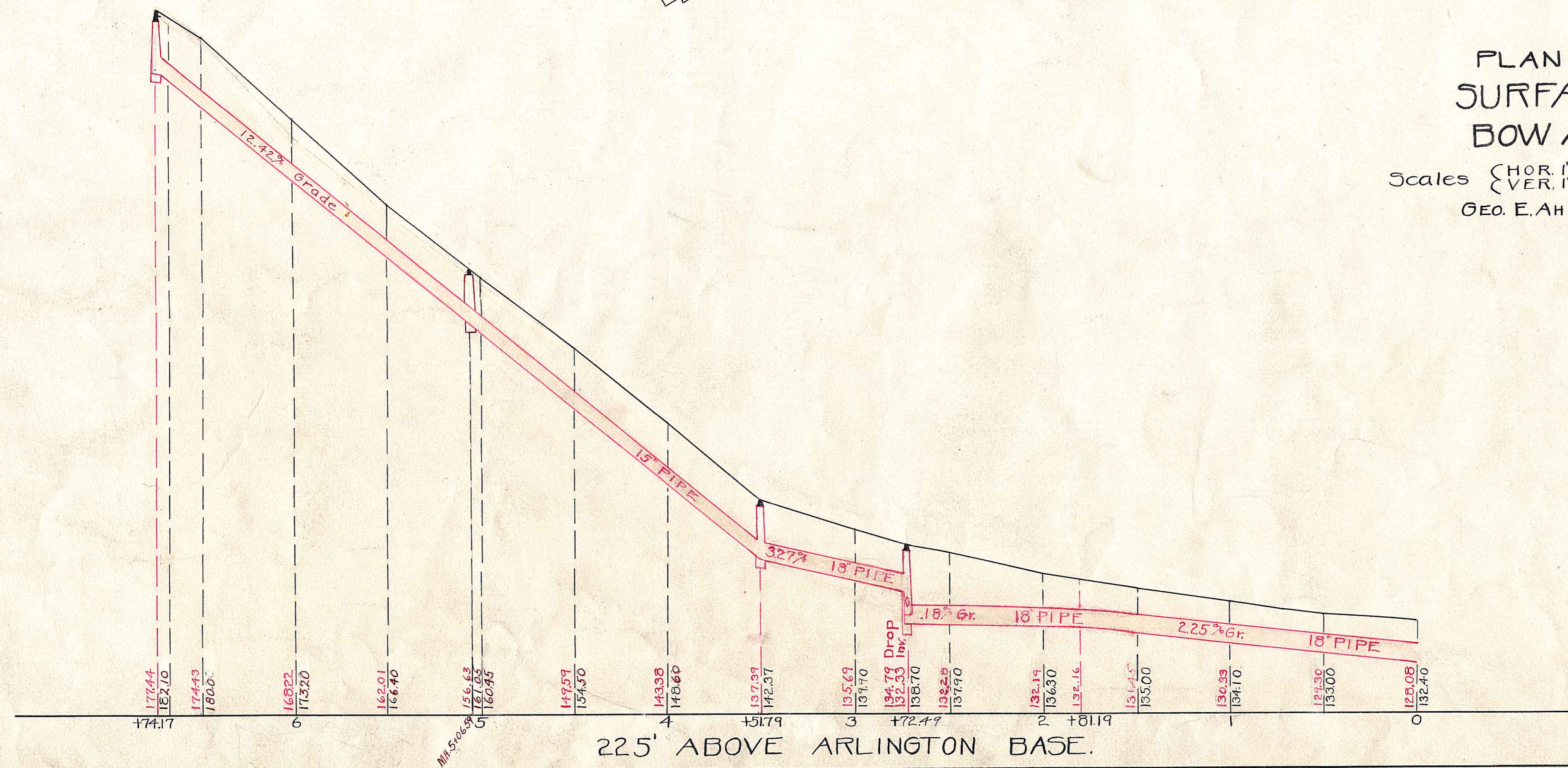
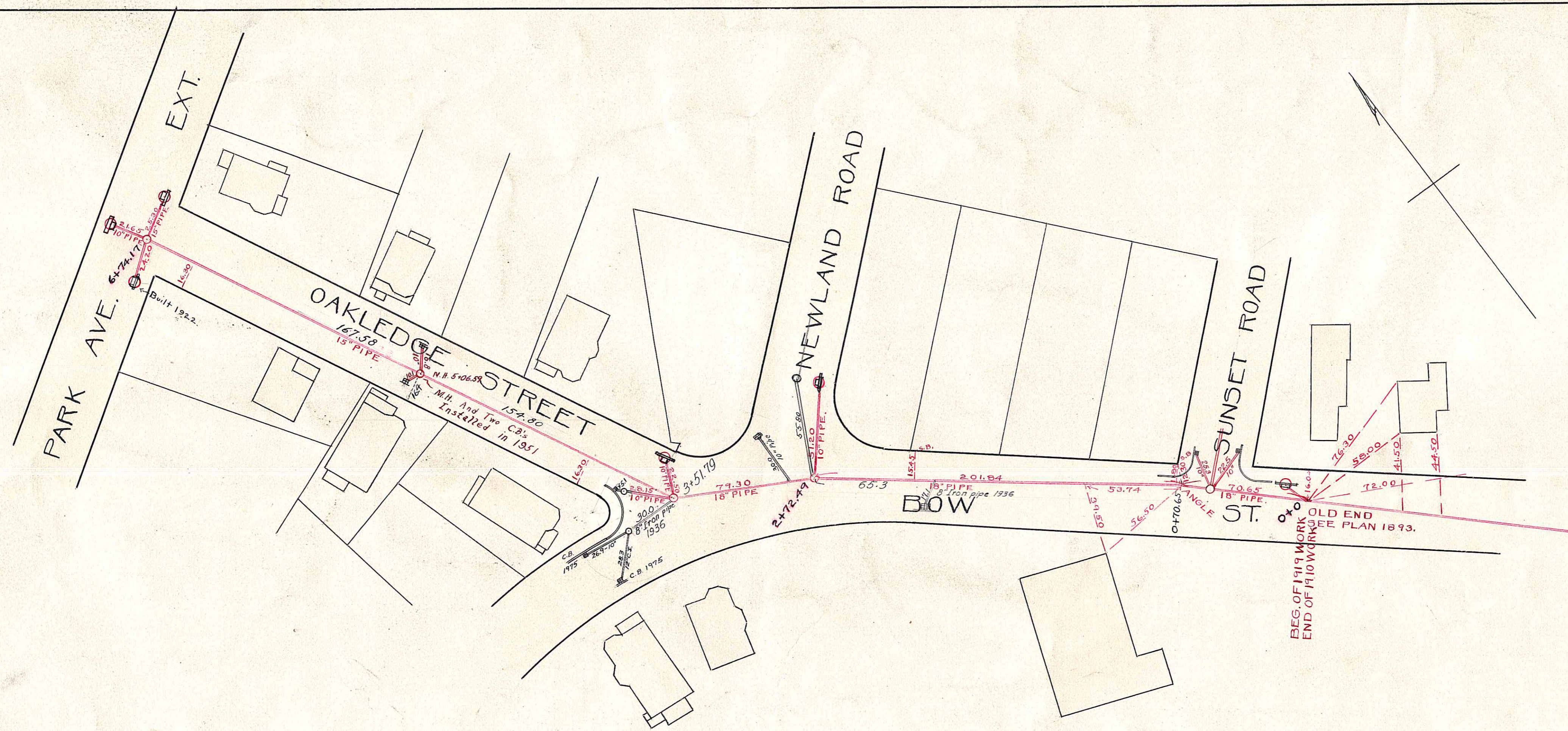

PLAN AND PROFILE OF
SURFACE DRAIN
BOW AND OAKLEDGE ST.

Scales { HOR. 1"=40'
VER. 1"=6'
GEO. E. AHERN.

NOV. 3, 1919.
TOWN ENGINEER.

225' ABOVE ARLINGTON BASE.

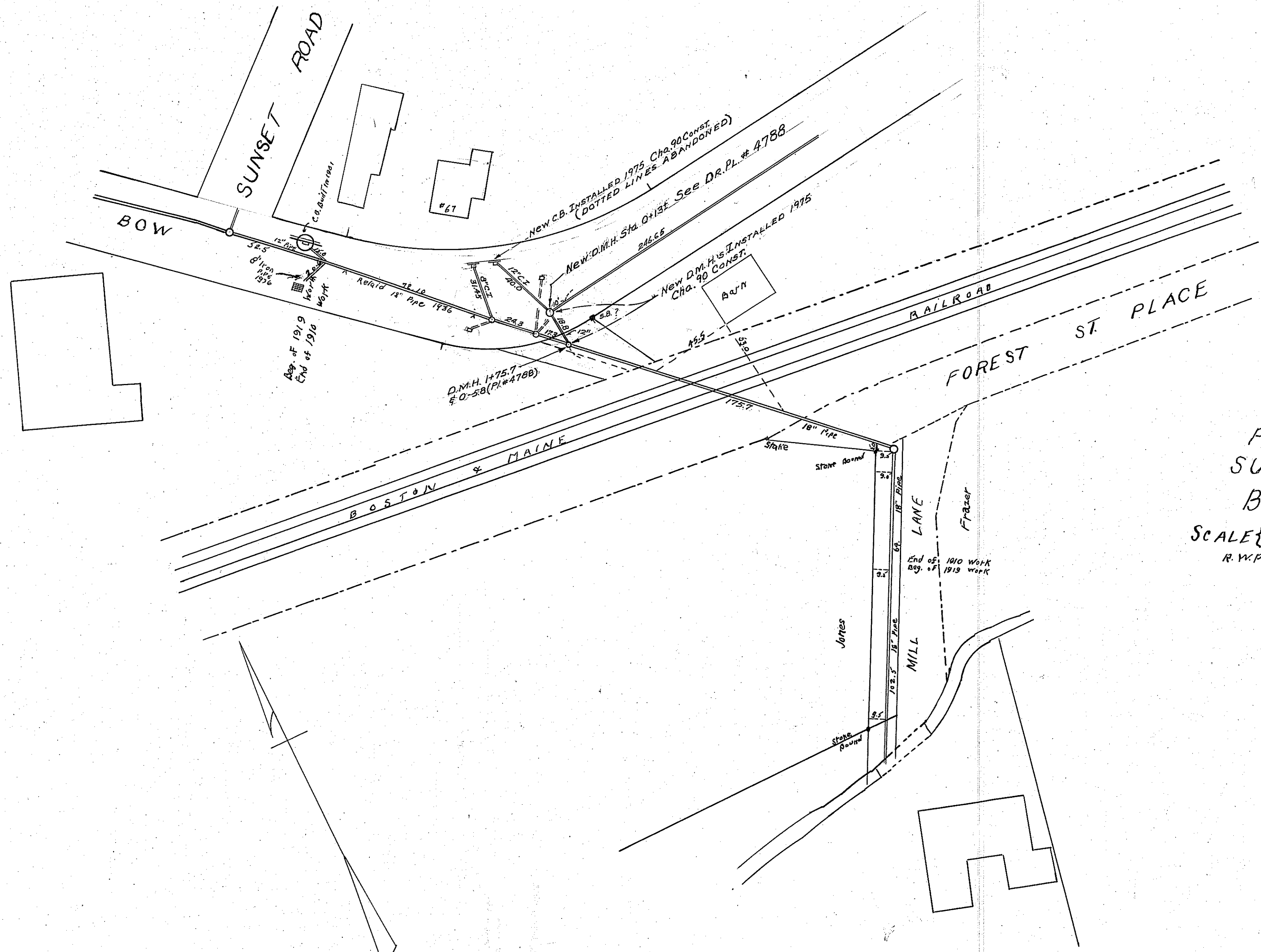

PLAN and PROFILE
 SURFACE - DRAIN
 BOW STREET.
 SCALE { Hor. 1"=40'
 Ver. 1"=6'
 JAN. 25, 1910
 R. W. POND ~ TOWN ENGINEER

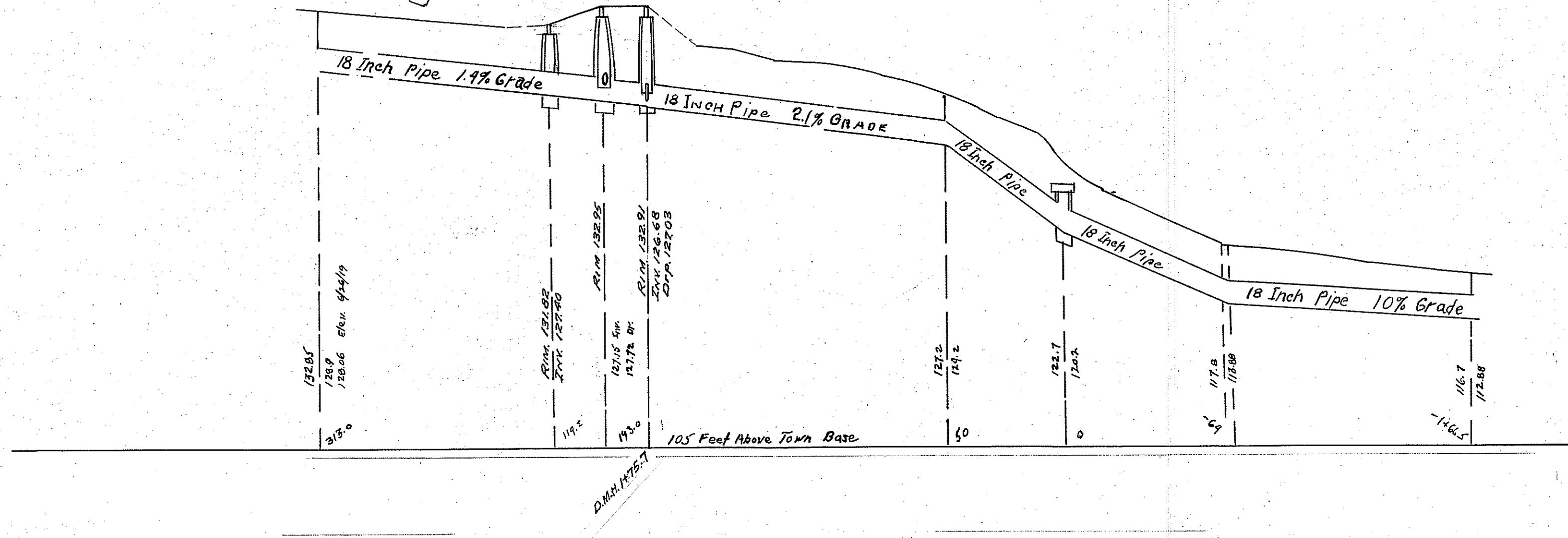

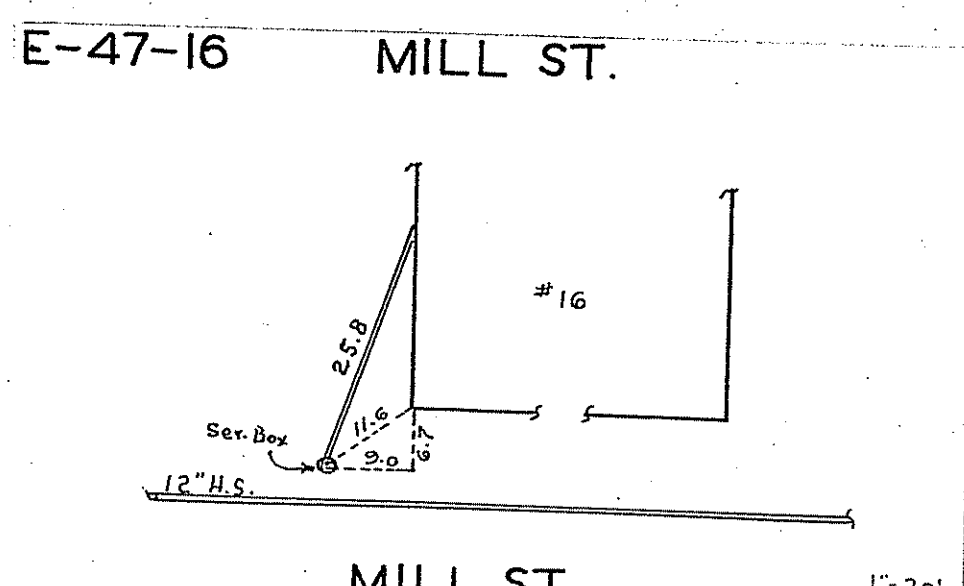
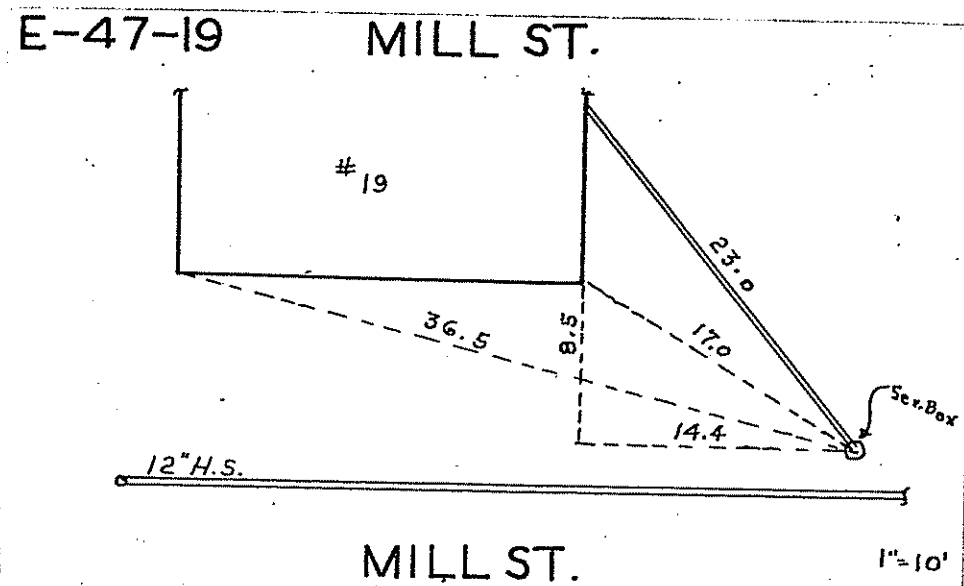
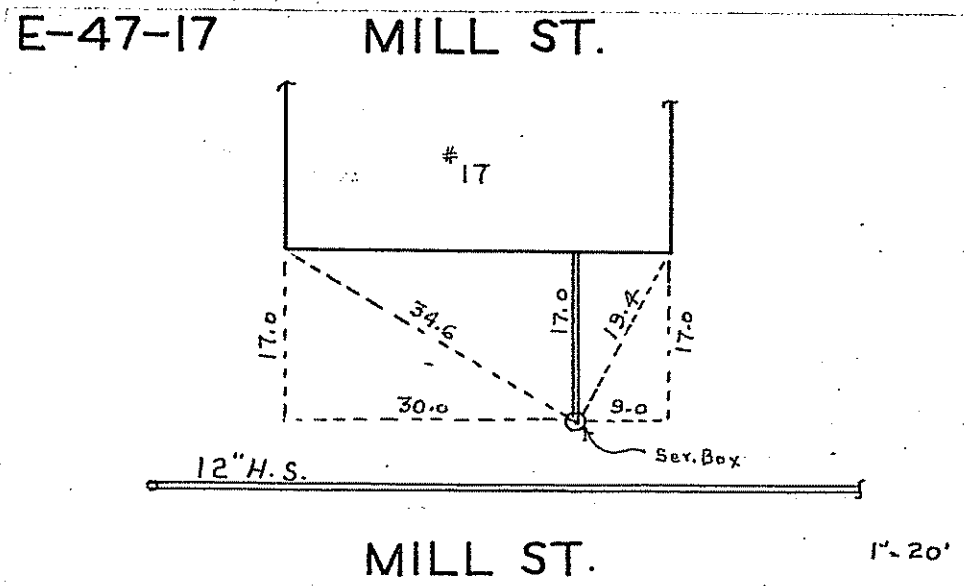
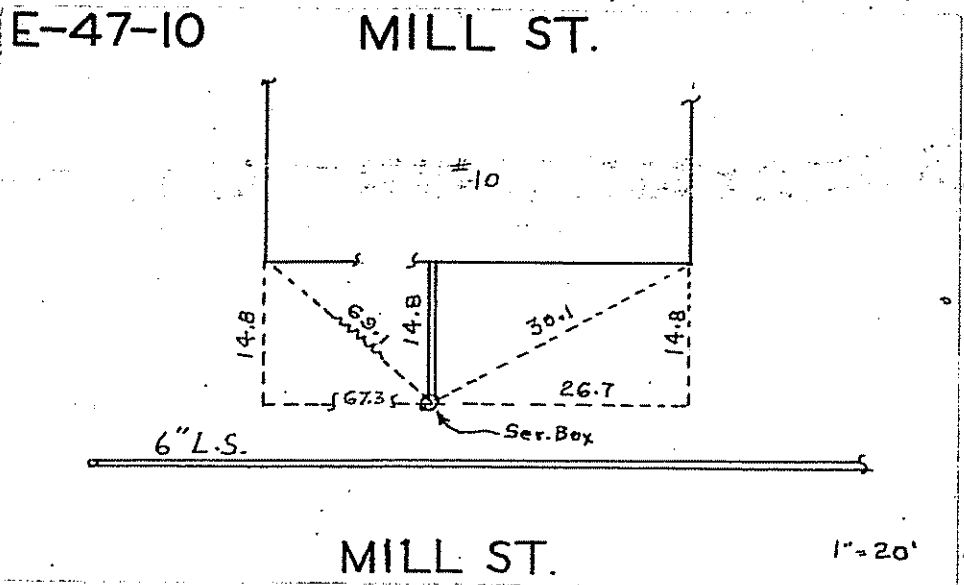
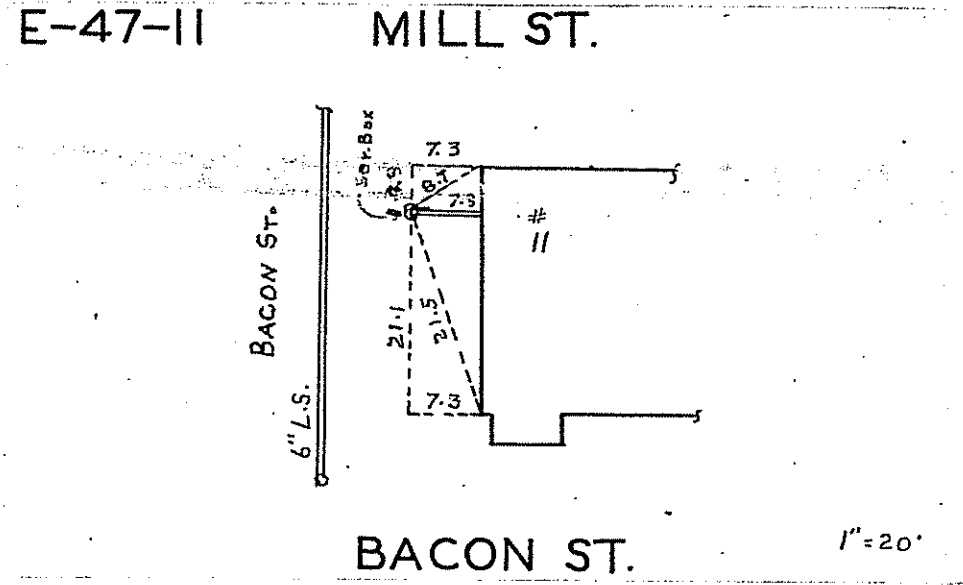
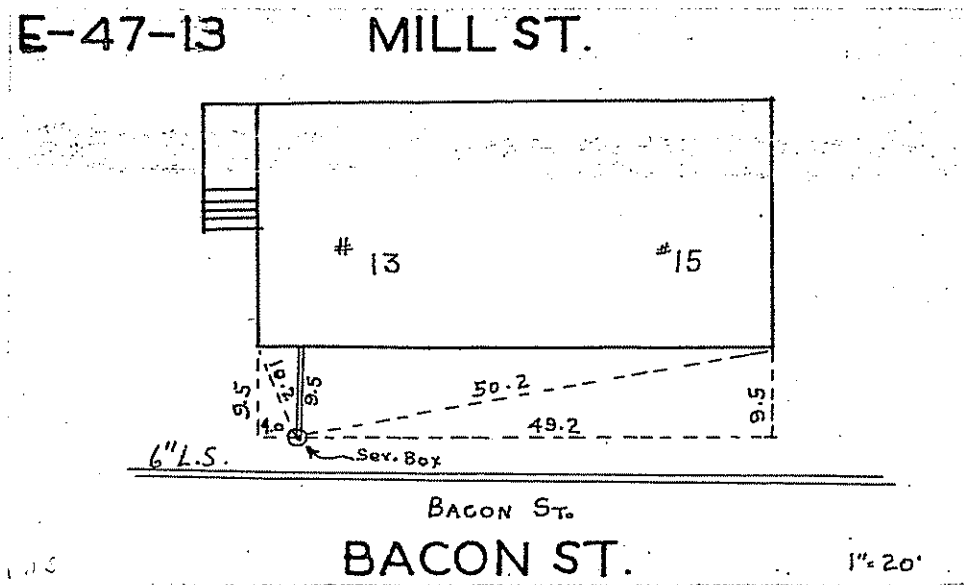
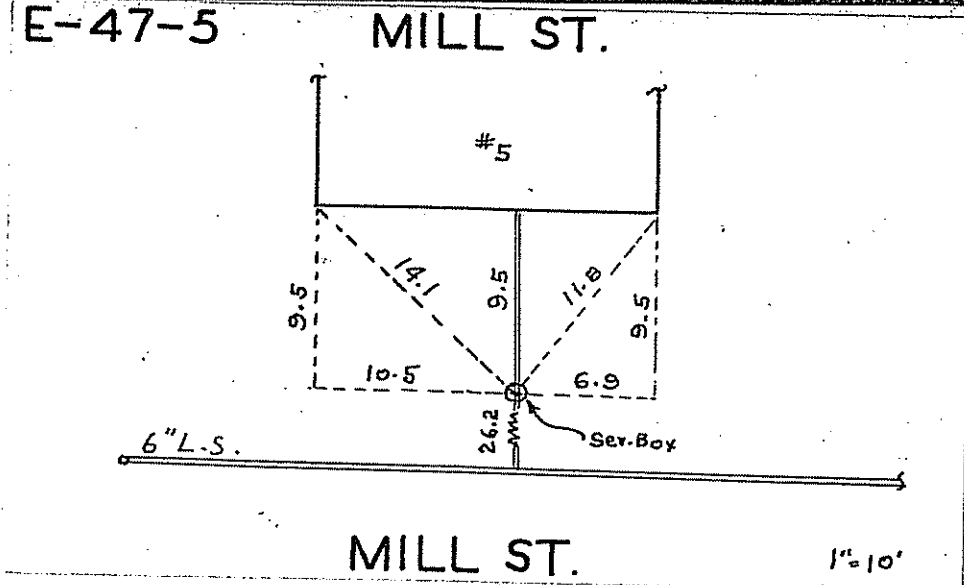
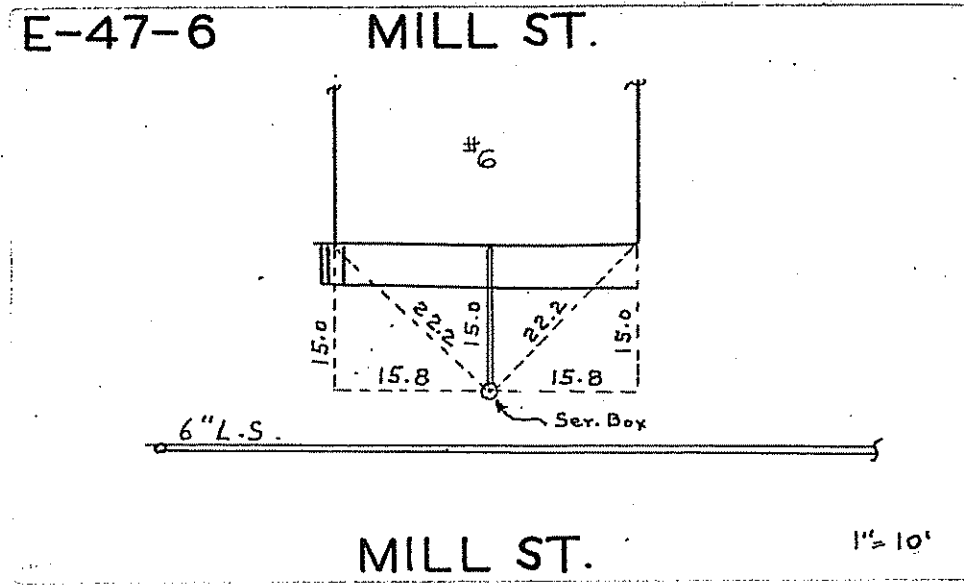
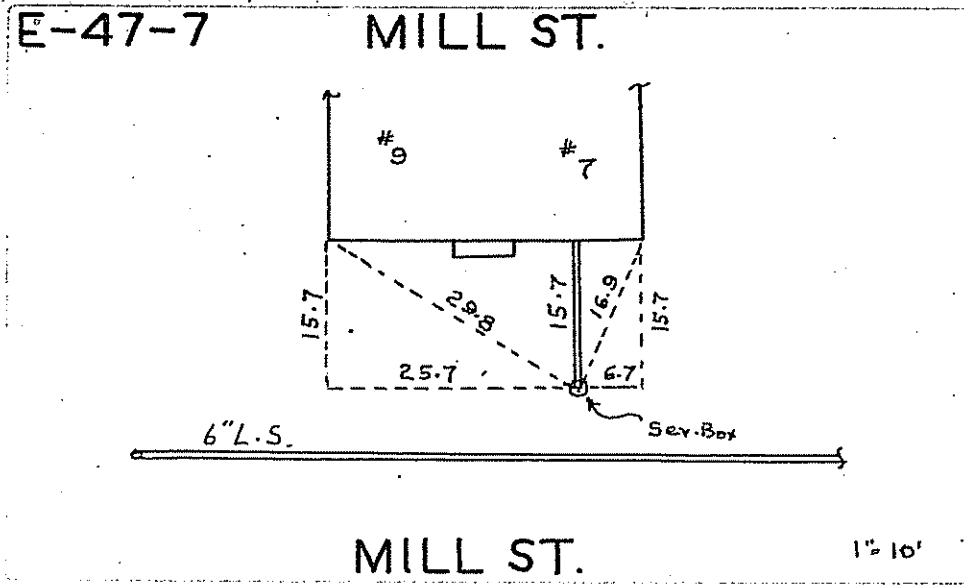

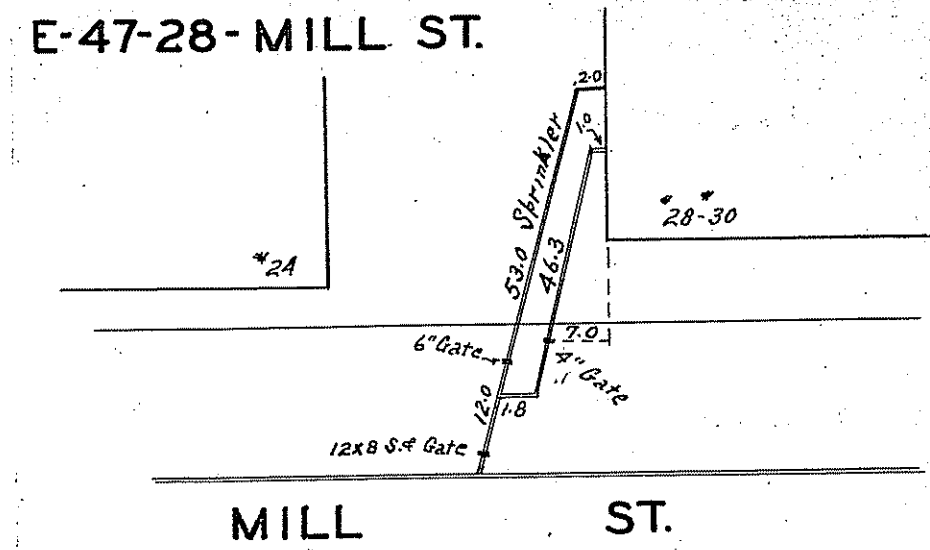
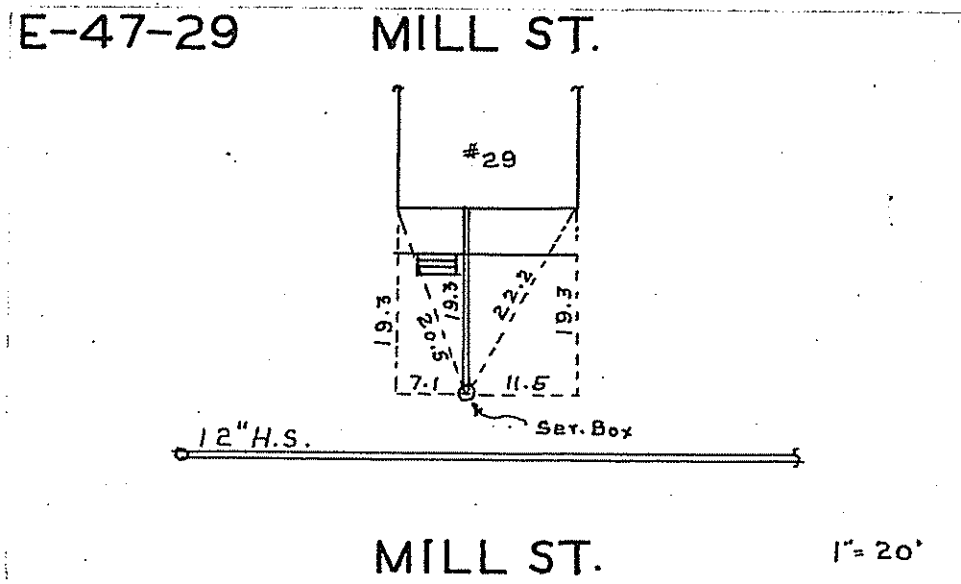
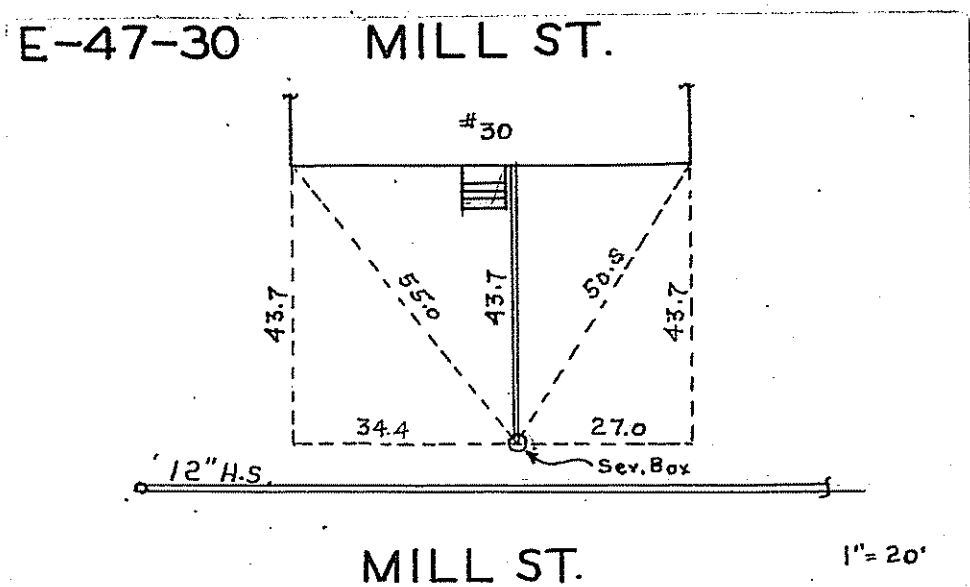
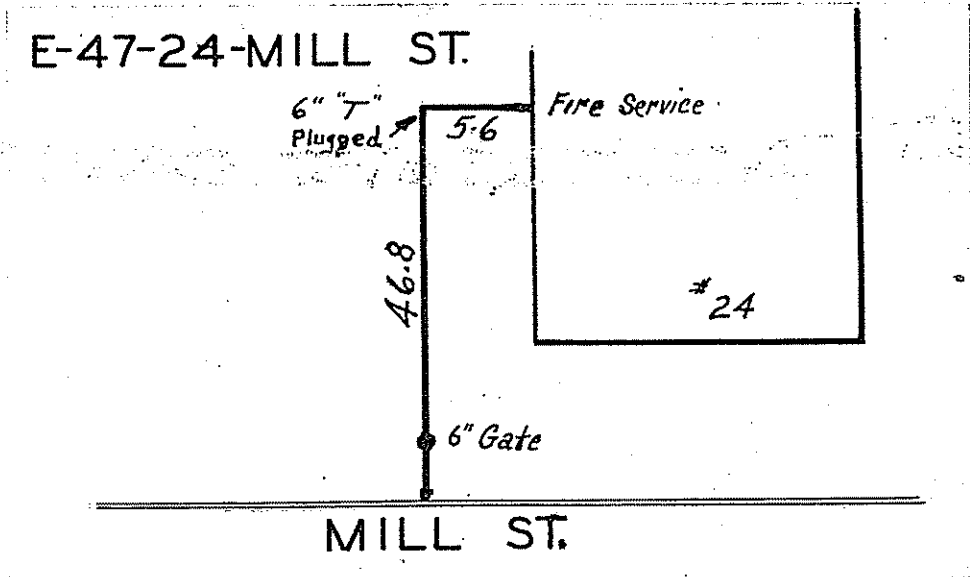
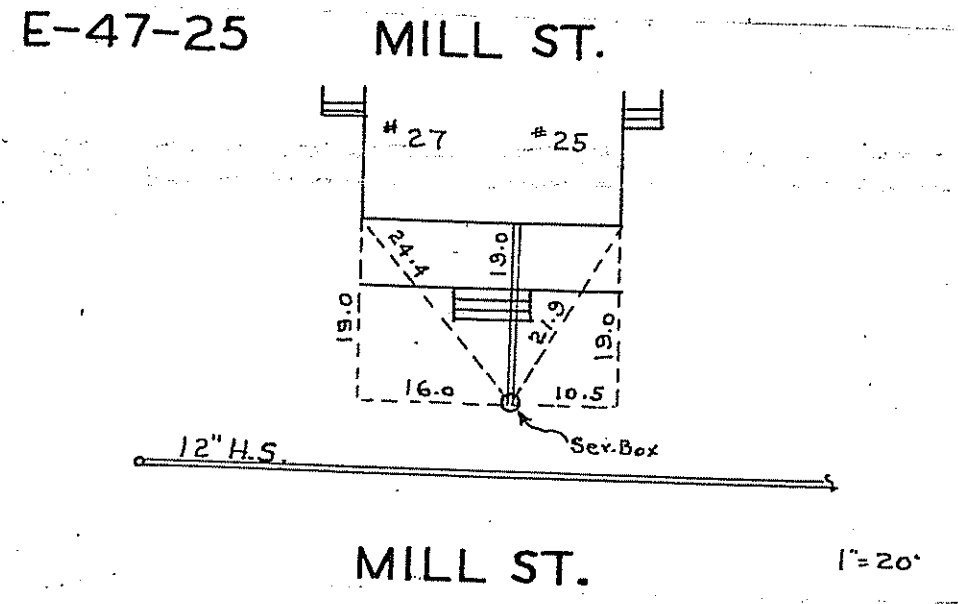
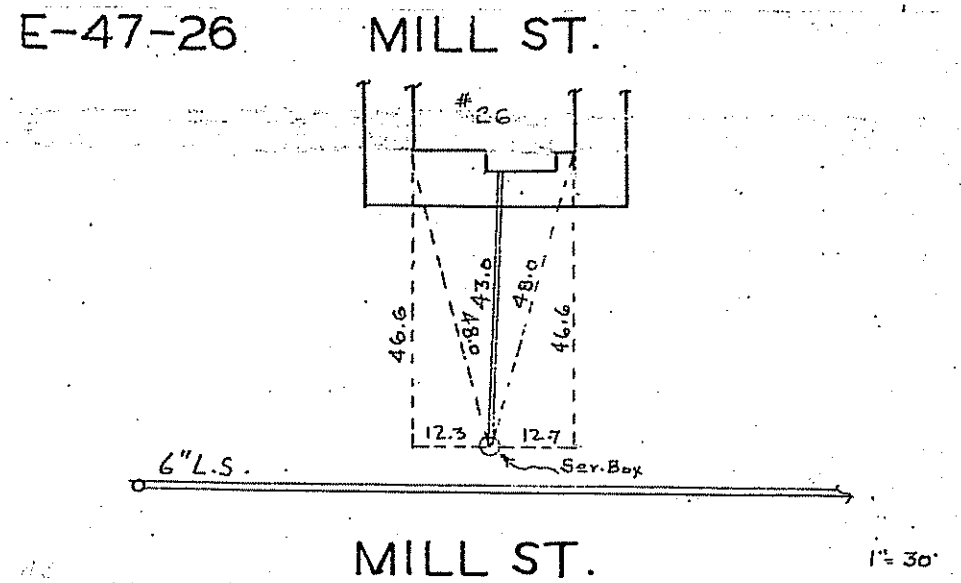
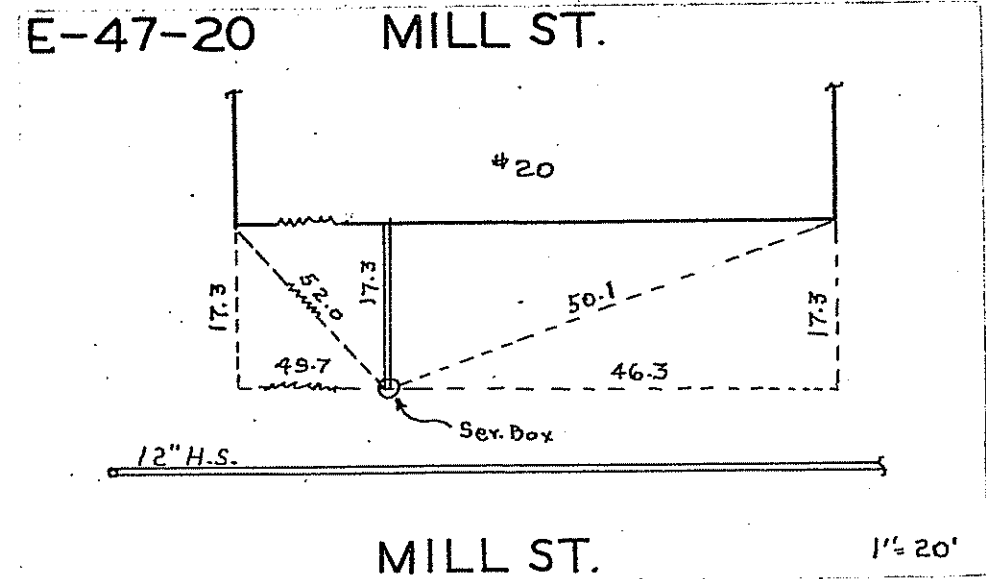
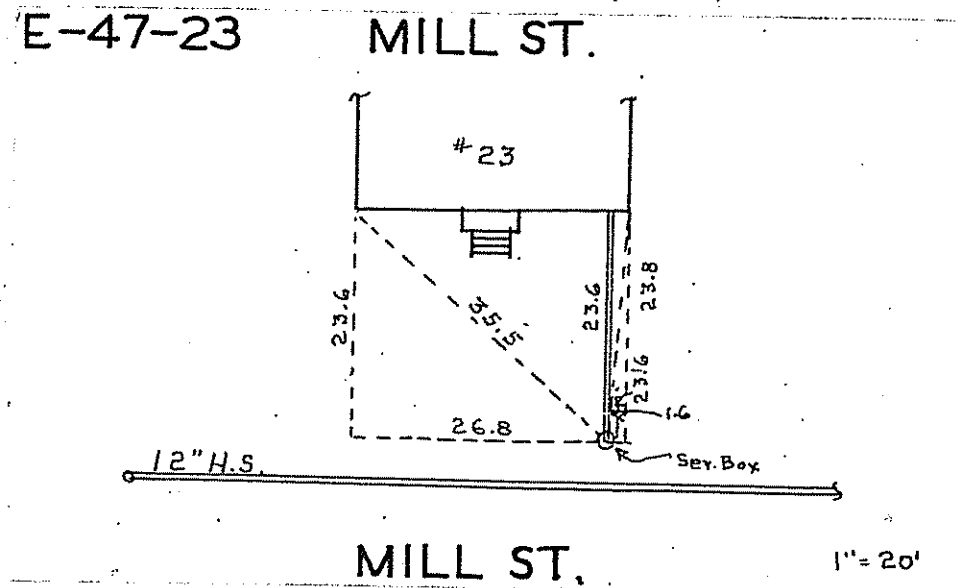
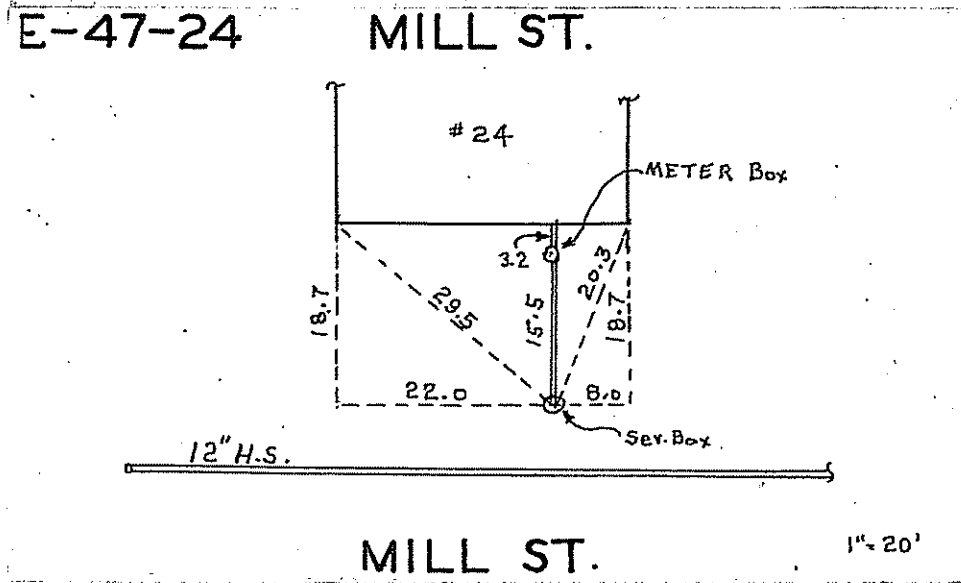

L.S.

401

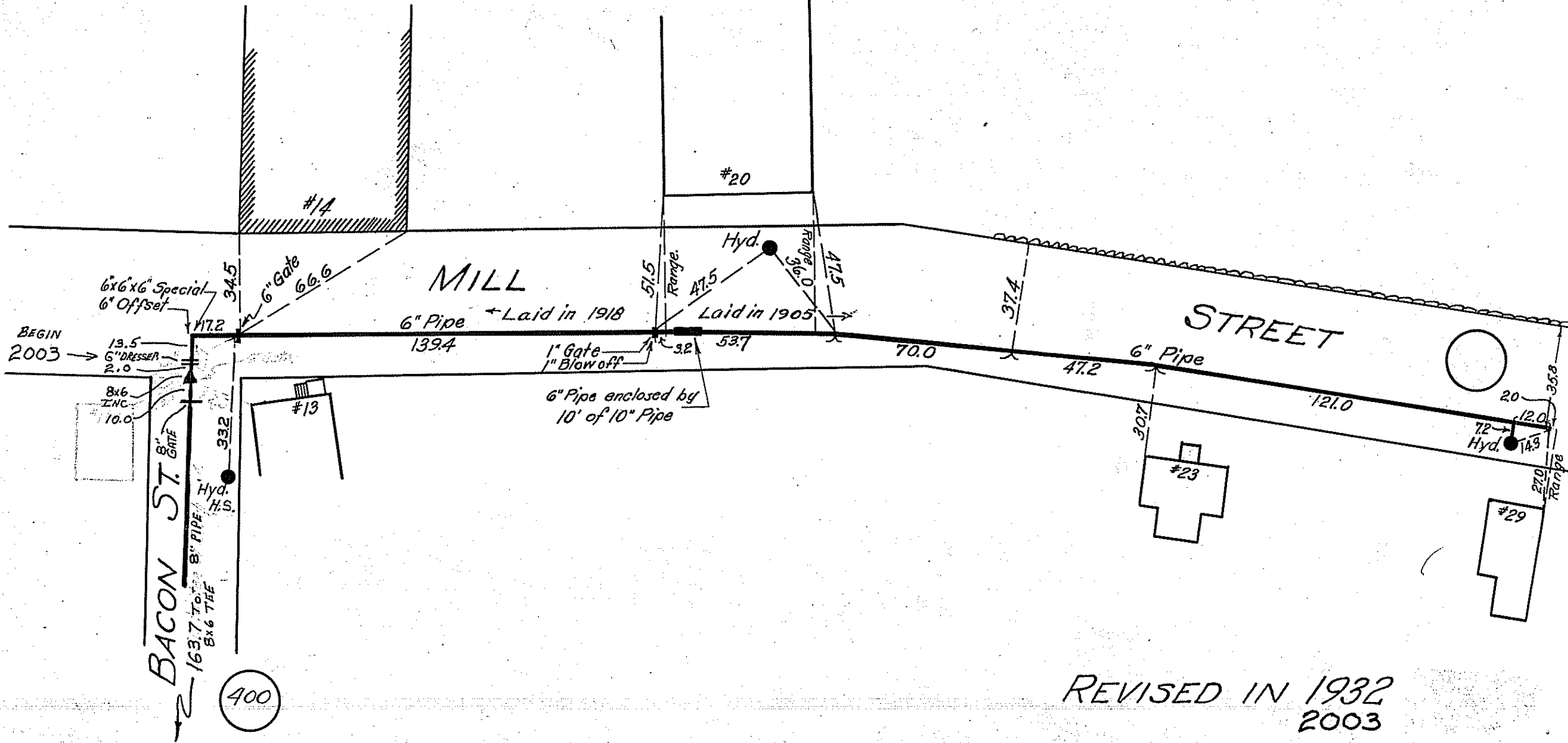

REVISED IN 1932
2003

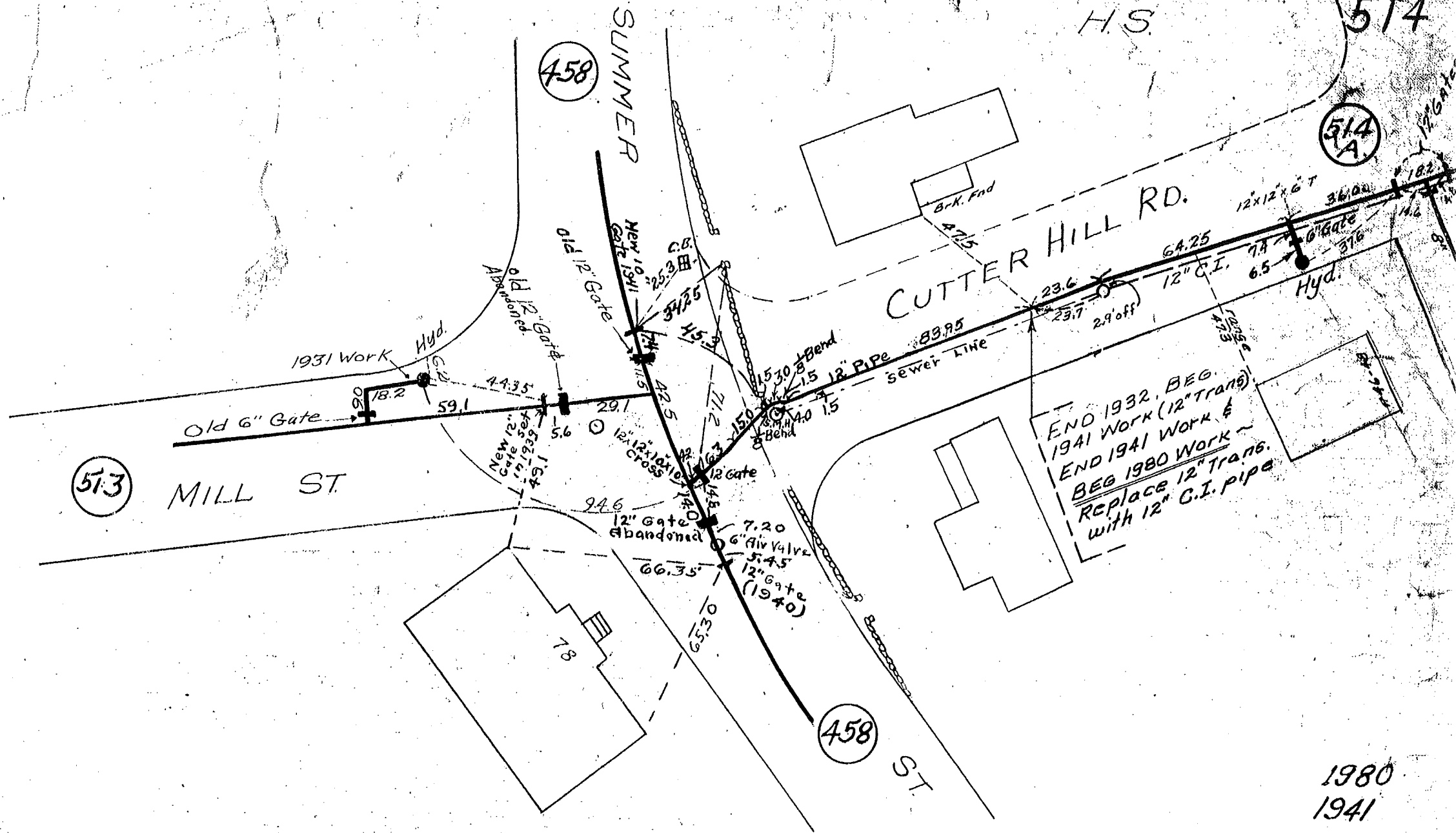

1980
 1941
 REVISED IN 1932

513

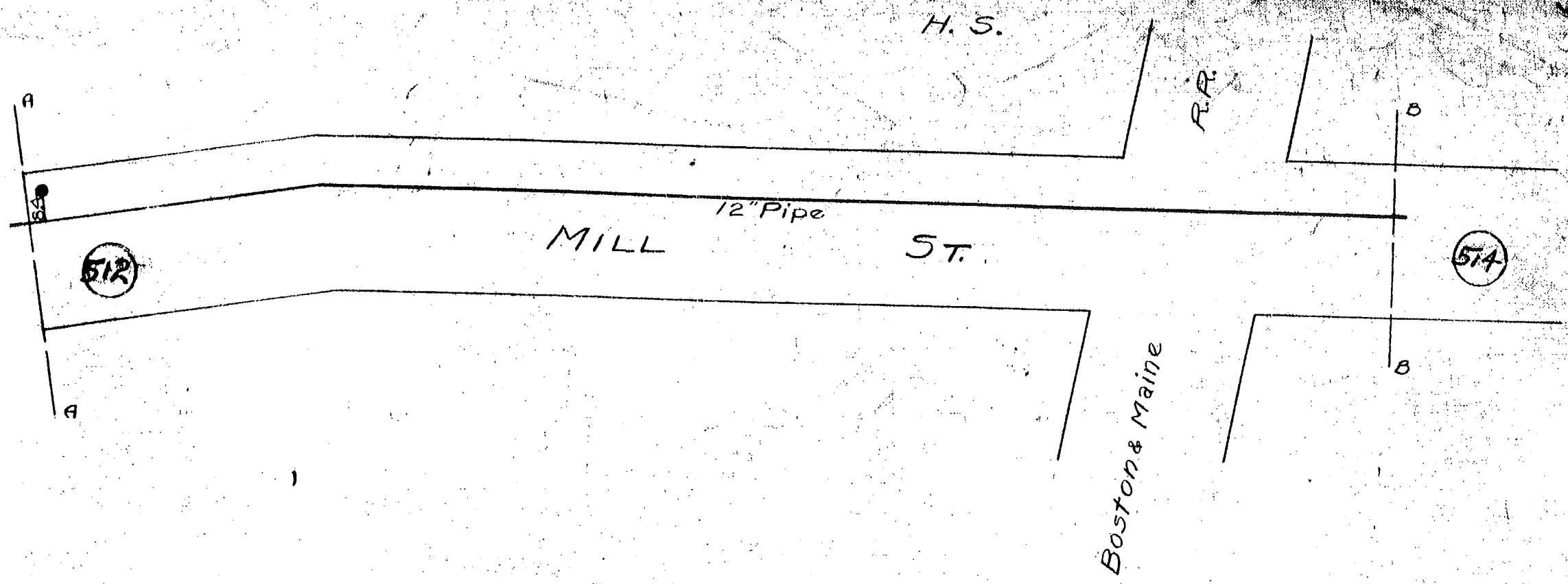

cc

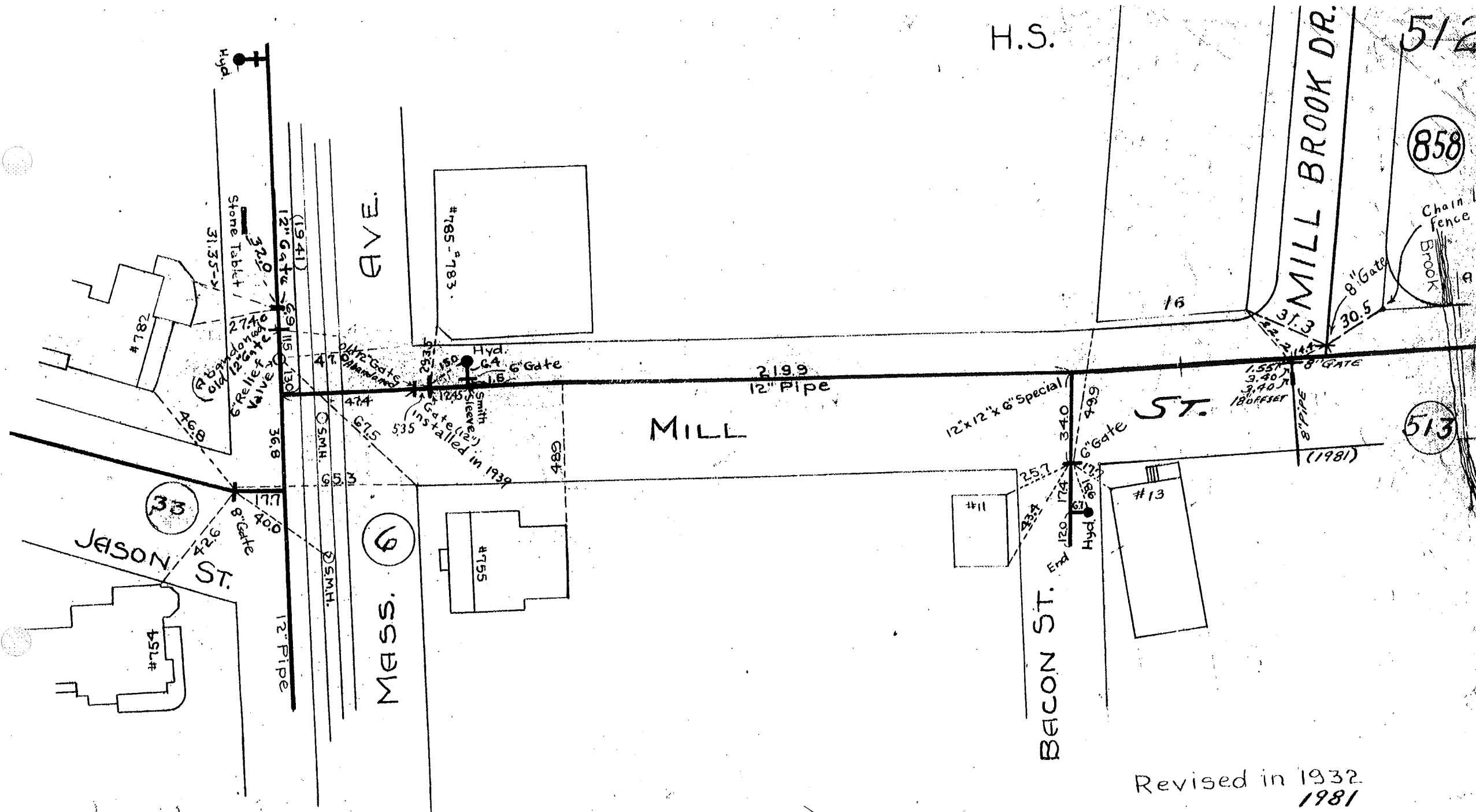

H.S.

5/2

858

Chain Link
fence Pos.
Brook

MILL BROOK DR.

5/3

MILL ST.

BEACON ST.

JASON ST.

AVE.

MILL

MASS. 6

Revised in 1932
1981

Hyd.

#785-783

#782

33

#754

4755

#11

#13

Stone Tablet /
31.35-21

(1941)
12" Gate

Relief Valve
12" Gate

Hyd. 6" Gate

2199
12" Pipe

12x12x6" Special

6" Gate

1.557
3.40
3.40
18' Buffer

8" Gate
30.5

36.8

OS.M.H.

OS.M.H.

424
615

535

489

120
174
123

Hyd. 6" Gate

(1981)

8" Gate

12" Pipe

29.5

150

12.45

Smith

Gate (2")

Installed in 1932

36.8

OS.M.H.

OS.M.H.

OS.M.H.

OS.M.H.

OS.M.H.

OS.M.H.

OS.M.H.

OS.M.H.

OS.M.H.

OS.M.H.

OS.M.H.

OS.M.H.

OS.M.H.

OS.M.H.

OS.M.H.

OS.M.H.

OS.M.H.

OS.M.H.

OS.M.H.

OS.M.H.

OS.M.H.

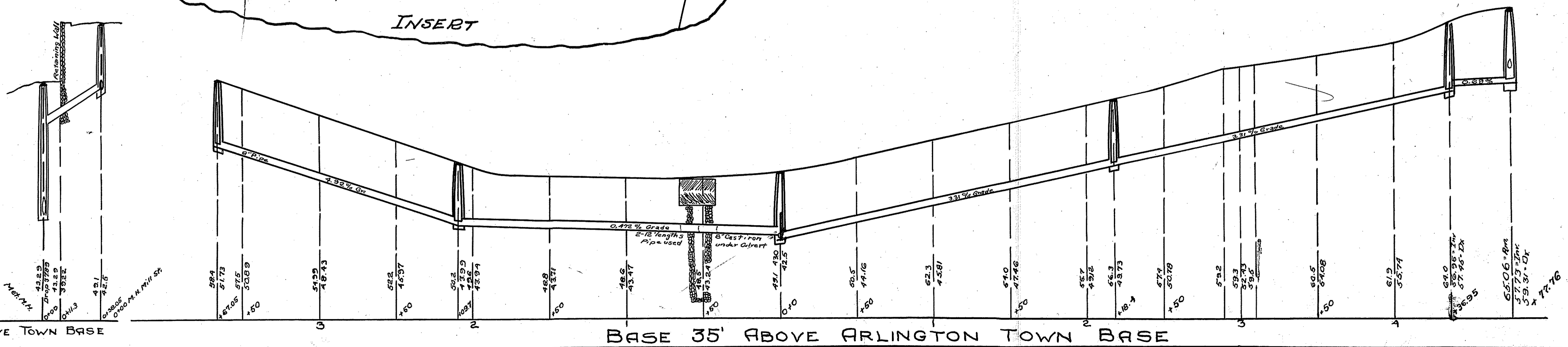
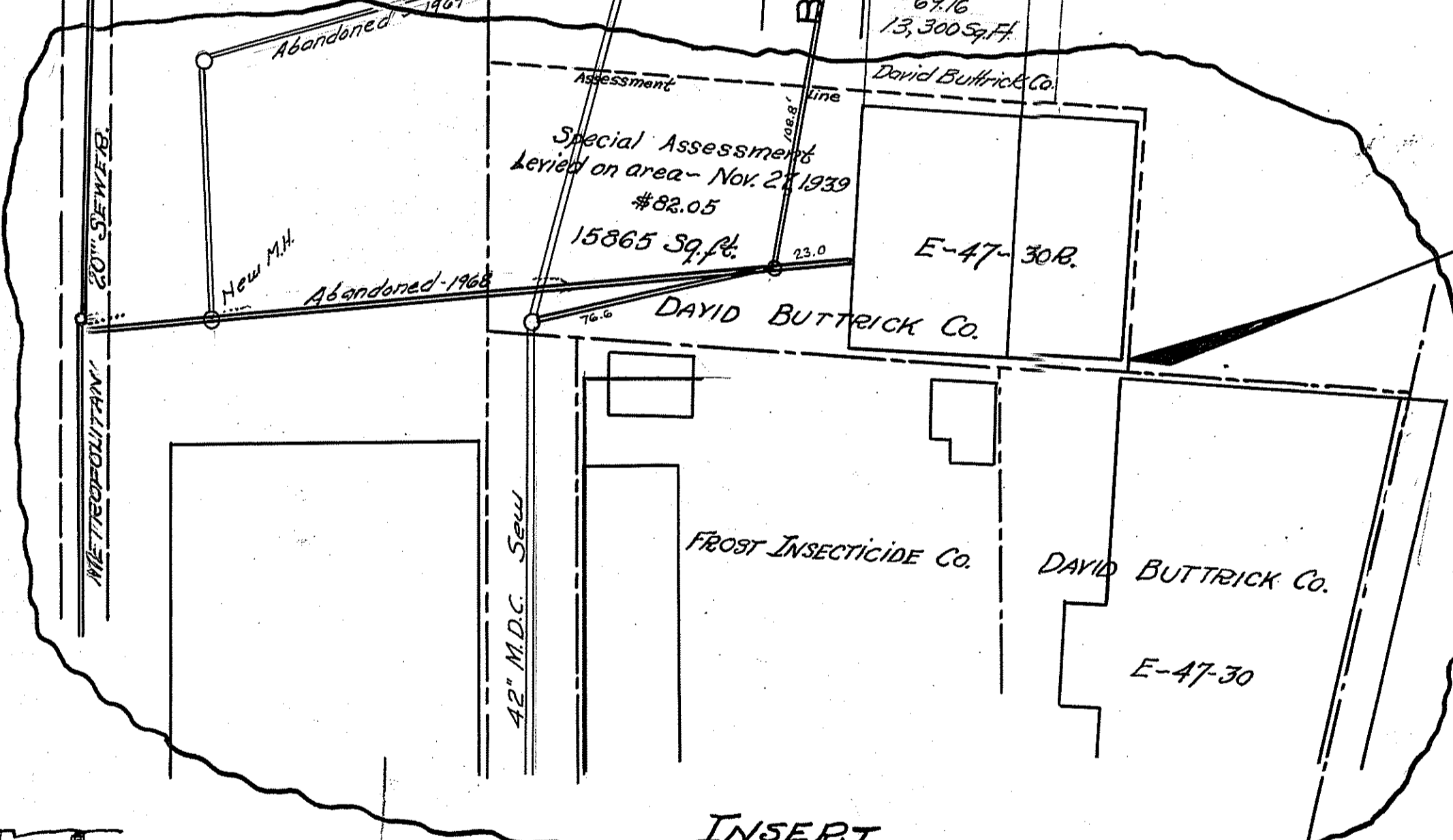
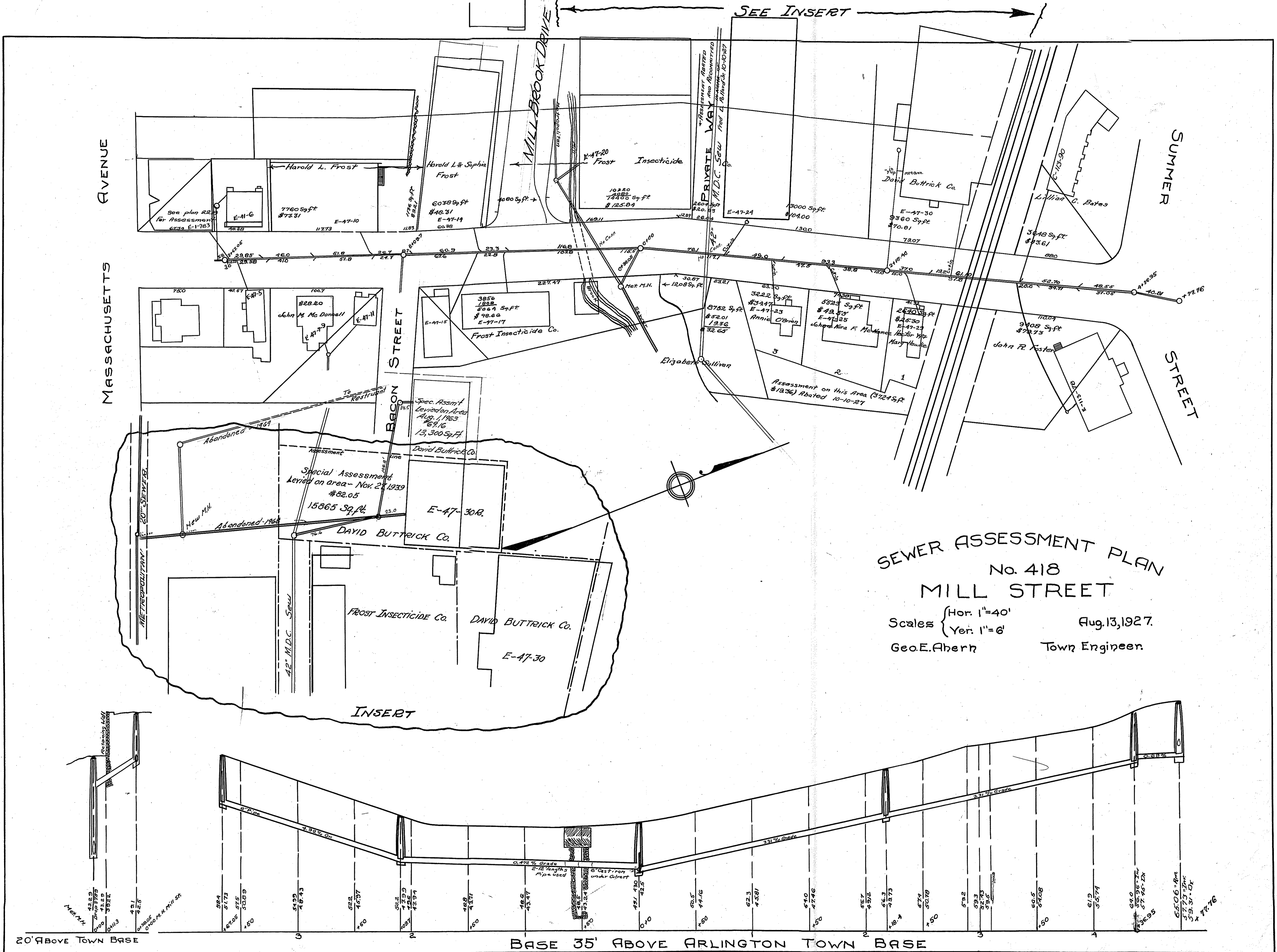

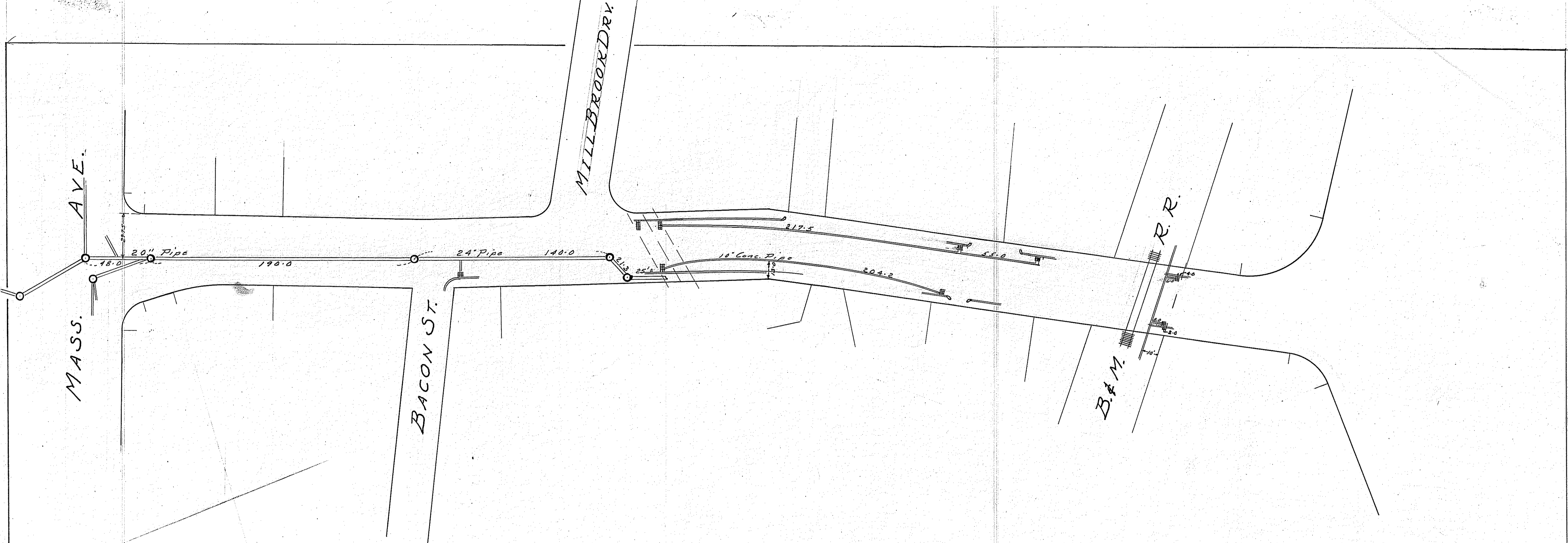

PLAN AND PROFILE
 OF
 STORM DRAIN
 IN
 MILL STREET
 ARLINGTON - MASS.

Hor. - 1" = 40'
 Scales - Ver. - 1" = 6' Jan. 1965

W. H. Roby - Town Eng'r.

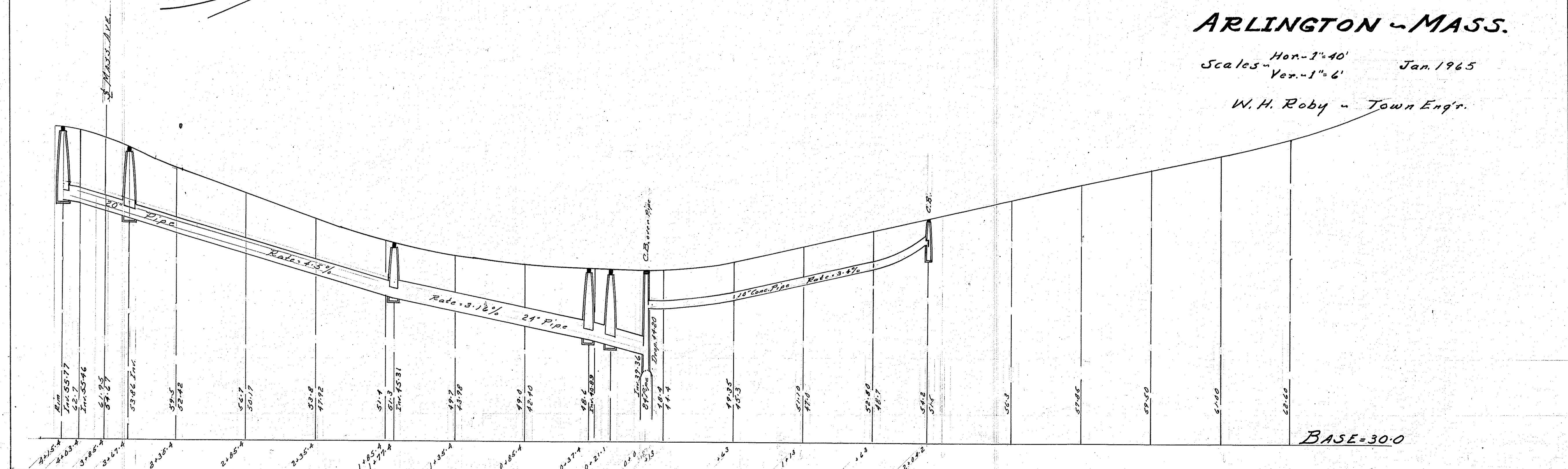

BASE = 30.0

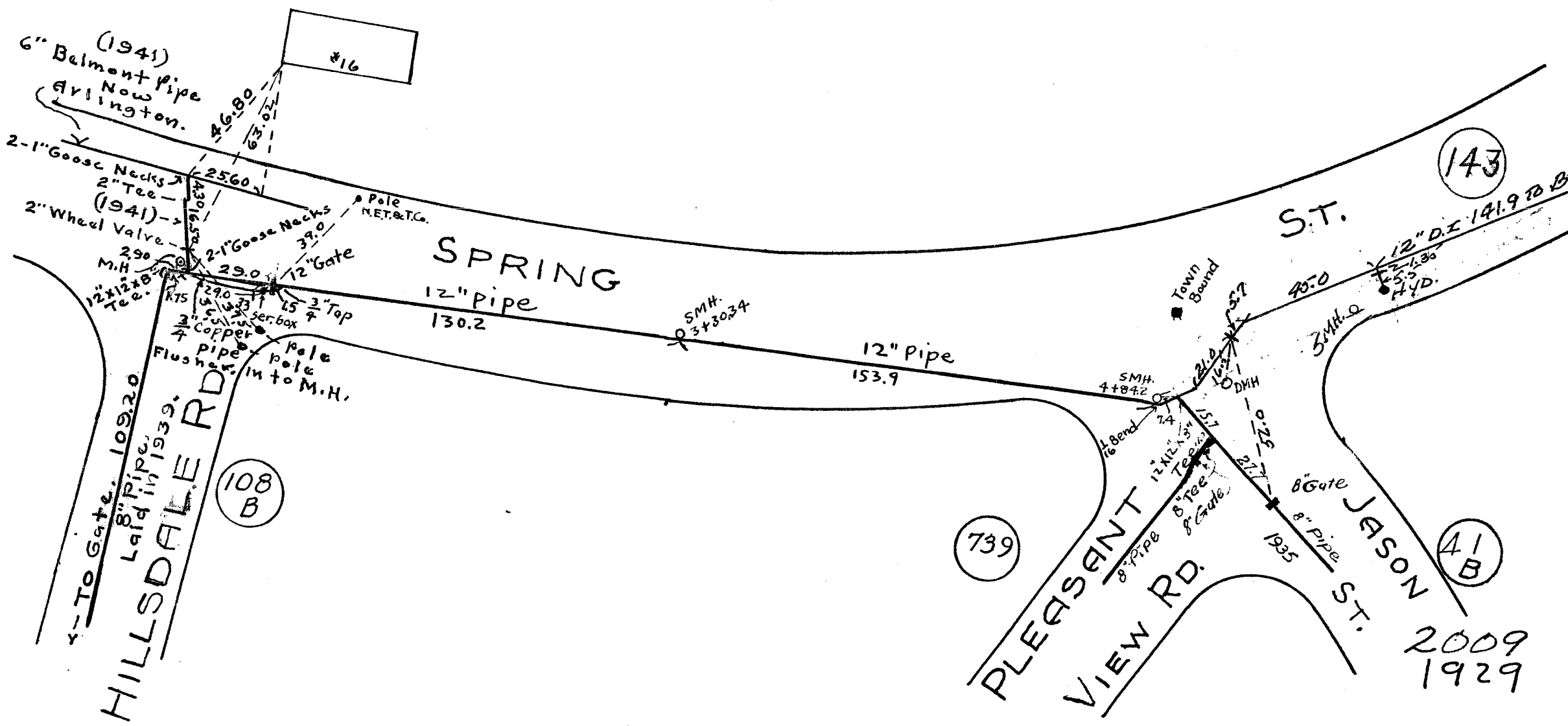

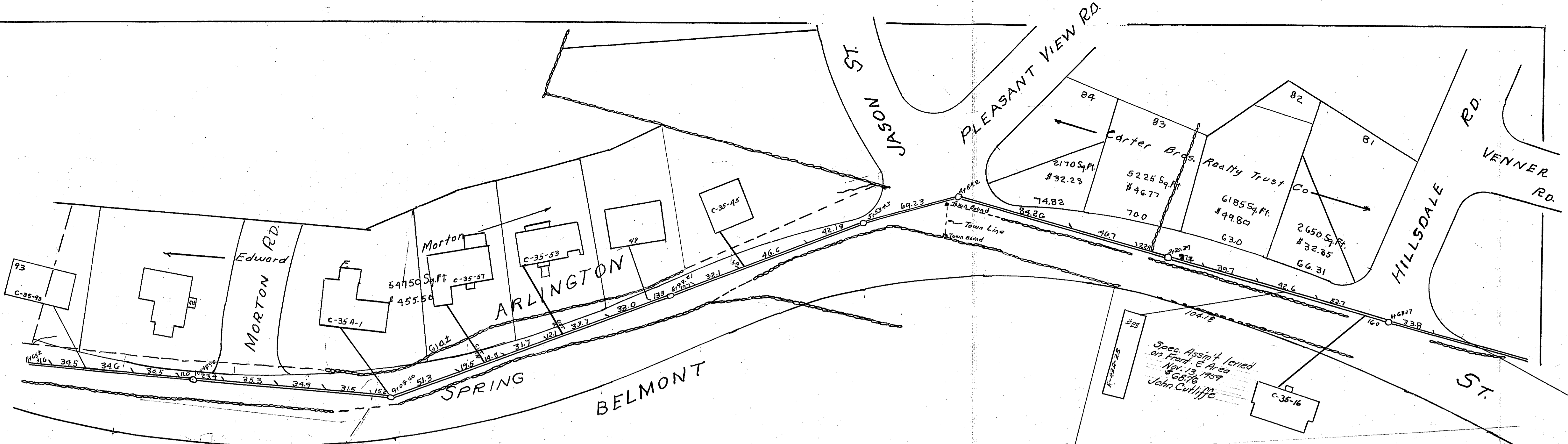

SEWER ASSESSMENT PLAN
 No. 495
SPRING STREET
 Scales Hor. 1" = 40'
 Ver. 1" = 6'
 Dec. 6, 1929.
 J.M. Keane
 Town Engineer

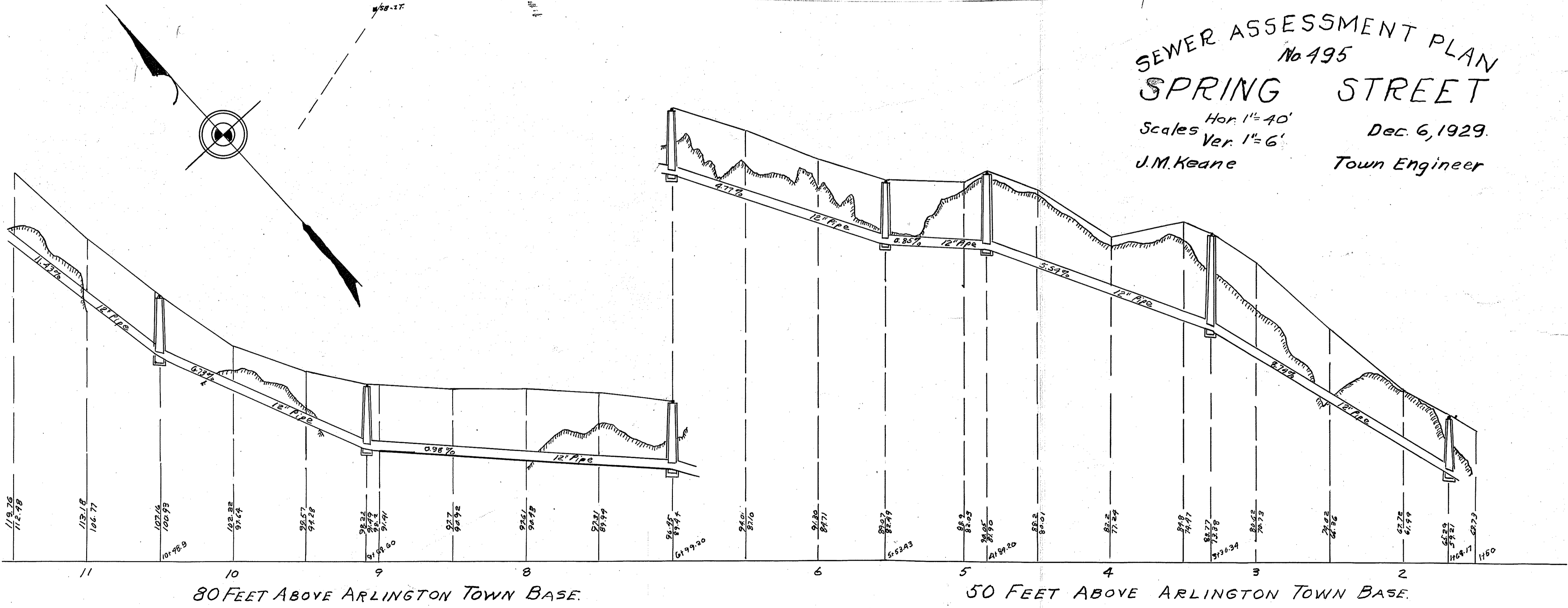

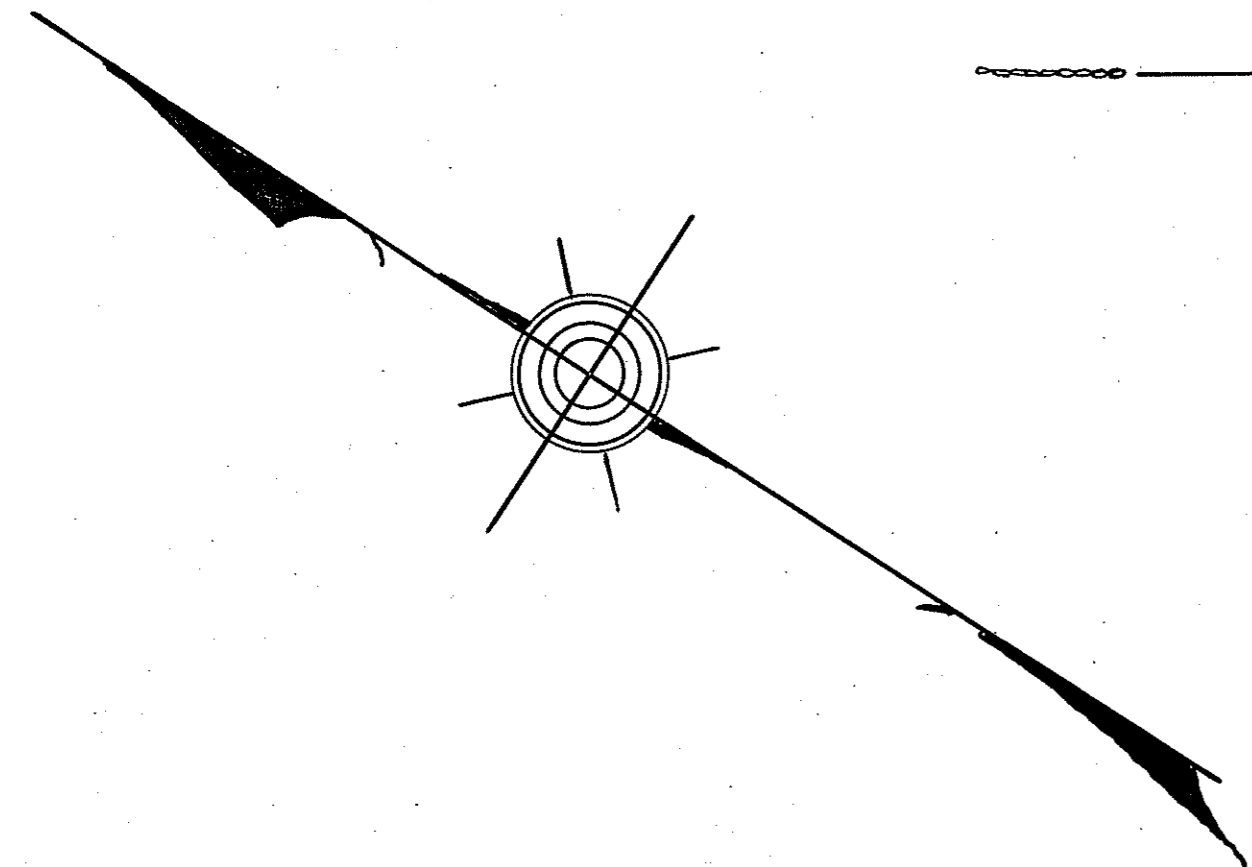
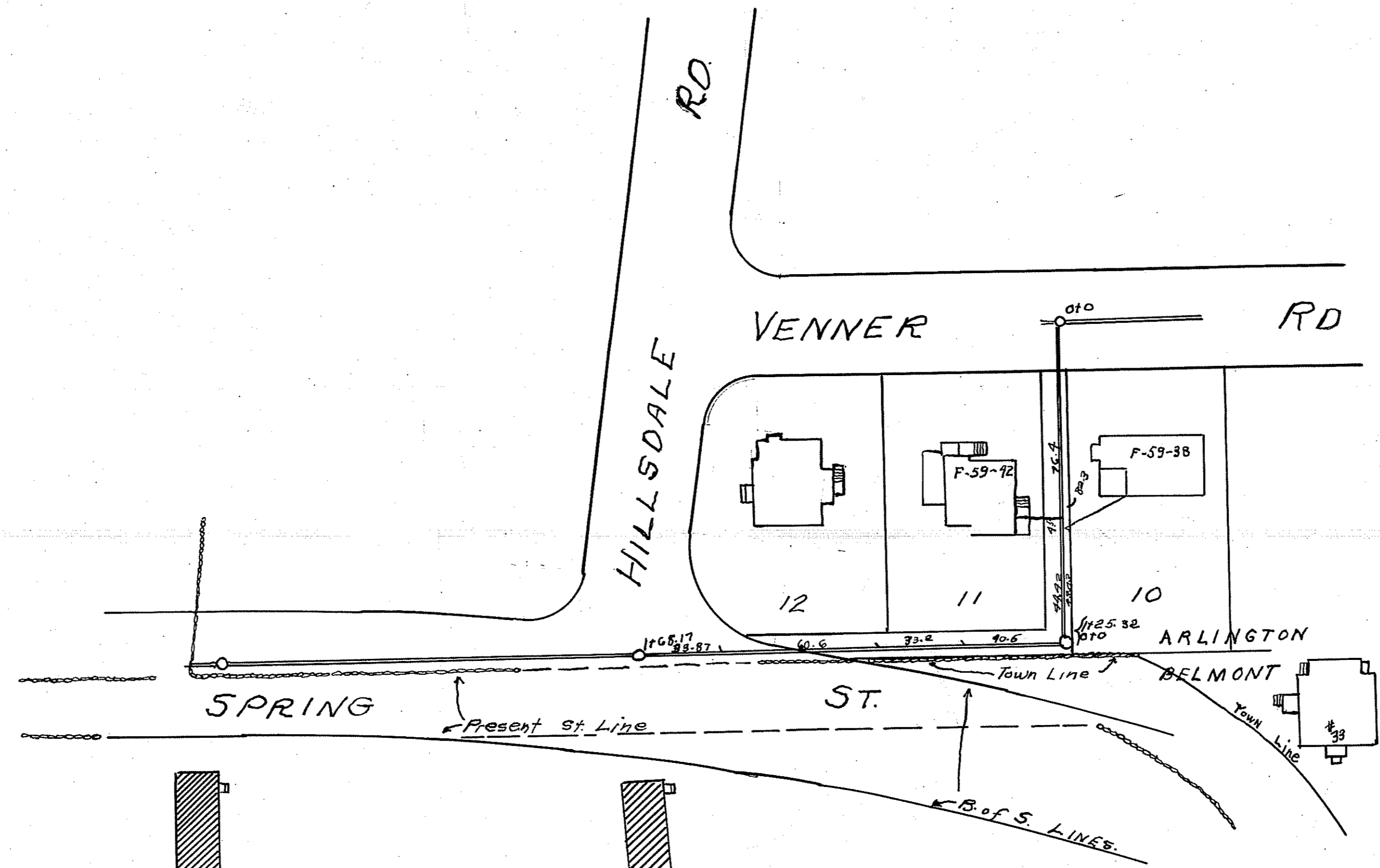

SEWER ASSESSMENT PLAN
 No. 494
 PRIVATE LANDS
 Scales Hor. 1"=40'
 Ver. 1"=6' Dec. 2, 1929
 J. M. Keane Town Engineer
 NOTE Assessments to be levied when
 houses are built.

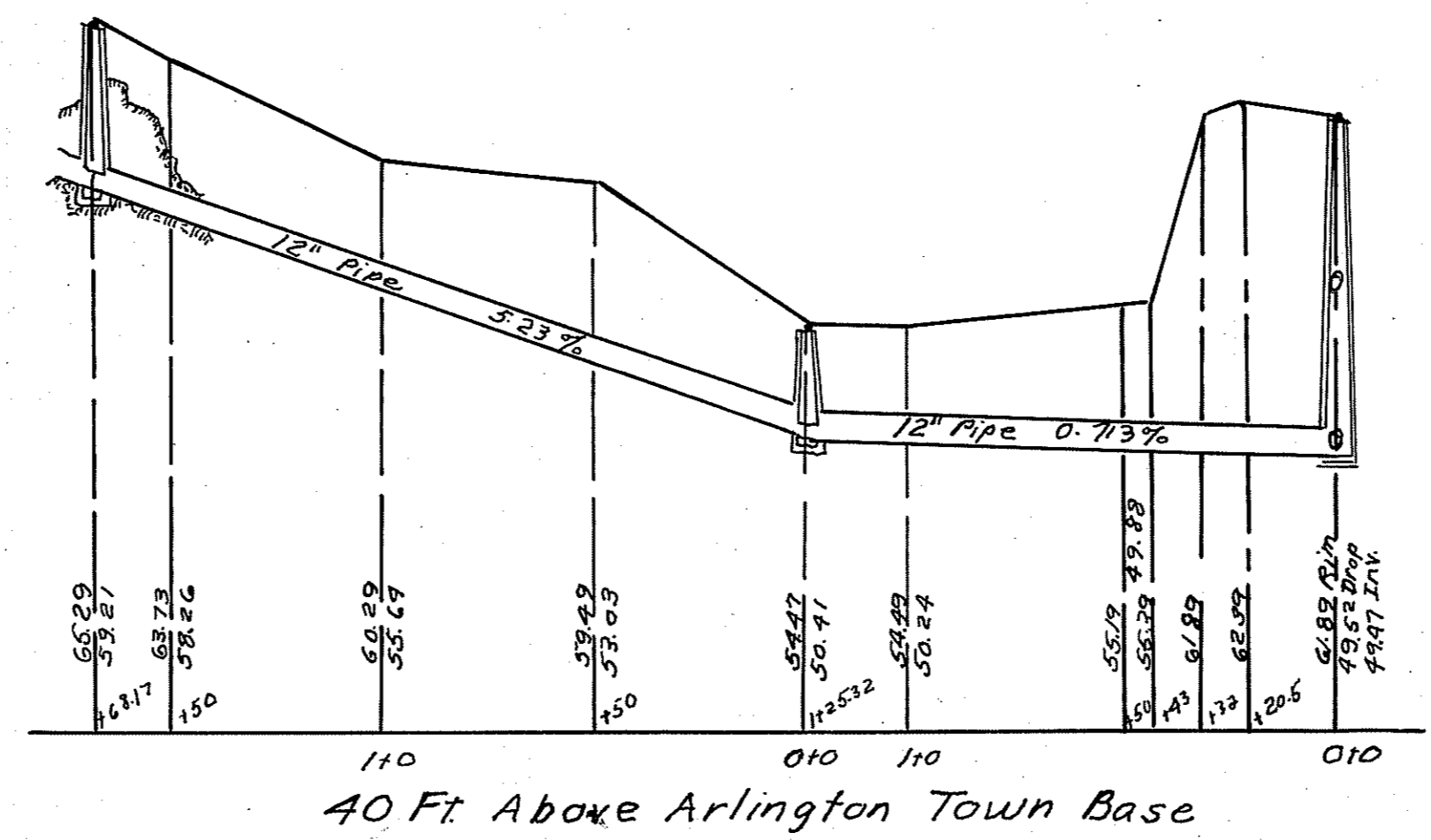

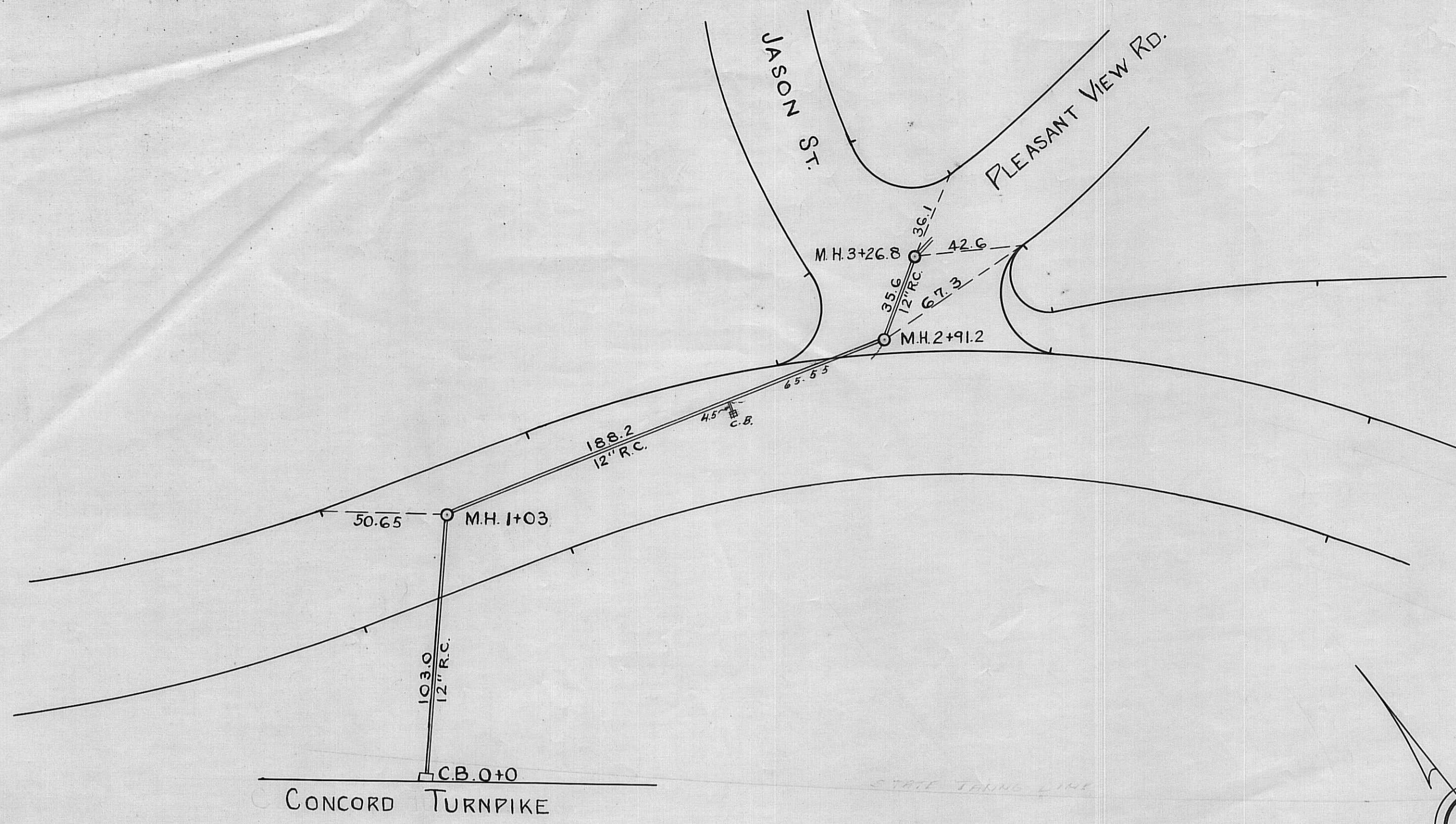

PLAN & PROFILE OF
 STORM DRAIN
 IN
 SPRING STREET & PRIVATE LANDS
 ARLINGTON, MASS
 SCALES: HOR. 1"=40', VERT. 1"=6'
 OCT, 1954
 JAMES M. KEANE TOWN ENGINEER

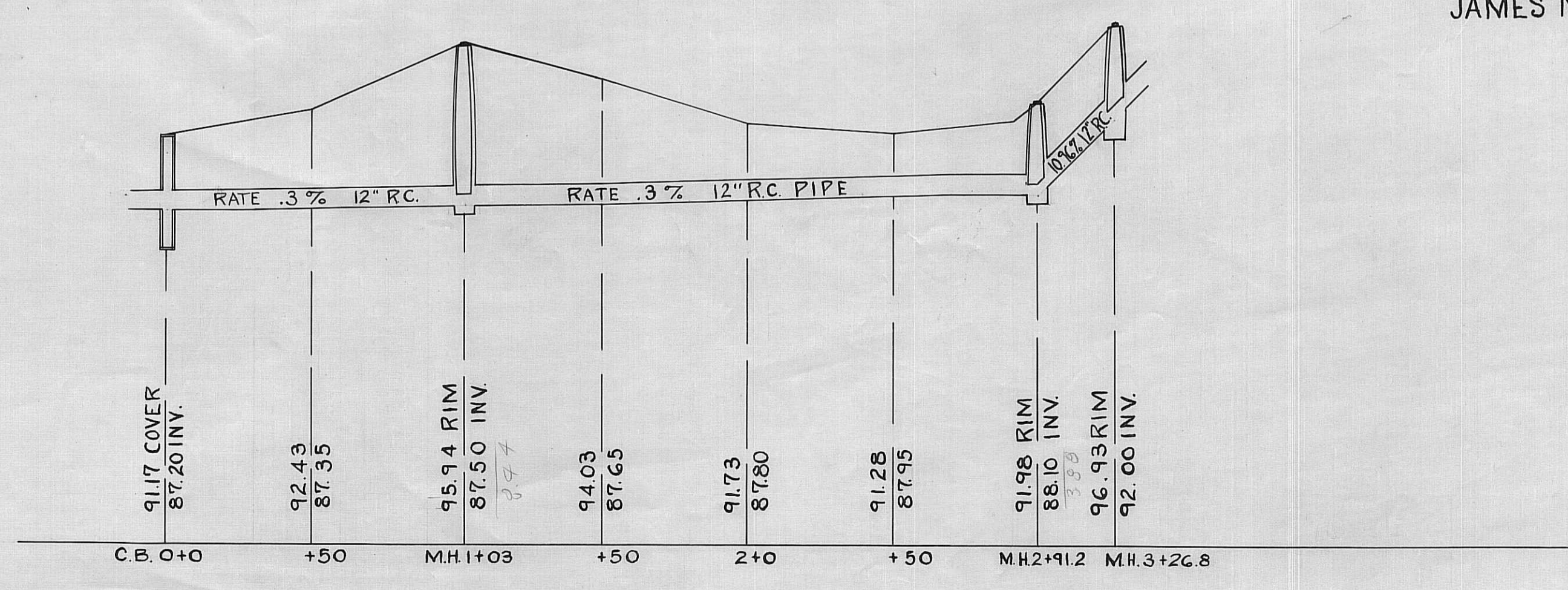

BASE IS 70 FT. ABOVE ARLINGTON TOWN BASE

00-19

BURCH ST.

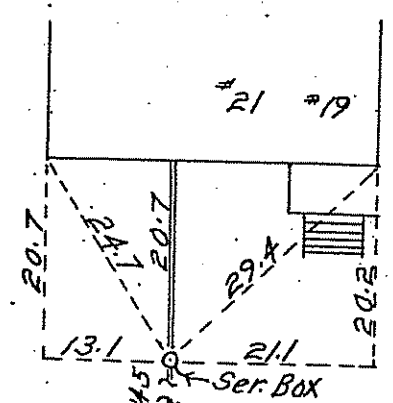

6" L.S.

F-68-31

BURCH ST.
BURCH ST.

1"=20'

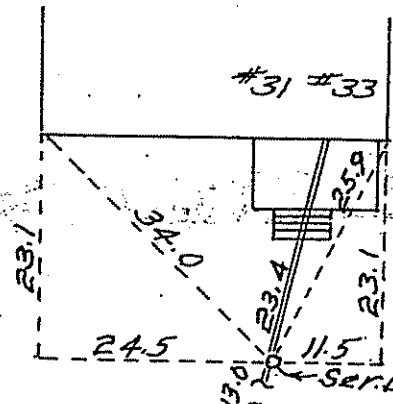

6" L.S.

BURCH ST.

1"=20'

F-68-47

BURCH ST.

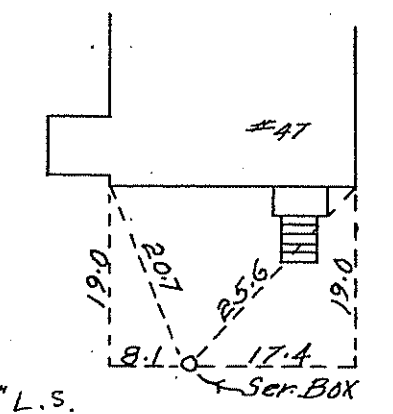

8" L.S.

BURCH ST.

1"=20'

7.5

08-15

BURCH ST.

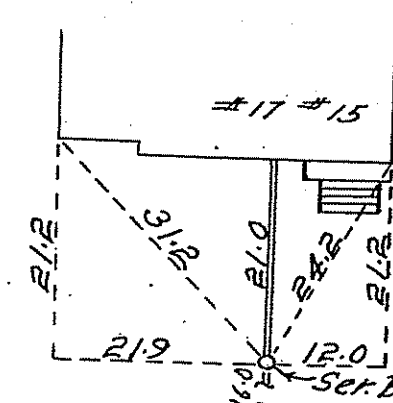

6" L.S.

F-68-27

BURCH ST.
BURCH ST.

1"=20'

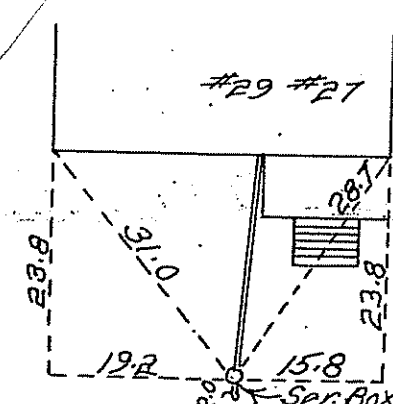

6" L.S.

BURCH ST.

1"=20'

F-68-43

BURCH ST.

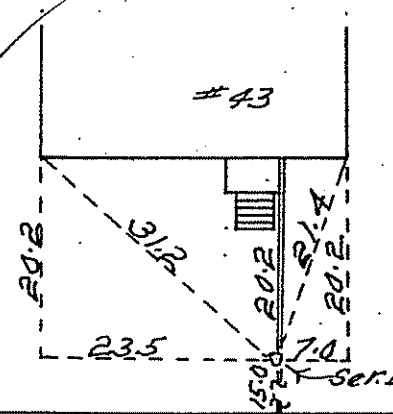

6" L.S.

BURCH ST.

1"=20'

08-11

BURCH ST.

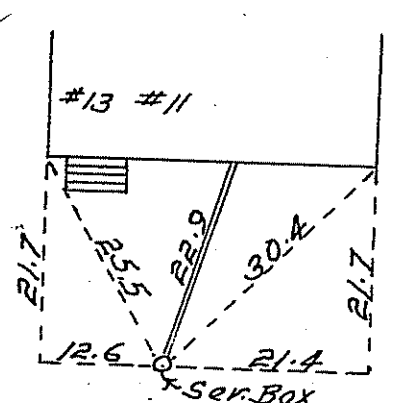

6" L.S.

F-68-23

BURCH ST.
BURCH ST.

1"=20'

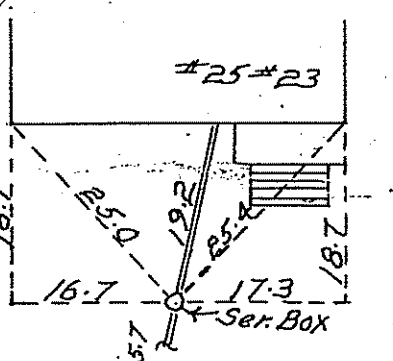

6" L.S.

WHITE ST.

BURCH ST.

1"=20'

F-68-35

BURCH ST.

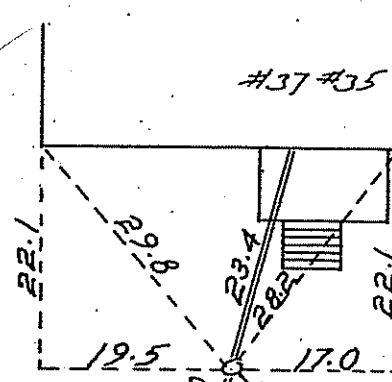

6" L.S.

BURCH ST.

1"=20'

MARY ST.

L.S.

120

121

127

85

112

126

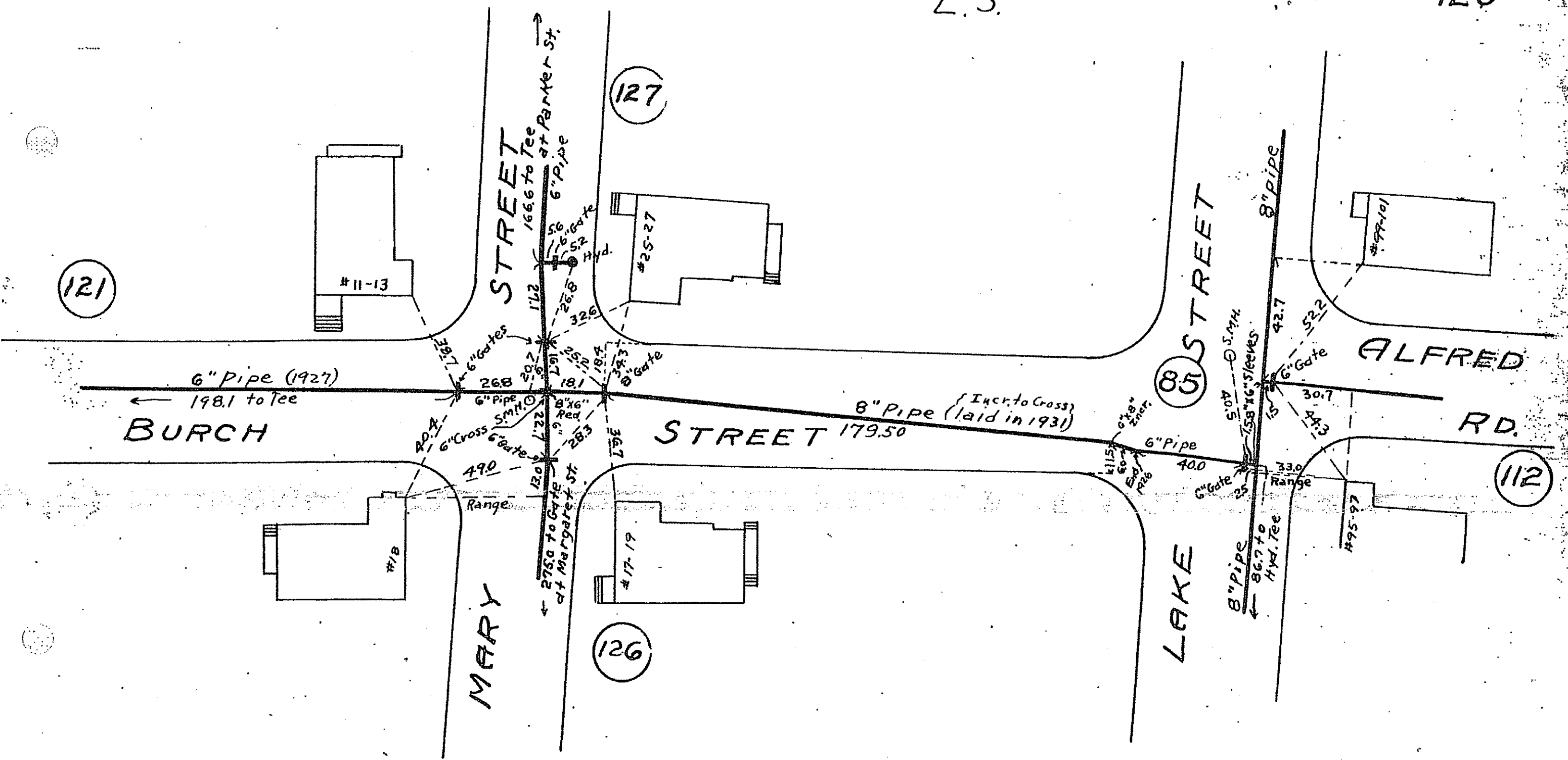

REVISED 1932

L.S.

121

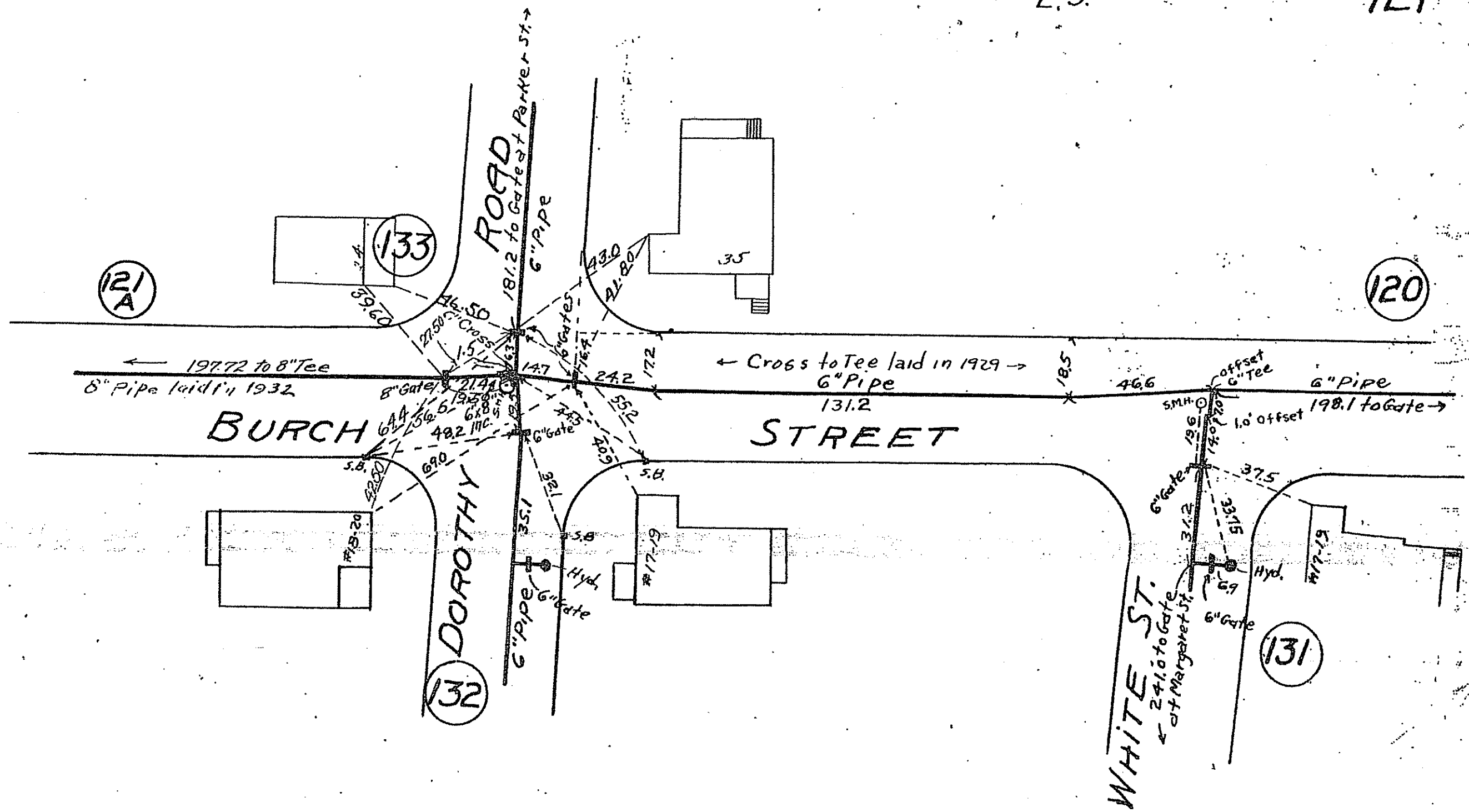

← 197.72 to 8" Tee
8" Pipe laid in 1932

← Cross to Tee laid in 1929 →
6" Pipe

BURCH STREET

DOROTHY

WHITE ST.

REVISED 1932

LS

121A

ROAD

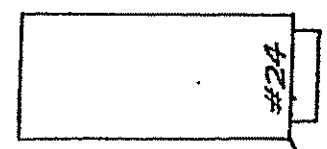

30.00

8" Gate

192.72

8" Pipe

BURCH STREET

22.50

(121)

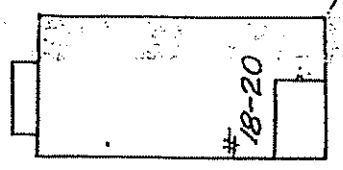

DOROTHY

1951
1932

OSBORNE ROAD

(134)

+273.3 to Gate at Margaret St

41.33

6" Gate

46.80

SM.H. 14.5

8" Tee

15.5

6"x8" increaser
8" offset Down

1951 Work

199.1' 8" Transit Pipe

S.M.H.

EDITH ST.

(135)

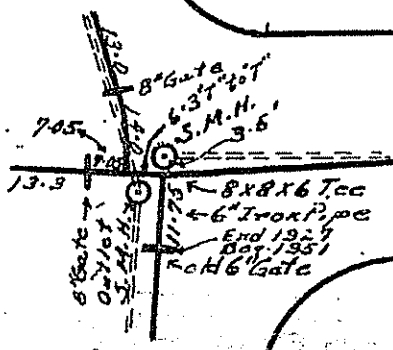
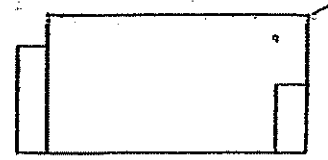

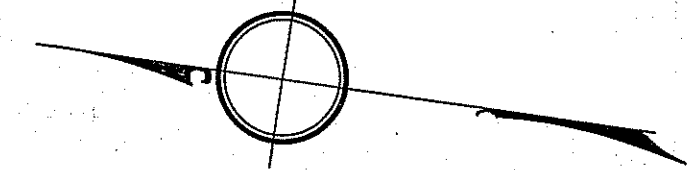
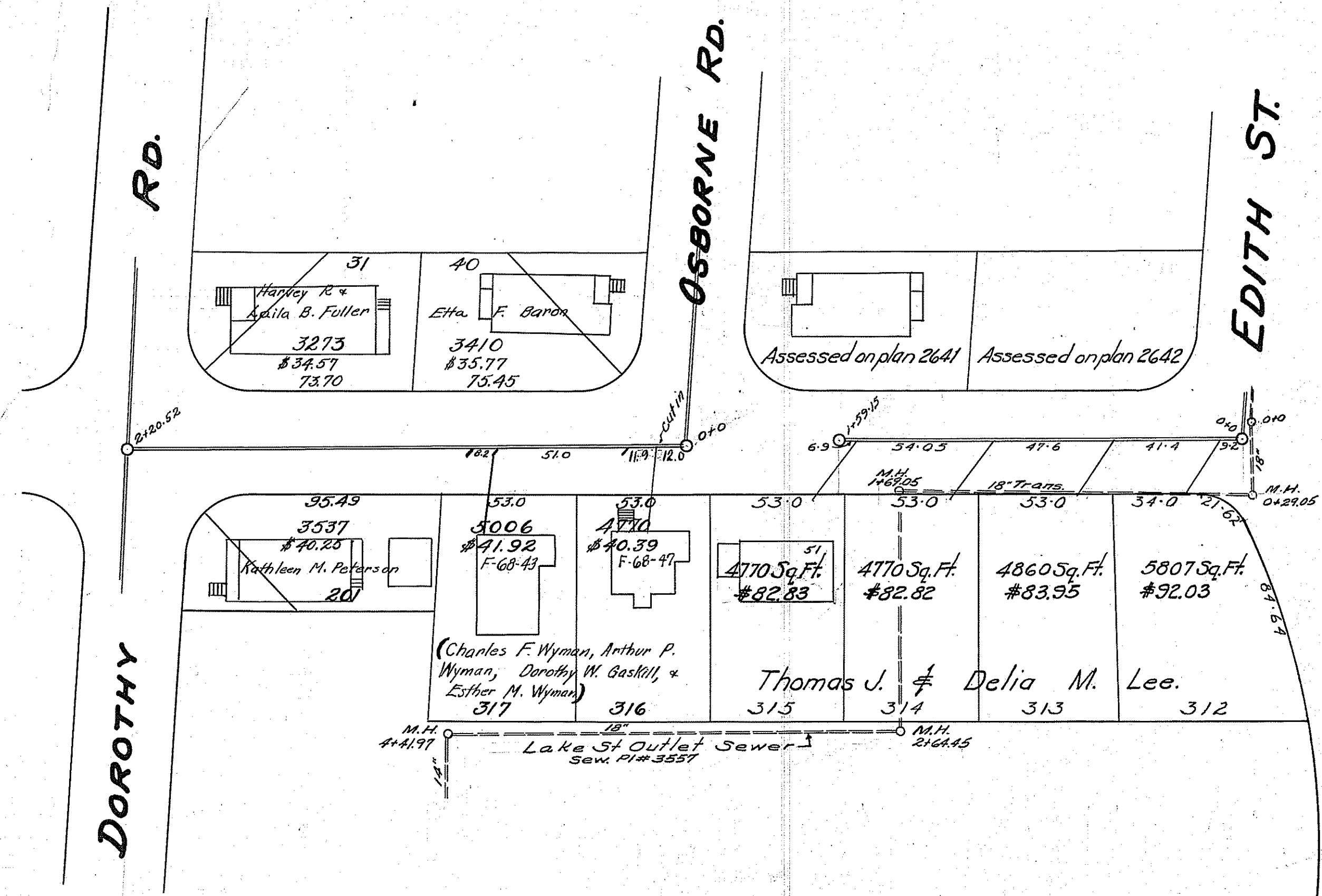

SEWER ASSESSMENT PLAN
No. 583
BURCH STREET

Scales: Hor. 1" = 40'
 Ver. 1" = 6'
 Date: June 27, 1932
 James M. Keane, Town Engineer.
 Note: From sta. 0+0 at Edith St. to sta. 1+59.15 installed in 1951. Assim'ts. levied May 1952.

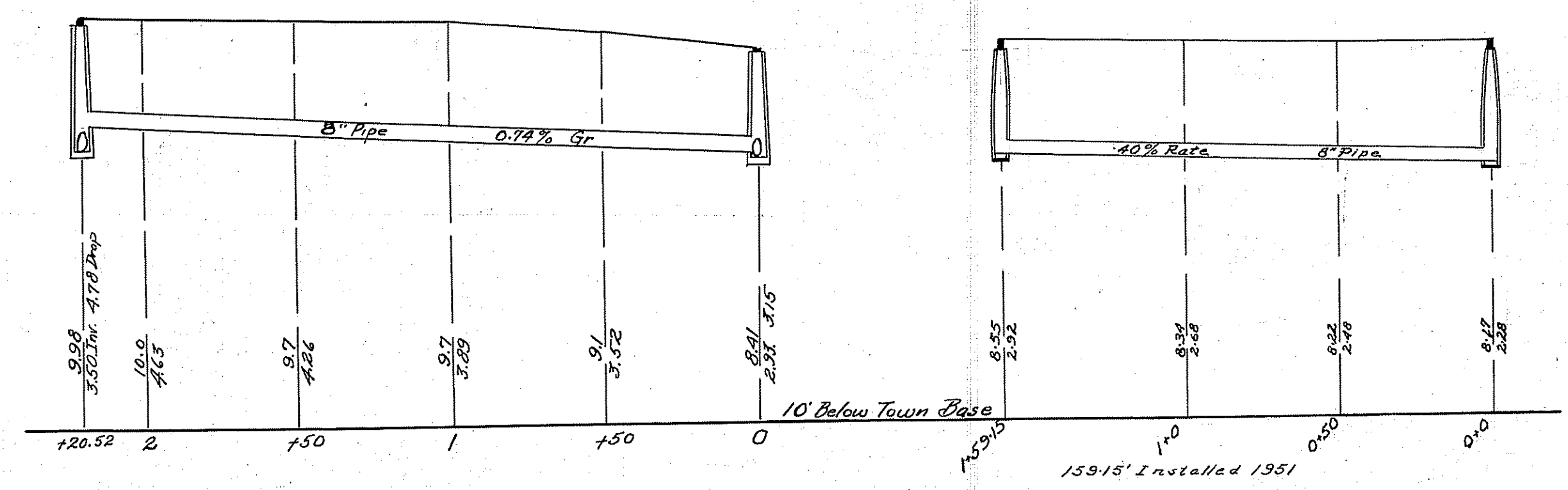

143
 7-00
 6960
 14160

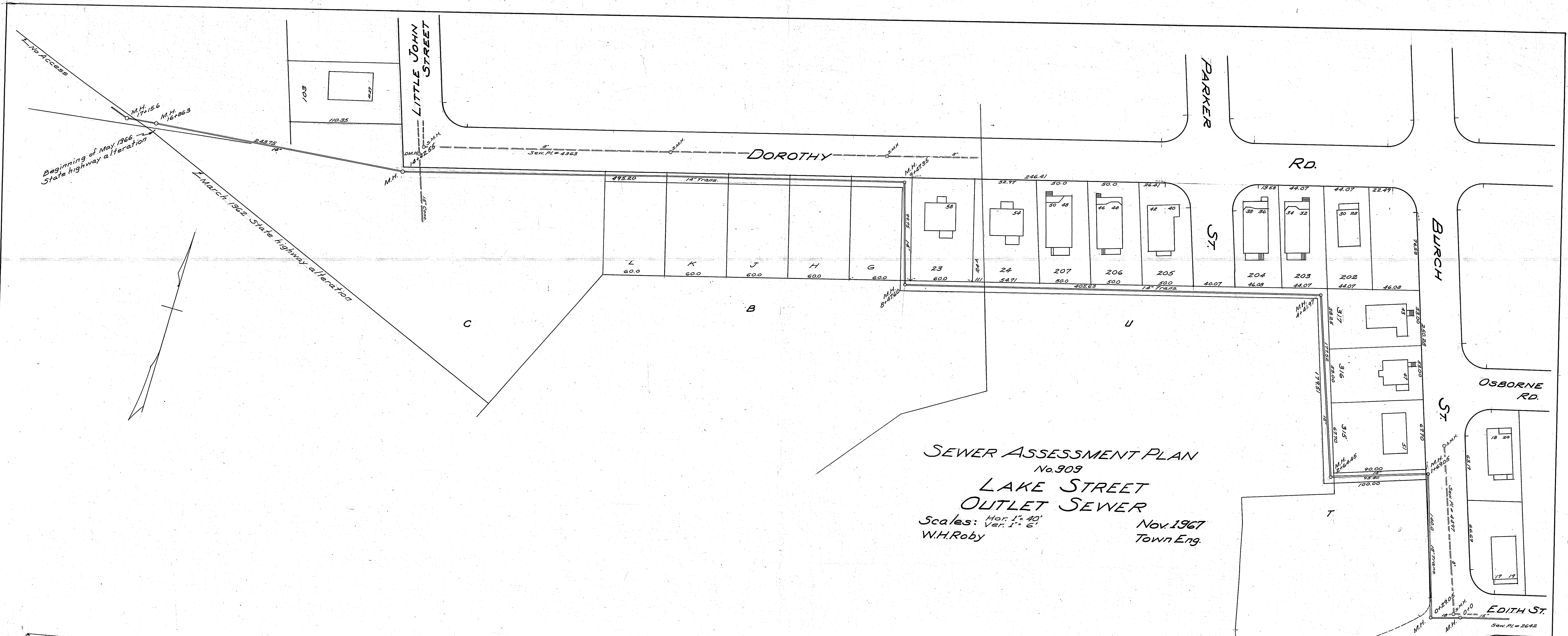

SEWER ASSESSMENT PLAN No. 909 LAKE STREET OUTLET SEWER

Scales: Hor. 1" = 40'
Ver. 1" = 6'

Nov. 1967
Town Eng.
W.H. Roby

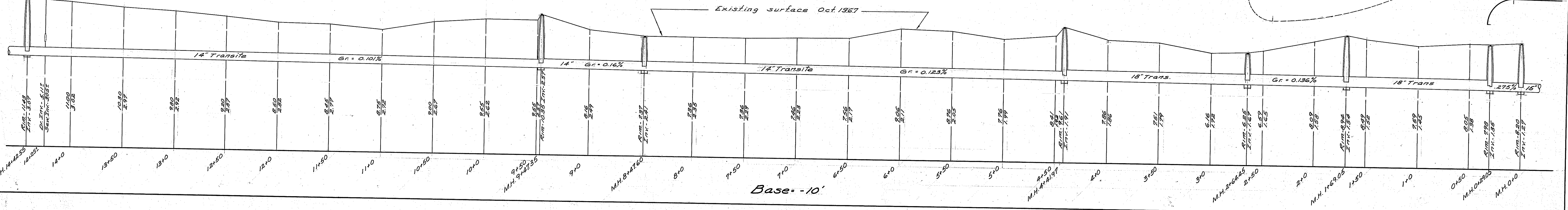

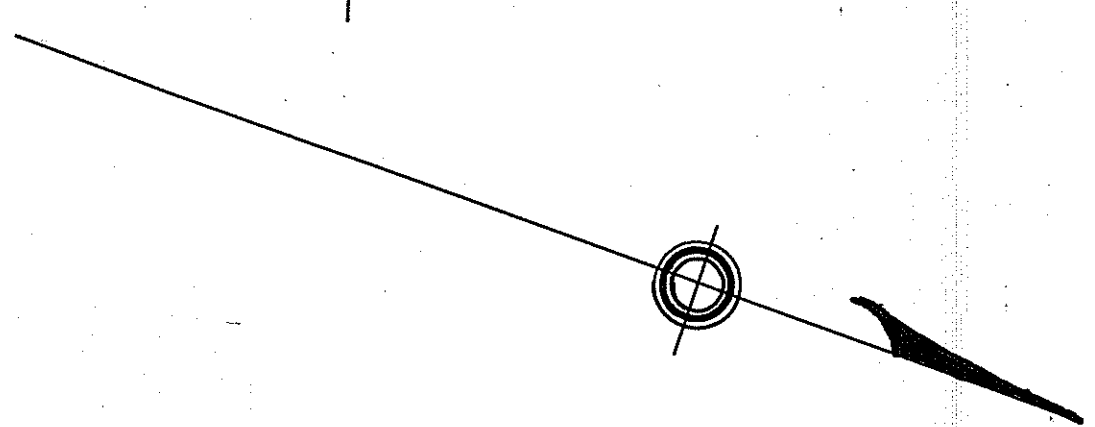
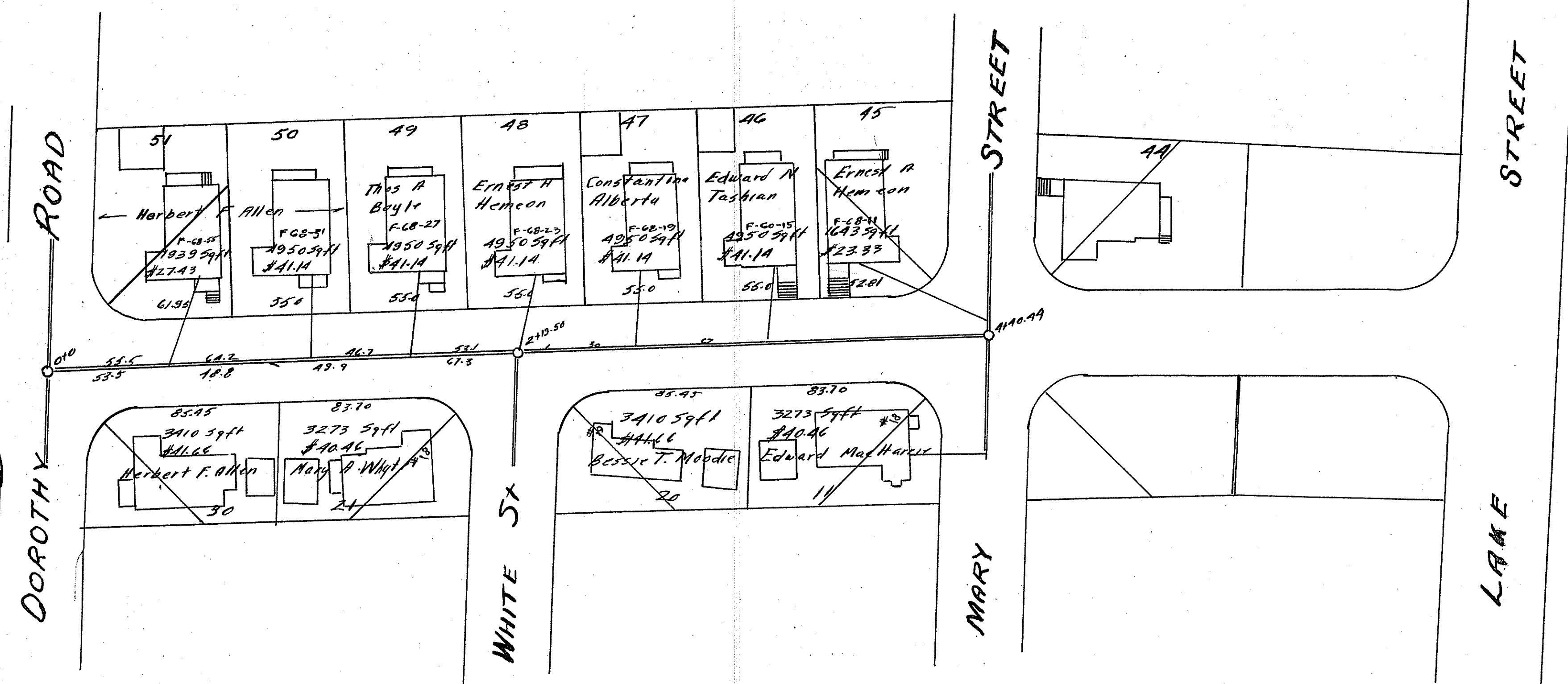

SEWER ASSESSMENT PLAN
 No 436
BURCH STREET
 Hor 1"=40'
 Scales Ver 1"=6'
 Geo E Ahern Town Engineer
 Nov. 7, 1927
 NOTE: (Stations changed) *from Sta 0+0 to Sta 2+19.50 installed in 1929

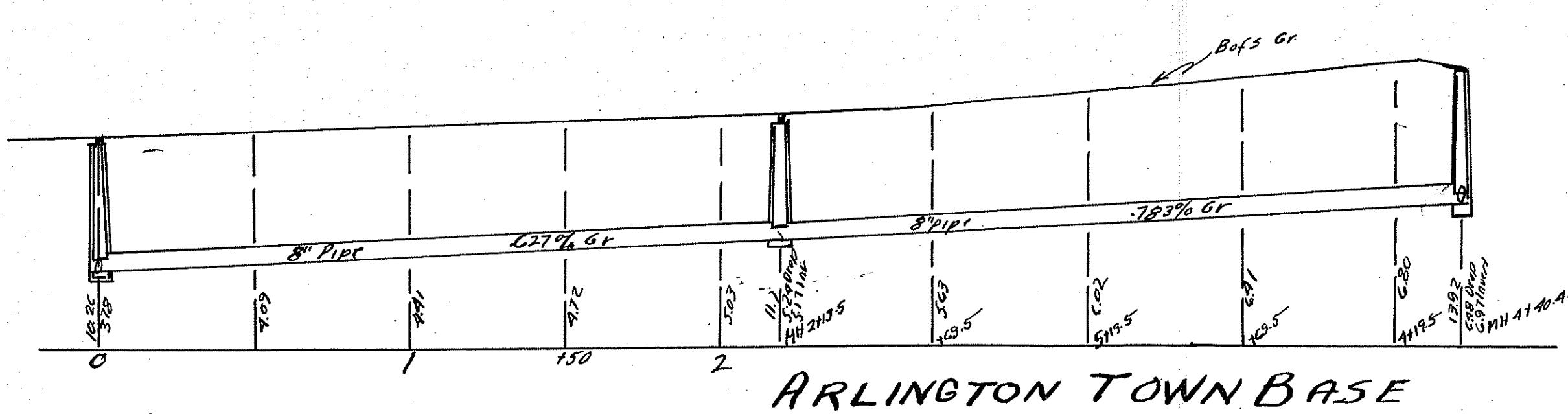

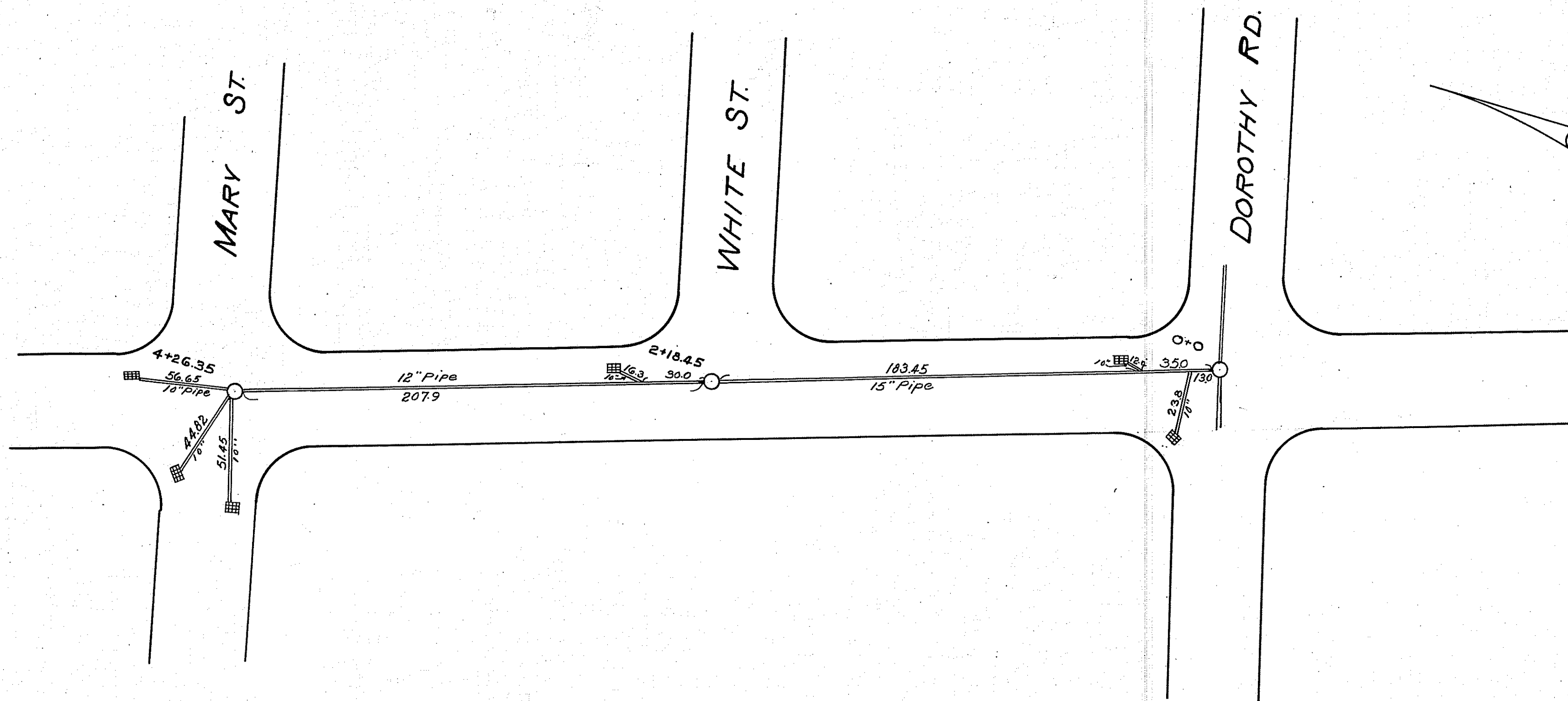

PLAN AND PROFILE
OF
STORM DRAIN
IN
BURCH STREET
Hor 1"=40'
Scales Ver 1"=6'
 James M. Keane *Town Engineer*
 Jan. 15, 1935.

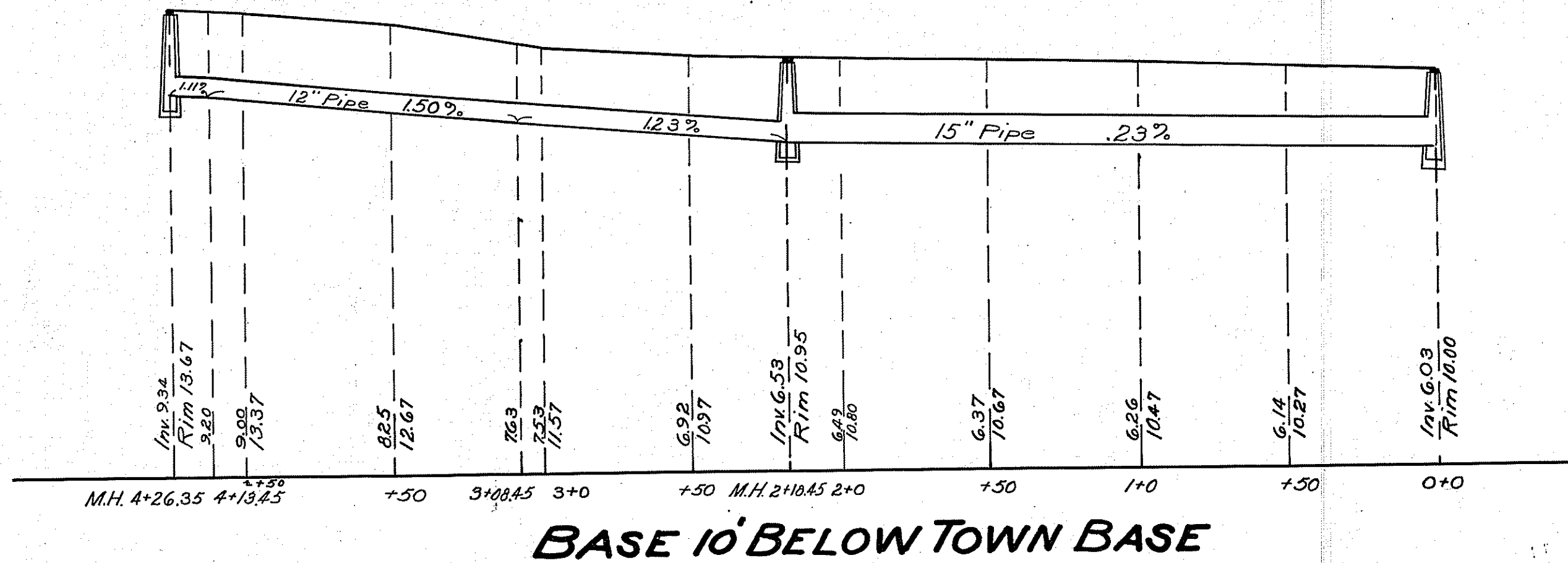

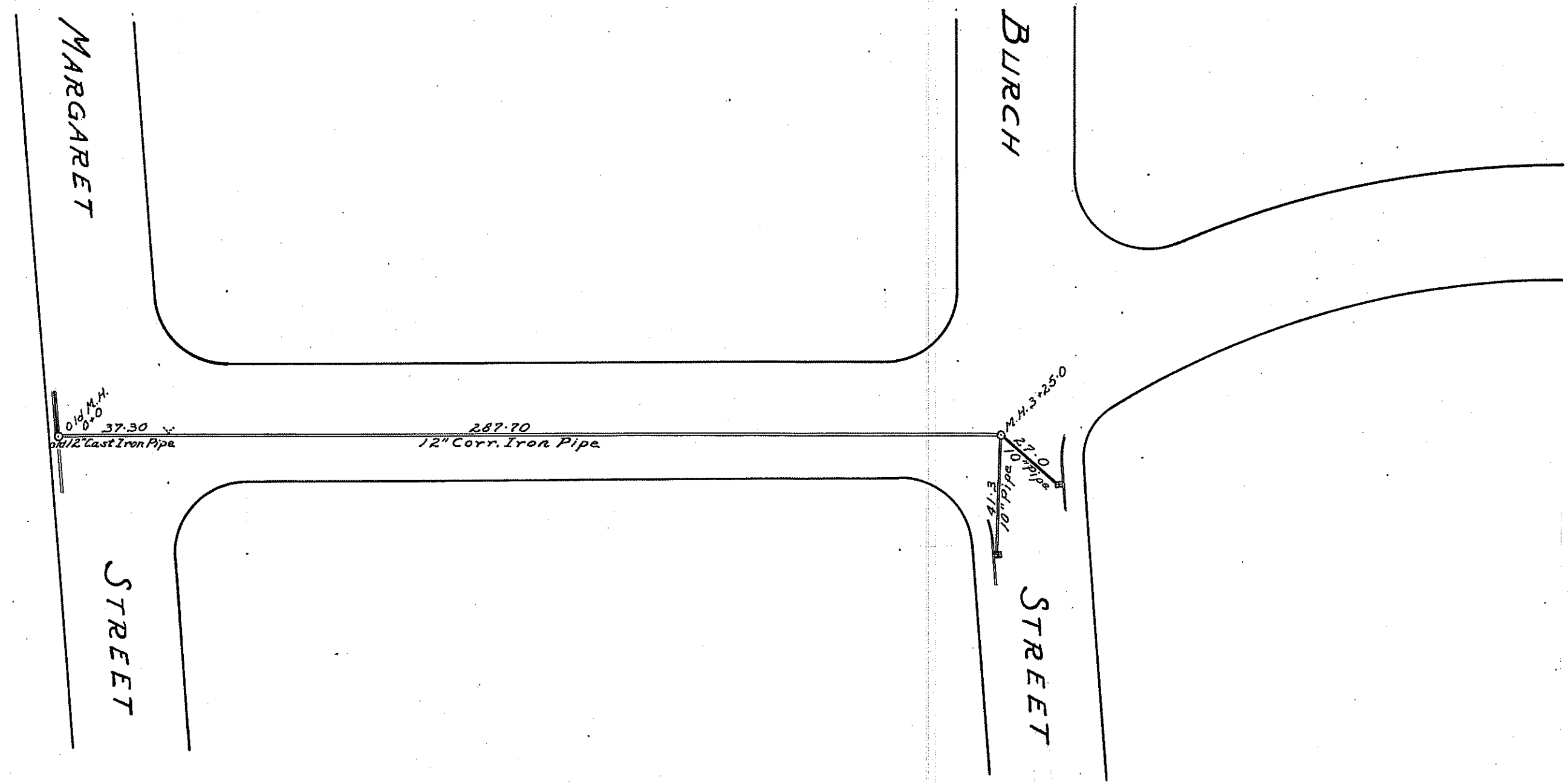

PLAN AND PROFILE
OF
STORM DRAIN
IN
EDITH STREET
ARLINGTON - MASS.

Scales { Hor. 1" = 40'
Vert. 1" = 6' Feb. 1952

James M. Keane - Town Eng'r.

