

BID DOCUMENTS AND SPECIFICATIONS FOR:

**Peirce School Playground Renovation
Arlington, Massachusetts**

Bid # 19-40

July 2019

Prepared for:

Town of Arlington, Massachusetts

Prepared by: Weston & Sampson Engineers, Inc.

SEALED BIDS will be received:

Date: August 22, 2019

Time: 10:00 AM

Place: Office of the Purchasing Agent

730 Massachusetts Avenue

Arlington, MA 02476

**Town of Arlington
Massachusetts**

INVITATION TO BID

BID No. 19- 40 Pierce School Playground Renovation

Sealed bids for Pierce School Playground Renovation for the Town of Arlington, MA, will be received at the Purchasing Department, 730 Mass Ave. Arlington, MA 02476 until **10:00AM EST on Thursday August 22, 2019** at which time and place said bids will be publicly opened and read aloud.

All bids must be in a sealed envelope plainly marked: BID No. 19-40 Pierce School Playground Renovation

The scope of work includes furnishing all labor, materials, and equipment necessary to make improvements to the Newland Road Playground at Peirce Elementary School by demolition and site preparation as described in the Contract Drawings and installing new concrete walkways, fencing, site furniture, play equipment, safety surfacing, and landscape areas.

Contract documents are available on the Town website at arlingtonma.gov/purchasing.

Questions may be addressed to the Designer until 4:00 pm on August 12th. Contractors should have visited the site at their convenience prior to submitting questions. A written addendum answering questions will be issued if necessary before August 15th at 4:00pm. There is no pre-bid meeting for this project.

The Designer is Weston & Sampson, c/o Amanda Gaal: gaala@wseinc.com

The project is to begin as soon as a contract is executed. The project completion date is Friday, November 22, 2019.

A bid deposit in the amount of five percent (5%) on the Bid amount, including any and all alternates, shall be submitted with each Bid. Bid deposit shall be in the form of Certified Check, or a Treasurer's or Cashier's Check issued by a responsible or trust company payable to the Town of Arlington or a bid bond (a) in a form satisfactory to the Awarding Authority, (b) with a surety company qualified to do business in the Commonwealth of Massachusetts and (c) conditioned upon faithful performance by the principal of the agreements contained in the Bid. Return of bid deposits will be in accordance with the provisions of the applicable General Laws. All bid bonds shall be retained by the Town of Arlington unless accompanied by a stamped, self-addressed envelope.

Bidding procedures and award of the contract shall be in accordance with the applicable provisions of the Commonwealth of Massachusetts General Laws, Chapter 30, Section 39M as amended and Chapter 149, Sections 44A through 44L, inclusive, as amended.

The Town of Arlington will reject any Bid when required to do so by the above referenced General Laws. In addition, the Town of Arlington reserves the right to waive any informality in bidding and to reject any and all bids if it deems it to be the public interest to do so.

The successful bidder will be required to furnish a Performance Bond and a Labor and Materials Payment bond, each in the amount of 100% of the Contract Amount. The cost of such bonds, including any and all alternates, shall be stated on the bid form. Such bonds shall be of a surety company qualified to do business under the laws of the commonwealth of Massachusetts.

Bylaw of the Town of Arlington, Title 1, Article 16, Minority/Woman Workforce Participation in Construction Projects which exceed \$200,000 is part and parcel of the bid,

Minimum Wage rates as determined by the Commissioner of the Division of Occupational Safety of the Executive Office of Labor and Workforce Development under the provisions of Chapter 149, Sections 26 to 27D inclusive, as amended, apply to this project. It is the responsibility of the Bidder, before bid opening, to request if necessary, any additional information on Minimum Wage Rates for those trades people who may be employed for the proposed work under this contract.

No bidder may withdraw his bid for a period of sixty (60) days, excluding Saturdays, Sundays and legal holidays, after the actual date of the opening thereof.

The Town of Arlington is exempt from sales tax, for which reason Bidders should not include sales taxes in figuring or in references to any bid.

Commonwealth of Massachusetts General Laws Section 149, Sections 44A through 44L, inclusive and Chapter 30, Sections 39F through 39P inclusive, are incorporated herein by reference. Any inconsistency between the Invitation to Bid, Instructions to Bidders, Bid Forms, Conditions of the Contract and any other contract documents and these Statutes, or any other applicable statutes, bylaws or regulation shall be deemed to govern.

The attention of bidders is particularly called to the requirements as to conditions of employment to be observed, the minimum wage rates to be paid under the contract and affirmative action to ensure equal employment opportunity.

Adam Chapdelaine, Town Manager
TOWN OF ARLINGTON, MASSACHUSETTS
July 31, 2019

INSTRUCTIONS TO BIDDERS

- I. COMPLEMENTARY DOCUMENT
 - A. INVITATION TO BID, including herewith, is complementary to this document and shall be reviewed by bidder for specific instruction which are not repeated herein.

2. STATUTES REGUALTING COMPETITIVE BIDDING
 - A. Bidding procedures and award of general contract and subcontracts shall be in accordance with the provisions of Chapter 30, Section 39M and Chapter 149, Section 44A through 44L inclusive, of the General Laws of the Commonwealth of Massachusetts, including all current amendments.
 - B. In the event of any discrepancy or inconsistency between the provisions of these Bid and Contract Documents and the above-mentioned statutes, the provisions of the above-mentioned statutes shall govern. In such event, the application of all remaining provisions not in conflict to any circumstance other than that in which the conflict occurs shall not be affected thereby.

3. BIDDER'S QUALIFICATIONS
 - A. DCPO Certification not required.
 - B. The Contractors' Update Statements are not public records and will not be open to public inspection.

4. INTERPRETATION OF DOCUMENTS: NOTIFICATION OF ERRORS
 - A. Interpretations of the provisions of the Bid and Contract Documents will be made by the designer upon written request of any general bidder or subbidder, provided that such request is received by the Designer at least seven (7) days prior to the date of the applicable bid opening, and that the Designer considers such interpretation to be of sufficient importance. Oral or telephone interpretations will not generally be made, and if made shall be strictly informal and not legally valid or binding.
 - B. Such written interpretations shall be in the form of Addenda to the Bid and Contract Documents.
 - C. Bidders are urged to communicate all errors and discrepancies found in the Bid and Contract Documents to the Designer. Telephone calls pointing out any such errors or discrepancies will be taken by the Designer, but only for the purpose of receiving the information in order that it may be properly processed, and not for interpretation or clarification.

5. EXAMINATION OF BIDDING AND CONTRACT DOCUMENTS
 - A. Each Bidder shall carefully examine the Bid and Contract Documents to obtain a thorough understanding of the work of his bid in addition to the work of related trades. In addition, each General Bidder shall personally visit the

site to thoroughly acquaint himself/herself with the conditions as they exist hereon.

- B. Failure of any Bidder to thoroughly examine the Bid and Contract Documents or to visit and examine the site shall in no way relieve him/her of any obligation with respect to his/her bid or of any responsibility assigned to him under the Contract.

6. PRE-BID CONFERENCE

- A. Pre-bid conference will be held at the location and time stipulated in the Invitation to Bid.

7. MODIFICATION AND WITHDRAWAL OF BIDS

- A. Modification of withdrawal of Bids will be permitted after the submission of such bids provided clearly written, readily understandable instructions for same are received by the Owner in writing prior to the time established for opening of such bids. No Bid may be withdrawn after that time, except as otherwise provided herein or by law.

8. ADDENDA

- A. Addenda may be required during the bidding period to modify, clarify or interpret the Bid and Contract Documents. It is intended, but not guaranteed, that such Addenda shall be mailed by the Owner to all persons or parties to whom Bid and Contract Documents have been issued (Bidders of Record). Failure to receive such Addenda shall in no way relieve any bidder from the execution of its provisions. All bidders are cautioned to verify the number of Addenda which have been issued and to secure any needed copies from the Designer before submitting a Bid.

9. FORM FOR BIDS

- A. The Owner will make available, to every person applying therefor, a Bid Form. Each bona fide Bidder will be furnished forms for his proposal upon request. Such forms will be made available at the Owner's office during the regular office hours throughout the bidding period. Bids must be submitted on the forms provided by Owner or of forms included in the bid documents of the Project Manual.
- B. All blank spaces provided on the bid forms shall be filled in with ink or typewriter. Where space is provided, sums shall be expressed in both words and figures. In case of a discrepancy between the two, the written words shall govern.
- C. No interlineations, additional, alterations or erasures shall be made on the forms.

10. ALTERNATES

- A. Each Bidder shall bid on alternatives listed. In the event that any alternate does not involve a change in the amount of the Bid, the Bidder shall so

indicate by using the words "No Change" in the space provided for that alternate.

- B. General Bidders shall enter on the form for General Bid a single amount for each alternate, each amount to consist of the total of all the subbidders' amounts for the given alternate plus the amount of for work of the alternate to be performed by the General Contractor.
- C. If alternate(s) are accepted, they shall be accepted in the order listed. The low bidder will be determined on the basis of the sum of the Base Bid and the alternates accepted.

11. SUBMISSION OF BIDS

- A. The Bid Form shall be properly executed and enclosed with the required bid deposit in a sealed envelope plainly marked on the outside with the following information.

Bid For:

SUBMITTED
BY:

(Name of Bidder)

(Address of Bidder)

- B. If Bids are mailed; the above required envelope shall be enclosed in a second envelope identified with the above markings and mailed to the place of bid opening, as described in the Invitation to Bid. Mailed Bids must be received before the time scheduled for opening of Bids.

12. PERFORMANCE AND PAYMENT BONDS

- A. The Performance and Labor and Materials Payment Bonds required of the General Contractor shall each be in the amount of 100% of the contract sum from a surety company qualified to do business under the laws of the Commonwealth of Massachusetts and approved by the Owner.

13. FOREIGN CORPORATIONS

- A. The attention of bidders is called to General Laws, Chapter 30, Section 39L, as amended by Acts of 1967, Chapter 3, under which the Owner may not enter into a contract with a foreign corporation as a subcontractor unless the foreign corporation has filed with the Owner a certificate by the State Secretary stating that the foreign corporation has complied with General Laws Chapter 181, Sections 3 and 5 and stating the date of such compliance.

14. AWARD OF CONTRACT

- A. The Contract will be awarded to the lowest responsible and eligible bidder except in the event of a substitution as provided by under Chapter 149, Sections 44E and 44F of the above-reference General Laws.

15. COMMENCEMENT AND COMPLETION OF WORK

- A. The successful bidder, upon completion of the Contract Agreement, shall commence the work of the Contract within seven (7) calendar days from receipt of written Notice to Proceed issued by the Owner within fourteen (14) calendar days after said execution of the Contract Agreement, and shall therefore diligently and continuously carry on the work in such manner as to substantially complete the work on or before November 22, 2019 except as noted herein.

16. LIQUIDATED DAMAGES

- A. The attention of bidders is particularly called to the requirements as to the conditions of employment to be observed, the minimum wage rates to be paid under the Contract and affirmative action to ensure equal employment opportunity.
- B. Contractor shall make full good faith efforts to secure at least ten percent (10%) of the Labor and Materials incorporated in the Work from Minority Business Enterprises and five percent (5%) of the Labor and Materials incorporated in the Work from Women Business Enterprises certified by the Commonwealth of Massachusetts and consistent with the Federal Equal Employment Opportunity requirements attached hereto as Attachment A. Satisfactory documentation of such effort shall be furnished promptly upon request by Owner.
- C. The Owner is an equal employment opportunity employer and has an active Affirmative Action Plan (AAP). For more information, direct correspondence to Patricia M. Libby, Affirmative Action Officer for the Town of Arlington.

BID FORM

For: Peirce School Playground Renovation (Bid #19-40)

Proposal (BID) of _____
(hereinafter called "Bidder") a corporation, organized and existing under the laws of the
Commonwealth of Massachusetts.

_____ doing business as _____
(corporation, proprietorship, partnership)

to the TOWN OF ARLINGTON hereinafter called "Owner". Gentlemen:

- A. The Bidder, in compliance with your invitation for bids for the Peirce Playground Renovation, Arlington Massachusetts, having examined the plan and specifications with related documents and the site of the proposed project including the availability of materials and labor, hereby proposes to furnish all labor, materials and supplies, and to construct the project in accordance with the Contract Documents, within the time set forth therein, and at the prices stated below. These prices are to cover all expenses incurred in performing the work required under the Contract Documents, of which this proposal is a part.

Bidder hereby agrees to commence work under this Contract on or before a date to be specified in the written "Notice to Proceed" from the Owner, and to complete the work by November 22, 2019. The Bidder further agrees to pay as liquidated damages, the sum of \$100.00 for each consecutive calendar day thereafter that the work remains incomplete, as provided in the Instruction to Bidders, Modifications to General Conditions. Required completion dates are as follows:

- B. Bidder acknowledges receipt of the following addendum:

_____ Dated _____
_____ Dated _____
_____ Dated _____

- C. Bidder agrees to perform all work described in the specifications and shown on the drawings, for the following lump sum price of:

- 1. Total Proposed Base Bid Contract Price:

_____ Dollars (\$ _____)

- 2. Bid Deposit on total bid price, in the sum of:

_____ Dollars (\$ _____) in

the form of _____ is submitted herewith in accordance with the INSTRUCTION FOR BIDDERS and is to become property of the Owner in the event the Contract and bonds are not executed within the time above set forth, as liquidated

damages for the delay and additional expense to the Owner caused thereby.

- 3. The Bid does not include premiums on Performance/Labor and Materials Bond. Cost of required Bond Premiums (for base bid and any and all alternates):

Bond Premiums Add \$ _____

- 4. Alternates _____ N/A

- D. If the Bid is accepted by the Owner, the undersigned agrees to complete the entire work provided to be done under the contract within the time stipulated by the Owner.
- E. The undersigned agrees that for extra work, if any, performed in accordance with the AGREEMENT, he will accept compensation as stipulated therein in full payment for such extra work.
- F. Bidder understands that the Owner reserves the right to reject any and all bids.
- G. The undersigned hereby agrees that he will not withdraw the Bid within sixty (60) consecutive calendar days after the actual date of the opening of Bids and that, if the Owner accepts this Bid, the undersigned will duly execute and acknowledge the required Contract Bonds within 10 days after notification that the AGREEMENT is ready for signature.
- H. Should the undersigned fail to fulfill any of his agreements as here in before set forth, the Owner shall have the right to retain as liquidated damages the amount of the Bid security, which shall become the Owner/s property. If a bid was furnished as bid security, it is agreed that the amount thereof shall be paid as liquidated damages to the Owner by the Surety.
- I. The Undersigned certifies under penalty of perjury that this Bid is in all respect bona fide, fair and made without collusion or fraud with any other person. As used in this subsection the "person" shall men natural person, joint venture, partnership, corporation or other business or legal entity.
- J. The undersigned certifies that he is able to furnish labor that can work in harmony with all with all laws and regulations applicable to awards made subject forty-four A.
 - 1. Have been in business under the present name for _____ years.
 - 2. Ever failed to complete any work awarded? _____(Yes), _____(No). If yes, explain: _____
 - 3. Bank Reference: _____

K. The Bidder is required to state below all work he/she and his/her subcontractors (if subcontractors are to perform substantial portions of the work) has compete within the past 5 years of a similar character and value to that of the work included in the proposed Contract and to give references that will enable the Owners to judge the Bidder's experience, skill and business standing. The Bidder is required to list a minimum of 3 completed projects that are comparable in scope, complexity and value. For each project, include the name, location, type, date complete, construction value and owner contact.

(add supplementary page if necessary)

L. The Bidder is required to state below all construction projects he/she currently has under contract. For each project, include the name, location, type, scheduled completion date, construction value and owner contact.

M. The undersigned bidder hereby certifies that the tools and equipment required to meet the specified requirements of the Contract document, will be utilized in the performance of the work.

- N. The undersigned further certifies under the penalty of perjury that the said undersigned is not presently debarred from doing public construction work in the Commonwealth of Massachusetts under the provisions of section 29F, or any other applicable debarment provisions of any other chapter of the General Laws or any rule or regulation declared there under.

- O. The undersigned bidder hereby certifies he/she will comply with the minority workforce percentage ratio and specific affirmative action steps contained in the EEO/AA provisions of the Contract, including compliance with Minority/Women Business Enterprise as required under these contract provisions. The contractor receiving the award of the Contract shall be required to obtain from each of its subcontractors a copy of its bidder's certification and submit it to the contracting agency prior to the award of such subcontract, regardless of tier, that it will comply with the minority workforce ratio and specific affirmative action steps contained in these EEO/AA contract provisions.

Date: _____

Name of General Bidder

By:

Name and Title of Person Signing Bond

Business Address

To view and print Weekly Payroll & Statement of Compliance Forms, click on www.mass.gov/dols/pw.

PLEASE NOTE: The attached Prevailing Wage Schedule is valid for 90 days. An Awarding Authority should re-request an up to date Prevailing Wage Schedule if it has NOT opened bids or selected a contractor within 90 days of the issuance date of the attached prevailing wage schedule.

*For MULTI-YEAR projects bid on or after 8/8/08, Awarding Authorities must request an Annual Update to this Prevailing Wage Schedule each year for the duration of the project, no later than two weeks before the anniversary date of the execution of the general contract. Annual updates are not required for projects that last LESS THAN ONE YEAR.

*For CM AT RISK projects (bid pursuant to GL c.149A), Awarding Authorities must request a Prevailing Wage Schedule NOT sooner than 90-days before the earlier of: (a) the execution date of the GMP Amendment, or (b) the bid for the first construction scope of work.

*For MULTI-YEAR CM AT RISK projects, Awarding Authorities must request an Annual Update to this Prevailing Wage Schedule each year for the duration of the project, no later than two weeks before the anniversary date, which is the earlier of: (a) the execution date of the GMP Amendment, or (b) the execution date of the first amendment to procure construction scopes of work.

Apprentice wages (expressed as dollar figures) and the required benefits are listed on the Prevailing Wage Schedule. For further details, please see opinion letter PW-2010-03-03.16.10 (dated March 18, 2010) at www.mass.gov/dols/pw.

Request Prevailing Wage Rates online at: www.mass.gov/dols/pw.

THIS IS A SYSTEM-GENERATED EMAIL. PLEASE DO NOT REPLY TO THIS EMAIL. TO CONTACT DLS REGARDING PREVAILING WAGE MATTERS, CALL 617-626-6953.

=====

APPROVAL/DENIAL COMMENTS



**THE COMMONWEALTH OF MASSACHUSETTS
EXECUTIVE OFFICE OF LABOR AND WORKFORCE DEVELOPMENT
DEPARTMENT OF LABOR STANDARDS**

Prevailing Wage Rates

**As determined by the Director under the provisions of the
Massachusetts General Laws, Chapter 149, Sections 26 to 27H**

CHARLES D. BAKER
Governor

ROSALIN ACOSTA
Secretary

KARYN E. POLITO
Lt. Governor

WILLIAM D MCKINNEY
Director

Awarding Authority: Town of Arlington
Contract Number: 19-40 **City/Town:** ARLINGTON
Description of Work: Peirce School Playground Renovation including removal of existing play surfacing and equipment, installation of new site surfacing, play surfacing, play equipment, landscaping and site amenities.
Job Location: Park Ave Ext.

Information about Prevailing Wage Schedules for Awarding Authorities and Contractors

- This wage schedule applies only to the specific project referenced at the top of this page and uniquely identified by the “Wage Request Number” on all pages of this schedule.
- An Awarding Authority must request an updated wage schedule from the Department of Labor Standards (“DLS”) if it has not opened bids or selected a contractor within 90 days of the date of issuance of the wage schedule. For CM AT RISK projects (bid pursuant to G.L. c.149A), the earlier of: (a) the execution date of the GMP Amendment, or (b) the bid for the first construction scope of work must be within 90-days of the wage schedule issuance date.
- The wage schedule shall be incorporated in any advertisement or call for bids for the project as required by M.G.L. c. 149, § 27. The wage schedule shall be made a part of the contract awarded for the project. The wage schedule must be posted in a conspicuous place at the work site for the life of the project in accordance with M.G.L. c. 149 § 27. The wages listed on the wage schedule must be paid to employees performing construction work on the project whether they are employed by the prime contractor, a filed sub-bidder, or any sub-contractor.
- All apprentices working on the project are required to be registered with the Massachusetts Department of Labor Standards, Division of Apprentice Standards (DLS/DAS). Apprentice must keep his/her apprentice identification card on his/her person during all work hours on the project. An apprentice registered with DAS may be paid the lower apprentice wage rate at the applicable step as provided on the prevailing wage schedule. **Any apprentice not registered with DLS/DAS regardless of whether or not they are registered with any other federal, state, local, or private agency must be paid the journeyworker's rate for the trade.**
- The wage rates will remain in effect for the duration of the project, except in the case of multi-year public construction projects. For construction projects lasting longer than one year, awarding authorities must request an updated wage schedule. Awarding authorities are required to request these updates no later than two weeks before the anniversary of the date the contract was executed by the awarding authority and the general contractor. For multi-year CM AT RISK projects, awarding authority must request an annual update no later than two weeks before the anniversary date, determined as the earlier of: (a) the execution date of the GMP Amendment, or (b) the execution date of the first amendment to permit procurement of construction services. Contractors are required to obtain the wage schedules from awarding authorities, and to pay no less than these rates to covered workers. The annual update requirement is not applicable to 27F “rental of equipment” contracts.
- Every contractor or subcontractor which performs construction work on the project is required to submit weekly payroll reports and a Statement of Compliance directly to the awarding authority by mail or email and keep them on file for three years. Each weekly payroll report must contain: the employee’s name, address, occupational classification, hours worked, and wages paid. Do not submit weekly payroll reports to DLS. A sample of a payroll reporting form may be obtained at <http://www.mass.gov/dols/pw>.
- Contractors with questions about the wage rates or classifications included on the wage schedule have an affirmative obligation to inquire with DLS at (617) 626-6953.
- Employees not receiving the prevailing wage rate set forth on the wage schedule may report the violation to the Fair Labor Division of the office of the Attorney General at (617) 727-3465.
- Failure of a contractor or subcontractor to pay the prevailing wage rates listed on the wage schedule to all employees who perform construction work on the project is a violation of the law and subjects the contractor or subcontractor to civil and

Classification	Effective Date	Base Wage	Health	Pension	Supplemental Unemployment	Total Rate
Construction						
(2 AXLE) DRIVER - EQUIPMENT <i>TEAMSTERS JOINT COUNCIL NO. 10 ZONE A</i>	06/01/2019	\$35.35	\$11.91	\$12.70	\$0.00	\$59.96
	08/01/2019	\$35.35	\$12.41	\$12.70	\$0.00	\$60.46
	12/01/2019	\$35.35	\$12.41	\$13.72	\$0.00	\$61.48
	06/01/2020	\$36.25	\$12.41	\$13.72	\$0.00	\$62.38
	08/01/2020	\$36.25	\$12.91	\$13.72	\$0.00	\$62.88
	12/01/2020	\$36.25	\$12.91	\$14.82	\$0.00	\$63.98
	06/01/2021	\$37.05	\$12.91	\$14.82	\$0.00	\$64.78
	08/01/2021	\$37.05	\$13.41	\$14.82	\$0.00	\$65.28
	12/01/2021	\$37.05	\$13.41	\$16.01	\$0.00	\$66.47
(3 AXLE) DRIVER - EQUIPMENT <i>TEAMSTERS JOINT COUNCIL NO. 10 ZONE A</i>	06/01/2019	\$35.42	\$11.91	\$12.70	\$0.00	\$60.03
	08/01/2019	\$35.42	\$12.41	\$12.70	\$0.00	\$60.53
	12/01/2019	\$35.42	\$12.41	\$13.72	\$0.00	\$61.55
	06/01/2020	\$36.32	\$12.41	\$13.72	\$0.00	\$62.45
	08/01/2020	\$36.32	\$12.91	\$13.72	\$0.00	\$62.95
	12/01/2020	\$36.32	\$12.91	\$14.82	\$0.00	\$64.05
	06/01/2021	\$37.12	\$12.91	\$14.82	\$0.00	\$64.85
	08/01/2021	\$37.12	\$13.41	\$14.82	\$0.00	\$65.35
	12/01/2021	\$37.12	\$13.41	\$16.01	\$0.00	\$66.54
(4 & 5 AXLE) DRIVER - EQUIPMENT <i>TEAMSTERS JOINT COUNCIL NO. 10 ZONE A</i>	06/01/2019	\$35.54	\$11.91	\$12.70	\$0.00	\$60.15
	08/01/2019	\$35.54	\$12.41	\$12.70	\$0.00	\$60.65
	12/01/2019	\$35.54	\$12.41	\$13.72	\$0.00	\$61.67
	06/01/2020	\$36.44	\$12.41	\$13.72	\$0.00	\$62.57
	08/01/2020	\$36.44	\$12.91	\$13.72	\$0.00	\$63.07
	12/01/2020	\$36.44	\$12.91	\$14.82	\$0.00	\$64.17
	06/01/2021	\$37.24	\$12.91	\$14.82	\$0.00	\$64.97
	08/01/2021	\$37.24	\$13.41	\$14.82	\$0.00	\$65.47
	12/01/2021	\$37.24	\$13.41	\$16.01	\$0.00	\$66.66
ADS/SUBMERSIBLE PILOT <i>PILE DRIVER LOCAL 56 (ZONE 1)</i>	08/01/2018	\$97.80	\$9.90	\$21.15	\$0.00	\$128.85
	08/01/2019	\$102.78	\$9.90	\$21.15	\$0.00	\$133.83
For apprentice rates see "Apprentice- PILE DRIVER"						
AIR TRACK OPERATOR <i>LABORERS - ZONE 1</i>	06/01/2019	\$39.90	\$7.85	\$15.85	\$0.00	\$63.60
	12/01/2019	\$40.90	\$7.85	\$15.85	\$0.00	\$64.60
	06/01/2020	\$41.89	\$7.85	\$15.85	\$0.00	\$65.59
	12/01/2020	\$42.87	\$7.85	\$15.85	\$0.00	\$66.57
	06/01/2021	\$43.89	\$7.85	\$15.85	\$0.00	\$67.59
	12/01/2021	\$44.90	\$7.85	\$15.85	\$0.00	\$68.60
For apprentice rates see "Apprentice- LABORER"						
ASBESTOS REMOVER - PIPE / MECH. EQUIPT. <i>HEAT & FROST INSULATORS LOCAL 6 (BOSTON)</i>	06/01/2019	\$36.40	\$12.50	\$8.50	\$0.00	\$57.40
	12/01/2019	\$37.40	\$12.50	\$8.50	\$0.00	\$58.40
	06/01/2020	\$38.40	\$12.50	\$8.50	\$0.00	\$59.40
	12/01/2020	\$39.40	\$12.50	\$8.50	\$0.00	\$60.40

Classification	Effective Date	Base Wage	Health	Pension	Supplemental Unemployment	Total Rate
ASPHALT RAKER <i>LABORERS - ZONE 1</i>	06/01/2019	\$39.40	\$7.85	\$15.85	\$0.00	\$63.10
	12/01/2019	\$40.40	\$7.85	\$15.85	\$0.00	\$64.10
	06/01/2020	\$41.39	\$7.85	\$15.85	\$0.00	\$65.09
	12/01/2020	\$42.37	\$7.85	\$15.85	\$0.00	\$66.07
	06/01/2021	\$43.39	\$7.85	\$15.85	\$0.00	\$67.09
	12/01/2021	\$44.40	\$7.85	\$15.85	\$0.00	\$68.10
For apprentice rates see "Apprentice- LABORER"						
ASPHALT/CONCRETE/CRUSHER PLANT-ON SITE <i>OPERATING ENGINEERS LOCAL 4</i>	06/01/2019	\$48.18	\$12.00	\$15.60	\$0.00	\$75.78
	12/01/2019	\$49.33	\$12.00	\$15.60	\$0.00	\$76.93
	06/01/2020	\$50.43	\$12.00	\$15.60	\$0.00	\$78.03
	12/01/2020	\$51.58	\$12.00	\$15.60	\$0.00	\$79.18
	06/01/2021	\$52.68	\$12.00	\$15.60	\$0.00	\$80.28
	12/01/2021	\$53.83	\$12.00	\$15.60	\$0.00	\$81.43
For apprentice rates see "Apprentice- OPERATING ENGINEERS"						
BACKHOE/FRONT-END LOADER <i>OPERATING ENGINEERS LOCAL 4</i>	06/01/2019	\$48.18	\$12.00	\$15.60	\$0.00	\$75.78
	12/01/2019	\$49.33	\$12.00	\$15.60	\$0.00	\$76.93
	06/01/2020	\$50.43	\$12.00	\$15.60	\$0.00	\$78.03
	12/01/2020	\$51.58	\$12.00	\$15.60	\$0.00	\$79.18
	06/01/2021	\$52.68	\$12.00	\$15.60	\$0.00	\$80.28
	12/01/2021	\$53.83	\$12.00	\$15.60	\$0.00	\$81.43
For apprentice rates see "Apprentice- OPERATING ENGINEERS"						
BARCO-TYPE JUMPING TAMPER <i>LABORERS - ZONE 1</i>	06/01/2019	\$39.40	\$7.85	\$15.85	\$0.00	\$63.10
	12/01/2019	\$40.40	\$7.85	\$15.85	\$0.00	\$64.10
	06/01/2020	\$41.39	\$7.85	\$15.85	\$0.00	\$65.09
	12/01/2020	\$42.37	\$7.85	\$15.85	\$0.00	\$66.07
	06/01/2021	\$43.39	\$7.85	\$15.85	\$0.00	\$67.09
	12/01/2021	\$44.40	\$7.85	\$15.85	\$0.00	\$68.10
For apprentice rates see "Apprentice- LABORER"						
BLOCK PAVER, RAMMER / CURB SETTER <i>LABORERS - ZONE 1</i>	06/01/2019	\$39.90	\$7.85	\$15.85	\$0.00	\$63.60
	12/01/2019	\$40.90	\$7.85	\$15.85	\$0.00	\$64.60
	06/01/2020	\$41.89	\$7.85	\$15.85	\$0.00	\$65.59
	12/01/2020	\$42.87	\$7.85	\$15.85	\$0.00	\$66.57
	06/01/2021	\$43.89	\$7.85	\$15.85	\$0.00	\$67.59
	12/01/2021	\$44.90	\$7.85	\$15.85	\$0.00	\$68.60
For apprentice rates see "Apprentice- LABORER"						
BOILER MAKER <i>BOILERMAKERS LOCAL 29</i>	01/01/2019	\$44.71	\$7.07	\$17.72	\$0.00	\$69.50
	01/01/2020	\$46.10	\$7.07	\$17.98	\$0.00	\$71.15

Classification

Effective Date Base Wage Health Pension Supplemental Unemployment Total Rate

Apprentice - BOILERMAKER - Local 29

Effective Date - 01/01/2019

Step	percent	Apprentice Base Wage	Health	Pension	Supplemental Unemployment	Total Rate
1	65	\$29.06	\$7.07	\$11.52	\$0.00	\$47.65
2	65	\$29.06	\$7.07	\$11.52	\$0.00	\$47.65
3	70	\$31.30	\$7.07	\$12.40	\$0.00	\$50.77
4	75	\$33.53	\$7.07	\$13.30	\$0.00	\$53.90
5	80	\$35.77	\$7.07	\$14.18	\$0.00	\$57.02
6	85	\$38.00	\$7.07	\$15.07	\$0.00	\$60.14
7	90	\$40.24	\$7.07	\$15.95	\$0.00	\$63.26
8	95	\$42.47	\$7.07	\$16.84	\$0.00	\$66.38

Effective Date - 01/01/2020

Step	percent	Apprentice Base Wage	Health	Pension	Supplemental Unemployment	Total Rate
1	65	\$29.97	\$7.07	\$11.69	\$0.00	\$48.73
2	65	\$29.97	\$7.07	\$11.69	\$0.00	\$48.73
3	70	\$32.27	\$7.07	\$12.59	\$0.00	\$51.93
4	75	\$34.58	\$7.07	\$13.49	\$0.00	\$55.14
5	80	\$36.88	\$7.07	\$14.38	\$0.00	\$58.33
6	85	\$39.19	\$7.07	\$15.29	\$0.00	\$61.55
7	90	\$41.49	\$7.07	\$16.18	\$0.00	\$64.74
8	95	\$43.80	\$7.07	\$17.09	\$0.00	\$67.96

Notes:

Apprentice to Journeyworker Ratio:1:4

BRICK/STONE/ARTIFICIAL MASONRY (INCL. MASONRY WATERPROOFING)	02/01/2019	\$53.55	\$10.75	\$20.66	\$0.00	\$84.96
BRICKLAYERS LOCAL 3 (BOSTON)	08/01/2019	\$54.40	\$10.75	\$21.30	\$0.00	\$86.45
	02/01/2020	\$55.04	\$10.75	\$21.30	\$0.00	\$87.09
	08/01/2020	\$56.39	\$10.75	\$21.45	\$0.00	\$88.59
	02/01/2021	\$57.03	\$10.75	\$21.45	\$0.00	\$89.23
	08/01/2021	\$58.43	\$10.75	\$21.61	\$0.00	\$90.79
	02/01/2022	\$59.02	\$10.75	\$21.61	\$0.00	\$91.38

Classification

Effective Date Base Wage Health Pension Supplemental Unemployment Total Rate

Apprentice - BRICK/PLASTER/CEMENT MASON - Local 3 Boston

Effective Date - 02/01/2019

Step	percent	Apprentice Base Wage	Health	Pension	Supplemental Unemployment	Total Rate
1	50	\$26.78	\$10.75	\$20.66	\$0.00	\$58.19
2	60	\$32.13	\$10.75	\$20.66	\$0.00	\$63.54
3	70	\$37.49	\$10.75	\$20.66	\$0.00	\$68.90
4	80	\$42.84	\$10.75	\$20.66	\$0.00	\$74.25
5	90	\$48.20	\$10.75	\$20.66	\$0.00	\$79.61

Effective Date - 08/01/2019

Step	percent	Apprentice Base Wage	Health	Pension	Supplemental Unemployment	Total Rate
1	50	\$27.20	\$10.75	\$21.30	\$0.00	\$59.25
2	60	\$32.64	\$10.75	\$21.30	\$0.00	\$64.69
3	70	\$38.08	\$10.75	\$21.30	\$0.00	\$70.13
4	80	\$43.52	\$10.75	\$21.30	\$0.00	\$75.57
5	90	\$48.96	\$10.75	\$21.30	\$0.00	\$81.01

Notes:

Apprentice to Journeyworker Ratio:1:5

BULLDOZER/GRADER/SCRAPER	06/01/2019	\$47.69	\$12.00	\$15.60	\$0.00	\$75.29
<i>OPERATING ENGINEERS LOCAL 4</i>	12/01/2019	\$48.83	\$12.00	\$15.60	\$0.00	\$76.43
	06/01/2020	\$49.91	\$12.00	\$15.60	\$0.00	\$77.51
	12/01/2020	\$51.05	\$12.00	\$15.60	\$0.00	\$78.65
	06/01/2021	\$52.14	\$12.00	\$15.60	\$0.00	\$79.74
	12/01/2021	\$53.28	\$12.00	\$15.60	\$0.00	\$80.88

For apprentice rates see "Apprentice- OPERATING ENGINEERS"

CAISSON & UNDERPINNING BOTTOM MAN	06/01/2019	\$40.25	\$7.85	\$16.05	\$0.00	\$64.15
<i>LABORERS - FOUNDATION AND MARINE</i>	12/01/2019	\$41.25	\$7.85	\$16.05	\$0.00	\$65.15
	06/01/2020	\$42.24	\$7.85	\$16.05	\$0.00	\$66.14
	12/01/2020	\$43.22	\$7.85	\$16.05	\$0.00	\$67.12
	06/01/2021	\$44.24	\$7.85	\$16.05	\$0.00	\$68.14
	12/01/2021	\$45.25	\$7.85	\$16.05	\$0.00	\$69.15

For apprentice rates see "Apprentice- LABORER"

CAISSON & UNDERPINNING LABORER	06/01/2019	\$39.10	\$7.85	\$16.05	\$0.00	\$63.00
<i>LABORERS - FOUNDATION AND MARINE</i>	12/01/2019	\$40.10	\$7.85	\$16.05	\$0.00	\$64.00
	06/01/2020	\$41.09	\$7.85	\$16.05	\$0.00	\$64.99
	12/01/2020	\$42.07	\$7.85	\$16.05	\$0.00	\$65.97
	06/01/2021	\$43.09	\$7.85	\$16.05	\$0.00	\$66.99
	12/01/2021	\$44.10	\$7.85	\$16.05	\$0.00	\$68.00

For apprentice rates see "Apprentice- LABORER"

Classification	Effective Date	Base Wage	Health	Pension	Supplemental Unemployment	Total Rate
CAISSON & UNDERPINNING TOP MAN <i>LABORERS - FOUNDATION AND MARINE</i>	06/01/2019	\$39.10	\$7.85	\$16.05	\$0.00	\$63.00
	12/01/2019	\$40.10	\$7.85	\$16.05	\$0.00	\$64.00
	06/01/2020	\$41.09	\$7.85	\$16.05	\$0.00	\$64.99
	12/01/2020	\$42.07	\$7.85	\$16.05	\$0.00	\$65.97
	06/01/2021	\$43.09	\$7.85	\$16.05	\$0.00	\$66.99
	12/01/2021	\$44.10	\$7.85	\$16.05	\$0.00	\$68.00
For apprentice rates see "Apprentice- LABORER"						
CARBIDE CORE DRILL OPERATOR <i>LABORERS - ZONE 1</i>	06/01/2019	\$39.40	\$7.85	\$15.85	\$0.00	\$63.10
	12/01/2019	\$40.40	\$7.85	\$15.85	\$0.00	\$64.10
	06/01/2020	\$41.39	\$7.85	\$15.85	\$0.00	\$65.09
	12/01/2020	\$42.37	\$7.85	\$15.85	\$0.00	\$66.07
	06/01/2021	\$43.39	\$7.85	\$15.85	\$0.00	\$67.09
	12/01/2021	\$44.40	\$7.85	\$15.85	\$0.00	\$68.10
For apprentice rates see "Apprentice- LABORER"						
CARPENTER <i>CARPENTERS -ZONE 2 (Eastern Massachusetts)</i>	03/01/2019	\$42.35	\$9.90	\$17.50	\$0.00	\$69.75

Apprentice - CARPENTER - Zone 2 Eastern MA

Effective Date - 03/01/2019

Step	percent	Apprentice Base Wage	Health	Pension	Supplemental Unemployment	Total Rate
1	50	\$21.18	\$9.90	\$1.73	\$0.00	\$32.81
2	60	\$25.41	\$9.90	\$1.73	\$0.00	\$37.04
3	70	\$29.65	\$9.90	\$12.31	\$0.00	\$51.86
4	75	\$31.76	\$9.90	\$12.31	\$0.00	\$53.97
5	80	\$33.88	\$9.90	\$14.04	\$0.00	\$57.82
6	80	\$33.88	\$9.90	\$14.04	\$0.00	\$57.82
7	90	\$38.12	\$9.90	\$15.77	\$0.00	\$63.79
8	90	\$38.12	\$9.90	\$15.77	\$0.00	\$63.79

Notes:

% Indentured After 10/1/17; 45/45/55/55/70/70/80/80
Step 1&2 \$30.69/ 3&4 \$36.59/ 5&6 \$53.59/ 7&8 \$59.55

Apprentice to Journeyworker Ratio:1:5

CARPENTER WOOD FRAME <i>CARPENTERS -ZONE 2 (Wood Frame)</i>	04/01/2019	\$27.52	\$7.07	\$7.86	\$0.00	\$42.45
	10/01/2019	\$27.95	\$7.07	\$7.86	\$0.00	\$42.88
All Aspects of New Wood Frame Work						

Classification

Effective Date Base Wage Health Pension Supplemental Unemployment Total Rate

Apprentice - CARPENTER (Wood Frame) - Zone 2

Effective Date - 04/01/2019

Step	percent	Apprentice Base Wage	Health	Pension	Supplemental Unemployment	Total Rate
1	60	\$16.51	\$7.07	\$0.00	\$0.00	\$23.58
2	60	\$16.51	\$7.07	\$0.00	\$0.00	\$23.58
3	65	\$17.89	\$7.07	\$7.86	\$0.00	\$32.82
4	70	\$19.26	\$7.07	\$7.86	\$0.00	\$34.19
5	75	\$20.64	\$7.07	\$7.86	\$0.00	\$35.57
6	80	\$22.02	\$7.07	\$7.86	\$0.00	\$36.95
7	85	\$23.39	\$7.07	\$7.86	\$0.00	\$38.32
8	90	\$24.77	\$7.07	\$7.86	\$0.00	\$39.70

Effective Date - 10/01/2019

Step	percent	Apprentice Base Wage	Health	Pension	Supplemental Unemployment	Total Rate
1	60	\$16.77	\$7.07	\$0.00	\$0.00	\$23.84
2	60	\$16.77	\$7.07	\$0.00	\$0.00	\$23.84
3	65	\$18.17	\$7.07	\$7.86	\$0.00	\$33.10
4	70	\$19.57	\$7.07	\$7.86	\$0.00	\$34.50
5	75	\$20.96	\$7.07	\$7.86	\$0.00	\$35.89
6	80	\$22.36	\$7.07	\$7.86	\$0.00	\$37.29
7	85	\$23.76	\$7.07	\$7.86	\$0.00	\$38.69
8	90	\$25.16	\$7.07	\$7.86	\$0.00	\$40.09

Notes:
 % Indentured After 10/1/17; 45/45/55/55/70/70/80/80
 Step 1&2 \$19.45/ 3&4 \$26.96/ 5&6 \$34.19/ 7&8 \$36.95

Apprentice to Journeyworker Ratio:1:5

CEMENT MASONRY/PLASTERING	07/01/2019	\$47.67	\$12.75	\$22.41	\$0.62	\$83.45
BRICKLAYERS LOCAL 3 (BOSTON)	01/01/2020	\$49.07	\$12.75	\$22.41	\$0.62	\$84.85

Classification

Effective Date Base Wage Health Pension Supplemental Unemployment Total Rate

Apprentice - CEMENT MASONRY/PLASTERING - Eastern Mass (Boston)

Effective Date - 07/01/2019

Step	percent	Apprentice Base Wage	Health	Pension	Supplemental Unemployment	Total Rate
1	50	\$23.84	\$12.75	\$15.41	\$0.00	\$52.00
2	60	\$28.60	\$12.75	\$17.41	\$0.62	\$59.38
3	65	\$30.99	\$12.75	\$18.41	\$0.62	\$62.77
4	70	\$33.37	\$12.75	\$19.41	\$0.62	\$66.15
5	75	\$35.75	\$12.75	\$20.41	\$0.62	\$69.53
6	80	\$38.14	\$12.75	\$21.41	\$0.62	\$72.92
7	90	\$42.90	\$12.75	\$22.41	\$0.62	\$78.68

Effective Date - 01/01/2020

Step	percent	Apprentice Base Wage	Health	Pension	Supplemental Unemployment	Total Rate
1	50	\$24.54	\$12.75	\$15.41	\$0.00	\$52.70
2	60	\$29.44	\$12.75	\$17.41	\$0.62	\$60.22
3	65	\$31.90	\$12.75	\$18.41	\$0.62	\$63.68
4	70	\$34.35	\$12.75	\$19.41	\$0.62	\$67.13
5	75	\$36.80	\$12.75	\$20.41	\$0.62	\$70.58
6	80	\$39.26	\$12.75	\$21.41	\$0.62	\$74.04
7	90	\$44.16	\$12.75	\$22.41	\$0.62	\$79.94

Notes:
Steps 3,4 are 500 hrs. All other steps are 1,000 hrs.

Apprentice to Journeyworker Ratio:1:3

CHAIN SAW OPERATOR LABORERS - ZONE 1	06/01/2019	\$39.40	\$7.85	\$15.85	\$0.00	\$63.10
	12/01/2019	\$40.40	\$7.85	\$15.85	\$0.00	\$64.10
	06/01/2020	\$41.39	\$7.85	\$15.85	\$0.00	\$65.09
	12/01/2020	\$42.37	\$7.85	\$15.85	\$0.00	\$66.07
	06/01/2021	\$43.39	\$7.85	\$15.85	\$0.00	\$67.09
	12/01/2021	\$44.40	\$7.85	\$15.85	\$0.00	\$68.10

For apprentice rates see "Apprentice- LABORER"

CLAM SHELLS/SLURRY BUCKETS/HEADING MACHINES OPERATING ENGINEERS LOCAL 4	06/01/2019	\$49.18	\$12.00	\$15.60	\$0.00	\$76.78
	12/01/2019	\$50.33	\$12.00	\$15.60	\$0.00	\$77.93
	06/01/2020	\$51.43	\$12.00	\$15.60	\$0.00	\$79.03
	12/01/2020	\$52.58	\$12.00	\$15.60	\$0.00	\$80.18
	06/01/2021	\$53.68	\$12.00	\$15.60	\$0.00	\$81.28
	12/01/2021	\$54.83	\$12.00	\$15.60	\$0.00	\$82.43

For apprentice rates see "Apprentice- OPERATING ENGINEERS"

COMPRESSOR OPERATOR OPERATING ENGINEERS LOCAL 4	06/01/2019	\$32.28	\$12.00	\$15.60	\$0.00	\$59.88
	12/01/2019	\$33.07	\$12.00	\$15.60	\$0.00	\$60.67
	06/01/2020	\$33.82	\$12.00	\$15.60	\$0.00	\$61.42
	12/01/2020	\$34.60	\$12.00	\$15.60	\$0.00	\$62.20
	06/01/2021	\$35.35	\$12.00	\$15.60	\$0.00	\$62.95
	12/01/2021	\$36.14	\$12.00	\$15.60	\$0.00	\$63.74

Classification	Effective Date	Base Wage	Health	Pension	Supplemental Unemployment	Total Rate
For apprentice rates see "Apprentice- OPERATING ENGINEERS"						
DELEADER (BRIDGE) PAINTERS LOCAL 35 - ZONE 2	07/01/2019	\$50.66	\$8.20	\$21.45	\$0.00	\$80.31
	01/01/2020	\$50.96	\$8.20	\$22.10	\$0.00	\$81.26
	07/01/2020	\$52.06	\$8.20	\$22.10	\$0.00	\$82.36
	01/01/2021	\$53.16	\$8.20	\$22.10	\$0.00	\$83.46

Apprentice - PAINTER Local 35 - BRIDGES/TANKS

Effective Date - 07/01/2019

Step	percent	Apprentice Base Wage	Health	Pension	Supplemental Unemployment	Total Rate
1	50	\$25.33	\$8.20	\$0.00	\$0.00	\$33.53
2	55	\$27.86	\$8.20	\$5.78	\$0.00	\$41.84
3	60	\$30.40	\$8.20	\$6.30	\$0.00	\$44.90
4	65	\$32.93	\$8.20	\$6.83	\$0.00	\$47.96
5	70	\$35.46	\$8.20	\$18.30	\$0.00	\$61.96
6	75	\$38.00	\$8.20	\$18.83	\$0.00	\$65.03
7	80	\$40.53	\$8.20	\$19.35	\$0.00	\$68.08
8	90	\$45.59	\$8.20	\$20.40	\$0.00	\$74.19

Effective Date - 01/01/2020

Step	percent	Apprentice Base Wage	Health	Pension	Supplemental Unemployment	Total Rate
1	50	\$25.48	\$8.20	\$0.00	\$0.00	\$33.68
2	55	\$28.03	\$8.20	\$5.94	\$0.00	\$42.17
3	60	\$30.58	\$8.20	\$6.48	\$0.00	\$45.26
4	65	\$33.12	\$8.20	\$7.02	\$0.00	\$48.34
5	70	\$35.67	\$8.20	\$18.51	\$0.00	\$62.38
6	75	\$38.22	\$8.20	\$19.05	\$0.00	\$65.47
7	80	\$40.77	\$8.20	\$19.59	\$0.00	\$68.56
8	90	\$45.86	\$8.20	\$20.67	\$0.00	\$74.73

Notes:

Steps are 750 hrs.

Apprentice to Journeyworker Ratio:1:1

DEMO: ADZEMAN LABORERS - ZONE 1	06/01/2019	\$39.30	\$7.85	\$15.85	\$0.00	\$63.00
	12/01/2019	\$40.30	\$7.85	\$15.85	\$0.00	\$64.00
For apprentice rates see "Apprentice- LABORER"						
DEMO: BACKHOE/LOADER/HAMMER OPERATOR LABORERS - ZONE 1	06/01/2019	\$40.30	\$7.85	\$15.85	\$0.00	\$64.00
	12/01/2019	\$41.30	\$7.85	\$15.85	\$0.00	\$65.00
For apprentice rates see "Apprentice- LABORER"						
DEMO: BURNERS LABORERS - ZONE 1	06/01/2019	\$40.05	\$7.85	\$15.85	\$0.00	\$63.75
	12/01/2019	\$41.05	\$7.85	\$15.85	\$0.00	\$64.75
For apprentice rates see "Apprentice- LABORER"						
DEMO: CONCRETE CUTTER/SAWYER LABORERS - ZONE 1	06/01/2019	\$40.30	\$7.85	\$15.85	\$0.00	\$64.00
	12/01/2019	\$41.30	\$7.85	\$15.85	\$0.00	\$65.00
For apprentice rates see "Apprentice- LABORER"						

Classification	Effective Date	Base Wage	Health	Pension	Supplemental Unemployment	Total Rate
DEMO: JACKHAMMER OPERATOR <i>LABORERS - ZONE 1</i>	06/01/2019	\$40.05	\$7.85	\$15.85	\$0.00	\$63.75
	12/01/2019	\$41.05	\$7.85	\$15.85	\$0.00	\$64.75
For apprentice rates see "Apprentice- LABORER"						
DEMO: WRECKING LABORER <i>LABORERS - ZONE 1</i>	06/01/2019	\$39.30	\$7.85	\$15.85	\$0.00	\$63.00
	12/01/2019	\$40.30	\$7.85	\$15.85	\$0.00	\$64.00
For apprentice rates see "Apprentice- LABORER"						
DIRECTIONAL DRILL MACHINE OPERATOR <i>OPERATING ENGINEERS LOCAL 4</i>	06/01/2019	\$47.69	\$12.00	\$15.60	\$0.00	\$75.29
	12/01/2019	\$48.83	\$12.00	\$15.60	\$0.00	\$76.43
	06/01/2020	\$49.91	\$12.00	\$15.60	\$0.00	\$77.51
	12/01/2020	\$51.05	\$12.00	\$15.60	\$0.00	\$78.65
	06/01/2021	\$52.14	\$12.00	\$15.60	\$0.00	\$79.74
	12/01/2021	\$53.28	\$12.00	\$15.60	\$0.00	\$80.88
For apprentice rates see "Apprentice- OPERATING ENGINEERS"						
DIVER <i>PILE DRIVER LOCAL 56 (ZONE 1)</i>	08/01/2018	\$65.20	\$9.90	\$21.15	\$0.00	\$96.25
	08/01/2019	\$68.52	\$9.90	\$21.15	\$0.00	\$99.57
For apprentice rates see "Apprentice- PILE DRIVER"						
DIVER TENDER <i>PILE DRIVER LOCAL 56 (ZONE 1)</i>	08/01/2018	\$46.57	\$9.90	\$21.15	\$0.00	\$77.62
	08/01/2019	\$48.94	\$9.90	\$21.15	\$0.00	\$79.99
For apprentice rates see "Apprentice- PILE DRIVER"						
DIVER TENDER (EFFLUENT) <i>PILE DRIVER LOCAL 56 (ZONE 1)</i>	08/01/2018	\$69.86	\$9.90	\$21.15	\$0.00	\$100.91
	08/01/2019	\$73.41	\$9.90	\$21.15	\$0.00	\$104.46
For apprentice rates see "Apprentice- PILE DRIVER"						
DIVER/SLURRY (EFFLUENT) <i>PILE DRIVER LOCAL 56 (ZONE 1)</i>	08/01/2018	\$97.80	\$9.90	\$21.15	\$0.00	\$128.85
	08/01/2019	\$102.78	\$9.90	\$21.15	\$0.00	\$133.83
For apprentice rates see "Apprentice- PILE DRIVER"						
DRAWBRIDGE OPERATOR (Construction) <i>ELECTRICIANS LOCAL 103</i>	03/01/2019	\$51.10	\$13.00	\$18.88	\$0.00	\$82.98
For apprentice rates see "Apprentice- ELECTRICIAN"						
ELECTRICIAN <i>ELECTRICIANS LOCAL 103</i>	03/01/2019	\$51.10	\$13.00	\$18.88	\$0.00	\$82.98

Apprentice - ELECTRICIAN - Local 103

Effective Date - 03/01/2019

Step	percent	Apprentice Base Wage	Health	Pension	Supplemental Unemployment	Total Rate
1	40	\$20.44	\$13.00	\$0.61	\$0.00	\$34.05
2	40	\$20.44	\$13.00	\$0.61	\$0.00	\$34.05
3	45	\$23.00	\$13.00	\$14.34	\$0.00	\$50.34
4	45	\$23.00	\$13.00	\$14.34	\$0.00	\$50.34
5	50	\$25.55	\$13.00	\$14.76	\$0.00	\$53.31
6	55	\$28.11	\$13.00	\$15.17	\$0.00	\$56.28
7	60	\$30.66	\$13.00	\$15.58	\$0.00	\$59.24
8	65	\$33.22	\$13.00	\$16.00	\$0.00	\$62.22
9	70	\$35.77	\$13.00	\$16.40	\$0.00	\$65.17
10	75	\$38.33	\$13.00	\$16.82	\$0.00	\$68.15

Notes:
App Prior 1/1/03; 30/35/40/45/50/55/65/70/75/80

Apprentice to Journeyworker Ratio:2:3***

ELEVATOR CONSTRUCTOR	01/01/2019	\$59.47	\$15.58	\$17.51	\$0.00	\$92.56
ELEVATOR CONSTRUCTORS LOCAL 4	01/01/2020	\$61.42	\$15.73	\$18.41	\$0.00	\$95.56
	01/01/2021	\$63.47	\$15.88	\$19.31	\$0.00	\$98.66
	01/01/2022	\$65.62	\$16.03	\$20.21	\$0.00	\$101.86

Apprentice - ELEVATOR CONSTRUCTOR - Local 4

Effective Date - 01/01/2019

Step	percent	Apprentice Base Wage	Health	Pension	Supplemental Unemployment	Total Rate
1	50	\$29.74	\$15.58	\$0.00	\$0.00	\$45.32
2	55	\$32.71	\$15.58	\$17.51	\$0.00	\$65.80
3	65	\$38.66	\$15.58	\$17.51	\$0.00	\$71.75
4	70	\$41.63	\$15.58	\$17.51	\$0.00	\$74.72
5	80	\$47.58	\$15.58	\$17.51	\$0.00	\$80.67

Effective Date - 01/01/2020

Step	percent	Apprentice Base Wage	Health	Pension	Supplemental Unemployment	Total Rate
1	50	\$30.71	\$15.73	\$0.00	\$0.00	\$46.44
2	55	\$33.78	\$15.73	\$18.41	\$0.00	\$67.92
3	65	\$39.92	\$15.73	\$18.41	\$0.00	\$74.06
4	70	\$42.99	\$15.73	\$18.41	\$0.00	\$77.13
5	80	\$49.14	\$15.73	\$18.41	\$0.00	\$83.28

Notes:
Steps 1-2 are 6 mos.; Steps 3-5 are 1 year

Apprentice to Journeyworker Ratio:1:1

Classification	Effective Date	Base Wage	Health	Pension	Supplemental Unemployment	Total Rate
ELEVATOR CONSTRUCTOR HELPER <i>ELEVATOR CONSTRUCTORS LOCAL 4</i>	01/01/2019	\$41.63	\$15.58	\$17.51	\$0.00	\$74.72
	01/01/2020	\$42.99	\$15.73	\$18.41	\$0.00	\$77.13
	01/01/2021	\$44.43	\$15.88	\$19.31	\$0.00	\$79.62
	01/01/2022	\$45.93	\$16.03	\$20.21	\$0.00	\$82.17
For apprentice rates see "Apprentice - ELEVATOR CONSTRUCTOR"						
FENCE & GUARD RAIL ERECTOR <i>LABORERS - ZONE 1</i>	06/01/2019	\$39.40	\$7.85	\$15.85	\$0.00	\$63.10
	12/01/2019	\$40.40	\$7.85	\$15.85	\$0.00	\$64.10
	06/01/2020	\$41.39	\$7.85	\$15.85	\$0.00	\$65.09
	12/01/2020	\$42.37	\$7.85	\$15.85	\$0.00	\$66.07
	06/01/2021	\$43.39	\$7.85	\$15.85	\$0.00	\$67.09
	12/01/2021	\$44.40	\$7.85	\$15.85	\$0.00	\$68.10
For apprentice rates see "Apprentice- LABORER"						
FIELD ENG.INST.PERSON-BLDG,SITE,HVY/HWY <i>OPERATING ENGINEERS LOCAL 4</i>	05/01/2019	\$43.68	\$11.50	\$15.60	\$0.00	\$70.78
	11/01/2019	\$44.68	\$11.50	\$15.60	\$0.00	\$71.78
	05/01/2020	\$45.83	\$11.50	\$15.60	\$0.00	\$72.93
	11/01/2020	\$46.83	\$11.50	\$15.60	\$0.00	\$73.93
	05/01/2021	\$47.98	\$11.50	\$15.60	\$0.00	\$75.08
	11/01/2021	\$48.98	\$11.50	\$15.60	\$0.00	\$76.08
	05/01/2022	\$50.13	\$11.50	\$15.60	\$0.00	\$77.23
For apprentice rates see "Apprentice- OPERATING ENGINEERS"						
FIELD ENG.PARTY CHIEF-BLDG,SITE,HVY/HWY <i>OPERATING ENGINEERS LOCAL 4</i>	05/01/2019	\$45.17	\$11.50	\$15.60	\$0.00	\$72.27
	11/01/2019	\$46.18	\$11.50	\$15.60	\$0.00	\$73.28
	05/01/2020	\$47.33	\$11.50	\$15.60	\$0.00	\$74.43
	11/01/2020	\$48.34	\$11.50	\$15.60	\$0.00	\$75.44
	05/01/2021	\$49.50	\$11.50	\$15.60	\$0.00	\$76.60
	11/01/2021	\$50.51	\$11.50	\$15.60	\$0.00	\$77.61
	05/01/2022	\$51.67	\$11.50	\$15.60	\$0.00	\$78.77
For apprentice rates see "Apprentice- OPERATING ENGINEERS"						
FIELD ENG.ROD PERSON-BLDG,SITE,HVY/HWY <i>OPERATING ENGINEERS LOCAL 4</i>	05/01/2019	\$22.48	\$11.50	\$15.60	\$0.00	\$49.58
	11/01/2019	\$23.07	\$11.50	\$15.60	\$0.00	\$50.17
	05/01/2020	\$23.74	\$11.50	\$15.60	\$0.00	\$50.84
	11/01/2020	\$24.33	\$11.50	\$15.60	\$0.00	\$51.43
	05/01/2021	\$25.01	\$11.50	\$15.60	\$0.00	\$52.11
	11/01/2021	\$25.61	\$11.50	\$15.60	\$0.00	\$52.71
	05/01/2022	\$26.28	\$11.50	\$15.60	\$0.00	\$53.38
For apprentice rates see "Apprentice- OPERATING ENGINEERS"						
FIRE ALARM INSTALLER <i>ELECTRICIANS LOCAL 103</i>	03/01/2019	\$51.10	\$13.00	\$18.88	\$0.00	\$82.98
For apprentice rates see "Apprentice- ELECTRICIAN"						
FIRE ALARM REPAIR / MAINTENANCE / COMMISSIONING <i>ELECTRICIANS LOCAL 103</i>	03/01/2019	\$38.33	\$13.00	\$16.82	\$0.00	\$68.15
For apprentice rates see "Apprentice- TELECOMMUNICATIONS TECHNICIAN"						

Classification	Effective Date	Base Wage	Health	Pension	Supplemental Unemployment	Total Rate
FIREMAN (ASST. ENGINEER) <i>OPERATING ENGINEERS LOCAL 4</i>	06/01/2019	\$39.54	\$12.00	\$15.60	\$0.00	\$67.14
	12/01/2019	\$40.49	\$12.00	\$15.60	\$0.00	\$68.09
	06/01/2020	\$41.40	\$12.00	\$15.60	\$0.00	\$69.00
	12/01/2020	\$42.35	\$12.00	\$15.60	\$0.00	\$69.95
	06/01/2021	\$43.26	\$12.00	\$15.60	\$0.00	\$70.86
	12/01/2021	\$44.21	\$12.00	\$15.60	\$0.00	\$71.81
For apprentice rates see "Apprentice- OPERATING ENGINEERS"						
FLAGGER & SIGNALER <i>LABORERS - ZONE 1</i>	06/01/2019	\$22.50	\$7.85	\$15.85	\$0.00	\$46.20
	12/01/2019	\$23.50	\$7.85	\$15.85	\$0.00	\$47.20
	06/01/2020	\$23.50	\$7.85	\$15.85	\$0.00	\$47.20
	12/01/2020	\$24.50	\$7.85	\$15.85	\$0.00	\$48.20
	06/01/2021	\$24.50	\$7.85	\$15.85	\$0.00	\$48.20
	12/01/2021	\$24.50	\$7.85	\$15.85	\$0.00	\$48.20
For apprentice rates see "Apprentice- LABORER"						
FLOORCOVERER <i>FLOORCOVERERS LOCAL 2168 ZONE 1</i>	03/01/2016	\$42.13	\$9.80	\$17.62	\$0.00	\$69.55

Apprentice - FLOORCOVERER - Local 2168 Zone 1

Effective Date - 03/01/2016

Step	percent	Apprentice Base Wage	Health	Pension	Supplemental Unemployment	Total Rate
1	50	\$21.07	\$9.80	\$1.79	\$0.00	\$32.66
2	55	\$23.17	\$9.80	\$1.79	\$0.00	\$34.76
3	60	\$25.28	\$9.80	\$12.25	\$0.00	\$47.33
4	65	\$27.38	\$9.80	\$12.25	\$0.00	\$49.43
5	70	\$29.49	\$9.80	\$14.04	\$0.00	\$53.33
6	75	\$31.60	\$9.80	\$14.04	\$0.00	\$55.44
7	80	\$33.70	\$9.80	\$15.83	\$0.00	\$59.33
8	85	\$35.81	\$9.80	\$15.83	\$0.00	\$61.44

Notes: Steps are 750 hrs.

% After 09/1/17; 45/45/55/55/70/70/80/80 (1500hr Steps)

Step 1&2 \$30.55/ 3&4 \$36.49/ 5&6 \$53.33/ 7&8 \$59.33

Apprentice to Journeyworker Ratio:1:1

FORK LIFT/CHERRY PICKER <i>OPERATING ENGINEERS LOCAL 4</i>	06/01/2019	\$48.18	\$12.00	\$15.60	\$0.00	\$75.78
	12/01/2019	\$49.33	\$12.00	\$15.60	\$0.00	\$76.93
	06/01/2020	\$50.43	\$12.00	\$15.60	\$0.00	\$78.03
	12/01/2020	\$51.58	\$12.00	\$15.60	\$0.00	\$79.18
	06/01/2021	\$52.68	\$12.00	\$15.60	\$0.00	\$80.28
	12/01/2021	\$53.83	\$12.00	\$15.60	\$0.00	\$81.43
For apprentice rates see "Apprentice- OPERATING ENGINEERS"						
GENERATOR/LIGHTING PLANT/HEATERS <i>OPERATING ENGINEERS LOCAL 4</i>	06/01/2019	\$32.28	\$12.00	\$15.60	\$0.00	\$59.88
	12/01/2019	\$33.07	\$12.00	\$15.60	\$0.00	\$60.67
	06/01/2020	\$33.82	\$12.00	\$15.60	\$0.00	\$61.42
	12/01/2020	\$34.60	\$12.00	\$15.60	\$0.00	\$62.20
	06/01/2021	\$35.35	\$12.00	\$15.60	\$0.00	\$62.95
	12/01/2021	\$36.14	\$12.00	\$15.60	\$0.00	\$63.74

Classification	Effective Date	Base Wage	Health	Pension	Supplemental Unemployment	Total Rate
For apprentice rates see "Apprentice- OPERATING ENGINEERS"						
GLAZIER (GLASS PLANK/AIR BARRIER/INTERIOR SYSTEMS) <i>GLAZIERS LOCAL 35 (ZONE 2)</i>	07/01/2019	\$40.16	\$8.20	\$21.45	\$0.00	\$69.81
	01/01/2020	\$40.46	\$8.20	\$22.10	\$0.00	\$70.76
	07/01/2020	\$41.56	\$8.20	\$22.10	\$0.00	\$71.86
	01/01/2021	\$42.66	\$8.20	\$22.10	\$0.00	\$72.96

Apprentice - GLAZIER - Local 35 Zone 2

Effective Date - 07/01/2019

Step	percent	Apprentice Base Wage	Health	Pension	Supplemental Unemployment	Total Rate
1	50	\$20.08	\$8.20	\$0.00	\$0.00	\$28.28
2	55	\$22.09	\$8.20	\$5.78	\$0.00	\$36.07
3	60	\$24.10	\$8.20	\$6.30	\$0.00	\$38.60
4	65	\$26.10	\$8.20	\$6.83	\$0.00	\$41.13
5	70	\$28.11	\$8.20	\$18.30	\$0.00	\$54.61
6	75	\$30.12	\$8.20	\$18.83	\$0.00	\$57.15
7	80	\$32.13	\$8.20	\$19.35	\$0.00	\$59.68
8	90	\$36.14	\$8.20	\$20.40	\$0.00	\$64.74

Effective Date - 01/01/2020

Step	percent	Apprentice Base Wage	Health	Pension	Supplemental Unemployment	Total Rate
1	50	\$20.23	\$8.20	\$0.00	\$0.00	\$28.43
2	55	\$22.25	\$8.20	\$5.94	\$0.00	\$36.39
3	60	\$24.28	\$8.20	\$6.48	\$0.00	\$38.96
4	65	\$26.30	\$8.20	\$7.02	\$0.00	\$41.52
5	70	\$28.32	\$8.20	\$18.51	\$0.00	\$55.03
6	75	\$30.35	\$8.20	\$19.05	\$0.00	\$57.60
7	80	\$32.37	\$8.20	\$19.59	\$0.00	\$60.16
8	90	\$36.41	\$8.20	\$20.67	\$0.00	\$65.28

Notes:

Steps are 750 hrs.

Apprentice to Journeyworker Ratio:1:1

HOISTING ENGINEER/CRANES/GRADALLS <i>OPERATING ENGINEERS LOCAL 4</i>	06/01/2019	\$48.18	\$12.00	\$15.60	\$0.00	\$75.78
	12/01/2019	\$49.33	\$12.00	\$15.60	\$0.00	\$76.93
	06/01/2020	\$50.43	\$12.00	\$15.60	\$0.00	\$78.03
	12/01/2020	\$51.58	\$12.00	\$15.60	\$0.00	\$79.18
	06/01/2021	\$52.68	\$12.00	\$15.60	\$0.00	\$80.28
	12/01/2021	\$53.83	\$12.00	\$15.60	\$0.00	\$81.43

Classification

Effective Date Base Wage Health Pension Supplemental Unemployment Total Rate

Apprentice - OPERATING ENGINEERS - Local 4

Effective Date - 06/01/2019

Step	percent	Apprentice Base Wage	Health	Pension	Supplemental Unemployment	Total Rate
1	55	\$26.50	\$12.00	\$0.00	\$0.00	\$38.50
2	60	\$28.91	\$12.00	\$15.60	\$0.00	\$56.51
3	65	\$31.32	\$12.00	\$15.60	\$0.00	\$58.92
4	70	\$33.73	\$12.00	\$15.60	\$0.00	\$61.33
5	75	\$36.14	\$12.00	\$15.60	\$0.00	\$63.74
6	80	\$38.54	\$12.00	\$15.60	\$0.00	\$66.14
7	85	\$40.95	\$12.00	\$15.60	\$0.00	\$68.55
8	90	\$43.36	\$12.00	\$15.60	\$0.00	\$70.96

Effective Date - 12/01/2019

Step	percent	Apprentice Base Wage	Health	Pension	Supplemental Unemployment	Total Rate
1	55	\$27.13	\$12.00	\$0.00	\$0.00	\$39.13
2	60	\$29.60	\$12.00	\$15.60	\$0.00	\$57.20
3	65	\$32.06	\$12.00	\$15.60	\$0.00	\$59.66
4	70	\$34.53	\$12.00	\$15.60	\$0.00	\$62.13
5	75	\$37.00	\$12.00	\$15.60	\$0.00	\$64.60
6	80	\$39.46	\$12.00	\$15.60	\$0.00	\$67.06
7	85	\$41.93	\$12.00	\$15.60	\$0.00	\$69.53
8	90	\$44.40	\$12.00	\$15.60	\$0.00	\$72.00

Notes:

Apprentice to Journeyworker Ratio:1:6

HVAC (DUCTWORK) SHEETMETAL WORKERS LOCAL 17 - A	02/01/2019	\$46.50	\$13.20	\$24.12	\$2.52	\$86.34
	08/01/2019	\$48.10	\$13.20	\$24.12	\$2.56	\$87.98
	02/01/2020	\$49.75	\$13.20	\$24.12	\$2.61	\$89.68
	08/01/2020	\$51.35	\$13.20	\$24.12	\$2.66	\$91.33
	02/01/2021	\$53.00	\$13.20	\$24.12	\$2.71	\$93.03
	08/01/2021	\$54.75	\$13.20	\$24.12	\$2.76	\$94.83
	02/01/2022	\$56.50	\$13.20	\$24.12	\$2.81	\$96.63

For apprentice rates see "Apprentice- SHEET METAL WORKER"

HVAC (ELECTRICAL CONTROLS) ELECTRICIANS LOCAL 103	03/01/2019	\$51.10	\$13.00	\$18.88	\$0.00	\$82.98
--	------------	---------	---------	---------	--------	---------

For apprentice rates see "Apprentice- ELECTRICIAN"

HVAC (TESTING AND BALANCING - AIR) SHEETMETAL WORKERS LOCAL 17 - A	02/01/2019	\$46.50	\$13.20	\$24.12	\$2.52	\$86.34
	08/01/2019	\$48.10	\$13.20	\$24.12	\$2.56	\$87.98
	02/01/2020	\$49.75	\$13.20	\$24.12	\$2.61	\$89.68
	08/01/2020	\$51.35	\$13.20	\$24.12	\$2.66	\$91.33
	02/01/2021	\$53.00	\$13.20	\$24.12	\$2.71	\$93.03
	08/01/2021	\$54.75	\$13.20	\$24.12	\$2.76	\$94.83
	02/01/2022	\$56.50	\$13.20	\$24.12	\$2.81	\$96.63

Classification	Effective Date	Base Wage	Health	Pension	Supplemental Unemployment	Total Rate
For apprentice rates see "Apprentice- SHEET METAL WORKER"						
HVAC (TESTING AND BALANCING -WATER) <i>PIPEFITTERS LOCAL 537</i>	03/01/2019	\$53.19	\$10.95	\$19.74	\$0.00	\$83.88
	09/01/2019	\$54.69	\$10.95	\$19.74	\$0.00	\$85.38
	03/01/2020	\$56.19	\$10.95	\$19.74	\$0.00	\$86.88
	09/01/2020	\$57.69	\$10.95	\$19.74	\$0.00	\$88.38
	03/01/2021	\$59.19	\$10.95	\$19.74	\$0.00	\$89.88
For apprentice rates see "Apprentice- PIPEFITTER" or "PLUMBER/PIPEFITTER"						
HVAC MECHANIC <i>PIPEFITTERS LOCAL 537</i>	03/01/2019	\$53.19	\$10.95	\$19.74	\$0.00	\$83.88
	09/01/2019	\$54.69	\$10.95	\$19.74	\$0.00	\$85.38
	03/01/2020	\$56.19	\$10.95	\$19.74	\$0.00	\$86.88
	09/01/2020	\$57.69	\$10.95	\$19.74	\$0.00	\$88.38
	03/01/2021	\$59.19	\$10.95	\$19.74	\$0.00	\$89.88
For apprentice rates see "Apprentice- PIPEFITTER" or "PLUMBER/PIPEFITTER"						
HYDRAULIC DRILLS <i>LABORERS - ZONE 1</i>	06/01/2019	\$39.90	\$7.85	\$15.85	\$0.00	\$63.60
	12/01/2019	\$40.90	\$7.85	\$15.85	\$0.00	\$64.60
	06/01/2020	\$41.89	\$7.85	\$15.85	\$0.00	\$65.59
	12/01/2020	\$42.87	\$7.85	\$15.85	\$0.00	\$66.57
	06/01/2021	\$43.89	\$7.85	\$15.85	\$0.00	\$67.59
	12/01/2021	\$44.90	\$7.85	\$15.85	\$0.00	\$68.60
For apprentice rates see "Apprentice- LABORER"						
INSULATOR (PIPES & TANKS) <i>HEAT & FROST INSULATORS LOCAL 6 (BOSTON)</i>	09/01/2018	\$47.09	\$12.50	\$15.60	\$0.00	\$75.19
	09/01/2019	\$49.59	\$12.50	\$15.60	\$0.00	\$77.69

Apprentice - ASBESTOS INSULATOR (Pipes & Tanks) - Local 6 Boston

Effective Date - 09/01/2018

Step	percent	Apprentice Base Wage	Health	Pension	Supplemental Unemployment	Total Rate
1	50	\$23.55	\$12.50	\$11.40	\$0.00	\$47.45
2	60	\$28.25	\$12.50	\$12.24	\$0.00	\$52.99
3	70	\$32.96	\$12.50	\$13.08	\$0.00	\$58.54
4	80	\$37.67	\$12.50	\$13.92	\$0.00	\$64.09

Effective Date - 09/01/2019

Step	percent	Apprentice Base Wage	Health	Pension	Supplemental Unemployment	Total Rate
1	50	\$24.80	\$12.50	\$11.40	\$0.00	\$48.70
2	60	\$29.75	\$12.50	\$12.24	\$0.00	\$54.49
3	70	\$34.71	\$12.50	\$13.08	\$0.00	\$60.29
4	80	\$39.67	\$12.50	\$13.92	\$0.00	\$66.09

Notes:

Steps are 1 year

Apprentice to Journeyworker Ratio:1:4

IRONWORKER/WELDER <i>IRONWORKERS LOCAL 7 (BOSTON AREA)</i>	03/16/2019	\$46.66	\$8.00	\$23.50	\$0.00	\$78.16
---	------------	---------	--------	---------	--------	---------

Classification

Effective Date Base Wage Health Pension Supplemental Unemployment Total Rate

Apprentice - IRONWORKER - Local 7 Boston

Effective Date - 03/16/2019

Step	percent	Apprentice Base Wage	Health	Pension	Supplemental Unemployment	Total Rate
1	60	\$28.00	\$8.00	\$23.50	\$0.00	\$59.50
2	70	\$32.66	\$8.00	\$23.50	\$0.00	\$64.16
3	75	\$35.00	\$8.00	\$23.50	\$0.00	\$66.50
4	80	\$37.33	\$8.00	\$23.50	\$0.00	\$68.83
5	85	\$39.66	\$8.00	\$23.50	\$0.00	\$71.16
6	90	\$41.99	\$8.00	\$23.50	\$0.00	\$73.49

Notes:

** Structural 1:6; Ornamental 1:4

Apprentice to Journeyworker Ratio:**

JACKHAMMER & PAVING BREAKER OPERATOR LABORERS - ZONE 1	06/01/2019	\$39.40	\$7.85	\$15.85	\$0.00	\$63.10
	12/01/2019	\$40.40	\$7.85	\$15.85	\$0.00	\$64.10
	06/01/2020	\$41.39	\$7.85	\$15.85	\$0.00	\$65.09
	12/01/2020	\$42.37	\$7.85	\$15.85	\$0.00	\$66.07
	06/01/2021	\$43.39	\$7.85	\$15.85	\$0.00	\$67.09
	12/01/2021	\$44.40	\$7.85	\$15.85	\$0.00	\$68.10

For apprentice rates see "Apprentice- LABORER"

LABORER LABORERS - ZONE 1	06/01/2019	\$39.15	\$7.85	\$15.85	\$0.00	\$62.85
	12/01/2019	\$40.15	\$7.85	\$15.85	\$0.00	\$63.85
	06/01/2020	\$41.14	\$7.85	\$15.85	\$0.00	\$64.84
	12/01/2020	\$42.12	\$7.85	\$15.85	\$0.00	\$65.82
	06/01/2021	\$43.14	\$7.85	\$15.85	\$0.00	\$66.84
	12/01/2021	\$44.15	\$7.85	\$15.85	\$0.00	\$67.85

Classification

Effective Date Base Wage Health Pension Supplemental Unemployment Total Rate

Apprentice - LABORER - Zone 1

Effective Date - 06/01/2019

Step	percent	Apprentice Base Wage	Health	Pension	Supplemental Unemployment	Total Rate
1	60	\$23.49	\$7.85	\$15.85	\$0.00	\$47.19
2	70	\$27.41	\$7.85	\$15.85	\$0.00	\$51.11
3	80	\$31.32	\$7.85	\$15.85	\$0.00	\$55.02
4	90	\$35.24	\$7.85	\$15.85	\$0.00	\$58.94

Effective Date - 12/01/2019

Step	percent	Apprentice Base Wage	Health	Pension	Supplemental Unemployment	Total Rate
1	60	\$24.09	\$7.85	\$15.85	\$0.00	\$47.79
2	70	\$28.11	\$7.85	\$15.85	\$0.00	\$51.81
3	80	\$32.12	\$7.85	\$15.85	\$0.00	\$55.82
4	90	\$36.14	\$7.85	\$15.85	\$0.00	\$59.84

Notes:

Apprentice to Journeyworker Ratio:1:5

LABORER: CARPENTER TENDER LABORERS - ZONE 1	06/01/2019	\$39.15	\$7.85	\$15.85	\$0.00	\$62.85
	12/01/2019	\$40.15	\$7.85	\$15.85	\$0.00	\$63.85
	06/01/2020	\$41.14	\$7.85	\$15.85	\$0.00	\$64.84
	12/01/2020	\$42.12	\$7.85	\$15.85	\$0.00	\$65.82
	06/01/2021	\$43.14	\$7.85	\$15.85	\$0.00	\$66.84
	12/01/2021	\$44.15	\$7.85	\$15.85	\$0.00	\$67.85

For apprentice rates see "Apprentice- LABORER"

LABORER: CEMENT FINISHER TENDER LABORERS - ZONE 1	06/01/2019	\$39.15	\$7.85	\$15.85	\$0.00	\$62.85
	12/01/2019	\$40.15	\$7.85	\$15.85	\$0.00	\$63.85
	06/01/2020	\$41.14	\$7.85	\$15.85	\$0.00	\$64.84
	12/01/2020	\$42.12	\$7.85	\$15.85	\$0.00	\$65.82
	06/01/2021	\$43.14	\$7.85	\$15.85	\$0.00	\$66.84
	12/01/2021	\$44.15	\$7.85	\$15.85	\$0.00	\$67.85

For apprentice rates see "Apprentice- LABORER"

LABORER: HAZARDOUS WASTE/ASBESTOS REMOVER LABORERS - ZONE 1	06/01/2019	\$39.30	\$7.85	\$15.85	\$0.00	\$63.00
	12/01/2019	\$40.30	\$7.85	\$15.85	\$0.00	\$64.00

For apprentice rates see "Apprentice- LABORER"

LABORER: MASON TENDER LABORERS - ZONE 1	06/01/2019	\$39.40	\$7.85	\$15.85	\$0.00	\$63.10
	12/01/2019	\$40.40	\$7.85	\$15.85	\$0.00	\$64.10
	06/01/2020	\$41.39	\$7.85	\$15.85	\$0.00	\$65.09
	12/01/2020	\$42.37	\$7.85	\$15.85	\$0.00	\$66.07
	06/01/2021	\$43.39	\$7.85	\$15.85	\$0.00	\$67.09
	12/01/2021	\$44.40	\$7.85	\$15.85	\$0.00	\$68.10

For apprentice rates see "Apprentice- LABORER"

Classification	Effective Date	Base Wage	Health	Pension	Supplemental Unemployment	Total Rate
LABORER: MULTI-TRADE TENDER <i>LABORERS - ZONE 1</i>	06/01/2019	\$39.15	\$7.85	\$15.85	\$0.00	\$62.85
	12/01/2019	\$40.15	\$7.85	\$15.85	\$0.00	\$63.85
	06/01/2020	\$41.14	\$7.85	\$15.85	\$0.00	\$64.84
	12/01/2020	\$42.12	\$7.85	\$15.85	\$0.00	\$65.82
	06/01/2021	\$43.14	\$7.85	\$15.85	\$0.00	\$66.84
	12/01/2021	\$44.15	\$7.85	\$15.85	\$0.00	\$67.85
	For apprentice rates see "Apprentice- LABORER"					
LABORER: TREE REMOVER <i>LABORERS - ZONE 1</i>	06/01/2019	\$39.15	\$7.85	\$15.85	\$0.00	\$62.85
	12/01/2019	\$40.15	\$7.85	\$15.85	\$0.00	\$63.85
	06/01/2020	\$41.14	\$7.85	\$15.85	\$0.00	\$64.84
	12/01/2020	\$42.12	\$7.85	\$15.85	\$0.00	\$65.82
	06/01/2021	\$43.14	\$7.85	\$15.85	\$0.00	\$66.84
	12/01/2021	\$44.15	\$7.85	\$15.85	\$0.00	\$67.85
	This classification applies to all tree work associated with the removal of standing trees, and trimming and removal of branches and limbs when the work is not done for a utility company for the purpose of operation, maintenance or repair of utility company equipment. For apprentice rates see "Apprentice- LABORER"					
LASER BEAM OPERATOR <i>LABORERS - ZONE 1</i>	06/01/2019	\$39.40	\$7.85	\$15.85	\$0.00	\$63.10
	12/01/2019	\$40.40	\$7.85	\$15.85	\$0.00	\$64.10
	06/01/2020	\$41.39	\$7.85	\$15.85	\$0.00	\$65.09
	12/01/2020	\$42.37	\$7.85	\$15.85	\$0.00	\$66.07
	06/01/2021	\$43.39	\$7.85	\$15.85	\$0.00	\$67.09
	12/01/2021	\$44.40	\$7.85	\$15.85	\$0.00	\$68.10
	For apprentice rates see "Apprentice- LABORER"					
MARBLE & TILE FINISHERS <i>BRICKLAYERS LOCAL 3 - MARBLE & TILE</i>	02/01/2019	\$40.91	\$10.75	\$18.97	\$0.00	\$70.63
	08/01/2019	\$41.49	\$10.75	\$19.61	\$0.00	\$71.85
	02/01/2020	\$42.00	\$10.75	\$19.61	\$0.00	\$72.36
	08/01/2020	\$43.08	\$10.75	\$19.76	\$0.00	\$73.59
	02/01/2021	\$43.59	\$10.75	\$19.76	\$0.00	\$74.10
	08/01/2021	\$44.71	\$10.75	\$19.92	\$0.00	\$75.38
	02/01/2022	\$45.18	\$10.75	\$19.92	\$0.00	\$75.85

Classification

Effective Date Base Wage Health Pension Supplemental Unemployment Total Rate

Apprentice - MARBLE & TILE FINISHER - Local 3 Marble & Tile

Effective Date - 02/01/2019

Step	percent	Apprentice Base Wage	Health	Pension	Supplemental Unemployment	Total Rate
1	50	\$20.46	\$10.75	\$18.97	\$0.00	\$50.18
2	60	\$24.55	\$10.75	\$18.97	\$0.00	\$54.27
3	70	\$28.64	\$10.75	\$18.97	\$0.00	\$58.36
4	80	\$32.73	\$10.75	\$18.97	\$0.00	\$62.45
5	90	\$36.82	\$10.75	\$18.97	\$0.00	\$66.54

Effective Date - 08/01/2019

Step	percent	Apprentice Base Wage	Health	Pension	Supplemental Unemployment	Total Rate
1	50	\$20.75	\$10.75	\$19.61	\$0.00	\$51.11
2	60	\$24.89	\$10.75	\$19.61	\$0.00	\$55.25
3	70	\$29.04	\$10.75	\$19.61	\$0.00	\$59.40
4	80	\$33.19	\$10.75	\$19.61	\$0.00	\$63.55
5	90	\$37.34	\$10.75	\$19.61	\$0.00	\$67.70

Notes:

Apprentice to Journeyworker Ratio:1:3

MARBLE MASONS, TILELAYERS & TERRAZZO MECH	02/01/2019	\$53.57	\$10.75	\$20.66	\$0.00	\$84.98
BRICKLAYERS LOCAL 3 - MARBLE & TILE	08/01/2019	\$54.42	\$10.75	\$21.30	\$0.00	\$86.47
	02/01/2020	\$55.05	\$10.75	\$21.30	\$0.00	\$87.10
	08/01/2020	\$56.40	\$10.75	\$21.45	\$0.00	\$88.60
	02/01/2021	\$57.04	\$10.75	\$21.45	\$0.00	\$89.24
	08/01/2021	\$58.44	\$10.75	\$21.61	\$0.00	\$90.80
	02/01/2022	\$59.01	\$10.75	\$21.61	\$0.00	\$91.37

Classification

Effective Date Base Wage Health Pension Supplemental Unemployment Total Rate

Apprentice - MARBLE-TILE-TERRAZZO MECHANIC - Local 3 Marble & Tile

Effective Date - 02/01/2019

Step	percent	Apprentice Base Wage	Health	Pension	Supplemental Unemployment	Total Rate
1	50	\$26.79	\$10.75	\$20.66	\$0.00	\$58.20
2	60	\$32.14	\$10.75	\$20.66	\$0.00	\$63.55
3	70	\$37.50	\$10.75	\$20.66	\$0.00	\$68.91
4	80	\$42.86	\$10.75	\$20.66	\$0.00	\$74.27
5	90	\$48.21	\$10.75	\$20.66	\$0.00	\$79.62

Effective Date - 08/01/2019

Step	percent	Apprentice Base Wage	Health	Pension	Supplemental Unemployment	Total Rate
1	50	\$27.21	\$10.75	\$21.30	\$0.00	\$59.26
2	60	\$32.65	\$10.75	\$21.30	\$0.00	\$64.70
3	70	\$38.09	\$10.75	\$21.30	\$0.00	\$70.14
4	80	\$43.54	\$10.75	\$21.30	\$0.00	\$75.59
5	90	\$48.98	\$10.75	\$21.30	\$0.00	\$81.03

Notes:

Apprentice to Journeyworker Ratio:1:5

MECH. SWEEPER OPERATOR (ON CONST. SITES) <i>OPERATING ENGINEERS LOCAL 4</i>	06/01/2019	\$47.69	\$12.00	\$15.60	\$0.00	\$75.29
	12/01/2019	\$48.83	\$12.00	\$15.60	\$0.00	\$76.43
	06/01/2020	\$49.91	\$12.00	\$15.60	\$0.00	\$77.51
	12/01/2020	\$51.05	\$12.00	\$15.60	\$0.00	\$78.65
	06/01/2021	\$52.14	\$12.00	\$15.60	\$0.00	\$79.74
	12/01/2021	\$53.28	\$12.00	\$15.60	\$0.00	\$80.88

For apprentice rates see "Apprentice- OPERATING ENGINEERS"

MECHANICS MAINTENANCE <i>OPERATING ENGINEERS LOCAL 4</i>	06/01/2019	\$47.69	\$12.00	\$15.60	\$0.00	\$75.29
	12/01/2019	\$48.83	\$12.00	\$15.60	\$0.00	\$76.43
	06/01/2020	\$49.91	\$12.00	\$15.60	\$0.00	\$77.51
	12/01/2020	\$51.05	\$12.00	\$15.60	\$0.00	\$78.65
	06/01/2021	\$52.14	\$12.00	\$15.60	\$0.00	\$79.74
	12/01/2021	\$53.28	\$12.00	\$15.60	\$0.00	\$80.88

For apprentice rates see "Apprentice- OPERATING ENGINEERS"

MILLWRIGHT (Zone 1) <i>MILLWRIGHTS LOCAL 1121 - Zone 1</i>	04/01/2019	\$42.22	\$9.90	\$18.50	\$0.00	\$70.62
---	------------	---------	--------	---------	--------	---------

Apprentice - MILLWRIGHT - Local 1121 Zone 1

Effective Date - 04/01/2019

Step	percent	Apprentice Base Wage	Health	Pension	Supplemental Unemployment	Total Rate
1	55	\$23.22	\$9.90	\$5.31	\$0.00	\$38.43
2	65	\$27.44	\$9.90	\$15.13	\$0.00	\$52.47
3	75	\$31.67	\$9.90	\$16.10	\$0.00	\$57.67
4	85	\$35.89	\$9.90	\$17.06	\$0.00	\$62.85

Notes:

Steps are 2,000 hours

Apprentice to Journeyworker Ratio:1:5

MORTAR MIXER <i>LABORERS - ZONE 1</i>	06/01/2019	\$39.40	\$7.85	\$15.85	\$0.00	\$63.10
	12/01/2019	\$40.40	\$7.85	\$15.85	\$0.00	\$64.10
	06/01/2020	\$41.39	\$7.85	\$15.85	\$0.00	\$65.09
	12/01/2020	\$42.37	\$7.85	\$15.85	\$0.00	\$66.07
	06/01/2021	\$43.39	\$7.85	\$15.85	\$0.00	\$67.09
	12/01/2021	\$44.40	\$7.85	\$15.85	\$0.00	\$68.10

For apprentice rates see "Apprentice- LABORER"

OILER (OTHER THAN TRUCK CRANES, GRADALLS) <i>OPERATING ENGINEERS LOCAL 4</i>	06/01/2019	\$23.11	\$12.00	\$15.60	\$0.00	\$50.71
	12/01/2019	\$23.68	\$12.00	\$15.60	\$0.00	\$51.28
	06/01/2020	\$24.23	\$12.00	\$15.60	\$0.00	\$51.83
	12/01/2020	\$24.80	\$12.00	\$15.60	\$0.00	\$52.40
	06/01/2021	\$25.35	\$12.00	\$15.60	\$0.00	\$52.95
	12/01/2021	\$25.93	\$12.00	\$15.60	\$0.00	\$53.53

For apprentice rates see "Apprentice- OPERATING ENGINEERS"

OILER (TRUCK CRANES, GRADALLS) <i>OPERATING ENGINEERS LOCAL 4</i>	06/01/2019	\$27.57	\$12.00	\$15.60	\$0.00	\$55.17
	12/01/2019	\$28.24	\$12.00	\$15.60	\$0.00	\$55.84
	06/01/2020	\$28.89	\$12.00	\$15.60	\$0.00	\$56.49
	12/01/2020	\$29.57	\$12.00	\$15.60	\$0.00	\$57.17
	06/01/2021	\$30.21	\$12.00	\$15.60	\$0.00	\$57.81
	12/01/2021	\$30.89	\$12.00	\$15.60	\$0.00	\$58.49

For apprentice rates see "Apprentice- OPERATING ENGINEERS"

OTHER POWER DRIVEN EQUIPMENT - CLASS II <i>OPERATING ENGINEERS LOCAL 4</i>	06/01/2019	\$47.69	\$12.00	\$15.60	\$0.00	\$75.29
	12/01/2019	\$48.83	\$12.00	\$15.60	\$0.00	\$76.43
	06/01/2020	\$49.91	\$12.00	\$15.60	\$0.00	\$77.51
	12/01/2020	\$51.05	\$12.00	\$15.60	\$0.00	\$78.65
	06/01/2021	\$52.14	\$12.00	\$15.60	\$0.00	\$79.74
	12/01/2021	\$53.28	\$12.00	\$15.60	\$0.00	\$80.88

For apprentice rates see "Apprentice- OPERATING ENGINEERS"

PAINTER (BRIDGES/TANKS) <i>PAINTERS LOCAL 35 - ZONE 2</i>	07/01/2019	\$50.66	\$8.20	\$21.45	\$0.00	\$80.31
	01/01/2020	\$50.96	\$8.20	\$22.10	\$0.00	\$81.26
	07/01/2020	\$52.06	\$8.20	\$22.10	\$0.00	\$82.36
	01/01/2021	\$53.16	\$8.20	\$22.10	\$0.00	\$83.46

Classification

Effective Date Base Wage Health Pension Supplemental Unemployment Total Rate

Apprentice - PAINTER Local 35 - BRIDGES/TANKS

Effective Date - 07/01/2019

Step	percent	Apprentice Base Wage	Health	Pension	Supplemental Unemployment	Total Rate
1	50	\$25.33	\$8.20	\$0.00	\$0.00	\$33.53
2	55	\$27.86	\$8.20	\$5.78	\$0.00	\$41.84
3	60	\$30.40	\$8.20	\$6.30	\$0.00	\$44.90
4	65	\$32.93	\$8.20	\$6.83	\$0.00	\$47.96
5	70	\$35.46	\$8.20	\$18.30	\$0.00	\$61.96
6	75	\$38.00	\$8.20	\$18.83	\$0.00	\$65.03
7	80	\$40.53	\$8.20	\$19.35	\$0.00	\$68.08
8	90	\$45.59	\$8.20	\$20.40	\$0.00	\$74.19

Effective Date - 01/01/2020

Step	percent	Apprentice Base Wage	Health	Pension	Supplemental Unemployment	Total Rate
1	50	\$25.48	\$8.20	\$0.00	\$0.00	\$33.68
2	55	\$28.03	\$8.20	\$5.94	\$0.00	\$42.17
3	60	\$30.58	\$8.20	\$6.48	\$0.00	\$45.26
4	65	\$33.12	\$8.20	\$7.02	\$0.00	\$48.34
5	70	\$35.67	\$8.20	\$18.51	\$0.00	\$62.38
6	75	\$38.22	\$8.20	\$19.05	\$0.00	\$65.47
7	80	\$40.77	\$8.20	\$19.59	\$0.00	\$68.56
8	90	\$45.86	\$8.20	\$20.67	\$0.00	\$74.73

Notes:

Steps are 750 hrs.

Apprentice to Journeyworker Ratio:1:1

PAINTER (SIGN, PICTORIAL & DISPLAY) PAINTERS LOCAL 35 - ZONE 2	06/01/2013	\$25.81	\$7.07	\$7.05	\$0.00	\$39.93
---	------------	---------	--------	--------	--------	---------

Classification

Effective Date Base Wage Health Pension Supplemental Unemployment Total Rate

Apprentice - PAINTER SIGN - Local 35 Zone 2

Effective Date - 06/01/2013

Step	percent	Apprentice Base Wage	Health	Pension	Supplemental Unemployment	Total Rate
1	50	\$12.91	\$7.07	\$0.00	\$0.00	\$19.98
2	55	\$14.20	\$7.07	\$2.45	\$0.00	\$23.72
3	60	\$15.49	\$7.07	\$2.45	\$0.00	\$25.01
4	65	\$16.78	\$7.07	\$2.45	\$0.00	\$26.30
5	70	\$18.07	\$7.07	\$7.05	\$0.00	\$32.19
6	75	\$19.36	\$7.07	\$7.05	\$0.00	\$33.48
7	80	\$20.65	\$7.07	\$7.05	\$0.00	\$34.77
8	85	\$21.94	\$7.07	\$7.05	\$0.00	\$36.06
9	90	\$23.23	\$7.07	\$7.05	\$0.00	\$37.35

Notes:
Steps are 4 mos.

Apprentice to Journeyworker Ratio:1:1

PAINTER (SPRAY OR SANDBLAST, NEW) *	07/01/2019	\$41.56	\$8.20	\$21.45	\$0.00	\$71.21
* If 30% or more of surfaces to be painted are new construction, NEW paint rate shall be used. PAINTERS LOCAL 35 - ZONE 2	01/01/2020	\$41.86	\$8.20	\$22.10	\$0.00	\$72.16
	07/01/2020	\$42.96	\$8.20	\$22.10	\$0.00	\$73.26
	01/01/2021	\$44.06	\$8.20	\$22.10	\$0.00	\$74.36

Apprentice - PAINTER Local 35 Zone 2 - Spray/Sandblast - New

Effective Date - 07/01/2019

Step	percent	Apprentice Base Wage	Health	Pension	Supplemental Unemployment	Total Rate
1	50	\$20.78	\$8.20	\$0.00	\$0.00	\$28.98
2	55	\$22.86	\$8.20	\$5.78	\$0.00	\$36.84
3	60	\$24.94	\$8.20	\$6.30	\$0.00	\$39.44
4	65	\$27.01	\$8.20	\$6.83	\$0.00	\$42.04
5	70	\$29.09	\$8.20	\$18.30	\$0.00	\$55.59
6	75	\$31.17	\$8.20	\$18.83	\$0.00	\$58.20
7	80	\$33.25	\$8.20	\$19.35	\$0.00	\$60.80
8	90	\$37.40	\$8.20	\$20.40	\$0.00	\$66.00

Effective Date - 01/01/2020

Step	percent	Apprentice Base Wage	Health	Pension	Supplemental Unemployment	Total Rate
1	50	\$20.93	\$8.20	\$0.00	\$0.00	\$29.13
2	55	\$23.02	\$8.20	\$5.94	\$0.00	\$37.16
3	60	\$25.12	\$8.20	\$6.48	\$0.00	\$39.80
4	65	\$27.21	\$8.20	\$7.02	\$0.00	\$42.43
5	70	\$29.30	\$8.20	\$18.51	\$0.00	\$56.01
6	75	\$31.40	\$8.20	\$19.05	\$0.00	\$58.65
7	80	\$33.49	\$8.20	\$19.59	\$0.00	\$61.28
8	90	\$37.67	\$8.20	\$20.67	\$0.00	\$66.54

Notes:
Steps are 750 hrs.

Apprentice to Journeyworker Ratio:1:1

PAINTER (SPRAY OR SANDBLAST, REPAINT)	07/01/2019	\$39.62	\$8.20	\$21.45	\$0.00	\$69.27
PAINTERS LOCAL 35 - ZONE 2	01/01/2020	\$39.92	\$8.20	\$22.10	\$0.00	\$70.22
	07/01/2020	\$41.02	\$8.20	\$22.10	\$0.00	\$71.32
	01/01/2021	\$42.12	\$8.20	\$22.10	\$0.00	\$72.42

Classification

Effective Date Base Wage Health Pension Supplemental Unemployment Total Rate

Apprentice - PAINTER Local 35 Zone 2 - Spray/Sandblast - Repaint

Effective Date - 07/01/2019

Step	percent	Apprentice Base Wage	Health	Pension	Supplemental Unemployment	Total Rate
1	50	\$19.81	\$8.20	\$0.00	\$0.00	\$28.01
2	55	\$21.79	\$8.20	\$5.78	\$0.00	\$35.77
3	60	\$23.77	\$8.20	\$6.30	\$0.00	\$38.27
4	65	\$25.75	\$8.20	\$6.83	\$0.00	\$40.78
5	70	\$27.73	\$8.20	\$18.30	\$0.00	\$54.23
6	75	\$29.72	\$8.20	\$18.83	\$0.00	\$56.75
7	80	\$31.70	\$8.20	\$19.35	\$0.00	\$59.25
8	90	\$35.66	\$8.20	\$20.40	\$0.00	\$64.26

Effective Date - 01/01/2020

Step	percent	Apprentice Base Wage	Health	Pension	Supplemental Unemployment	Total Rate
1	50	\$19.96	\$8.20	\$0.00	\$0.00	\$28.16
2	55	\$21.96	\$8.20	\$5.94	\$0.00	\$36.10
3	60	\$23.95	\$8.20	\$6.48	\$0.00	\$38.63
4	65	\$25.95	\$8.20	\$7.02	\$0.00	\$41.17
5	70	\$27.94	\$8.20	\$18.51	\$0.00	\$54.65
6	75	\$29.94	\$8.20	\$19.05	\$0.00	\$57.19
7	80	\$31.94	\$8.20	\$19.59	\$0.00	\$59.73
8	90	\$35.93	\$8.20	\$20.67	\$0.00	\$64.80

Notes:

Steps are 750 hrs.

Apprentice to Journeyworker Ratio:1:1

PAINTER (TRAFFIC MARKINGS) LABORERS - ZONE 1	06/01/2019	\$39.15	\$7.85	\$15.85	\$0.00	\$62.85
	12/01/2019	\$40.15	\$7.85	\$15.85	\$0.00	\$63.85
	06/01/2020	\$41.14	\$7.85	\$15.85	\$0.00	\$64.84
	12/01/2020	\$42.12	\$7.85	\$15.85	\$0.00	\$65.82
	06/01/2021	\$43.14	\$7.85	\$15.85	\$0.00	\$66.84
	12/01/2021	\$44.15	\$7.85	\$15.85	\$0.00	\$67.85

For Apprentices rates see "Apprentice- LABORER"

PAINTER / TAPER (BRUSH, NEW) * * If 30% or more of surfaces to be painted are new construction, NEW paint rate shall be used. PAINTERS LOCAL 35 - ZONE 2	07/01/2019	\$40.16	\$8.20	\$21.45	\$0.00	\$69.81
	01/01/2020	\$40.46	\$8.20	\$22.10	\$0.00	\$70.76
	07/01/2020	\$41.56	\$8.20	\$22.10	\$0.00	\$71.86
	01/01/2021	\$42.66	\$8.20	\$22.10	\$0.00	\$72.96

Classification

Effective Date Base Wage Health Pension Supplemental Unemployment Total Rate

Apprentice - PAINTER - Local 35 Zone 2 - BRUSH NEW

Effective Date - 07/01/2019

Step	percent	Apprentice Base Wage	Health	Pension	Supplemental Unemployment	Total Rate
1	50	\$20.08	\$8.20	\$0.00	\$0.00	\$28.28
2	55	\$22.09	\$8.20	\$5.78	\$0.00	\$36.07
3	60	\$24.10	\$8.20	\$6.30	\$0.00	\$38.60
4	65	\$26.10	\$8.20	\$6.83	\$0.00	\$41.13
5	70	\$28.11	\$8.20	\$18.30	\$0.00	\$54.61
6	75	\$30.12	\$8.20	\$18.83	\$0.00	\$57.15
7	80	\$32.13	\$8.20	\$19.35	\$0.00	\$59.68
8	90	\$36.14	\$8.20	\$20.40	\$0.00	\$64.74

Effective Date - 01/01/2020

Step	percent	Apprentice Base Wage	Health	Pension	Supplemental Unemployment	Total Rate
1	50	\$20.23	\$8.20	\$0.00	\$0.00	\$28.43
2	55	\$22.25	\$8.20	\$5.94	\$0.00	\$36.39
3	60	\$24.28	\$8.20	\$6.48	\$0.00	\$38.96
4	65	\$26.30	\$8.20	\$7.02	\$0.00	\$41.52
5	70	\$28.32	\$8.20	\$18.51	\$0.00	\$55.03
6	75	\$30.35	\$8.20	\$19.05	\$0.00	\$57.60
7	80	\$32.37	\$8.20	\$19.59	\$0.00	\$60.16
8	90	\$36.41	\$8.20	\$20.67	\$0.00	\$65.28

Notes:

Steps are 750 hrs.

Apprentice to Journeyworker Ratio:1:1

PAINTER / TAPER (BRUSH, REPAINT)	07/01/2019	\$38.22	\$8.20	\$21.45	\$0.00	\$67.87
PAINTERS LOCAL 35 - ZONE 2	01/01/2020	\$38.52	\$8.20	\$22.10	\$0.00	\$68.82
	07/01/2020	\$39.62	\$8.20	\$22.10	\$0.00	\$69.92
	01/01/2021	\$40.72	\$8.20	\$22.10	\$0.00	\$71.02

Classification

Effective Date Base Wage Health Pension Supplemental Unemployment Total Rate

Apprentice - PAINTER Local 35 Zone 2 - BRUSH REPAINT

Effective Date - 07/01/2019

Step	percent	Apprentice Base Wage	Health	Pension	Supplemental Unemployment	Total Rate
1	50	\$19.11	\$8.20	\$0.00	\$0.00	\$27.31
2	55	\$21.02	\$8.20	\$5.78	\$0.00	\$35.00
3	60	\$22.93	\$8.20	\$6.30	\$0.00	\$37.43
4	65	\$24.84	\$8.20	\$6.83	\$0.00	\$39.87
5	70	\$26.75	\$8.20	\$18.30	\$0.00	\$53.25
6	75	\$28.67	\$8.20	\$18.83	\$0.00	\$55.70
7	80	\$30.58	\$8.20	\$19.35	\$0.00	\$58.13
8	90	\$34.40	\$8.20	\$20.40	\$0.00	\$63.00

Effective Date - 01/01/2020

Step	percent	Apprentice Base Wage	Health	Pension	Supplemental Unemployment	Total Rate
1	50	\$19.26	\$8.20	\$0.00	\$0.00	\$27.46
2	55	\$21.19	\$8.20	\$5.94	\$0.00	\$35.33
3	60	\$23.11	\$8.20	\$6.48	\$0.00	\$37.79
4	65	\$25.04	\$8.20	\$7.02	\$0.00	\$40.26
5	70	\$26.96	\$8.20	\$18.51	\$0.00	\$53.67
6	75	\$28.89	\$8.20	\$19.05	\$0.00	\$56.14
7	80	\$30.82	\$8.20	\$19.59	\$0.00	\$58.61
8	90	\$34.67	\$8.20	\$20.67	\$0.00	\$63.54

Notes:
Steps are 750 hrs.

Apprentice to Journeyworker Ratio:1:1

PANEL & PICKUP TRUCKS DRIVER <i>TEAMSTERS JOINT COUNCIL NO. 10 ZONE A</i>	06/01/2019	\$35.18	\$11.91	\$12.70	\$0.00	\$59.79
	08/01/2019	\$35.18	\$12.41	\$12.70	\$0.00	\$60.29
	12/01/2019	\$35.18	\$12.41	\$13.72	\$0.00	\$61.31
	06/01/2020	\$36.08	\$12.41	\$13.72	\$0.00	\$62.21
	08/01/2020	\$36.08	\$12.91	\$13.72	\$0.00	\$62.71
	12/01/2020	\$36.08	\$12.91	\$14.82	\$0.00	\$63.81
	06/01/2021	\$36.88	\$12.91	\$14.82	\$0.00	\$64.61
	08/01/2021	\$36.88	\$13.41	\$14.82	\$0.00	\$65.11
	12/01/2021	\$36.88	\$13.41	\$16.01	\$0.00	\$66.30
PIER AND DOCK CONSTRUCTOR (UNDERPINNING AND DECK) <i>PILE DRIVER LOCAL 56 (ZONE 1)</i>	08/01/2018	\$46.57	\$9.90	\$21.15	\$0.00	\$77.62
<i>For apprentice rates see "Apprentice- PILE DRIVER"</i>	08/01/2019	\$48.94	\$9.90	\$21.15	\$0.00	\$79.99
PILE DRIVER <i>PILE DRIVER LOCAL 56 (ZONE 1)</i>	08/01/2018	\$46.57	\$9.90	\$21.15	\$0.00	\$77.62
	08/01/2019	\$48.94	\$9.90	\$21.15	\$0.00	\$79.99

Apprentice - PILE DRIVER - Local 56 Zone 1

Effective Date - 08/01/2018

Step	percent	Apprentice Base Wage	Health	Pension	Supplemental Unemployment	Total Rate
1	50	\$23.29	\$9.90	\$21.15	\$0.00	\$54.34
2	60	\$27.94	\$9.90	\$21.15	\$0.00	\$58.99
3	70	\$32.60	\$9.90	\$21.15	\$0.00	\$63.65
4	75	\$34.93	\$9.90	\$21.15	\$0.00	\$65.98
5	80	\$37.26	\$9.90	\$21.15	\$0.00	\$68.31
6	80	\$37.26	\$9.90	\$21.15	\$0.00	\$68.31
7	90	\$41.91	\$9.90	\$21.15	\$0.00	\$72.96
8	90	\$41.91	\$9.90	\$21.15	\$0.00	\$72.96

Effective Date - 08/01/2019

Step	percent	Apprentice Base Wage	Health	Pension	Supplemental Unemployment	Total Rate
1	50	\$24.47	\$9.90	\$21.15	\$0.00	\$55.52
2	60	\$29.36	\$9.90	\$21.15	\$0.00	\$60.41
3	70	\$34.26	\$9.90	\$21.15	\$0.00	\$65.31
4	75	\$36.71	\$9.90	\$21.15	\$0.00	\$67.76
5	80	\$39.15	\$9.90	\$21.15	\$0.00	\$70.20
6	80	\$39.15	\$9.90	\$21.15	\$0.00	\$70.20
7	90	\$44.05	\$9.90	\$21.15	\$0.00	\$75.10
8	90	\$44.05	\$9.90	\$21.15	\$0.00	\$75.10

Notes:

Apprentice to Journeyworker Ratio:1:5

PIPEFITTER & STEAMFITTER	03/01/2019	\$53.19	\$10.95	\$19.74	\$0.00	\$83.88
PIPEFITTERS LOCAL 537	09/01/2019	\$54.69	\$10.95	\$19.74	\$0.00	\$85.38
	03/01/2020	\$56.19	\$10.95	\$19.74	\$0.00	\$86.88
	09/01/2020	\$57.69	\$10.95	\$19.74	\$0.00	\$88.38
	03/01/2021	\$59.19	\$10.95	\$19.74	\$0.00	\$89.88

Classification

Effective Date Base Wage Health Pension Supplemental Unemployment Total Rate

Apprentice - PIPEFITTER - Local 537

Effective Date - 03/01/2019

Step	percent	Apprentice Base Wage	Health	Pension	Supplemental Unemployment	Total Rate
1	40	\$21.28	\$10.95	\$8.00	\$0.00	\$40.23
2	45	\$23.94	\$10.95	\$19.74	\$0.00	\$54.63
3	60	\$31.91	\$10.95	\$19.74	\$0.00	\$62.60
4	70	\$37.23	\$10.95	\$19.74	\$0.00	\$67.92
5	80	\$42.55	\$10.95	\$19.74	\$0.00	\$73.24

Effective Date - 09/01/2019

Step	percent	Apprentice Base Wage	Health	Pension	Supplemental Unemployment	Total Rate
1	40	\$21.88	\$10.95	\$8.00	\$0.00	\$40.83
2	45	\$24.61	\$10.95	\$19.74	\$0.00	\$55.30
3	60	\$32.81	\$10.95	\$19.74	\$0.00	\$63.50
4	70	\$38.28	\$10.95	\$19.74	\$0.00	\$68.97
5	80	\$43.75	\$10.95	\$19.74	\$0.00	\$74.44

Notes:
 ** 1:3; 3:15; 1:10 thereafter / Steps are 1 yr.
 Refrig/AC Mechanic **1:1;1:2;2:4;3:6;4:8;5:10;6:12;7:14;8:17;9:20;10:23(Max)

Apprentice to Journeyworker Ratio:**

PIPELAYER	06/01/2019	\$39.40	\$7.85	\$15.85	\$0.00	\$63.10
LABORERS - ZONE 1	12/01/2019	\$40.40	\$7.85	\$15.85	\$0.00	\$64.10
	06/01/2020	\$41.39	\$7.85	\$15.85	\$0.00	\$65.09
	12/01/2020	\$42.37	\$7.85	\$15.85	\$0.00	\$66.07
	06/01/2021	\$43.39	\$7.85	\$15.85	\$0.00	\$67.09
	12/01/2021	\$44.40	\$7.85	\$15.85	\$0.00	\$68.10

For apprentice rates see "Apprentice- LABORER"

PLUMBERS & GASFITTERS	03/01/2019	\$56.69	\$11.82	\$16.51	\$0.00	\$85.02
PLUMBERS & GASFITTERS LOCAL 12	09/01/2019	\$58.19	\$11.82	\$16.51	\$0.00	\$86.52
	03/01/2020	\$59.69	\$11.82	\$16.51	\$0.00	\$88.02
	09/01/2020	\$61.19	\$11.82	\$16.51	\$0.00	\$89.52
	03/01/2021	\$62.69	\$11.82	\$16.51	\$0.00	\$91.02

Classification

Effective Date Base Wage Health Pension Supplemental Unemployment Total Rate

Apprentice - PLUMBER/GASFITTER - Local 12

Effective Date - 03/01/2019

Step	percent	Apprentice Base Wage	Health	Pension	Supplemental Unemployment	Total Rate
1	35	\$19.84	\$11.82	\$5.98	\$0.00	\$37.64
2	40	\$22.68	\$11.82	\$6.79	\$0.00	\$41.29
3	55	\$31.18	\$11.82	\$9.25	\$0.00	\$52.25
4	65	\$36.85	\$11.82	\$10.85	\$0.00	\$59.52
5	75	\$42.52	\$11.82	\$12.50	\$0.00	\$66.84

Effective Date - 09/01/2019

Step	percent	Apprentice Base Wage	Health	Pension	Supplemental Unemployment	Total Rate
1	35	\$20.37	\$11.82	\$5.98	\$0.00	\$38.17
2	40	\$23.28	\$11.82	\$6.79	\$0.00	\$41.89
3	55	\$32.00	\$11.82	\$9.25	\$0.00	\$53.07
4	65	\$37.82	\$11.82	\$10.85	\$0.00	\$60.49
5	75	\$43.64	\$11.82	\$12.50	\$0.00	\$67.96

Notes:

** 1:2; 2:6; 3:10; 4:14; 5:19/Steps are 1 yr
Step4 with lic\$63.17, Step5 with lic\$70.47

Apprentice to Journeyworker Ratio:**

PNEUMATIC CONTROLS (TEMP.)	03/01/2019	\$53.19	\$10.95	\$19.74	\$0.00	\$83.88
PIPEFITTERS LOCAL 537	09/01/2019	\$54.69	\$10.95	\$19.74	\$0.00	\$85.38
	03/01/2020	\$56.19	\$10.95	\$19.74	\$0.00	\$86.88
	09/01/2020	\$57.69	\$10.95	\$19.74	\$0.00	\$88.38
	03/01/2021	\$59.17	\$10.95	\$19.74	\$0.00	\$89.86

For apprentice rates see "Apprentice- PIPEFITTER" or "PLUMBER/PIPEFITTER"

PNEUMATIC DRILL/TOOL OPERATOR	06/01/2019	\$39.40	\$7.85	\$15.85	\$0.00	\$63.10
LABORERS - ZONE 1	12/01/2019	\$40.40	\$7.85	\$15.85	\$0.00	\$64.10
	06/01/2020	\$41.39	\$7.85	\$15.85	\$0.00	\$65.09
	12/01/2020	\$42.37	\$7.85	\$15.85	\$0.00	\$66.07
	06/01/2021	\$43.39	\$7.85	\$15.85	\$0.00	\$67.09
	12/01/2021	\$44.40	\$7.85	\$15.85	\$0.00	\$68.10

For apprentice rates see "Apprentice- LABORER"

POWDERMAN & BLASTER	06/01/2019	\$40.15	\$7.85	\$15.85	\$0.00	\$63.85
LABORERS - ZONE 1	12/01/2019	\$41.15	\$7.85	\$15.85	\$0.00	\$64.85
	06/01/2020	\$42.14	\$7.85	\$15.85	\$0.00	\$65.84
	12/01/2020	\$43.12	\$7.85	\$15.85	\$0.00	\$66.82
	06/01/2021	\$44.14	\$7.85	\$15.85	\$0.00	\$67.84
	12/01/2021	\$45.15	\$7.85	\$15.85	\$0.00	\$68.85

For apprentice rates see "Apprentice- LABORER"

Classification	Effective Date	Base Wage	Health	Pension	Supplemental Unemployment	Total Rate
POWER SHOVEL/DERRICK/TRENCHING MACHINE <i>OPERATING ENGINEERS LOCAL 4</i>	06/01/2019	\$48.18	\$12.00	\$15.60	\$0.00	\$75.78
	12/01/2019	\$49.33	\$12.00	\$15.60	\$0.00	\$76.93
	06/01/2020	\$50.43	\$12.00	\$15.60	\$0.00	\$78.03
	12/01/2020	\$51.58	\$12.00	\$15.60	\$0.00	\$79.18
	06/01/2021	\$52.68	\$12.00	\$15.60	\$0.00	\$80.28
	12/01/2021	\$53.83	\$12.00	\$15.60	\$0.00	\$81.43
For apprentice rates see "Apprentice- OPERATING ENGINEERS"						
PUMP OPERATOR (CONCRETE) <i>OPERATING ENGINEERS LOCAL 4</i>	06/01/2019	\$48.18	\$12.00	\$15.60	\$0.00	\$75.78
	12/01/2019	\$49.33	\$12.00	\$15.60	\$0.00	\$76.93
	06/01/2020	\$50.43	\$12.00	\$15.60	\$0.00	\$78.03
	12/01/2020	\$51.58	\$12.00	\$15.60	\$0.00	\$79.18
	06/01/2021	\$52.68	\$12.00	\$15.60	\$0.00	\$80.28
	12/01/2021	\$53.83	\$12.00	\$15.60	\$0.00	\$81.43
For apprentice rates see "Apprentice- OPERATING ENGINEERS"						
PUMP OPERATOR (DEWATERING, OTHER) <i>OPERATING ENGINEERS LOCAL 4</i>	06/01/2019	\$32.28	\$12.00	\$15.60	\$0.00	\$59.88
	12/01/2019	\$33.07	\$12.00	\$15.60	\$0.00	\$60.67
	06/01/2020	\$33.82	\$12.00	\$15.60	\$0.00	\$61.42
	12/01/2020	\$34.60	\$12.00	\$15.60	\$0.00	\$62.20
	06/01/2021	\$35.35	\$12.00	\$15.60	\$0.00	\$62.95
	12/01/2021	\$36.14	\$12.00	\$15.60	\$0.00	\$63.74
For apprentice rates see "Apprentice- OPERATING ENGINEERS"						
READY MIX CONCRETE DRIVERS after 4/30/10 (Drivers Hired After 4/30/2010) <i>TEAMSTERS 25 (Metro) - Aggregate</i>	05/01/2018	\$24.15	\$9.28	\$13.59	\$0.00	\$47.02
READY-MIX CONCRETE DRIVER <i>TEAMSTERS 25 (Metro) - Aggregate</i>	05/01/2018	\$30.66	\$9.28	\$13.59	\$0.00	\$53.53
RECLAIMERS <i>OPERATING ENGINEERS LOCAL 4</i>	06/01/2019	\$47.69	\$12.00	\$15.60	\$0.00	\$75.29
	12/01/2019	\$48.83	\$12.00	\$15.60	\$0.00	\$76.43
	06/01/2020	\$49.91	\$12.00	\$15.60	\$0.00	\$77.51
	12/01/2020	\$51.05	\$12.00	\$15.60	\$0.00	\$78.65
	06/01/2021	\$52.14	\$12.00	\$15.60	\$0.00	\$79.74
	12/01/2021	\$53.28	\$12.00	\$15.60	\$0.00	\$80.88
For apprentice rates see "Apprentice- OPERATING ENGINEERS"						
RIDE-ON MOTORIZED BUGGY OPERATOR <i>LABORERS - ZONE 1</i>	06/01/2019	\$39.40	\$7.85	\$15.85	\$0.00	\$63.10
	12/01/2019	\$40.40	\$7.85	\$15.85	\$0.00	\$64.10
	06/01/2020	\$41.39	\$7.85	\$15.85	\$0.00	\$65.09
	12/01/2020	\$42.37	\$7.85	\$15.85	\$0.00	\$66.07
	06/01/2021	\$43.39	\$7.85	\$15.85	\$0.00	\$67.09
	12/01/2021	\$44.40	\$7.85	\$15.85	\$0.00	\$68.10
For apprentice rates see "Apprentice- LABORER"						
ROLLER/SPREADER/MULCHING MACHINE <i>OPERATING ENGINEERS LOCAL 4</i>	06/01/2019	\$47.69	\$12.00	\$15.60	\$0.00	\$75.29
	12/01/2019	\$48.83	\$12.00	\$15.60	\$0.00	\$76.43
	06/01/2020	\$49.91	\$12.00	\$15.60	\$0.00	\$77.51
	12/01/2020	\$51.05	\$12.00	\$15.60	\$0.00	\$78.65
	06/01/2021	\$52.14	\$12.00	\$15.60	\$0.00	\$79.74
	12/01/2021	\$53.28	\$12.00	\$15.60	\$0.00	\$80.88
For apprentice rates see "Apprentice- OPERATING ENGINEERS"						

Classification	Effective Date	Base Wage	Health	Pension	Supplemental Unemployment	Total Rate
ROOFER (Inc.Roofing Waterproofing &Roofing Damproofing) ROOFERS LOCAL 33	02/01/2019	\$43.36	\$11.50	\$15.90	\$0.00	\$70.76

Apprentice - ROOFER - Local 33

Effective Date - 02/01/2019

Step	percent	Apprentice Base Wage	Health	Pension	Supplemental Unemployment	Total Rate
1	50	\$21.68	\$11.50	\$3.69	\$0.00	\$36.87
2	60	\$26.02	\$11.50	\$15.90	\$0.00	\$53.42
3	65	\$28.18	\$11.50	\$15.90	\$0.00	\$55.58
4	75	\$32.52	\$11.50	\$15.90	\$0.00	\$59.92
5	85	\$36.86	\$11.50	\$15.90	\$0.00	\$64.26

Notes: ** 1:5, 2:6-10, the 1:10; Reroofing: 1:4, then 1:1
 Step 1 is 2000 hrs.; Steps 2-5 are 1000 hrs.
 (Hot Pitch Mechanics' receive \$1.00 hr. above ROOFER)

Apprentice to Journeyworker Ratio:**

ROOFER SLATE / TILE / PRECAST CONCRETE ROOFERS LOCAL 33	02/01/2019	\$43.61	\$11.50	\$15.90	\$0.00	\$71.01
--	------------	---------	---------	---------	--------	---------

For apprentice rates see "Apprentice- ROOFER"

SHEETMETAL WORKER SHEETMETAL WORKERS LOCAL 17 - A	02/01/2019	\$46.50	\$13.20	\$24.12	\$2.52	\$86.34
	08/01/2019	\$48.10	\$13.20	\$24.12	\$2.56	\$87.98
	02/01/2020	\$49.75	\$13.20	\$24.12	\$2.61	\$89.68
	08/01/2020	\$51.35	\$13.20	\$24.12	\$2.66	\$91.33
	02/01/2021	\$53.00	\$13.20	\$24.12	\$2.71	\$93.03
	08/01/2021	\$54.75	\$13.20	\$24.12	\$2.76	\$94.83
	02/01/2022	\$56.50	\$13.20	\$24.12	\$2.81	\$96.63

Apprentice - SHEET METAL WORKER - Local 17-A

Effective Date - 02/01/2019

Step	percent	Apprentice Base Wage	Health	Pension	Supplemental Unemployment	Total Rate
1	42	\$19.53	\$13.20	\$5.89	\$0.00	\$38.62
2	42	\$19.53	\$13.20	\$5.89	\$0.00	\$38.62
3	47	\$21.86	\$13.20	\$11.13	\$1.39	\$47.58
4	47	\$21.86	\$13.20	\$11.13	\$1.39	\$47.58
5	52	\$24.18	\$13.20	\$12.08	\$1.48	\$50.94
6	52	\$24.18	\$13.20	\$12.33	\$1.49	\$51.20
7	60	\$27.90	\$13.20	\$13.70	\$1.64	\$56.44
8	65	\$30.23	\$13.20	\$14.65	\$1.74	\$59.82
9	75	\$34.88	\$13.20	\$16.56	\$1.94	\$66.58
10	85	\$39.53	\$13.20	\$17.96	\$2.12	\$72.81

Effective Date - 08/01/2019

Step	percent	Apprentice Base Wage	Health	Pension	Supplemental Unemployment	Total Rate
1	42	\$20.20	\$13.20	\$5.89	\$0.00	\$39.29
2	42	\$20.20	\$13.20	\$5.89	\$0.00	\$39.29
3	47	\$22.61	\$13.20	\$11.13	\$1.41	\$48.35
4	47	\$22.61	\$13.20	\$11.13	\$1.41	\$48.35
5	52	\$25.01	\$13.20	\$12.08	\$1.51	\$51.80
6	52	\$25.01	\$13.20	\$12.33	\$1.52	\$52.06
7	60	\$28.86	\$13.20	\$13.70	\$1.67	\$57.43
8	65	\$31.27	\$13.20	\$14.65	\$1.77	\$60.89
9	75	\$36.08	\$13.20	\$16.56	\$1.98	\$67.82
10	85	\$40.89	\$13.20	\$17.96	\$2.16	\$74.21

Notes:
Steps are 6 mos.

Apprentice to Journeyworker Ratio:1:4

SPECIALIZED EARTH MOVING EQUIP < 35 TONS TEAMSTERS JOINT COUNCIL NO. 10 ZONE A	06/01/2019	\$35.64	\$11.91	\$12.70	\$0.00	\$60.25
	08/01/2019	\$35.64	\$12.41	\$12.70	\$0.00	\$60.75
	12/01/2019	\$35.64	\$12.41	\$13.72	\$0.00	\$61.77
	06/01/2020	\$36.54	\$12.41	\$13.72	\$0.00	\$62.67
	08/01/2020	\$36.54	\$12.91	\$13.72	\$0.00	\$63.17
	12/01/2020	\$36.54	\$12.91	\$14.82	\$0.00	\$64.27
	06/01/2021	\$37.34	\$12.91	\$14.82	\$0.00	\$65.07
	08/01/2021	\$37.34	\$13.41	\$14.82	\$0.00	\$65.57
	12/01/2021	\$37.34	\$13.41	\$16.01	\$0.00	\$66.76

Classification	Effective Date	Base Wage	Health	Pension	Supplemental Unemployment	Total Rate
SPECIALIZED EARTH MOVING EQUIP > 35 TONS <i>TEAMSTERS JOINT COUNCIL NO. 10 ZONE A</i>	06/01/2019	\$35.93	\$11.91	\$12.70	\$0.00	\$60.54
	08/01/2019	\$35.93	\$12.41	\$12.70	\$0.00	\$61.04
	12/01/2019	\$35.93	\$12.41	\$13.72	\$0.00	\$62.06
	06/01/2020	\$36.83	\$12.41	\$13.72	\$0.00	\$62.96
	08/01/2020	\$36.83	\$12.91	\$13.72	\$0.00	\$63.46
	12/01/2020	\$36.83	\$12.91	\$14.82	\$0.00	\$64.56
	06/01/2021	\$37.63	\$12.91	\$14.82	\$0.00	\$65.36
	08/01/2021	\$37.63	\$13.41	\$14.82	\$0.00	\$65.86
	12/01/2021	\$37.63	\$13.41	\$16.01	\$0.00	\$67.05
SPRINKLER FITTER <i>SPRINKLER FITTERS LOCAL 550 - (Section A) Zone 1</i>	03/01/2019	\$58.98	\$9.47	\$19.60	\$0.00	\$88.05
	10/01/2019	\$60.48	\$9.47	\$19.60	\$0.00	\$89.55
	03/01/2020	\$61.98	\$9.47	\$19.60	\$0.00	\$91.05
	10/01/2020	\$63.48	\$9.47	\$19.60	\$0.00	\$92.55
	03/01/2021	\$64.98	\$9.47	\$19.60	\$0.00	\$94.05

Classification

Effective Date Base Wage Health Pension Supplemental Unemployment Total Rate

Apprentice - SPRINKLER FITTER - Local 550 (Section A) Zone 1

Effective Date - 03/01/2019

Step	percent	Apprentice Base Wage	Health	Pension	Supplemental Unemployment	Total Rate
1	35	\$20.64	\$9.47	\$9.10	\$0.00	\$39.21
2	40	\$23.59	\$9.47	\$9.10	\$0.00	\$42.16
3	45	\$26.54	\$9.47	\$9.10	\$0.00	\$45.11
4	50	\$29.49	\$9.47	\$9.10	\$0.00	\$48.06
5	55	\$32.44	\$9.47	\$9.10	\$0.00	\$51.01
6	60	\$35.39	\$9.47	\$10.60	\$0.00	\$55.46
7	65	\$38.34	\$9.47	\$10.60	\$0.00	\$58.41
8	70	\$41.29	\$9.47	\$10.60	\$0.00	\$61.36
9	75	\$44.24	\$9.47	\$10.60	\$0.00	\$64.31
10	80	\$47.18	\$9.47	\$10.60	\$0.00	\$67.25

Effective Date - 10/01/2019

Step	percent	Apprentice Base Wage	Health	Pension	Supplemental Unemployment	Total Rate
1	35	\$21.17	\$9.47	\$9.10	\$0.00	\$39.74
2	40	\$24.19	\$9.47	\$9.10	\$0.00	\$42.76
3	45	\$27.22	\$9.47	\$9.10	\$0.00	\$45.79
4	50	\$30.24	\$9.47	\$9.10	\$0.00	\$48.81
5	55	\$33.26	\$9.47	\$9.10	\$0.00	\$51.83
6	60	\$36.29	\$9.47	\$10.60	\$0.00	\$56.36
7	65	\$39.31	\$9.47	\$10.60	\$0.00	\$59.38
8	70	\$42.34	\$9.47	\$10.60	\$0.00	\$62.41
9	75	\$45.36	\$9.47	\$10.60	\$0.00	\$65.43
10	80	\$48.38	\$9.47	\$10.60	\$0.00	\$68.45

Notes: Apprentice entered prior 9/30/10:
40/45/50/55/60/65/70/75/80/85
Steps are 850 hours

Apprentice to Journeyworker Ratio:1:3

STEAM BOILER OPERATOR <i>OPERATING ENGINEERS LOCAL 4</i>	06/01/2019	\$47.69	\$12.00	\$15.60	\$0.00	\$75.29
	12/01/2019	\$48.83	\$12.00	\$15.60	\$0.00	\$76.43
	06/01/2020	\$49.91	\$12.00	\$15.60	\$0.00	\$77.51
	12/01/2020	\$51.05	\$12.00	\$15.60	\$0.00	\$78.65
	06/01/2021	\$52.14	\$12.00	\$15.60	\$0.00	\$79.74
	12/01/2021	\$53.28	\$12.00	\$15.60	\$0.00	\$80.88

For apprentice rates see "Apprentice- OPERATING ENGINEERS"

TAMPERS, SELF-PROPELLED OR TRACTOR DRAWN <i>OPERATING ENGINEERS LOCAL 4</i>	06/01/2019	\$47.69	\$12.00	\$15.60	\$0.00	\$75.29
	12/01/2019	\$48.83	\$12.00	\$15.60	\$0.00	\$76.43
	06/01/2020	\$49.91	\$12.00	\$15.60	\$0.00	\$77.51
	12/01/2020	\$51.05	\$12.00	\$15.60	\$0.00	\$78.65
	06/01/2021	\$52.14	\$12.00	\$15.60	\$0.00	\$79.74
	12/01/2021	\$53.28	\$12.00	\$15.60	\$0.00	\$80.88

For apprentice rates see "Apprentice- OPERATING ENGINEERS"

Classification	Effective Date	Base Wage	Health	Pension	Supplemental Unemployment	Total Rate
TELECOMMUNICATION TECHNICIAN <i>ELECTRICIANS LOCAL 103</i>	03/01/2019	\$38.33	\$13.00	\$16.82	\$0.00	\$68.15

Apprentice - TELECOMMUNICATION TECHNICIAN - Local 103

Effective Date - 03/01/2019

Step	percent	Apprentice Base Wage	Health	Pension	Supplemental Unemployment	Total Rate
1	40	\$15.33	\$13.00	\$0.46	\$0.00	\$28.79
2	40	\$15.33	\$13.00	\$0.46	\$0.00	\$28.79
3	45	\$17.25	\$13.00	\$13.42	\$0.00	\$43.67
4	45	\$17.25	\$13.00	\$13.42	\$0.00	\$43.67
5	50	\$19.17	\$13.00	\$13.73	\$0.00	\$45.90
6	55	\$21.08	\$13.00	\$14.03	\$0.00	\$48.11
7	60	\$23.00	\$13.00	\$14.34	\$0.00	\$50.34
8	65	\$24.91	\$13.00	\$14.66	\$0.00	\$52.57
9	70	\$26.83	\$13.00	\$14.96	\$0.00	\$54.79
10	75	\$28.75	\$13.00	\$15.27	\$0.00	\$57.02

Notes:

Apprentice to Journeyworker Ratio:1:1

TERRAZZO FINISHERS <i>BRICKLAYERS LOCAL 3 - MARBLE & TILE</i>	02/01/2019	\$52.49	\$10.75	\$20.66	\$0.00	\$83.90
	08/01/2019	\$53.34	\$10.75	\$21.30	\$0.00	\$85.39
	02/01/2020	\$53.98	\$10.75	\$21.30	\$0.00	\$86.03
	08/01/2020	\$55.33	\$10.75	\$21.45	\$0.00	\$87.53
	02/01/2021	\$55.97	\$10.75	\$21.45	\$0.00	\$88.17
	08/01/2021	\$57.37	\$10.75	\$21.61	\$0.00	\$89.73
	02/01/2022	\$57.96	\$10.75	\$21.61	\$0.00	\$90.32

Classification

Effective Date Base Wage Health Pension Supplemental Unemployment Total Rate

Apprentice - TERRAZZO FINISHER - Local 3 Marble & Tile

Effective Date - 02/01/2019

Step	percent	Apprentice Base Wage	Health	Pension	Supplemental Unemployment	Total Rate
1	50	\$26.25	\$10.75	\$20.03	\$0.00	\$57.03
2	60	\$31.49	\$10.75	\$20.03	\$0.00	\$62.27
3	70	\$36.74	\$10.75	\$20.03	\$0.00	\$67.52
4	80	\$41.99	\$10.75	\$20.03	\$0.00	\$72.77
5	90	\$47.24	\$10.75	\$20.03	\$0.00	\$78.02

Effective Date - 08/01/2019

Step	percent	Apprentice Base Wage	Health	Pension	Supplemental Unemployment	Total Rate
1	50	\$26.67	\$10.75	\$21.30	\$0.00	\$58.72
2	60	\$32.00	\$10.75	\$21.30	\$0.00	\$64.05
3	70	\$37.34	\$10.75	\$21.30	\$0.00	\$69.39
4	80	\$42.67	\$10.75	\$21.30	\$0.00	\$74.72
5	90	\$48.01	\$10.75	\$21.30	\$0.00	\$80.06

Notes:

Apprentice to Journeyworker Ratio:1:3

TEST BORING DRILLER <i>LABORERS - FOUNDATION AND MARINE</i>	06/01/2019	\$40.50	\$7.85	\$16.05	\$0.00	\$64.40
	12/01/2019	\$41.50	\$7.85	\$16.05	\$0.00	\$65.40
	06/01/2020	\$42.49	\$7.85	\$16.05	\$0.00	\$66.39
	12/01/2020	\$43.47	\$7.85	\$16.05	\$0.00	\$67.37
	06/01/2021	\$44.49	\$7.85	\$16.05	\$0.00	\$68.39
	12/01/2021	\$45.50	\$7.85	\$16.05	\$0.00	\$69.40

For apprentice rates see "Apprentice- LABORER"

TEST BORING DRILLER HELPER <i>LABORERS - FOUNDATION AND MARINE</i>	06/01/2019	\$39.22	\$7.85	\$16.05	\$0.00	\$63.12
	12/01/2019	\$40.22	\$7.85	\$16.05	\$0.00	\$64.12
	06/01/2020	\$41.21	\$7.85	\$16.05	\$0.00	\$65.11
	12/01/2020	\$42.19	\$7.85	\$16.05	\$0.00	\$66.09
	06/01/2021	\$43.21	\$7.85	\$16.05	\$0.00	\$67.11
	12/01/2021	\$44.22	\$7.85	\$16.05	\$0.00	\$68.12

For apprentice rates see "Apprentice- LABORER"

TEST BORING LABORER <i>LABORERS - FOUNDATION AND MARINE</i>	06/01/2019	\$39.10	\$7.85	\$16.05	\$0.00	\$63.00
	12/01/2019	\$40.10	\$7.85	\$16.05	\$0.00	\$64.00
	06/01/2020	\$41.09	\$7.85	\$16.05	\$0.00	\$64.99
	12/01/2020	\$42.07	\$7.85	\$16.05	\$0.00	\$65.97
	06/01/2021	\$43.09	\$7.85	\$16.05	\$0.00	\$66.99
	12/01/2021	\$44.10	\$7.85	\$16.05	\$0.00	\$68.00

For apprentice rates see "Apprentice- LABORER"

Classification	Effective Date	Base Wage	Health	Pension	Supplemental Unemployment	Total Rate
TRACTORS/PORTABLE STEAM GENERATORS <i>OPERATING ENGINEERS LOCAL 4</i>	06/01/2019	\$47.69	\$12.00	\$15.60	\$0.00	\$75.29
	12/01/2019	\$48.83	\$12.00	\$15.60	\$0.00	\$76.43
	06/01/2020	\$49.91	\$12.00	\$15.60	\$0.00	\$77.51
	12/01/2020	\$51.05	\$12.00	\$15.60	\$0.00	\$78.65
	06/01/2021	\$52.14	\$12.00	\$15.60	\$0.00	\$79.74
	12/01/2021	\$53.28	\$12.00	\$15.60	\$0.00	\$80.88
For apprentice rates see "Apprentice- OPERATING ENGINEERS"						
TRAILERS FOR EARTH MOVING EQUIPMENT <i>TEAMSTERS JOINT COUNCIL NO. 10 ZONE A</i>	06/01/2019	\$36.22	\$11.91	\$12.70	\$0.00	\$60.83
	08/01/2019	\$36.22	\$12.41	\$12.70	\$0.00	\$61.33
	12/01/2019	\$36.22	\$12.41	\$13.72	\$0.00	\$62.35
	06/01/2020	\$37.12	\$12.41	\$13.72	\$0.00	\$63.25
	08/01/2020	\$37.12	\$12.91	\$13.72	\$0.00	\$63.75
	12/01/2020	\$37.12	\$12.91	\$14.82	\$0.00	\$64.85
	06/01/2021	\$37.92	\$12.91	\$14.82	\$0.00	\$65.65
	08/01/2021	\$37.92	\$13.41	\$14.82	\$0.00	\$66.15
12/01/2021	\$37.92	\$13.41	\$16.01	\$0.00	\$67.34	
TUNNEL WORK - COMPRESSED AIR <i>LABORERS (COMPRESSED AIR)</i>	06/01/2019	\$51.38	\$7.85	\$16.45	\$0.00	\$75.68
	12/01/2019	\$52.38	\$7.85	\$16.45	\$0.00	\$76.68
	06/01/2020	\$53.37	\$7.85	\$16.45	\$0.00	\$77.67
	12/01/2020	\$54.35	\$7.85	\$16.45	\$0.00	\$78.65
	06/01/2021	\$55.37	\$7.85	\$16.45	\$0.00	\$79.67
	12/01/2021	\$56.38	\$7.85	\$16.45	\$0.00	\$80.68
For apprentice rates see "Apprentice- LABORER"						
TUNNEL WORK - COMPRESSED AIR (HAZ. WASTE) <i>LABORERS (COMPRESSED AIR)</i>	06/01/2019	\$53.38	\$7.85	\$16.45	\$0.00	\$77.68
	12/01/2019	\$54.38	\$7.85	\$16.45	\$0.00	\$78.68
	06/01/2020	\$55.37	\$7.85	\$16.45	\$0.00	\$79.67
	12/01/2020	\$56.35	\$7.85	\$16.45	\$0.00	\$80.65
	06/01/2021	\$57.37	\$7.85	\$16.45	\$0.00	\$81.67
	12/01/2021	\$58.38	\$7.85	\$16.45	\$0.00	\$82.68
For apprentice rates see "Apprentice- LABORER"						
TUNNEL WORK - FREE AIR <i>LABORERS (FREE AIR TUNNEL)</i>	06/01/2019	\$43.45	\$7.85	\$16.45	\$0.00	\$67.75
	12/01/2019	\$44.45	\$7.85	\$16.45	\$0.00	\$68.75
	06/01/2020	\$45.44	\$7.85	\$16.45	\$0.00	\$69.74
	12/01/2020	\$46.42	\$7.85	\$16.45	\$0.00	\$70.72
	06/01/2021	\$47.44	\$7.85	\$16.45	\$0.00	\$71.74
	12/01/2021	\$48.45	\$7.85	\$16.45	\$0.00	\$72.75
For apprentice rates see "Apprentice- LABORER"						
TUNNEL WORK - FREE AIR (HAZ. WASTE) <i>LABORERS (FREE AIR TUNNEL)</i>	06/01/2019	\$45.45	\$7.85	\$16.45	\$0.00	\$69.75
	12/01/2019	\$46.45	\$7.85	\$16.45	\$0.00	\$70.75
	06/01/2020	\$47.44	\$7.85	\$16.45	\$0.00	\$71.74
	12/01/2020	\$48.42	\$7.85	\$16.45	\$0.00	\$72.72
	06/01/2021	\$49.44	\$7.85	\$16.45	\$0.00	\$73.74
	12/01/2021	\$50.45	\$7.85	\$16.45	\$0.00	\$74.75
For apprentice rates see "Apprentice- LABORER"						

Classification	Effective Date	Base Wage	Health	Pension	Supplemental Unemployment	Total Rate
VAC-HAUL <i>TEAMSTERS JOINT COUNCIL NO. 10 ZONE A</i>	06/01/2019	\$35.64	\$11.91	\$12.70	\$0.00	\$60.25
	08/01/2019	\$35.64	\$12.41	\$12.70	\$0.00	\$60.75
	12/01/2019	\$35.64	\$12.41	\$13.72	\$0.00	\$61.77
	06/01/2020	\$36.54	\$12.41	\$13.72	\$0.00	\$62.67
	08/01/2020	\$36.54	\$12.91	\$13.72	\$0.00	\$63.17
	12/01/2020	\$36.54	\$12.91	\$14.82	\$0.00	\$64.27
	06/01/2021	\$37.34	\$12.91	\$14.82	\$0.00	\$65.07
	08/01/2021	\$37.34	\$13.41	\$14.82	\$0.00	\$65.57
	12/01/2021	\$37.34	\$13.41	\$16.01	\$0.00	\$66.76
WAGON DRILL OPERATOR <i>LABORERS - ZONE 1</i>	06/01/2019	\$39.40	\$7.85	\$15.85	\$0.00	\$63.10
	12/01/2019	\$40.40	\$7.85	\$15.85	\$0.00	\$64.10
	06/01/2020	\$41.39	\$7.85	\$15.85	\$0.00	\$65.09
	12/01/2020	\$42.37	\$7.85	\$15.85	\$0.00	\$66.07
	06/01/2021	\$43.39	\$7.85	\$15.85	\$0.00	\$67.09
	12/01/2021	\$44.40	\$7.85	\$15.85	\$0.00	\$68.10
For apprentice rates see "Apprentice- LABORER"						
WASTE WATER PUMP OPERATOR <i>OPERATING ENGINEERS LOCAL 4</i>	06/01/2019	\$48.18	\$12.00	\$15.60	\$0.00	\$75.78
	12/01/2019	\$49.33	\$12.00	\$15.60	\$0.00	\$76.93
	06/01/2020	\$50.43	\$12.00	\$15.60	\$0.00	\$78.03
	12/01/2020	\$51.58	\$12.00	\$15.60	\$0.00	\$79.18
	06/01/2021	\$52.68	\$12.00	\$15.60	\$0.00	\$80.28
	12/01/2021	\$53.83	\$12.00	\$15.60	\$0.00	\$81.43
For apprentice rates see "Apprentice- OPERATING ENGINEERS"						
WATER METER INSTALLER <i>PLUMBERS & GASFITTERS LOCAL 12</i>	03/01/2019	\$56.69	\$11.82	\$16.51	\$0.00	\$85.02
	09/01/2019	\$58.19	\$11.82	\$16.51	\$0.00	\$86.52
	03/01/2020	\$59.69	\$11.82	\$16.51	\$0.00	\$88.02
	09/01/2020	\$61.19	\$11.82	\$16.51	\$0.00	\$89.52
	03/01/2021	\$62.69	\$11.82	\$16.51	\$0.00	\$91.02
For apprentice rates see "Apprentice- PLUMBER/PIPEFITTER" or "PLUMBER/GASFITTER"						
Outside Electrical - East						
CABLE TECHNICIAN (Power Zone) <i>OUTSIDE ELECTRICAL WORKERS - EAST LOCAL 104</i>	09/03/2017	\$27.14	\$7.75	\$1.81	\$0.00	\$36.70
For apprentice rates see "Apprentice- LINEMAN"						
CABLEMAN (Underground Ducts & Cables) <i>OUTSIDE ELECTRICAL WORKERS - EAST LOCAL 104</i>	09/03/2017	\$38.45	\$7.75	\$9.53	\$0.00	\$55.73
For apprentice rates see "Apprentice- LINEMAN"						
DRIVER / GROUNDMAN CDL <i>OUTSIDE ELECTRICAL WORKERS - EAST LOCAL 104</i>	09/03/2017	\$31.66	\$7.75	\$9.44	\$0.00	\$48.85
For apprentice rates see "Apprentice- LINEMAN"						
DRIVER / GROUNDMAN -Inexperienced (<2000 Hrs) <i>OUTSIDE ELECTRICAL WORKERS - EAST LOCAL 104</i>	09/03/2017	\$24.88	\$7.75	\$1.75	\$0.00	\$34.38
For apprentice rates see "Apprentice- LINEMAN"						
EQUIPMENT OPERATOR (Class A CDL) <i>OUTSIDE ELECTRICAL WORKERS - EAST LOCAL 104</i>	09/03/2017	\$38.45	\$7.75	\$13.61	\$0.00	\$59.81
For apprentice rates see "Apprentice- LINEMAN"						
EQUIPMENT OPERATOR (Class B CDL) <i>OUTSIDE ELECTRICAL WORKERS - EAST LOCAL 104</i>	09/03/2017	\$33.92	\$7.75	\$10.21	\$0.00	\$51.88
For apprentice rates see "Apprentice- LINEMAN"						

Classification	Effective Date	Base Wage	Health	Pension	Supplemental Unemployment	Total Rate
GROUNDMAN <i>OUTSIDE ELECTRICAL WORKERS - EAST LOCAL 104</i>	09/03/2017	\$24.88	\$7.75	\$1.75	\$0.00	\$34.38
For apprentice rates see "Apprentice- LINEMAN"						
GROUNDMAN -Inexperienced (<2000 Hrs.) <i>OUTSIDE ELECTRICAL WORKERS - EAST LOCAL 104</i>	09/03/2017	\$20.35	\$7.75	\$1.61	\$0.00	\$29.71
For apprentice rates see "Apprentice- LINEMAN"						
JOURNEYMAN LINEMAN <i>OUTSIDE ELECTRICAL WORKERS - EAST LOCAL 104</i>	09/03/2017	\$45.23	\$7.75	\$16.61	\$0.00	\$69.59

Apprentice - LINEMAN (Outside Electrical) - East Local 104

Effective Date - 09/03/2017

Step	percent	Apprentice Base Wage	Health	Pension	Supplemental Unemployment	Total Rate
1	60	\$27.14	\$7.75	\$3.31	\$0.00	\$38.20
2	65	\$29.40	\$7.75	\$3.38	\$0.00	\$40.53
3	70	\$31.66	\$7.75	\$3.45	\$0.00	\$42.86
4	75	\$33.92	\$7.75	\$5.02	\$0.00	\$46.69
5	80	\$36.18	\$7.75	\$5.09	\$0.00	\$49.02
6	85	\$38.45	\$7.75	\$5.15	\$0.00	\$51.35
7	90	\$40.71	\$7.75	\$7.22	\$0.00	\$55.68

Notes:

Apprentice to Journeyworker Ratio:1:2

TELEDATA CABLE SPLICER <i>OUTSIDE ELECTRICAL WORKERS - EAST LOCAL 104</i>	02/04/2019	\$30.73	\$4.70	\$3.17	\$0.00	\$38.60
TELEDATA LINEMAN/EQUIPMENT OPERATOR <i>OUTSIDE ELECTRICAL WORKERS - EAST LOCAL 104</i>	02/04/2019	\$28.93	\$4.70	\$3.14	\$0.00	\$36.77
TELEDATA WIREMAN/INSTALLER/TECHNICIAN <i>OUTSIDE ELECTRICAL WORKERS - EAST LOCAL 104</i>	02/04/2019	\$28.93	\$4.70	\$3.14	\$0.00	\$36.77
TREE TRIMMER <i>OUTSIDE ELECTRICAL WORKERS - EAST LOCAL 104</i>	01/31/2016	\$18.51	\$3.55	\$0.00	\$0.00	\$22.06
This classification applies only to tree work done: (a) for a utility company, R.E.A. cooperative, or railroad or coal mining company, and (b) for the purpose of operating, maintaining, or repairing the utility company's equipment, and (c) by a person who is using hand or mechanical cutting methods and is not on the ground. This classification does not apply to wholesale tree removal.						
TREE TRIMMER GROUNDMAN <i>OUTSIDE ELECTRICAL WORKERS - EAST LOCAL 104</i>	01/31/2016	\$16.32	\$3.55	\$0.00	\$0.00	\$19.87

This classification applies only to tree work done: (a) for a utility company, R.E.A. cooperative, or railroad or coal mining company, and (b) for the purpose of operating, maintaining, or repairing the utility company's equipment, and (c) by a person who is using hand or mechanical cutting methods and is on the ground. This classification does not apply to wholesale tree removal.

Additional Apprentices Information:

Minimum wage rates for apprentices employed on public works projects are listed above as a percentage of the pre-determined hourly wage rate established by the Commissioner under the provisions of the M.G.L. c. 149, ss. 26-27D. Apprentices ratios are established by the Division of Apprenticeship Training pursuant to M.G.L. c. 23, ss. 11E-11L.

All apprentices must be registered with the Division of Apprenticeship Training in accordance with M.G.L. c. 23, ss. 11E-11L.

All steps are six months (1000 hours.)

Ratios are expressed in allowable number of apprentices to journeymen or fraction thereof, unless otherwise specified.

** Multiple ratios are listed in the comment field.

*** APP to JM; 1:1, 2:2, 2:3, 3:4, 4:4, 4:5, 4:6, 5:7, 6:7, 6:8, 6:9, 7:10, 8:10, 8:11, 8:12, 9:13, 10:13, 10:14, etc.

**** APP to JM; 1:1, 1:2, 2:3, 2:4, 3:5, 4:6, 4:7, 5:8, 6:9, 6:10, 7:11, 8:12, 8:13, 9:14, 10:15, 10:16, etc.

FORM A

CERTIFICATE OF NON-COLLUSION

The undersigned certifies under penalties of perjury that this bid is in all respects bona fide, fir and made without collusion or fraud with any other person. As used in this section the word 'person' shall mean any natural person, joint venture, partnership, corporation or other business or legal entity.

Authorized Name

Authorized Signature Date

Social Security Number or Federal Identification Number

Legal Name of Business Entity (Print or

Type) Address

City, State, Zip Code

Corporate Seal (If applicable)

FORM B

CERTIFICATE OF FOREIGN CORPORATION

The undersigned certifies that it has been duly established, organized, or chartered as a corporation under the laws of:

Jurisdiction

The undersigned further certifies that it complies with the requirements of M.G.L, c. 30, sec. 39L and with the requirements of M.G.L, c. 181 relative to the registration and operation of foreign corporations within the Commonwealth of Massachusetts.

Name of Person Signing the Bid or Proposal Date

Signature of Person Signing the Bid or Proposal Date

Name of Business (Print or Type)

Corporate Seal (If applicable)

FORMD

BIDDER CERTIFICATION REGARDING PAYMENT OF PREVAILING WAGES

The undersigned hereby certifies, under pains and penalties of perjury, that the foregoing bid is based upon the payment to laborers to be employed on the project of wages in an amount no less than the applicable wage rates established for the project by the Massachusetts Department of Labor and Industries. The undersigned bidder agrees to identify the awarding authority for, from, and against any loss, expense, damages, action, or claims, including any expense incurred in connection with any delay or stoppage of the project work, arising out of or as a result of (1) the failure of the said bid to be based upon the payment of the said applicable prevailing wage rates or (2) the failure of the bidder, if selected as the contractor, to pay laborers employed on the project the said applying prevailing wage rates.

Date

Name of Person Signing the Bid or Proposal

Signature of Person Signing the Bid or Proposal Title

Name of Business (Print or Type)

Corporate Seal (If applicable)

FORM E

CERTIFICATION OF PAYMENT OF STATE TAXES

Legislation enacted by the Commonwealth of Massachusetts, effective, 1983, requires that attestation below be signed:

Pursuant to M.G.L c. 62C, sec. 49A, I certify under the penalties of perjury, that I, to my best knowledge and belief, have filed all state tax returns and paid all state taxes required by law.

APPROVAL OF A CONTRACT OR ANY OTHER AGREEMENT WILL NOT BE GRANTED UNLESS THIS CERTIFICATION CLAUSE IS SIGNED BY AN AUTHORIZED CORPORATE OFFICER.

THE TAX PAYER IDENTIFICATION NUMBER WILL BE FURNISHED TO THE MASSACHUSETTS DEPARTMENT OF REVENUE TO DETERMINE IF TAX FILINGS AND/OR TAX PAYMENT OBLIGATIONS HAVE BEEN MET. PROVIDERS WHO FAIL TO CORRECT THEIR NON-FILING AND/OR DELIQUENCY STATUS SHALL NOT HAVE A CONTRACT OR ANY OTHER AGREEMENT ISSUED, RENEWED OR EXTENDED

(Signature of Individual)

Title

Social Security Number or Federal Identification Number

Corporate Name

Name of Person Signing the Proposal (Print or Type)

Date

Legal Name of Business Entity (Print or

Type) Business Address

Corporate Seal (If applicable)

FORM F

**CERTIFICATION OF AUTHORITY
MEETING OF BOARD OF
DIRECTORS**

(Note: if business entity is a partnership or individual, all owners shall sign this form.)

At a meeting of the Directors of the _____ duly called and held at

(Corporation)

_____ on the _____ day of _____, 20 _____,
(Location)

at which a quorum was present and acting, it was voted that _____, the
(Name)

_____ of this Corporation, is hereby authorized and empowered to make,
(Title/Position)

into, sign, seal and deliver on behalf of the Corporation a Contract for _____
with the _____, and the performance and payment
bonds each in the amount as specified by the Owner.

I hereby certify that the above is a true and correct copy of the record, that said vote has not been amended or repealed and is in full force, and effect as of this date and that

_____ is duly elected _____ of the corporation
(Name) (Title/Position)

Clerk or secretary of the Corporation

Date

(Note: If the Bidder is a corporation, affix corporate seal and give below the names of its president, treasurer, and general manager, if any: if a partnership, give full names and residential addresses of all partners; and if an individual, give residential address if different from business address.)

the required names and addresses of all person interested in this proposal, as Principals, are as follows:

CONTRACT FOR RGTG'UEJ QQN'RNC[I TQWPF'TGPQXCVIQP AGREEMENT

THIS AGREEMENT, made as of this _____ day of _____, 20____, by and between the TOWN OF ARLINGTON, MASSACHUSETTS, acting through its TOWN

MANAGER, hereinafter called the 'Owner' and _____, (Name of Contractor) of _____, country of _____ and State of _____, hereinafter called the 'Contractor'.

WITNESSETH; That the Contractor and the Owner for the consideration hereinafter named agrees as follow:

1. SCOPE: The Contractor will furnish at his own proper cost and expense all materials, supplies, machinery, equipment, appliances, tools, superintendence, labor, insurance and other items and services necessary to complete the work as shown and described on the Contract Documents entitled "Rgtteg School Playground Renovatiop. Arlington, Massachusetts, hereinafter called the 'Project', prepared by Weston & Sampson Engineers, Inc., hereinafter called the 'Designer', or 'Landscape Architect'.
2. CONTRACT SUM: The owner agrees to pay the contractor, and the contractor agrees to accept in full consideration for the performance of the contract, subject to additions and deductions provided for in the contract documents, in current funds, the sum of dollars (\$ _____), hereinafter called the 'Contract Sum' and to make payments on account thereof, as described below and elsewhere in the Contract Documents.
3. COMMENCEMENT OF WORK AND TIME OF COMPLETION: The contractor agrees to commence work on the contract within seven (7) calendar days from the receipt of written Notice to Proceed issued by the Owner and/or within fourteen (14) calendar days after execution of the contract Agreement and to thereafter diligently and continuously carry on the work. He agrees to complete the work on or before November 22, 2019 except as herein noted.
4. LIQUIDATED DAMAGES: The Contractor agrees to pay the Owner liquidated damages for failure to complete the Project in conformance with the time allowances as set forth above at the rate of \$100.00 per calendar day.
5. ALTERNATES: The following Alternates have been accepted and the Contract Sum stated in Paragraph 2 of this Agreement includes and is adjusted to reflect the total cost of each accepted alternate:

Alternate No.	Indicate Accepted or Rejected	Original Bid Value of Alternate
ADD Alt. No. 1	_____	_____
ADD Alt. No. 2	_____	_____
ADD Alt. No. 3	_____	_____
ADD Alt. No. 4	_____	_____

6. PAYMENTS TO CONTRACTOR: Payments shall be made in accordance with Chapter 30, Section 39K of the General Laws of the Commonwealth of Massachusetts, including all current amendments, generally as follows:

- A. Within fifteen days after receipt from the Contractor, at the place designated by the Owner if such a place is so designated, of a periodic estimate requesting payment of the amount due for the preceding month, the Owner will make a periodic payment to the Contractor for the work performed during the preceding month and for the materials not incorporated in the work but delivered and suitably stored at the site (or at some location agreed upon in writing) to which the Contractor has title or to which a subcontractor has title and has authorized the Contractor to transfer title to the Owner, less (1) a retention based on its estimate of the fair value of its claims against the Contractor and less (2) a retention for direct payments to subcontractors based on demands for same in accordance with the provisions of Section 39F, and less (3) a retention not exceeding five percent of the approved amount of the periodic payment. After the receipt of a periodic estimate requesting final payment and within sixty-five days after (a) the Contractor fully completes the work or substantially completes the work so that the value of the work remaining to be done is, in the estimate of the Owner, less than one percent of the original contract price, or (b) the Contractor substantially completes the work and the Owner takes possession for occupancy, whichever occurs first, the Owner shall pay the Contractor the entire balance due on the Contract less (1) a retention based on its estimate of the fair value of its claim against the Contractor and of the cost of completing the incomplete and unsatisfactory items of work and less (2) a retention for direct payments to subcontractors based on the demands for same in accordance with the provisions of Section 39F, or based on the record of payments by the Contractor to the subcontractors under this contract if such record of payment indicates that the Contractor has not paid subcontractors as provided in Section 39F. If the Owner fails to make payment as herein provided, there shall be added to each such payment daily interest at the rate of five percent per annum commencing on the first day after said payment is due and continuing until the payment is delivered or mailed to the Contractor, provided, that no interest shall be due, in any event, on the amount due on a periodic estimate for Final Payment until fifteen days after receipt of such a periodic estimate from the Contractor, at the place designated by the Owner if such a place is so designated. The Contractor agrees to pay to each subcontractor a portion of any such interest paid in accordance with the amount due each subcontractor.
- B. The Owner may make changes in any periodic estimate submitted by the Contractor and the payment due on said periodic estimate shall be computed in accordance with the changes so made, but such changes or any requirement for a corrected periodic estimate shall not affect the due date for the periodic payment or the date for the commencement of interest charges on the amount of the periodic payment computed in accordance with the changes made, as provided herein; provided that the Owner may, within seven days after receipt, return to the Contractor for correction any periodic estimate which is not in the required form or which contains computations not arithmetically correct and, in that event, the date of receipt for such periodic estimate in proper form and with arithmetically correct computations. The date of receipt of a periodic estimate received on a Saturday shall be the first working day thereafter. The provisions of Section 39G shall not apply to any contract for the construction, reconstruction, remodeling, repair or demolition of any public building to which this section applies.
7. **PAYMENTS TO SUBCONTRACTORS:** Payments shall be made in accordance with Chapter 30, Section 39F of the General Laws of the Commonwealth of Massachusetts, including all current amendments, generally as follows:

- A. Forthwith after the General Contractor receives payment on account of a period estimate, the General Contractor shall pay to each Subcontractor the amount paid for the labor performed and the materials furnished in any court proceedings barring such payment and also less any amount claimed due from the Subcontractor by the General Contractor.
- B. Not later than the sixty-fifth day after each Subcontractor substantially completes his work in accordance with the plans and specifications, the entire balance due under the Subcontract less amounts retained by the Owner as the estimated cost of completing the incomplete and unsatisfactory items of work, shall be due the Subcontractor, and the Owner shall pay that amount to the General Contractor. The General Contractor shall forthwith pay to the Subcontractor the full amount received from the Owner less any amount specified in any court proceedings barring such payment and also less any amount claimed due from the Subcontractor by the General Contractor.
- C. Each payment made by the Owner to the General Contractor pursuant to subparagraphs (A) and (B) of this paragraph for the labor performed and the materials furnished by a Subcontractor shall be made to the General Contractor for the account of that Subcontractor; and the Owner shall take reasonable steps to compel the General Contractor to make each payment to each such Subcontractor. If the Owner has received a demand for direct payment from a Subcontractor for any amount which has already been included in a payment to the General Contractor for payment to the Subcontractor as provided in subparagraphs (A) and (B), the Owner shall act upon demand as provided in this Section.
- D. If, within seventy days after the Subcontractor has substantially completed the Subcontract work, the Subcontractor has not received from the General Contractor the balance due under the Subcontract including any amount due for extra labor and materials furnished to the General Contractor, less any amount retained by the Owner as the estimated cost of completing the incomplete and unsatisfactory items of work, the Subcontractor may demand direct payment of that balance from the Owner. The demand shall be by a sworn statement delivered to or sent by certified mail to the Owner, and a copy shall be delivered to or sent by certified mail to the General Contractor at the same time. The demand shall contain a detailed breakdown of the balance due under the Subcontract and also a statement of the status of completion of the Subcontract work. Any demand made after Substantial Completion of the Subcontract work shall be valid even if delivered or mailed prior to the seventieth day after the Subcontractor has substantially completed the Subcontract work. Within ten days after the Subcontractor has delivered or so mailed the demand to the Owner and delivered or so mailed a copy to the General Contractor, the General Contractor may reply to the demand. The reply shall be a sworn statement delivered to or sent by certified mail to the Owner and a copy shall be delivered to or sent by certified mail to the Subcontractor at the same time. The reply shall contain a detailed breakdown of the balance due under the Subcontract including any amount due for extra labor and materials furnished to the General Contractor and of the amount due for each claim made by the General Contractor against the Subcontractor.
- E. Within fifteen days after receipt of the demand by the Owner, but in no event prior to the seventieth day after Substantial Completion of the Subcontract work, the Awarding Authority shall make direct payment to the Subcontractor of the balance due under the Subcontract, less any amount (i) retained by the Owner as the estimated cost of completing the incomplete or unsatisfactory items of work, (ii) specified in any court proceedings barring such payment, or (iii) disputed by the General Contractor in the sworn reply: provided, that the Owner shall not deduct from a direct payment any amount as provided in part (iii) if the reply is not sworn to, or for which the sworn reply does not contain the detailed breakdown required in subparagraph (D); The Owner shall make further direct payments to the Subcontractor forthwith after the removal of the basis for deductions from direct payments made as provided in parts (i) and (ii) of this

subparagraph.

- F. The Owner shall forthwith deposit the amount deducted from a direct payment as provided in part (iii) of subparagraph (E) in an interest-bearing joint account in the names of the General Contractor and the Subcontractor in a bank in Massachusetts; selected by the Owner and agreed upon by the General Contractor and the Subcontractor and shall notify the General Contractor and the Subcontractor of the date of deposit and the bank receiving the deposit. The bank shall pay the amount on the account, including accrued interest, as provided in an agreement between the General Contractor and the Subcontractor or as determined by decree of a court of competent jurisdiction.
- G. All direct payments and all deductions from demands for direct payments deposited in an interest-bearing account or accounts in a bank pursuant to subparagraph (F) shall be made out of amounts payable to the General Contractor at the time of receipt of a demand for direct payment from a Subcontractor and out of amounts later become payable to the General Contractor and in order of receipt of such demands from Subcontractors. All direct payments shall discharge the obligation of the Owner to the General Contractor to the extent of such payment.
- H. The Owner shall deduct from payments to a General Contractor amounts which, together with the deposits in interest-bearing accounts pursuant to subparagraph (F), are sufficient to satisfy all unpaid balances of demands for direct payment received from Subcontractors. All such amounts shall be earmarked for such direct payments, and the Subcontractors shall have a right in such deductions prior to any claims against such amounts by creditors of the General Contractor.
- I. On all contracts for building construction subject to the provisions of Sections 44A to 44L, inclusive, of Chapter 149, periodic payments for work performed by a Subcontractor shall be made to the General Contractor for payment to the Subcontractor and shall be paid to the Subcontractor forthwith after receipt thereof by the General Contractor and without any ten day waiting period as provided above, less any amount claimed by the General Contractor in a letter containing a breakdown of the claim and sent to the Subcontractor with such payment, provided that a General Contractor, who has received a periodic estimate for a periodic payment in proper form from a Subcontractor three days, Saturdays, Sundays and holidays excluded, before the due date of the General Contractor's periodic estimate for the same periodic payment period less any amount claimed by the General Contractor in a letter containing a breakdown of the claim and sent to the Subcontractor with such payment, even though the General Contractor does not submit a periodic estimate to the Owner for that payment period; and provided, further, that the Owner shall take all reasonable steps to compel the General Contractor to make payment to the Subcontractors as provided in this paragraph, and upon the written request of a Subcontractor setting forth the amount payable but not paid, a copy of which shall be sent to the General Contractor, shall make direct payment to a Subcontractor, as provided for above, which shall discharge the obligation of the Owner to the General Contractor to extent of any such payment.
- J. The Owner shall not include in any direct payment to a Subcontractor pursuant to this section any amount claimed from that Subcontractor by the General Contractor in a letter containing a breakdown of the claim and sent to the Owner within ten days after the receipt by the General Contractor of the copy of the request of the Subcontractor to the Owner for direct payment.

8. CONDITIONS OF EMPLOYMENT

- A. The schedule of Minimum Wage Rates and Health and Pension Fund Contributions as determined by the Commissioner under the provisions of the Massachusetts General Laws, Chapter 149, Sections 26 m 27D, inclusive, AS amended, is hereby made a part of this Agreement.

- B. The Contractor shall pay to any reserve police officer employed by him in any city or town the prevailing rate of wages paid to regular police officers in such city or town.
- C. No laborer, workman, mechanic, foreman or inspector working within the Commonwealth, in the employ of the Contractor, Subcontractor or any other person doing or contracting to do the whole or a part of the work contemplated by the Contract, shall be required or permitted to work more than eight hours in any one day or forty-eight hours in any one week, or more than six days in any one week, except in cases of emergency.
- D. Every employee of the Contractor or any Subcontractor shall lodge, board and trade where and with whom he elects; and no person or his agents or employees shall be directly or indirectly required, as a condition of employment that the employee to lodge, board or trade at a particular place or with a particular person.

9. SUBCONTRACTORS

- A. The Contractor will employ the following Subcontractors on the work and will pay for the execution of his as defined in the Contract Documents; and subject to the additions and deductions provided in the subject to the additions and deductions provided in the Contract Documents, the sum shown opposite his name.

<u>Class Of Work</u>	<u>Subcontractor</u>	<u>Subcontractor Sum</u>

- B. The names of any additional Subcontractors whom the Contractor proposed to employ shall be submitted to the Designer for approval. No such Subcontractor shall be employed to whose standing or ability the Owner or the Designer has any reasonable objection.

10. THE CONTRACT DOCUMENTS: The General Conditions of the Contract, the Specifications and the Drawings, together with this Agreement, for the Contract, and they are as fully a part of the Contract as if hereto attached or herein repeated Drawings and Specifications titled: HARDY SCHOOL PLAYGROUND RENOVATION.

11. INCORPORATION OF STATUTES BY REFERENCE: If statutes of the Commonwealth of Massachusetts in any way relating to the construction, alterations, repair and installation of public works,

particularly with reference to labor and labor rates, they shall be strictly complied with by the Contractor and it is understood that all such statutes are incorporated by reference in this Contract.

- 12. It is expressly agreed that this Agreement is to be executed for and in behalf of the Owner by the members of its Board of Selectmen and any of its appoints and that such persons are acting in a representative capacity for and in behalf of Owner, and that such persons shall not incur any personal liability hereunder.

IN WITNESS whereof, inhabitants of the Town of Arlington and

have caused these presents to be executed by their

hereunto duly authorized the day and year first written.

TOWN OF ARLINGTON

Adam W. Chapdelaine, Town Manager

Certification:
I hereby Certify that an appropriation in the amount of the Contract is available.

Town Accountant

Contractor

By: . (Title)

Approved as to Matter of Form:

Town Counsel

PERFORMANCE BOND

KNOW ALL MEN BY THESE PRESENTS: That we

(Name of Contractor)

a _____
(Corporation, Partnership or Individual)

hereinafter called "Principal" and

(Surety)
of _____, State of _____, hereinafter called the
"Surety", are held and firmly bound into

THE TOWN OF ARLINGTON,
MASSACHUSETTS (Owner)

acting through its TOWN MANAGER

ARLINGTON,
MASSACHUSETTS (City and
State)

hereinafter called "Owner", in the penal sum of
_____ Dollars (\$ _____) in lawful money
of the United states, for the payment of which sum well and truly to be made, we bind
ourselves, our heirs, executors, administrators and successors, jointly and severally, firmly
by these presents.

THE CONDITION OF THIS OBLIGATION is such that Whereas, the Principal entered into
a certain contract with the Owner, dated _____ day of _____ a copy
of which is hereto attached and made a part hereof for the construction of

Arlington, Massachusetts

NOW, THEREFORE, if the Principal shall well, truly and faithfully perform its duties, all
the undertakings, covenants, terms, conditions, and agreements of said contract during the
original term thereof, and any extensions thereof which may be granted by, the Owner, with
or without notice to the Surety, and if he shall satisfy all claims and demands incurred under
such contract, and shall fully indemnify and save harmless the Owner from all costs and
damages which it may suffer by reason of failure to do so, and shall reimburse and repay
the Owner all outlay and expense which the Owner may incur in making good any default,
then this obligation shall be void; otherwise to remain in full force and effect.

PROVIDED, FURTHER, that the said Surety, for value received hereby stipulates and agrees that no change, extension of time, alteration or addition to the terms of the Contract or to the work to be performed thereunder or the specifications accompanying the same shall in any way affect its obligation of this, Bond, and it does hereby waive notice of any such change, extension of time, alteration or addition to the terms of the contract or to the work or to the specifications.

PROVIDED, FURTHER, that no final settlement between the Owner and the Contractor shall abridge the right of any beneficiary hereunder, whose claim may be unsatisfied.

IN WITNESS WHEREOF, the parties to these present have duly executed in this Bond on the day of _____

ATTEST:

Principal

By _____
Secretary

(Address - zip code)

Witness as to Principal

(Seal)

(Address - zip code)

ATTEST

: Surety

BY _____

(Surety)

Secretary

(Address-Zip Code)

Witness as to Surety

(Seal)

(Address-Zip Code)

NOTE: Date of Bond must not be prior to date of Contract. If Contractor is a Partnership, all partners should execute Bond.

END OF DOCUMENT

LABOR AND MATERIALS PAYMENT BOND

KNOW ALL MEN BY THESE PRESENTS: That we

_____ (Name of Contractor)

a _____ (Corporation, Partnership of Individual)

hereinafter called "Principal" and

_____ (Surety)

of _____, State of _____, hereinafter called the "Surety", are held and firmly bound into

TOWN OF ARLINGTON,
MASSACHUSETTS (Owner)
acting through its TOWN MANAGER

ARLINGTON,
MASSACHUSETTS (City and State)

herein called "Owner", in the penal sum of

_____, Dollars (\$) in lawful money of the United States, for the payment of which sum well and truly to be made, we bind ourselves, our heirs, executors, administrators and successors, jointly and severally, firmly by these presents.

THE CONDITION OF THIS OBLIGATION is such that 'Whereas, the Principal entered into a certain contract with the Owner, dated the day of _____, _____ a copy of which is hereto attached and made a part hereof for the construction of:

SPY POND EGDE AND EROSION CONTROL PROJECT IN ARLINGTON
MASSACHUSETTS.

NOW, THEREFORE, if the Principal shall promptly make payment to all persons, firms, subcontractors, and corporations furnishing materials for or performing labor in the prosecution of the work provided for in such contract, and any authorized extension or modification thereof, including all amounts due for materials, lubricants, oil, gasoline, coal and coke, repairs on machinery, equipment and tools, consumed or used 'in connection with the construction of such work, and all insurance premiums on said work, and for all labor, performed in such work whether by subcontractor or otherwise, then this obligation shall be void; otherwise to remain in full force and effect.

PROVIDED, FURTHER, that the said surety, for value received hereby stipulates and agrees that no change, extension of time, alteration or addition to the terms of the contract or to the work to be performed thereunder or the specifications accompanying the Same shall in any wise affect its obligation on this Bond, and it does hereby waive notice of any such change, extension of time, alteration or addition to the terms of the contract or to the work or to the specifications.

PROVIDED, FURTHER, that no final settlement between the Owner and the Contractor shall abridge the right of any beneficiary hereunder, whose claim may be unsatisfied.

IN WITNESS WHEREOF, the parties to these present have duly executed in this Bond on the day of _____,

ATTEST:

Principal

BY
Secretary

(Address - zip code)

Witness as to Principal

(Seal)

(Address - zip code)

ATTEST:

Surety

Secretary

(Address-Zip Code)

Witness as to Surety

(Seal)

(Address-Zip Code)

NOTE: Date of Bond must not be prior to date of Contract. If Contractor is a Partnership, all partners should execute Bond.

END OF DOCUMENT

BY-LAWS OF THE TOWN OF ARLINGTON
TITLE I
ARTICLE 16

CONSTRUCTION PROJECTS

Section 1. Women Work Force Participation

Any Town board or official in charge of a construction or reconstruction project is required to include in the contract documents the following:

- A. Contractor shall maintain as a goal on this project a not less than five percent ratio of women work force to total project hours in both the general contract and each individual filed sub-bid contract, if applicable. The preceding sentence shall be included in all construction contracts whether entered into by the Town pursuant to the provisions of M.G.L. c. 149 or M.G. L. c 30, §39M et. seq. provided however, that if entered into under Chapter 30 same shall not be deemed to apply where the projected bid price as determined by the Director of Public Works is not likely to exceed \$200,000.
- B. A Labor Scheduling Table which will be used as a tool for achieving a range of women work force participation for the entire project in both the general contract and each individual filed sub-bid contract.

Section 2. Equal Opportunity Goal Compliance

Any Town board or official in charge of a construction or reconstruction project is required to include in the contract documents the following:

- A. Before starting work, the contractors (includes the general contractor, for itself and its subcontractors, as well as all filed sub-bid contractors, if applicable) will submit plans for achievement of the equal opportunity goals of the contract. All contractors will be required to make a good faith effort to achieve these goals. The plan will indicate if the contractors expect to achieve the requirements during the first quarter. If there are reasons why the contractors do not expect to achieve the requirements during the first quarter year of the contract construction phase, then the contractors shall provide a plan calculated to address, to the extent reasonably possibly, these obstacles to a good faith effort to achieve such goals.
- B. Not more than ten days following the end of each work quarter, the contractors will report on the achievement of the goals, detailing the good faith efforts that have been made and will continue to be made and any other appropriate efforts not yet undertaken.
- C. All reports will be signed by an officer or principal of the company who has the authority to contractually obligate the company.

Section 3. Recruitment and Training

Any board, officer, committee, or other agency of the Town, which acts on behalf of the Town in making or supervising any contract, in an amount exceeding the sum of \$100,000 for the purchase of goods or services or for the construction, renovation, or repair of buildings or other improvement of real estate, may make arrangements with contractors and other interested agencies for special programs of recruitment and training in connection with the work to be performed on such contract, with the objective of promoting equal employment opportunity for members of minority groups protected by the fair employment laws of the Commonwealth and the United States. Any board, officer, committee or other Town agency may expend Town funds in carrying them out provided that appropriations specifically designed for such purposes have been voted by the Town Meeting.



TOWN OF ARLINGTON EQUAL OPPORTUNITY ADVISORY COMMITTEE

730 MASSACHUSETTS AVENUE, ARLINGTON, MA 02476
PHONE (781) 316-3120 FAX: (781) 316-3129

TRICIA O'DONOGHUE, CHAIR
BARBARA BOLTZ
AUGUSTA HAYDOCK
JACK JONES

CARYN COVE MALLOY
EQUAL OPPORTUNITY OFFICER

CONTRACTOR CERTIFICATION

During the performance of the Contract, the Contractor and all subcontractors (hereafter collectively referred to as "the Contractor") for a town construction contract or town assisted construction contract, for him/herself, his/her assignees and successors in interest, agree to comply with all applicable equal employment opportunity, non-discrimination and affirmative action requirements, including but not limited to the following:

The Contractor shall comply with the provisions of Town of Arlington Bylaws, Anti-Discrimination policies and Chapter 151B of the Massachusetts General Laws, as amended, and all other applicable anti-discrimination and equal opportunity laws, all of which are herein incorporated by reference and made a part of this contract.

In connection with the performance of work under this contract, the Contractor shall undertake, in good faith, affirmative action measures to eliminate any discriminatory barrier in the terms and conditions of employment on the grounds of race, color, religious creed, national origin, sex, gender identity, sexual orientation, age, genetic information, ancestry, children, marital status, veteran status or membership in the armed service, the receiving of public assistance, and handicap. Such affirmative action measures shall entail a list of positive and aggressive measures which shall include but not be limited to, advertising employment opportunities in minority and other community news media; notifying minority women and other community-based organizations of employment opportunities; maintaining a file of names and addresses of each worker referred to the Contractor and what action was taken concerning such worker; and notifying this Committee in writing when a union with whom the Contractor has a collective bargaining agreement has failed to refer a minority or woman worker.

The Contractor shall submit to the Equal Opportunity Advisory Committee, through the Purchasing Director Domenic Lanzillotti, the following Contractor's Certification with all attachments. The Contractor's Certification will be reviewed by the Committee and will inform the Contractor of any deficiencies to be corrected.

CONTRACTOR CERTIFICATION

_____ certifies that they:

(Contractor Name)

1. Will not discriminate in their employment practices.
2. Intend to use, if General Contractor, the following listed construction trades in the work under the contract:

3. If Trade Subcontractor, will provide the following work under the contract:

4. Will make good faith efforts to comply with the minority employee and women employee workforce participation ratio goals of the Town of Arlington and the Commonwealth of Massachusetts and specific affirmative steps contained herein; and to provide evidence of its good faith efforts. Attached hereto, please find:

- A. Employment Opportunities advertised in:

- B. Notification to Minority/Women/Community based Organizations such as:

C. List of workers referred to Contractor and note on what action was taken:

D. Written notification that Union/Local No. _____ failed to refer a Minority or
Female worker during the week of: _____

Signature of Officer

Date

Printed Name of Officer and Title

STANDARD
GENERAL CONDITIONS
OF THE
CONSTRUCTION CONTRACT

Prepared by

ENGINEERS JOINT CONTRACT DOCUMENTS COMMITTEE

and

Issued and Published Jointly By

PROFESSIONAL ENGINEERS IN PRIVATE PRACTICE
a practice division of the
NATIONAL SOCIETY OF PROFESSIONAL ENGINEERS

AMERICAN CONSULTING ENGINEERS COUNCIL

AMERICAN SOCIETY OF CIVIL ENGINEERS

This document has been approved and endorsed by

The Associated General

Contractors of America

Construction Specifications Institute

Copyright ©1996

National Society of Professional Engineers
1420 King Street, Alexandria, VA 22314

American Consulting Engineers Council
1015 15th Street N.W., Washington, DC 20005

American Society of Civil Engineers
345 East 47th Street, New York, NY 10017

TABLE OF CONTENTS

Page

ARTICLE 1 - DEFINITIONS AND TERMINOLOGY6
 1.01 *Defined Terms*6
 1.02 *Terminology*.....8

ARTICLE 2 - PRELIMINARY MATTERS9
 2.01 *Delivery of Bonds*.....9
 2.02 *Copies of Documents*.....9
 2.03 *Commencement of Contract Times; Notice to Proceed*9
 2.04 *Starting the Work*9
 2.05 *Before Starting Construction*9
 2.06 *Preconstruction Conference*.....10
 2.07 *Initial Acceptance of Schedules*.....10

ARTICLE 3 - CONTRACT DOCUMENTS: INTENT, AMENDING, REUSE.....10
 3.01 *Intent*10
 3.02 *Reference Standards*10
 3.03 *Reporting and Resolving Discrepancies*.....10
 3.04 *Amending and Supplementing Contract Documents*.....11
 3.05 *Reuse of Documents*.....11

ARTICLE 4 - AVAILABILITY OF LANDS; SUBSURFACE AND PHYSICAL CONDITIONS; REFERENCE
POINTS.....11
 4.01 *Availability of Lands*.....11
 4.02 *Subsurface and Physical Conditions*.....12
 4.03 *Differing Subsurface or Physical Conditions*.....12
 4.04 *Underground Facilities*.....13
 4.05 *Reference Points*13
 4.06 *Hazardous Environmental Condition at Site*.....14

ARTICLE 5 - BONDS AND INSURANCE.....15
 5.01 *Performance, Payment, and Other Bonds*15
 5.02 *Licensed Sureties and Insurers*15
 5.03 *Certificates of Insurance*15
 5.04 *CONTRACTOR’S Liability Insurance*15
 5.05 *OWNER’S Liability Insurance*16
 5.06 *Property Insurance*.....16
 5.07 *Waiver of Rights*17
 5.08 *Receipt and Application of Insurance Proceeds*18
 5.09 *Acceptance of Bonds and Insurance; Option to Replace*.....18
 5.10 *Partial Utilization, Acknowledgment of Property Insurer*18

ARTICLE 6 - CONTRACTOR’S RESPONSIBILITIES18
 6.01 *Supervision and Superintendence*18
 6.02 *Labor; Working Hours*.....19
 6.03 *Services, Materials, and Equipment*19
 6.04 *Progress Schedule*19
 6.05 *Substitutes and “Or-Equals”*19
 6.06 *Concerning Subcontractors, Suppliers, and Others*.....21

6.07 Patent Fees and Royalties	21
6.08 Permits	22
6.09 Laws and Regulations	22
6.10 Taxes	22
6.11 Use of Site and Other Areas.....	22
6.12 Record Documents.....	22
6.13 Safety and Protection	23
6.14 Safety Representative.....	23
6.15 Hazard Communication Programs.....	23
6.16 Emergencies.....	23
6.17 Shop Drawings and Samples.....	24
6.18 Continuing the Work	25
6.19 CONTRACTOR's General Warranty and Guarantee	25
6.20 Indemnification	25
ARTICLE 7 - OTHER WORK	26
7.01 Related Work at Site	26
7.02 Coordination.....	26
ARTICLE 8 - OWNER'S RESPONSIBILITIES	27
8.01 Communications to Contractor.....	27
8.02 Replacement of ENGINEER.....	27
8.03 Furnish Data	27
8.04 Pay Promptly When Due.....	27
8.05 Lands and Easements; Reports and Tests	27
8.06 Insurance.....	27
8.07 Change Orders	27
8.08 Inspections, Tests, and Approvals	27
8.09 Limitations on OWNER's Responsibilities.....	27
8.10 Undisclosed Hazardous Environmental Condition.....	27
8.11 Evidence of Financial Arrangements	27
ARTICLE 9 - ENGINEER'S STATUS DURING CONSTRUCTION.....	27
9.01 OWNER'S Representative	27
9.02 Visits to Site	28
9.03 Project Representative.....	28
9.04 Clarifications and Interpretations.....	28
9.05 Authorized Variations in Work	28
9.06 Rejecting Defective Work	29
9.07 Shop Drawings, Change Orders and Payments.....	29
9.08 Determinations for Unit Price Work.....	28
9.09 Decisions on Requirements of Contract Documents and Acceptability of Work	28
9.10 Limitations on ENGINEER's Authority and Responsibilities	28
ARTICLE 10 - CHANGES IN THE WORK; CLAIMS.....	29
10.01 Authorized Changes in the Work	29
10.02 Unauthorized Changes in the Work	29
10.03 Execution of Change Orders	30
10.04 Notification to Surety	30
10.05 Claims and Disputes	30
ARTICLE 11 - COST OF THE WORK; CASH ALLOWANCES; UNIT PRICE WORK.....	30
11.01 Cost of the Work.....	30

11.02	<i>Cash Allowances</i>	32
11.03	<i>Unit Price Work</i>	33
ARTICLE 12 - CHANGE OF CONTRACT PRICE; CHANGE OF CONTRACT TIMES.....33		
12.01	<i>Change of Contract Price</i>	33
12.02	<i>Change of Contract Times</i>	34
12.03	<i>Delays Beyond CONTRACTOR's Control</i>	34
12.04	<i>Delays Within CONTRACTOR's Control</i>	34
12.05	<i>Delays Beyond OWNER's and CONTRACTOR'S Control</i>	34
12.06	<i>Delay Damages</i>	34
ARTICLE 13 - TESTS AND INSPECTIONS; CORRECTION, REMOVAL OR ACCEPTANCE OF DEFECTIVE WORK.....34		
13.01	<i>Notice of Defects</i>	34
13.02	<i>Access to Work</i>	34
13.03	<i>Tests and Inspections</i>	35
13.04	<i>Uncovering Work</i>	35
13.05	<i>OWNER May Stop the Work</i>	35
13.06	<i>Correction or Removal of Defective Work</i>	36
13.07	<i>Correction Period</i>	36
13.08	<i>Acceptance of Defective Work</i>	36
13.09	<i>OWNER May Correct Defective Work</i>	36
ARTICLE 14 - PAYMENTS TO CONTRACTOR AND COMPLETION37		
14.01	<i>Schedule of Values</i>	37
14.02	<i>Progress Payments</i>	37
14.03	<i>CONTRACTOR's Warranty of Title</i>	38
14.04	<i>Substantial Completion</i>	39
14.05	<i>Partial Utilization</i>	39
14.06	<i>Final Inspection</i>	39
14.07	<i>Final Payment</i>	40
14.08	<i>Final Completion Delayed</i>	40
14.09	<i>Waiver of Claims</i>	41
ARTICLE 15 - SUSPENSION OF WORK AND TERMINATION.....41		
15.01	<i>OWNER May Suspend Work</i>	41
15.02	<i>OWNER May Terminate for Cause</i>	41
15.03	<i>OWNER May Terminate For Convenience</i>	41
15.04	<i>CONTRACTOR May Stop Work or Terminate</i>	42
ARTICLE 16 - DISPUTE RESOLUTION42		
16.01	<i>Methods and Procedures</i>	42
ARTICLE 17 - MISCELLANEOUS.....43		
17.01	<i>Giving Notice</i>	43
17.02	<i>Computation of Times</i>	43
17.03	<i>Cumulative Remedies</i>	43
17.04	<i>Survival of Obligations</i>	43
17.05	<i>Controlling Law</i>	43

GENERAL CONDITIONS

ARTICLE 1 - DEFINITIONS AND TERMINOLOGY

1.01 *Defined Terms*

A. Wherever used in the Contract Documents and printed with initial or all capital letters, the terms listed below will have the meanings indicated which are applicable to both the singular and plural thereof.

1. *Addenda*--Written or graphic instruments issued prior to the opening of Bids which clarify, correct, or change the Bidding Requirements or the Contract Documents.

2. *Agreement*--The written instrument which is evidence of the agreement between OWNER and CONTRACTOR covering the Work.

3. *Application for Payment*--The form acceptable to ENGINEER which is to be used by CONTRACTOR during the course of the Work in requesting progress or final payments and which is to be accompanied by such supporting documentation as is required by the Contract Documents.

4. *Asbestos*--Any material that contains more than one percent asbestos and is friable or is releasing asbestos fibers into the air above current action levels established by the United States Occupational Safety and Health Administration.

5. *Bid*--The offer or proposal of a bidder submitted on the prescribed form setting forth the prices for the Work to be performed.

6. *Bidding Documents*--The Bidding Requirements and the proposed Contract Documents (including all Addenda issued prior to receipt of Bids).

7. *Bidding Requirements*--The Advertisement or Invitation to Bid, Instructions to Bidders, Bid security form, if any, and the Bid form with any supplements.

8. *Bonds*--Performance and payment bonds and other instruments of security.

9. *Change Order*--A document recommended by ENGINEER which is signed by CONTRACTOR and OWNER and authorizes an addition, deletion, or revision in the Work or an adjustment in the Contract Price or the

Contract Times, issued on or after the Effective Date of the Agreement.

10. *Claim*--A demand or assertion by OWNER or CONTRACTOR seeking an adjustment of Contract Price or Contract Times, or both, or other relief with respect to the terms of the Contract. A demand for money or services by a third party is not a Claim.

11. *Contract*--The entire and integrated written agreement between the OWNER and CONTRACTOR concerning the Work. The Contract supersedes prior negotiations, representations, or agreements, whether written or oral.

12. *Contract Documents*--The Contract Documents establish the rights and obligations of the parties and include the Agreement, Addenda (which pertain to the Contract Documents), CONTRACTOR's Bid (including documentation accompanying the Bid and any post Bid documentation submitted prior to the Notice of Award) when attached as an exhibit to the Agreement, the Notice to Proceed, the Bonds, these General Conditions, the Supplementary Conditions, the Specifications and the Drawings as the same are more specifically identified in the Agreement, together with all Written Amendments, Change Orders, Work Change Directives, Field Orders, and ENGINEER's written interpretations and clarifications issued on or after the Effective Date of the Agreement. Approved Shop Drawings and the reports and drawings of subsurface and physical conditions are not Contract Documents. Only printed or hard copies of the items listed in this paragraph are Contract Documents. Files in electronic media format of text, data, graphics, and the like that may be furnished by OWNER to CONTRACTOR are not Contract Documents.

13. *Contract Price*--The moneys payable by OWNER to CONTRACTOR for completion of the Work in accordance with the Contract Documents as stated in the Agreement (subject to the provisions of paragraph 11.03 in the case of Unit Price Work).

14. *Contract Times*--The number of days or the dates stated in the Agreement to: (i) achieve Substantial Completion; and (ii) complete the Work so that it is ready for final payment as evidenced by ENGINEER's written recommendation of final payment.

15. *CONTRACTOR*--The individual or entity with whom OWNER has entered into the Agreement.

16. *Cost of the Work*--See paragraph 11.01.A for definition.

17. *Drawings*--That part of the Contract Documents prepared or approved by ENGINEER which graphically shows the scope, extent, and character of the Work to be performed by CONTRACTOR. Shop Drawings and other CONTRACTOR submittals are not Drawings as so defined.

18. *Effective Date of the Agreement*--The date indicated in the Agreement on which it becomes effective, but if no such date is indicated, it means the date on which the Agreement is signed and delivered by the last of the two parties to sign and deliver.

19. *ENGINEER*--The individual or entity named as such in the Agreement.

20. *ENGINEER's Consultant*--An individual or entity having a contract with ENGINEER to furnish services as ENGINEER's independent professional associate or consultant with respect to the Project and who is identified as such in the Supplementary Conditions.

21. *Field Order*--A written order issued by ENGINEER which requires minor changes in the Work but which does not involve a change in the Contract Price or the Contract Times.

22. *General Requirements*--Sections of Division 1 of the Specifications. The General Requirements pertain to all sections of the Specifications.

23. *Hazardous Environmental Condition*--The presence at the Site of Asbestos, PCBs, Petroleum, Hazardous Waste, or Radioactive Material in such quantities or circumstances that may present a substantial danger to persons or property exposed thereto in connection with the Work.

24. *Hazardous Waste*--The term Hazardous Waste shall have the meaning provided in Section 1004 of the Solid Waste Disposal Act (42 USC Section 6903) as amended from time to time.

25. *Laws and Regulations; Laws or Regulations*--Any and all applicable laws, rules, regulations, ordinances, codes, and orders of any and all governmental bodies, agencies, authorities, and courts having jurisdiction.

26. *Liens*--Charges, security interests, or encumbrances upon Project funds, real property, or personal property.

27. *Milestone*--A principal event specified in the Contract Documents relating to an intermediate completion date or time prior to Substantial Completion of all the Work.

28. *Notice of Award*--The written notice by OWNER to the apparent successful bidder stating that upon timely compliance by the apparent successful bidder with the conditions precedent listed therein, OWNER will sign and deliver the Agreement.

29. *Notice to Proceed*--A written notice given by OWNER to CONTRACTOR fixing the date on which the Contract Times will commence to run and on which CONTRACTOR shall start to perform the Work under the Contract Documents.

30. *OWNER*--The individual, entity, public body, or authority with whom CONTRACTOR has entered into the Agreement and for whom the Work is to be performed.

31. *Partial Utilization*--Use by OWNER of a substantially completed part of the Work for the purpose for which it is intended (or a related purpose) prior to Substantial Completion of all the Work.

32. *PCBs*--Polychlorinated biphenyls.

33. *Petroleum*--Petroleum, including crude oil or any fraction thereof which is liquid at standard conditions of temperature and pressure (60 degrees Fahrenheit and 14.7 pounds per square inch absolute), such as oil, petroleum, fuel oil, oil sludge, oil refuse, gasoline, kerosene, and oil mixed with other non-Hazardous Waste and crude oils.

34. *Project*--The total construction of which the Work to be performed under the Contract Documents may be the whole, or a part as may be indicated elsewhere in the Contract Documents.

35. *Project Manual*--The bound documentary information prepared for bidding and constructing the Work. A listing of the contents of the Project Manual, which may be bound in one or more volumes, is contained in the table(s) of contents.

36. *Radioactive Material*--Source, special nuclear, or byproduct material as defined by the Atomic Energy Act of 1954 (42 USC Section 2011 et seq.) as amended from time to time.

37. *Resident Project Representative*--The authorized representative of ENGINEER who may be assigned to the Site or any part thereof.

38. *Samples*--Physical examples of materials, equipment, or workmanship that are representative of some portion of the Work and which establish the standards by which such portion of the Work will be judged.

39. *Shop Drawings*--All drawings, diagrams, illustrations, schedules, and other data or information which are specifically prepared or assembled by or for CONTRACTOR and submitted by CONTRACTOR to illustrate some portion of the Work.

40. *Site*--Lands or areas indicated in the Contract Documents as being furnished by OWNER upon which the Work is to be performed, including rights-of-way and easements for access thereto, and such other lands furnished by OWNER which are designated for the use of CONTRACTOR.

41. *Specifications*--That part of the Contract Documents consisting of written technical descriptions of materials, equipment, systems, standards, and workmanship as applied to the Work and certain administrative details applicable thereto.

42. *Subcontractor*--An individual or entity having a direct contract with CONTRACTOR or with any other Subcontractor for the performance of a part of the Work at the Site.

43. *Substantial Completion*--The time at which the Work (or a specified part thereof) has progressed to the point where, in the opinion of ENGINEER, the Work (or a specified part thereof) is sufficiently complete, in accordance with the Contract Documents, so that the Work (or a specified part thereof) can be utilized for the purposes for which it is intended. The terms "substantially complete" and "substantially completed" as applied to all or part of the Work refer to Substantial Completion thereof.

44. *Supplementary Conditions*--That part of the Contract Documents which amends or supplements these General Conditions.

45. *Supplier*--A manufacturer, fabricator, supplier, distributor, materialman, or vendor having a direct contract with CONTRACTOR or with any Subcontractor to furnish materials or equipment to be incorporated in the Work by CONTRACTOR or any Subcontractor.

46. *Underground Facilities*--All underground pipelines, conduits, ducts, cables, wires, manholes, vaults, tanks, tunnels, or other such facilities or attachments, and any encasements containing such facilities, including those that convey electricity, gases, steam, liquid petroleum products, telephone or other communications, cable television, water, wastewater, storm water, other liquids or chemicals, or traffic or other control systems.

47. *Unit Price Work*--Work to be paid for on the basis of unit prices.

48. *Work*--The entire completed construction or the various separately identifiable parts thereof required to be provided under the Contract Documents. Work includes and is the result of performing or providing all labor, services, and documentation necessary to produce such construction, and furnishing, installing, and incorporating all materials and equipment into such construction, all as required by the Contract Documents.

49. *Work Change Directive*--A written statement to CONTRACTOR issued on or after the Effective Date of the Agreement and signed by OWNER and recommended by ENGINEER ordering an addition, deletion, or revision in the Work, or responding to differing or unforeseen subsurface or physical conditions under which the Work is to be performed or to emergencies. A Work Change Directive will not change the Contract Price or the Contract Times but is evidence that the parties expect that the change ordered or documented by a Work Change Directive will be incorporated in a subsequently issued Change Order following negotiations by the parties as to its effect, if any, on the Contract Price or Contract Times.

50. *Written Amendment*--A written statement modifying the Contract Documents, signed by OWNER and CONTRACTOR on or after the Effective Date of the Agreement and normally dealing with the nonengineering or nontechnical rather than strictly construction-related aspects of the Contract Documents.

1.02 *Terminology*

A. *Intent of Certain Terms or Adjectives*

1. Whenever in the Contract Documents the terms “as allowed,” “as approved,” or terms of like effect or import are used, or the adjectives “reasonable,” “suitable,” “acceptable,” “proper,” “satisfactory,” or adjectives of like effect or import are used to describe an action or determination of ENGINEER as to the Work, it is intended that such action or determination will be solely to evaluate, in general, the completed Work for compliance with the requirements of and information in the Contract Documents and conformance with the design concept of the completed Project as a functioning whole as shown or indicated in the Contract Documents (unless there is a specific statement indicating otherwise). The use of any such term or adjective shall not be effective to assign to ENGINEER any duty or authority to supervise or direct the performance of the Work or any duty or authority to undertake responsibility contrary to the provisions of paragraph 9.10 or any other provision of the Contract Documents.

B. *Day*

1. The word “day” shall constitute a calendar day of 24 hours measured from midnight to the next midnight.

C. *Defective*

1. The word “defective,” when modifying the word “Work,” refers to Work that is unsatisfactory, faulty, or deficient in that it does not conform to the Contract Documents or does not meet the requirements of any inspection, reference standard, test, or approval referred to in the Contract Documents, or has been damaged prior to ENGINEER’s recommendation of final payment (unless responsibility for the protection thereof has been assumed by OWNER at Substantial Completion in accordance with paragraph 14.04 or 14.05).

D. *Furnish, Install, Perform, Provide*

1. The word “furnish,” when used in connection with services, materials, or equipment, shall mean to supply and deliver said services, materials, or equipment to the Site (or some other

specified location) ready for use or installation and in usable or operable condition.

2. The word “install,” when used in connection with services, materials, or equipment, shall mean to put into use or place in final position said services, materials, or equipment complete and ready for intended use.

3. The words “perform” or “provide,” when used in connection with services, materials, or equipment, shall mean to furnish and install said services, materials, or equipment complete and ready for intended use.

4. When “furnish,” “install,” “perform,” or “provide” is not used in connection with services, materials, or equipment in a context clearly requiring an obligation of CONTRACTOR, “provide” is implied.

E. Unless stated otherwise in the Contract Documents, words or phrases which have a well-known technical or construction industry or trade meaning are used in the Contract Documents in accordance with such recognized meaning.

ARTICLE 2 - PRELIMINARY MATTERS

2.01 *Delivery of Bonds*

A. When CONTRACTOR delivers the executed Agreements to OWNER, CONTRACTOR shall also deliver to OWNER such Bonds as CONTRACTOR may be required to furnish.

2.02* *Copies of Documents*

A. OWNER shall furnish to CONTRACTOR up to ten copies of the Contract Documents. Additional copies will be furnished upon request at the cost of reproduction.

2.03 *Commencement of Contract Times; Notice to Proceed*

A. The Contract Times will commence to run on the thirtieth day after the Effective Date of the Agreement or, if a Notice to Proceed is given, on the day indicated in the Notice to Proceed. A Notice to Proceed may be given at any time within 30 days after the Effective Date of the Agreement. In no event will the Contract Times com-

mence to run later than the sixtieth day after the day of Bid opening or the thirtieth day after the Effective Date of the Agreement, whichever date is earlier.

2.04 *Starting the Work*

A. CONTRACTOR shall start to perform the Work on the date when the Contract Times commence to run. No Work shall be done at the Site prior to the date on which the Contract Times commence to run.

*See Supplementary Conditions

2.05* *Before Starting Construction*

A. *CONTRACTOR's Review of Contract Documents:* Before undertaking each part of the Work, CONTRACTOR shall carefully study and compare the Contract Documents and check and verify pertinent figures therein and all applicable field measurements. CONTRACTOR shall promptly report in writing to ENGINEER any conflict, error, ambiguity, or discrepancy which CONTRACTOR may discover and shall obtain a written interpretation or clarification from ENGINEER before proceeding with any Work affected thereby; however, CONTRACTOR shall not be liable to OWNER or ENGINEER for failure to report any conflict, error, ambiguity, or discrepancy in the Contract Documents unless CONTRACTOR knew or reasonably should have known thereof.

B. *Preliminary Schedules:* Within ten days after the Effective Date of the Agreement (unless otherwise specified in the General Requirements), CONTRACTOR shall submit to ENGINEER for its timely review:

1. a preliminary progress schedule indicating the times (numbers of days or dates) for starting and completing the various stages of the Work, including any Milestones specified in the Contract Documents;
2. a preliminary schedule of Shop Drawing and Sample submittals which will list each required submittal and the times for submitting, reviewing, and processing such submittal; and
3. a preliminary schedule of values for all of the Work which includes quantities and prices of items which when added together equal the Contract Price and subdivides the Work into

component parts in sufficient detail to serve as the basis for progress payments during performance of the Work. Such prices will include an appropriate amount of overhead and profit applicable to each item of Work.

* C. *Evidence of Insurance:* Before any Work at the Site is started, CONTRACTOR and OWNER shall each deliver to the other, with copies to each additional insured identified in the Supplementary Conditions, certificates of insurance (and other evidence of insurance which either of them or any additional insured may reasonably request) which CONTRACTOR and OWNER respectively are required to purchase and maintain in accordance with Article 5.

2.06 *Preconstruction Conference*

A. Within 20 days after the Contract Times start to run, but before any Work at the Site is started, a conference attended by CONTRACTOR, ENGINEER, and others as appropriate will be held to establish a working understanding among the parties as to the Work and to discuss the schedules referred to in paragraph 2.05.B, procedures for handling Shop Drawings and other submittals, processing Applications for Payment, and maintaining required records.

2.07 *Initial Acceptance of Schedules*

A. Unless otherwise provided in the Contract Documents, at least ten days before submission of the first Application for Payment a conference attended by CONTRACTOR, ENGINEER, and others as appropriate will be held to review for acceptability to ENGINEER as provided below the schedules submitted in accordance with paragraph 2.05.B. CONTRACTOR shall have an additional ten days to make corrections and adjustments and to complete and resubmit the schedules. No progress payment shall be made to CONTRACTOR until acceptable schedules are submitted to ENGINEER.

1. The progress schedule will be acceptable to ENGINEER if it provides an orderly progression of the Work to completion within any specified Milestones and the Contract Times. Such acceptance will not impose on ENGINEER responsibility for the progress schedule, for sequencing, scheduling, or progress of the Work nor interfere with or relieve CONTRACTOR from CONTRACTOR's full responsibility therefor.

2. CONTRACTOR's schedule of Shop Drawing and Sample submittals will be acceptable to ENGINEER if it provides a workable arrangement for reviewing and processing the required submittals.

3. CONTRACTOR's schedule of values will be acceptable to ENGINEER as to form and substance if it provides a reasonable allocation of the Contract Price to component parts of the Work.

*See Supplementary Conditions

ARTICLE 3 - CONTRACT DOCUMENTS: INTENT, AMENDING, REUSE

3.01* *Intent*

A. The Contract Documents are complementary; what is called for by one is as binding as if called for by all.

B. It is the intent of the Contract Documents to describe a functionally complete Project (or part thereof) to be constructed in accordance with the Contract Documents. Any labor, documentation, services, materials, or equipment that may reasonably be inferred from the Contract Documents or from prevailing custom or trade usage as being required to produce the intended result will be provided whether or not specifically called for at no additional cost to OWNER.

C. Clarifications and interpretations of the Contract Documents shall be issued by ENGINEER as provided in Article 9.

3.02 *Reference Standards*

A. *Standards, Specifications, Codes, Laws, and Regulations*

1. Reference to standards, specifications, manuals, or codes of any technical society, organization, or association, or to Laws or Regulations, whether such reference be specific or by implication, shall mean the standard, specification, manual, code, or Laws or Regulations in effect at the time of opening of Bids (or on the Effective Date of the Agreement if there were no Bids), except as may be otherwise specifically stated in the Contract Documents.

2. No provision of any such standard, specification, manual or code, or any instruction of a Supplier shall be effective to change the duties or responsibilities of OWNER, CONTRACTOR, or ENGINEER, or any of their subcontractors, consultants, agents, or employees from those set forth in the Contract Documents, nor shall any such provision or instruction be effective to assign to OWNER, ENGINEER, or any of ENGINEER's Consultants, agents, or employees any duty or authority to supervise or direct the performance of the Work or any duty or authority to undertake responsibility inconsistent with the provisions of the Contract Documents.

3.03 *Reporting and Resolving Discrepancies*

A. *Reporting Discrepancies*

1. If, during the performance of the Work, CONTRACTOR discovers any conflict, error, ambiguity, or discrepancy within the Contract Documents or between the Contract Documents and any provision of any Law or Regulation applicable to the performance of the Work or of any standard, specification, manual or code, or of any instruction of any Supplier, CONTRACTOR shall report it to ENGINEER in writing at once. CONTRACTOR shall not proceed with the Work affected thereby (except in an emergency as required by paragraph 6.16.A) until an amendment or supplement to the Contract Documents has been issued by one of the methods indicated in paragraph 3.04; provided, however, that CONTRACTOR shall not be liable to OWNER or ENGINEER for failure to report any such conflict, error, ambiguity, or discrepancy unless CONTRACTOR knew or reasonably should have known thereof.

B. *Resolving Discrepancies*

1. Except as may be otherwise specifically stated in the Contract Documents, the provisions of the Contract Documents shall take precedence in resolving any conflict, error, ambiguity, or discrepancy between the provisions of the Contract Documents and:

a. the provisions of any standard, specification, manual, code, or instruction (whether or not specifically incorporated by reference in the Contract Documents); or

b. the provisions of any Laws or Regulations applicable to the performance of the Work (unless such an interpretation of the provisions of the Contract Documents would result in violation of such Law or Regulation).

3.04 *Amending and Supplementing Contract Documents*

A. The Contract Documents may be amended to provide for additions, deletions, and revisions in the Work or to modify the terms and conditions thereof in one or

*See Supplementary Conditions

B. The requirements of the Contract Documents may be supplemented, and minor variations and deviations in the Work may be authorized, by one or more of the following ways: (i) a Field Order; (ii) ENGINEER's approval of a Shop Drawing or Sample; or (iii) ENGINEER's written interpretation or clarification.

3.05 *Reuse of Documents*

A. CONTRACTOR and any Subcontractor or Supplier or other individual or entity performing or furnishing any of the Work under a direct or indirect contract with OWNER: (i) shall not have or acquire any title to or ownership rights in any of the Drawings, Specifications, or other documents (or copies of any thereof) prepared by or bearing the seal of ENGINEER or ENGINEER's Consultant, including electronic media editions; and (ii) shall not reuse any of such Drawings, Specifications, other documents, or copies thereof on extensions of the Project or any other project without written consent of OWNER and ENGINEER and specific written verification or adaption by ENGINEER. This prohibition will survive final payment, completion, and acceptance of the Work, or termination or completion of the Contract. Nothing herein shall preclude CONTRACTOR from retaining copies of the Contract Documents for record purposes.

ARTICLE 4 - AVAILABILITY OF LANDS; SUBSURFACE AND PHYSICAL CONDITIONS; REFERENCE POINTS

4.01 *Availability of Lands*

A. OWNER shall furnish the Site. OWNER shall notify CONTRACTOR of any encumbrances or

restrictions not of general application but specifically related to use of the Site with which CONTRACTOR must comply in performing the Work. OWNER will obtain in a timely manner and pay for easements for permanent structures or permanent changes in existing facilities. If CONTRACTOR and OWNER are unable to agree on entitlement to or on the amount or extent, if any, of any adjustment in the Contract Price or Contract Times, or both, as a result of any delay in OWNER's furnishing the Site, CONTRACTOR may make a Claim therefor as provided in paragraph 10.05.

B. Upon reasonable written request, OWNER shall furnish CONTRACTOR with a current statement of record legal title and legal description of the lands upon which the Work is to be performed and OWNER's interest therein as necessary for giving notice of or filing a mechanic's or construction lien against such lands in accordance with applicable Laws and Regulations.

C. CONTRACTOR shall provide for all additional lands and access thereto that may be required for temporary construction facilities or storage of materials and equipment.

4.02* *Subsurface and Physical Conditions*

A.* *Reports and Drawings:* The Supplementary Conditions identify:

1. those reports of explorations and tests of subsurface conditions at or contiguous to the Site that ENGINEER has used in preparing the Contract Documents; and

2. those drawings of physical conditions in or relating to existing surface or subsurface structures at or contiguous to the Site (except Underground Facilities) that ENGINEER has used in preparing the Contract Documents.

B. *Limited Reliance by CONTRACTOR on Technical Data Authorized:* CONTRACTOR may rely upon the general accuracy of the "technical data" contained in such reports and drawings, but such reports and drawings are not Contract Documents. Such "technical data" is identified in the Supplementary Conditions. Except for such reliance on such "technical data," CONTRACTOR may not rely upon or make any Claim against OWNER, ENGINEER, or any of ENGINEER's Consultants with respect to:

1. the completeness of such reports and drawings for CONTRACTOR's purposes, includ-

ing, but not limited to, any aspects of the means, methods, techniques, sequences, and procedures of construction to be employed by CONTRACTOR, and safety precautions and programs incident thereto; or

2. other data, interpretations, opinions, and information contained in such reports or shown or indicated in such drawings; or

3. any CONTRACTOR interpretation of or conclusion drawn from any "technical data" or any such other data, interpretations, opinions, or information.

*See Supplementary Conditions

4.03 *Differing Subsurface or Physical Conditions*

A. *Notice:* If CONTRACTOR believes that any subsurface or physical condition at or contiguous to the Site that is uncovered or revealed either:

1. is of such a nature as to establish that any "technical data" on which CONTRACTOR is entitled to rely as provided in paragraph 4.02 is materially inaccurate; or

2. is of such a nature as to require a change in the Contract Documents; or

3. differs materially from that shown or indicated in the Contract Documents; or

4. is of an unusual nature, and differs materially from conditions ordinarily encountered and generally recognized as inherent in work of the character provided for in the Contract Documents; then CONTRACTOR shall, promptly after becoming aware thereof and before further disturbing the subsurface or physical conditions or performing any Work in connection therewith (except in an emergency as required by paragraph 6.16.A), notify OWNER and ENGINEER in writing about such condition. CONTRACTOR shall not further disturb such condition or perform any Work in connection therewith (except as aforesaid) until receipt of written order to do so.

B. *ENGINEER's Review:* After receipt of written notice as required by paragraph 4.03.A, ENGINEER will promptly review the pertinent condition, determine the

necessity of OWNER's obtaining additional exploration or tests with respect thereto, and advise OWNER in writing (with a copy to CONTRACTOR) of ENGINEER's findings and conclusions.

C. *Possible Price and Times Adjustments*

1. The Contract Price or the Contract Times, or both, will be equitably adjusted to the extent that the existence of such differing subsurface or physical condition causes an increase or decrease in CONTRACTOR's cost of, or time required for, performance of the Work; subject, however, to the following:

a. such condition must meet any one or more of the categories described in paragraph 4.03.A; and

b. with respect to Work that is paid for on a Unit Price Basis, any adjustment in Contract Price will be subject to the provisions of paragraphs 9.08 and 11.03.

2. CONTRACTOR shall not be entitled to any adjustment in the Contract Price or Contract Times if:

a. CONTRACTOR knew of the existence of such conditions at the time CONTRACTOR made a final commitment to OWNER in respect of Contract Price and Contract Times by the submission of a Bid or becoming bound under a negotiated contract; or

b. the existence of such condition could reasonably have been discovered or revealed as a result of any examination, investigation, exploration, test, or study of the Site and contiguous areas required by the Bidding Requirements or Contract Documents to be conducted by or for CONTRACTOR prior to CONTRACTOR's making such final commitment; or

c. CONTRACTOR failed to give the written notice within the time and as required by paragraph 4.03.A.

3. If OWNER and CONTRACTOR are unable to agree on entitlement to or on the amount or extent, if any, of any adjustment in the Contract Price or Contract Times, or both, a Claim may be

made therefor as provided in paragraph 10.05. However, OWNER, ENGINEER, and ENGINEER's Consultants shall not be liable to CONTRACTOR for any claims, costs, losses, or damages (including but not limited to all fees and charges of engineers, architects, attorneys, and other professionals and all court or arbitration or other dispute resolution costs) sustained by CONTRACTOR on or in connection with any other project or anticipated project.

4.04 *Underground Facilities*

A. *Shown or Indicated:* The information and data shown or indicated in the Contract Documents with respect to existing Underground Facilities at or contiguous to the Site is based on information and data furnished to OWNER or ENGINEER by the owners of such Underground Facilities, including OWNER, or by others. Unless it is otherwise expressly provided in the Supplementary Conditions:

1. OWNER and ENGINEER shall not be responsible for the accuracy or completeness of any such information or data; and

2. the cost of all of the following will be included in the Contract Price, and CONTRACTOR shall have full responsibility for:

a. reviewing and checking all such information and data,

b. locating all Underground Facilities shown or indicated in the Contract Documents,

c. coordination of the Work with the owners of such Underground Facilities, including OWNER, during construction, and

d. the safety and protection of all such Underground Facilities and repairing any damage thereto resulting from the Work.

B. *Not Shown or Indicated*

1. If an Underground Facility is uncovered or revealed at or contiguous to the Site which was not shown or indicated, or not shown or indicated with reasonable accuracy in the Contract Documents, CONTRACTOR shall, promptly after becoming aware thereof and before further disturbing conditions affected thereby or

performing any Work in connection therewith (except in an emergency as required by paragraph 6.16.A), identify the owner of such Underground Facility and give written notice to that owner and to OWNER and ENGINEER. ENGINEER will promptly review the Underground Facility and determine the extent, if any, to which a change is required in the Contract Documents to reflect and document the consequences of the existence or location of the Underground Facility. During such time, CONTRACTOR shall be responsible for the safety and protection of such Underground Facility.

2. If ENGINEER concludes that a change in the Contract Documents is required, a Work Change Directive or a Change Order will be issued to reflect and document such consequences. An equitable adjustment shall be made in the Contract Price of Contract Times, or both, to the extent that they are attributable to the existence or location of any Underground Facility that was not shown or indicated or not shown or indicated with reasonable accuracy in the Contract Documents and that CONTRACTOR did not know of and could not reasonably have been expected to be aware of or to have anticipated. If OWNER and CONTRACTOR are unable to agree on entitlement to or on the amount or extent, if any, of any such adjustment in Contract Price or Contract Times, OWNER or CONTRACTOR may make a Claim therefor as provided in paragraph 10.05.

4.05* *Reference Points*

A. OWNER shall provide engineering surveys to establish reference points for construction which in ENGINEER's judgment are necessary to enable CONTRACTOR to proceed with the Work. CONTRACTOR shall be responsible for laying out the Work, shall protect and preserve the established reference points and property monuments, and shall make no changes or relocations without the prior written approval of OWNER.

CONTRACTOR shall report to ENGINEER whenever any reference point or property monument is lost or destroyed or requires relocation because of necessary changes in grades or locations, and shall be responsible for the accurate replacement or relocation of such reference points or property monuments by professionally qualified personnel.

4.06 *Hazardous Environmental Condition at Site*

A. *Reports and Drawings*: Reference is made to the Supplementary Conditions for the identification of those reports and drawings relating to a Hazardous Environmental Condition identified at the Site, if any, that have been utilized by the ENGINEER in the preparation of the Contract Documents.

B. *Limited Reliance by CONTRACTOR on Technical Data Authorized*: CONTRACTOR may rely upon the general accuracy of the "technical data" contained in such reports and drawings, but such reports and drawings are not Contract Documents. Such "technical data" is identified in the Supplementary Conditions. Except for such reliance on such "technical data," CONTRACTOR may not rely upon or make any Claim against OWNER, ENGINEER or any of ENGINEER's Consultants with respect to:

1. the completeness of such reports and drawings for CONTRACTOR's purposes, including, but not limited to, any aspects of the means, methods, techniques, sequences and procedures of construction to be employed by CONTRACTOR and safety precautions and programs incident thereto; or

*See Supplementary Conditions

2. other data, interpretations, opinions and information contained in such reports or shown or indicated in such drawings; or

3. any CONTRACTOR interpretation of or conclusion drawn from any "technical data" or any such other data, interpretations, opinions or information.

C. CONTRACTOR shall not be responsible for any Hazardous Environmental Condition uncovered or revealed at the Site which was not shown or indicated in Drawings or Specifications or identified in the Contract Documents to be within the scope of the Work. CONTRACTOR shall be responsible for a Hazardous Environmental Condition created with any materials brought to the Site by CONTRACTOR, Subcontractors, Suppliers, or anyone else for whom CONTRACTOR is responsible.

D. If CONTRACTOR encounters a Hazardous Environmental Condition or if CONTRACTOR or anyone for whom CONTRACTOR is responsible creates a Hazardous Environmental Condition, CONTRACTOR shall immediately: (i) secure or otherwise isolate such condition;

(ii) stop all Work in connection with such condition and in any area affected thereby (except in an emergency as required by paragraph 6.16); and (iii) notify OWNER and ENGINEER (and promptly thereafter confirm such notice in writing). OWNER shall promptly consult with ENGINEER concerning the necessity for OWNER to retain a qualified expert to evaluate such condition or take corrective action, if any.

E. CONTRACTOR shall not be required to resume Work in connection with such condition or in any affected area until after OWNER has obtained any required permits related thereto and delivered to CONTRACTOR written notice: (i) specifying that such condition and any affected area is or has been rendered safe for the resumption of Work; or (ii) specifying any special conditions under which such Work may be resumed safely. If OWNER and CONTRACTOR cannot agree as to entitlement to or on the amount or extent, if any, of any adjustment in Contract Price or Contract Times, or both, as a result of such Work stoppage or such special conditions under which Work is agreed to be resumed by CONTRACTOR, either party may make a Claim therefor as provided in paragraph 10.05.

F. If after receipt of such written notice CONTRACTOR does not agree to resume such Work based on a reasonable belief it is unsafe, or does not agree to resume such Work under such special conditions, then OWNER may order the portion of the Work that is in the area affected by such condition to be deleted from the Work. If OWNER and CONTRACTOR cannot agree as to entitlement to or on the amount or extent, if any, of an adjustment in Contract Price or Contract Times as a result of deleting such portion of the Work, then either party may make a Claim therefor as provided in paragraph 10.05.

OWNER may have such deleted portion of the Work performed by OWNER's own forces or others in accordance with Article 7.

G. To the fullest extent permitted by Laws and Regulations, OWNER shall indemnify and hold harmless CONTRACTOR, Subcontractors, ENGINEER, ENGINEER's Consultants and the officers, directors, partners, employees, agents, other consultants, and subcontractors of each and any of them from and against all claims, costs, losses, and damages (including but not limited to all fees and charges of engineers, architects, attorneys, and other professionals and all court or arbitration or other dispute resolution costs) arising out of or relating to a Hazardous Environmental Condition, provided that such Hazardous Environmental Condition: (i) was not shown or indicated in the Drawings or

Specifications or identified in the Contract Documents to be included within the scope of the Work, and (ii) was not created by CONTRACTOR or by anyone for whom CONTRACTOR is responsible. Nothing in this paragraph 4.06.E shall obligate OWNER to indemnify any individual or entity from and against the consequences of that individual's or entity's own negligence.

H. To the fullest extent permitted by Laws and Regulations, CONTRACTOR shall indemnify and hold harmless OWNER, ENGINEER, ENGINEER's Consultants, and the officers, directors, partners, employees, agents, other consultants, and subcontractors of each and any of them from and against all claims, costs, losses, and damages (including but not limited to all fees and charges of engineers, architects, attorneys, and other professionals and all court or arbitration or other dispute resolution costs) arising out of or relating to a Hazardous Environmental Condition created by CONTRACTOR or by anyone for whom CONTRACTOR is responsible. Nothing in this paragraph 4.06.F shall obligate CONTRACTOR to indemnify any individual or entity from and against the consequences of that individual's or entity's own negligence.

I. The provisions of paragraphs 4.02, 4.03, and 4.04 are not intended to apply to a Hazardous Environmental Condition uncovered or revealed at the Site.

*See Supplementary Conditions

ARTICLE 5 - BONDS AND INSURANCE

5.01* *Performance, Payment, and Other Bonds*

A. CONTRACTOR shall furnish performance and payment Bonds, each in an amount at least equal to the Contract Price as security for the faithful performance and payment of all CONTRACTOR's obligations under the Contract Documents. These Bonds shall remain in effect at least until one year after the date when final payment becomes due, except as provided otherwise by Laws or Regulations or by the Contract Documents. CONTRACTOR shall also furnish such other Bonds as are required by the Contract Documents.

B.* All Bonds shall be in the form prescribed by the Contract Documents except as provided otherwise by Laws or Regulations, and shall be executed by such sureties as are named in the current list of "Companies Holding Certificates of Authority as Acceptable Sureties on Federal Bonds and as Acceptable Reinsuring Compa-

nies" as published in Circular 570 (amended) by the Financial Management Service, Surety Bond Branch, U.S. Department of the Treasury. All Bonds signed by an agent must be accompanied by a certified copy of such agent's authority to act.

C. If the surety on any Bond furnished by CONTRACTOR is declared bankrupt or becomes insolvent or its right to do business is terminated in any state where any part of the Project is located or it ceases to meet the requirements of paragraph 5.01.B, CONTRACTOR shall within 20 days thereafter substitute another Bond and surety, both of which shall comply with the requirements of paragraphs 5.01.B and 5.02.

5.02 *Licensed Sureties and Insurers*

A. All Bonds and insurance required by the Contract Documents to be purchased and maintained by OWNER or CONTRACTOR shall be obtained from surety or insurance companies that are duly licensed or authorized in the jurisdiction in which the Project is located to issue Bonds or insurance policies for the limits and coverages so required. Such surety and insurance companies shall also meet such additional requirements and qualifications as may be provided in the Supplementary Conditions.

5.03 *Certificates of Insurance*

A. CONTRACTOR shall deliver to OWNER, with copies to each additional insured identified in the Supplementary Conditions, certificates of insurance (and other evidence of insurance requested by OWNER or any other additional insured) which CONTRACTOR is required to purchase and maintain. OWNER shall deliver to CONTRACTOR, with copies to each additional insured identified in the Supplementary Conditions, certificates of insurance (and other evidence of insurance requested by CONTRACTOR or any other additional insured) which OWNER is required to purchase and maintain.

5.04* *CONTRACTOR's Liability Insurance*

A. CONTRACTOR shall purchase and maintain such liability and other insurance as is appropriate for the Work being performed and as will provide protection from claims set forth below which may arise out of or result from CONTRACTOR's performance of the Work and CONTRACTOR's other obligations under the Contract Documents, whether it is to be performed by CONTRACTOR, any Subcontractor or Supplier, or by anyone directly or indirectly employed by any of them to

perform any of the Work, or by anyone for whose acts any of them may be liable:

1. claims under workers' compensation, disability benefits, and other similar employee benefit acts;
2. claims for damages because of bodily injury, occupational sickness or disease, or death of CONTRACTOR's employees;
3. claims for damages because of bodily injury, sickness or disease, or death of any person other than CONTRACTOR's employees;
4. claims for damages insured by reasonably available personal injury liability coverage which are sustained: (i) by any person as a result of an offense directly or indirectly related to the employment of such person by CONTRACTOR, or (ii) by any other person for any other reason;
5. claims for damages, other than to the Work itself, because of injury to or destruction of tangible property wherever located, including loss of use resulting therefrom; and
6. claims for damages because of bodily injury or death of any person or property damage arising out of the ownership, maintenance or use of any motor vehicle.

B. The policies of insurance so required by this paragraph 5.04 to be purchased and maintained shall:

*See Supplementary Conditions

1. with respect to insurance required by paragraphs 5.04.A.3 through 5.04.A.6 inclusive, include as additional insureds (subject to any customary exclusion in respect of professional liability) OWNER, ENGINEER, ENGINEER's Consultants, and any other individuals or entities identified in the Supplementary Conditions, all of whom shall be listed as additional insureds, and include coverage for the respective officers, directors, partners, employees, agents, and other consultants and subcontractors of each and any of all such additional insureds, and the insurance afforded to these additional insureds shall provide primary coverage for all claims covered thereby;

2. include at least the specific coverages and be written for not less than the limits of liability provided in the Supplementary Conditions or required by Laws or Regulations, whichever is greater;

3. include completed operations insurance;

4. include contractual liability insurance covering CONTRACTOR's indemnity obligations under paragraphs 6.07, 6.11, and 6.20;

5. contain a provision or endorsement that the coverage afforded will not be canceled, materially changed or renewal refused until at least thirty days prior written notice has been given to OWNER and CONTRACTOR and to each other additional insured identified in the Supplementary Conditions to whom a certificate of insurance has been issued (and the certificates of insurance furnished by the CONTRACTOR pursuant to paragraph 5.03 will so provide);

6. remain in effect at least until final payment and at all times thereafter when CONTRACTOR may be correcting, removing, or replacing defective Work in accordance with paragraph 13.07; and

7. with respect to completed operations insurance, and any insurance coverage written on a claims-made basis, remain in effect for at least two years after final payment (and CONTRACTOR shall furnish OWNER and each other additional insured identified in the Supplementary Conditions, to whom a certificate of insurance has been issued, evidence satisfactory to OWNER and any such additional insured of continuation of such insurance at final payment and one year thereafter).

5.05 *OWNER's Liability Insurance*

A.* In addition to the insurance required to be provided by CONTRACTOR under paragraph 5.04, OWNER, at OWNER's option, may purchase and maintain at OWNER's expense OWNER's own liability insurance as will protect OWNER against claims which may arise from operations under the Contract Documents.

5.06* *Property Insurance*

A. Unless otherwise provided in the Supplementary Conditions, OWNER shall purchase and maintain property

insurance upon the Work at the Site in the amount of the full replacement cost thereof (subject to such deductible amounts as may be provided in the Supplementary Conditions or required by Laws and Regulations). This insurance shall:

1. include the interests of OWNER, CONTRACTOR, Subcontractors, ENGINEER, ENGINEER's Consultants, and any other individuals or entities identified in the Supplementary Conditions, and the officers, directors, partners, employees, agents, and other consultants and subcontractors of each and any of them, each of whom is deemed to have an insurable interest and shall be listed as an additional insured;

2. be written on a Builder's Risk "all-risk" or open peril or special causes of loss policy form that shall at least include insurance for physical loss or damage to the Work, temporary buildings, false work, and materials and equipment in transit, and shall insure against at least the following perils or causes of loss: fire, lightning, extended coverage, theft, vandalism and malicious mischief, earthquake, collapse, debris removal, demolition occasioned by enforcement of Laws and Regulations, water damage, and such other perils or causes of loss as may be specifically required by the Supplementary Conditions;

3. include expenses incurred in the repair or replacement of any insured property (including but not limited to fees and charges of engineers and architects);

*See Supplementary Conditions

4. cover materials and equipment stored at the Site or at another location that was agreed to in writing by OWNER prior to being incorporated in the Work, provided that such materials and equipment have been included in an Application for Payment recommended by ENGINEER;

5. allow for partial utilization of the Work by OWNER;

6. include testing and startup; and

7. be maintained in effect until final payment is made unless otherwise agreed to in writing by OWNER, CONTRACTOR, and ENGINEER with

30 days written notice to each other additional insured to whom a certificate of insurance has been issued.

B.* OWNER shall purchase and maintain such boiler and machinery insurance or additional property insurance as may be required by the Supplementary Conditions or Laws and Regulations which will include the interests of OWNER, CONTRACTOR, Subcontractors, ENGINEER, ENGINEER's Consultants, and any other individuals or entities identified in the Supplementary Conditions, each of whom is deemed to have an insurable interest and shall be listed as an insured or additional insured.

C.* All the policies of insurance (and the certificates or other evidence thereof) required to be purchased and maintained in accordance with paragraph 5.06 will contain a provision or endorsement that the coverage afforded will not be canceled or materially changed or renewal refused until at least 30 days prior written notice has been given to OWNER and CONTRACTOR and to each other additional insured to whom a certificate of insurance has been issued and will contain waiver provisions in accordance with paragraph 5.07.

D.* OWNER shall not be responsible for purchasing and maintaining any property insurance specified in this paragraph 5.06 to protect the interests of CONTRACTOR, Subcontractors, or others in the Work to the extent of any deductible amounts that are identified in the Supplementary Conditions. The risk of loss within such identified deductible amount will be borne by CONTRACTOR, Subcontractors, or others suffering any such loss, and if any of them wishes property insurance coverage within the limits of such amounts, each may purchase and maintain it at the purchaser's own expense.

E.* If CONTRACTOR requests in writing that other special insurance be included in the property insurance policies provided under paragraph 5.06, OWNER shall, if possible, include such insurance, and the cost thereof will be charged to CONTRACTOR by appropriate Change Order or Written Amendment. Prior to commencement of the Work at the Site, OWNER shall in writing advise CONTRACTOR whether or not such other insurance has been procured by OWNER.

5.07 Waiver of Rights

A.* OWNER and CONTRACTOR intend that all policies purchased in accordance with paragraph 5.06 will protect OWNER, CONTRACTOR, Subcontractors, ENGINEER, ENGINEER's Consultants, and all other

individuals or entities identified in the Supplementary Conditions to be listed as insureds or additional insureds (and the officers, directors, partners, employees, agents, and other consultants and subcontractors of each and any of them) in such policies and will provide primary coverage for all losses and damages caused by the perils or causes of loss covered thereby. All such policies shall contain provisions to the effect that in the event of payment of any loss or damage the insurers will have no rights of recovery against any of the insureds or additional insureds thereunder. OWNER and CONTRACTOR waive all rights against each other and their respective officers, directors, partners, employees, agents, and other consultants and subcontractors of each and any of them for all losses and damages caused by, arising out of or resulting from any of the perils or causes of loss covered by such policies and any other property insurance applicable to the Work; and, in addition, waive all such rights against Subcontractors, ENGINEER, ENGINEER's Consultants, and all other individuals or entities identified in the Supplementary Conditions to be listed as insureds or additional insureds (and the officers, directors, partners, employees, agents, and other consultants and subcontractors of each and any of them) under such policies for losses and damages so caused.

None of the above waivers shall extend to the rights that any party making such waiver may have to the proceeds of insurance held by OWNER as trustee or otherwise payable under any policy so issued.

B. OWNER waives all rights against CONTRACTOR, Subcontractors, ENGINEER, ENGINEER's Consultants, and the officers, directors, partners, employees, agents, and other consultants and subcontractors of each and any of them for:

*See Supplementary Conditions

1. loss due to business interruption, loss of use, or other consequential loss extending beyond direct physical loss or damage to OWNER's property or the Work caused by, arising out of, or resulting from fire or other peril whether or not insured by OWNER; and

2. loss or damage to the completed Project or part thereof caused by, arising out of, or resulting from fire or other insured peril or cause of loss covered by any property insurance maintained on the completed Project or part thereof by OWNER during partial utilization pursuant to

paragraph 14.05, after Substantial Completion pursuant to paragraph 14.04, or after final payment pursuant to paragraph 14.07.

C. Any insurance policy maintained by OWNER covering any loss, damage or consequential loss referred to in paragraph 5.07.B shall contain provisions to the effect that in the event of payment of any such loss, damage, or consequential loss, the insurers will have no rights of recovery against CONTRACTOR, Subcontractors, ENGINEER, or ENGINEER's Consultants and the officers, directors, partners, employees, agents, and other consultants and subcontractors of each and any of them.

5.08* *Receipt and Application of Insurance Proceeds*

A.* Any insured loss under the policies of insurance required by paragraph 5.06 will be adjusted with OWNER and made payable to OWNER as fiduciary for the insureds, as their interests may appear, subject to the requirements of any applicable mortgage clause and of paragraph 5.08.B. OWNER shall deposit in a separate account any money so received and shall distribute it in accordance with such agreement as the parties in interest may reach. If no other special agreement is reached, the damaged Work shall be repaired or replaced, the moneys so received applied on account thereof, and the Work and the cost thereof covered by an appropriate Change Order or Written Amendment.

B.* OWNER as fiduciary shall have power to adjust and settle any loss with the insurers unless one of the parties in interest shall object in writing within 15 days after the occurrence of loss to OWNER's exercise of this power. If such objection be made, OWNER as fiduciary shall make settlement with the insurers in accordance with such agreement as the parties in interest may reach. If no such agreement among the parties in interest is reached, OWNER as fiduciary shall adjust and settle the loss with the insurers and, if required in writing by any party in interest, OWNER as fiduciary shall give bond for the proper performance of such duties.

5.09* *Acceptance of Bonds and Insurance; Option to Replace*

A.* If either OWNER or CONTRACTOR has any objection to the coverage afforded by or other provisions of the Bonds or insurance required to be purchased and maintained by the other party in accordance with Article 5 on the basis of non-conformance with the Contract Documents, the objecting party shall so notify the other party in writing within 10 days after receipt of the

certificates (or other evidence requested) required by paragraph 2.05.C. OWNER and CONTRACTOR shall each provide to the other such additional information in respect of insurance provided as the other may reasonably request. If either party does not purchase or maintain all of the Bonds and insurance required of such party by the Contract Documents, such party shall notify the other party in writing of such failure to purchase prior to the start of the Work, or of such failure to maintain prior to any change in the required coverage. Without prejudice to any other right or remedy, the other party may elect to obtain equivalent Bonds or insurance to protect such other party's interests at the expense of the party who was required to provide such coverage, and a Change Order shall be issued to adjust the Contract Price accordingly.

5.10 *Partial Utilization, Acknowledgment of Property Insurer*

A. If OWNER finds it necessary to occupy or use a portion or portions of the Work prior to Substantial Completion of all the Work as provided in paragraph 14.05, no such use or occupancy shall commence before the insurers providing the property insurance pursuant to paragraph 5.06 have acknowledged notice thereof and in writing effected any changes in coverage necessitated thereby. The insurers providing the property insurance shall consent by endorsement on the policy or policies, but the property insurance shall not be canceled or permitted to lapse on account of any such partial use or occupancy.

ARTICLE 6 - CONTRACTOR'S RESPONSIBILITIES

6.01 *Supervision and Superintendence*

A. CONTRACTOR shall supervise, inspect, and direct the Work competently and efficiently, devoting such attention thereto and applying such skills and expertise as may be necessary to perform the Work in accordance with

*See Supplementary Conditions

the Contract Documents. CONTRACTOR shall be solely responsible for the means, methods, techniques, sequences, and procedures of construction, but CONTRACTOR shall not be responsible for the negligence of OWNER or ENGINEER in the design or specification of a specific means, method, technique, sequence, or procedure of

construction which is shown or indicated in and expressly required by the Contract Documents. CONTRACTOR shall be responsible to see that the completed Work complies accurately with the Contract Documents.

B. At all times during the progress of the Work, CONTRACTOR shall assign a competent resident superintendent thereto who shall not be replaced without written notice to OWNER and ENGINEER except under extraordinary circumstances. The superintendent will be CONTRACTOR's representative at the Site and shall have authority to act on behalf of CONTRACTOR. All communications given to or received from the superintendent shall be binding on CONTRACTOR.

6.02 *Labor; Working Hours*

A. CONTRACTOR shall provide competent, suitably qualified personnel to survey, lay out, and construct the

Work as required by the Contract Documents. CONTRACTOR shall at all times maintain good discipline and order at the Site.

B. Except as otherwise required for the safety or protection of persons or the Work or property at the Site or adjacent thereto, and except as otherwise stated in the Contract Documents, all Work at the Site shall be performed during regular working hours, and CONTRACTOR will not permit overtime work or the performance of Work on Saturday, Sunday, or any legal holiday without OWNER's written consent (which will not be unreasonably withheld) given after prior written notice to ENGINEER.

6.03 *Services, Materials, and Equipment*

A. Unless otherwise specified in the General Requirements, CONTRACTOR shall provide and assume full responsibility for all services, materials, equipment, labor, transportation, construction equipment and machinery, tools, appliances, fuel, power, light, heat, telephone, water, sanitary facilities, temporary facilities, and all other facilities and incidentals necessary for the performance, testing, start-up, and completion of the Work.

B. All materials and equipment incorporated into the Work shall be as specified or, if not specified, shall be of good quality and new, except as otherwise provided in the Contract Documents. All warranties and guarantees specifically called for by the Specifications shall expressly

run to the benefit of OWNER. If required by ENGINEER, CONTRACTOR shall furnish satisfactory evidence (including reports of required tests) as to the source, kind, and quality of materials and equipment. All materials and equipment shall be stored, applied, installed, connected, erected, protected, used, cleaned, and conditioned in accordance with instructions of the applicable Supplier, except as otherwise may be provided in the Contract Documents.

6.04 *Progress Schedule*

A. CONTRACTOR shall adhere to the progress schedule established in accordance with paragraph 2.07 as it may be adjusted from time to time as provided below.

1. CONTRACTOR shall submit to ENGINEER for acceptance (to the extent indicated in paragraph 2.07) proposed adjustments in the progress schedule that will not result in changing the Contract Times (or Milestones). Such adjustments will conform generally to the progress schedule then in effect and additionally will comply with any provisions of the General Requirements applicable thereto.

2. Proposed adjustments in the progress schedule that will change the Contract Times (or Milestones) shall be submitted in accordance with the requirements of Article 12. Such adjustments may only be made by a Change Order or Written Amendment in accordance with Article 12.

6.05 *Substitutes and "Or-Equals"*

A. Whenever an item of material or equipment is specified or described in the Contract Documents by using the name of a proprietary item or the name of a particular Supplier, the specification or description is intended to establish the type, function, appearance, and quality required. Unless the specification or description contains or is followed by words reading that no like, equivalent, or "or-equal" item or no substitution is permitted, other items of material or equipment or material or equipment of other Suppliers may be submitted to ENGINEER for review under the circumstances described below.

1. *"Or-Equal" Items:* If in ENGINEER's sole discretion an item of material or equipment proposed by CONTRACTOR is functionally equal to that named and sufficiently similar so that no change in related Work will be required, it may be

considered by ENGINEER as an "or-equal" item, in which case review and approval of the proposed item may, in ENGINEER's sole discretion, be accomplished without compliance with some or all of the requirements for approval of proposed substitute items. For the purposes of this paragraph 6.05.A.1, a proposed item of material or equipment will be considered functionally equal to an item so named if:

a. in the exercise of reasonable judgment ENGINEER determines that: (i) it is at least equal in quality, durability, appearance, strength, and design characteristics; (ii) it will reliably perform at least equally well the function imposed by the design concept of the completed Project as a functioning whole, and;

b. CONTRACTOR certifies that: (i) there is no increase in cost to the OWNER; and (ii) it will conform substantially, even with deviations, to the detailed requirements of the item named in the Contract Documents.

2. *Substitute Items*

a. If in ENGINEER's sole discretion an item of material or equipment proposed by CONTRACTOR does not qualify as an "or-equal" item under paragraph 6.05.A.1, it will be considered a proposed substitute item.

b. CONTRACTOR shall submit sufficient information as provided below to allow ENGINEER to determine that the item of material or equipment proposed is essentially equivalent to that named and an acceptable substitute therefor. Requests for review of proposed substitute items of material or equipment will not be accepted by ENGINEER from anyone other than CONTRACTOR.

c. The procedure for review by ENGINEER will be as set forth in paragraph 6.05.A.2.d, as supplemented in the General Requirements and as ENGINEER may decide is appropriate under the circumstances.

d. CONTRACTOR shall first make written application to ENGINEER for review of a proposed substitute item of material or equipment that CONTRACTOR seeks to furnish or use. The application shall certify

that the proposed substitute item will perform adequately the functions and achieve the results called for by the general design, be similar in substance to that specified, and be suited to the same use as that specified. The application will state the extent, if any, to which the use of the proposed substitute item will prejudice CONTRACTOR's achievement of Substantial Completion on time, whether or not use of the proposed substitute item in the Work will require a change in any of the Contract Documents (or in the provisions of any other direct contract with OWNER for work on the Project) to adapt the design to the proposed substitute item and whether or not incorporation or use of the proposed substitute item in connection with the Work is subject to payment of any license fee or royalty. All variations of the proposed substitute item from that specified will be identified in the application, and available engineering, sales, maintenance, repair, and replacement services will be indicated. The application will also contain an itemized estimate of all costs or credits that will result directly or indirectly from use of such substitute item, including costs of redesign and claims of other contractors affected by any resulting change, all of which will be considered by ENGINEER in evaluating the proposed substitute item. ENGINEER may require CONTRACTOR to furnish additional data about the proposed substitute item.

B. Substitute Construction Methods or Procedures:

If a specific means, method, technique, sequence, or procedure of construction is shown or indicated in and expressly required by the Contract Documents, CONTRACTOR may furnish or utilize a substitute means, method, technique, sequence, or procedure of construction approved by ENGINEER. CONTRACTOR shall submit sufficient information to allow ENGINEER, in ENGINEER's sole discretion, to determine that the substitute proposed is equivalent to that expressly called for by the Contract Documents. The procedure for review by ENGINEER will be similar to that provided in subparagraph 6.05.A.2.

C. Engineer's Evaluation: ENGINEER will be allowed a reasonable time within which to evaluate each proposal or submittal made pursuant to paragraphs 6.05.A and 6.05.B. ENGINEER will be the sole judge of acceptability. No "or-equal" or substitute will be ordered, installed or utilized until ENGINEER's review is complete, which will be evidenced by either a Change Order for a

substitute or an approved Shop Drawing for an "or equal." ENGINEER will advise CONTRACTOR in writing of any negative determination.

D. Special Guarantee: OWNER may require CONTRACTOR to furnish at CONTRACTOR's expense a special performance guarantee or other surety with respect to any substitute.

E. ENGINEER's Cost Reimbursement: ENGINEER will record time required by ENGINEER and ENGINEER's Consultants in evaluating substitute proposed or submitted by CONTRACTOR pursuant to paragraphs 6.05.A.2 and 6.05.B and in making changes in the Contract Documents (or in the provisions of any other direct contract with OWNER for work on the Project) occasioned thereby. Whether or not ENGINEER approves a substitute item so proposed or submitted by CONTRACTOR, CONTRACTOR shall reimburse OWNER for the charges of ENGINEER and ENGINEER's Consultants for evaluating each such proposed substitute.

F. CONTRACTOR's Expense: CONTRACTOR shall provide all data in support of any proposed substitute or "or-equal" at CONTRACTOR's expense.

6.06 *Concerning Subcontractors, Suppliers, and Others*

A. CONTRACTOR shall not employ any Subcontractor, Supplier, or other individual or entity (including those acceptable to OWNER as indicated in paragraph 6.06.B), whether initially or as a replacement, against whom OWNER may have reasonable objection. CONTRACTOR shall not be required to employ any Subcontractor, Supplier, or other individual or entity to furnish or perform any of the Work against whom CONTRACTOR has reasonable objection.

B. If the Supplementary Conditions require the identity of certain Subcontractors, Suppliers, or other individuals or entities to be submitted to OWNER in advance for acceptance by OWNER by a specified date prior to the Effective Date of the Agreement, and if CONTRACTOR has submitted a list thereof in accordance with the Supplementary Conditions, OWNER's acceptance (either in writing or by failing to make written objection thereto by the date indicated for acceptance or objection in the Bidding Documents or the Contract Documents) of any such Subcontractor, Supplier, or other individual or entity so identified may be revoked on the basis of reasonable objection after due investigation. CONTRACTOR shall submit an acceptable replacement

for the rejected Subcontractor, Supplier, or other individual or entity, and the Contract Price will be adjusted by the difference in the cost occasioned by such replacement, and an appropriate Change Order will be issued or Written Amendment signed. No acceptance by OWNER of any such Subcontractor, Supplier, or other individual or entity, whether initially or as a replacement, shall constitute a waiver of any right of OWNER or ENGINEER to reject defective Work.

C. CONTRACTOR shall be fully responsible to OWNER and ENGINEER for all acts and omissions of the Subcontractors, Suppliers, and other individuals or entities performing or furnishing any of the Work just as CONTRACTOR is responsible for CONTRACTOR's own acts and omissions. Nothing in the Contract Documents shall create for the benefit of any such Subcontractor, Supplier, or other individual or entity any contractual relationship between OWNER or ENGINEER and any such Subcontractor, Supplier or other individual or entity, nor shall it create any obligation on the part of OWNER or ENGINEER to pay or to see to the payment of any moneys due any such Subcontractor, Supplier, or other individual or entity except as may otherwise be required by Laws and Regulations.

D. CONTRACTOR shall be solely responsible for scheduling and coordinating the Work of Subcontractors, Suppliers, and other individuals or entities performing or furnishing any of the Work under a direct or indirect contract with CONTRACTOR.

E. CONTRACTOR shall require all Subcontractors, Suppliers, and such other individuals or entities performing or furnishing any of the Work to communicate with ENGINEER through CONTRACTOR.

F. The divisions and sections of the Specifications and the identifications of any Drawings shall not control CONTRACTOR in dividing the Work among Subcontractors or Suppliers or delineating the Work to be performed by any specific trade.

G. All Work performed for CONTRACTOR by a Subcontractor or Supplier will be pursuant to an appropriate agreement between CONTRACTOR and the Subcontractor or Supplier which specifically binds the Subcontractor or Supplier to the applicable terms and conditions of the Contract Documents for the benefit of OWNER and ENGINEER. Whenever any such agreement is with a Subcontractor or Supplier who is listed as an additional insured on the property insurance provided in paragraph 5.06, the agreement between the CONTRAC-

TOR and the Subcontractor or Supplier will contain provisions whereby the Subcontractor or Supplier waives all rights against OWNER, CONTRACTOR, ENGINEER, ENGINEER's Consultants, and all other individuals or entities identified in the Supplementary Conditions to be listed as insureds or additional insureds (and the officers, directors, partners, employees, agents, and other consultants and subcontractors of each and any of them) for all losses and damages caused by, arising out of, relating to, or resulting from any of the perils or causes of loss covered by such policies and any other property insurance applicable to the Work. If the insurers on any such policies require separate waiver forms to be signed by any Subcontractor or Supplier, CONTRACTOR will obtain the same.

6.07 *Patent Fees and Royalties*

A. CONTRACTOR shall pay all license fees and royalties and assume all costs incident to the use in the performance of the Work or the incorporation in the Work of any invention, design, process, product, or device which is the subject of patent rights or copyrights held by others. If a particular invention, design, process, product, or device is specified in the Contract Documents for use in the performance of the Work and if to the actual knowledge of OWNER or ENGINEER its use is subject to patent rights or copyrights calling for the payment of any license fee or royalty to others, the existence of such rights shall be disclosed by OWNER in the Contract Documents. To the fullest extent permitted by Laws and Regulations, CONTRACTOR shall indemnify and hold harmless OWNER, ENGINEER, ENGINEER's Consultants, and the officers, directors, partners, employees or agents, and other consultants of each and any of them from and against all claims, costs, losses, and damages (including but not limited to all fees and charges of engineers, architects, attorneys, and other professionals and all court or arbitration or other dispute resolution costs) arising out of or relating to any infringement of patent rights or copyrights incident to the use in the performance of the Work or resulting from the incorporation in the Work of any invention, design, process, product, or device not specified in the Contract Documents.

6.08 *Permits*

A. Unless otherwise provided in the Supplementary Conditions, CONTRACTOR shall obtain and pay for all construction permits and licenses. OWNER shall assist CONTRACTOR, when necessary, in obtaining such permits and licenses. CONTRACTOR shall pay all governmental charges and inspection fees necessary for

the prosecution of the Work which are applicable at the time of opening of Bids, or, if there are no Bids, on the Effective Date of the Agreement. CONTRACTOR shall pay all charges of utility owners for connections to the Work, and OWNER shall pay all charges of such utility owners for capital costs related thereto, such as plant investment fees.

6.09 *Laws and Regulations*

A. CONTRACTOR shall give all notices and comply with all Laws and Regulations applicable to the performance of the Work. Except where otherwise expressly required by applicable Laws and Regulations, neither OWNER nor ENGINEER shall be responsible for monitoring CONTRACTOR's compliance with any Laws or Regulations.

B. If CONTRACTOR performs any Work knowing or having reason to know that it is contrary to Laws or Regulations, CONTRACTOR shall bear all claims, costs, losses, and damages (including but not limited to all fees and charges of engineers, architects, attorneys, and other professionals and all court or arbitration or other dispute resolution costs) arising out of or relating to such Work; however, it shall not be CONTRACTOR's primary responsibility to make certain that the Specifications and Drawings are in accordance with Laws and Regulations, but this shall not relieve CONTRACTOR of CONTRACTOR's obligations under paragraph 3.03.

C. Changes in Laws or Regulations not known at the time of opening of Bids (or, on the Effective Date of the Agreement if there were no Bids) having an effect on the cost or time of performance of the Work may be the subject of an adjustment in Contract Price or Contract Times. If OWNER and CONTRACTOR are unable to agree on entitlement to or on the amount or extent, if any, of any such adjustment, a Claim may be made therefor as provided in paragraph 10.05.

6.10* *Taxes*

A. CONTRACTOR shall pay all sales, consumer, use, and other similar taxes required to be paid by CONTRACTOR in accordance with the Laws and Regulations of the place of the Project which are applicable during the performance of the Work.

6.11* *Use of Site and Other Areas*

A.* *Limitation on Use of Site and Other Areas*

1. CONTRACTOR shall confine construction equipment, the storage of materials and equipment, and the operations of workers to the Site and other areas permitted by Laws and Regulations,

*See Supplementary Conditions

and shall not unreasonably encumber the Site and other areas with construction equipment or other materials or equipment. CONTRACTOR shall assume full responsibility for any damage to any such land or area, or to the owner or occupant thereof, or of any adjacent land or areas resulting from the performance of the Work.

2. Should any claim be made by any such owner or occupant because of the performance of the Work, CONTRACTOR shall promptly settle with such other party by negotiation or otherwise resolve the claim by arbitration or other dispute resolution proceeding or at law.

3. To the fullest extent permitted by Laws and Regulations, CONTRACTOR shall indemnify and hold harmless OWNER, ENGINEER, ENGINEER's Consultant, and the officers, directors, partners, employees, agents, and other consultants of each and any of them from and against all claims, costs, losses, and damages (including but not limited to all fees and charges of engineers, architects, attorneys, and other professionals and all court or arbitration or other dispute resolution costs) arising out of or relating to any claim or action, legal or equitable, brought by any such owner or occupant against OWNER, ENGINEER, or any other party indemnified hereunder to the extent caused by or based upon CONTRACTOR's performance of the Work.

B. *Removal of Debris During Performance of the Work:* During the progress of the Work CONTRACTOR shall keep the Site and other areas free from accumulations of waste materials, rubbish, and other debris. Removal and disposal of such waste materials, rubbish, and other debris shall conform to applicable Laws and Regulations.

C. *Cleaning*: Prior to Substantial Completion of the Work CONTRACTOR shall clean the Site and make it ready for utilization by OWNER. At the completion of the Work CONTRACTOR shall remove from the Site all tools, appliances, construction equipment and machinery, and surplus materials and shall restore to original condition all property not designated for alteration by the Contract Documents.

D. *Loading Structures*: CONTRACTOR shall not load nor permit any part of any structure to be loaded in any manner that will endanger the structure, nor shall CONTRACTOR subject any part of the Work or adjacent property to stresses or pressures that will endanger it.

6.12 *Record Documents*

A. CONTRACTOR shall maintain in a safe place at the Site one record copy of all Drawings, Specifications, Addenda, Written Amendments, Change Orders, Work Change Directives, Field Orders, and written interpretations and clarifications in good order and annotated to show changes made during construction. These record documents together with all approved Samples and a counterpart of all approved Shop Drawings will be available to ENGINEER for reference. Upon completion of the Work, these record documents, Samples, and Shop Drawings will be delivered to ENGINEER for OWNER.

6.13 *Safety and Protection*

A. CONTRACTOR shall be solely responsible for initiating, maintaining and supervising all safety precautions and programs in connection with the Work. CONTRACTOR shall take all necessary precautions for the safety of, and shall provide the necessary protection to prevent damage, injury or loss to:

1. all persons on the Site or who may be affected by the Work;
2. all the Work and materials and equipment to be incorporated therein, whether in storage on or off the Site; and
3. other property at the Site or adjacent thereto, including trees, shrubs, lawns, walks, pavements, roadways, structures, utilities, and Underground Facilities not designated for removal, relocation, or replacement in the course of construction.

B. CONTRACTOR shall comply with all applicable Laws and Regulations relating to the safety of persons or property, or to the protection of persons or property from damage, injury, or loss; and shall erect and maintain all necessary safeguards for such safety and protection. CONTRACTOR shall notify owners of adjacent property and of Underground Facilities and other utility owners when prosecution of the Work may affect them, and shall cooperate with them in the protection, removal, relocation, and replacement of their property. All damage, injury, or loss to any property referred to in paragraph 6.13.A.2 or 6.13.A.3 caused, directly or indirectly, in whole or in part, by CONTRACTOR, any Subcontractor, Supplier, or any other individual or entity directly or indirectly employed by any of them to perform any of the Work, or anyone for whose acts any of them may be liable, shall be remedied by CONTRACTOR (except damage or loss attributable to the fault of Drawings or Specifications or to the acts or omissions of OWNER or ENGINEER or ENGINEER's Consultant, or anyone employed by any of them, or anyone for whose acts any of them may be liable, and not attributable, directly or indirectly, in whole or in part, to the fault or negligence of CONTRACTOR or any Subcontractor, Supplier, or other individual or entity directly or indirectly employed by any of them). CONTRACTOR's duties and responsibilities for safety and for protection of the Work shall continue until such time as all the Work is completed and ENGINEER has issued a notice to OWNER and CONTRACTOR in accordance with paragraph 14.07.B that the Work is acceptable (except as otherwise expressly provided in connection with Substantial Completion).

6.14 *Safety Representative*

A. CONTRACTOR shall designate a qualified and experienced safety representative at the Site whose duties and responsibilities shall be the prevention of accidents and the maintaining and supervising of safety precautions and programs.

6.15 *Hazard Communication Programs*

A. CONTRACTOR shall be responsible for coordinating any exchange of material safety data sheets or other hazard communication information required to be made available to or exchanged between or among employers at the Site in accordance with Laws or Regulations.

6.16 *Emergencies*

A. In emergencies affecting the safety or protection of persons or the Work or property at the Site or adjacent thereto, CONTRACTOR is obligated to act to prevent threatened damage, injury, or loss. CONTRACTOR shall give ENGINEER prompt written notice if CONTRACTOR believes that any significant changes in the Work or variations from the Contract Documents have been caused thereby or are required as a result thereof. If ENGINEER determines that a change in the Contract Documents is required because of the action taken by CONTRACTOR in response to such an emergency, a Work Change Directive or Change Order will be issued.

6.17* *Shop Drawings and Samples*

A.* CONTRACTOR shall submit Shop Drawings to ENGINEER for review and approval in accordance with the acceptable schedule of Shop Drawings and Sample submittals. All submittals will be identified as ENGINEER may require and in the number of copies specified in the General Requirements. The data shown on the Shop Drawings will be complete with respect to quantities, dimensions, specified performance and design criteria, materials, and similar data to show ENGINEER the services, materials, and equipment CONTRACTOR proposes to provide and to enable ENGINEER to review the information for the limited purposes required by paragraph 6.17.E.

B.* CONTRACTOR shall also submit six (6) Samples to ENGINEER for review and approval in accordance with the acceptable schedule of Shop Drawings and Sample submittals. Each Sample will be identified clearly as to material, Supplier, pertinent data such as catalog numbers, and the use for which intended and otherwise as ENGINEER may require to enable ENGINEER to review the submittal for the limited purposes required by paragraph 6.17.E. The numbers of each Sample to be submitted will be as specified in the Specifications.

C. Where a Shop Drawing or Sample is required by the Contract Documents or the schedule of Shop Drawings and Sample submittals acceptable to ENGINEER as required by paragraph 2.07, any related Work performed prior to ENGINEER's review and approval of the pertinent submittal will be at the sole expense and responsibility of CONTRACTOR.

D. *Submittal Procedures*

1. Before submitting each Shop Drawing or Sample, CONTRACTOR shall have determined and verified:

a. all field measurements, quantities, dimensions, specified performance criteria, installation requirements, materials, catalog numbers, and similar information with respect thereto;

b. all materials with respect to intended use, fabrication, shipping, handling, storage, assembly, and installation pertaining to the performance of the Work;

c. all information relative to means, methods, techniques, sequences, and procedures of construction and safety precautions and programs incident thereto; and

d. CONTRACTOR shall also have reviewed and coordinated each Shop Drawing or

*See Supplementary Conditions

Sample with other Shop Drawings and Samples and with the requirements of the Work and the Contract Documents.

2. Each submittal shall bear a stamp or specific written indication that CONTRACTOR has satisfied CONTRACTOR's obligations under the Contract Documents with respect to CONTRACTOR's review and approval of that submittal.

3. At the time of each submittal, CONTRACTOR shall give ENGINEER specific written notice of such variations, if any, that the Shop Drawing or Sample submitted may have from the requirements of the Contract Documents, such notice to be in a written communication separate from the submittal; and, in addition, shall cause a specific notation to be made on each Shop Drawing and Sample submitted to ENGINEER for review and approval of each such variation.

E. *ENGINEER's Review*

1. ENGINEER will timely review and approve Shop Drawings and Samples in accordance with the schedule of Shop Drawings and Sample submittals acceptable to ENGINEER. ENGINEER's review and approval will be only to determine if the items covered by the submittals

will, after installation or incorporation in the Work, conform to the information given in the Contract Documents and be compatible with the design concept of the completed Project as a functioning whole as indicated by the Contract Documents.

2. ENGINEER's review and approval will not extend to means, methods, techniques, sequences, or procedures of construction (except where a particular means, method, technique, sequence, or procedure of construction is specifically and expressly called for by the Contract Documents) or to safety precautions or programs incident thereto. The review and approval of a separate item as such will not indicate approval of the assembly in which the item functions.

3. ENGINEER's review and approval of Shop Drawings or Samples shall not relieve CONTRACTOR from responsibility for any variation from the requirements of the Contract Documents unless CONTRACTOR has in writing called ENGINEER's attention to each such variation at the time of each submittal as required by paragraph 6.17.D.3 and ENGINEER has given written approval of each such variation by specific written notation thereof incorporated in or accompanying the Shop Drawing or Sample approval; nor will any approval by ENGINEER relieve CONTRACTOR from responsibility for complying with the requirements of paragraph 6.17.D.1.

F. *Resubmittal Procedures*

1. CONTRACTOR shall make corrections required by ENGINEER and shall return the required number of corrected copies of Shop Drawings and submit as required new Samples for review and approval. CONTRACTOR shall direct specific attention in writing to revisions other than the corrections called for by ENGINEER on previous submittals.

6.18 *Continuing the Work*

A. CONTRACTOR shall carry on the Work and adhere to the progress schedule during all disputes or disagreements with OWNER. No Work shall be delayed or postponed pending resolution of any disputes or disagreements, except as permitted by paragraph 15.04 or as OWNER and CONTRACTOR may otherwise agree in writing.

6.19 *CONTRACTOR's General Warranty and Guarantee*

A. CONTRACTOR warrants and guarantees to OWNER, ENGINEER, and ENGINEER's Consultants that all Work will be in accordance with the Contract Documents and will not be defective. CONTRACTOR's warranty and guarantee hereunder excludes defects or damage caused by:

1. abuse, modification, or improper maintenance or operation by persons other than CONTRACTOR, Subcontractors, Suppliers, or any other individual or entity for whom CONTRACTOR is responsible; or
2. normal wear and tear under normal usage.

B. CONTRACTOR's obligation to perform and complete the Work in accordance with the Contract Documents shall be absolute. None of the following will constitute an acceptance of Work that is not in accordance with the Contract Documents or a release of CONTRACTOR's obligation to perform the Work in accordance with the Contract Documents:

1. observations by ENGINEER;
2. recommendation by ENGINEER or payment by OWNER of any progress or final payment;
3. the issuance of a certificate of Substantial Completion by ENGINEER or any payment related thereto by OWNER;
4. use or occupancy of the Work or any part thereof by OWNER;
5. any acceptance by OWNER or any failure to do so;
6. any review and approval of a Shop Drawing or Sample submittal or the issuance of a notice of acceptability by ENGINEER;
7. any inspection, test, or approval by others; or
8. any correction of defective Work by OWNER.

6.20 *Indemnification*

A. To the fullest extent permitted by Laws and Regulations, CONTRACTOR shall indemnify and hold harmless OWNER, ENGINEER, ENGINEER's Consultants, and the officers, directors, partners, employees, agents, and other consultants and subcontractors of each and any of them from and against all claims, costs, losses, and damages (including but not limited to all fees and charges of engineers, architects, attorneys, and other professionals and all court or arbitration or other dispute resolution costs) arising out of or relating to the performance of the Work, provided that any such claim, cost, loss, or damage:

1. is attributable to bodily injury, sickness, disease, or death, or to injury to or destruction of tangible property (other than the Work itself), including the loss of use resulting therefrom; and

2. is caused in whole or in part by any negligent act or omission of CONTRACTOR, any Subcontractor, any Supplier, or any individual or entity directly or indirectly employed by any of them to perform any of the Work or anyone for whose acts any of them may be liable, regardless of whether or not caused in part by any negligence or omission of an individual or entity indemnified hereunder or whether liability is imposed upon such indemnified party by Laws and Regulations regardless of the negligence of any such individual or entity.

B. In any and all claims against OWNER or ENGINEER or any of their respective consultants, agents, officers, directors, partners, or employees by any employee (or the survivor or personal representative of such employee) of CONTRACTOR, any Subcontractor, any Supplier, or any individual or entity directly or indirectly employed by any of them to perform any of the Work, or anyone for whose acts any of them may be liable, the indemnification obligation under paragraph 6.20.A shall not be limited in any way by any limitation on the amount or type of damages, compensation, or benefits payable by or for CONTRACTOR or any such Subcontractor, Supplier, or other individual or entity under workers' compensation acts, disability benefit acts, or other employee benefit acts.

C. The indemnification obligations of CONTRACTOR under paragraph 6.20.A shall not extend to the liability of ENGINEER and ENGINEER's Consultants or to the officers, directors, partners, employees, agents, and

other consultants and subcontractors of each and any of them arising out of:

1. the preparation or approval of, or the failure to prepare or approve, maps, Drawings, opinions, reports, surveys, Change Orders, designs, or Specifications; or

2. giving directions or instructions, or failing to give them, if that is the primary cause of the injury or damage.

ARTICLE 7 - OTHER WORK

7.01 *Related Work at Site*

A. OWNER may perform other work related to the Project at the Site by OWNER's employees, or let other direct contracts therefor, or have other work performed by utility owners. If such other work is not noted in the Contract Documents, then:

1. written notice thereof will be given to CONTRACTOR prior to starting any such other work; and

2. if OWNER and CONTRACTOR are unable to agree on entitlement to or on the amount or extent, if any, of any adjustment in the Contract Price or Contract Times that should be allowed as a result of such other work, a Claim may be made therefor as provided in paragraph 10.05.

B. CONTRACTOR shall afford each other contractor who is a party to such a direct contract and each utility owner (and OWNER, if OWNER is performing the other work with OWNER's employees) proper and safe access to the Site and a reasonable opportunity for the introduction and storage of materials and equipment and the execution of such other work and shall properly coordinate the Work with theirs. Unless otherwise provided in the Contract Documents, CONTRACTOR shall do all cutting, fitting, and patching of the Work that may be required to properly connect or otherwise make its several parts come together and properly integrate with such other work. CONTRACTOR shall not endanger any work of others by cutting, excavating, or otherwise altering their work and will only cut or alter their work with the written consent of ENGINEER and the others whose work will be affected. The duties and responsibilities of CONTRACTOR under this paragraph are for the benefit of

such utility owners and other contractors to the extent that there are comparable provisions for the benefit of CONTRACTOR in said direct contracts between OWNER and such utility owners and other contractors.

C. If the proper execution or results of any part of CONTRACTOR's Work depends upon work performed by others under this Article 7, CONTRACTOR shall inspect such other work and promptly report to ENGINEER in writing any delays, defects, or deficiencies in such other work that render it unavailable or unsuitable for the proper execution and results of CONTRACTOR's Work. CONTRACTOR's failure to so report will constitute an acceptance of such other work as fit and proper for integration with CONTRACTOR's Work except for latent defects and deficiencies in such other work.

7.02 *Coordination*

A. If OWNER intends to contract with others for the performance of other work on the Project at the Site, the following will be set forth in Supplementary Conditions:

1. the individual or entity who will have authority and responsibility for coordination of the activities among the various contractors will be identified;
2. the specific matters to be covered by such authority and responsibility will be itemized; and
3. the extent of such authority and responsibilities will be provided.

B. Unless otherwise provided in the Supplementary Conditions, OWNER shall have sole authority and responsibility for such coordination.

ARTICLE 8 - OWNER'S RESPONSIBILITIES

8.01 *Communications to Contractor*

A. Except as otherwise provided in these General Conditions, OWNER shall issue all communications to CONTRACTOR through ENGINEER.

8.02 *Replacement of ENGINEER*

A. In case of termination of the employment of ENGINEER, OWNER shall appoint an engineer to whom CONTRACTOR makes no reasonable objection, whose status under the Contract Documents shall be that of the former ENGINEER.

8.03 *Furnish Data*

A. OWNER shall promptly furnish the data required of OWNER under the Contract Documents.

8.04 *Pay Promptly When Due*

A. OWNER shall make payments to CONTRACTOR promptly when they are due as provided in paragraphs 14.02.C and 14.07.C.

8.05 *Lands and Easements; Reports and Tests*

A. OWNER's duties in respect of providing lands and easements and providing engineering surveys to establish reference points are set forth in paragraphs 4.01 and 4.05. Paragraph 4.02 refers to OWNER's identifying and making available to CONTRACTOR copies of reports of explorations and tests of subsurface conditions and drawings of physical conditions in or relating to existing surface or subsurface structures at or contiguous to the Site that have been utilized by ENGINEER in preparing the Contract Documents.

*See Supplementary Conditions

8.06* *Insurance*

A.* OWNER's responsibilities, if any, in respect to purchasing and maintaining liability and property insurance are set forth in Article 5.

8.07 *Change Orders*

A. OWNER is obligated to execute Change Orders as indicated in paragraph 10.03.

8.08 *Inspections, Tests, and Approvals*

A. OWNER's responsibility in respect to certain inspections, tests, and approvals is set forth in paragraph 13.03.B.

8.09 *Limitations on OWNER's Responsibilities*

A. The OWNER shall not supervise, direct, or have control or authority over, nor be responsible for, CONTRACTOR's means, methods, techniques, sequences, or procedures of construction, or the safety precautions and programs incident thereto, or for any failure of CONTRACTOR to comply with Laws and Regulations applicable to the performance of the Work. OWNER will not be responsible for CONTRACTOR's failure to perform the Work in accordance with the Contract Documents.

8.10 *Undisclosed Hazardous Environmental Condition*

A. OWNER's responsibility in respect to an undisclosed Hazardous Environmental Condition is set forth in paragraph 4.06.

8.11 *Evidence of Financial Arrangements*

A. If and to the extent OWNER has agreed to furnish CONTRACTOR reasonable evidence that financial arrangements have been made to satisfy OWNER's obligations under the Contract Documents, OWNER's responsibility in respect thereof will be as set forth in the Supplementary Conditions.

ARTICLE 9 - ENGINEER'S STATUS DURING CONSTRUCTION

9.01 *OWNER'S Representative*

A. ENGINEER will be OWNER's representative during the construction period. The duties and responsibilities and the limitations of authority of ENGINEER as OWNER's representative during construction are set forth in the Contract Documents and will not be changed without written consent of OWNER and ENGINEER.

9.02 *Visits to Site*

A. ENGINEER will make visits to the Site at intervals appropriate to the various stages of construction as ENGINEER deems necessary in order to observe as an experienced and qualified design professional the progress that has been made and the quality of the various aspects of CONTRACTOR's executed Work. Based on information obtained during such visits and

observations, ENGINEER, for the benefit of OWNER, will determine, in general, if the Work is proceeding in accordance with the Contract Documents. ENGINEER will not be required to make exhaustive or continuous inspections on the Site to check the quality or quantity of the Work. ENGINEER's efforts will be directed toward providing for OWNER a greater degree of confidence that the completed Work will conform generally to the Contract Documents. On the basis of such visits and observations, ENGINEER will keep OWNER informed of the progress of the Work and will endeavor to guard OWNER against defective Work.

B. ENGINEER's visits and observations are subject to all the limitations on ENGINEER's authority and responsibility set forth in paragraph 9.10, and particularly, but without limitation, during or as a result of ENGINEER's visits or observations of CONTRACTOR's Work ENGINEER will not supervise, direct, control, or have authority over or be responsible for CONTRACTOR's means, methods, techniques, sequences, or procedures of construction, or the safety precautions and programs incident thereto, or for any failure of CONTRACTOR to comply with Laws and Regulations applicable to the performance of the Work.

9.03* *Project Representative*

A. If OWNER and ENGINEER agree, ENGINEER will furnish a Resident Project Representative to assist ENGINEER in providing more extensive observation of the Work. The responsibilities and authority and limitations thereon of any such Resident Project Representative and assistants will be as provided in paragraph 9.10 and in the Supplementary Conditions. If OWNER designates another representative or agent to represent OWNER at the Site who is not ENGINEER's Consultant, agent or employee,

*See Supplementary Conditions

the responsibilities and authority and limitations thereon of such other individual or entity will be as provided in the Supplementary Conditions.

9.04 *Clarifications and Interpretations*

A. ENGINEER will issue with reasonable promptness such written clarifications or interpretations of the requirements of the Contract Documents as ENGINEER may determine necessary, which shall be consistent with the intent of and reasonably inferable from the Contract Docu-

ments. Such written clarifications and interpretations will be binding on OWNER and CONTRACTOR. If OWNER and CONTRACTOR are unable to agree on entitlement to or on the amount or extent, if any, of any adjustment in the Contract Price or Contract Times, or both, that should be allowed as a result of a written clarification or interpretation, a Claim may be made therefor as provided in paragraph 10.05.

9.05 *Authorized Variations in Work*

A. ENGINEER may authorize minor variations in the Work from the requirements of the Contract Documents which do not involve an adjustment in the Contract Price or the Contract Times and are compatible with the design concept of the completed Project as a functioning whole as indicated by the Contract Documents. These may be accomplished by a Field Order and will be binding on OWNER and also on CONTRACTOR, who shall perform the Work involved promptly. If OWNER and CONTRACTOR are unable to agree on entitlement to or on the amount or extent, if any, of any adjustment in the Contract Price or Contract Times, or both, as a result of a Field Order, a Claim may be made therefor as provided in paragraph 10.05.

9.06 *Rejecting Defective Work*

A. ENGINEER will have authority to disapprove or reject Work which ENGINEER believes to be defective, or that ENGINEER believes will not produce a completed Project that conforms to the Contract Documents or that will prejudice the integrity of the design concept of the completed Project as a functioning whole as indicated by the Contract Documents. ENGINEER will also have authority to require special inspection or testing of the Work as provided in paragraph 13.04, whether or not the Work is fabricated, installed, or completed.

9.07 *Shop Drawings, Change Orders and Payments*

A. In connection with ENGINEER's authority as to Shop Drawings and Samples, see paragraph 6.17.

B. In connection with ENGINEER's authority as to Change Orders, see Articles 10, 11, and 12.

C. In connection with ENGINEER's authority as to Applications for Payment, see Article 14.

9.08 *Determinations for Unit Price Work*

A. ENGINEER will determine the actual quantities and classifications of Unit Price Work performed by CONTRACTOR. ENGINEER will review with CONTRACTOR the ENGINEER's preliminary determinations on such matters before rendering a written decision thereon (by recommendation of an Application for Payment or otherwise). ENGINEER's written decision thereon will be final and binding (except as modified by ENGINEER to reflect changed factual conditions or more accurate data) upon OWNER and CONTRACTOR, subject to the provisions of paragraph 10.05.

9.09 *Decisions on Requirements of Contract Documents and Acceptability of Work*

A. ENGINEER will be the initial interpreter of the requirements of the Contract Documents and judge of the acceptability of the Work thereunder. Claims, disputes and other matters relating to the acceptability of the Work, the quantities and classifications of Unit Price Work, the interpretation of the requirements of the Contract Documents pertaining to the performance of the Work, and Claims seeking changes in the Contract Price or Contract Times will be referred initially to ENGINEER in writing, in accordance with the provisions of paragraph 10.05, with a request for a formal decision.

B. When functioning as interpreter and judge under this paragraph 9.09, ENGINEER will not show partiality to OWNER or CONTRACTOR and will not be liable in connection with any interpretation or decision rendered in good faith in such capacity. The rendering of a decision by ENGINEER pursuant to this paragraph 9.09 with respect to any such Claim, dispute, or other matter (except any which have been waived by the making or acceptance of final payment as provided in paragraph 14.07) will be a condition precedent to any exercise by OWNER or CONTRACTOR of such rights or remedies as either may otherwise have under the Contract Documents or by Laws or Regulations in respect of any such Claim, dispute, or other matter.

*See Supplementary Conditions

9.10 *Limitations on ENGINEER's Authority and Responsibilities*

A. Neither ENGINEER's authority or responsibility under this Article 9 or under any other provision of the Contract Documents nor any decision made by ENGINEER in good faith either to exercise or not exercise such

authority or responsibility or the undertaking, exercise, or performance of any authority or responsibility by ENGINEER shall create, impose, or give rise to any duty in contract, tort, or otherwise owed by ENGINEER to CONTRACTOR, any Subcontractor, any Supplier, any other individual or entity, or to any surety for or employee or agent of any of them.

B. ENGINEER will not supervise, direct, control, or have authority over or be responsible for CONTRACTOR's means, methods, techniques, sequences, or procedures of construction, or the safety precautions and programs incident thereto, or for any failure of CONTRACTOR to comply with Laws and Regulations applicable to the performance of the Work. ENGINEER will not be responsible for CONTRACTOR's failure to perform the Work in accordance with the Contract Documents.

C. ENGINEER will not be responsible for the acts or omissions of CONTRACTOR or of any Subcontractor, any Supplier, or of any other individual or entity performing any of the Work.

D. ENGINEER's review of the final Application for Payment and accompanying documentation and all maintenance and operating instructions, schedules, guarantees, Bonds, certificates of inspection, tests and approvals, and other documentation required to be delivered by paragraph 14.07.A will only be to determine generally that their content complies with the requirements of, and in the case of certificates of inspections, tests, and approvals that the results certified indicate compliance with, the Contract Documents.

E. The limitations upon authority and responsibility set forth in this paragraph 9.10 shall also apply to ENGINEER's Consultants, Resident Project Representative, and assistants. See Article 18.

ARTICLE 10 - CHANGES IN THE WORK; CLAIMS

10.01 *Authorized Changes in the Work*

A. Without invalidating the Agreement and without notice to any surety, OWNER may, at any time or from time to time, order additions, deletions, or revisions in the Work by a Written Amendment, a Change Order, or a Work Change Directive. Upon receipt of any such document, CONTRACTOR shall promptly proceed with the Work involved which will be performed under the

applicable conditions of the Contract Documents (except as otherwise specifically provided).

B. If OWNER and CONTRACTOR are unable to agree on entitlement to, or on the amount or extent, if any, of an adjustment in the Contract Price or Contract Times, or both, that should be allowed as a result of a Work Change Directive, a Claim may be made therefor as provided in paragraph 10.05.

10.02 *Unauthorized Changes in the Work*

A. CONTRACTOR shall not be entitled to an increase in the Contract Price or an extension of the Contract Times with respect to any work performed that is not required by the Contract Documents as amended, modified, or supplemented as provided in paragraph 3.04, except in the case of an emergency as provided in paragraph 6.16 or in the case of uncovering Work as provided in paragraph 13.04.B.

10.03 *Execution of Change Orders*

A. OWNER and CONTRACTOR shall execute appropriate Change Orders recommended by ENGINEER (or Written Amendments) covering:

1. changes in the Work which are: (i) ordered by OWNER pursuant to paragraph 10.01.A, (ii) required because of acceptance of defective Work under paragraph 13.08.A or OWNER's correction of defective Work under paragraph 13.09, or (iii) agreed to by the parties;

2. changes in the Contract Price or Contract Times which are agreed to by the parties, including any undisputed sum or amount of time for Work actually performed in accordance with a Work Change Directive; and

3. changes in the Contract Price or Contract Times which embody the substance of any written decision rendered by ENGINEER pursuant to paragraph 10.05; provided that, in lieu of executing any such Change Order, an appeal may be taken from any such decision in accordance with the provisions of the Contract Documents and applicable Laws and Regulations, but during any such appeal, CONTRACTOR shall carry on the Work and adhere to the progress schedule as provided in paragraph 6.18.A.

10.04 *Notification to Surety*

A. If notice of any change affecting the general scope of the Work or the provisions of the Contract Documents (including, but not limited to, Contract Price or Contract Times) is required by the provisions of any Bond to be given to a surety, the giving of any such notice will be CONTRACTOR's responsibility. The amount of each applicable Bond will be adjusted to reflect the effect of any such change.

10.05 *Claims and Disputes*

A. *Notice:* Written notice stating the general nature of each Claim, dispute, or other matter shall be delivered by the claimant to ENGINEER and the other party to the Contract promptly (but in no event later than 30 days) after the start of the event giving rise thereto. Notice of the amount or extent of the Claim, dispute, or other matter with supporting data shall be delivered to the ENGINEER and the other party to the Contract within 60 days after the start of such event (unless ENGINEER allows additional time for claimant to submit additional or more accurate data in support of such Claim, dispute, or other matter). A Claim for an adjustment in Contract Price shall be prepared in accordance with the provisions of paragraph 12.01.B. A Claim for an adjustment in Contract Time shall be prepared in accordance with the provisions of paragraph 12.02.B. Each Claim shall be accompanied by claimant's written statement that the adjustment claimed is the entire adjustment to which the claimant believes it is entitled as a result of said event. The opposing party shall submit any response to ENGINEER and the claimant within 30 days after receipt of the claimant's last submittal (unless ENGINEER allows additional time).

B. *ENGINEER's Decision:* ENGINEER will render a formal decision in writing within 30 days after receipt of the last submittal of the claimant or the last submittal of the opposing party, if any. ENGINEER's written decision on such Claim, dispute, or other matter will be final and binding upon OWNER and CONTRACTOR unless:

1. an appeal from ENGINEER's decision is taken within the time limits and in accordance with the dispute resolution procedures set forth in Article 16; or

2. if no such dispute resolution procedures have been set forth in Article 16, a written notice of intention to appeal from ENGINEER's written decision is delivered by OWNER or CONTRACTOR to the other and to ENGINEER within 30 days

after the date of such decision, and a formal proceeding is instituted by the appealing party in a forum of competent jurisdiction within 60 days after the date of such decision or within 60 days after Substantial Completion, whichever is later (unless otherwise agreed in writing by OWNER and CONTRACTOR), to exercise such rights or remedies as the appealing party may have with respect to such Claim, dispute, or other matter in accordance with applicable Laws and Regulations.

C. If ENGINEER does not render a formal decision in writing within the time stated in paragraph 10.05.B, a decision denying the Claim in its entirety shall be deemed to have been issued 31 days after receipt of the last submittal of the claimant or the last submittal of the opposing party, if any.

D. No Claim for an adjustment in Contract Price or Contract Times (or Milestones) will be valid if not submitted in accordance with this paragraph 10.05.

ARTICLE 11 - COST OF THE WORK; CASH ALLOWANCES; UNIT PRICE WORK

11.01 *Cost of the Work*

A. *Costs Included:* The term Cost of the Work means the sum of all costs necessarily incurred and paid by CONTRACTOR in the proper performance of the Work. When the value of any Work covered by a Change Order or when a Claim for an adjustment in Contract Price is determined on the basis of Cost of the Work, the costs to be reimbursed to CONTRACTOR will be only those additional or incremental costs required because of the change in the Work or because of the event giving rise to the Claim. Except as otherwise may be agreed to in writing by OWNER, such costs shall be in amounts no higher than those prevailing in the locality of the Project, shall include only the following items, and shall not include any of the costs itemized in paragraph 11.01.B.

1. Payroll costs for employees in the direct employ of CONTRACTOR in the performance of the Work under schedules of job classifications agreed upon by OWNER and CONTRACTOR. Such employees shall include without limitation superintendents, foremen, and other personnel employed full time at the Site. Payroll costs for employees not employed full time on the Work

shall be apportioned on the basis of their time spent on the Work. Payroll costs shall include, but not be limited to, salaries and wages plus the cost of fringe benefits, which shall include social security contributions, unemployment, excise, and payroll taxes, workers' compensation, health and retirement benefits, bonuses, sick leave, vacation and holiday pay applicable thereto. The expenses of performing Work outside of regular working hours, on Saturday, Sunday, or legal holidays, shall be included in the above to the extent authorized by OWNER.

2. Cost of all materials and equipment furnished and incorporated in the Work, including costs of transportation and storage thereof, and Suppliers' field services required in connection therewith. All cash discounts shall accrue to CONTRACTOR unless OWNER deposits funds with CONTRACTOR with which to make payments, in which case the cash discounts shall accrue to OWNER. All trade discounts, rebates and refunds and returns from sale of surplus materials and equipment shall accrue to OWNER, and CONTRACTOR shall make provisions so that they may be obtained.

3. Payments made by CONTRACTOR to Subcontractors for Work performed by Subcontractors. If required by OWNER, CONTRACTOR shall obtain competitive bids from subcontractors acceptable to OWNER and CONTRACTOR and shall deliver such bids to OWNER, who will then determine, with the advice of ENGINEER, which bids, if any, will be acceptable. If any subcontract provides that the Subcontractor is to be paid on the basis of Cost of the Work plus a fee, the Subcontractor's Cost of the Work and fee shall be determined in the same manner as CONTRACTOR's Cost of the Work and fee as provided in this paragraph 11.01.

4. Costs of special consultants (including but not limited to engineers, architects, testing laboratories, surveyors, attorneys, and accountants) employed for services specifically related to the Work.

5. Supplemental costs including the following:

a. The proportion of necessary transportation, travel, and subsistence expenses of

CONTRACTOR's employees incurred in discharge of duties connected with the Work.

b. Cost, including transportation and maintenance, of all materials, supplies, equipment, machinery, appliances, office, and temporary facilities at the Site, and hand tools not owned by the workers, which are consumed in the performance of the Work, and cost, less market value, of such items used but not consumed which remain the property of CONTRACTOR.

c. Rentals of all construction equipment and machinery, and the parts thereof whether rented from CONTRACTOR or others in accordance with rental agreements approved by OWNER with the advice of ENGINEER, and the costs of transportation, loading, unloading, assembly, dismantling, and removal thereof. All such costs shall be in accordance with the terms of said rental agreements. The rental of any such equipment, machinery, or parts shall cease when the use thereof is no longer necessary for the Work.

d. Sales, consumer, use, and other similar taxes related to the Work, and for which CONTRACTOR is liable, imposed by Laws and Regulations.

e. Deposits lost for causes other than negligence of CONTRACTOR, any Subcontractor, or anyone directly or indirectly employed by any of them or for whose acts any of them may be liable, and royalty payments and fees for permits and licenses.

f. Losses and damages (and related expenses) caused by damage to the Work, not compensated by insurance or otherwise, sustained by CONTRACTOR in connection with the performance of the Work (except losses and damages within the deductible amounts of property insurance established in accordance with paragraph 5.06.D), provided such losses and damages have resulted from causes other than the negligence of CONTRACTOR, any Subcontractor, or anyone directly or indirectly employed by any of them or for whose acts any of them may be liable. Such losses shall include settlements made with the written consent and approval of OWNER. No such losses, damages, and expenses shall be included in the Cost of the Work for the purpose of determining CONTRACTOR's fee.

g. The cost of utilities, fuel, and sanitary facilities at the Site.

h. Minor expenses such as telegrams, long distance telephone calls, telephone service at the Site, expressage, and similar petty cash items in connection with the Work.

i. When the Cost of the Work is used to determine the value of a Change Order or of a Claim, the cost of premiums for additional Bonds and insurance required because of the changes in the Work or caused by the event giving rise to the Claim.

j. When all the Work is performed on the basis of cost-plus, the costs of premiums for all Bonds and insurance CONTRACTOR is required by the Contract Documents to purchase and maintain.

B. *Costs Excluded:* The term Cost of the Work shall not include any of the following items:

1. Payroll costs and other compensation of CONTRACTOR's officers, executives, principals (of partnerships and sole proprietorships), general managers, engineers, architects, estimators, attorneys, auditors, accountants, purchasing and contracting agents, expeditors, timekeepers, clerks, and other personnel employed by CONTRACTOR, whether at the Site or in CONTRACTOR's principal or branch office for general administration of the Work and not specifically included in the agreed upon schedule of job classifications referred to in paragraph 11.01.A.1 or specifically covered by paragraph 11.01.A.4, all of which are to be considered administrative costs covered by the CONTRACTOR's fee.

2. Expenses of CONTRACTOR's principal and branch offices other than CONTRACTOR's office at the Site.

3. Any part of CONTRACTOR's capital expenses, including interest on CONTRACTOR's capital employed for the Work and charges against CONTRACTOR for delinquent payments.

4. Costs due to the negligence of CONTRACTOR, any Subcontractor, or anyone directly or indirectly employed by any of them or for whose acts any of them may be liable, including but not

limited to, the correction of defective Work, disposal of materials or equipment wrongly supplied, and making good any damage to property.

5. Other overhead or general expense costs of any kind and the costs of any item not specifically and expressly included in paragraphs 11.01.A and 11.01.B.

C. *CONTRACTOR's Fee:* When all the Work is performed on the basis of cost-plus, CONTRACTOR's fee shall be determined as set forth in the Agreement. When the value of any Work covered by a Change Order or when a Claim for an adjustment in Contract Price is determined on the basis of Cost of the Work, CONTRACTOR's fee shall be determined as set forth in paragraph 12.01.C.

D. *Documentation:* Whenever the Cost of the Work for any purpose is to be determined pursuant to paragraphs 11.01.A and 11.01.B, CONTRACTOR will establish and maintain records thereof in accordance with generally accepted accounting practices and submit in a form acceptable to ENGINEER an itemized cost breakdown together with supporting data.

11.02 *Cash Allowances*

A. It is understood that CONTRACTOR has included in the Contract Price all allowances so named in the Contract Documents and shall cause the Work so covered to be performed for such sums as may be acceptable to OWNER and ENGINEER. CONTRACTOR agrees that:

1. the allowances include the cost to CONTRACTOR (less any applicable trade discounts) of materials and equipment required by the allowances to be delivered at the Site, and all applicable taxes; and

2. CONTRACTOR's costs for unloading and handling on the Site, labor, installation costs, overhead, profit, and other expenses contemplated for the allowances have been included in the Contract Price and not in the allowances, and no demand for additional payment on account of any of the foregoing will be valid.

B. Prior to final payment, an appropriate Change Order will be issued as recommended by ENGINEER to reflect actual amounts due CONTRACTOR on account of

Work covered by allowances, and the Contract Price shall be correspondingly adjusted.

11.03 *Unit Price Work*

A. Where the Contract Documents provide that all or part of the Work is to be Unit Price Work, initially the Contract Price will be deemed to include for all Unit Price Work an amount equal to the sum of the unit price for each separately identified item of Unit Price Work times the estimated quantity of each item as indicated in the Agreement. The estimated quantities of items of Unit Price Work are not guaranteed and are solely for the purpose of comparison of Bids and determining an initial Contract Price. Determinations of the actual quantities and classifications of Unit Price Work performed by CONTRACTOR will be made by ENGINEER subject to the provisions of paragraph 9.08.

B. Each unit price will be deemed to include an amount considered by CONTRACTOR to be adequate to cover CONTRACTOR's overhead and profit for each separately identified item.

C. OWNER or CONTRACTOR may make a Claim for an adjustment in the Contract Price in accordance with paragraph 10.05 if:

1. the quantity of any item of Unit Price Work performed by CONTRACTOR differs materially and significantly from the estimated quantity of such item indicated in the Agreement; and
2. there is no corresponding adjustment with respect any other item of Work; and
3. if CONTRACTOR believes that CONTRACTOR is entitled to an increase in Contract Price as a result of having incurred additional expense or OWNER believes that OWNER is entitled to a decrease in Contract Price and the parties are unable to agree as to the amount of any such increase or decrease.

ARTICLE 12 - CHANGE OF CONTRACT PRICE;
CHANGE OF CONTRACT TIMES

12.01* *Change of Contract Price*

A. The Contract Price may only be changed by a Change Order or by a Written Amendment. Any Claim for an adjustment in the Contract Price shall be based on written notice submitted by the party making the Claim to the ENGINEER and the other party to the Contract in accordance with the provisions of paragraph 10.05.

B.* The value of any Work covered by a Change Order or of any Claim for an adjustment in the Contract Price will be determined as follows:

1. where the Work involved is covered by unit prices contained in the Contract Documents, by application of such unit prices to the quantities of the items involved (subject to the provisions of paragraph 11.03); or
2. where the Work involved is not covered by unit prices contained in the Contract Documents, by a mutually agreed lump sum (which may include an allowance for overhead and profit not necessarily in accordance with paragraph 12.01.C.2); or
3. where the Work involved is not covered by unit prices contained in the Contract Documents and agreement to a lump sum is not reached under paragraph 12.01.B.2, on the basis of the Cost of the Work (determined as provided in paragraph 11.01) plus a CONTRACTOR's fee for overhead and profit (determined as provided in paragraph 12.01.C).

C. *CONTRACTOR's Fee:* The CONTRACTOR's fee for overhead and profit shall be determined as follows:

1. a mutually acceptable fixed fee; or
2. if a fixed fee is not agreed upon, then a fee based on the following percentages of the various portions of the Cost of the Work:
 - a. for costs incurred under paragraphs 11.01.A.1 and 11.01.A.2, the CONTRACTOR's fee shall be 15 percent;

b. for costs incurred under paragraph 11.01.A.3, the CONTRACTOR's fee shall be five percent;

c. where one or more tiers of subcontracts are on the basis of Cost of the Work plus a fee and no fixed fee is agreed upon, the intent of paragraph 12.01.C.2.a is that the Subcontractor who actually performs the Work, at whatever tier, will be paid a fee of 15 percent of the costs incurred by such Subcontractor under paragraphs 11.01.A.1 and 11.01.A.2 and that any higher tier Subcontractor and CONTRACTOR will each be paid a fee of five percent of the amount paid to the next lower tier Subcontractor;

*See Supplementary Conditions

d. no fee shall be payable on the basis of costs itemized under paragraphs 11.01.A.4, 11.01.A.5, and 11.01.B;

e. the amount of credit to be allowed by CONTRACTOR to OWNER for any change which results in a net decrease in cost will be the amount of the actual net decrease in cost plus a deduction in CONTRACTOR's fee by an amount equal to five percent of such net decrease; and

f. when both additions and credits are involved in any one change, the adjustment in CONTRACTOR's fee shall be computed on the basis of the net change in accordance with paragraphs 12.01.C.2.a through 12.01.C.2.e, inclusive.

12.02 *Change of Contract Times*

A. The Contract Times (or Milestones) may only be changed by a Change Order or by a Written Amendment. Any Claim for an adjustment in the Contract Times (or Milestones) shall be based on written notice submitted by the party making the claim to the ENGINEER and the other party to the Contract in accordance with the provisions of paragraph 10.05.

B. Any adjustment of the Contract Times (or Milestones) covered by a Change Order or of any Claim for an adjustment in the Contract Times (or Milestones)

will be determined in accordance with the provisions of this Article 12.

12.03 *Delays Beyond CONTRACTOR's Control*

A. Where CONTRACTOR is prevented from completing any part of the Work within the Contract Times (or Milestones) due to delay beyond the control of CONTRACTOR, the Contract Times (or Milestones) will be extended in an amount equal to the time lost due to such delay if a Claim is made therefor as provided in paragraph 12.02.A. Delays beyond the control of CONTRACTOR shall include, but not be limited to, acts or neglect by OWNER, acts or neglect of utility owners or other contractors performing other work as contemplated by Article 7, fires, floods, epidemics, abnormal weather conditions, or acts of God.

12.04 *Delays Within CONTRACTOR's Control*

A. The Contract Times (or Milestones) will not be extended due to delays within the control of CONTRACTOR. Delays attributable to and within the control of a Subcontractor or Supplier shall be deemed to be delays within the control of CONTRACTOR.

12.05 *Delays Beyond OWNER's and CONTRACTOR's Control*

A. Where CONTRACTOR is prevented from completing any part of the Work within the Contract Times (or Milestones) due to delay beyond the control of both OWNER and CONTRACTOR, an extension of the Contract Times (or Milestones) in an amount equal to the time lost due to such delay shall be CONTRACTOR's sole and exclusive remedy for such delay.

12.06 *Delay Damages*

A. In no event shall OWNER or ENGINEER be liable to CONTRACTOR, any Subcontractor, any Supplier, or any other person or organization, or to any surety for or employee or agent of any of them, for damages arising out of or resulting from:

1. delays caused by or within the control of CONTRACTOR; or

2. delays beyond the control of both OWNER and CONTRACTOR including but not limited to fires, floods, epidemics, abnormal weather conditions, acts of God, or acts or neglect by utility

owners or other contractors performing other work as contemplated by Article 7.

B. Nothing in this paragraph 12.06 bars a change in Contract Price pursuant to this Article 12 to compensate CONTRACTOR due to delay, interference, or disruption directly attributable to actions or inactions of OWNER or anyone for whom OWNER is responsible.

ARTICLE 13 - TESTS AND INSPECTIONS;
CORRECTION, REMOVAL OR ACCEPTANCE OF
DEFECTIVE WORK

13.01 *Notice of Defects*

A. Prompt notice of all defective Work of which OWNER or ENGINEER has actual knowledge will be given to CONTRACTOR. All defective Work may be rejected, corrected, or accepted as provided in this Article 13.

13.02* *Access to Work*

A. OWNER, ENGINEER, ENGINEER's Consultants, other representatives and personnel of OWNER, independent testing laboratories, and governmental agencies with jurisdictional interests will have access to the Site and the Work at reasonable times for their observation, inspecting, and testing. CONTRACTOR shall provide them proper and safe conditions for such access and advise them of CONTRACTOR's Site safety procedures and programs so that they may comply therewith as applicable.

13.03* *Tests and Inspections*

A. CONTRACTOR shall give ENGINEER timely notice of readiness of the Work for all required inspections, tests, or approvals and shall cooperate with inspection and testing personnel to facilitate required inspections or tests.

B.* OWNER shall employ and pay for the services of an independent testing laboratory to perform all inspections, tests, or approvals required by the Contract Documents except:

1. for inspections, tests, or approvals covered by paragraphs 13.03.C and 13.03.D below;

2. that costs incurred in connection with tests or inspections conducted pursuant to paragraph 13.04.B shall be paid as provided in said paragraph 13.04.B; and

3. as otherwise specifically provided in the Contract Documents.

C. If Laws or Regulations of any public body having jurisdiction require any Work (or part thereof) specifically to be inspected, tested, or approved by an employee or other representative of such public body, CONTRACTOR shall assume full responsibility for arranging and obtaining such inspections, tests, or approvals, pay all costs in connection therewith, and furnish ENGINEER the required certificates of inspection or approval.

D. CONTRACTOR shall be responsible for arranging and obtaining and shall pay all costs in connection with any inspections, tests, or approvals required for OWNER's and ENGINEER's acceptance of materials or equipment to be incorporated in the Work; or acceptance of materials, mix designs, or equipment submitted for approval prior to CONTRACTOR's purchase thereof for incorporation in the Work. Such inspections, tests, or approvals shall be performed by organizations acceptable to OWNER and ENGINEER.

E. If any Work (or the work of others) that is to be inspected, tested, or approved is covered by CONTRACTOR without written concurrence of ENGINEER, it must, if requested by ENGINEER, be uncovered for observation.

F. Uncovering Work as provided in paragraph 13.03.E shall be at CONTRACTOR's expense unless CONTRACTOR has given ENGINEER timely notice of CONTRACTOR's intention to cover the same and ENGINEER has not acted with reasonable promptness in response to such notice.

13.04 *Uncovering Work*

A. If any Work is covered contrary to the written request of ENGINEER, it must, if requested by ENGINEER, be uncovered for ENGINEER's observation and replaced at CONTRACTOR's expense.

B. If ENGINEER considers it necessary or advisable that covered Work be observed by ENGINEER or inspected or tested by others, CONTRACTOR, at ENGINEER's request, shall uncover, expose, or otherwise make available for observation, inspection, or testing as ENGINEER may require, that portion of the Work in

question, furnishing all necessary labor, material, and equipment. If it is found that such Work is defective, CONTRACTOR shall pay all Claims, costs, losses, and damages (including but not limited to all fees and charges of engineers, architects, attorneys, and other professionals and all court or arbitration or other dispute resolution costs) arising out of or relating to such uncovering, exposure, observation, inspection, and testing, and of satisfactory replacement or reconstruction (including but not limited to all costs of repair or replacement of work of others); and OWNER shall be entitled to an appropriate decrease in the Contract Price. If the parties are unable to agree as to the amount thereof, OWNER may make a Claim therefor as provided in paragraph 10.05. If, however, such Work is not found to be defective, CONTRACTOR shall be allowed an increase in the Contract Price or an extension of the Contract Times (or Milestones), or both, directly attributable to such uncovering, exposure, observation, inspection, testing, replacement, and reconstruction. If the parties are unable to agree as to the amount or extent thereof, CONTRACTOR may make a Claim therefor as provided in paragraph 10.05.

*See Supplementary Conditions

13.05 *OWNER May Stop the Work*

A. If the Work is defective, or CONTRACTOR fails to supply sufficient skilled workers or suitable materials or equipment, or fails to perform the Work in such a way that the completed Work will conform to the Contract Documents, OWNER may order CONTRACTOR to stop the Work, or any portion thereof, until the cause for such order has been eliminated; however, this right of OWNER to stop the Work shall not give rise to any duty on the part of OWNER to exercise this right for the benefit of CONTRACTOR, any Subcontractor, any Supplier, any other individual or entity, or any surety for, or employee or agent of any of them.

13.06 *Correction or Removal of Defective Work*

A. CONTRACTOR shall correct all defective Work, whether or not fabricated, installed, or completed, or, if the Work has been rejected by ENGINEER, remove it from the Project and replace it with Work that is not defective. CONTRACTOR shall pay all Claims, costs, losses, and damages (including but not limited to all fees and charges of engineers, architects, attorneys, and other professionals and all court or arbitration or other dispute resolution costs) arising out of or relating to such correction or removal (including but not limited to all costs of repair or replacement of work of others).

13.07 *Correction Period*

A. If within one year after the date of Substantial Completion or such longer period of time as may be prescribed by Laws or Regulations or by the terms of any applicable special guarantee required by the Contract Documents or by any specific provision of the Contract Documents, any Work is found to be defective, or if the repair of any damages to the land or areas made available for CONTRACTOR's use by OWNER or permitted by Laws and Regulations as contemplated in paragraph 6.11.A is found to be defective, CONTRACTOR shall promptly, without cost to OWNER and in accordance with OWNER's written instructions: (i) repair such defective land or areas, or (ii) correct such defective Work or, if the defective Work has been rejected by OWNER, remove it from the Project and replace it with Work that is not defective, and (iii) satisfactorily correct or repair or remove and replace any damage to other Work, to the work of others or other land or areas resulting therefrom. If CONTRACTOR does not promptly comply with the terms of such instructions, or in an emergency where delay would cause serious risk of loss or damage, OWNER may have the defective Work corrected or repaired or may have the rejected Work removed and replaced, and all Claims, costs, losses, and damages (including but not limited to all fees and charges of engineers, architects, attorneys, and other professionals and all court or arbitration or other dispute resolution costs) arising out of or relating to such correction or repair or such removal and replacement (including but not limited to all costs of repair or replacement of work of others) will be paid by CONTRACTOR.

B. In special circumstances where a particular item of equipment is placed in continuous service before Substantial Completion of all the Work, the correction period for that item may start to run from an earlier date if so provided in the Specifications or by Written Amendment.

C. Where defective Work (and damage to other Work resulting therefrom) has been corrected or removed and replaced under this paragraph 13.07, the correction period hereunder with respect to such Work will be extended for an additional period of one year after such correction or removal and replacement has been satisfactorily completed.

D. CONTRACTOR's obligations under this paragraph 13.07 are in addition to any other obligation or warranty. The provisions of this paragraph 13.07 shall not be construed as a substitute for or a waiver of the provisions of any applicable statute of limitation or repose.

13.08 *Acceptance of Defective Work*

A. If, instead of requiring correction or removal and replacement of defective Work, OWNER (and, prior to ENGINEER's recommendation of final payment, ENGINEER) prefers to accept it, OWNER may do so. CONTRACTOR shall pay all Claims, costs, losses, and damages (including but not limited to all fees and charges of engineers, architects, attorneys, and other professionals and all court or arbitration or other dispute resolution costs) attributable to OWNER's evaluation of and determination to accept such defective Work (such costs to be approved by ENGINEER as to reasonableness) and the diminished value of the Work to the extent not otherwise paid by CONTRACTOR pursuant to this sentence. If any such acceptance occurs prior to ENGINEER's recommendation of final payment, a Change Order will be issued incorporating the necessary revisions in the Contract Documents with respect to the Work, and OWNER shall be entitled to an appropriate decrease in the Contract Price, reflecting the diminished value of Work so accepted. If the parties are unable to agree as to the amount thereof, OWNER may make a Claim therefor as provided in paragraph 10.05. If the acceptance occurs after such recommendation, an appropriate amount will be paid by CONTRACTOR to OWNER.

13.09 *OWNER May Correct Defective Work*

A. If CONTRACTOR fails within a reasonable time after written notice from ENGINEER to correct defective Work or to remove and replace rejected Work as required by ENGINEER in accordance with paragraph 13.06.A, or if CONTRACTOR fails to perform the Work in accordance with the Contract Documents, or if CONTRACTOR fails to comply with any other provision of the Contract Documents, OWNER may, after seven days written notice

to CONTRACTOR, correct and remedy any such deficiency.

B. In exercising the rights and remedies under this paragraph, OWNER shall proceed expeditiously. In connection with such corrective and remedial action, OWNER may exclude CONTRACTOR from all or part of the Site, take possession of all or part of the Work and suspend CONTRACTOR's services related thereto, take possession of CONTRACTOR's tools, appliances, construction equipment and machinery at the Site, and incorporate in the Work all materials and equipment stored at the Site or for which OWNER has paid CONTRACTOR but which are stored elsewhere. CONTRACTOR shall allow OWNER, OWNER's representatives, agents and employees, OWNER's other contractors, and ENGINEER and ENGINEER's Consultants access to the Site to enable OWNER to exercise the rights and remedies under this paragraph.

C. All Claims, costs, losses, and damages (including but not limited to all fees and charges of engineers, architects, attorneys, and other professionals and all court or arbitration or other dispute resolution costs) incurred or sustained by OWNER in exercising the rights and remedies under this paragraph 13.09 will be charged against CONTRACTOR, and a Change Order will be issued incorporating the necessary revisions in the Contract Documents with respect to the Work; and OWNER shall be entitled to an appropriate decrease in the Contract Price. If the parties are unable to agree as to the amount of the adjustment, OWNER may make a Claim therefor as provided in paragraph 10.05. Such claims, costs, losses and damages will include but not be limited to all costs of repair, or replacement of work of others destroyed or damaged by correction, removal, or replacement of CONTRACTOR's defective Work.

D. CONTRACTOR shall not be allowed an extension of the Contract Times (or Milestones) because of any delay in the performance of the Work attributable to the exercise by OWNER of OWNER's rights and remedies under this paragraph 13.09.

ARTICLE 14 - PAYMENTS TO CONTRACTOR AND COMPLETION

14.01 *Schedule of Values*

A. The schedule of values established as provided in paragraph 2.07.A will serve as the basis for progress payments and will be incorporated into a form of Application for Payment acceptable to ENGINEER. Progress payments on account of Unit Price Work will be based on the number of units completed.

14.02 *Progress Payments*

A.* *Applications for Payments*

1. At least 20 days before the date established for each progress payment (but not more often than once a month), CONTRACTOR shall submit to ENGINEER for review an Application for Payment filled out and signed by CONTRACTOR covering the Work completed as of the date of the Application and accompanied by such supporting documentation as is required by the Contract Documents. If payment is requested on the basis of materials and equipment not incorporated in the Work but delivered and suitably stored at the Site or at another location agreed to in writing, the Application for Payment shall also be accompanied by a bill of sale, invoice, or other documentation warranting that OWNER has received the materials and equipment free and clear of all Liens and evidence that the materials and equipment are covered by appropriate property insurance or other arrangements to protect OWNER's interest therein, all of which must be satisfactory to OWNER.

2. Beginning with the second Application for Payment, each Application shall include an affidavit of CONTRACTOR stating that all previous progress payments received on account of the Work have been applied on account to discharge CONTRACTOR's legitimate obligations associated with prior Applications for Payment.

3. The amount of retainage with respect to pro-gress payments will be as stipulated in the Agreement.

*See Supplementary Conditions

B. *Review of Applications*

1. ENGINEER will, within 10 days after receipt of each Application for Payment, either indicate in writing a recommendation of payment and present the Application to OWNER or return the Application to CONTRACTOR indicating in writing ENGINEER's reasons for refusing to recommend payment. In the latter case, CONTRACTOR may make the necessary corrections and resubmit the Application.

2. ENGINEER's recommendation of any payment requested in an Application for Payment will constitute a representation by ENGINEER to OWNER, based on ENGINEER's observations on the Site of the executed Work as an experienced and qualified design professional and on ENGINEER's review of the Application for Payment and the accompanying data and schedules, that to the best of ENGINEER's knowledge, information and belief:

a. the Work has progressed to the point indicated;

b. the quality of the Work is generally in accordance with the Contract Documents (subject to an evaluation of the Work as a functioning whole prior to or upon Substantial Completion, to the results of any subsequent tests called for in the Contract Documents, to a final determination of quantities and classifications for Unit Price Work under paragraph 9.08, and to any other qualifications stated in the recommendation); and

c. the conditions precedent to CONTRACTOR's being entitled to such payment appear to have been fulfilled in so far as it is ENGINEER's responsibility to observe the Work.

3. By recommending any such payment ENGINEER will not thereby be deemed to have represented that: (i) inspections made to check the quality or the quantity of the Work as it has been performed have been exhaustive, extended to every aspect of the Work in progress, or involved detailed inspections of the Work beyond the responsibilities specifically assigned to ENGINEER in the Contract Documents; or (ii) that there may not be other matters or issues between the parties

that might entitle CONTRACTOR to be paid additionally by OWNER or entitle OWNER to withhold payment to CONTRACTOR.

4. Neither ENGINEER's review of CONTRACTOR's Work for the purposes of recommending payments nor ENGINEER's recommendation of any payment, including final payment, will impose responsibility on ENGINEER to supervise, direct, or control the Work or for the means, methods, techniques, sequences, or procedures of construction, or the safety precautions and programs incident thereto, or for CONTRACTOR's failure to comply with Laws and Regulations applicable to CONTRACTOR's performance of the Work. Additionally, said review or recommendation will not impose responsibility on ENGINEER to make any examination to ascertain how or for what purposes CONTRACTOR has used the moneys paid on account of the Contract Price, or to determine that title to any of the Work, materials, or equipment has passed to OWNER free and clear of any Liens.

5. ENGINEER may refuse to recommend the whole or any part of any payment if, in ENGINEER's opinion, it would be incorrect to make the representations to OWNER referred to in paragraph 14.02.B.2. ENGINEER may also refuse to recommend any such payment or, because of subsequently discovered evidence or the results of subsequent inspections or tests, revise or revoke any such payment recommendation previously made, to such extent as may be necessary in ENGINEER's opinion to protect OWNER from loss because:

- a. the Work is defective, or completed Work has been damaged, requiring correction or replacement;
- b. the Contract Price has been reduced by Written Amendment or Change Orders;
- c. OWNER has been required to correct defective Work or complete Work in accordance with paragraph 13.09; or
- d. ENGINEER has actual knowledge of the occurrence of any of the events enumerated in paragraph 15.02.A.

C. *Payment Becomes Due*

1. Ten days after presentation of the Application for Payment to OWNER with ENGINEER's recommendation, the amount recommended will (subject to the provisions of paragraph 14.02.D) become due, and when due will be paid by OWNER to CONTRACTOR.

D. *Reduction in Payment*

1. OWNER may refuse to make payment of the full amount recommended by ENGINEER because:

a. claims have been made against OWNER on account of CONTRACTOR's performance or furnishing of the Work;

b. Liens have been filed in connection with the Work, except where CONTRACTOR has delivered a specific Bond satisfactory to OWNER to secure the satisfaction and discharge of such Liens;

c. there are other items entitling OWNER to a set-off against the amount recommended; or

d. OWNER has actual knowledge of the occurrence of any of the events enumerated in paragraphs 14.02.B.5.a through 14.02.B.5.c or paragraph 15.02.A.

2. If OWNER refuses to make payment of the full amount recommended by ENGINEER, OWNER must give CONTRACTOR immediate written notice (with a copy to ENGINEER) stating the reasons for such action and promptly pay CONTRACTOR any amount remaining after deduction of the amount so withheld. OWNER shall promptly pay CONTRACTOR the amount so withheld, or any adjustment thereto agreed to by OWNER and CONTRACTOR, when CONTRACTOR corrects to OWNER's satisfaction the reasons for such action.

3. If it is subsequently determined that OWNER's refusal of payment was not justified, the amount wrongfully withheld shall be treated as an amount due as determined by paragraph 14.02.C.1.

14.03 *CONTRACTOR's Warranty of Title*

A. CONTRACTOR warrants and guarantees that title to all Work, materials, and equipment covered by any Application for Payment, whether incorporated in the Project or not, will pass to OWNER no later than the time of payment free and clear of all Liens.

14.04 *Substantial Completion*

A. When CONTRACTOR considers the entire Work ready for its intended use CONTRACTOR shall notify OWNER and ENGINEER in writing that the entire Work is substantially complete (except for items specifically listed by CONTRACTOR as incomplete) and request that ENGINEER issue a certificate of Substantial Completion. Promptly thereafter, OWNER, CONTRACTOR, and ENGINEER shall make an inspection of the Work to determine the status of completion. If ENGINEER does not consider the Work substantially complete, ENGINEER will notify CONTRACTOR in writing giving the reasons therefor. If ENGINEER considers the Work substantially complete, ENGINEER will prepare and deliver to OWNER a tentative certificate of Substantial Completion which shall fix the date of Substantial Completion. There shall be attached to the certificate a tentative list of items to be completed or corrected before final payment. OWNER shall have seven days after receipt of the tentative certificate during which to make written objection to ENGINEER as to any provisions of the certificate or attached list. If, after considering such objections, ENGINEER concludes that the Work is not substantially complete, ENGINEER will within 14 days after submission of the tentative certificate to OWNER notify CONTRACTOR in writing, stating the reasons therefor. If, after consideration of OWNER's objections, ENGINEER considers the Work substantially complete, ENGINEER will within said 14 days execute and deliver to OWNER and CONTRACTOR a definitive certificate of Substantial Completion (with a revised tentative list of items to be completed or corrected) reflecting such changes from the tentative certificate as ENGINEER believes justified after consideration of any objections from OWNER. At the time of delivery of the tentative certificate of Substantial Completion ENGINEER will deliver to OWNER and CONTRACTOR a written recommendation as to division of responsibilities pending final payment between OWNER and CONTRACTOR with respect to security, operation, safety, and protection of the Work, maintenance, heat, utilities, insurance, and warranties and guarantees. Unless OWNER and CONTRACTOR agree otherwise in writing and so inform ENGINEER in writing prior to ENGINEER's issuing the definitive certificate of Substantial Completion,

ENGINEER's aforesaid recommendation will be binding on OWNER and CONTRACTOR until final payment.

B. OWNER shall have the right to exclude CONTRACTOR from the Site after the date of Substantial Completion, but OWNER shall allow CONTRACTOR reasonable access to complete or correct items on the tentative list.

14.05 *Partial Utilization*

A. Use by OWNER at OWNER's option of any substantially completed part of the Work which has specifically been identified in the Contract Documents, or which OWNER, ENGINEER, and CONTRACTOR agree constitutes a separately functioning and usable part of the Work that can be used by OWNER for its intended purpose without significant interference with CONTRACTOR's performance of the remainder of the Work, may be accomplished prior to Substantial Completion of all the Work subject to the following conditions.

1. OWNER at any time may request CONTRACTOR in writing to permit OWNER to use any such part of the Work which OWNER believes to be ready for its intended use and substantially complete. If CONTRACTOR agrees that such part of the Work is substantially complete, CONTRACTOR will certify to OWNER and ENGINEER that such part of the Work is substantially complete and request ENGINEER to issue a certificate of Substantial Completion for that part of the Work. CONTRACTOR at any time may notify OWNER and ENGINEER in writing that CONTRACTOR considers any such part of the Work ready for its intended use and substantially complete and request ENGINEER to issue a certificate of Substantial Completion for that part of the Work. Within a reasonable time after either such request, OWNER, CONTRACTOR, and ENGINEER shall make an inspection of that part of the Work to determine its status of completion. If ENGINEER does not consider that part of the Work to be substantially complete, ENGINEER will notify OWNER and CONTRACTOR in writing giving the reasons therefor. If ENGINEER considers that part of the Work to be substantially complete, the provisions of paragraph 14.04 will apply with respect to certification of Substantial Completion of that part of the Work and the division of responsibility in respect thereof and access thereto.

2. No occupancy or separate operation of part of the Work may occur prior to compliance with the requirements of paragraph 5.10 regarding property insurance.

14.06 *Final Inspection*

A. Upon written notice from CONTRACTOR that the entire Work or an agreed portion thereof is complete, ENGINEER will promptly make a final inspection with OWNER and CONTRACTOR and will notify CONTRACTOR in writing of all particulars in which this inspection reveals that the Work is incomplete or defective. CONTRACTOR shall immediately take such measures as are necessary to complete such Work or remedy such deficiencies.

14.07 *Final Payment*

A. *Application for Payment*

1. After CONTRACTOR has, in the opinion of ENGINEER, satisfactorily completed all corrections identified during the final inspection and has delivered, in accordance with the Contract Documents, all maintenance and operating instructions, schedules, guarantees, Bonds, certificates or other evidence of insurance certificates of inspection, marked-up record documents (as provided in paragraph 6.12), and other documents, CONTRACTOR may make application for final payment following the procedure for progress payments.

2. The final Application for Payment shall be accompanied (except as previously delivered) by: (i) all documentation called for in the Contract Documents, including but not limited to the evidence of insurance required by subparagraph 5.04.B.7; (ii) consent of the surety, if any, to final payment; and (iii) complete and legally effective releases or waivers (satisfactory to OWNER) of all Lien rights arising out of or Liens filed in connection with the Work.

3. In lieu of the releases or waivers of Liens specified in paragraph 14.07.A.2 and as approved by OWNER, CONTRACTOR may furnish receipts or releases in full and an affidavit of CONTRACTOR that: (i) the releases and receipts include all labor, services, material, and equipment for which a Lien could be filed; and (ii) all payrolls, material and equipment bills, and other

indebtedness connected with the Work for which OWNER or OWNER's property might in any way be responsible have been paid or otherwise satisfied. If any Subcontractor or Supplier fails to furnish such a release or receipt in full, CONTRACTOR may furnish a Bond or other collateral satisfactory to OWNER to indemnify OWNER against any Lien.

B. *Review of Application and Acceptance*

1. If, on the basis of ENGINEER's observation of the Work during construction and final inspection, and ENGINEER's review of the final Application for Payment and accompanying documentation as required by the Contract Documents, ENGINEER is satisfied that the Work has been completed and CONTRACTOR's other obligations under the Contract Documents have been fulfilled, ENGINEER will, within ten days after receipt of the final Application for Payment, indicate in writing ENGINEER's recommendation of payment and present the Application for Payment to OWNER for payment. At the same time ENGINEER will also give written notice to OWNER and CONTRACTOR that the Work is acceptable subject to the provisions of paragraph 14.09. Otherwise, ENGINEER will return the Application for Payment to CONTRACTOR, indicating in writing the reasons for refusing to recommend final payment, in which case CONTRACTOR shall make the necessary corrections and resubmit the Application for Payment.

C. *Payment Becomes Due*

1. Thirty days after the presentation to OWNER of the Application for Payment and accompanying documentation, the amount recommended by ENGINEER will become due and, when due, will be paid by OWNER to CONTRACTOR.

14.08 *Final Completion Delayed*

A. If, through no fault of CONTRACTOR, final completion of the Work is significantly delayed, and if ENGINEER so confirms, OWNER shall, upon receipt of CONTRACTOR's final Application for Payment and recommendation of ENGINEER, and without terminating the Agreement, make payment of the balance due for that portion of the Work fully completed and accepted. If the remaining balance to be held by OWNER for Work not

fully completed or corrected is less than the retainage stipulated in the Agreement, and if Bonds have been furnished as required in paragraph 5.01, the written consent of the surety to the payment of the balance due for that portion of the Work fully completed and accepted shall be submitted by CONTRACTOR to ENGINEER with the Application for such payment. Such payment shall be made under the terms and conditions governing final payment, except that it shall not constitute a waiver of Claims.

14.09 *Waiver of Claims*

A. The making and acceptance of final payment will constitute:

1. a waiver of all Claims by OWNER against CONTRACTOR, except Claims arising from unsettled Liens, from defective Work appearing after final inspection pursuant to paragraph 14.06, from failure to comply with the Contract Documents or the terms of any special guarantees specified therein, or from CONTRACTOR's continuing obligations under the Contract Documents; and

2. a waiver of all Claims by CONTRACTOR against OWNER other than those previously made in writing which are still unsettled.

ARTICLE 15 - SUSPENSION OF WORK AND TERMINATION

15.01 *OWNER May Suspend Work*

A. At any time and without cause, OWNER may suspend the Work or any portion thereof for a period of not more than 90 consecutive days by notice in writing to CONTRACTOR and ENGINEER which will fix the date on which Work will be resumed. CONTRACTOR shall resume the Work on the date so fixed. CONTRACTOR shall be allowed an adjustment in the Contract Price or an extension of the Contract Times, or both, directly attributable to any such suspension if CONTRACTOR makes a Claim therefor as provided in paragraph 10.05.

15.02 *OWNER May Terminate for Cause*

A. The occurrence of any one or more of the following events will justify termination for cause:

1. CONTRACTOR's persistent failure to perform the Work in accordance with the Contract Documents (including, but not limited to, failure to supply sufficient skilled workers or suitable materials or equipment or failure to adhere to the progress schedule established under paragraph 2.07 as adjusted from time to time pursuant to paragraph 6.04);

2. CONTRACTOR's disregard of Laws or Regulations of any public body having jurisdiction;

3. CONTRACTOR's disregard of the authority of ENGINEER; or

4. CONTRACTOR's violation in any substantial way of any provisions of the Contract Documents.

B. If one or more of the events identified in paragraph 15.02.A occur, OWNER may, after giving CONTRACTOR (and the surety, if any) seven days written notice, terminate the services of CONTRACTOR, exclude CONTRACTOR from the Site, and take possession of the Work and of all CONTRACTOR's tools, appliances, construction equipment, and machinery at the Site, and use the same to the full extent they could be used by CONTRACTOR (without liability to CONTRACTOR for trespass or conversion), incorporate in the Work all materials and equipment stored at the Site or for which OWNER has paid CONTRACTOR but which are stored elsewhere, and finish the Work as OWNER may deem expedient. In such case, CONTRACTOR shall not be entitled to receive any further payment until the Work is finished. If the unpaid balance of the Contract Price exceeds all claims, costs, losses, and damages (including but not limited to all fees and charges of engineers, architects, attorneys, and other professionals and all court or arbitration or other dispute resolution costs) sustained by OWNER arising out of or relating to completing the Work, such excess will be paid to CONTRACTOR. If such claims, costs, losses, and damages exceed such unpaid balance, CONTRACTOR shall pay the difference to OWNER. Such claims, costs, losses, and damages incurred by OWNER will be reviewed by ENGINEER as to their reasonableness and, when so approved by ENGINEER, incorporated in a Change Order. When exercising any rights or remedies under this paragraph OWNER shall not be required to obtain the lowest price for the Work performed.

C. Where CONTRACTOR's services have been so terminated by OWNER, the termination will not affect any rights or remedies of OWNER against CONTRACTOR then existing or which may thereafter accrue. Any retention or payment of moneys due CONTRACTOR by OWNER will not release CONTRACTOR from liability.

15.03 *OWNER May Terminate For Convenience*

A. Upon seven days written notice to CONTRACTOR and ENGINEER, OWNER may, without cause and without prejudice to any other right or remedy of OWNER, elect to terminate the Contract. In such case, CONTRACTOR shall be paid (without duplication of any items):

1. for completed and acceptable Work executed in accordance with the Contract Documents prior to the effective date of termination, including fair and reasonable sums for overhead and profit on such Work;

2. for expenses sustained prior to the effective date of termination in performing services and furnishing labor, materials, or equipment as required by the Contract Documents in connection with uncompleted Work, plus fair and reasonable sums for overhead and profit on such expenses;

3. for all claims, costs, losses, and damages (including but not limited to all fees and charges of engineers, architects, attorneys, and other professionals and all court or arbitration or other dispute resolution costs) incurred in settlement of terminated contracts with Subcontractors, Suppliers, and others; and

4. for reasonable expenses directly attributable to termination.

B. CONTRACTOR shall not be paid on account of loss of anticipated profits or revenue or other economic loss arising out of or resulting from such termination.

15.04 *CONTRACTOR May Stop Work or Terminate*

A. If, through no act or fault of CONTRACTOR, the Work is suspended for more than 90 consecutive days by OWNER or under an order of court or other public authority, or ENGINEER fails to act on any Application for Payment within 30 days after it is submitted, or OWNER fails for 30 days to pay CONTRACTOR any sum finally determined to be due, then CONTRACTOR may, upon

seven days written notice to OWNER and ENGINEER, and provided OWNER or ENGINEER do not remedy such suspension or failure within that time, terminate the Contract and recover from OWNER payment on the same terms as provided in paragraph 15.03. In lieu of terminating the Contract and without prejudice to any other right or remedy, if ENGINEER has failed to act on an Application for Payment within 30 days after it is submitted, or OWNER has failed for 30 days to pay CONTRACTOR any sum finally determined to be due, CONTRACTOR may, seven days after written notice to OWNER and ENGINEER, stop the Work until payment is made of all such amounts due CONTRACTOR, including interest thereon. The provisions of this paragraph 15.04 are not intended to preclude CONTRACTOR from making a Claim under paragraph 10.05 for an adjustment in Contract Price or Contract Times or otherwise for expenses or damage directly attributable to CONTRACTOR's stopping the Work as permitted by this paragraph.

ARTICLE 16 - DISPUTE RESOLUTION*

16.01 *Methods and Procedures*

A. Dispute resolution methods and procedures, if any, shall be as set forth in the Supplementary Conditions. If no method and procedure has been set forth, and subject to the provisions of paragraphs 9.09 and 10.05, OWNER and CONTRACTOR may exercise such rights or remedies as either may otherwise have under the Contract Documents or by Laws or Regulations in respect of any dispute.

ARTICLE 17 - MISCELLANEOUS*

17.01 *Giving Notice*

A. Whenever any provision of the Contract Documents requires the giving of written notice, it will be deemed to have been validly given if delivered in person to the individual or to a member of the firm or to an officer of the corporation for whom it is intended, or if delivered at or sent by registered or certified mail, postage prepaid, to the last business address known to the giver of the notice.

17.02 *Computation of Times*

A. When any period of time is referred to in the Contract Documents by days, it will be computed to

exclude the first and include the last day of such period. If the last day of any such period falls on a Saturday or Sunday or on a day made a legal holiday by the law of the applicable jurisdiction, such day will be omitted from the computation.

17.03 *Cumulative Remedies*

A. The duties and obligations imposed by these General Conditions and the rights and remedies available hereunder to the parties hereto are in addition to, and are not to be construed in any way as a limitation of, any rights and remedies available to any or all of them which are otherwise imposed or available by Laws or Regulations, by special warranty or guarantee, or by other provisions of the Contract Documents, and the provisions of this paragraph will be as effective as if repeated specifically in the Contract Documents in connection with each particular duty, obligation, right, and remedy to which they apply.

17.04 *Survival of Obligations*

A. All representations, indemnifications, warranties, and guarantees made in, required by, or given in accordance with the Contract Documents, as well as all continuing obligations indicated in the Contract Documents, will survive final payment, completion, and acceptance of the Work or termination or completion of the Agreement.

17.05 *Controlling Law*

A. This Contract is to be governed by the law of the state in which the Project is located.

PAGE LEFT INTENTIONALLY BLANK

SUPPLEMENTARY CONDITIONS

TABLE OF CONTENTS

Article Number	Title
1	DEFINITIONS AND TERMINOLOGY
2	PRELIMINARY MATTERS
3	CONTRACT DOCUMENTS: INTENT, AMENDING, REUSE
4	AVAILABILITY OF LANDS; SUBSUREACE AND PHYSICAL CONDITIONS; REFERENCE POINTS
5	BONDS AND INSURANCE
6	CONTRACTOR'S RESPONSIBILITIES
7	OWNER'S RESPONSIBILITIES
8	ENGINEER'S STATUS DURING CONSTRUCTION
9	COST OF THE WORK; CASH ALLOWANCES, UNIT PRICE WORK
10	CHANGE OF CONTRACT PRICE; CHANGE OF CONTRACT TIMES
11	TESTS AND INSPECTIONS; CORRECTION, REMOVAL OR ACCEPTANCE OF DEFECTIVE WORK
12	PAYMENTS TO CONTRACTOR AND COMPLETION
13	SUSPENSION OF WORK AND TERMINATION
14	MISCELLANEOUS

SUPPLEMENTARY CONDITIONS

AMENDMENTS TO GENERAL CONDITIONS

These Supplementary Conditions amend or supplement the Standard General Conditions of the Construction Contract (No. 1910-8, 1996 edition) and other provisions of the Contract Documents as indicated below. All provisions which are not so amended or supplemented remain in full force and effect.

ARTICLE I. DEFINITIONS AND TERMINOLOGY

Add the following language at the beginning of definition I.QI A.12 entitled "Contract Documents" in the General-Conditions:

"The Advertisement for Bids, Instructions to Bidders, State Regulations, ..."

Delete the words "The individual or entity named as such in the Agreement" in 1.01.A.19 and insert the following in their place:

"The individual or entity duly appointed by the Owner to undertake the duties and powers herein assigned to the Engineer, acting either directly or through duly appointed representatives."

Delete the words "and who is identified as such in the Supplementary Conditions" at the end of definition 1.01 A.20, entitled "ENGINEER'S Consultant."

Delete definition 1.01 A.41 entitled "Specifications" in the General Conditions in its entirety and insert the following in its place:

"Sections included under Division 1 through Division 16 of the Contract Documents:"

ARTICLE 2. PRELIMINARY MATTERS

SC-2.05

Delete paragraph 2.0SC of the General Conditions in its entirety and insert the following in its place:

"C. Evidence of Insurance: CONTRACTOR shall deliver to OWNER, with a copy to the ENGINEER, Certificates of Insurance within 10 days after receipt of the notice of the acceptance of bid (and other evidence requested by OWNER) which CONTRACTOR is required to purchase and maintain in accordance with the requirements of Article 5."

ARTICLE 3. CONTRACT DOCUMENTS: INTENT, AMENDING, REUSE
SC-3.0

Add the following sentence at the end of Paragraph 3.01A of the General Conditions:

"...by all. Each and every provision of law and clause required by law to be inserted in these Contract Documents shall be deemed to be inserted herein, and they shall be read and enforced as though it were included herein, and if through mistake or otherwise, any such provision is not inserted, or if not correctly inserted, then upon the application of either party, the Contract Documents shall forthwith be physically amended to make such insertion."

ARTICLE 4. AVAILABILITY OF LANDS; SUBSURFACE AND PHYSICAL CONDITIONS;
REFERENCE POINTS

SC-4.02

Delete the term "Supplementary Conditions" of paragraph 4.02 A of the General Conditions and replace it with "Contract Documents".

SC-4.04

Change "of" to "or" on line 6 of paragraph 4.04 B.2 of the General Conditions. Delete the following words from lines 8 and 9 of paragraph 4.04 B.2 of the General Conditions:

"...Or not shown or indicated with reasonable accuracy..."

SC-4.05

Add a new paragraph immediately after paragraph 4.05A of the General Conditions which is to read as follows:

B. ENGINEER may check the lines elevations and reference marks set by CONTRACTOR, and CONTRACTOR shall correct any errors disclosed by such check. Such a check shall not be considered as approval of CONTRACTOR'S work and shall not relieve CONTRACTOR of the responsibility for construction of the entire Work in accordance with the Contract Documents. CONTRACTOR shall furnish personnel to assist ENGINEER in checking lines and grades."

SC-4.06

Delete the term Supplementary Conditions in paragraph 4.06A of the General Conditions and replace it with "Contract Documents".

ARTICLE 5. BOND AND INSURANCE

NOTICE TO CONTRACTOR:

1. Proof of Insurance coverage shall be furnished to the OWNER in accordance with the schedule for submittal of Bonds and Agreements.
2. Additionally refer to Article 2. PRELIMINARY MATTERS, Paragraph SC-2.05.C

SC-5.01

Insert these sentences following SC-5.01.A: The Surety Company providing the bonds shall have a rating of A or better within the Best Key Rating Guide and be licensed by the Massachusetts Division of Insurance. The contractor shall pay the premiums for such Bonds.

SC-5.03

Delete the second sentence following SC-5.03.A: of the General Conditions, which beings "OWNER shall deliver to..."

SC-5.04

The limits of liability for the insurance required by paragraph 5.04A of the General Conditions shall provide coverage for not less than the following amounts or greater where required by law:

5.4 A.1 and 5.04 A.2 Worker's Compensation

(1) Worker's Compensation	Statutory Requirements
(2) Coverage B - Employer's Liability	\$100,000/\$500,000/\$100,000

5.04 A.3, 5.04 A.4, and 5.04 A.5 Commercial General Liability Limits shall include Coverage for... independent Contractors, Personal Injury, Owners and Contractors Protective Liability, Explosion, Underground and Collapse, Broad Form Property Damage, Blanket Contractual Liability per locations/project endorsement.

Commercial General Liability	\$1,000,000/\$2,000,000
Products/completed Operations	\$2,000,000 Aggregate

5.4 A.6 Automobile Liability for owned, hired and non-owned vehicles:

(1) Bodily injury:	\$1,000,000/\$1,000,000	Each person
	\$1,000,000/\$1,000,000	Each accident
(2) Property damage	\$1,000,000	Each occurrence

The following indemnity agreement: shall be made part of this contract:

1.To the fullest extent permitted by law, Contractor(s) hereby acknowledges and agrees that it shall indemnify, hold harmless and defend the Engineer, the Owner, the Engineer and any of their officers, directors, employees, agents, affiliates, subsidiaries and partners from and against all-claims, damages, losses and expenses, including but not limited to, attorney's fees, arising out of or resulting from the performance of the contractor's work under this contract, provided that any such claim, damage, loss or expense (1) is attributable to bodily injury to or destruction of tangible property (other than to the work itself) including loss of use resulting therefrom, and (2) is (CAUSED) in whole or in part by any

negligent acts omissions of the contractor, its employees, agents or contractors or anyone directly or indirectly employed by any of them, or anyone whose acts any of them may be liable.

2. The Contractor hereby acknowledges its obligation under the foregoing paragraph to indemnify the Engineer and Owner against judgments suffered because of the contractor's work and to assume the cost of defending the Engineer and Owner against claims as described in the foregoing paragraph.

A. Engineer and Owner shall be named as Additional Insured on contractors General Liability and Umbrella Liability Contractors.

The Contractual Liability required by paragraph s.04n.4 of the General Conditions shall provide coverage for not less than the following amounts:

- | | |
|--|---|
| (1) Bodily injury: | \$1,000,000 Each occurrence
\$1,000,000 Annual aggregate |
| (2).Property damage, including explosion, collapse and underground coverage: | \$1,000,000 Each occurrence
\$1,000,000 Annual aggregate |

SC-5.04

Add two new paragraphs immediately after paragraph-5.04B of the General Conditions, which are to read as follows:

"C. The CONTRACTOR shall also provide:

1. CONTRACTOR shall, as a minimum, purchase and maintain excess liability insurance in the umbrella form with a combined single limit of not less than \$5,000,000 per claim and in the aggregate. Evidence of such excess liability shall be delivered to OWNER in accordance with paragraph 2.0SC in the form of a certificate indicating the policy numbers and limits of liability of all underlying insurance.

A. General Liability, Workers' Compensation, Automobile Liability and Umbrella Liability Policies will contain waivers of subrogation in favor of the Engineer and Owner.

2. If the aggregate limits of liability indicated in CONTRACTOR' insurance provided in accordance with paragraphs 5.03 and 5.04 are not sufficient to cover all claims for damages arising from his operations under this Contract and from any other work performed by him or if policies of insurance do not provide that the aggregate limits of liability for bodily injury and property damage apply to each contract or project separately, CONTRACTOR shall have such policies amended so that the aggregate limits of liability required by this Contract will be available to cover all claims for damages due to operations under this Contract."

SC-5.05

Delete paragraph 5 .05 of the General Conditions in its entirety.

SC-5.06

Delete Paragraph 5.06 A of the General Conditions in its entirety and insert the following in its place:

"A. CONTRACTOR shall purchase and maintain, until final payment, property insurance upon the Work at the site in an amount equal to the total bid price for the completed construction. This insurance shall include the interests of OWNER, CONTRACTOR, Subcontractors, ENGINEER and ENGINEERS consultants in the Work, shall insure against the perils of fire and extended coverage, shall include "all risk" insurance for physical loss and damage including theft, vandalism and malicious mischief, collapse and water damage, and shall include damages, losses and expenses rising out of or resulting from any insured loss or incurred in the repair or replacement of any insured property (including but not limited to fees and charges of engineers, architects, attorneys and other professionals). This insurance shall be provided on the completed value form.' If not covered under the "all risk" insurance or otherwise provided in these Supplementary Conditions, CONTRACTOR shall purchase and maintain similar property insurance on portions of the Work stored on and off the site or in transit when such portions of the Work are to be included in an Application for Payment." A \$20,000 deductible shall be acceptable. Any other deductible amount shall be approved in advance by the OWNER and any deductible amount shall be borne by the CONTRACTOR.

Delete paragraph 5.068 of the General Conditions in its entirety.

Delete Paragraph 5.06C of the General Conditions in its entirety and insert the following in its place:

"C. All the policies of insurance (or the certificates or other evidence thereof) required to be purchased and maintained by CONTRACTOR in accordance with paragraphs 5.06 will contain a provision or endorsement that the coverage afforded will not be canceled or materially changed or renewal refused until at least thirty days' prior written notice has been given to OWNER by certified mail and will contain waiver provisions in accordance with paragraph 5.078. The words "**Endeavor** to" shall be struck from the Certificate Of Insurance in the Cancellation Statement"

Delete paragraph 5.06D of the General Conditions in its entirety.

Delete paragraph 5.06E of the General Conditions in its entirety.

SC-5.07

Amend the last sentence of paragraph 5.07A of the General Conditions by striking out the words "held by OWNER as trustee or." As so amended, paragraph 5.07A remains in effect.

SC-5.08

Delete paragraph 5.08A of the General Conditions in its entirety.

Delete paragraph 5.0813 of the General Conditions in its entirety.

SC-5.09

Delete paragraph 5.09A of the General Conditions in its entirety and insert the following in its place:

"A. If OWNER has any objection to the coverage afforded by or other provisions of the insurance required to be purchased and maintained by CONTRACTOR in accordance with this Article 5 on the basis of its not complying with the Contract Documents, OWNER will notify CONTRACTOR in writing thereof within thirty days of the date of delivery of such certificates to OWNER in accordance with paragraph 2.0SC. CONTRACTOR will provide such additional information in respect of insurance provided by him as OWNER may reasonably request."

ARTICLE 6. CONTRACTOR'S RESPONSIBILITIES

SC-6.01

Delete paragraph 6.01B of the General Conditions in its entirety and replace with the following:

"B. At the site of the Work the CONTRACTOR shall employ a full-time construction superintendent or foreman who shall have full authority to act for the CONTRACTOR. It is understood that such representative shall be acceptable to the ENGINEER and shall be one who will be continued in the capacity for the particular job involved unless the representative ceases to be on the CONTRACTOR'S payroll. If at any time during the Work the representative is deemed by the ENGINEER to be no longer acceptable, the representative shall be promptly replaced by the CONTRACTOR. All communications to the superintendent shall be as binding as if given to the CONTRACTOR."

SC-6.04

Add the following paragraph after paragraph 6.04 A.2 of the General Conditions: -

"B. The CONTRACTOR's resident superintendent shall attend monthly progress meetings at the site of the work with the ENGINEER and others as appropriate to review schedule status and such other pertinent subjects as may be listed on the agenda by the ENGINEER."

SC-6.17

In paragraph 6.17 E.1 of the General Conditions, delete the word "timely" from the first line.

SC-6.20

Delete paragraph 6.20A of the General Conditions in its entirety and replace with the following:

"A. To the fullest extent permitted by law, the CONTRACTOR shall indemnify and hold harmless the OWNER, the ENGINEER, ENGINEER'S consultants, and their agents and employees from and against all claims, damages, losses and expenses, including but not limited to attorneys fees, arising out of or resulting from the performance of the Work, provided that such claim, damage, loss or expense is attributable to bodily injury, sickness,

disease or death, or to injury to or destruction of tangible property (other than the Work itself) including loss of use resulting therefrom, but only to the extent caused in whole or in part by acts or omissions of the CONTRACTOR, a subcontractor, anyone directly or indirectly employed by them or anyone for whose acts they may be liable, regardless of whether or not such claim, damage, loss or expense is caused in part by a party indemnified hereunder. Such obligation shall apply to any such claims, damages, losses and expenses which arise and/or are incurred by any person or entity either during the performance of the Work and/or alter completion of construction. Nothing in this paragraph shall be construed to negate, abridge, or reduce other rights or obligations of indemnity or contribution which would otherwise exist as to a party or person indemnified hereunder. CONTRACTOR hereby assumes the responsibility and liability for injury to or death of any and all persons, including the. CONTRACTOR's employees, and for any and all damage to property caused by, resulting from, or arising out of any act, omission or neglect on the part of the CONTRACTOR, or of any Subcontractor or of anyone directly or indirectly employed by any of them or of anyone for whose acts, any of them may be liable."

Delete paragraph 6.20C of the General Conditions in its entirety.

ARTICLE 8. OWNER'S RESPONSIBILITIES

SC-8.06

Delete paragraph 8.06A of the General Conditions in its entirety.

ARTICLE 9. ENGINEER'S STATUS DURING CONSTRUCTION

SC-9.01

Add a new paragraph 9.0113 after paragraph 9.01A of the General Conditions, which is to read as follows:

"B. Nothing contained in the Contract Documents shall be construed to create a contractual relationship of any kind (1) between the ENGINEER and CONTRACTOR, (2) between the OWNER and a Subcontractor or Subcontractors, or (3) between any person or entities other than the OWNER and CONTRACTOR. The ENGINEER shall, however, be entitled to performance and enforcement of obligations under the CONTRACT DOCUMENTS intended to facilitate performance of the ENGINEERS duties."

ARTICLE 11. COST OF THE WORK; CASH ALLOWANCES; UNIT PRICE WORK

Delete Article 11 of the General Conditions in its entirety and replace with the following:

"A. The unit price of an item of Unit Price work shall be subject to reevaluation and adjustment under the following conditions:

(1) If the total extended bid price [Estimated Quantity times the Bid Unit Price] of a particular item of Unit Price Work amounts to 5 percent or more of the Original Contract Price and the variation in the quantity of the particular item of Unit Price Work performed by CONTRACTOR differs by more than 15 percent from the estimated quantity of such item indicated in the Agreement;
and

(2) If there is no corresponding adjustment with respect to any other item of work; and

(3) If CONTRACTOR believes that CONTRACTOR has incurred additional expense as a result thereof, CONTRACTOR may make a claim for an adjustment in the Contract Price in accordance with Article 11- if the parties are unable to agree as to the effect of any such variations in the quantity of Unit Price Work performed. If OWNER believes that the quantity variation entitles OWNER to an adjustment in the unit price, OWNER shall be entitled to an adjustment in the unit price in an amount determined by the ENGINEER. ENGINEER shall not be liable in connection with any determination relating to adjustments which is rendered in good faith."

ARTICLE 12. CHANGE OF CONTRACT PRICE; CHANGE OF CONTRACT TIMES

SC-12.06

Add the following new paragraphs after paragraph 12.06 of the General Conditions:

"12.07 Liquidated Damages:

A. If the CONTRACTOR shall neglect, fail or refuse to complete the work within the time herein specified, or any proper extension thereof granted by the OWNER, then the CONTRACTOR does hereby agree, as a part consideration for the awarding of this Contract, to pay to the OWNER the amount specified in the Contract, not as a penalty but as liquidated damages for such breach of contract as hereinafter set forth, for each and every calendar day that the Contract shall be in default after the time stipulated in the Contract for completing the work. Such damages may be retained from time to time by the OWNER from progress payments or any amounts owing to the CONTRACTOR, or otherwise collected.

B. The said amount is fixed and agreed upon by and between the CONTRACTOR and the OWNER because of the impracticability and extreme difficulty of fixing and ascertaining the actual damages the OWNER would in such event sustain, and said amount is agreed to be the amount of damages which the OWNER would sustain and said amount shall be retained from time to time by the OWNER from current periodical estimates.

C. It is further agreed that time is of the essence of each and every portion of this Contract and of the specifications wherein as definite and certain length of times is fixed for the performance of any act whatsoever; and where under the Contract an additional time is allowed for the completion of any work, the new time limit fixed by such extension shall be of the essence of this Contract. Provided that the CONTRACTOR shall not be charged with liquidated damages of any excess cost when the OWNER determines that the CONTRACTOR is without fault and the CONTRACTOR'S reasons for the time extension are acceptable to the OWNER; Provided, further, that the CONTRACTOR shall not be charged with liquidated damages or any excess cost when the delay in completion of the work is due:

1) to any preference, priority or allocation order duly issued by the Government;

2) to unforeseeable cause beyond the control and without the fault or negligence of the CONTRACTOR, including, but not restricted to, acts of God, or of the public enemy, acts of the OWNER, acts of another CONTRACTOR in the performance of a contract with the OWNER, fires, floods, epidemics, quarantine restrictions, strikes, freight embargoes, and severe weather; and

3) to any delays of subcontractors or suppliers occasioned by any of the causes specified in subsections C(1) and C(2) above;

D. Provided, further, that the CONTRACTOR shall, within ten (10) days from the beginning of such delay, unless the OWNER shall grant a further period of time prior to the date of final settlement of the Contract, notify the OWNER, in writing, of the causes of the delay, who shall ascertain the facts and extent of the delay and notify the CONTRACTOR within a reasonable time of its decision in the matter."

ARTICLE 13. TESTS AND INSPECTIONS; CORRECTION, REMOVAL OR ACCEPTANCE OF DEFECTIVE WORK

SC-13.07

Delete paragraph 3.07A of the General Conditions and insert the following in its place:

"A. If within one year after the date of Substantial Completion or such longer period of time as may be prescribed by Laws or Regulations or by the terms of any applicable special guarantee required by the Contract Documents or by any specific provision of the Contract Documents, any work is found to be defective, CONTRACTOR shall promptly, without cost to OWNER and in accordance with OWNER's written instructions: (i) correct such defective work, or, if it has been rejected by OWNER, remove it from the site and replace it with work that is not defective, and (ii) satisfactorily correct or remove and replace any damage to other work or the work of others therefrom. If CONTRACTOR does not begin the repairs ten (10) days of receipt of written notification and promptly comply with the terms of OWNER's written instructions, or in an emergency when delay would cause serious risk, loss or damage, OWNER may have the defective work corrected or the rejected work removed and replaced, and all claims, costs, losses and damages caused by or resulting from such removal and replacement (including but not limited to all costs of repair or replacement of work of others) will be paid by CONTRACTOR."

SC-13.09

Revise paragraph 13.09A of the General Conditions

A. Delete the word "seven" and replace it with the word "ten" so that it reads "after ten days written notice to CONTRACTOR."

ARTICLE 14. PAYMENTS TO CONTRACTOR AND COMPLETION

SC-14.02

Delete paragraph 14.02A.3 and insert the following in its place:

"3. Retainage with respect to progress payments will be five percent or, if stipulated, the maximum allowed by law."

Add Paragraph 4. to read as follows:

"4. The CONTRACTOR shall submit Weekly Payroll Records Report and Statement of

Compliance verifying compliance with the Minimum Prevailing Wage Law, MGL ch. 149, Sections 26-27H. "These Statements of Compliance shall be submitted as a condition of payment for work performed during the period the reports apply."

SC-14.03

Delete paragraph 14.03A in its entirety and insert the following in its place:

"A CONTRACTOR warrants and guarantees that title to all work, material and equipment covered by any Application for Payment, whether incorporated in the Project or not, will pass to OWNER no later than at the time of Application for Payment free and clear of all liens. CONTRACTOR shall provide written transfer of title and a certified paid invoice provided by the supplier."

ARTICLE 15. SUSPENSION OF WORK AND TERMINATION

SC-15.02

Add a new paragraph immediately after paragraph 15.02 AA of the General Conditions which is to read as follows:

"5. If the Work to be done under this Contract shall be abandoned, or if this Contract or any part thereof shall be sublet, without the previous written consent of OWNER, or if the contract or any claim thereunder shall be assigned by CONTRACTOR otherwise than as herein specified;"

ARTICLE 17. MISCELLANEOUS

SC-17.06, 17.07, 17.08, 17.09

Add the following new paragraphs after paragraph 17.05 of the General Conditions:

"17.06 Assignment:

A. The CONTRACTOR shall not assign the whole or any part of this Contract or any moneys due or to become due hereunder until thirty (30) days prior notice in writing has been given to the OWNER of the intention to assign, which notice shall state the identity and address of the prospective assignee. No assignment shall be made without the OWNER's prior written consent. Such consent shall not be unreasonably withheld. In case the CONTRACTOR assigns all or any part of the moneys due or to become due under this Contract, the instrument of assignment shall contain a clause substantially to the effect that it is agreed that the right of the assignee in and to any moneys due or to become due to the CONTRACTOR shall be subject to prior claims of all persons, firms and corporations of services rendered or materials supplied for the performance of the work called for in this Contract."

17.7 Liability

It is understood and agreed that members of the OWNER or the ENGINEER' or any agent or employees of the OWNER signing this Agreement shall not be personally liable hereunder for any action incurred in connection with this Agreement.

17.8 State Statutes and Regulations

See Superseding Changes To General & Supplementary Conditions 12/29/04 for further modifications of the General Conditions due to state statutes and regulations.

17.9 Severability

If any provision of this Agreement shall be invalid or unenforceable to any extent or in any application, then the remainder of this Agreement and of such terms and conditions, except to such extent or in such application, shall not be affected thereby, and each and every term and condition of this Agreement shall be valid and enforced to the fullest extent and in the broadest application permitted by law."

END OF SECTION

**STATE STATUTES AND REGULATIONS
COMMONWEALTH OF MASSACHUSETTS**

A. REVISIONS TO GENERAL CONDITIONS

1. Definitions
2. Subsurface Conditions Found Different
3. Subcontracting
4. Permits
5. Contractor Records
6. Massachusetts Sales and Use Tax I
7. Clarifications and Interpretations
8. Change of Contract Price
9. Payments
10. Suspension of Work and Termination
11. Labor Classification and Minimum Wage Rates

B. OTHER REGULATORY REQUIREMENTS

1. Working Hours
2. DEP Community Sound Level Criteria

ATTACHMENT A – Wage Rates

ATTACHMENT B

Excerpts from Chapter 149 and Chapter 30 of the Massachusetts General Law

ATTACHMENT C - (not used on this project)

Special Provisions for Minority/Women Business Enterprises and the Commonwealth of Massachusetts Supplemental Equal Employment Opportunity Anti-Discrimination and Affirmative Action Program.

ATTACHMENT D--

Change Orders

A. REVISIONS TO GENERAL CONDITIONS:

1. Definitions

The term "AWARDING AUTHORITY," as used herein, shall be considered to be synonymous with the term "OWNER," described in definition 1.01 A.30.

Delete definition 1.01 A.43 entitled "Substantial Completion" in the General Conditions in its entirety and insert the following in its place:

"Substantial Completion shall be interpreted in accordance with Massachusetts General Law Chapter 30, Section 39G or -39K as appropriate."

2. Subsurface Conditions Found Different

Add the following sentence to the end of paragraph 4.03A of the General Conditions:

"...to do so. Adjustments resulting from subsurface or latent physical conditions will be in accordance with Massachusetts General Law Chapter 30, Section 39N."

3. Subcontracting

Add the following language at the end of paragraph 6.06F of the General Conditions:

"Except as required otherwise by Massachusetts General Law Chapter 149, Section 44F, for Work governed by Chapter 149, sections 44A through 44H."

4. Permits

Delete paragraph 6.08A of the General Conditions in its entirety and insert the following in its place:

"A. The AWARDING AUTHORITY shall be responsible for identifying and obtaining all federal, state, and local permits required by the nature and location of construction, including but not limited to railroad permits, building construction permits, and permits for street and highway cuts and openings. CONTRACTOR shall be responsible for obtaining all permits required of his equipment, work force, or particular operations (such as blasting) in the performance of the Work and not otherwise specified to be obtained by the AWARDING AUTHORITY. These permit fees shall be paid by CONTRACTOR. CONTRACTOR shall pay all governmental charges and inspection fees necessary for the prosecution of the Work, which are applicable at the time of opening of bids, or, if there are no Bids, on the Effective Date of the Agreement."

5. Contractor Records

Add a new paragraph immediately after paragraph 6.09C of the General Conditions, which is to read as follows:

"D. The CONTRACTOR shall comply with all applicable provisions Chapter 30, Section 39R of the Massachusetts General Laws Regarding, CONTRACTOR'S records."

6. Massachusetts Sales and Use Tax

Add the following paragraph after paragraph 6.10A of the General Conditions:

"B. The material and supplies to be used by the CONTRACTOR in the Work of this Contract are exempt from the Sales and Use Tax of the Commonwealth of Massachusetts. The AWARDING AUTHORITY tax exemption certificate number will be furnished to the CONTRACTOR."

7. Clarifications and Interpretations

Add the following language at the end of paragraph 9.04A of the General Conditions:

"The ENGINEER'S interpretation will be made in accordance with the requirements of Massachusetts General Law Chapter 30, Section 39P."

8. Change of Contract Price

Delete paragraphs 11.01, 11.02, and 12.01 of the General Conditions, having to do with Change of Contract Price. Changes in contract price will be governed by the section called "Change Orders" in Attachment D, Section XXX and Article 11 in the Supplementary Conditions.

9. Payments

Delete paragraph 12.028.1 of the General Conditions, in its entirety and insert the following in its place:

"1. Progress Payments will be made in accordance with the Massachusetts General Law Chapter 30, Section 39G or 39K, as applicable."

Add the following new paragraph following paragraph 14.02C.1 of the General Conditions:

"2. The CONTRACTOR shall make payments to Subcontractors in accordance with the requirements of Massachusetts General Law Chapter 30, Section 39F."

Delete paragraph 14.07B of the General Conditions in its entirety and insert the following in its place:

"1. If, on the basis of the ENGINEER's observation of the Work during construction and final inspection and, upon the ENGINEER's review of the final Application for Payment and accompanying documentation, the ENGINEER is satisfied that the Work has been completed and that the CONTRACTOR's other obligations under the Contract Documents have been fulfilled, the ENGINEER will indicate in writing his recommendation of payment and present the Application to the AWARDING AUTHORITY for payment. Thereupon the ENGINEER will give written notice to the AWARDING AUTHORITY and the CONTRACTOR that the Work is acceptable subject to the provisions of paragraph 14.15. Otherwise, the ENGINEER will return the Application to CONTRACTOR, indicating in writing the reasons for refusing to recommend final payment. In such case the CONTRACTOR shall make the

necessary corrections and resubmit the Application. If the Application and accompanying documentation are appropriate as to form and substance, the AWARDING AUTHORITY shall in accordance with the applicable Massachusetts General Law, pay the CONTRACTOR the amount recommended by the ENGINEER."

10. Suspension of Work and Termination

Delete paragraph 15.01A of the General Conditions in its entirety and insert the following in its place:

"A. The AWARDING AUTHORITY may order, at any time and without cause, the CONTRACTOR to suspend or delay the Work in accordance with Massachusetts General Law Chapter 30, Section 39-0."

11. Labor Classifications and Minimum Wage Rates

Add the following paragraphs under the heading "Wage Rates" after paragraph 17.10 of the Supplementary Conditions:

"17.11 Wage Rates

- A. Minimum wage rates as determined by the Commissioner of the Department of Labor and Industries under the provisions of Massachusetts General Laws Chapter 149, Sections 26-270 apply to this project. A copy of the wage schedule is included in the front end of the specifications under Federal Minimum Wage Rates. If, after the Notice of Award, it becomes necessary to employ any person in a trade or occupation not classified in the wage determinations, such person shall be paid at not less than such rates as shall be determined by the Commissioner. Such approved minimum rate shall be retro- active to the time of the initial employment of such person in such trade or occupation. The CONTRACTOR shall notify the AWARDING AUTHORITY of its intention to employ persons in trades or occupations not classified in the wage determinations as soon as possible in order to allow sufficient time for the AWARDING AUTHORITY to obtain approved rates for such trades or occupations.
- B. The schedule of wages referred to above are minimum rates only, and the AWARDING AUTHORITY will not consider any claims for additional compensation made by CONTRACTOR because of payment by the CONTRACTOR of any wage rate in excess of the applicable rate contained in the Contract.
- C. The said schedule of wages shall continue to be the minimum rates to be paid during the life of this Agreement and a legible copy of said schedule shall be kept posted in a conspicuous place at the site of the Work.
- D. CONTRACTOR and subcontractors shall submit a copy of weekly payroll records to the AWARDING AUTHORITY and the AWARDING AUTHORITY shall retain the records of a minimum of three years."

B. OTHER REGULATORY REQUIREMENTS:

1. Working Hours

No laborer, workman, mechanic, foreman, or inspector, working within the Commonwealth, in the employ of the CONTRACTOR, subcontractor, or other person doing or contracting to do the whole or a part of the work contemplated by this contract, shall be required or permitted to work more than eight hours in any one day or more than forty-eight hours in any one week, or more than six days in any one week, except in cases of emergency.

2. DEP Community sound Level Criteria

The Community Sound Level Criteria as established by the Commonwealth of Massachusetts Department of Environmental Protection (DEP) must be conformed to prior to the AWARDING AUTHORITY's acceptance of the structure. The following sound level criteria must be met at the construction site:

- A. The increase in the broad band noise level shall not be in excess of ten (10) dB(A) above ambient at the station boundary. The ambient level is defined as the A-weighted noise level that is exceeded ninety (90) percent of the time measured during the period in question.
- B. The primary noise source(s) shall not produce a puretone condition. Puretone is any given octave band center frequency that exceeds the two adjacent center frequencies by three (3) or more decibels.

END OF SECTION

**SUPERSEDING CHANGES TO
GENERAL AND SUPPLEMENTARY CONDITIONS**

1. GENERAL CONDITIONS

2.06A - insert at end: Said conference shall be scheduled and arranged by the Contractor. I

4.01B - delete

4.06G - delete

5.07B - delete

6.17E - restore the word "timely" in the first line. Delete the word "only" from the 5" line. Where "only" has been deleted, insert "to determine their general conformance with the contract documents, in accordance with good and accepted engineering practices, and".

8.02A - delete "to whom contractor makes no reasonable objection".

9.02A - Insert, after "Work" in the 6" line, "While construction is active at the project, said visits and inspections will take place at least once per week."

12.06 - delete subparts A and B, and replace with the following: "The Contractor hereby agrees that the Contractor shall have no claim for damages of any kind against the Owner or the Engineer on account of any delay in the commencement of the Work and/or any delay in, or suspension of any portion of the Work, whether such delay is caused by the Owner, the Engineer, or otherwise. The Contractor acknowledges that the Contractor's sole remedy for any such delay and/or suspension will be an extension of time as provided in these general conditions.

No claims shall be allowed on account of the failure of the Engineer to furnish Drawings, specifications or instructions or to return Shop Drawings or Samples until the expiration of the applicable time period referenced in Mass. Gen. L. c. 30, §39P, and not then unless such claim be reasonable.

No extension of time shall be granted because of seasonable or abnormal variations in temperature, humidity or precipitation, which conditions shall be wholly at the risk of the Contract, whether occurring within the time originally scheduled for completion, or within any period of extension granted. There shall be no increase in the Contract Sum on account of any additional costs or operations or conditions resulting therefrom.

14.02C - change "Ten" to "Twenty-One"

14.07A(3) - delete the first three lines through the word "Owner,". In the third line, after Contractor, substitute "shall" for "may". In the fourth line, after the word "full" insert "on behalf of both Contractor and all of its Subcontractors,".

14.09A(1) - delete -

15.03B - add after "termination" ", with respect to this project or any other project of the Contractor."

Add "15.03C. If this Contract is terminated by Owner with or without cause, and regardless of whether said termination is rightful or wrongful, in no event shall the Contractor be paid a sum which, together with prior payments to Contractor, exceeds the sum payable to Contractor under the Agreement (Section 00520), as adjusted by any agreed change orders.

II. SUPPLEMENTARY CONDITIONS

Article V - Bonds and Insurance

Employer's liability coverage must be \$2 million per accident, \$2 million disease limits, and \$2 million per employee disease limits.

General liability insurance limits must be \$5 million aggregate, \$2 million dollars' products/completed operations aggregate; \$2 million personal injury and advertising; and \$2 million per occurrence.

The contractual liability insurance coverage must have limits corresponding to the foregoing. At 5.04A.6, the following changes should be made to paragraph I of the indemnity clause: four lines from the bottom, the parenthesis should be removed from the word "CAUSED" and the word "CAUSED" should be changed to lower-case (caused). Also, in the last line of said clause, insert the word "for" after the word "anyone."

At SC-5.04C 1 - insert the following sentence at the end: "The Contractor's excess liability insurance coverage must follow from with its underlying liability coverages."

SC-6.20A - insert the word "defend" after the word "shall" in the first line.

SC-14.02A.3 - insert the following sentence at the end: "Retainage for the entire project will be withheld until substantial completion of the entire project, at which time retainage shall be accounted for, subject to all of the other terms and conditions of payment at the time of substantial completion.

Add the following Article SC-18.

SC-I 8 Arbitration - J

18.1 Controversies and Claims Subject to Arbitration. Any Claim arising out of or related to the Contract, or the breach thereof, except claims relating to aesthetic effect, shall be settled by arbitration, subject to the provisions of Subparagraph 18.7. Arbitration will be conducted in accordance with the Construction Industry Arbitration Rules of the American Arbitration Association and judgment upon the award rendered by the Arbitrator or Arbitrators may be entered in any Court having jurisdiction thereof. In any such arbitration in which the amount stated in the demand is \$100,000 or less, a single arbitrator shall be appointed in accordance with the procedures set forth in the American Arbitration Association Construction Industry Arbitration Rules. In any such arbitration in which the amount stated in the demand is in excess of \$100,000, a panel of three arbitrators shall be appointed in accordance with the procedures set forth in the American Arbitration

Association Construction Industry Arbitration Rules. The parties may agree to use any arbitration service. In the absence of such agreement, the American Arbitration Association shall be utilized.

18.2 Rules For Arbitration. If the neutral arbitrator is appointed by the American Arbitration Association, the said Association shall administer the arbitration and its Construction Industry Arbitration Rules shall govern all aspects of the proceeding including the enforcement of any award. If the neutral arbitrator is not appointed by the American Arbitration Association, then the panel of arbitrators shall act as the administrator of the arbitration but the Construction Industry Arbitration Rules of the Association shall nonetheless govern all aspects of the proceeding, including the enforcement of any award. The arbitration panel shall have all the powers and duties conferred on the Association pursuant to said rules.

In addition, the following rules shall govern the selection of arbitrators and the proceedings:

18.2.1 Neither party may appoint as arbitrator an employee or an owner of that party, nor the parent, spouse or child of an employee or owner of that party.

18.2.2 After the neutral arbitrator has been appointed, neither party may engage in ex parte communication with the arbitrator appointed by that party.

18.2.3 Contract Performance During Arbitration. During arbitration proceedings, the Owner and Contractor shall otherwise continue their performances hereunder.

18.3 When a written decision of the Engineer states that the decision is final, any demand for arbitration of the matter covered by such decision must be made within two months after substantial completion of the project, as determined by the Engineer in accordance with the provisions hereof. The failure to demand arbitration within said two month period will result in the Engineer's decision becoming final and binding upon the Owner and the Contractor.

18.4 A Demand for arbitration shall be made with the time limits specified in Subparagraph 18.3, and in no event shall be made after the date when the institution of legal or equitable proceedings based on such Claim would be barred by the applicable statute of limitations.

18.5 Claims and Timely Assertion of Claims. A party who files a notice of demand for arbitration must assert in the demand all Claims then known to that party on which arbitration is permitted to be demanded. When a party fails to include a claim through oversight, inadvertence or excusable neglect, or when a Claim has matured or been acquired subsequently, the arbitrator or arbitrators may permit amendment.

18.6 Judgment on Final Award. The award rendered by the arbitrator or arbitrators shall be final, and the judgment may be entered upon it in accordance with applicable law in any court having jurisdiction thereof.

18.7 Notwithstanding any provision contained in this Paragraph 18 or elsewhere in the Contract Documents, the Owner reserves the following right in connection with claims and disputes between the Owner and Contractor:

1. the right to institute the legal action against the Contractor in any court of competent jurisdiction in-lieu of demanding arbitration pursuant to this paragraph 18, in which case the dispute or disputes which are the subject of such action shall be decided by such court, and not by arbitration.

2. the right to obtain from any court of competent jurisdiction a stay of any arbitration instituted by the Contractor, provided that the application for such stay is made before the appointment of the neutral arbitrator in such arbitration, in which case the dispute or disputes which are the subject of such arbitration shall be decided by such court, and not by arbitration;

3. the right to require the Contractor to join as a party in any arbitration between the Owner and Architect relating to the Project in which case the Contractor agrees to be bound by that decision of the arbitrator arbitrators in such arbitration.

In case the Owner elects to proceed in accordance with 18.7.1 or 18.7.2 above, the word "litigation", shall be deemed to replace the word "arbitration" wherever the latter word appears in the Contract Documents.

SC-19 MBE and WBE participation

The Contractor shall comply with the provision of G.L.c. 7 40N, and any associated regulations effective during the time of the project, relative to the participation of minority and women-owned businesses in connection with the project. At present, the current participation goals are 7.4% MBE and 4% WBE.

END OF SECTION

INSURANCE REQUIREMENTS

1. GENERAL

A. This section specifies the Owner's requirements for insurance and relates to the General Conditions of the Contract for Construction and Supplementary Conditions of the Contract for Construction.

B. Provisions of the General Conditions of the Contract for Construction and Supplementary General Conditions of the Contract for Construction, which are not modified by the following insurance Requirements, remain in full effect.

2. INSURANCE REQUIREMENTS

A. Insurance Limits: The insurance required should be written for not less than the limits of liability required by law or the following limits, whichever is greater: State and federal Workmen's Compensation Statutory Benefits required by union contract as required.

GENERAL LIABILITY*

General Liability- Bodily Injury and Property Damage Each Occurrence	\$1,000,000.00
General Liability — Bodily Injury and Property Damage Aggregate	\$2,000,000.00

General Liability shall include coverage for the following:

- Comprehensive form
- Premise/Operations Liability
- Explosion, Collapse and Underground (XCU). Products/Completed Operations (aggregate limit \$2,000,000.00) Contractual Liability
- Independent Contractors Broad
- Form Property Damage
- Personal Injury Including Libel and Slander Coverage Broad
- Form CGL Endorsement

AUTOMOBILE LIABILITY**

Comp. Automobile Liability** Bodily Injury and Property Damage Per Accident	\$1,000,000.00
---	----------------

**Provide coverage for All Owned, Non-Owned, and Hired vehicles.

EXCESS LIABILITY – Umbrella Form

Each occurrence	\$5,000,000.00
Aggregate	\$5,000,000.00

B. Exclusions: The Owner's property insurance shall not cover tools, equipment, shoring, staging, forms, temporary buildings or other equipment owned or rented by the Contractor, its Subcontractors, or any Worker.

C. Named Insured: Each Insurance policy certificate of insurance provided by the Contractor shall name the Town of Arlington as an additional insured. Each insurance policy and certificate of insurance provided by the Contractor shall contain a provision that the Owner shall be notified of cancellation or restrictive amendment at least thirty (30) days prior to the effective date of such cancellation or amendment.

D. Insurance Certificates: Submit insurance certificates for the Owner's review and approval prior to commencement of the work. The Contractor and all subcontractors who are required to provide insurance under the Contract shall provide accurate and bona fide "Certificates of insurance "issued by a responsible agent of the insurance company.

1. Certificate Content: Such "Certificates of Insurance" shall clearly indicate the insurance coverage. Each "Certificate of Insurance" shall be accompanied by a sworn and duly notarized statement from the responsible agent of the insurance company issuing the certificate clearly stating that all insurance specified and required by the Contract Documents is provided and in force, and also a clear statement of all exceptions and deviations, if any, from the Contract Document issuance requirements.

2. Responsibility: The insurance agent issuing and authorizing the "Certificate of Insurance" shall be responsible and liable for the accuracy and validity of the "Certificate of Insurance". Each insured party shall certify by sworn and duly notarized statement that the "Certificate of Insurance" issued for them are bona fide.

3. Disclaimers Prohibited: "Certificates of Insurance" shall not contain any disclaimers such as: "This Certificate is issued as a matter of information only and confers no right upon the certificate holder. This Certificate does not amend, extend, or alter the coverage afforded by the policies listed below." Disclaimers are not acceptable.

4. Certificates of Insurance Can Be Relied Upon: Parties receiving "Certificates of insurance" shall be entitled to rely upon the "Certificates of insurance" and shall have the right to claim the benefits and protection provided by the insurance as it applies to them.

5. Alternate to "Certificates of Insurance": Instead of providing the "Certificates of Insurance" and the sworn statements required above, the insured may provide bona fide and accurate copies of all insurance policies and riders accompanied by a sworn and duly notarized statement from the insured that the policies, riders, and documents submitted are bona fide and valid, and that parties receiving the insurance documents may rely on the documents as satisfaction of the Contract insurance requirements.

E. The Contractor shall provide "builder's risk" insurance as described in the General Conditions of the Contract for Construction and with limits equal to the full insurable completed value of the building under construction. The "Builder's Risk" insurance shall include "all risk" insurance for physical loss and damage including theft, vandalism, and malicious mischief. The "Builder's Risk" insurance shall be amended to delete any and all endorsements relating to cancellation of the policy due to partial occupancy by the Owner.

1. Builder's Risk Deductible Amount: \$1,000,000.00

END OF SECTION

TABLE OF CONTENTS

PLAYGROUND AT PEIRCE ELEMENTARY SCHOOL TECHNICAL SPECIFICATIONS

PREPARED BY WESTON & SAMPSON

DIVISION 01: GENERAL

01 11 00	Control of Work and Materials
01 12 16	Scope and Sequence of Work
01 14 19.16	Dust Control
01 14 19.19	Existing Fences
01 33 23	Submittals
01 55 26.13	Signage (Traffic Control)
01 56 26	Temporary Chain Link Fence
01 57 16	Rodent Control
01 57 19	Environmental Protection
01 74 13	Cleaning-Up
01 78 00	Project Closeout
01 78 39	Project As-Built Record Drawings
01 92 13	Operations and Maintenance Manuals

DIVISION 02: EXISTING CONDITIONS

02 41 13	Selective Site Demolition
----------	---------------------------

DIVISION 03: CONCRETE

03 11 00	Concrete Formwork
03 21 00	Concrete Reinforcement
03 30 00	Cast-in-Place Concrete

DIVISION 04: MASONRY

04 40 00	Dry-Placed Boulders
----------	---------------------

DIVISION 05: METALS

05 50 00	Miscellaneous Metals
----------	----------------------

DIVISION 06: CARPENTRY

06 10 00	Rough Carpentry
06 20 00	Finish Carpentry

DIVISION 11: EQUIPMENT

11 68 13 Playground Equipment

DIVISION 12: FURNISHINGS

12 93 00 Site Furnishings

DIVISION 31: EARTHWORK

31 00 00 Earthwork
31 05 13.13 Loam Borrow
31 05 19.13 Geotextile Fabrics
31 11 00 Clearing and Grubbing
31 13 13 Tree Pruning and Tree and Stump Removals
31 23 00 Excavation, Borrow, and Backfill
31 23 19 Dewatering
31 50 00 Support of Excavation

DIVISION 32: EXTERIOR IMPROVEMENTS

32 11 00 Sidewalk Construction and Replacement
32 18 00 Poured in Place Safety Surfacing
32 31 00 Fences and Gates
32 93 00 Trees, Shrubs, Groundcovers and Landscaping
32 96 43 Tree Transplanting

DIVISION 33: UTILITIES

33 05 26.13 Tracer Tape
33 31 13.46 Connections to Existing Structures
33 39 13 Precast Manholes
33 41 13.22 Corrugated Polyethylene (HDPE) Drainage Pipe

APPENDICES:

Appendix A. Manufacturer's Specifications and/or Cut Sheets

SECTION 01 11 00

CONTROL OF WORK AND MATERIALS

PART 1 – GENERAL

Not Used.

PART 2 – PRODUCTS

Not Used

PART 3 - EXECUTION

3.01 HAULING, HANDLING AND STORAGE OF MATERIALS:

- A. The Contractor shall, at its own expense, handle and haul all materials furnished by it and shall remove any of its surplus materials at the completion of the work.
- B. The Contractor shall provide suitable and adequate storage for equipment and materials furnished by it that are liable to injury and shall be responsible for any loss of or damage to any equipment or materials by theft, breakage, or otherwise.
- C. All excavated materials and equipment to be incorporated in the Work shall be placed so as not to injure any part of the Work or existing facilities and so that free access can be had at all times to all parts of the Work and to all public utility installations in the vicinity of the work. Materials and equipment shall be kept neatly piled and compactly stored in such location as will cause a minimum of inconvenience to public travel and adjoining owners, tenants and occupants.
- D. The Contractor shall be responsible for all damages to the work under construction during its progress and until final completion and acceptance even though partial payments have been made under the Contract.

3.02 OPEN EXCAVATIONS:

- A. All open excavations shall be adequately safeguarded by providing temporary barricades, caution signs, lights and other means to prevent accidents to persons, and damage to property. The Contractor shall, at its own expense, provide suitable and safe means for completely covering all open excavations and for accommodating travel when work is not in progress.
- B. Bridges provided for access to private property during construction shall be removed when no longer required.
- C. The length of open trench will be controlled by the particular surrounding conditions but

shall always be confined to the limits prescribed by the Engineer.

- D. If the excavation becomes a hazard, or if it excessively restricts traffic at any point, then special construction procedures shall be taken, such as limiting the length of trench and prohibiting stocking excavated material in the street.

3.03 MAINTENANCE OF TRAFFIC:

- A. Unless permission to close the street is received in writing from the proper authority, all excavated materials and equipment shall be placed so that vehicular and pedestrian traffic may be safely maintained at all times.
- B. Should the Chief of Police deem it necessary, uniformed officers will be assigned to direct traffic. The Contractor shall make all arrangements in obtaining uniformed officers required.
- C. The Contractor shall at its own expense, as directed by the Police Traffic Control/Safety Officer, provide and erect acceptable barricades, barrier fences, traffic signs, and all other traffic devices not specifically covered in a bid item, to protect the work from traffic, pedestrians, and animals. The Contractor shall provide sufficient temporary lighting such as lanterns/flashers (electric battery operated) or other approved illuminated traffic signs and devices to afford adequate protection to the traveling public, at no additional cost to the Owner.
- D. The Contractor shall furnish all construction signs that are deemed necessary by and in accordance with Part VI of the Manual on Uniform Traffic Control Devices as published by the U.S. Department of Transportation. In addition, the Contractor may be required to furnish up to 128 square feet of additional special construction warning signs. Size and exact wording of signs shall be determined by the Engineer during construction.
- E. The intent of policing is to ensure public safety by direction of traffic. Police officers are not to serve as watchmen to protect the Contractor's equipment and materials.
- F. Nothing contained herein shall be construed as relieving the Contractor of any of its responsibilities for protection of persons and property under the terms of the Contract.

3.04 CARE AND PROTECTION OF PROPERTY:

The Contractor shall be responsible for the preservation of all public and private property, and shall use every precaution necessary to prevent damage thereto. If any direct or indirect damage is done to public or private property by or on account of any act, omission, neglect, or misconduct in the execution of the work on the part of the Contractor, such property shall be promptly restored by the Contractor, at its expense, to a condition similar or equal to that existing before the damage was done, to the satisfaction of the Engineer.

3.06 PROTECTION AND RELOCATION OF EXISTING STRUCTURES AND

UTILITIES:

- A. All existing buildings, utilities, pipes, poles, wires fences, curbing, property line markers and other structures which the Engineer decides must be preserved in place without being temporarily or permanently relocated, shall be carefully supported and protected from damage by the contractor. Should such property be damaged, it shall be restored by the Contractor, at no additional cost to the Owner.
- B. The Contractor shall determine the location of all underground structures and utilities (including existing water services, drain lines, electrical lines, and sewers). Services to buildings shall be maintained, and all costs or charges resulting from damage thereto shall be paid by Contractor.
- C. When fences interfere with the Contractor's operations, it shall remove and (unless otherwise specified) promptly restore them in accordance with Section 01 14 19.19 EXISTING FENCES.
- D. On paved surfaces the Contractor shall not use or operate tractors, bulldozers, or other power-operated equipment with treads or wheels which are shaped so as to cut or otherwise damage such surfaces.
- E. All property damaged by the Contractor's operations shall be restored to a condition at least equal to that in which it was found immediately before work was begun. Suitable materials and methods shall be used for such restoration.
- F. Restoration of existing property and structures shall be carried out as promptly as practicable and shall not be left until the end of the construction period.

3.05 MAINTENANCE OF FLOW:

- A. The Contractor shall at its own cost, provide for the flow of sewers and drains interrupted during the progress of the work, and shall immediately cart away and dispose of all offensive matter. The entire procedure of maintaining existing flow shall be fully discussed with the Engineer well in advance of the interruption of any flow.
- B. All existing drainage facilities including, but not limited to; brooks, streams, canals, channels, ditches, culverts, catch basins and drainage piping shall be adequately safeguarded so as not to impede drainage or to cause siltation of downstream areas in any manner whatsoever. If the Contractor damages or impairs any of the aforesaid drainage facilities, it shall repair the same within the same day.
- C. At the conclusion of the work, the Contractor shall remove all silt in drainage structures caused by its operations as described in Section 01 74 13, CLEANING UP.

3.06 REJECTED MATERIALS AND DEFECTIVE WORK:

- A. Materials furnished by the Contractor and condemned by the Engineer as unsuitable or

not in conformity with the specifications shall forthwith be removed from the work by the Contractor, and shall not be made use of elsewhere in the work.

- B. Any errors, defects or omissions in the execution of the work or in the materials furnished by the Contractor, even though they may have been passed or overlooked or have appeared after the completion of the work, discovered at any time before the final payment is made hereunder, shall be forthwith rectified and made good by and at the expense of the Contractor and in a manner satisfactory to the Engineer.
- C. The Contractor shall reimburse the Owner for any expense, losses or damages incurred in consequence of any defect, error, omission or act of the Contractor or his employees, as determined by the Engineer, occurring previous to the final payment.

3.07 SANITARY REGULATIONS:

Sanitary conveniences for the use of all persons employed on the work, properly screened from public observation, shall be provided in sufficient numbers in such manner and at such locations as may be approved. The contents shall be removed and disposed of in a satisfactory manner as the occasion requires. The Contractor shall rigorously prohibit the committing of nuisances within, on or about the work. Any employees found violating these provisions shall be discharged and not again employed on the work without the written consent of the Engineer. The sanitary conveniences specified above shall be the obligation and responsibility of the Contractor.

3.08 SAFETY AND HEALTH REGULATIONS:

This project is subject to the Safety and Health regulations of the U.S. Department of Labor set forth in 29 CFR, Part 1926, and to the Massachusetts Department of Labor and Industries, Division of Industrial Safety "Rules and Regulations for the Prevention of Accidents in Construction Operations (454 CMR 10.0 et. seq.)." The Contractor shall be familiar with the requirements of these regulations.

3.09 SITE INVESTIGATION:

The Contractor acknowledges that it has satisfied itself as to the conditions existing at the site of the work, the type of equipment required to perform this work, the quality and quantity of the materials furnished insofar as this information is reasonably ascertainable from an inspection of the site, as well as from information presented by the drawings and specifications made a part of this contract. Any failure of the Contractor to acquaint itself with available information will not relieve it from the responsibility for estimating properly the difficulty or cost of successfully performing the work. The Owner assumes no responsibility for any conclusion or interpretation made by the Contractor on the basis of the information made available by the Owner.

3.10 WEATHER PROTECTION:

In conformance with Sections 44F and 44G of Chapter 149 of the General Laws of

Massachusetts, the General Contractor shall install weather protection and shall furnish adequate heat in the area so protected during the months of November through March. Standards for such specifications shall be established by the Director of Building Construction in the Executive Office for Administration and Finance.

3.11 ELECTRIC SERVICE:

- A. The Contractor shall make all necessary applications and arrangements and pay for all fees and charges for electrical energy for power and light necessary for the proper completion of this contract during its entire progress. The Contractor shall provide and pay for all temporary wiring, switches, connections, and meters.
- B. There shall be sufficient electric lighting so that all work may be done in a workmanlike manner where there is not sufficient daylight.

3.12 HAZARDOUS WASTE:

Should the Contractor, while performing work under this contract, uncover hazardous materials, as defined in Massachusetts Hazardous Waste Regulations 310 CMR 30.00, he shall immediately notify the Engineer. The Contractor is not, and has no authority to act as, a handler, generator, operator or disposer of hazardous or toxic substances found or identified at the site, and the Owner shall undertake all such functions.

END OF SECTION

SECTION 01 12 16

SCOPE AND SEQUENCE OF WORK

PART 1 – GENERAL

1.01 WORK INCLUDED:

- A. Furnishing all labor, materials and equipment necessary to make improvements to the park by demolition and site preparation as described in the Contract Drawings and installing new concrete walkways, fencing, site furniture, play equipment, safety surfacing, planting and landscape restoration.

1.02 RELATED WORK:

- A. SECTION 01 11 00 – CONTROL OF WORK AND MATERIALS

PART 2 - PRODUCTS (NOT APPLICABLE)

PART 3 - EXECUTION

3.01 GENERAL:

- A. The Contractor shall be responsible for scheduling its activities and the activities of any subcontractors involved, to meet the completion date, or milestones, established for the contract. Scheduling of the work shall be coordinated with the Owner and Engineer.
- B. The Construction Sequence Requirements shall be used by the Contractor to form a complete schedule for the project, which shall be coordinated with the Owner and Engineer. Prior to performing any work at the site, the Contractor shall submit a detailed plan to the Engineer for review. The plan shall describe the proposed sequence, methods, and timing of the work.

3.02 CONSTRUCTION SEQUENCING REQUIREMENTS:

- A. Project must be completed within number of days stated in the front end of the specification. Contractor is responsible for meeting all interim deadlines established as part of the construction schedule that will ensure timely completion of the project.

END OF SECTION

SECTION 01 14 19.16

DUST CONTROL

PART 1 - GENERAL

1.01 DESCRIPTION:

This section of the specification covers the control of dust via calcium chloride and water, complete.

PART 2 - PRODUCTS

2.01 CALCIUM CHLORIDE:

- A. Calcium chloride shall conform to the requirements of AASHTO-M 144, Type I or Type II and Specification for Calcium Chloride, ASTM D98. The calcium chloride shall be packaged in moisture proof bags or in airtight drums with the manufacturer, name of product, net weight, and percentage of calcium chloride guaranteed by the manufacturer legibly marked on each container.
- B. Calcium chloride failing to meet the requirements of the aforementioned specifications or that which has become caked or sticky in shipment, may be rejected by the Engineer.

2.02 WATER:

- A. Water shall not be brackish and shall be free from oil, acid, and injurious alkali or vegetable matter.

PART 3 - EXECUTION

3.01 APPLICATION:

- A. Calcium chloride shall be applied when ordered by the Engineer and only in areas which will not be adversely affected by the application. See Section 01 57 19, ENVIRONMENTAL PROTECTION.
- B. Calcium chloride shall be uniformly applied at the rate of 1-1/2 pounds per square yard or at any other rate as required by the Engineer. Application shall be by means of a

mechanical spreader, or other approved methods. The number and frequency of applications shall be determined by the Engineer.

- C. Water may be sprinkler applied with equipment including a tank with gauge-equipped pressure pump and a nozzle-equipped spray bar.
- D. Water shall be dispersed through the nozzle under a minimum pressure of 20 pounds per square inch, gauge pressure.

END OF SECTION

SECTION 01 14 19.19

EXISTING FENCES

PART 1 - GENERAL

1.01 DESCRIPTION:

- A. This section of the specification covers the removal and resetting of existing fences.
- B. Where the removal of existing fences, at locations shown on the plans and where required by the Engineer, is required, the Contractor shall remove and reset such fences as required by the Engineer.

PART 2 - PRODUCTS

2.01 FENCING:

- A. The materials removed shall be utilized to reset the fence. Where necessary, new posts and bases shall be furnished and installed by the Contractor. Any materials damaged or lost during or subsequent to removal shall be replaced by the Contractor without additional compensation.
- B. All new materials required shall be equal in quality and design to the materials in the present fences.

PART 3 - EXECUTION

3.01 REMOVAL OF EXISTING FENCES:

- A. The present fences shall be carefully removed together with all appurtenances and satisfactorily stored and protected until required for resetting.

3.02 ERECTION:

- A. Fences shall be reset plumb and to the grades required and shall conform to the original fence or as the Engineer requires. Backfilling around the posts shall consist of suitable material satisfactorily compacted. If the fence posts were originally set in concrete bases they shall be reset in concrete bases.

3.03 PAINTING:

- A. Painting, if required, shall be done as required by the Engineer.

END OF SECTION

SECTION 01 33 23

SUBMITTALS

PART 1 - GENERAL

1.01 WORK INCLUDED:

- A. The Contractor shall provide the Engineer with submittals as required by the contract documents.

1.02 RELATED WORK:

- A. Divisions 1 – 33 of these specifications that require submittals.

PART 2 - PRODUCTS

NOT USED

PART 3 - EXECUTION

3.01 GENERAL:

- A. As required by the General Conditions, Contractor shall submit a schedule of shop and working drawing submittals.
- B. The Contractor shall submit the shop and working drawing submittals either electronically or hard copy.

3.02 ELECTRONIC SUBMITTALS:

- A. In accordance with the accepted schedule, the Contractor shall submit promptly to the Engineer by email (FOBrien@town.arlington.ma.us), one electronic copy in Portable Document Format (PDF) of shop or working drawings required as noted in the specifications, of equipment, structural details and materials fabricated especially for this Contract.
- B. Each electronic copy of the shop or working drawing shall be accompanied by the Engineer's standard shop drawing transmittal form, included as Exhibit 1 of this section (use only for electronic submittals), on which is a list of the drawings, descriptions and numbers and the names of the Owner, Project, Contractor and building, equipment or structure.
- C. The Contractor shall receive a shop drawing memorandum with the Engineer's approval or comments via email.

3.03 HARD COPY SUBMITTALS:

- A. In accordance with the accepted schedule, the Contractor shall submit promptly to the Engineer, by mail (to Weston & Sampson Engineers, attention: CSD), six (6) copies each of shop or working drawings required as noted in the specifications, of equipment, structural details and materials fabricated especially for this Contract.
- B. Each shipment of drawings shall be accompanied by the Engineer's (if applicable) standard shop drawing transmittal form on which is a list of the drawings, descriptions and numbers and the names of the Owner, Project, Contractor and building, equipment or structure.

3.04 SHOP AND WORKING DRAWINGS:

- A. Shop and working drawings shall show the principal dimensions, weight, structural and operating features, space required, clearances, type and/or brand of finish of shop coat, grease fittings, etc., depending on the subject of the drawings. When it is customary to do so, when the dimensions are of particular importance, or when so specified, the drawings shall be certified by the manufacturer or fabricator as correct for this Contract.
- B. All shop and working drawings shall be submitted to the Engineer by and/or through the Contractor, who shall be responsible for obtaining shop and working drawings from his subcontractors and returning reviewed drawings to them. All shop and working drawings shall be prepared on standard size, 24-inch by 36-inch sheets, except those, which are made by changing existing standard shop or working drawings. All drawings shall be clearly marked with the names of the Owner, Project, Contractor and building, equipment or structure to which the drawing applies, and shall be suitably numbered. Each shipment of drawings shall be accompanied by the Engineer's (if applicable) standard shop drawing transmittal form on which is a list of the drawings, descriptions and numbers and the names mentioned above.
- C. Only drawings that have been prepared, checked and corrected by the fabricator should be submitted to the Contractor by his subcontractors and vendors. Prior to submitting drawings to the Engineer, the Contractor shall check thoroughly all such drawings to satisfy himself that the subject matter thereof conforms to the Contract Documents in all respects. Shop drawings shall be reviewed and marked with the date, checker's name and indication of the Contractor's approval, and only then shall be submitted to the Engineer. Shop drawings unsatisfactory to the Contractor shall be returned directly to their source for correction, without submittal to the Engineer. Shop drawings submitted to the Engineer without the Contractor's approval stamp and signature will be rejected. Any deviation from the Contract Documents indicated on the shop drawings must be identified on the drawings and in a separate submittal to the Engineer, as required in this section of the specifications and General Conditions.
- D. The Contractor shall be responsible for the prompt submittal and resubmittal, as necessary, of all shop and working drawings so that there will be no delay in the work

due to the absence of such drawings.

- E. The Engineer will review the shop and working drawings as to their general conformance with the design concept of the project and general compliance with the information given in the Contract Documents. Corrections of comments made on the drawings during the review do not relieve the Contractor from compliance with requirements of the Contract Documents. The Contractor is responsible for: confirming and correlating all quantities and dimensions; selecting fabrication processes and techniques of construction; coordinating his work with that of all other trades; and performing his work in a safe and satisfactory manner. The review of the shop drawings is general and shall not relieve the Contractor of the responsibility for details of design, dimensions, code compliance, etc., necessary for interfacing with other components, proper fitting and construction of the work required by the Contract and for achieving the specified performance. The Engineer will review submittals two times: once upon original submission and a second time if the Engineer requires a revision or corrections. The Contractor shall reimburse the Owner amounts charged to the Owner by the Engineer for performing any review of a submittal for the third time or greater.
- F. With few exceptions, shop drawings will be reviewed and returned to the Contractor within 30 days of submittal.
- G. No material or equipment shall be purchased or fabricated especially for this Contract nor shall the Contractor proceed with any portion of the work, the design and details of which are dependent upon the design and details of equipment or other features for which review is required, until the required shop and working drawings have been submitted and reviewed by the Engineer as to their general conformance and compliance with the project and its Contract Documents. All materials and work involved in the construction shall then be as represented by said drawings.
- H. Two copies of the shop and working drawings and/or catalog cuts will be returned to the Contractor. The Contractor shall furnish additional copies of such drawings or catalog cuts when he needs more than two copies or when so requested.

3.05 SAMPLES:

- A. Samples specified in individual Sections include, but are not necessarily limited to, physical examples of the work such as sections of manufactured or fabricated work, small cuts or containers of materials, complete units of repetitively-used products, color/texture/pattern swatches and range sets, specimens for coordination of visual effect, graphic symbols, and units of work to be used by the Engineer or Owner for independent inspection and testing, as applicable to the work.
- B. The number of samples submitted shall be as specified. Submittal and processing of samples shall follow the procedures outlined for shop and working drawings unless the specifications call for a field submittal or mock-up.

- C. Acceptance of samples will be acknowledged via a copy of the transmittal noting status. When samples are not acceptable, prompt resubmittal will be required.

3.06 OPERATING AND MAINTENANCE MANUALS AND SPARE PARTS LISTS:

- A. Where reference is made in technical specification sections to operating and maintenance manuals and/or spare parts lists, the Contractor shall submit four copies to the Engineer for review in accordance with the instructions furnished under "Shop and Working Drawings." If the submittal is complete and does not require any changes, an acknowledgement (copy of transmittal) will be returned noting status. If the submittal is incomplete or does require changes, corrections, additions, etc., two copies of the submittal will be returned with a copy of transmittal noting status. Four copies of the final operating and maintenance manuals and/or spare parts list shall be delivered to the Engineer prior to or with the equipment when it is delivered to the job site. For systems requiring field adjustment and balancing, such as heating and ventilating, the Contractor shall submit separate test results and adjustment data on completion of the work, to be incorporated into the system manual.
- B. The information included in the manual shall be as described in the specification sections, but as a minimum shall contain clear and concise instructions for operating, adjusting, lubricating and maintaining the equipment, an exploded assembly drawing identifying each part by number and a listing of all parts of the equipment, with part numbers and descriptions required for ordering spare parts. Spare parts lists shall include recommended quantity and price.
- C. Operating and maintenance manuals shall be in durable loose-leaf binders, on 8½-inch by 11-inch paper, with diagrams and illustrations either on 8½-inch by 11 inch or multiple foldouts. The instructions shall be annotated to indicate only the specific equipment furnished. Reference to other sizes or models of similar requirement shall be deleted or neatly lined out.

END OF SECTION

EXHIBIT 1 TO SECTION 01 33 23 SUBMITTALS

SHOP DRAWING TRANSMITTAL FORM

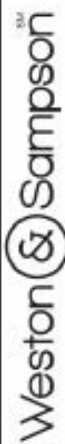

Shop Drawing Transmittal

Instruction for Preparing Transmittal
 No action will be taken on any item unless accompanied by this form.
 TRANSMITTAL NOS. to be consecutive (1, 2, 3, etc.).
 Each resubmittal of same item shall use same number with suffix letter (A, B, etc.).
 SPEC. SECT. NO.: Only one spec. section no. to each transmittal.
 DESCRIPTION: Complete identification of document or group of documents.
 SOURCE: Originator of document(s) being submitted.

DRAWING NO.: Identification of document(s).
 CONTRACT DRAWING REFERENCE: Contract drawing number(s) showing details of document(s).
 SPECIAL INSTRUCTIONS: Special cases and emergencies, changes in distribution and special handling requests, etc. should be entered here.
 SIGNATURE OF CONTRACTOR: Signature of individual who reviews and approves material prior to submittal to engineer.

THIS SECTION TO BE COMPLETED BY CONTRACTOR

TRANSM. NO.	SPEC. SECT. NO.	DATE	CONTRACTORS JOB NO.	W&S JOB NO.
PROJECT NAME & CONTRACT NO.				
LOCATION				

Attention: [CSD \(David@wsainc.com\)](mailto:David@wsainc.com)
 Weston & Sampson Engineers, Inc.
 5 Centennial Drive
 Peabody, MA 01960-7985

F
R
O
M

ITEM NO.	DESCRIPTION	SOURCE	DRAWING NO. CATALOG NO. BROCHURE, ETC	NO. OF COPIES	CONTRACT DRAWING REF.	By W&S	
						ACTION CODE	REVIEWED BY
1							
2							
3							
4							

THIS CERTIFIES THAT ALL ITEMS SUBMITTED HERewith HAVE BEEN CHECKED BY THE CONTRACTOR, ARE IN CONFORMANCE WITH THE REQUIREMENTS OF THE CONTRACT DOCUMENTS, EXCEPT AS NOTED, AND ARE APPROVED BY THE CONTRACTOR FOR THIS PROJECT.

THIS SECTION TO BE COMPLETED BY WESTON & SAMPSON

ACTION CODE:	WESTON & SAMPSON
1. NO EXCEPTIONS TAKEN	SIGNATURE & TITLE
2. MAKE CORRECTIONS NOTED	
3. AMEND AND RESUBMIT	
4. REJECTED-SEE REMARKS	
5. ACKNOWLEDGEMENT	
6. SUBMITTAL NOT REQUIRED, RETURNED WITHOUT REVIEW	

8. INSTALLATION SHALL PROCEED ONLY WHEN ACTION CODE IS 1 OR 2
 b. ACTION CODED 3 SHALL BE RESUBMITTED WITHIN TIME LIMIT SET IN CONTRACT
 c. REVIEW DOES NOT RELIEVE CONTRACTOR FROM RESPONSIBILITY OF COMPLIANCE WITH ALL REQUIREMENTS OF THE CONTRACT DOCUMENTS

SECTION 01 55 26.13

SIGNAGE (TRAFFIC CONTROL)

PART 1 - GENERAL

1.01 WORK INCLUDED:

This Section covers furnishing and installing traffic control signs and other devices.

1.02 SYSTEM DESCRIPTION:

The Contractor shall furnish and install all construction signs deemed necessary by and in accordance with the latest edition of Part VI of the Manual on Uniform Traffic Control Devices (MUTCD) as published by the U.S. Department of Transportation.

PART 2 - PRODUCTS

2.01 TRAFFIC WARNING AND REGULATING DEVICES:

Contractor shall provide warning signs, barricades and other devices in accordance with the specifications provided in the MUTCD. Size of signs, lettering, colors, method of support and other factors prescribed in the MUTCD shall be adhered to.

PART 3 - EXECUTION

3.01 INSTALLATION:

- A. Contractor shall erect barricades, barrier fences, traffic signs, and other traffic control devices as required by the MUTCD, or as required by the Engineer, to protect the work area from traffic, pedestrians, and animals.
- B. Contractor shall relocate barricades, signs and other devices as necessary as the work progresses.
- C. Unless extended protection is required for specific areas, when the work has been completed, all temporary warning and regulatory devices used by the Contractor shall be removed so that traffic can move unimpeded through the area.

END OF SECTION

SECTION 01 56 26

TEMPORARY CHAIN LINK FENCE

PART 1 - GENERAL

1.01 WORK INCLUDED:

- A. The Contractor shall provide all labor, materials and appurtenances necessary for the installation, maintenance and dismantling of 6-foot temporary fencing.
- B. The Contractor shall be responsible for securing the site from trespassers. Existing fencing exists on portions of the site as shown on the Contract Drawings; it will be at the discretion of the Contractor to determine whether the existing fence is suitable for site safety and security. The Contractor shall install temporary fencing across lengths of damaged/unsuitable fencing to secure the site and prevent trespassers.

1.02 SUBMITTALS: IN ACCORDANCE WITH REQUIREMENTS OF SECTION 01 33 23 SUBMITTALS, SUBMIT THE FOLLOWING:

- A. Manufacturer's literature of the materials specified herein.
- B. Shop drawings of the temporary chain link fence and gates.
 - 1. Shop drawings shall indicate layout of temporary fencing, location and size of gates, existing pavement and roads, and other site-specific conditions. Prepare drawing after site observation and verification of existing conditions.

PART 2 - PRODUCTS-GALVANIZED

2.01 TEMPORARY CHAIN LINK FENCING

- A. Unless otherwise indicated, type of 6-foot temporary chain link fencing shall be Contractor's option. Following types are acceptable:
 - 1. New materials or previously used salvaged chain link fencing in good condition.
 - 2. Posts: Galvanized steel pipe of diameter to provide rigidity. Post shall be suitable for setting in concrete footings, driving into ground, anchoring with base plates, or inserting in precast concrete blocks.
 - 3. Fabric: Woven galvanized steel wire mesh. Provide in continuous lengths to be wire tied to fence posts or prefabricated into modular pipe-framed fence panels.
- B. Gates: Provide gates of the quantity and size indicated on the Contract Drawings or required for functional access to Site.

1. Fabricate of same material as used for fencing.
2. Vehicle gates:
 - a. Capable of manual operation by one person.

PART 3 - EXECUTION

3.01 INSTALLATION

- A. The fence and gates shall be erected by skilled mechanics in accordance with the recommendations of the manufacturer and these specifications. These specifications shall take precedence over the recommendations of the manufacturer if any discrepancy exists between them.
- B. Posts
 1. Maximum post spacing shall be 10-feet. Post spacing shall be uniform and posts shall be plumb.
 2. Drive posts, set in holes and backfill, or anchor in precast concrete blocks.
 3. For soft and unstable ground conditions, cast concrete plug around post.
 4. Posts over pavement: Use steel post plates or precast concrete blocks.
 5. Gate posts: Use bracing or concrete footings to provide rigidity for accommodating size of gate.
 6. Temporary terminal posts shall be securely connected to existing fence posts to prevent site access/trespassing.
- C. Securely attach wire fabric to posts. Maximum area of unbraced fence fabric shall not exceed 1,500 square feet.
- D. Install with required hardware.
- E. Fabric shall be stretched taut, with the bottom edge following the existing grade, and shall be a continuous mesh between terminal posts. Each span of fabric shall be attached independently at terminal posts. Where terminal posts do not have provisions for weaving fabric to posts, stretcher bars shall be placed through the end weave of the fabric and secured to the post with bar bands spaced not more than 15-inches apart on the post. Temporary terminal posts shall be secured to existing fence posts to prevent Site access/trespassing.
- F. Fabric shall be attached with ties to line posts at intervals of not more than 14-inches (and to the top railing and braces at intervals not exceeding 24-inches).

- G. The bottom tension wire shall be interlaced in the weave of the fabric, pulled taut and fastened to terminal posts.

3.02 MAINTENANCE AND REMOVAL

- A. Maintain fencing in good condition. If damaged, immediately repair.
- B. Remove temporary fencing upon completion of Work or when no longer required for security or control. Backfill holes and compact. Holes in pavement shall be surfaced to match existing paving. Repair damage caused by installation of temporary fencing.

END OF SECTION

SECTION 01 57 16

RODENT CONTROL

PART 1 - GENERAL

1.01 WORK INCLUDED:

- A. This section specifies requirements for rodent control activities by the Contractor at all work and laydown (or staging) areas in connection with this Contract.
- B. The Contractor shall retain the services of a licensed rodent exterminator to conduct an inspection of the work and laydown areas and report on the presence of rodents and take any necessary measures to eliminate existing rodent populations prior to start of work.

1.02 SUBMITTALS: IN ACCORDANCE WITH REQUIREMENTS OF GENERAL SPECIFICATIONS, SUBMIT THE FOLLOWING:

- A. Within ten days after Notice to Proceed, submit to the Engineer a written description of rodent control measures to be used and the areas to be included in the program.
- B. Provide the name and background of the licensed rodent exterminator retained to provide any necessary rodent eradication measures prior to start of work.

PART 2 - PRODUCTS

2.01 CONTAINERS:

Use metal or heavy-duty plastic refuse containers with tight-fitting lids for disposal of all garbage, or trash associated with food. These containers shall not have openings that allow access by rodents.

PART 3 - EXECUTION

3.01 WORK AND LAYDOWN AREAS WITHIN THE CONTRACT AREA:

- A. Before mobilization begins, obtain written verification from the rodent exterminator that rodent populations have been effectively controlled in areas to be occupied.
- B. Following site clearing and before demolition, excavation, or construction, inspect work and laydown areas and remove all remaining trash, debris, and weeds.
- C. Maintain work and laydown areas free of trash, garbage, weeds, and debris. Provide and enforce proper use of refuse containers to ensure that rodents and other pests are not harbored or attracted.

- D. Designate specific locations as lunch and coffee break areas to prevent random disposal of garbage and trash. Keep those areas free of litter and garbage, and provide refuse containers as described in 2.01 of this section. Keep refuse containers upright with their lids shut tight.
- E. Have all refuse containers emptied daily to maintain site sanitation.
- F. Notify the Engineer within 24 hours whenever rodents (rats or mice) or signs of rodent activity (burrows or droppings) are observed in work or laydown areas. Take appropriate action to locate and control the rodents.

3.02 LAYDOWN AREAS OUTSIDE THE CONTRACT AREA:

- A. Implement pest control at all laydown areas that are not areas of this Contract, but that are used by the Contractor in connection with this Contract. Undertake rodent control at least two weeks prior to use of the area and with time to ensure that the site is free of rodent populations (rats and mice) prior to site occupancy. Maintain the site free of rodents throughout the duration of its use.
- B. Clear laydown areas of trash, debris, and weeds prior to occupancy. Initiate those actions only after rodent populations have been effectively controlled.
- C. Maintain laydown areas free of trash, garbage, weeds, and debris. Provide and enforce proper use of refuse containers to ensure that rodents and other pests are not harbored or attracted.
- D. Dispose of all garbage or trash associated with food in refuse containers with tight-fitting lids as described in 2.01 of this Section. Have refuse containers emptied daily to maintain site sanitation.

END OF SECTION

SECTION 01 57 19

ENVIRONMENTAL PROTECTION

PART 1 – GENERAL

1.01 DESCRIPTION:

- A. The work covered by this section of the specifications consists of furnishing all labor, materials, tools and equipment and performing all work required for the prevention of environmental pollution during and as a result of construction operations under this contract.
- B. All work under this Contract shall be in accordance with the Conservation Commissions' Orders of Conditions as well as any conditional requirements applied.
- C. Prior to commencement of work, the Contractor shall meet with representatives of the Engineer to develop mutual understandings relative to compliance of the environmental protection program.

1.02 RELATED WORK:

- A. Section 00 31 43, PERMITS
- B. Section 01 14 19.16, DUST CONTROL
- C. Section 01 33 23, SUBMITTALS
- D. Section 31 00 00, EARTHWORK
- F. Section 31 11 00, CLEARING AND GRUBBING
- G. Section 31 23 19, DEWATERING
- H. Section 31 50 00, SUPPORT OF EXCAVATION

PART 2 - PRODUCTS

2.01 SILT FENCE:

- A. The silt fence shall consist of a 3-foot wide continuous length sediment control fabric, stitched to a mesh backing, and stapled to preweathered oak posts installed as shown on the drawings. The oak posts shall be 1-1/4-inches by 1-1/4-inches (Minimum Dimension) by 48-inches and shall be tapered. The bottom edge of the silt fence shall be buried as shown on the drawings.

- B. The silt fence shall be DOT Silt Fence PPDM3611, as manufactured by U.S. Silt & Site Supply/Getsco, Concord, NH, or approved equal.
- C. Silt fence properties:

<u>Physical Properties</u>	<u>Test Method</u>	<u>Minimum Value</u>
Grab Strength, lbs.	ASTM-D-4632	124
Grab Elongation, %	ASTM-D-4632	15
Mullen burst, psi	ASTM-D-3786	300
Puncture, lbs.	ASTM-D-4833	65
Trapezoidal Tear, lbs.	ASTM-D-4833	65
UV Resistance ² , % ³	ASTM-D-4355	80@500 hrs.
AOS, US Sieve No.	ASTM-D-4751	30
Flow Rate, gal/min/sq ft	ASTM-D-4491	10
Permittivity,(1/sec)gal/min/sq ft	ASTM-D-4491	0.05 sec ⁻¹

2.02 STRAW BALES:

- A. Straw bales shall consist of certified seed free stems of agricultural grain and cereal crops and shall be free of grasses and legumes. Standard bales shall be 14-inches high, 18- inches wide and 36- to 40-inches long tied with polypropylene twine and weigh within 5 percent of 7 lbs. per cubic ft.

2.03 STRAW WATTLES:

- A. Straw Wattles shall consist of a 100% biodegradable exterior jute or coir netting with 100% wheat straw interior filling as manufactured by GEI Works, Sebastian, Florida (Phone: 772-646-0597; website: www.erosionpollution.com), or approved equal.

2.04 CATCH BASIN PROTECTION:

- A. To trap sediment and to prevent sediment from clogging drainage systems, catch basin protection in the form of a siltation sack (Siltsack as manufactured by ACF Environmental, Inc. or approved equal) shall be provided as approved by the Engineer.

PART 3- EXECUTION

3.01 NOTIFICATION AND STOPPAGE OF WORK:

- A. The Engineer will notify the Contractor in writing of any non-compliance with the provisions of the Order of Conditions. The Contractor shall, after receipt of such notice, immediately take corrective action. Such notice, when delivered to the Contractor or his authorized representative at the site of the work, shall be deemed sufficient for the purpose. If the Contractor fails to act promptly, the Owner may order stoppage of all or part of the work through the Engineer until satisfactory corrective action has been taken. No claim for an extension of time or for excess costs or damage incurred by the Contractor as a result of time lost due to any stop work orders shall be

made unless it was later determined that the Contractor was in compliance.

3.02 AREA OF CONSTRUCTION ACTIVITY:

- A. Insofar as possible, the Contractor shall confine his construction activities to those areas defined by the plans and specifications. All land resources within the project boundaries and outside the limits of permanent work performed under this contract shall be preserved in their present condition or be restored to a condition after completion of construction at least equal to that which existed prior to work under this contract.

3.03 PROTECTION OF WATER RESOURCES:

- A. The Contractor shall not pollute streams, lakes or reservoirs with fuels, oils, bitumens, calcium chloride, acids or other harmful materials. It is the Contractor's responsibility to comply with all applicable Federal, State, County and Municipal laws regarding pollution of rivers and streams.
- B. Special measures should be taken to insure against spillage of any pollutants into public waters.

3.05 PROTECTING AND MINIMIZING EXPOSED AREAS:

- A. The Contractor shall limit the area of land which is exposed and free from vegetation during construction. In areas where the period of exposure will be greater than two (2) months, temporary vegetation, mulching or other protective measures shall be provided as specified.
- B. The Contractor shall take account of the conditions of the soil where temporary cover crop will be used to insure that materials used for temporary vegetation are adaptive to the sediment control. Materials to be used for temporary vegetation shall be approved by the Engineer.

3.06 LOCATION OF STORAGE AREAS:

- A. The location of the Contractor's storage areas for equipment and/or materials shall be upon cleared portions of the job site or areas to be cleared as a part of this project, and shall require written approval of the Engineer. Plans showing storage facilities for equipment and materials shall be submitted for approval of the Engineer.
- B. No excavated materials or materials used in backfill operations shall be deposited within a minimum distance of one hundred (100) feet of any watercourse or any drainage facility. Adequate measures for erosion and sediment control such as the placement of baled straw around the downstream perimeter of stockpiles shall be employed to protect any downstream areas from siltation.
- C. There shall be no storage of equipment or materials in areas designated as wetlands.

- D. The Engineer may designate a particular area or areas where the Contractor may store materials used in his operations.
- E. Storage areas in cross-country locations shall be restored to pre-construction conditions with the planting of native species of trees and shrubs.

3.07 PROTECTION OF LANDSCAPE:

- A. The Contractor shall not deface, injure, or destroy trees or shrubs nor remove or cut them without written authority from the Owner. No ropes, cables, or guys shall be fastened to or attached to any existing nearby trees for anchorages unless specifically authorized by the Engineer. Excavating machinery and cranes shall be of suitable type and be operated with care to prevent injury to trees which are not to be removed, particularly overhanging branches and limbs. The Contractor shall, in any event, be responsible for any damage resulting from such use.
- B. Branches, limbs, and roots shall not be cut except by permission of the Engineer. All cutting shall be smoothly and neatly done without splitting or crushing. When there is unavoidable injury to branches, limbs and trunks of trees, the injured portions shall be neatly trimmed and covered with an application of grafting wax or tree healing paint as directed.
- C. Where, in the opinion of the Engineer, trees may possibly be defaced, bruised, injured, or otherwise damaged by the Contractor's equipment or by his blasting or other operations, the Engineer may require the Contractor to adequately protect such trees by placing boards, planks, poles or fencing around them. Any trees or landscape feature scarred or damaged by the Contractor's equipment or operations shall be restored as nearly as possible to its original condition at the expense of the Contractor. The Engineer will decide what method of restoration shall be used, and whether damaged trees shall be treated and healed or removed and disposed of under the provisions of Section 31 11 00, CLEARING AND GRUBBING.
- D. Cultivated hedges, shrubs, and plants which could be injured by the Contractor's operations shall be protected by suitable means or shall be dug up, balled and temporarily replanted and maintained. After construction operations have been substantially completed, they shall be replanted in their original positions and cared for until growth is re-established. If cultivated hedges, shrubs, and plants are injured to such a degree as to affect their growth or diminish their beauty or usefulness, they shall be replaced by items of a kind and quality at least equal to that existing at the start of the work.

3.08 CLEARING AND GRUBBING:

- A. The Contractor shall clear and grub only on the Owner's land or the Owner's easements, and only the area required for construction operations, as approved by the Engineer. Removal of mature trees (4-inches or greater DBH) will not be allowed on temporary

easements.

- B. The Contractor shall not remove trees in the Owner's temporary easements without permission of the Engineer.

3.09 DISCHARGE OF DEWATERING OPERATIONS:

- A. Any water that is pumped and discharged from the trench and/or excavation as part of the Contractor's water handling shall be filtered by an approved method prior to its discharge into a receiving water or drainage system.
- B. Under no circumstances shall the Contractor discharge water to the areas designated as wetlands. When constructing in a wetlands area, the Contractor shall discharge water from dewatering operations directly to the nearest drainage system, stream, or waterway after filtering by an approved method.
- C. The pumped water shall be filtered through filter fabric and baled hay, a vegetative filter strip or a vegetated channel to trap sediment occurring as a result of the construction operations. The vegetated channel shall be constructed such that the discharge flow rate shall not exceed a velocity of more than 1 foot per second. Accumulated sediment shall be cleared from the channel periodically.

3.10 DUST CONTROL:

- A. During the progress of the work, the Contractor shall conduct his operations and maintain the area of his activities, including sweeping and sprinkling of streets as necessary, to minimize creation and dispersion of dust. If the Engineer decides it is necessary to use calcium chloride for more effective dust control, the Contractor shall furnish and spread the material, as directed. Calcium chloride shall be as specified under Section 01 14 19.16, DUST CONTROL.
- B. Calcium Chloride shall not be used for dust control within a drainage basin or in the vicinity of any source of potable water.

3.11 SEPARATION AND REPLACEMENT OF TOPSOIL:

- A. Topsoil shall be carefully removed where excavations are to be made, and separately stored to be used again as required. The topsoil shall be stored in an area acceptable to the Engineer and adequate measures shall be employed to prevent erosion of said material.

3.12 BALED STRAW:

- A. To trap sediment and to prevent sediment from clogging drainage systems, baled straw shall be used where shown on the drawings. Care shall be taken to keep the bales from breaking apart. The bales should be securely staked to prevent overturning, flotation, or displacement. All deposited sediment shall be removed periodically. Straw bales

shall not be placed within a waterway during construction of the pipeline crossing.

3.13 ERECTION AND MAINTENANCE OF SILT FENCE:

- A. Where indicated on the drawings or where required by the Engineer, the Contractor shall erect and maintain a temporary silt fence. In areas designated as wetlands, the Contractor shall line the limits of the construction easement with a silt fence. The silt fence shall be used specifically to contain sediment from runoff water and to minimize environmental damage caused by construction.

3.14 CATCH BASIN PROTECTION:

- A. Catch basin protection shall be used for every catch basin, shown on the plans or as required by the Engineer, to trap sediment and prevent it from clogging drainage systems and entering wetlands. Siltation sack shall be securely installed under the catch basin grate. Care shall be taken to keep the siltation sack from breaking apart or clogging. All deposited sediment shall be removed periodically and at times prior to predicted precipitation to allow free drainage flow. Prior to working in areas where catch basins are to be protected, each catch basin sump shall be cleaned of all debris and protected. The Contractor shall properly dispose of all debris at no additional cost to the Owner.
- B. All catch basin protection shall be removed by the Contractor after construction is complete.

3.15 STRAW WATTLES:

- A. The wattles will be placed in a shallow trench (2-3 inches deep) and staked in the ground using wooden stakes driven at 4-foot intervals. The wooden stakes will be placed at a minimum depth of 24-inches into the ground.
- B. The wattles shall be regularly inspected and before and after every forecasted major weather event. All deposited sediment shall be removed and not allowed to accumulate to the top of the wattles. Wattles damaged during construction shall be repaired or replaced as required by the Engineer at no additional cost to the Owner.
- C. The Contractor shall remove all wattles after construction is completed.

END OF SECTION

SECTION 01 74 13

CLEANING UP

PART 1 - GENERAL

1.01 DESCRIPTION:

The Contractor must employ at all times during the progress of its work adequate cleanup measures and safety precautions to prevent injuries to persons or damage to property. The Contractor shall immediately, upon request by the Engineer provide adequate material, equipment and labor to cleanup and make safe any and all areas deemed necessary by the Engineer.

1.02 RELATED WORK:

- A. Section 01 11 00 CONTROL OF WORK AND MATERIALS
- B. Section 01 57 19 ENVIRONMENTAL PROTECTION

PART 2 - PRODUCTS

Not applicable

PART 3 - EXECUTION

3.01 DAILY CLEANUP:

- A. The Contractor shall clean up, at least daily, all refuse, rubbish, scrap and surplus material, debris and unneeded construction equipment resulting from the construction operations and sweep the area. The site of the work and the adjacent areas affected thereby shall at all times present a neat, orderly and workmanlike appearance.
- B. Upon written notification by the Engineer, the Contractor shall within 24 hours clean up those areas, which in the Engineer's opinion are in violation of this section and the above referenced sections of the specifications.
- C. If in the opinion of the Engineer, the referenced areas are not satisfactorily cleaned up, all other work on the project shall stop until the cleanup is satisfactory.

3.02 MATERIAL OR DEBRIS IN DRAINAGE FACILITIES:

- A. Where material or debris has washed or flowed into or has been placed in existing watercourses, ditches, gutters, drains, pipes, structures, such material or debris shall be entirely removed and satisfactorily disposed of during progress of the work, and the ditches, channels, drains, pipes, structures, and work shall, upon completion of the work,

be left in a clean and neat condition.

3.03 REMOVAL OF TEMPORARY BUILDINGS, STRUCTURES AND EQUIPMENT:

- A. On or before completion of the work, the Contractor shall, unless otherwise specifically required or permitted in writing, tear down and remove all temporary buildings and structures it built; shall remove all temporary works, tools and machinery or other construction equipment it furnished; shall remove all rubbish from any grounds which it has occupied; shall remove silt fences and hay bales used for trapping sediment; and shall leave the roads and all parts of the property and adjacent property affected by its operations in a neat and satisfactory condition.

3.04 RESTORATION OF DAMAGED PROPERTY:

- A. The Contractor shall restore or replace, when and as required, any property damaged by its work, equipment or employees, to a condition at least equal to that existing immediately prior to the beginning of operations. To this end the Contractor shall do as required all necessary highway or driveway, walk and landscaping work. Materials, equipment, and methods for such restoration shall be as approved by the Engineer.

3.05 FINAL CLEANUP:

- A. Before acceptance by the Owner, the Contractor shall perform a final cleanup to bring the construction site to its original or specified condition. This cleanup shall include removing all trash and debris off of the premises. Before acceptance, the Engineer shall approve the condition of the site.

END OF SECTION

SECTION 01 78 00

PROJECT CLOSEOUT

PART 1 - GENERAL

1.01 WORK INCLUDED:

- A. This Section covers administrative and procedural requirements for closing out the project, including, but not limited to:
 - 1. Project as-built documents
 - 2. Checkout and Certification
 - 3. Final Cleaning
 - 4. Substantial Completion
 - 5. Closeout Procedures
 - 6. Final Completion
 - 7. Correction/Warranty Period
- B. Closeout checklist to be completed by the Engineer.

1.02 RELATED WORK:

- A. General Requirements in their entirety.
- B. Section 01 74 13, CLEANING UP
- C. Division 01 through Division 33.

1.03 AS-BUILT DOCUMENTS:

- A. Contractor shall maintain on site, separate from the documents used for construction, one set of the documents listed below, and as construction progresses, shall legibly record on these documents all changes made during construction.
 - 1. Contract Drawings.
 - 2. Specifications.
 - 3. Addenda.

4. Change Orders and other Modifications to the Contract.
5. Reviewed shop drawings, product data, and samples.
6. Written interpretations and clarifications.
7. Field Orders.
8. Field test reports properly verified.

B. The completed set of as-built documents shall be submitted to the Engineer with the final Application for Payment.

1.04 CHECKOUT AND CERTIFICATIONS:

A. Prior to checkout and certifications the following tasks shall be completed:

1. Construction shall be complete. For this purpose, completion of construction is defined as follows:
 - a. The Contractor has completed construction and erection of the work in conformance with the Contract Drawings and Specifications.
 - b. The Contractor has installed and adjusted operating equipment, systems, or facilities, as applicable, as defined by the manufacturers' erection, installation, operation and maintenance instructions.
2. All shop drawings shall have final approval.
3. All shop tests shall be complete and approved test results submitted to the Engineer.

1.05 START-UP AND TESTING:

A. Prior to start-up the following tasks shall be complete:

1. All checkout and certifications shall be satisfactorily completed,
2. All operations and maintenance manuals shall be approved,
3. All preliminary training by the manufacturer's representative shall be completed,
4. An approved start-up procedure shall be in place.

1.06 FINAL CLEANING:

A. Complete the following cleaning operations before requesting inspection for Certification

of Substantial Completion.

1. Clean the site, including landscape development areas of rubbish, litter and other foreign substances. Sweep paved areas broom clean; remove stains, spills and other foreign deposits. Rake grounds that are neither paved nor planted, to smooth, even textured surfaces.
2. Remove waste and surplus materials, rubbish, fencing equipment, temporary utilities and construction facilities from the site, unless otherwise required by the Engineer.
3. Comply with requirements of Section 01 74 13 CLEANING UP.

1.07 SUBSTANTIAL COMPLETION:

- A. Substantial Completion is officially defined in the General and Supplementary Conditions. The date of substantial completion will be certified by the Engineer. This date will not be certified until the following requirements have been satisfied by the Contractor:
1. All Contract requirements are coordinated into a fully operational system. All individual units of equipment and treatment are fully operative and performing at specified efficiencies. Where efficiencies are not specified, performance shall meet acceptable standards for the particular unit.
 2. All field tests have been satisfactorily completed and reports forwarded to the Engineer.
 3. All final training has been completed by the manufacturers' representatives.
 4. All spare parts and lubricants have been satisfactorily delivered to the Owner. Spare parts are for the exclusive use of the Owner when the facility has been turned over. Contractor is responsible for all maintenance and repair materials required until the facility is accepted by the Owner.

1.08 CLOSEOUT PROCEDURES:

- A. Submit written certification that Contract Documents have been reviewed, Work has been inspected, and is complete in accordance with Contract Documents and ready for Engineer's and Owner's inspection.
- B. Accompany Engineer and Owner on inspection to verify conformance with the Contract Documents. Prepare a punch list of work items that have been determined by inspection to not conform to Contract Documents. Punch list items shall include work items that are missing, incomplete, damaged, incorrect items, or improperly installed or constructed. The Contractor shall correct the punch list deficiencies by re-work, modifications, or replacement, as appropriate, until the items conform to the Contract Documents. The

initial punch list shall be produced by the Contractor, with copies to the Engineer and Owner. When the Contractor has reduced the number of deficient items to a reasonable level, the Engineer will develop a definitive punch list for the use of the Contractor.

- C. Provide submittals to Engineer that are required by governing or other authorities.
- D. Submit final Application for Payment identifying total adjusted Contract Sum, previous payments, and sum remaining due. The Contractor shall submit the following documents with or prior to Final Application for Payment: Set of as-built documents, Contract Completion and Acceptance Certificate, Consent of Surety to Final Payment, Release and Waiver of Liens and Claims (SECTION 01 78 00 – ATT. A), Affidavit of Payment of Debts and Claims, and remaining releases, waivers, warranties/guarantees, and all other data required by the Contract Documents.

1.09 FINAL COMPLETION:

- A. Prior to final completion, the following tasks shall be completed:
 - 1. All items in the punch list shall be completed.
 - 2. All Contract closeout documentation shall be submitted to and accepted by the Engineer.

1.10 CORRECTION/WARRANTY PERIOD:

- A. During the correction period, the Contractor shall correct all deficiencies in equipment and materials.
- B. During the warranty period, the Contractor shall perform all corrective work on warranty deficiencies.
- C. Corrective work will be identified by the Engineer or Owner, as appropriate. The Contractor will be notified of the item(s) requiring corrective work.
- D. The Contractor shall begin work on all corrective work within ten days of being notified of the deficiency by the Engineer and shall then work continuously until the deficiency is corrected. Upon completion of the corrective work, the Contractor shall submit a letter report to the Engineer describing the deficiency and the corrective action that was taken.
- E. The Contractor shall coordinate all corrective work with the Engineer and/or the Owner.

1.11 COMPLETION CHECKLIST:

- A. The Project Completion Checklist, which follows, shall be completed as the project nears completion. When the project has been fully completed, Final Payment can be approved.

PROJECT COMPLETION CHECKLIST

Owner _____ Job No.

Project

As part of the project closeout, all items listed below must be checked off as being complete or otherwise accounted for. The person verifying completion of the item shall list the completion date and his/her initials.

Project Closeout Checklist		
	Date Completion Verified	Verified by
AS-BUILT DOCUMENTS HANDED OVER		
1. Contract Drawings		
2. Specifications		
3. Addenda		
4. Change Orders/Contract Modifications		
5. Reviewed Shop Drawings, Product Data and Samples		
6. Written Interpretations/Clarifications		
7. Field Orders		
8. Field Test Reports		
EQUIPMENT CHECKOUT AND CERTIFICATIONS		
1. Construction Complete per Drawings/Specifications		
2. Equipment Installed and Adjusted		
3. All Shop Drawings have Final Approval		
4. All Shop Tests Complete and Results Submitted		

Project Closeout Checklist		
	Date Completion Verified	Verified By
START-UP AND TESTING		
1. All Checkout and Certifications Complete		
2. All O&M Manuals Approved		
3. All Preliminary Training by Manufacturers Rep. Completed		
FINAL CLEANING		
1. All Construction Facilities Removed		
2. All Construction Debris Removed		
3. All Areas Swept/Cleared		
SUBSTANTIAL COMPLETION		
1. All Items Coordinated Into a Fully Operational System		
2. All Equipment Units Operational at Specified Efficiencies		
3. All Field Tests Completed and Reports Submitted		
4. All Final Training by Manufacturer's Rep. Completed		
5. All Spare Parts and Lubricants Provided		
CLOSEOUT PROCEDURES		
1. Written Certification Submitted that Work is Ready for Owner & Engineer Inspector		
2. Inspection by Owner, Engineer, Contractor completed		
3. Punch List of Nonconforming Items Prepared		
4. Documents Required by Governing or Other Authorities Submitted (List Them)		
5. Final Application for Payment Received		
6. Contract Completion and Acceptance Certificate Submittal		
7. Consent of Surety to Final Payment Submittal		
8. Release and Waiver of Liens and Claims Submitted		
9. Affidavit of Payment of Debts and Claims Submitted		

Project Closeout Checklist

	Date Completion Verified	Verified By
10. Warranties/Guarantees Submitted		
11. Other Required Releases and Waivers Submitted (List Them)		
12. Permits Submitted (List Them)		
13. Weekly Payrolls Submitted as Required by Law		
FINAL COMPLETION		
1. All Items in Punch List Completed		
2. All Other Required Documentation Submitted (List It)		
CORRECTION/WARRANTY PERIOD		
1. Correction Period Start Date: _____ End Date: _____		
2. Specific Warranties Provided		
<p align="center"><u>Item</u> <u>Warranty Duration</u></p>		

Full name of persons signing their initials on this checklist:

END OF SECTION

Document2

SECTION 01 78 39

PROJECT AS-BUILT RECORD DRAWINGS

PART 1 - GENERAL

1.01 WORK INCLUDED:

This Section covers the Contractors As-Built Record drawings for the project. The As-Built Record drawings for the project shall include, but are not limited to:

A. The Contractors construction coordination drawings for all the project disciplines. The Contractors construction coordination drawings for the project disciplines shall be submitted to the Engineer prior to Construction of the said discipline. The Contractors construction coordination drawings for the project disciplines shall include but are not limited to the following:

1. Architectural
2. Civil
3. Structural
4. Electrical
5. Mechanical
6. Plumbing
7. Process
8. Instrumentation

B. Draft Record Documents Review

Upon completion of the project construction the Contractor shall submit a complete copy of 24- by 36-inch Record Drawings to the Owner and the Engineer for review. The Owner and the Engineer shall jointly review the Record Drawings and provide comments to the Contractor. The Contractor shall modify the Record Drawings as necessary based on the comments provided by the Owner and the Engineer.

C. Final Record Documents

Upon incorporation and acceptance of the Draft Record Drawings comments from the Owner and the Engineer, the Contractor shall submit the Final Record Drawings and documentation. The Contractor shall submit two sets of 24- by 36-inch Record Drawings to the Owner and an additional two sets of 24- by 36-inch Record Drawings to the Engineer for their records. The Contractor shall also submit to the Engineer a minimum 20 gigabyte flash drive with the electronic Record Drawing files. The electronic Record Drawing files shall be obtained from the Owner (the Engineer shall provide on behalf of the Owner if the Engineer was the project designer) and developed in AutoCAD 2010/Revit 2017 (or later) and the submittal shall include the Final AutoCAD DWG/Revit RVT file documents, drawing line

types, blocks, etc. The actual version of AutoCAD/Revit shall be coordinated with the Engineer.

D. Pre- and Post-Construction Survey

The Contractor shall perform a pre- and post-construction survey of the entire project area. The topographic survey shall be performed by or under the supervision of and certified by a Registered Land Surveyor in the State of **Massachusetts**. The Contractor shall also submit to the Engineer a minimum 20 gigabyte flash drive with the electronic pre- and post-construction survey files. The Contractor shall send the electronic pre- and post-construction survey files to the Engineer which shall be developed in AutoCAD 2010/ Revit 2017 (or later) and the submittal shall include the Final AutoCAD DWG / Revit RVT file documents, drawing line types, blocks, etc. The actual version of AutoCAD / Revit shall be coordinated with the Engineer. The Contractor shall notify the Owner and Engineer at least 48-hours in advance of each survey.

1.02 RELATED WORK:

- A. General Requirements in their entirety.
- B. Division 02 through Division 33.

1.03 AS-BUILT DOCUMENTS:

- A. Contractor shall maintain on site, separate from the documents used for construction, one complete set of the documents listed below, and as construction progresses, shall legibly record on these documents all changes made during construction.
 - 1. Contract Drawings.
 - 2. Specifications.
 - 3. Addenda.
 - 4. Change Orders and other Modifications to the Contract.
 - 5. Reviewed shop drawings, product data, and samples.
 - 6. Written interpretations and clarifications.
 - 7. Field Orders.
 - 8. Field test reports properly verified.
- B. The completed set of documents shall include but are not limited to:
 - 1. Significant deviations of any nature made during construction.
- C. The completed set of as-built documents shall be submitted to the Engineer with the final Application for Payment.

PART 2 - MATERIALS

Not Used

PART 3 - EXECUTION

Not Used

END OF SECTION

SECTION 01 92 13

OPERATION AND MAINTENANCE MANUALS

PART 1 - GENERAL

1.01 SCOPE OF WORK:

- A. This section includes procedural requirements for compiling and submitting operation and maintenance data required to complete the project.

1.02 RELATED WORK:

- A. General Requirements in their entirety (Section 00 11 00 through Section 01 78 00)
- B. Individual Technical Specification Sections Specific for Operation and Maintenance Data.
- C. Section 01 33 23, SUBMITTALS

1.03 FORMAT:

- A. Prepare data in form of an instructional manual.
- B. Binders: Commercial quality, 8 ½- x 11-inch three-ring binders with hardback, washable, plastic covers; two inch maximum ring size. When multiple binders are used, correlate data into related, consistent groupings. Provide a table of contents in each binder.
- C. Cover: Identify each binder cover and spine with typed or printed title OPERATION AND MAINTENANCE INSTRUCTION; list title of Project facility; identify subject matter of contents.
- D. Arrange contents by systems under section numbers and sequence of Table of Contents.
- E. Provide tabbed flyleaf for each separate product and system, with typed description of product and major component parts of equipment.
- F. Text: Manufacturer's printed data, or typewritten data - on 20-pound paper.
- G. Drawings: Provide with reinforced punched, binder tab. Bind in with text; fold larger drawings to size of text pages.
- H. Submit certification that the data and drawings provided pertain exactly to the model, size, and series product and equipment installed in the work.
- I. All documents will be electronically scannable.
- J. All products, systems, and drawings must be cross-referenced with tag ID numbers.

K. The manual for each piece of equipment shall be a separate document with the following specific requirement:

1. Contents:

Table of Contents and Index

Brief description of each system and components

Starting and stopping procedures

Special operating instructions

Routine maintenance procedures

Manufacturer's printed operating and maintenance instructions, parts list, illustrations, and diagrams

One copy of each wiring diagram

One copy of each approved shop drawing and each Contractor's coordination and layout drawing

List of spare parts, manufacturer's price, and recommended quantity

Name, address and telephone number of local service representatives.

2. Material

Loose leaf on 60 pound, punched paper

Holes reinforced with plastic cloth or metal

Page size, 8 ½- x 11-inches

Diagrams, illustrations and attached foldouts as required, of original quality, reproduced by dry copy method

Covers: oil, moisture and wear resistant 9 x 12 size

1.04 QUALITY ASSURANCE:

A. Prepare instructions and data by personnel experienced in maintenance and operations of described products.

1.05 CONTENTS, EACH VOLUME (BINDER):

- A. Table of Contents: Provide title of Contract, schedule of products and systems, indexed to content of the volume. A listing of all relevant tag ID numbers for each volume shall be placed immediately after the Table of Contents.
- B. For each product or systems: List names, addresses, and telephone numbers of subcontractors and suppliers, including local source of suppliers and replacement parts.
- C. Product Data: Mark each sheet to clearly identify specific products and component parts, and data applicable to installation. Delete inapplicable information.
- D. Drawings: Supplement product data to illustrate relations of component parts of equipment and systems, to show control and flow diagrams.
- E. Text: As required to supplement product data, provide logical sequence of instructions for each procedure incorporating manufacturer's instructions.
- F. Warranties, Guarantees, and Bonds: Bind copy of each
- G. See O&M Manual Review Checklist at end of this specification section.

1.06 MANUAL FOR MATERIALS AND FINISHES:

- A. Building Products, Applied Materials, and Finishes: Include product data with catalog number, size composition, and color and texture designations. Provide information for re-ordering custom manufactured products.
- B. Instructions for Care and Maintenance: Include manufacturer's recommendations for cleaning agents and methods, precautions against detrimental agents and methods, and recommended schedule for cleaning and maintenance.
- C. Moisture Protection and Weather Exposed Products: Include product data listing applicable reference standards, chemical composition, and details of installation. Provide recommendations for inspections, maintenance, and repair.
- D. Additional Requirements: As specified in individual product specification sections.

1.07 MANUAL FOR EQUIPMENT AND SYSTEMS:

- A. Each Item of Equipment and Each System: Include description of unit or system and component parts. Identify function, normal operating characteristics and limiting conditions. Include performance curves, with engineering data and tests, and complete nomenclature and commercial number of replaceable parts.
- B. Data submitted on all equipment shall include complete maintenance instructions

(including preventive and corrective maintenance) and parts lists in sufficient detail to facilitate ordering replacements.

- C. All products, systems, equipment, electrical wiring, instrumentation wiring, personnel protection systems wiring, presented in this manual will have tag numbers corresponding to contract drawings and specifications. In the event, numbers do not exist; the Engineer will specify a series of numbers.
- D. Panelboard Circuit Directories: Provide electrical service characteristics, controls and communications.
- E. Include color-coded wiring diagrams as installed.
- F. Operating Procedures: Include start-up, break-in, and routine normal operating instructions and sequence. Include regulation, control, stopping, shutdown, and emergency instructions. Include summer, winter and any special operating instructions.
- G. Provide servicing and lubrication schedule, and list of lubricants required. Cross-reference lubricants to products offered by at least three major lubricant suppliers.
- H. Include manufacturer's printed operation and maintenance instructions.
- I. Include sequence of operation by controls manufacturer.
- J. Provide original manufacturer's parts list, illustrations, assembly drawings, and diagrams required for maintenance.
- K. Provide control diagrams by controls manufacturer as installed.
- L. Provide Contractor's coordination drawings, with color-coded piping diagrams as installed.
- M. Provide charts of valve tag numbers, with location and function of each valve, keyed to flow and control diagrams.
- N. Provide list of original manufacturer's spare parts, current prices, and recommended quantities to be maintained in storage.
- O. Include test and balancing reports, calibration data, alignment records, and other information.
- P. Additional Requirements: as specified in individual product specification sections.
- Q. Provide a listing in table of Contents for design data with tabbed flysheet and space for insertion of data.
- R. Incorporation of all Physical Checkout information obtained through the field-

testing and correction phases of the Work. Input must be specific to the actions and information obtained during those phases.

1.08 SUBMITTALS:

- A. Submit draft and final copies of operation and maintenance manuals.

PART 2 – PRODUCTS

Not used.

PART 3 – EXECUTION

Not used.

**OPERATION AND MAINTENANCE MANUAL
REVIEW CHECKLIST**

1. Name, address, telephone/fax number of the manufacturer
2. Name, address, contact name, telephone/fax of local representative
3. Name, address, telephone/fax number of the contractor
4. Exploded view/general arrangement of materials of construction
5. Description of operation/operating principal
6. Project specific Operating parameters
7. Troubleshooting checklist
8. Recommended spare parts list with prices, and ordering instructions
9. Model number and the serial number of the model provided
10. Routine Maintenance instructions/service instructions with recommended Intervals
11. Assembly and disassembly instructions
12. Recommended lubricates and lubrication schedule.
13. Approved copies of Shop Drawings are to be included in the manual
14. Warranty information

Reviewed By: _____
Weston & Sampson Engineers

Date: _____

END OF SECTION

SECTION 02 41 13

SELECTIVE SITE DEMOLITION

PART 1 - GENERAL

1.01 SCOPE OF WORK:

- A. Work under this Section shall consist of the careful removal, storage for reuse, transportation off-site, or demolition, of all structures and site features encountered or noted to be removed or abandoned to a minimum of three feet below finished grade, and the removal and disposal of all materials not called for to be reused or salvaged, in accordance with the contract drawings, these specifications, and Engineer's requirements. Provide all labor, equipment, materials and transportation necessary to complete the work.
- B. Items plan referenced to be removed and stored shall be carefully removed and stored on site in a manner and location designated by the Engineer for reinstallation later as shown on the plans or as indicated by the Engineer.
- C. Items plan referenced, or as indicated by the Engineer to be removed and disposed of shall be removed from the site and properly and legally disposed of by the Contractor.
- D. Items indicated on the contract drawings or in the specifications to be removed and salvaged, or other items required to be removed by the Engineer, shall be transported to a municipal storage facility, located within the Town confines, and unloaded and stacked as required by the Engineer.
- E. Items indicated on the contract drawings or in the specification to be removed and reset shall be carefully removed and reset in the same location as existing according to the specification and details.
- F. The following scope describes the general work/demolition requirements of this Section.
 - 1. Cement concrete and bituminous concrete pavements.
 - 2. Curbing
 - 3. Wood fiber mulch surfacing
 - 4. Chain link fencing and footings complete.
 - 5. Swings & play equipment

6. Other features as indicated on the drawings.

1.02 PROTECTION:

- A. The Contractor shall assume complete responsibility and liability for the safety and structural integrity of all work and utilities to remain during demolition.
- B. Provide safeguards including, but not limited to, warning signs, barricades, temporary fences, warning lights and other items required for protection of personnel and the general public during performance of all work.
- C. All features related to protection shall be maintained until that work has been completed to the point when such safeguards are no longer required.

1.03 SPECIAL REQUIREMENTS:

- A. The Contractor shall salvage items label to be demolished and transport these to the a location designated by the Owner, unless these are called for to be reused or required by the Engineer to be disposed of.
- B. Install erosion controls to protect adjacent areas from eroded materials likely to enter wetlands, resource areas, or drainage ways/systems, downstream of areas disturbed by work activities.
- C. Where items to be demolished are located within or adjacent to pavements to remain, the Contractor shall make provisions to protect that pavement to remain. Cut concrete pavement back to score line and cut bituminous concrete pavement back far enough so as not to allow disturbance to base course materials. Pavements damaged as a result of Contractor activities shall be replaced to the extent determined by the Engineer at no additional cost to the Owner.

PART 2 - PRODUCTS

2.01 BACKFILL:

- A. The Contractor shall provide suitable backfill as specified under Section 31 23 00 of these Specifications, to fill voids left by removal or abandonment of site features, and shall provide all pipe cap ends, mortar, brick and other material needed to cap off or plug pipes of various sizes and kinds.
- B. Suitable materials shall be used as base course fill and topsoil to the depth as specified herein. Restore disturbed areas with similar materials blended to match the line and grades of adjacent surfaces.

2.02 TEMPORARY FENCE:

- A. The work under these Items shall conform to the relevant provisions of section 644 of the MassDOT standard specifications.
- B. The work shall include temporary installation of chain link fence around the perimeter of the work limits where shown on the plans, and as required by the Engineer, and as Contractor sees fit to protect work.
- C. Temporary fence shall consist of 6 foot high chain link fence anchored into a base that is both stable and movable to allow access and adjustment as needed. Reclaimed existing fence fabric and materials may be used with the approval of the Engineer. The Contractor shall submit a shop drawing to the Engineer for approval prior to installation.

PART 3 - EXECUTION

3.01 SALVAGEABLE MATERIAL:

- A. Frames, grates and other salvageable material shall be carefully removed to minimize damage and stored for later reuse, transport, or removal from site.

3.02 ABANDONED STRUCTURES:

- A. All inlets and outlets shall be plugged with at least eight (8) inches of brick and mortar masonry. Upper portions of masonry structures shall be removed to a depth of three feet. The bottoms of all structures shall be broken to allow drainage, and the structure shall be filled with suitable backfill material placed in six (6) inch layers and thoroughly compacted at each level.
- B. The Engineer shall review work related to abandoned structures before backfilling. Those items not reviewed before backfilling shall be uncovered and backfill procedures observed, at no expense to the Owner.

3.03 ABANDONED PIPES OR CONDUITS:

- A. Plug previously abandoned drainpipes encountered with masonry brick at least eight (8) inches in thickness.
- B. Abandon discontinued water supplies that are encountered during the execution of this contract in accordance with Owner requirements.
- C. Electrical conduits encountered and previously abandoned shall be capped or plugged.

END OF SECTION

SECTION 03 11 00

CONCRETE FORMWORK

PART 1 - GENERAL

1.01 WORK INCLUDED:

This section of the specifications covers the furnishing and installation of forms for cast-in-place concrete.

1.02 RELATED WORK:

- A. Section 03 21 00, CONCRETE REINFORCEMENT
- B. Section 03 30 00, CAST-IN-PLACE CONCRETE

1.03 REFERENCES:

The following standards form a part of this specification:

AMERICAN CONCRETE INSTITUTE (ACI)

ACI 301 Standard Specifications for Structural Concrete

ACI 347 Recommended Practices for Concrete Formwork

U.S. ARMY CORPS OF ENGINEERS (CE)

CE 03300 Cast-in-Place Concrete

PART 2 - PRODUCTS

2.01 MATERIALS:

- A. Forms for exterior and interior surfaces which will be exposed to view after the work is completed, whether such surfaces are painted or unpainted, shall be new plywood stock, steel, tempered masonite, or other materials which will provide smooth concrete surfaces without subsequent surface plastering. Plastic or plastic-faced forms shall not be used, except with the prior approval of the Engineer.
- B. Form ties shall be cone type or equal, with waterstop, which leaves no metal closer than 2-inches to finished face of concrete.
- C. Form release agent shall be a non-staining, non-yellowing, non-toxic liquid free from kerosene and resins of the type recommended by the manufacturer of the forming system being used such as EZ strip by L&M Construction Chemicals, Omaha, NB and "Magic

- Kote" by Symons Corp., Des Plaines, IL or approved equal.
- D. Where steel adjacent to vertical faces of forms cannot be otherwise secured, mortar doughnuts shall be used to prevent steel from lying too close to the finish vertical faces of the concrete.

PART 3 - EXECUTION

3.01 PREPARATION:

Surfaces of forms to be in contact with concrete shall be greased with nonstaining form release compound. Wetting will not be accepted as a substitute. Approval of the Engineer shall be obtained before use of coated materials or liners in lieu of form release compound, except as modified herein.

3.02 CONSTRUCTION:

- A. For concrete surfaces which will be visible after completion of the structure, painted or unpainted, the type and the precise location of form ties, nails joints between form members, and any other features which will leave a visible trace in the finished concrete, will be subject to the approval of the Engineer.
- B. Formwork shall be so constructed, braced, or tied that the formed surfaces of the concrete will be perfectly true, smooth, and to the dimensions shown on the drawings. All forms used for circular sections shall be true arcs as indicated on the drawings. Short chords will not be acceptable. Form line shall present an uninterrupted surface conforming to radii indicated on the drawings.
- C. Forms shall be sufficiently tight to prevent leakage of mortar, and when necessary shall have temporary openings as required for thorough cleaning, and as required for introduction of concrete to avoid excessive free fall. Panels damaged in stripping or otherwise shall not be reused.
- D. Unless otherwise noted on the design drawings, forms shall be filleted and chamfered at all sharp corners, and exposed edges with a 3/4-inch chamfer. Chamfer shall not be used where masonry or other material will subsequently be installed flush with one of the adjacent surfaces of the concrete. Where a wash or slope is indicated on the drawings no additional chamfer is required.

3.03 REMOVAL OF FORMS

- A. Except as otherwise specifically authorized by the Engineer, forms shall not be removed before the concrete has attained a strength of at least 30 percent of the ultimate strength prescribed by the design and not before reaching the following number of day-degrees [whichever is the longer]:

<u>Forms for</u>	<u>Day-Degree*</u>
Beams and Slabs	500

* Day-Degree: Total number of days times average daily air temperature at surface of concrete. For example, 5 days at a daily weighted average temperature of 60 deg F equals 300 day-degrees. Temperatures below 50 deg F are not to be considered in determining Day-Degree.

- B. Where beams, girder, columns, walls and similar vertical forms are adequately supported on shores, the side forms may be removed after 24 hours of cumulative curing time provided the side forms support no loads other than the lateral pressure of the plastic concrete. Cumulative curing time represents the sum of time intervals, not necessarily consecutive, during which the temperature of the air surrounding the concrete is above 50 deg. F in accordance with American Concrete Institute standards.
- C. Shoring shall not be removed until the concrete has attained at least 70 percent of the specified strength and sufficient strength to support safely its own weight and the construction live loads upon it.
- D. Forms shall be removed in such a manner as not to impair safety and serviceability of the structure. Concrete exposed by form removal shall have sufficient strength not to be damaged by the removal operation.

END OF SECTION

SECTION 03 21 00

CONCRETE REINFORCEMENT

PART 1 - GENERAL

1.01 WORK INCLUDED:

This section of the specification covers the furnishing and installation of reinforcement for cast-in-place concrete.

1.02 RELATED WORK:

- A. Section 03 11 00, CONCRETE FORMWORK
- B. Section 03 30 00, CAST-IN-PLACE CONCRETE

1.03 SYSTEM DESCRIPTION:

Materials and construction shall conform to ACI 318 and ACI 350 unless otherwise noted on the design drawings or modified herein.

1.04 SUBMITTALS: IN ACCORDANCE WITH REQUIREMENTS OF GENERAL SPECIFICATIONS, SUBMIT THE FOLLOWING:

- A. The Contractor shall furnish the Engineer with complete checked, reinforcing steel shop drawings and bar lists. Shop drawing shall include grade of steel used as well as splice lengths.
- B. Mill test reports shall accompany drawings. Fabrication shall not commence until the drawings and mill test reports have been released by the Engineer.
- C. When fiber reinforcement is used, contractor shall submit manufacturer's data confirming that material meets the specification.

1.05 REFERENCES:

- A. The following standards form a part of these specifications:

American Concrete Institute (ACI)

ACI 318 Building Code Requirements for Concrete

ACI 347 Recommended Practice for Concrete Formwork

ACI 350 Environmental Engineering Concrete Structures

ACI SP-66 ACI Detailing Manual

American Society for Testing and Materials (ASTM)

- ASTM A185 Standard Specification for Welded Steel Wire Fabric for Concrete Reinforcement
- ASTM A497 Specification for Welded Deformed Steel Wire Fabric for Concrete Reinforcement
- ASTM A615 Deformed Billet-Steel Bars for Concrete Reinforcement
- ASTM A775 Epoxy-coated Reinforcing Steel Bars
- ASTM A884 Epoxy-coated Welded Wire Fabric

American Welding Society (AWS)

- AWS 12.1 Recommended Practices for Welding Reinforcing Steel, Metal Inserts and Connections in Reinforced Concrete Construction

PART 2 - PRODUCTS

2.01 MATERIALS:

- A. Steel reinforcing bars shall conform to ASTM A615, Grade 60, and A775 if epoxy-coated bars are specified.
- B. Welded steel wire fabric shall conform to ASTM A185 or ASTM A497 and ASTM A884 if epoxy-coated fabric is specified. Gauge and spacing of wires shall be as indicated on the drawings.
- C. Reinforcing steel shall be detailed in accordance with ACI SP-66 modified as applicable to conform to ACI 350.
- D. Reinforcement shall be accurately formed to the dimensions indicated on the drawings. Bars shall be shipped to the site with bars of the same size and shape, fastened in bundles with securely wired-on metal identification tags listing both size and mark.
- E. Any bar showing cracks after bending shall be discarded.
- F. Steel failing to meet the requirements of this specification or the drawings will be rejected and shall be removed from the site immediately.

PART 3 - EXECUTION

3.01 STEEL INSTALLATION:

- A. Before being placed in position, reinforcement shall be thoroughly cleaned of loose mill and rust scale, dirt, and other coatings (including ice), that reduce or destroy bond. When there is a delay in depositing concrete after reinforcement is in place, bars shall be reinspected and cleaned as necessary.
- B. After forms have been oiled, but before concrete is placed, all steel shall be securely wired in the exact position called for, and shall be maintained in that position until all concrete is placed and compacted. Chair bars and supports shall be provided in a number and arrangement satisfactory to the Engineer.
- C. Concrete blocks having a minimum bearing area of 2-inches by 2-inches and equal in quality to that specified for the slab, shall be used for supporting reinforcing bars for slabs on grade. Wood blocks, stones, brick chips, etc., shall not be used to support reinforcement.
- D. Metal supports shall be of types that will not penetrate the surface of formwork or slab and which will not show through or stain surfaces that are to be exposed to view, painted or unpainted.
- E. Welding of reinforcing bars will be permitted only where permission of the Engineer has been obtained in advance. Such welding shall be performed only under conditions established by the Engineer, and in accordance with AWS 12.1.
- F. Reinforcement, which is to be exposed for a considerable length of time after having been placed, shall be painted with a heavy coat of cement grout, if required by the Engineer.

END OF SECTION

SECTION 03 30 00
CAST-IN-PLACE CONCRETE

PART 1 - GENERAL

1.01 WORK INCLUDED:

This Section covers all concrete and all related items necessary to place and finish the concrete work.

1.02 RELATED WORK:

- A. Section 03 11 00, CONCRETE FORMWORK
- B. Section 03 21 00, CONCRETE REINFORCEMENT
- C. Section 31 00 00, EARTHWORK
- D. Items furnished under other Sections and installed under this Section include, but are not limited to:

Items embedded in concrete, including anchors, sleeves, floor drains, castings, frames for hatches, angles, nosings, and other miscellaneous metals.

1.03 REFERENCES:

- A. The following standards form a part of these specifications:

American Concrete Institute (ACI)

- ACI 301 Structural Concrete for Buildings
- ACI 302 Recommended Practice for Concrete Floor and Slab Construction
- ACI 304 Recommended Practice for Measuring, Mixing, Transporting, and Replacing Concrete
- ACI 305 Recommended Practice for Hot Weather Concreting
- ACI 306 Recommended Practice for Cold Weather Concreting
- ACI 318 Building Code Requirements for Reinforced Concrete
- ACI 347 Recommended Practice for Concrete Formwork

ACI 350 Code Requirements for Environmental Engineering Concrete Structures

American Society for Testing and Materials (ASTM)

ASTM	C33	Concrete Aggregates
ASTM	C39	Compressive Strength of Cylindrical Concrete Specimens
ASTM	C42	Obtaining and Testing Drilled Cores and Sawed Beams of Concrete
ASTM	C87	Effect of Organic Impurities in Fine Aggregate on Strength of Mortar
ASTM	C94	Ready-Mixed Concrete
ASTM	C143	Standard Method for Slumps of Portland Cement Concrete
ASTM	C150	Portland Cement
ASTM	C171	Sheet Materials for Curing Concrete
ASTM	C231	Air Content of Freshly Mixed Concrete by the Pressure Method
ASTM	C260	Air-Entraining Admixtures for Concrete
ASTM	C309	Liquid Membrane-Forming Compounds for Curing Concrete
ASTM	C494	Chemical Admixtures for Concrete
ASTM	D1751	Preformed Expansion Joint Fillers for Concrete Paving and Structural Construction (Nonextruding and Resilient Bituminous Types)
ASTM	D1752	Preformed Sponge Rubber and Cork Expansion Joint Fillers for Concrete Paving and Structural Construction

1.04 SUBMITTALS: IN ACCORDANCE WITH REQUIREMENTS OF SECTION 01 33 23 SUBMITTALS, SUBMIT THE FOLLOWING:

- A. Shop drawings of the materials specified herein.
- B. Statement of materials constituting the design of mixes which satisfy the specified strength for each size aggregate as required by ASTM C94 shall be submitted to the Engineer within one week following award of the contract.
- C. Provide one copy of the "Certificate of Delivery" for each load of concrete as it arrives on the site, under the provisions of ASTM C94.

PART 2 - PRODUCTS

2.01 CONCRETE:

- A. Concrete conforming to the requirements listed below shall be used where indicated on the drawings. Unless otherwise indicated, concrete used as fill under foundations, and elsewhere approved by the Engineer, shall be the 3,000 psi mix.

TABLE

Minimum Comp. Strength at 28 days (psi)	Maximum Water/Cement ratio (gallons per bag of cement)*	Cement Factor: 94 lb. Bags per cubic yard minimum**
3000	0.59 (6.9)	5.5
4000	0.48 (5.6)	6.5
5000	0.40 (4.7)	7.4

* Based on air-entrained concrete. If non-air-entrained concrete is called for, the listed maximum water/cement ratios may be increased slightly, as approved by the Engineer. The water is the total water in the mix, including free water on the aggregate.

** These are minimum amounts; increase as necessary to meet mix requirements.

- B. Concrete shall conform to ASTM C94. One copy of the Certificate of Delivery required by ASTM C94 shall be delivered to the Engineer immediately upon arrival of each load of concrete at the site. The Contractor shall be responsible for the design of the concrete mixtures.
- C. Standard compression tests of all proposed mixes shall be made by the testing laboratory or other satisfactory evidence shall be presented that the design mixes will attain the minimum strengths listed on the design drawings or called for herein, within the limitations of the ACI Code. No concrete shall be delivered to the job site until the Engineer has approved the design mixes.
- D. All concrete (unless otherwise directed) shall contain an air-entraining agent. Air entrained concrete shall have an air content by volume of 3 to 6 percent for 1-1/2-inch aggregate and 4 to 8 percent for 3/4-inch aggregate. The air content shall be the responsibility of the testing laboratory and in accordance with ASTM C231.
- E. All concrete shall contain a mid-range water reducer to minimize cement and water content of the mix, at the specified slump, in accordance with ASTM C494.
- F. Slump for all concrete shall be from 3-inch to 4-inch, except for concrete using a superplasticizer, when the maximum slump shall be 8-inches. Any concrete having a slump greater than 4-inches (8-inches with superplasticizer) shall be promptly removed

from the site.

- G. No calcium chloride or admixtures containing calcium chloride shall be added to the concrete. No admixture other than those specified shall be used in concrete without the specific written permission of the Engineer in each case.
- H. No additional water, except for the amount indicated by the design mix shall be added to the concrete without the prior permission of the Engineer.

2.02 CEMENT:

- A. The cement shall be an approved brand of American manufactured Portland Cement, Type IIA conforming to ASTM C150. The brand name and type of cement proposed for use shall be submitted to the Engineer for approval immediately following award of contract. Only one color of cement, all of the same manufacture, shall be used for the work.
- B. When the use of high-early-strength Portland cement (Type IIIA) is permitted by the Engineer the same strength requirements shall apply, but the indicated strengths shall be attained in 7 days instead of 28 days.

2.03 ADMIXTURES:

- A. Air entraining agent shall be in accordance with ASTM C260.
- B. Water reducing agent shall be a mid-range water reducer meeting ASTM C494, Type A.
- C. Water reducing agent-retarder shall be in accordance with ASTM C494, Type D.
- D. Superplasticizer agent shall be in accordance with ASTM C494, Type F or Type G and contain no more than 0.1% chloride ions. Product may be plant added or field added based on the best application considering distance, temperature and time.

2.04 AGGREGATES:

- A. Except as otherwise noted, aggregate shall conform to the requirements of ASTM C33.
- B. Fine aggregate shall consist of washed inert natural sand conforming to the requirements of ASTM C33.
- C. Coarse aggregate shall consist of well-graded crushed stone or washed gravel conforming to the requirements of ASTM C33.
- D. The following designated sizes of aggregate shall be the maximum employed in concrete.

2-inch for mass concrete

1½-inch for reinforced sections 18-inch and over in thickness

3/4-inch for reinforced and unreinforced sections less than 18-inch thickness.

2.05 WATER:

Water for concrete shall be potable, free from injurious amounts of oil, acid, alkali, organic matter and other deleterious substances.

2.06 GROUT:

Grout shall be mixed in the proportions of one part Portland Cement to 2 parts sand, by volume. Only sufficient water shall be used to enable grout to barely hold its shape when squeezed into a ball in the hand. Aggregate for grout shall conform to the requirements of the reference specification for concrete. Prior approval of the Engineer shall be obtained for the use of proprietary grouts, and the instructions of the Engineer shall be followed in their use.

2.07 CURING MATERIALS:

- A. Curing compound shall be a curing/hardener compound such as Acurion by AntiHydro, Sikaguard Cure/Hard by Sika, Super Diamond Clear by Euclid or approved equal.
- B. Curing paper shall be a fiber-reinforced laminated Kraft bituminous product conforming to the requirements of ASTM C171.

2.08 JOINT FILLER:

- 1. Preformed joint filler strip shall conform to ASTM D1751 or D1752, having a thickness as indicated on the drawings.
- 2. Fillers shall be provided in pieces of the full thickness required. Use of multiple layers of thin pieces to make-up the full thickness will not be permitted.

2.09 JOINT SEALANT:

Joint sealant for construction and control joints shall be a two-part polysulfide base sealant conforming to Thiokol's Building Trade Performance Specification, Class A (self-leveling), Type II (hardness: 35-45 Shore A).

PART 3 - EXECUTION

3.01 GENERAL:

Under no circumstances shall concrete that has set or partially set before placing be used; and no retempering of concrete or grout will be permitted.

3.02 PREPARATION:

- A. Before placing concrete, forms and the space to be occupied by the concrete shall be thoroughly cleaned, and reinforcing steel and embedded metal shall be free from dirt, oil, mill scale, loose rust, paint or other material which would tend to reduce the bond.
- B. Unless otherwise indicated, a moisture barrier shall be used under all slabs placed on the ground in accordance with ACI 302.1R. The moisture barrier shall be fungi-resistant and shall have a vapor permeance rating not exceeding 0.01 perms (Perms [grains/ft²*hr*in. Hg]) per ASTM F1249 or ASTM E96) and 10 mils thickness (49 lbs/MSF). The moisture barrier shall be a high-performance underslab vapor retarder made from polyethylene resins that exceed ASTM E1745, Class A. Sheets shall be lapped 6-inches at joints and sealed with 2-inch wide tape or as recommended by the manufacturer. The vapor barrier should have all laps, seams, penetrations and terminations sealed and should carry across footings.
- C. When no moisture barrier is used, the earth, concrete, masonry, or other water-permeable material against which concrete is to be placed shall be thoroughly saturated with water immediately before concrete is placed. No concrete shall be placed until the consolidation of the ground and the arrangement and details of forms and reinforcing have been inspected and approved by the Engineer.
- D. When joining fresh concrete to concrete which has attained full set, the latter shall be cleaned by chipping and washing off all dirt and scum and laitance. It then shall be moistened prior to placing new concrete.
- E. Concrete surfaces that act as a seat for structural members (other than those resting on grout) shall be troweled to an extremely flat and level surface. If necessary, such surfaces shall be ground off to achieve the required flatness and level.
- F. Fill concrete on top of concrete shall be placed in the locations indicated on the drawings or designated by the Engineer. Before fill concrete is placed, the following procedures shall be used to prepare surfaces; all dirt, scum and laitance shall be removed by chipping and washing. The clean, roughened base surface shall be saturated with water, but shall have no free water on the surface. A coat of 1:2 cement-sand grout, approximately 1/8-inch thick, shall be well scrubbed into the thoroughly dampened concrete base. The concrete fill shall be placed immediately, before grout has dried or set. Fill concrete shall be brought to the lines and grades shown on the drawings or approved by the Engineer.
- G. Concrete for thrust and anchor blocks shall be placed against undisturbed earth and wooden side forms shall be used to provide satisfactory lines and dimensions. Felt roofing paper shall be placed to protect joints. No concrete shall be placed so as to cover joints, bolts or nuts, or to interfere with the removal of the joints. Minimum bearing areas and dimensions shall be as shown on the drawings.

3.03 MIXING:

- A. Concrete shall be ready-mixed, or transit-mixed, as produced by equipment acceptable to the Engineer. No hand-mixing will be permitted. Adding water in controlled amounts

during the mixing cycle shall be done only with the express approval of, and in the presence of the Engineer.

- B. Ready-mix or transit-mixed concrete shall be transported to the site in watertight agitator or mixer trucks loaded not in excess of rated capacities for the respective conditions as stated on the nameplate. Discharge at the site shall be within 1-1/2 hours after cement was first introduced into the mix. Central mixed concrete shall be plant-mixed a minimum of 1-1/2 minutes per batch and then shall be truck-mixed or agitated a minimum of 8 minutes. Agitation shall begin immediately after the pre-mixed concrete is placed in the truck and shall continue without interruption until discharge. Transit-mixed concrete shall be mixed at mixing speed for at least 10 minutes immediately after charging the truck, followed by agitation without interruption until discharged.
- C. All central plant and rolling stock equipment and methods shall conform to the latest Truck Mixer and Agitator Standards of the Truck Mixer Manufacturers' Bureau of the National Ready-Mixed Concrete Association, as well as ACI 304 and ASTM C94.
- D. Attention is called to the importance of dispatching trucks from the batching plant so that they shall arrive at the site of the work just before the concrete is required, thus avoiding excessive mixing of concrete while waiting or delays in placing successive layers of concrete in the forms.

3.04 INSTALLATION/APPLICATION/ERECTION:

- A. Placing
 - 1. No concrete shall be placed by pumping methods without the prior written approval of the Engineer. Should the Contractor be allowed to place concrete by pumping methods, procedures, mix design of concrete, and all other precautions shall be in accordance with ACI 304.2R and as approved by the Engineer.
 - 2. Concrete shall be placed in alternate areas, as defined by the construction and control joints indicated on the design drawings. A minimum of 3 days shall elapse between placement of adjacent sections.
 - 3. Segregation of the concrete shall be prevented during handling; should any segregation occur, the concrete shall be remixed before it is placed. Concrete shall be placed in the forms in horizontal layers not over 1 to 2 feet thick. Concrete shall not be allowed to drop freely more than 4 feet. If the free drop to the point of placement must exceed 4 feet, the Contractor shall obtain the approval of the Engineer for the proposed method of depositing the concrete. The concrete shall not be required to flow over distances greater than 3 feet in any direction in the forms or on the ground, unless otherwise permitted by the Engineer.
 - 4. Unless otherwise noted, the work begun on any day shall be completed in daylight of the same day.

5. "Cold Joints" are to be avoided, but if they occur, they are to be treated as bonded construction joints.
6. Chutes for conveying concrete shall be of U-shaped design and sized to insure a continuous flow of concrete. Flat (coal) chutes shall not be employed. Chutes shall be metal or metal-lined, and each section shall have approximately the same slope. The slope shall not be less than 25 nor more than 45 degrees and shall be such as to prevent segregation of the ingredients. The discharge end of the chute shall be provided with a baffle plate or spout to prevent segregation. If the discharge end of the chute is more than 5 feet above the surface of the concrete in the forms, a spout shall be used and the lower end maintained as near the surface of deposit as practicable. When the operation is intermittent, the chute shall discharge into a hopper. Chutes shall be thoroughly cleaned before and after each run, and the debris and any water shall be discharged outside the forms. Concrete shall not be allowed to flow horizontally more than 5 feet.
7. Concrete during and immediately after depositing shall be thoroughly compacted by means of suitable tools. Internal type mechanical vibrators shall be employed to produce the required quality of finish. Vibration shall be done by experienced operators under close supervision and shall be carried on long enough to produce homogeneity and optimum consolidation without permitting segregation of the solid constituents or "pumping" or migration of air. All vibrators shall be supplemented by proper wooden spade puddling adjacent to forms to remove included bubbles and honeycomb. This is essential for the top lifts of walls. All vibrators shall travel at least 10,000 rpm and be of adequate capacity. At least one vibrator shall be used for every 10 cubic yards of concrete per hour. In addition, one spare vibrator in operating condition shall be on the site.
8. Concrete slabs on the ground shall be well-tamped into place and foundation material shall be wet, tamped, and rolled until thoroughly compacted prior to placing concrete.
9. Concrete shall be deposited continuously in layers of such thickness that no concrete will be deposited on concrete that has hardened sufficiently to cause the formation of seams and planes of weakness within the section. If a section cannot be placed continuously, construction joints may be located at points as provided for in the drawings or approved by the Engineer.
10. Chutes, hoppers, spouts, adjacent work, etc., shall be thoroughly cleaned before and after each run, and the water and debris shall not be discharged inside the form.

B. Concrete Placing During Cold Weather

1. Concrete shall not be placed on frozen ground, and no frozen material or material containing ice shall be used. Materials for concrete shall be heated when concrete is mixed, placed, or cured when the mean daily temperature is below 40°F, or is expected to fall to below 40°F, within 72 hours, and the concrete after placing shall

be protected by covering, heat, or both. No accelerant shall be used to prevent freezing.

2. The temperature of concrete surfaces shall not be permitted to drop below 50°F. for at least 7 days after placement of the concrete.
3. All details of Contractor's handling and protecting of concrete during freezing weather shall be subject to the approval and direction of the Engineer. All procedures shall be in accordance with provisions of ACI 306.

C. Concrete Placing During Hot Weather

1. Concrete just placed shall be protected from the direct rays of the sun and the forms and reinforcement just prior to placing shall be sprinkled with cold water. The Contractor shall make every effort to minimize delays that will result in excessive mixing of the concrete after arrival on the job.
2. During periods of excessively hot weather (90°F, or above) ingredients in the concrete shall be cooled insofar as possible and cold mixing water shall be used to maintain the temperature of the concrete at permissible levels all in accordance with the provisions of ACI 305. Any concrete with a temperature above 90°F, when ready for placement will not be acceptable, and will be rejected.
3. Temperature records shall be maintained throughout the period of hot weather giving air temperature, general weather conditions (calm, windy, clear, cloudy, etc.) and relative humidity. The record shall include checks on temperature of concrete as delivered and after placing in forms. Data should be correlated with the progress of the work so that conditions surrounding the construction of any part of the structure can be ascertained.

D. Pipes And Embedded Metals

1. Special care shall be taken to bring the concrete into solid contact with pipes and iron work embedded in the walls and floors, particularly underneath and around all pipes where a head of water exists, making watertight joints.
2. In general, such embedded items are not shown on the structural design drawings. Design drawings of the other trades shall be consulted for their location and details.
3. Anchor bolt location, size and details shall be verified with the equipment manufacturer's certified drawings before installation.
4. Anchor bolts, reglets, sleeves, edge angles and similar embedded items will be provided, delivered to the site under other Sections of the specification, for installation under this Section.
5. Where edge angles, etc., have nuts welded on to receive machine screws, the

threads of the nuts shall be protected from concrete, and the concrete shall be excluded from the space to be occupied by the screw, by the use of wood plugs or other effective means.

6. Inserts required for hanging mechanical and electrical items shall be provided and installed in the forms under the mechanical and electrical sections of the specification.
7. Should the Contractor be allowed to leave openings in the concrete for pipes or ironwork, to await the arrival of items that would delay the prosecution of the work, the openings shall be subject to the approval of the Engineer. Appropriate construction joints shall be provided. In filling any such openings with concrete, a mixture of 1: 1-1/2 : 3 shall be used and a watertight bond shall be secured between the old and new concrete.
8. In bolting miscellaneous items to concrete after the concrete has set, expansion bolts of an approved pattern and type shall be used. The Contractor shall submit to the Engineer, for approval, the types of expansion bolts. Expansion bolts shall not be used until they are approved.

E. Curing

1. Concrete curing shall be performed as specified in ACI 301 and as stated herein. All curing procedures shall have prior approval of the Engineer.
2. Concrete Floors

Concrete floors which are to receive paint, concrete fill, mortar setting beds, grout fill, or any other subsequent finish shall be cured by one of the following procedures immediately after completion of placement and finishing:

- a. Ponding or continuous sprinkling.
 - b. Application of absorptive mats or fabric kept continuously wet.
 - c. Application of sand kept continuously wet.
 - d. Application of waterproof sheet materials conforming to ASTM C171.
 - e. Application of curing compounds conforming to ASTM C309, if it can be demonstrated to the Engineer's satisfaction that the compound is applicable and that it will not prevent bonding of the subsequent finish to be received. Compound shall be placed at a rate of 200 square feet per gallon, in two applications perpendicular to each other.
3. Curing procedure shall be continued for at least 7 days.

- a. Moisture loss from surface placed against metal or wood forms shall be minimized by keeping forms wet until removal.
- b. Curing shall be continued for at least 7 days. When forms are removed during the curing period, surfaces shall be cured by spraying or by the use of a curing compound as previously specified.
- c. Surfaces shall be protected from traffic or damage until surfaces have hardened sufficiently. If necessary, 1/2-inch thick plywood sheets shall be used to protect the exposed surface.

F. Bracing And Supports

- 1. All concrete members shall be adequately and safely supported and braced until the permanent supports and braces are installed.
- 2. Backfilling against exterior walls shall not be done until supporting slabs are in place and have attained 70 percent of design strength, otherwise walls shall be braced against earth lateral pressure, using a system approved by the Engineer.
- 3. Backfilling against retaining walls shall not commence until the wall concrete has reached its 28-day strength.

G. Removing Forms And Supports

- 1. Removal of forms shall take place in accordance with ACI 347, Section 3.6. Except as otherwise specifically authorized by the Engineer, forms shall not be removed until the concrete has aged for the following number of day-degrees or attained 50 percent strength. (Day-degrees equals the total of number of days times the average daily air temperature at the surface of concrete. For example, 5 days at a daily average temperature of 60°F. equals 300 day-degrees.)

<u>Location</u>	<u>Day-Degrees</u>
Beams and Slabs	500
Walls and Vertical Surfaces	200

- 2. Shores under beams and slabs shall not be removed until the concrete has attained at least 70 percent of the specified cylinder strength and also sufficient strength to support safely its own weight and the construction loads upon it.

H. Patching

- 1. Defective concrete and honeycombed areas as determined by the Engineer shall be chipped down reasonably square and at least one-inch deep to sound concrete by means of hand chisels or pneumatic chipping hammers. Irregular voids or surface stones need not be removed if they are sound, free of laitance, and firmly imbedded

in the parent concrete, subject to Engineer's final inspection. If honeycomb exists around reinforcement, chip to provide a clear space at least 1-inch wide all around the steel. For areas less than 1-1/2 inches deep, the patch may be made following the procedure for filling form tie holes, described in the subsection below, using adequately dry (non-trowelable) mixtures to avoid sagging. Thicker repairs will require build-up in 1-inch layers on successive days. Unless otherwise indicated, thicker repairs shall be made with Vertipatch mortar mixture blended with Acryl-Set, both by Master Builders, Inc., Cleveland, Ohio, or approved equal.

2. For concrete areas exposed to serious abrasion and/or impact forces, the Engineer may order the use of grout with a non-shrink metallic aggregate (Embeco by Master Builders, Inc.; Ironite by Fox Industries, Madison, IL; or approved equal) as an additive in the proportions listed below:

Material	Small Patches		Large Formed Patches	
	Volumes	Weights	Volumes	Weights
Cement	1.0	1.0	1.0	1.0
Metal Aggregate	0.15	0.25	0.2	0.33
Sand	1.5	1.5	1.5	1.0
Pea Gravel	--	--	1.5	1.5

I. Finishing Of Formed Surfaces

1. All concrete that is to be left exposed to view shall be scraped to remove projecting imperfections left by voids in the forms.
2. In addition to scraping, exterior exposed concrete shall be covered with a cement-base plaster mix. The mix shall consist of Thoroseal Plastic Mix and Acryl 60, as manufactured by Standard Drywall Products, Miami, FL, or approved equal. It shall be mixed and applied in accordance with the manufacturer's recommendations.
3. To permit satisfactory finishing, forms shall be removed from the vertical faces of the concrete as early as is possible without damaging the surface. Immediately after stripping forms, any fins or projections left by the forms shall be chipped off, and the surfaces rubbed smooth.
4. Form tie holes and other voids and faults shall be patched. Voids shall be cleaned out, roughened, thoroughly wetted, coated with neat cement paste, and filled with mortar of cement and sand in the same proportions, materials, and color as used in the concrete. The surface of the patch shall be flush with the surrounding surface after finishing operations are complete. Surface shall be kept continuously damp until patches are firm enough to be rubbed without damage.
5. Rubbing shall be performed while the surface is wet using a carborundum or cement sand brick, to achieve a smooth uniform, even textured finish. Patched and chipped

areas shall be blended to match as closely as possible the appearance of the rest of the surface. No cement wash or plastering will be permitted, and no mortar shall be used except as required above.

6. Where finishing is performed before the end of the curing period, concrete shall under no circumstances be permitted to dry out, and shall be kept continuously moist from time of placing until end of curing period, or until curing membrane is applied.

J. Testing

1. The Contractor shall provide all field testing and inspection services, and shall pay for all such services. The Engineer shall approve the testing laboratory and shall inform the Contractor when samples are to be taken for testing. The Contractor shall forward all test results to the Engineer as soon as they are available.
 - a. The Testing Laboratory shall conform to the requirements of ASTM E-329 as modified in 780 CMR R1 in the MA State Building Code. The State Board of Building Regulations and Standards shall license them.
2. At least one slump test shall be performed from each truckload of concrete. The sample for slump shall be taken from the middle third of a truckload. Air content tests shall be made at the discretion of the Engineer. If the measured slump or air content falls outside the specified limits, a check test shall be made immediately on another portion of the same sample. In the event of a second failure, the concrete shall be considered to have failed the requirements of the specification and shall be immediately removed from the jobsite to be discarded.
3. The Contractor shall advise the Engineer of his readiness to proceed with concrete placement at least one working day prior to each placement. The Engineer will inspect the preparations for concrete, including the preparation of previously placed concrete, the reinforcing, and the alignment and tightness of formwork. No placement shall be made without the prior approval of the Engineer.
4. A minimum of four standard compression test cylinders shall be made and tested for each 100 cubic yards or fraction thereof for each type and design strength of concrete from each day's placement of concrete. One cylinder shall be tested at 7 days and two cylinders at 28 days. The fourth cylinder from each set shall be kept until the 28 day test report on the second and third cylinders in the same set has been received. The Engineer reserves the right to require test cylinders to be made for each truckload of concrete if the nature of the project or project experience indicates such additional tests are required for proper control of concrete quality; such tests will be at the Contractor's expense.
5. The strength level shall be considered satisfactory so long as the averages of all sets of three consecutive strength test results equal or exceed the specified strength f'_c ,

and no individual strength test (average of two cylinders) result falls below the specified strength f'_c by more than 500 psi.

6. In the event the average compressive strength of the two 28 day cylinders do not achieve the required level, the Engineer may elect to test the fourth cylinder immediately or test it after 56 days.

K. Failure To Meet Requirements

1. The Engineer shall have the right to reject concrete represented by low strength tests or to agree to further testing of the concrete. Rejected concrete shall be promptly removed and replaced with concrete conforming to the specification. The decision of the Engineer as to whether substandard concrete is to be accepted or rejected or additional tests shall be conducted shall be final. All direct and indirect costs associated with further curing and testing of the concrete shall be at the Contractor's expense. All costs associated with removing rejected concrete, placing new concrete, and conducting tests on new concrete shall be at the Contractor's expense.
2. If the Engineer agrees to consider further curing and/or testing of the concrete before making a final decision, the Contractor shall submit a detailed plan to the Engineer, including proposed criteria for acceptance of the concrete. The plan may include additional curing of the concrete, drilling and testing of cores, load testing of the structure, or a combination.
3. If additional curing is permitted before further inspection and testing, the Contractor shall provide any necessary materials and labor to further cure the suspect concrete.
4. If drilling and testing of cores is permitted, the Contractor shall be responsible for obtaining the cores, including provision of ladders, scaffolding, and such incidental equipment as may be required. If additional curing is permitted, cores shall be drilled after the curing period, and shall be in accordance with ASTM Methods C39 and C42. The Contractor shall repair all core holes to the satisfaction of the Engineer.
5. The burden of proof, including, but not limited to the work of cutting and testing the cores, inspection, evaluation, engineering, repair of the holes, or removal and replacement of the concrete in question, and all associated costs therefor, shall be at the expense of the Contractor.
6. If load testing of the concrete is permitted, and if not otherwise indicated, slabs or beams under load test shall be loaded with their own weights plus a superimposed load of 2 times the design live load. The load shall be applied uniformly over the portion being tested in the approved manner and left in position for 24 hours. The structure shall be considered satisfactory if deflection "D" in feet, at end of 24-hour period, does not exceed the following value:

D equals $0.001 (L \times L)/t$

in which "L" is span in feet, "t" is depth of slab, or beam in inches. If deflection exceeds "D" in the above formula, the concrete shall be considered faulty unless within 24 hours after removal of the load, the slab, or beam under test recovers at least 75 percent of the observed deflection.

7. If the suspect concrete still fails to meet specification requirements, the Engineer shall have the right to reject the concrete, have it removed and replaced, in accordance with paragraph 5 above, or to require mechanical strengthening of the concrete to satisfy project requirements. The Contractor shall submit a removal and replacement plan for review by the Engineer.

L. Test For Watertightness

1. All concrete shall be watertight against leakage or groundwater infiltration. Special care shall be taken in the construction joints and any noticeable leakage or seepage causing wet spots on the concrete walls or slabs shall be repaired by and at the expense of the Contractor and by methods approved by the Engineer.
2. All liquid holding concrete structures shall be tested for leakage before backfilling and after the concrete has attained the specified minimum 28-day design strength, as indicated by test cylinders.
3. The structure shall be filled with water to the overflow level, allowed to stand for at least 24-hours, and refilled to overflow to begin the test. After 72 hours, the liquid loss per 24 hour period shall be determined, either by measuring the amount required to refill the tank to overflow, by measuring the drop in water level, or by an equivalent procedure approved by the Engineer. Evaporative losses shall be calculated and deducted from the measured loss to determine net liquid loss (leakage). If the leakage per 24-hour period exceeds the allowable, the structure shall be repaired and retested until the leakage falls within the allowable limit.
4. For structures designed to hold water, one twentieth of one percent leakage will be allowed during a 24-hour period. No leakage (zero leakage) will be permitted for structures designed to hold liquid chemicals or fuels.
5. The Contractor shall pay all costs (including water) incurred in the testing for watertightness.
6. The Engineer shall be given a minimum notice of 48 hours prior to commencement of the leakage test.

END OF SECTION

DRY-PLACED BOULDERS

PART 1 - GENERAL

1.01 RELATED DOCUMENTS

- A. The General Documents, as listed in the Table of Contents, and applicable parts of Division 1, General Requirements shall be included in and made a part of this Section.
- B. Examine all Drawings and all other Sections of the Specifications for requirements therein affecting the work of this trade.

1.02 SCOPE OF WORK

- A. The work of this Section shall consist of sourcing, transporting and placing granite boulders as shown on the Drawings and as directed by the Owner's Representative. Please note, the Owner's Representative is working with the Town of Arlington to secure granite boulders from their stockpile. While this resource is not a guarantee, the contractor should consider it while bidding. The work includes, but is not limited to, the following boulder types:
 - 1. Rounded Boulders

1.03 RELATED WORK UNDER OTHER SECTIONS

- A. The following items of related work are specified and included in other Sections of the Specifications:
 - 1. Section 31 23 00, EXCAVATION BORROW AND BACKFILL

1.04 EXAMINATION OF CONDITIONS

- A. The Contractor shall fully inform themselves of existing conditions of the site before submitting their bid and shall be fully responsible for carrying out all site work required to fully and properly execute the work of the Contract, regardless of the conditions encountered in the actual work. No claim for extra compensation or extension of time will be allowed because actual conditions inconsistent with those assumed.
- B. Plans, surveys, measurements and dimensions under which the work is to be performed are believed to be correct to the best of the Owner's Representative's knowledge, but the Contractor shall have examined them for himself during the bidding period, as no allowance will be made for any errors or inaccuracies that may be found therein.

1.05 SCHEDULING

- A. The Contractor shall submit to the Owner's Representative, for approval by the Owner, a progress schedule for all work as specified herein.

1.06 QUALITY ASSURANCE

- A. Materials and methods of construction shall comply with the following standards:
 - 1. ASTM: American Society for Testing and Materials
 - 2. AASHTO - American Association of State Highway and Transportation Officials (tests or specifications). AASHTO or AASHO
 - 3. Massachusetts Department of Transportation (MassDOT) Standard Specifications for Highways and Bridges.
- B. Qualifications of Workers: Use adequate numbers of skilled workers who are trained in the necessary crafts and who are completely familiar with the specified requirements and methods needed for the proper performance of the work of this Section.
- C. Layout: After staking out the work, and before beginning final construction, obtain the Owner's Representative's approval for layout. Contractor shall make adjustments as determined by the Owner's Representative. Owner's Representative may make adjustments to layout as is required to meet existing and proposed conditions without additional cost to the contract price.

1.07 SUBMITTALS

- A. Samples of all new materials proposed for the project shall be submitted to the Owner's Representative for review. Size of the samples shall be as approved by the Owner's Representative.

PART 2 - MATERIALS

2.01 BOULDERS

- A. Approximately two (2) weeks prior to anticipated transport, the Contractor shall notify the Owner's Representative to field select each boulder to be reused. The Contractor shall coordinate with the Owner's Representative such that she/he is present while blocks are loaded onto trucks. Rough-cut boulders shall be of an approved size and shape with dimensions as noted below, in the amounts shown on the drawings:
 - 1. Rounded boulders shall range in minimum size from two (2) feet to four (4) feet in both diameter and height. Boulders shall be smooth and rounded in shape with no sharp corners or angular projections greater than fifteen (15) degrees. These will need to be furnished and installed by the Contractor.
- B. The Contractor should expect to handle each stone a minimum of three times: 1) to move from current location into classification piles, 2) to mock up in final location to ensure fit, and 3) to install in final location. In most cases it is expected that steps two and three are combined and fitting can be done in place, but the Contractor must be

aware the project calls for dealing with boulders that will need to be carefully placed for best fit.

- C. Boulders shall contain no sharp corners or angular projections, to a fifteen (15) degree angle maximum, and shall be field approved by the Owner's Representative.
- D. The Contractor shall notify the Owner's Representative when site preparation is complete. Spacing and location of the boulders shall be as shown on the plans or as required by the Owner's Representative. Preliminary placement of boulders shall be "dry" (without mortar). The Contractor shall adjust the boulder placement as required by the Owner's Representative. After the arrangement of boulders is approved by the Owner's Representative, the Contractor shall set the boulders into grade on a compacted gravel base as necessary to set the boulders in a stable position and to prevent future removal or displacement of the boulders.
- E. All boulders located on site and those retrieved shall be pressure-washed prior to installation. The Contractor shall pressure-wash all boulders again at the end of the Contract work, just prior to project completion. All boulders shall be cleaned free from marks or scars caused by construction equipment.

PART 3 - EXECUTION

3.01 INSTALLATION

- A. The installer shall examine previous work, related work, and conditions under which this work is to be performed and notify the Contractor in writing of all deficiencies and conditions detrimental to the proper completion of this work. Beginning work means installer accepts substrates, subgrades, previous work, and conditions.

END OF SECTION

SECTION 05 50 00

MISCELLANEOUS METALS

PART 1 - GENERAL

1.01 WORK INCLUDED:

- A. This section of the specification covers all miscellaneous metal items required for the work, except as specified elsewhere.
- B. All miscellaneous metalwork shall be fabricated as detailed or approved and shall be installed complete with all necessary anchors, anchor bolts, eye bolts, guides, bolts and other accessories.
- C. The work of this Section shall consist of all site improvements and related items as indicated on the Drawings and/or as specified herein and includes, but is not limited to, the following:
 - 1. Steel Edge

1.02 QUALITY ASSURANCE:

- A. The drawings show the character and extent of the work required, but do not attempt to show all methods, materials, and details of construction, fastening, etc. Supplementary parts customarily necessary to complete an item, though such parts are not definitely shown or specified, shall be included as part of the item.
- B. Details of construction of the various items shall be submitted on the shop drawings. High quality construction with a neat, finished, and workmanlike appearance will be required.
- C. The size and spacing of screws, connectors, anchors, and similar items, and the size and dimensions of metal items stated herein shall apply in general; specific sizes and spacing of fasteners and dimensions of metal items listed on the drawings shall take precedence.
- D. Items supplied hereunder which are required to be built into the concrete, masonry, etc., shall be delivered to the site at locations as required by the Owner or Owner's Representative, and as required by the overall construction schedule.
- E. Manufacturers of other products comparable in quality and type to those specified will be acceptable if satisfactory data on past performance and other required information is furnished by the Contractor, and if approved by the Owner's Representative.
- F. Color galvanized system shall be guaranteed by manufacturer for 15 years.
- G. Contractor shall submit an affidavit to Owner's Representative that materials used are protected from or will not be subject to galvanic action.

1.03 REFERENCES:

- A. The following standards from a part of these specifications, and indicate the minimum standards required:

American Institute of Steel Construction (AISC)

AISC Specification for Structural Steel Buildings

American Society for Testing and Materials (ASTM)

ASTM A36 Structural Steel

ASTM A53 Pipe, Steel, Black and Hot-Dipped Zinc-Coated Welded and Seamless

ASTM A123 Zinc (Hot-Dip-Galvanized) Coatings on Iron and Steel Products

ASTM A153 Zinc Coating (Hot-Dip) on Iron and Steel Hardware

ASTM A239 Test for Uniformity of Coating by the Preece Test (Copper Sulfate Dip) on Zinc-Coated (Galvanized) Iron or Steel Articles

ASTM A307 Carbon Steel Externally and Internally Threaded Standard Fasteners

ASTM A366 Steel, Carbon, Cold-Rolled Sheet, Commercial Quality

ASTM A525 Steel Sheet, Zinc-Coated (Galvanized) by the Hot-Dip Process, General Requirements

ASTM A569 Steel Carbon (0.15 Maximum Percent) Hot-Rolled Sheet and Strip, Commercial Quality

ASTM B221 Aluminum-Alloy Extruded Bars, Rods, Shapes and Tubes

ASTM B308 Aluminum-Alloy Standard Structural Shapes, Rolled or Extruded

ASTM C478 Precast Reinforced Concrete Manhole Sections

American Welding Society (AWS)

AWS D1.1 Structural Welding Code Steel

1.04 SUBMITTALS: IN ACCORDANCE WITH REQUIREMENTS OF GENERAL SPECIFICATIONS, SUBMIT THE FOLLOWING:

- A. At least thirty days prior to intended use, the Contractor shall provide the following samples and submittals for approval in conformance with requirements this specification. Do not order materials until Landscape Architect's approval of samples, certifications or test results have been attained. Delivered materials shall closely match the approved samples.
1. Shop Drawings: Submit three (3) copies of each detailed shop drawings for each item required to be fabricated or installed under work of this Section. Include plans, sections, and details as required to show completely materials, layout, jointing, clearances and connections for all items required. Shop drawings for handrails at stairs requiring accurate dimensional relationships to as-built construction shall be prepared following a review and confirmation of as-built measurements and conditions for areas scheduled to receive miscellaneous metal items. Submit shop drawings for the following:
 - a. Steel Edge
 2. Material Samples: Submit samples for each material for the following:
 - a. Steel Edge – submit one (1) sample
 3. Finishing Schedule: Submit a complete schedule outlining all items to be color finished under work of this Section together with a breakdown of surface preparation techniques and primer and color finish materials to be applied.
- B. The shop drawings shall be complete and checked, showing sizes, layout, method of assembly, fastenings, anchorage or connection with other work, finish, and coatings, etc. Shop drawings for aluminum work shall indicate alloys, temper and finish to be used.
- C. The Contractor shall certify that all dimensions are correct prior to fabrication.

PART 2 - PRODUCTS

2.01 MATERIALS:

F. STEEL EDGING

1. Steel edging shall be ¼” x 4” with steel spikes as manufactured by Sure-loc Edging, 494 E. 64th Street, Holland, MI 49423 or approved equal. Color shall be black.

PART 3 - EXECUTION

3.01 GALVANIZING:

- A. Hot-Dip Galvanizing:

1. Provide a coating for iron and steel fabrication applied by the hot-dip process. The galvanizing bath shall contain .05-.09% nickel. Immediately before galvanizing, the steel shall be immersed in a bath of zinc ammonium chloride. The use of the wet kettle process is prohibited. Comply with ASTM A-123 for fabricated products and ASTM A-153 for hardware. Provide thickness of galvanizing specified in referenced standards. Provide coating by Duncan galvanizing or approved equal.

B. Factory-Applied Primer Over Hot-Dip Galvanizing:

1. Provide a factory-applied polyamide epoxy coating primer, 2.0 mils dry film thickness minimum. Apply primer within 12 hours after galvanizing at the galvanizer's plant in a controlled environment meeting applicable environmental regulations or mechanically abrade to create a uniform surface profile of 1.0 – 2.0 mils, and as recommended by coating manufacturer. Provide primer coating by Duncan Galvanizing, Tnemec Co. or approved equal.

C. Factory Finish Over Primer And Hot-Dip Galvanizing:

1. Provide a factory-applied polyurethane color coating, 2.5 mils dry film thickness minimum. Apply coating at the galvanizer's plant or coating shop, immediately after application of the prime coat, in a controlled environment meeting applicable regulations, and as recommended by the coating manufacturer. Provide finish coating by Duncan Galvanizing, Tnemec Co. or approved equal.

- D. Items noted as "color galvanized" shall have an architecturally compatible factory finish formulated to be applied over galvanized members, suitable for use in harsh environments, and applied by the galvanizer at the factory or coating shop.

- E. The Contractor shall be responsible for determining if any fabricated items are not suitable to be hot-dip galvanized and shall notify the Owner's Representative in writing.

- F. Surfaces of metal to be galvanized shall be free from all dirt, grease, rust and moisture. Burrs and sharp projections shall be removed from edges, holes, etc., before galvanizing. Fabricated items shall be galvanized after fabrication.

3.02 WELDING OF STEEL:

Welding of steel shall be done in accordance with the AWS Code. Welds shall be continuous along entire line of contact, except where plug welding is noted. Exposed welds shall be ground smooth.

3.03 FABRICATION AND ERECTION:

- A. Metalwork shall be complete, with all necessary bolts, nuts, washers, anchors, plates, fastenings, and other fittings. To the extent possible, holes for attachment of blocking, clip

angles, etc. shall be shop punched. Where shop punching is impracticable, holes shall be field drilled. Burned holes will not be permitted.

- B. Material shall be straight, accurately fabricated with joints neatly framed, square, and well-riveted, bolted, or welded.
- C. Metalwork to receive hardware shall have all cutouts and attachments accurately made using the hardware itself or templates where necessary.
- D. Metalwork shall be accurately set and secured in position, with lines plumb and level and surfaces flush and square, or as otherwise required to conform to the structure as shown on the drawings.
- E. Wherever possible, all metalwork shall be built into the masonry work and shall have sufficient anchors, well- fastened. Anchors shall be welded to steelwork and shall be staggered where attached to structural shapes. Metal- work impracticable to set before masonry is built shall be anchored to it with approved expansion bolts set in solid masonry units or in concrete.
- F. Miscellaneous metalwork shall be plainly marked to indicate its location in the structure.

END OF SECTION

SECTION 06 10 00

ROUGH CARPENTRY

PART 1 - GENERAL

1.01 WORK INCLUDED:

- A. This Section covers tools, equipment, labor, and materials necessary to perform rough carpentry work complete and miscellaneous carpentry items not specified elsewhere including fasteners and supports.
- B. Nails, screws, bolts, anchors, brackets, and other hardware for fastening and securing items provided under this section of the specification shall be furnished under this section.

1.02 RELATED WORK:

- A. Section 03 30 00, CAST-IN-PLACE CONCRETE
- B. Section 06 20 00, FINISH CARPENTRY
- C. Section 31 50 00, SUPPORT OF EXCAVATION

1.03 SUBMITTALS: IN ACCORDANCE WITH REQUIREMENTS OF GENERAL SPECIFICATIONS, SUBMIT THE FOLLOWING:

Three sets of certificates of wood treatment upon delivery of treated wood product. Treated wood product shall bear appropriate American Wood Preservers Bureau (AWPB) quality mark.

1.04 DELIVERY:

Lumber, plywood, and other wood material shall be delivered to the job dry, and shall be protected from injury, dirt, dampness, and extreme changes of temperature and humidity at all times.

PART 2 - PRODUCTS

2.01 MATERIALS:

A. LUMBER:

1. The grades of all materials under this section shall be defined by the rules of the recognized associations of lumber manufacturers producing the material specified, but the maximum defects and blemishes permissible in any specified grades shall not exceed the limitations of the American Lumber Standards.

2. Lumber shall bear the grade and trademark of the association under whose rules it is produced, and a mark of mill identification. Lumber shall be of sound stock, thoroughly seasoned, kiln dried to a moisture content not exceeding 15 percent.
3. Exposed surfaces of wood which are to be painted shall be free from defects or blemishes that will show after the second coat of paint is applied.
4. All lumber for nailers, furring, and blocking shall be seasoned No. 1 Dimension of Common pine, fir, or spruce, S4S.
5. Framing Lumber for joists, rafters, plates, headers, stair stringers and carriages, and sleepers shall be Hem-Fir #1 with the following minimum properties:

$$E = 1.5 \times 10^6 \text{ PSI}$$

$$\text{Density} = 0.01736 \text{ lb/in.}^3$$

$$F_b = 1400 \text{ PSI}$$

$$F_v = 75 \text{ PSI}$$

$$F_c = 1050 \text{ PSI}$$

$$F_t = 800 \text{ PSI}$$

6. Studding shall be 2- inch x 4- inch Western or Eastern Species, Construction Grade, or KD Stud Grade Southern Yellow Pine or studgrade Spruce-pine-fir. Where two or more studs are nailed together, such assemblies may be No. 2 or Better Grade Southern Yellow Pine and stud grade Southern Yellow Pine.
7. Materials not specifically listed shall be of an accepted grade dictated by good practice.

B. WOOD PRESERVATION TREATMENT:

1. The nailers, blocking, sills, and similar items encased in or in contact with concrete, masonry, or the ground shall be pressure treated with a pentachlorophenol preservative solution. The pentachlorophenol shall meet the requirements of the American Wood-Preserver's Association, AWWA Standard P-8, "Standards for Oil-Borne Preservatives." The solvent carrier shall meet the requirements of AWWA Standard P-9 "Standard for Hydrocarbon Solvents for Oil-Borne Preservatives." The preservative solution shall be equivalent to five percent of pure pentachlorophenol.
2. The treatment shall be applied in accordance with AWWA Standard C-2 (lumber, timber, etc.), C-9 (plywood) or C-28 (lumber treated before laminating). Penetration of pentachlorophenol shall be determined using the penta check method, Section 5, AWWA Standard A-3. Retention of pentachlorophenol shall be a minimum of 0.40 pounds per cubic foot of wood for inground exposures. The treating company shall furnish a notarized certificate of treatment that indicates all pertinent details of the treatment.

3. Before the preservative treatment is applied, the lumber to be treated shall be sawed to exact lengths required, and bored ready for use in the work so far as practicable, in order to reduce to a minimum cutting or boring of lumber after treatment. Only lumber of the same kind and approximately the same size and seasoning shall be treated in any one charge. All surfaces of treated lumber cut after treatment shall receive two heavy brush coats of pentachlorophenol solution before the lumber is placed in the work.

C. WOOD FIRE RETARDANT TREATMENT:

1. Exposed wood blocking and sheeting shall receive fire-retardant treatment conforming to American Wood Preservers Association, AWPAC Standard C20 for lumber and AWPAC C27 for plywood.
2. Fire retardant treated lumber shall bear UL label and shall have UL Fire-Hazard Classification "FR-S", when tested in accordance with ASTM E84.
3. Material to receive interior grade fire-retardant treatment shall be pressure impregnated with "Dricon" fire-retardant chemicals manufactured by Hickson Corporation, Atlanta, Georgia, in accordance with manufacturer's instructions.

PART 3 - EXECUTION

3.01 CONSTRUCTION:

- A. Work shall be erected plumb, true and square.
- B. Coordinate delivery and erection of prefabricated components. Field applied items shall be installed in accordance with good trade practices. Cutting and carpentry for other trades shall be performed. Cut ends of lumber previously treated with preservative specified shall be brushcoated with the same material.
- C. Except as otherwise indicated on the design drawings, fasteners for roof nailers and for other wood members used as nailers or anchorage material shall be the equivalent of 1/2-inch diameter bolts at 2'-6" o.c. for 2-inch material, and 3/8-inch diameter bolts at 2'-0" o.c. for 1-inch material. Wood members in general shall be fastened to masonry with masonry nails, power-driven fasteners, or bolts in expansion shields, except where otherwise indicated.
- D. Minimum length of nails shall be twice the thickness of wood being fastened.
- E. Furring, blocking, nailers, and similar items shall be provided wherever required for the support, proper erection, fastening, or installation of carpentry or other materials, and as shown on the drawings.

END OF SECTION

SECTION 06 20 00

FINISH CARPENTRY

PART 1 - GENERAL

1.01 WORK INCLUDED:

- A. This section of the specification covers furnishing tools, equipment, labor and materials necessary to perform finish carpentry work (exterior and interior) complete, and miscellaneous carpentry items not specified elsewhere including fasteners and supports.
- B. Metal fasteners, plates, brackets, and accessories connected directly into woodwork shall be a part of this section of the specification. Nails, screws, bolts, anchors, brackets, and other similar hardware for fastening and securing woodwork and other items provided under this section of the specification shall be furnished under this section.

1.02 RELATED WORK:

- A. Section 06 10 00, ROUGH CARPENTRY

1.03 SUBMITTALS: IN ACCORDANCE WITH REQUIREMENTS OF GENERAL SPECIFICATIONS, SUBMIT THE FOLLOWING:

- A. Six sets of manufacturer's literature of the materials of this section shall be submitted to the Engineer for review.
- B. Three sets of samples of paneling shall be submitted to the Engineer for selection of colors.
- C. Three sets of certificate of wood treatment upon delivery of treated wood product. Treated wood product shall bear appropriate American Wood Preservers Bureau (AWPB) quality mark.

1.04 DELIVERY AND STORAGE:

Finish carpentry material shall be delivered to the job dry, and shall be protected from injury, dirt, dampness and extreme changes of temperature and humidity at all times. Doors, trim, and other prefinished material shall be completely wrapped as required to prevent injury during shipment and storage. Finish materials shall not be delivered until the building is heated and all masonry and other "wet" work has been completed and allowed to become thoroughly dry.

PART 2 - PRODUCTS

2.01 MATERIALS:

- A. The grades of all materials under this section shall be defined by the rules of the recognized associations of lumber manufacturers producing the material specified, but the maximum defects and blemishes permissible in any specified grades shall not exceed the limitations of the American Lumber Standards. Materials not specifically listed shall be of an accepted grade dictated by good practice.
- B. Lumber shall bear the grade and trademark of the association under whose rules it is produced, and a mark of mill identification. Finished woodwork shall be of sound stock, thoroughly seasoned, kiln dried to a moisture content not exceeding 12 percent.
- C. Finish carpentry and millwork, in general, shall comply with the following sections, as applicable, of the Architectural Woodwork Quality Standards, Guide Specifications and Quality Certification Program as published by the Architectural Woodwork Institutes for Material and Work of "Custom Grade":

Section 100	Lumber
Section 200	Plywood
Section 300	Trim
Section 400B	Architectural Cabinets (Laminate Clad)
Section 400C	Architectural Cabinets (Tops)
Section 600	Shelving

- D. WOOD FIRE RETARDANT TREATMENT:
 - 1. Exposed wood trim and sheathing shall receive fire-retardant treatment conforming to American Wood Preservers Association, AWPAC Standard C20 for lumber and AWPAC C27 for plywood.
 - 2. Fire retardant treated lumber shall bear UL label and shall have UL Fire-Hazard Classification "FR-S", when tested in accordance with ASTM E84.
 - 3. Material to receive interior grade fire-retardant treatment shall be pressure impregnated with "Dricon" fire-retardant chemicals manufactured by Hickson Corporation, Atlanta, Georgia, in accordance with manufacturer's instructions.

PART 3 - EXECUTION

3.01 CONSTRUCTION:

- A. Work shall be erected plumb, true and square. Finish work shall be accurately mitered or butted to meet in straight hairline joints, in accordance with the best commercial practice.
- B. All exterior wood trim shall be fully back primed prior to installation. Prime cut edges after installation and prior to application of additional wood members.

- C. Finish nails shall be used on all exposed trim. Galvanized nails shall be used on all exterior finish work.
- D. Minimum length of nails shall be twice the thickness of wood being fastened. Nail heads in finished work shall be sunk neatly with a nail set and the resulting hole filled with putty. Fasteners in items such as mouldings shall be concealed.
- E. Exposed surfaces of woodwork shall be machine sanded to an even, smooth surface, free of defects, blemishes, machine or tool marks, abrasions, dirt, smudges, or raised grain. Adequate protection shall be provided as necessary to prevent damage or staining of carpentry items.
- F. Woodwork abutting masonry or other finish materials shall be scribed and fitted as tightly to abutting material as is possible without damaging it.

END OF SECTION

SECTION 11 68 13

PLAYGROUND EQUIPMENT

PART 1 - GENERAL

1.01 SCOPE OF WORK

- A. Under the Base Bid, the Contractor is responsible for preparing all base materials, sub-grades all playground areas as well as adjacent site features. The playground equipment shall be as noted on the plans and herein or approved equal.
- B. Refer to Appendix A for manufacturer's data.

1.02 REFERENCE STANDARDS AND SPECIFICATIONS

- A. Playground equipment design, layout, and installation shall comply with the following standards and guidelines as applicable.
 - 1. CPSC - Consumer Product Safety Commission Guidelines for Playground Safety, latest edition.
 - 2. ASTM - American Society for Testing and Materials, Designation: F 1487, Standard Consumer Safety Performance Specification for Playground Equipment for Public Use, latest edition.
 - 3. ANSI - American National Standards Institute.
 - 4. AASHTO - American Association of State Highway and Transportation Officials (tests of specifications).
 - 5. MAAB - Massachusetts Architectural Access Board
- B. Requirements not specifically set forth herein, but required by the agencies listed in above shall be understood to be a requirement of this contract since these standards of quality and safety are established as the industry standard(s). Any conflicts between the agency standards and the contract documents shall be brought to the attention of the Owner's Representative, and unless otherwise required in writing, the agency standards shall be the minimum requirement to be followed.

1.03 SHOP DRAWINGS

- A. Prior to ordering, furnishing and/or installing the play equipment as required by the Contract Documents, the following shall be submitted to the Project

Representative for review and approval:

1. Certified product data, shop and fabrication drawings showing all important details of construction and dimensions showing the equipment, arrangement, footing spacing and lengths. Shop drawings shall stipulate and certify to compliance with all CPSC and ASTM standards and guidelines as applicable.
 2. Descriptive literature and technical specifications for all play equipment installations.
 3. Warranty certificates for all applicable play equipment features, components, hardware, finishes and other applicable items.
 4. In the event that it is impossible to conform to certain details of this specification due to differing manufacturing techniques or conventions, submit complete summary of all non-compliant components or elements.
- B. The Contractor shall submit complete manufacturer's shop drawings which shall include the horizontal layout and vertical alignment for the proposed custom equipment installation to the Owner's Representative for approval. No material may be ordered prior to receiving written approval from the Owner's Representative.

1.04 SAMPLES

- A. Submit the following samples in accordance with the provisions of the GENERAL CONDITIONS.
1. Submit samples and descriptive literature of all items specified in this Section, including treatments, finishes, colors, and test information.

1.05 QUALIFICATIONS

- A. Installer shall have a minimum of five (5) years experience with a minimum of fifteen (15) playground installations. References will be required.

PART 2 - MATERIALS

2.01 PLAYGROUND EQUIPMENT

- A. Play Equipment shall be manufactured by Landscape Structures, Inc. as represented by Brian Iofalla, M.E. O'Brien & Sons, Inc., 93 West Street, Medfield, MA 02052, 800-835-0056, or approved equal, Kompan Playgrounds, 930 Broadway, Tacoma, WA 984902 (800) 426-9788 or approved equal, and Berliner Seilfabrik Play Equipment Corporation, 96 Brookfield Oaks Drive, Suite 140, Greenville, SC, 1-864-627-3686, or approved equal.

B. Landscape Structures play equipment shall be as follows:

	Qty	Model Number	Description
PlayBooster® (5-12 years)			
Climbers W/Permalene Handholds			
	1	204176A	Flex Climber w/Permalene Handhold 8" Deck Diff attached to 72"Dk
	1	122914B	Loop Arch 56"Dk DB
	1	148434B	Loop Pole Perm Handholds 72"Dk DB
	1	203845A	Seeker Climber w/Permalene Handholds 32" Deck Diff Attached to 48"
	1	116246D	Step Ladder 72"Dk DB
	1	116249D	Vertical Ladder 64"Dk DB
Decks			
	2	122197A	90* Triangular Tenderdeck
	2	121948A	Kick Plate 8"Rise
	1	185852A	Transfer Step w/2 Handloops DB
	5	111231A	Triangular Tenderdeck
	2	119646A	Tri-Deck Extension
	1	121949A	Tri-Deck Kick Plate 8"Rise
Motion & More Fun			
	1	193176A	Boogie Board DB Only
	1	111357A	Chinning Bar Alum DB
	1	120901A	Grab Bar
	1	120902A	Handhold Leg Lift
	1	120818A	Playstructure Seat
Overhead Events			
	1	142890A	2"90* Horizontal Ladder DB Connected
Posts			
	1	111404G	100"Alum Post DB
	1	111404R	108"Steel Post DB 42" BURY
	4	111404E	116"Alum Post DB
	4	111404D	124"Alum Post DB
	1	111404C	132"Alum Post DB
	1	111404B	140"Alum Post DB
	1	111404N	140"Steel Post DB
	2	111404A	148"Alum Post DB
	1	111404M	148"Steel Post DB
	2	111404W	156"Steel Post DB
	1	111404H	92"Alum Post DB

Slides			
	1	148426A	Firepole Perm Handholds 48"Dk DB
	1	222708A	WhooshWinder Slide 72"Dk DB ¹
Tunnels			
	1	129042A	Offset Crawl Tunnel 24"Offset Deck To Deck

C. Kompan play equipment shall be as follows:

	Qty	Model Number	Description
Slides			
	1	PCM110123	Embankment Slide
Supernova, Carousels & Spinners			
	1	GXY960	Supernova

D. Berliner play equipment shall be as follows:

	Quantity	Model Number	Description
Swings			
	1	97.100.025	Cloud 9

2.02 PLAYHOUSE

- A. The playhouse shall be the Little Merry Hobbit Hole Wooden Playhouse manufactured by Wooden Wonders, PO Box 108, Unity, ME 04988, 1-855-462-2484, or approved equal.
- B. The playhouse shall include the following:
1. Straight edge cedar clapboard roofing, with a waterproof underlayment, edge flashing tape, a cedar ridge and stainless steel screws
 2. One (1) 16" diameter round window offset from the front door
 3. One (1) 20" diameter round window centered on the back wall
 4. A set of screen and plexiglass inserts for each window
 5. 1" x 10" shiplap pine siding
 6. v-match pine roof decking
 7. stain grade pine trim
 8. solid floor base sheathed in heavy duty utility grade Advantech flooring
 9. floor base framed with pressure treated 2x4s
- C. The 3' diameter round front door and heavy duty forged iron door hinges that come with this model are not required and shall not be installed.

- D. Contractor shall treat the exterior walls and trims with any exterior wood treatment within 3-4 months of receipt. Colors to be selected by the Owner's Representative.

2.03 RESILIENT SAFETY SURFACE

- A. The resilient safety surface shall meet the requirements as specified in Section 32 18 00 of the Specifications.

2.04 CAST IN PLACE CONCRETE

- A. Concrete for the footings will be cast in place cement concrete as specified in Section 03 30 00 of the Specifications. Top of concrete footings shall be twelve (12) inches minimum below finished grade.

2.05 MAINTENANCE KIT

- A. The Contractor shall provide the Town with a maintenance kit that is to include twenty (20) replacement hardware covers / caps for each play structure, any special tools required for replacement of parts, one (1) gallon of graffiti removal / cleaning solutions as recommended by the manufacturer, one (1) gallon of touch-up paint for each color of painted metal, a manual that includes all installation and maintenance instruction provided by the manufacturer.
- B. All maintenance parts are to be delivered to a location specified by the owner.

PART 3 – EXECUTION

- 3.01 The Contractor shall assemble the specified equipment under the supervision of an approved Supervisor per the manufacturer's instructions, the contract drawings and these Specifications.
- 3.02 The Contractor shall locate the structures to the lines and grades specified in the drawings in these Specifications and per the specifications of the manufacturer of the equipment. Adjust all equipment to suit site gradients; no sloping platforms, tracks, or members intended to be horizontal shall be accepted.
- 3.03 The excavation for the footings shall be done as specified in Section 31 23 00 EXCAVATION BORROW AND BACKFILL of these Specifications and according to the Contract Drawing details.
- 3.04 The equipment shall be located and brought to the heights as shown in the drawings and as recommended by the manufacturer with vertical and horizontal members set plumb and then braced to be held in place.
- 3.05 The concrete shall be poured around the supporting pieces of the equipment to the grades

detailed. The concrete shall be poured and cured per Section 03300 of these Specifications. Slope tops of footings to drain; set bottom of vertical members into gravel base to ensure drainage; do not encase bottom in concrete.

- 3.06 After the specified cure period of the concrete has passed the bracing may be removed.
- 3.07 The fills and surfaces shall then be placed and brought to the grades shown in the Contract Drawings and in accordance with Section 31 23 00 EXCAVATION BORROW AND BACKFILL of these Specifications.

PART 4 - GUARANTEE AND ACCEPTANCE/LIABILITY

- 4.01 All operating parts and structural elements of the play equipment and safety surface shall be guaranteed against failure or defect during normal use and operation for the entire warranty period as established by the manufacturer.
- 4.02 Any defective elements shall be replaced in part or whole by the Contractor at no cost to the Owner.
- 4.03 The Contractor and the manufacturer shall hold the Owner and Owner's Representative harmless from any and all damages or liability resulting from negligent acts and omissions on the part of the Contractor or manufacturer, or resulting from defective parts, or improperly assembled equipment. Contractor shall provide secure storage for all equipment on job site.
- 4.04 The Contractor is responsible for securing a Certified Playground Safety Inspector to ensure ASTM and SPSC compliance. A certificate of compliance will be issued to the Owner prior to final inspection.

END OF SECTION

SECTION 12 93 00

SITE FURNISHINGS

PART 1 - GENERAL

1.01 RELATED DOCUMENTS

- A. The General Documents, as listed in the Table of Contents, and applicable parts of Division 1, General Requirements shall be included in and made a part of this Section.
- B. Examine all Drawings and all other Sections of the Specifications for requirements therein affecting the work of this trade.

1.02 SCOPE OF WORK

- A. The work of this Section consists of all site improvements and related items as indicated on the Drawings and/or as specified herein and includes, but is not limited to, the following:
 - 1. Benches
 - 2. Mounting Hardware

1.03 RELATED WORK UNDER OTHER SECTIONS

- A. The following items of related work are specified and included in other Sections of the Specifications:
 - 1. SECTION 31 23 00 – EXCAVATION BORROW AND BACKFILL
 - 2. SECTION 03 30 00 – CAST IN PLACE CONCRETE

1.04 EXAMINATION OF CONDITIONS

- A. The Contractor shall fully inform themselves of existing conditions of the site before submitting his bid and shall be fully responsible for carrying out all site work required to fully and properly execute the work of the Contract, regardless of the conditions encountered in the actual work. No claim for extra compensation or extension of time will be allowed on account of actual conditions inconsistent with those assumed.
- B. Plans, surveys, measurements and dimensions under which the work is to be performed are believed to be correct to the best of the Owner's Representative's knowledge, but the Contractor shall have examined them for himself during the bidding period, as no allowance will be made for any errors or inaccuracies that may be found therein.

1.05 SCHEDULING

- A. The Contractor shall submit to the Owner's Representative, for approval by the Owner, a progress schedule for all work as specified herein.

1.06 QUALITY ASSURANCE

- A. Materials and methods of construction shall comply with the following standards:
 - 1. ASTM: American Society for Testing and Materials
 - 2. ANSI: American National Standards Institute
 - 3. FS: Federal Specifications
 - 4. IMI: International Masonry Institute
 - 5. PCA: Portland Cement Association
- B. Qualifications of Workers: Use adequate numbers of skilled workers who are trained in the necessary crafts and who are completely familiar with the specified requirements and methods needed for the proper performance of the work of this Section.
- C. Layout: After staking out the work, and before beginning final construction, obtain the Owner's Representative's approval for layout. Contractor shall make adjustments as determined by the Owner's Representative. Owner's Representative may make adjustments to layout as is required to meet existing and proposed conditions without additional cost to the contract price.

1.07 SUBMITTALS

- A. Shop Drawings: Submit shop drawings for all specified items in accordance with Division 1 requirements.
- B. Product Information: Provide manufacturer's data showing installation and limitations in use. Supply Certificates of Compliance for all materials required for fabrication and installation, certifying that each material item complies with, or exceeds, specific requirements.

PART 2 – PRODUCTS

2.01 Benches – All Types

- A. Benches shall be the Carnival Curved Bench manufactured by Thomas Steele Division, Graber Manufacturing, Inc. 1080 Uniek Drive Waunakee, WI 53597, P(800) 448-7931, P(608) 849-1080, F(608) 849-1081, WWW.MADRAX.COM, E-MAIL: SALES@MADRAX.COM, or approved equal. Finish shall be powder coated. Color to be selected by the Owner's Representative. All benches shall be surface mounted. Armrests shall be included, five (5) Minimum. All hardware shall be galvanized steel conforming to AISI Type 304 and ASTM A193 latest requirements.

2.02 Mounting Hardware

All bolts, screws, nuts, washers, and other mounting hardware required for the installation of surface mounted site furnishings shall be stainless steel. All surface mounted site furnishes shall be installed in accordance with manufacturer's recommendations.

PART 3 - EXECUTION

3.01 INSTALLATION

- A. The installer shall examine previous work, related work, and conditions under which this work is to be performed and notify the Contractor in writing of all deficiencies and conditions detrimental to the proper completion of this work. Beginning work means installer accepts substrates, subgrades, previous work, and conditions.
- B. All site furnishings shall be assembled in accordance with the manufacturer's instructions. Components that are chipped, dented, scratched or otherwise damaged shall not be accepted and must repaired or replaced in a manner acceptable to the Owner's Representative.
- C. All mounting bolts for site furnishings shall be cut down to extend no further than 1/8" above any nuts, washers or other fasteners.

END OF SECTION

SECTION 31 00 00

EARTHWORK

PART 1 - GENERAL

1.01 WORK INCLUDED:

The Contractor shall make excavations of normal depth in earth for trenches and structures, shall backfill and compact such excavations to the extent necessary, shall furnish the necessary material and construct embankments and fills, and shall make miscellaneous earth excavations and do miscellaneous grading.

1.02 RELATED WORK:

- A. Section 01 11 00, CONTROL OF WORK AND MATERIALS
- B. Section 01 57 19, ENVIRONMENTAL PROTECTION
- C. Section 31 05 19.13, GEOTEXTILE FABRICS
- D. Section 31 11 00, CLEARING AND GRUBBING
- E. Section 31 23 19, DEWATERING
- F. Section 31 50 00, SUPPORT OF EXCAVATION

1.03 REFERENCES:

American Society for Testing and Materials (ASTM)

ASTM	C131	Test Method for Resistance to Degradation of Small Size Coarse Aggregate by Abrasion and Impact in the Los Angeles Machine.
ASTM	C136	Method for Sieve Analysis of Fine and Coarse Aggregates.
ASTM	C330	Specification for Lightweight Aggregate for Structural Concrete.
ASTM	D1556	Test Method for Density of Soil in Place by the Sand Cone Method.
ASTM	D1557	Test Methods for Moisture-density Relations of Soils and Soil Aggregate Mixtures Using Ten-pound (10 Lb.) Hammer and Eighteen-inch (18") Drop.
ASTM	D2922	Test Methods for Density of Soil and Soil-aggregate in Place by Nuclear Methods (Shallow Depth).

Massachusetts Department of Transportation (MassDOT) Standard Specifications for Highways and Bridges.

Code of Massachusetts Regulations (CMR) 310.40.0032 Contaminated Media and Contaminated Debris

Code of Massachusetts Regulations (CMR) 520 CMR 14.00 Excavation & Trench Safety Regulation

1.04 SUBMITTALS: IN ACCORDANCE WITH REQUIREMENTS OF GENERAL SPECIFICATIONS, SUBMIT THE FOLLOWING:

Samples of all materials proposed for the project shall be submitted to the Engineer for review. Size of the samples shall be as approved by the Engineer.

1.05 PROTECTION OF EXISTING PROPERTY:

- A. The work shall be executed in such manner as to prevent any damage to facilities at the site and adjacent property and existing improvements, such as but not limited to streets, curbs, paving, service utility lines, structures, monuments, bench marks, observation wells, and other public or private property. Protect existing improvements from damage caused by settlement, lateral movements, undermining, washout and other hazards created by earthwork operations.
- B. In case of any damage or injury caused in the performance of the work, the Contractor shall, at its own expense, make good such damage or injury to the satisfaction of, and without cost to, the Owner. Existing roads, sidewalks, and curbs damaged during the project work shall be repaired or replaced to at least the condition that existed at the start of operations. The Contractor shall replace, at his own cost, existing benchmarks, observation wells, monuments, and other reference points, which are disturbed or destroyed.
- C. Buried drainage structures and pipes, observation wells and piezometers, including those which project less than eighteen inches (18") above grade, which are subject to damage from construction equipment shall be clearly marked to indicate the hazard. Markers shall indicate limits of danger areas, by means which will be clearly visible to operators of trucks and other construction equipment, and shall be maintained at all times until completion of project.

1.06 DRAINAGE:

- A. The Contractor shall provide, at its own expense, adequate drainage facilities to complete all work items in an acceptable manner. Drainage shall be done in a manner so that runoff will not adversely affect construction procedures or cause excessive disturbance of underlying natural ground or abutting properties.

1.07 FROST PROTECTION AND SNOW REMOVAL:

- A. The Contractor shall, at its own expense, keep earthwork operations clear and free of accumulations of snow as required to carry out the work.
- B. The Contractor shall protect the subgrade beneath new structures and pipes from frost penetration when freezing temperatures are expected.

PART 2 - PRODUCTS

2.01 MATERIALS:

A. GRAVEL BORROW:

Gravel Borrow shall satisfy the requirements listed in MassDOT Specification Section M1.03.0, Type b.

B. CRUSHED STONE:

Crushed stone shall satisfy the requirements listed in MassDOT Specification Section M2.01.

C. SAND BORROW:

Sand Borrow shall satisfy the requirements listed in MassDOT Specification Section M1.04.0.

D. PEASTONE:

Peastone shall be smooth, hard, naturally occurring, rounded stone meeting the following gradation requirements:

Passing 5/8 inch square sieve opening	-	100%
Passing No. 8 sieve opening	-	0%

E. BACKFILL MATERIALS:

1. Class B Backfill:

Class B backfill shall be granular, well graded friable soil; free of rubbish, ice, snow, tree stumps, roots, clay and organic matter; with 30 percent or less passing the No. 200 sieve; no stone greater than two-third (2/3) loose lift thickness, or six inches, whichever is smaller.

2. Select Backfill:

Select backfill shall be granular, well graded friable soil, free of rubbish, ice, snow, tree stumps, roots, clay and organic matter, and other deleterious or organic material; graded within the following limits:

<u>Sieve Size</u>	<u>Percent Finer by Weight</u>
3"	100
No. 10	30-95
No. 40	10-70
No. 200	0-10

F. PROCESSED GRAVEL:

1. Processed gravel shall consist of inert material that is hard, durable stone and coarse sand, free from loam and clay, surface coatings and deleterious materials. The coarse aggregate shall have a percentage of wear, by the Los Angeles Abrasion Test, of not more than 50.
2. The gradation shall meet the following requirements:

<u>Sieve Designation</u>	<u>Percentage Passing</u>
3 in.	100
1 1/2 in.	70-100
3/4 in.	50-85
No. 4	30-60
No. 200	0-10

3. The approved source of bank-run gravel material shall be processed by mechanical means. The equipment for producing crushed gravel shall be of adequate size with sufficient adjustments to produce the desired materials. The processed material shall be stockpiled in such a manner to minimize segregation of particle sizes. All processed gravel shall come from approved stockpiles.

PART 3 - EXECUTION

3.01 DISTURBANCE OF EXCAVATED AND FILLED AREAS DURING CONSTRUCTION:

- A. Contractor shall take the necessary steps to avoid disturbance of subgrade during excavation and filling operations, including restricting the use of certain types of construction equipment and their movement over sensitive or unstable materials, dewatering and other acceptable control measures.
- B. All excavated or filled areas disturbed during construction, all loose or saturated soil, and other areas that will not meet compaction requirements as specified herein shall be removed and replaced with a minimum 12-inch layer of compacted crushed stone wrapped all around in non-woven filter fabric. Costs of removal and replacement shall be borne by the Contractor.

- C. The Contractor shall place a minimum of 12-inch layer of special bedding materials and crushed stone wrapped in filter fabric over the natural underlying soil to stabilize areas which may become disturbed as a result of rain, surface water runoff or groundwater seepage pressures, all at no additional cost to the Owner. The Contractor also has the option of drying materials in-place and compacting to specified densities.

3.02 EXCAVATION:

A. GENERAL:

1. The Contractor shall perform all work of any nature and description required to accomplish the work as shown on the Drawings and as specified.
2. Excavations, unless otherwise required by the Engineer, shall be carried only to the depths and limits shown on the Drawings. If unauthorized excavation is carried out below required subgrade and/or beyond minimum lateral limits shown on Drawings, it shall be backfilled with gravel borrow and compacted at the Contractor's expense as specified below, except as otherwise indicated. Excavations shall be kept in dry and good conditions at all times, and all voids shall be filled to the satisfaction of the Engineer.
3. In all excavation areas, the Contractor shall strip the surficial topsoil layer and underlying subsoil layer separate from underlying soils. In paved areas, the Contractor shall first cut pavement as specified in paragraph 3.02 B.1 of this specification, strip pavement and pavement subbase separately from underlying soils. All excavated materials shall be stockpiled separately from each other within the limits of work.
4. The Contractor shall follow a construction procedure, which permits visual identification of stable natural ground. Where groundwater is encountered, the size of the open excavation shall be limited to that which can be handled by the Contractor's chosen method of dewatering and which will allow visual observation of the bottom and backfill in the dry.
5. The Contractor shall excavate unsuitable materials to stable natural ground where encountered at proposed excavation subgrade, as required by the Engineer. Unsuitable material includes topsoil, loam, peat, other organic materials, snow, ice, and trash. Unless specified elsewhere or otherwise required by the Engineer, areas where unsuitable materials have been excavated to stable ground shall be backfilled with compacted special bedding materials or crushed stone wrapped all around in non-woven filter fabric.

B. TRENCHES:

1. Prior to excavation, trenches in pavement shall have the traveled way surface cut in a straight line by a concrete saw or equivalent method, to the full depth of pavement. Excavation shall only be between these cuts. Excavation support shall

be provided as required to avoid undermining of pavement. Cutting operations shall not be done by ripping equipment.

2. The Contractor shall satisfy all dewatering requirements specified in Section 31 23 19 DEWATERING, before performing trench excavations.
3. Trenches shall be excavated to such depths as will permit the pipe to be laid at the elevations, slopes, and depths of cover indicated on the Drawings. Trench widths shall be as shown on the Drawings or as specified.
4. Where pipe is to be laid in bedding material, the trench may be excavated by machinery to, or just below, the designated subgrade provided that the material remaining in the bottom of the trench is not disturbed.
5. If pipe is to be laid in embankments or other recently filled areas, the fill material shall first be placed to a height of at least 12-inches above the top of the pipe before excavation.
6. Pipe trenches shall be made as narrow as practicable and shall not be widened by scraping or loosening materials from the sides. Every effort shall be made to keep the sides of the trenches firm and undisturbed until backfilling has been completed.
7. If, in the opinion of the Engineer, the subgrade, during trench excavation, has been disturbed as a result of rain, surface water runoff or groundwater seepage pressures, the Contractor shall remove such disturbed subgrade to a minimum of 12 inches and replace with crushed stone wrapped in filter fabric. Cost of removal and replacement shall be borne by the Contractor.
8. The Contractor shall obtain a trench permit from the municipality where the trench is located prior to making any excavations of trenches (any subsurface excavation greater than three (3) feet in depth and fifteen (15) feet or less between soil walls as measured from the bottom).
9. All trenches required to be permitted must be attended, covered, barricaded, or backfilled. Covers must be road plates at least ¾-inch thick or equivalent, barricades must be fences at least 6-feet high with no openings greater than 4-inches between vertical supports and all horizontal supports required to be located on the trench-side of the fencing.

C. EXCAVATION NEAR EXISTING STRUCTURES:

1. Attention is directed to the fact that there are pipes, manholes, drains, and other utilities in certain locations. An attempt has been made to locate all utilities on the drawings, but the completeness or accuracy of the given information is not guaranteed.
2. As the excavation approaches pipes, conduits, or other underground structures, digging by machinery shall be discontinued and excavation shall be done by means

of hand tools, as required. Such manual excavation, when incidental to normal excavation, shall be included in the work to be done under items involving normal excavation.

3. Where determination of the exact location of a pipe or other underground structure is necessary for properly performing the work, the Contractor shall excavate test pits to determine the locations.

3.03 BACKFILL PLACEMENT AND COMPACTION:

A. GENERAL:

1. Prior to backfilling, the Contractor shall compact the exposed natural subgrade to the densities as specified herein.
2. After approval of subgrade by the Engineer, the Contractor shall backfill areas to required contours and elevations with specified materials.
3. The Contractor shall place and compact materials to the specified density in continuous horizontal layers, not to exceed nine (9) inches in uncompacted lifts. The degree of compaction shall be based on maximum dry density as determined by ASTM Test D1557, Method C. The minimum degree of compaction for fill placed shall be as follows:

<u>Location</u>	<u>Percent of Maximum Density</u>
Below pipe centerline	95
Above pipe centerline	92
Below pavement (upper 3 ft.)	95
Embankments	95
Below pipe in embankments	95
Adjacent to structures	92
Below structures	95

4. The Engineer reserves the right to test backfill for conformance to the specifications and Contractor shall assist as required to obtain the information. Compaction testing will be performed by the Engineer or by an inspection laboratory designated by the Engineer, engaged and paid for by the Contractor. If test results indicate work does not conform to specification requirements, the Contractor shall remove or correct the defective Work by recompacting where appropriate or replacing as necessary and approved by the Engineer, to bring the work into compliance, at no additional cost to the Owner. All backfilled materials under structures and buildings shall be field tested for compliance with the requirements of this specification.
5. Where horizontal layers meet a rising slope, the Contractor shall key each layer by benching into the slope.

6. If the material removed from the excavation is suitable for backfill with the exception that it contains stones larger than permitted, the Contractor has the option to remove the oversized stones and use the material for backfill or to provide replacement backfill at no additional cost to the Owner.
7. The Contractor shall remove loam and topsoil, loose vegetation, stumps, large roots, etc., from areas upon which embankments will be built or areas where material will be placed for grading. The subgrade shall be shaped as indicated on the Drawings and shall be prepared by forking, furrowing, or plowing so that the first layer of the fill material placed on the subgrade will be well bonded to the subgrade.

B. TRENCHES:

1. Bedding as detailed and specified shall be furnished and installed beneath the pipeline prior to placement of the pipeline. A minimum bedding thickness shall be maintained between the pipe and undisturbed material, as shown on the Drawings.
2. As soon as practicable after pipes have been laid, backfilling shall be started.
3. Unless otherwise indicated on the Drawings, select backfill shall be placed by hand shovel in 6-inch thick lifts up to a minimum level of 12-inches above the top of pipe. This area of backfill is considered the zone around the pipe and shall be thoroughly compacted before the remainder of the trench is backfilled. Compaction of each lift in the zone around the pipe shall be done by use of power-driven tampers weighing at least 20 pounds or by vibratory compactors. Care shall be taken that material close to the bank, as well as in all other portions of the trench, is thoroughly compacted to densities required.
4. Class B backfill shall be placed from the top of the select backfill to the specified material at grade (loam, pavement subbase, etc.). Fill compaction shall meet the density requirements of this specification.
5. Water Jetting:
 - a. Water jetting may be used when the backfill material contains less than 10 percent passing the number 200 sieve, but shall be used only if approved by the Engineer.
 - b. Contractor shall submit a detailed plan describing the procedures he intends to use for water jetting to the Engineer for approval prior to any water jetting taking place.
 - c. Compaction of backfill placed by water jetting shall conform to the requirements of this specification.

6. If the materials above the trench bottom are unsuitable for backfill, the Contractor shall furnish and place backfill materials meeting the requirements for trench backfill, as shown on the drawings or specified herein.
7. Should the Engineer order crushed stone for utility supports or for other purposes, the Contractor shall furnish and install the crushed stone as directed.
8. In shoulders of streets and road, the top 12-inch layer of trench backfill shall consist of processed gravel for sub-base, satisfying the requirements listed in MassDOT standard specification M1.03.1.

C. BACKFILLING ADJACENT TO STRUCTURES:

1. The Contractor shall not place backfill against or on structures until they have attained sufficient strength to support the loads to which they will be subjected. Excavated material approved by the Engineer may be used in backfilling around structures. Backfill material shall be thoroughly compacted to meet the requirements of this specification.
2. Contractor shall use extra care when compacting adjacent to pipes and drainage structures. Backfill and compaction shall proceed along sides of drainage structures so that the difference in top of fill level on any side of the structure shall not exceed two feet (2') at any stage of construction.
3. Where backfill is to be placed on only one side of a structural wall, only hand-operated roller or plate compactors shall be used within a lateral distance of five feet (5') of the wall for walls less than fifteen feet (15') high and within ten feet (10') of the wall for walls more than fifteen feet (15') high.

3.04 DISPOSAL OF SURPLUS MATERIALS:

- A. Surplus excavated materials, which are acceptable to the Engineer, shall be used to backfill normal excavations in rock or to replace other materials unacceptable for use as backfill. Upon written approval of the Engineer, surplus excavated materials shall be neatly deposited and graded so as to make or widen fills, flatten side slopes, or fill depressions; or shall be neatly deposited for other purposes as indicated by the Owner, within its jurisdictional limits; all at no additional cost to the Owner.
- B. Surplus excavated material not needed as specified above shall be hauled away and disposed of by the Contractor at no additional cost to the Owner, at appropriate locations, and in accordance with arrangements made by him. Disposal of all rubble shall be in accordance with all applicable local, state and federal regulations.
- C. No excavated material shall be removed from the site of the work or disposed of by the Contractor unless approved by the Engineer.
- D. The Contractor shall comply with Massachusetts regulations (310 CMR 40.0032) that govern the removal and disposal of surplus excavated materials. Materials, including

contaminated soils, having concentrations of oil or hazardous materials less than an otherwise Reportable Concentration and that are not a hazardous waste, may not be disposed of at locations where concentrations of oil and/or hazardous material at the receiving site are significantly lower than the levels of those oil and /or hazardous materials present in the soil being disposed or reused.

END OF SECTION

SECTION 31 05 13.13

LOAM BORROW (TOPSOIL)

PART 1 - GENERAL

1.01 WORK INCLUDED:

- A. This Section covers all labor, materials, and equipment necessary to furnish and place Loam Borrow and all related work as indicated on the drawings and as herein specified.
- B. Existing on-site topsoil that has been stockpiled may be re-used provided it meets these specifications. The Contractor shall be solely responsible to determine if adequate quantities of on-site topsoil exist that may potentially be reused.

1.02 RELATED WORK:

- A. Section 31 00 00, EARTHWORK
- B. Section 32 93 00, TREES, SHRUBS, GROWDCOVERS, AND LANDSCAPING

1.03 QUALITY ASSURANCE:

- A. For each particular source of loam, the Contractor shall send representative samples totaling approximately 10 pounds of Loam Borrow to an approved State-certified testing laboratory.
- B. Loam shall be subject to tests for Soluble Salts (1:2 soil-water ratio), Nitrogen (including nitrate and ammonium Nitrogen), Phosphorous, Potassium, Sulfate, Calcium, Magnesium, Aluminum, and Ferric Iron concentrations.
- C. Loam shall also be tested for heavy metals concentration, which shall include Boron, Cadmium, Zinc, Chromium, Copper, Lead, Manganese, and Nickel.
- D. Mechanical gradation (textural analysis) as per USDA Soil Classification System and determine Organic matter content and the pH (1:1 soil-water ratio).
- E. All tests shall be at the Contractor's expense. Laboratory test results shall state whether the Loam Borrow is acceptable as a planting medium, whether it needs to be amended, or if it fails to meet accepted requirements. Test results shall also include soil amendment and fertilizing recommendations and shall be forwarded to the Engineer at least 1month before any loaming is to be undertaken.
- F. Samples and tests shall continue to be made at the Contractor's expense until Loam Borrow to be provided is found to be acceptable to the Engineer.

1.04 SUBMITTALS:

In accordance with requirements of Section 01 33 23 SUBMITTALS, the Contractor shall submit the following:

- A. Information detailing the soil amendments including limestone, fertilizers, organic material amendments, and the name and address of the supplier and origin of Loam Borrow shall be submitted to the Engineer for approval.
- B. Soils test results shall be submitted to the Engineer for review.

PART 2 - PRODUCTS

2.01 MATERIALS:

A. LOAM BORROW:

- 1. Loam Borrow shall consist of, fertile, friable natural topsoil, typical of productive soils in the vicinity, obtained from naturally well-drained areas that have never been stripped. Loam Borrow shall be reasonably free of stumps, roots, heavy or stiff clay, stones larger than 1-inch in diameter, lumps, coarse sand, noxious weeds, sticks, brush or other litter.
- 2. Loam Borrow shall be classified as a sandy loam by the USDA textural classification system as determined by sieve and pipette or hydrometer analysis. Loam Borrow shall have the following mechanical analysis:

<u>Textural Class</u>	<u>Percent of Total Weight</u>	<u>Avg. Percentage</u>
Sand (0.05 – 2.0mm range)	45 – 75	60
Silt (0.002 – 0.05mm range)	15 – 35	25
Clay (less than 0.002mm)	5 – 20	15

- 3. Loam Borrow shall contain not less than 4 percent or more than 7 percent organic matter as determined by the loss of weight by ignition of oven-dried samples. Test samples shall be oven-dried to a constant weight at a temperature of 230 degrees F.
- 4. Loam Borrow shall not be excessively acid or alkaline, and shall not contain any phytotoxic materials or unacceptable concentration levels of any substance harmful to plant growth as determined by the soils testing laboratory. Loam Borrow shall have a pH value range between 5.0 and 6.5. Maximum soluble salt index shall be 100. The electrical conductivity (EC2) of a 1:2 soil-water suspension shall be less than or equal to 1.0 millimhos/cm. Aluminum concentration levels shall be less than 200ppm.
- 5. Loam Borrow shall not be worked, excavated, or delivered in a frozen or muddy condition. Soil structure shall not be destroyed through excessive and unnecessary handling or compaction.

6. Existing on-site topsoil may be re-used as Loam Borrow provided it meets these specifications.
7. All amendments to Loam Borrow shall be approved by the Engineer and shall be made in accordance with recommendations from the soils testing laboratory for use of Loam Borrow as a plant-growing medium and these specifications.

B. LIMESTONE:

Lime shall be an approved agricultural limestone containing at least 50 percent total oxides (calcium oxide and magnesium oxide). The material will be ground such that 50 percent of the material will pass through a No. 100 mesh sieve and 98 percent will pass a No. 2 mesh sieve. Lime shall be uniform in composition, dry and free-flowing and shall be delivered to the site in the original sealed containers, each bearing the manufacturer's guaranteed analysis.

C. FERTILIZER:

1. Fertilizer shall be a complete, standard commercial fertilizer, homogeneous and uniform in composition, dry and free-flowing, and shall be delivered to the site in the manufacturer's original sealed containers, each bearing the manufacturer's guaranteed analysis and marketed in compliance with State and Federal Laws. All fertilizer shall be used in accordance with the manufacturer's recommendations.
2. For Fertilizers containing Nitrogen, at least 50 percent of the nitrogenous elements shall be Urea-form or derived from organic sources and contain no less than 3 percent water-soluble Nitrogen.
3. Superphosphate shall be composed of finely ground phosphate rock as commonly used for agricultural purposes, containing not less than 18 percent available phosphoric acid.

D. ORGANIC MATERIAL AMENDMENTS:

1. Organic compost shall be a standard commercial product comprised of fully decomposed, 100 percent plant-derived, natural organic matter. Its composition shall furnish ample water holding capacity and cation exchange capacity for the retention of plant nutrients. Compost shall be free of sticks, stones, weed seeds, roots, mineral or other foreign matter and delivered air dry. It shall be free from excessive soluble salts, heavy metals, phytotoxic compounds, and/or substances harmful to plant growth and viability. Organic compost shall have an acidity range of 4.5 to 7.0 pH.
2. Sphagnum Peat Moss shall be a standard commercial product. Its composition shall furnish ample water holding capacity and cation exchange capacity for the retention of plant nutrients. Peat moss shall be free of sticks, stones, weeds or weed seeds, roots, mineral or other foreign matter. It shall be free from toxic substances and/or

compounds harmful to plant growth and viability. It shall be delivered air dry in standard bales and shall have an acidity range of 3.5 to 5.5 pH.

3. Humus shall be natural humus, reed peat, or sedge peat. Its composition shall furnish ample water holding capacity and cation exchange capacity for the retention of plant nutrients. Humus shall be free of sticks, stones, weeds, roots, mineral or other foreign matter and/or toxic substances harmful to plant growth and viability. It shall be low in wood content, free from hard lumps and excessive amounts of zinc and delivered air dry in a shredded or granular form. The acidity range for humus shall be 5.5 to 7.5 pH, and the organic matter content shall be not less than 85 percent, as determined by loss on ignition. The minimum water holding capacity shall be 200 percent by weight on an oven-dry basis.
4. Manure shall be well-rotted, leached, cow manure not less than 8 months or more than 2 years old. It shall be free of sawdust, shavings, or refuse of any kind and shall not contain more than 25 percent straw. It shall contain no substances harmful to plant growth. The Contractor shall furnish information regarding chemical disinfectants, if any, that may have been used in storage of the manure.

PART 3 - EXECUTION

- 3.01 After approval of rough grading, the sub-base shall be raked to a depth of 3 inches to remove stones, rock or other foreign materials 3-inches or larger in dimension. The Engineer shall inspect the work for approval, prior to placing of Loam Borrow.
- 3.02 Loam Borrow shall be placed and spread to the required depths over the locations approved by the Engineer.
- 3.03 Lime shall be uniformly applied in accordance with the soil testing laboratory recommendations, or as required by the Engineer, at a maximum rate of 100 pounds per 1000 square feet per application, in necessary quantities to achieve the pH range requirements for Loam Borrow.
- 3.04 Fertilizer shall be uniformly applied in accordance with the soil testing laboratory recommendations, or as required by the Engineer. At slopes exceeding 25 percent gradient, fertilizer shall be applied manually in a manner approved by the Engineer. Fertilizer shall not be applied between June 15 and August 31.
- 3.05 Loam Borrow shall be worked by tilling or power raking to a minimum depth of 3-inches, thoroughly incorporating the lime and fertilizer into the soil. The Loam Borrow shall then be raked until the surface is finely pulverized and smooth and compacted with rollers, weighing between 75 and 100 pounds per linear foot of tread, to an even surface conforming to the prescribed lines, grades and depths indicated on the plans.

END OF SECTION

SECTION 31 05 19.13

GEOTEXTILE FABRICS

PART 1 - GENERAL

1.01 WORK INCLUDED:

This Section covers furnishing of all labor, materials, and equipment necessary to install specified geotextile fabrics in locations shown on the drawings and as required by the Engineer.

1.02 SUBMITTALS: IN ACCORDANCE WITH REQUIREMENTS OF SECTION 01 33 23 SUBMITTALS, SUBMIT THE FOLLOWING:

Shop drawings or working drawings and material specifications shall be submitted to the Engineer for review for each type of geotextile fabric furnished. General installation practices and installation schedule shall be included.

PART 2 - PRODUCTS

2.01 EROSION CONTROL FABRIC "A":

- A. Erosion control fabric "A" shall be composed of continuous-filament fibers bonded together to form a sheet. The fabric shall be an average of 20 mils thick and possess the pore-size distribution of Tencate Mirafi 600X Fabric.
- B. Erosion Control fabric "A" shall be Tencate Mirafi 600X as manufactured by Tencate Geosynthetics, Pendergrass, GA; or approved equal.

2.02 EROSION CONTROL FABRIC "B":

- A. Erosion Control Fabric "B" shall be of the best quality proven design and construction and shall be entirely suitable in every respect for the intended service.
- B. Erosion Control fabric "B" shall be Tencate Miramesh as manufactured by Tencate Geosynthetics, Pendergrass, GA; Enkamat Soil Erosion Matting as manufactured by Bonar, Asheville, N.C.; Tenax Radix Erosion Control Netting as manufactured by Tenax Corp., Baltimore, MD or approved equal.

2.03 SOIL REINFORCEMENT FABRIC:

- A. The soil reinforcement fabric shall be an integrally formed structure with aperture geometry and rib thickness sufficient to permit mechanical interlock with the surrounding particle media. The soil reinforcement fabric shall have flexural rigidity and high tensile

modulus with continuity of tensile strength through all ribs and junctions of the structure. The fabric shall be composed of polypropylene stabilized with carbon black to resist ultraviolet degradation and be resistant to biological and chemical degradation due to all naturally occurring organisms or reagents normally encountered in natural soil environments.

- B. The soil reinforcement fabric shall be a Tensar SS-2 (BX1200) Geogrid, by Contech Construction Products Inc., Marlboro, MA; Tencate Mirafi 500X fabric, by Tencate Geosynthetics, Pendergrass, GA; or approved equal.

2.04 SOIL REINFORCEMENT GRID:

- A. The soil reinforcement grid shall permit free passage of moisture, be of sufficient strength to prevent deformation and impairment of function when subjected to wheel loads and interact with overlying soil to stabilize the overburden on slopes as steep as three to one.
- B. Soil reinforcement grid shall be Tencate Mirafi Miragrid, by Tencate Geosynthetics; or approved equal.

2.05 FILTER/DRAINAGE FABRIC:

- A. The filter/drainage fabric shall be composed of continuous-filament fibers bonded together to form a sheet. The fabric shall be an average of 20 mils thick and possess the characteristics of Tencate Mirafi 140N.
- B. The filter/drainage fabric shall be Tencate Mirafi 140N as manufactured by Tencate Geosynthetics, Pendergrass, GA; Foss-65 by Foss Manufacturing Co., Hampton, NH; US 120NW, as manufactured by US Fabrics, Cincinnati, OH, or approved equal.

2.06 GEOTEXTILE LINER PROTECTOR:

- A. The geotextile liner protector shall be a non-woven, needle punched polyester or extruded polypropylene, not less than 110 mils thick.
- B. The geotextile liner protector shall be Tencate Mirafi 180 N, by Tencate Geosynthetics, Pendergrass, GA; or approved equal.

PART 3 - EXECUTION

3.01 INSTALLATION:

A. GENERAL:

Installation of geotextile fabrics shall be strictly in accordance with manufacturer's instructions and specific layout plans and details reviewed by the Engineer.

B. EROSION CONTROL FABRIC "A":

Erosion control fabric “A” shall be installed on detention basin slopes and at drainage swale ends prior to placement of riprap and at other locations as shown on the drawings or as required by the Engineer. The fabric in place shall cover the entire riprap area. Each width of fabric shall be overlapped by the subsequent width a minimum of two feet. The Contractor shall follow the manufacturer's installation recommendations to ensure proper completion of the fabric installation, including top toe-in and bottom toe wrap.

C. EROSION CONTROL FABRIC “B”:

Erosion control fabric “B” shall be placed over the prepared surface in drainage swales and other locations as required by the Engineer. The fabric shall be unrolled, placed in the direction of water flow, overlapped, pinned down with wood stakes, and seeded. All installation work shall be in accordance with manufacturer's recommendations or as required by the Engineer.

D. SOIL REINFORCEMENT FABRIC:

The soil reinforcement fabric shall be installed on the prepared subgrade prior to placement of the gravel base and bituminous concrete pavement. The fabric in place shall be beneath the entire proposed paved area. Each width of fabric shall be overlapped by the subsequent width a minimum of two feet. The Contractor shall follow the manufacturer's installation recommendations.

E. SOIL REINFORCEMENT GRID:

The soil reinforcement grid shall be placed on the flexible membrane liner, securely fastened at the top of all slopes and interlocked to form a continuous grid below the supports, all in accordance with manufacturer's recommendations and specific project details. The reinforcement grid shall provide stability for the overlying soil drainage layer, while permitting free passage of moisture.

F. FILTER/DRAINAGE FABRIC:

1. The filter/drainage fabric shall be installed in the final graded trench bottom prior to placement of the crushed stone bedding and at other locations shown on the drawings or designated by the Engineer. The drainage fabric in place shall cover the entire trench bottom and trench sides as shown on the drawings. Each width of drainage fabric shall be overlapped in accordance with manufacturer's recommendations, but not less than 2 feet, to prevent intrusion of soil fines into the bedding.

G. GEOTEXTILE LINER PROTECTOR:

The geotextile liner protector shall be installed on top of the gas-venting layer and shall be covered by the flexible membrane liner. The protector shall provide a smooth surface to support the liner and protect against liner damage due to projections. The installation

shall be strictly in accordance with manufacturer's recommendations.

3.02 FINAL INSPECTION AND ACCEPTANCE:

- A. The Contractor shall, at his expense, have a manufacturer's representative inspect the work at completion of the installation. Any work found to be unsatisfactory shall be corrected at the Contractor's expense.
- B. The Engineer, at the Contractor's expense, reserves the right to have a manufacturer's representative inspect the installation process at any time during construction.

END OF SECTION

SECTION 31 11 00

CLEARING AND GRUBBING

PART 1 - GENERAL

1.01 WORK INCLUDED:

- A. The Contractor shall do all required clearing and grubbing as indicated on the drawings or herein specified in the area required for construction operations on the Owner's land or in the Owner's permanent or temporary easements and shall remove all debris resulting therefrom.
- B. Unless otherwise noted, all areas to be cleared shall also be grubbed.
- C. The Contractor shall not clear and grub outside of the area required for construction operations.

1.02 RELATED WORK:

Any trees and shrubs specifically designated by the Owner not to be cut, removed, destroyed, or trimmed shall be saved from harm and injury in accordance with Section 01 57 19, ENVIRONMENTAL PROTECTION.

PART 2 - PRODUCTS: NOT APPLICABLE

PART 3 - EXECUTION

3.01 RIGHT TO WOOD AND LOGS:

The Owner shall have the right to cut and remove logs and other wood of value in advance of the Contractor's operations. All remaining logs and other wood to be removed in the course of clearing shall become the property of the Contractor.

3.02 CLEARING:

- A. Unless otherwise indicated, the Contractor shall cut or otherwise remove all trees, saplings, brush and vines, windfalls, logs and trees lying on the ground, dead trees and stubs more than 1-foot high above the ground surface (but not their stumps), trees which have been partially uprooted by natural or other causes (including their stumps), and other vegetable matter such as shags, sawdust, bark, refuse, and similar materials.
- B. The Contractor shall not remove mature trees (4-inches or greater DBH) in the Owner's temporary easements.

- C. Except where clearing is done by uprooting with machinery or where stumps are left longer to facilitate subsequent grubbing operations, trees, stumps, and stubs to be cleared shall be cut as close to the ground as practicable but not more than 6-inches above the ground surface in the case of small trees, and 12-inches in the case of large trees. Saplings, brush and vines shall be cut close to the ground.

3.03 GRUBBING:

- A. Unless otherwise indicated, the Contractor shall completely remove all stumps and roots to a depth of 18-inches, or if the Contractor elects to grind the stumps, they shall be ground to a minimum depth of 18-inches.
- B. Any depression remaining from the removal of a stump and not filled in by backfilling shall be filled with gravel borrow and/or loam, whichever is appropriate to the proposed ground surface.

3.04 DISPOSAL:

All material collected in the course of the clearing and grubbing, which is not to remain, shall be disposed of in a satisfactory manner away from the site or as otherwise approved. Such disposal shall be carried on as promptly as possible and shall not be left until the final clean-up period.

END OF SECTION

SECTION 31 13 13

TREE PRUNING AND TREE AND STUMP REMOVALS

PART 1 - GENERAL

1.01 WORK INCLUDED:

- A. The work of this Section includes the following:
 - 1. Pruning - Class II, including the removal of all limbs necessary to execute the field, playground and fence work required under this contract.
 - 2. Removal of trees and stumps.
- B. Refer to the Contract Drawings for general location of trees along the site perimeter. In general, all trees are to remain and be pruned in conformance with this Specification. Tree removals shall be limited to the area denoted on the plans and shall include the removal of individual trees that would impede the construction of proposed facilities.

1.02 QUALIFICATIONS OF CONTRACTOR:

- A. This work shall be limited to individuals, partnerships and corporations who are actively engaged in the field of Arboriculture, and who demonstrate competence, experience and financial capability to carry out the terms of this project. The Owner may require proof of these qualifications.
- B. All work shall be conducted by qualified and trained personnel under the direct supervision of a Massachusetts Certified Arborist (MCA) in the Contractor's employ.

1.03 PERSONNEL:

- A. The Contractor shall submit each employee's name and title prior to the commencement of work. The Contractor shall advise the Owner of any changes in personnel assigned to this Contract.
- B. The crew foreman shall have a minimum of five (5) years climbing/pruning experience. At least one (1) crew person shall be an MCA and shall be certified in CPR.
- C. Each trimmer shall be experienced and highly qualified with the necessary tree worker skills to successfully complete the work of this Section, including the ability and training to perform aerial rescue. Said skill shall also include worker safety

and ability in compliance with current OSHA and ANSI Z-133.1 Standards.

1.04 SPECIAL REQUIREMENTS:

- A. Dutch Elm diseased wood shall be disposed of in accordance with provisions of General Laws, Chapter 87, Section 5, and Chapter 132, Sections 8 and 11 as amended; and in accordance with any additional local regulations. All wood shall be removed from the site and be properly disposed of in accordance with state and local regulations.
- B. No burning shall be permitted on the project site.
- C. Prior to commencing work, the Contractor shall submit a plan to the Owner for legal disposal of removed materials, in conformance with State and Federal regulations.

1.05 STANDARDS AND DEFINITIONS:

- A. All pruning work shall be performed in accordance with the following:
 - 1. The ANSI A300 'Standard Practices for Trees, Shrubs, and Other Wood Plant Materials' of the Secretariat: National Arborist Association, Post Office Box 1094, Amherst, New Hampshire 03031.
 - 2. American National Standards Institute (ANSI) Standard Z-133.1.
 - 3. The standards and practices of the International Society of Arborists.
 - 4. The standards and practices of the Massachusetts Arborist Association.
 - 5. The standards and practices of the American Association of Nurserymen.
- B. The term 'Owner' shall mean the Owner's designated representative charged with carrying out the requirements of this Project, Architect, Engineer, Planner, or Tree Warden as referenced herein, rendering approvals for the Owner.

1.06 EXAMINATION OF SITE AND DOCUMENTS:

- A. The Contractor shall be responsible for having a clear understanding of the existing site conditions and shall be responsible for fully carrying out the work of this Section, regardless of actual site conditions encountered.

1.07 ORDER OF WORK:

- A. Based on the site conference, the Contractor shall submit a schedule of work for the Owner's review and approval prior to beginning work. Unless otherwise

authorized by the Owner, failure of the Contractor to comply with the approved removal schedule shall be sufficient cause to give notice that the Contractor is in default of the contract.

1.08 PROTECTION OF THE VEGETATION TO BE PRESERVED:

- A. The Contractor shall protect all existing trees, shrubs, lawns and other site features designated to remain. The placement of protection devices, such as snow fence enclosures, shall, however, be at the Contractor's discretion.
- B. Damage no plant to remain by burning, pumping water, cutting of live roots or branches, or any other means. Neither vehicles nor equipment shall be parked within the dripline of trees to remain, or where ever damage may result to trees to be saved. Construction material shall not be stored beneath trees to be saved.
- C. The Contractor shall be liable for any damage to any trees, shrub, lawn or other site features to remain, and shall immediately report to the Owner. Damaged shrubs or lawns shall be restored or replaced to match existing to remain to the satisfaction of the Owner.
- D. The Contractor shall compensate the Owner for damages by installing replacement tree(s) of the size and species approved by the Owner and of sufficient quantity such that the sum of the Diameter at Breast Height (DBH) inches for replacement trees equals the total DBH inches of the damaged tree(s). Damaged shrubs shall be replaced with shrubs(s) of the same size, species, and quantity, unless determined otherwise by the Owner.

1.09 USE AND CARE OF THE SITE:

- A. The Contractor shall leave the work site at the end of each working period in a condition satisfactory to the Owner.
- B. Pavements shall be swept and lawns or other surfaces raked and/or otherwise cleaned of all material related to the work operation. Degree of clean-up required will be described by the Owner and will be based upon the character of the work area.
- C. All trimmings or any other form of debris (except diseased materials or trimmings from Elms) shall be collected and chipped. The Contractor shall remove all materials and shall dispose of such materials off site in a legal manner.
- D. No vehicles are to be stored on site. The Contractor shall be fully and solely responsible for any damage to equipment or vehicles left at the site of the work. All necessary permits shall be obtained by the Contractor.

PART 2 - PRODUCTS

2.01 EQUIPMENT:

- A. Equipment necessary for this Contract shall be properly maintained and in good operating condition to the Town's satisfaction. The Contractor shall promptly remove and replace any equipment which the Owner deems to be in unsatisfactory condition or otherwise unsuitable.
- B. Cutting tools shall be kept well sharpened to provide clean smooth cuts. Any tools utilized on any tree suspected to have cankers or other fungal, bacterial or viral diseases shall be sterilized or not used on any other specimen.
- C. A disc chipper shall be used which will process material up to twelve (12) inches in diameter.

PART 3 - EXECUTION

3.01 PRUNING:

- A. Under this Section, the Contractor shall furnish all labor, materials, equipment and transportation required to complete all aspects of the work in accordance with all local, state and federal regulations in force at the same time of this Contract and in accordance with tree pruning as specified herein.
- B. The work of this Section consists of all pruning work and related items as specified herein and includes, but is not limited to:
 - 1. Pruning - Class II throughout the designated areas and limb removal required to allow for the proper installation of all fields, play equipment and new fencing.

Class II pruning is defined as medium pruning and shall consist of the removal of dead, dying, diseased, interfering, objectionable and weak branches on the main trunks as well as those within the leaf area. An occasional branch one (1) inch or less in diameter may remain within the main leaf area where it is not practical to remove it.

3.02 DESCRIPTION OF PRUNING WORK:

- A. Pruning and trimming are generally described as the removal and disposal of limbs, branches and stubs which are either dead, potentially detrimental to the health of the tree or dangerous to pedestrians, visually deficient, interfering or otherwise objectionable as determined by the Owner.
- B. The limits of all trees to be pruned have been identified on the plans or referenced elsewhere in this specification section.

- C. Vehicle access shall be controlled and approved by the Owner.
- D. If the Contractor discovers tree(s) which have not been marked for pruning, but whose condition is such that removal is warranted, whether due to death, disease, decay, or structural weakness, such tree(s) shall not be pruned and the Contractor shall immediately report these findings in writing to the Owner and await the Owner's direction before proceeding with work on the particular tree(s) in question.
- E. All pruning shall be performed in a manner that maintains the natural aesthetic characteristics of the species and variety of trees. No topping or dehorning of trees or stubbing back of branches shall be permitted. All cuts shall be made to a lateral branch that is a minimum of one third (1/3) the size of the branch being removed, unless otherwise instructed by the Owner.
- F. The use of climbing spurs or spiked shoes shall not be permitted and their use will result in the immediate cancellation of the contract.
- G. All cuts shall be made sufficiently close to the parent stem so that wound closure can be readily started under normal conditions. Cuts shall, however, never be made through the branch collar. Slab cuts and rip cuts will result in cancellation of the contract.
- H. All limbs over two (2) inches in diameter to be removed shall be precut to prevent splitting. Any branches that by falling would injure existing trees to remain or other objects shall be lowered to the ground by proper ropes.
- I. On trees known to be diseased and where there is known to be danger of transmitting the disease on tools, tools shall be disinfected with alcohol or bleach after each cut between trees.
- J. Lateral branches as well as occasional branch suckers ("water sprouts") may be retained. Complete removal of secondary laterals and branch suckers resulting in the stripping of major limbs, ("lion tailing") will not be permitted.
- K. Tree paint to seal pruning cuts shall not be used.
- L. All branches and limbs shall be manually lowered to the ground via rope and pulley. This practice must be consistent with the National Arborist Association Standards for Pruning. All grade-level artifacts and landscaping must be protected from damage.

3.03 REMOVALS:

- A. The Contractor shall furnish all labor, materials, equipment and transportation required to complete all aspects of the removals work in accordance with all local,

state, and federal regulations in force at the time of this contract and in accordance with tree and stump removals as specified herein.

3.04 DESCRIPTION OF REMOVAL WORK:

- A. Removal is generally described as the removal of groups and individual trees and shrubs which interfere with the growth of more desirable types of trees; the clearing away of lesser growth that may obscure outstanding trees; and thinning out to provide space for healthy growth by the elimination of thinner, weaker trees.
- B. The Contractor shall adhere to the specifications and provide suitable facilities for inspecting the work. Failure of the Owner to immediately reject unsatisfactory work or to notify the Contractor of deviations from the specification shall not relieve the Contractor of responsibility to correct or remedy unsatisfactory work.
- C. The Contractor shall only work on trees designated by the Owner. No compensation will be made for work performed on any other tree or trees.
- D. Trees designated to be removed shall be taken down and all leaves, branches and trunks of trees properly disposed of by chipping and removal from the premises.
- E. Fell trees in a manner that allows all site features and those trees to be saved undamaged.
- F. Removal of all the parts of each tree shall be completed on the same day that the tree is cut.
- G. Stumps shall be ground to eighteen (18) inches below grade by grinding or other means acceptable to the Owner. The void from the stump removal operations shall be filled with ordinary borrow soil to within six (6) inches of finished grade. The top six (6) inches shall be filled with screened loam, moderately tamped to prevent future settling. In grass areas the disturbed area shall be sown with grass seed of a mix appropriate to the location, as required by the Owner.
- H. Excavation or grading within the branch spread of trees to be saved shall be performed as required by the Owner. Removal of pavement such as bituminous concrete in these zones shall be by hand tools and/or air spade to ensure root health for trees to remain.
- I. All equipment to be used and all work to be performed must be in full compliance with all standards as promulgated by OSHA at the time of bidding, including but not limited to those regulations concerning noise levels, protective devices and operator safety.
- J. The Contractor shall be solely responsible for pedestrian and vehicular safety and control within the work site and shall protect the public and its property from injury

or damage that could be caused by the progress of the work. To this end the Contractor shall provide, erect, and maintain protective devices acceptable to the Owner, including but not limited to barricades, lights and warning signs.

- K. Any practice employed by the Contractor that is obviously hazardous as determined by the Owner shall be immediately discontinued by the Contractor upon receipt of either written or oral notice from the Owner to discontinue such practice.

END OF SECTION

SECTION 31 23 00

EXCAVATION, BORROW AND BACKFILL

PART 1 - GENERAL

1.01 WORK INCLUDED:

- A. Under this Section, the Contractor shall furnish all labor, materials, equipment and transportation required to complete Excavation, Borrow and Backfill work indicated on the drawings, as designated by the Engineer, or as specified herein, to complete all proposed work.
- B. Without limiting the generality thereof, Excavation, Borrow and Backfill shall include excavating, furnishing borrow materials as necessary and back-filling for the construction of all proposed work from existing grades to finished grades. Work shall include the removal of unclassified material, such as bituminous pavements, curbs, ledge and boulders under one (1) cubic yard in size, concrete, reinforced and plain, structures, fencing of various types, and metal or wood posts; and unsuitable materials of every nature throughout the site within twelve (12) inches below finished subgrade elevations for proposed work; transportation of the excavated materials; back-filling to proposed base course subgrades with approved excavated and/or furnished materials; and the disposal of unsuitable, and/or surplus excavated materials.
- C. Work under this Section shall also include the discing and harrowing of existing topsoil areas to break down all vegetation and the complete excavation, stockpiling, rehandling, spreading, and re-use (placing) of on-site topsoil in conformity with the lines, grades and dimensions shown on the plans. This material may be utilized where general embankment (not beneath pavements or structural improvements) is proposed. The Contractor shall take extreme care in the process of discing and harrowing of the existing topsoil to insure that subsoil to remain in place is not mixed with the topsoil. Disc compacted areas subject to construction traffic to the full depth of topsoil without mixing in subsoil.
- D. Work under this Section shall also include the excavation of existing base courses under existing pavement areas for re-use in proposed fill areas up to base course subgrades or loam borrow subgrades if the existing material is deemed suitable and is excavated without contamination by or mixing with unsuitable materials and subsoils. This material may be utilized for backfill over pipe cover in trenches only if all material over four (4) inches in size is removed prior to back filling. All existing materials shall be removed to the full depth of proposed work.
- E. Work under this Section shall also include the excavation of subsoil to the limit lines of proposed work. If deemed suitable by the Engineer, as meeting the criteria

or intent of paragraph 2.02 of this Specification, this material may be used as fill material for grading and general filling of any unpaved areas to bottom of proposed work. **No subsoil** shall be used for fill at proposed pavement areas or below proposed pipes or structures without meeting the requirements for paragraph 2.02A below.

- F. Work under this Section shall include the furnishing of all borrow materials required to complete the proposed work as designed. Where "processed gravel", "gravel borrow", or "gravel" is indicated in the specifications or on the drawings, only gravel conforming to this section of the specifications may be utilized.
- G. All topsoil, seed or plant material beds, whether re-used or furnished from off-site, shall conform to the loam borrow section of these Specifications.

1.02 RELATED WORK:

- A. Section 01 33 23, SUBMITTALS
- B. Section 31 05 13.13, LOAM BORROW

1.03 REFERENCE STANDARDS AND SPECIFICATIONS:

- A. References to specific standards, specifications and tests of the following technical societies, organizations, and governmental bodies may be made in the contract documents.
 - 1. AASHTO - American Association of State Highway and Transportation Officials (tests or specifications).
 - 2. ASTM - American Society for Testing and Materials.
 - 3. MassDOT Standard Specs. - Latest edition of the Standard Specifications for Highways and Bridges, Massachusetts Department of Transportation, hereinafter referred to as the "Massachusetts Standard Specifications."
 - 4. AWWA - American Waterworks Association.

1.04 SAMPLING AND TESTING:

- A. Four samples each of materials requested to be tested by the Engineer shall be taken at the locations ordered by, and in the presence of, the Engineer at the site or at the source of supply and under his direction for testing in accordance with requirements stated herein. The Contractor shall pay for these tests regardless of their results.
- B. Test results shall be submitted directly to the Engineer by a Certified Testing

Laboratory to be approved by the Engineer. No material shall be re-used or furnished until the Engineer's approval is given.

- C. All tests of any kind ordered by the Engineer shall be paid for by the Contractor regardless of test results.

1.05 SPECIAL REQUIREMENTS:

- A. If test results indicate that existing base course materials are suitable backfill material per paragraph 2.02, they shall be utilized as fill up to subgrade and for trench backfill over pipe cover. If results indicate that they meet the specifications for gravel, they may be utilized where gravel is proposed.
- B. The sequence of all excavation operations shall be such as to insure the most efficient re-use of suitable excavated materials and the use of a minimum amount of specified borrow.
- C. The Contractor shall inform and satisfy himself as to the character, quantity, and distribution of all material to be excavated. No payment will be made for the placement of any excavated material that is used for purposes other than those designated and as specified herein. Further, these shall be removed at no cost to the Owner if so required by the Engineer.
- D. The Engineer shall have final determination over the excavation, moving, placing and disposition of all materials, and shall determine the suitability of materials to be placed in excavated areas.
- E. All backfill to subgrade, shall be compacted to not less than ninety-five percent (95%) of the maximum dry density of the material as determined by the Standard AASHTO Test Designation T-180-86, Modified Proctor Test.
- F. Unsuitable and/or excess excavated materials shall be removed and properly disposed of in legal disposal areas off of the site at no additional cost to the Owner.
- G. Exploratory excavation to locate existing utilities or obstructions shall be at the Contractor's discretion to assist him in the work of this project and no extra payment shall be made for such verification. Although extra payment is not considered, lack of such payment does not constitute a waiver of the Contractor's responsibility to verify all utilities. The contractor must ensure verification of existing services and ensure the safety of the Contractor's work forces.
- H. No on-site excavated backfill materials may be used as base courses for any pavements or structural elements unless test results show these materials to meet this specification for the type of material to be utilized and are so approved by the Engineer.

1.06 SUBMITTALS/COORDINATION:

- A. The Contractor, per Section 01 33 23 SUBMITTALS and Paragraph 1.04 of this Section shall furnish all necessary submittals and certifications as to Certified Testing Laboratory, disposal sites, etc.
- B. The Contractor shall notify Digsafe at 1-888-344-7233 at least seventy-two (72) hours prior to initiating excavation.
- C. Trench permit must be submitted prior to the beginning of any related excavation.

PART 2 - PRODUCTS

2.01 BORROW MATERIALS:

- A. Excavated topsoil and furnished topsoil to be utilized for landscaping must conform to Section 31 05 13.13 Loam Borrow in order to be used as Loam Borrow. Existing topsoil not passing tests for Loam Borrow may be considered suitable as general fill below subgrade, in landscaped areas only and may be utilized throughout the proposed sod and seeded areas, up to subgrades of proposed work.
- B. Gravel Borrow shall be as specified under paragraph 2.04 and shall be utilized whenever gravel is noted, including beneath pavements and structural elements unless otherwise noted. Gravel Borrow shall satisfy the requirements listed in MHD Specification Section M1.03.0, Type b. 3-inches largest dimension.
- C. Although suitable excavated backfill materials and topsoil may be reused to fill to subgrade as specified herein, if there are insufficient quantities of materials available the Contractor shall furnish Suitable Backfill as specified in paragraph 2.02a below.
- D. If approved by the Engineer, Suitable Backfill materials excavated from beneath pavements may be utilized as backfill from twelve (12) inches above the top of pipes so long as all material over four (4) inches in size is removed from the material prior to backfilling and all trench compaction requirements may be met.
- E. Where Sand Borrow is required, materials shall conform to Section M1.04.1 of the Massachusetts Standard Specifications. Utilize Sand Borrow as necessary for pipe bedding and cover.
- F. Where Crushed Stone is required, materials shall conform to Section M2.01 of the Massachusetts Standard Specifications. Utilize Crushed Stone as necessary for granite block setting beds, backfill for sub-drains, and other details as noted in contract documents.

2.02 SUITABLE BACKFILL

- A. All other materials to be placed where Specifications or Drawings call for "fill," "back-filling," or "filling" to subgrade, shall be natural soil, well-graded and free from all organic weak, compressible, and frozen materials, and shall contain no stone larger than four (4) inches in maximum dimension. It shall be of such nature and character that it can be dried and compacted and shall be free of all expansive materials (such as high plastic clays) and of materials subject to decay, decomposition, or dissolution, and shall conform to the following gradations:

<u>U.S. Sieve No.</u>	<u>Total Percent Passing by Weight</u>
4 inch	100
#4	20-75
#40	0-25
#200	0-5

- B. If, sufficient suitable fill material is not available from excavations under this Contract, to complete filling to subgrades as specified above, additional fill, as specified under paragraph 2.02A above, shall be furnished by the Contractor from other sources at no additional cost. Excavated material from the site, and furnished material for use as Suitable Backfill, shall be deemed suitable only if they meet the requirements of paragraph 2.02A above, can be properly compacted, and are satisfactory to the Engineer.
- C. Use Suitable Backfill compacted as specified for general grading as backfill except as specified herein; fill to sub-grades of proposed work where shown.

2.03 CRUSHED STONE FOR TRENCHES (IN WATER ONLY):

- A. If trench excavations contain water, the Contractor shall substitute crushed stone, one and one-half (1-1/2) inch minus, for bedding and backfill, in accordance with MHD Standard Specifications M2.01.2, at no additional cost to the Owner, to three (3) inches above the standing water level; unless otherwise required by the Engineer.

2.04 GRAVEL BORROW:

All references to "Processed Gravel," "Gravel Borrow," or "Gravel" shall conform to the following:

- A. All proposed gravel areas, utilizing salvaged or furnished materials shall conform to Section M1.03.0 Type "c", with maximum stone size two (2) inches in dimension, and Section 150 Embankment, of the Massachusetts Standard Specifications and shall consist of inert material that is hard, durable stone and coarse sand, free from loam and clay, surface coatings, and deleterious materials.

- B. Gradation requirements for gravel borrow shall be determined by AASHTO-T11 and T27 and shall conform to the following:

<u>Sieve</u>	<u>Percent Passing</u>
2"	100
1/2"	50-85
No. 4	40-75
No. 50	8-28
No. 200	0-10

- C. Excavated materials from on-site may be utilized in all areas calling for gravel if they pass the test requirements for paragraph 2.04A above except that only stones above four (4) inches must be removed to reutilize the materials.

2.05 SAND BORROW:

- A. The Sand Borrow shall consist of inert material that is hard durable coarse sand, free from loam, clay, roots, trash, frozen materials and other deleterious or organic materials. The sieve gradation requirements shall conform to the following:

Percent By Weight Passing

<u>Size of Sieve</u>	<u>Minimum</u>	<u>Maximum</u>
# 4	100	
# 16	55	80
# 50	10	25
#100	2	8
#200	0	2

PART 3 - EXECUTION

3.01 EXCAVATION AND FILLING:

- A. Excavation and filling shall be executed to such depth that sufficient material will be left above the designated grade to allow for specified compaction to the required sub-grade. Should the Contractor, through negligence or other fault, excavate below the designated lines, he shall replace such excavation with approved materials, in an approved manner and condition, at his own expense.
- B. When the plans require excavation in areas in proximity to existing sidewalks, structures and utilities, it shall be the responsibility of the Contractor, at his own expense, to provide adequate and suitable drainage away from proposed work and existing features or use other satisfactory means and methods to protect and

maintain the stability of such construction within or adjacent to the limits of work.

- C. Protect all existing trees, shrubs or other plan referenced features to remain. Hand excavate around all items to remain including tree roots or where utilities must be verified. Exposed tree roots shall be immediately covered with Loam Borrow in accordance with these specifications.
- D. No roots greater than two (2) inches in diameter shall be cut from trees to remain without approval of the Engineer. Roots greater than one-half (1/2) inch in diameter that are cut or broken shall be promptly pruned to a smooth clean cut and painted with an approved compound.
- E. Any removal of existing facilities required in order to achieve the excavation to proceed, such as fences, walls, walkways, etc., shall be accomplished by the Contractor at no additional cost to the Owner. Restoration of these facilities shall be to a condition equal to that before removal, and safe and operational to the satisfaction of the Engineer.
- F. Excavation shall be performed to the lines, grades, and elevations shown on the plans or as required by the Engineer, and shall be made in such a manner that the requirements for formation of the subgrade can be followed.
- G. No excavation shall be started until the Engineer has reviewed and acknowledged the area of proposed construction. All material encountered, of whatever nature within the limits indicated, shall be removed and disposed of as directed. During the process of excavation, the grade shall be maintained in such condition that it will be well drained at all times.
- H. The planes at the bottom of the excavation (in cut), or the top of the fill, when completed, shall be known as the subgrade, and shall be true to the lines, grades and cross section shown on the plans, to allow proposed work (base courses and finished courses) to be completed.
- I. Hardpan, loose rock, boulders or other material unsatisfactory for subgrades shall be excavated to a depth as the Engineer may require below the contemplated subgrade. Muck, peat, matted roots or other yielding material unsatisfactory for subgrade foundation shall be removed to such depth as required to provide a satisfactory foundation. Unsatisfactory materials shall be disposed of by the Contractor. The portion so excavated shall be refilled with suitable backfill as specified, furnished or obtained from the grading operations, or gravel borrow, as required, and thoroughly compacted. Such excavation and filling beyond the limits called for on the plans shall be considered extra work and shall be processed accordingly. Solid ledge (not able to be removed by machine) or boulders (over 1 c.y.) encountered within the proposed work lines shall be removed as required by the Engineer and shall be considered extra work and processed accordingly. Clean off overburden for measurement by the Engineer and do not proceed without the

written approval of the Engineer. Cross sections shall be taken and reviewed by the Engineer for quantity approval.

- J. The removal of existing structures and utilities required to permit the orderly prosecution of the work shall be accomplished by the Contractor as directed and under this Section, unless otherwise shown on the plans. All existing foundations and structures shall be excavated to at least three (3) feet below the bottom of the proposed subgrade and the material properly disposed of off site. All such excavations shall be back-filled with Suitable Backfill and compacted. Floors of structures to be abandoned shall be broken, to ensure drainage, at no additional cost.
- K. All unsuitable excavated material shall be legally disposed of outside of, and away from, the project limits. All suitable excavated material deemed surplus by the Engineer shall become the property of the Contractor and shall be properly removed from the site.
- L. The subgrade under areas to be paved shall be brought to proper line and grade by excavating and/or placement of compacted fill with suitable excavated material or gravel borrow as specified herein. Where filling is not required, the undisturbed subgrade shall be compacted according to the requirements stated herein.
- M. Fills to subgrade level shall be formed of successive layers not exceeding lifts six (6) inches in depth and each layer shall be compacted to not less than 95 percent of maximum dry density of the material as determined by the standard AASHTO Test Designation T-180-86, Modified Proctor Test. Testing shall be done a minimum of 50 feet on center through out the site where pavements are proposed.
- N. No additional payment will be made for materials removed, manipulated or replaced by the Contractor in order to obtain the specified density. Any removal, manipulation, aerating, replacement and re-compaction of materials necessary to obtain the required density shall be considered as incidental to the excavation and compaction operations and shall be performed by the Contractor at no additional cost.
- O. Topsoil excavation and rehandling shall consist of discing and harrowing existing topsoil areas at ninety (90) degrees to each prior operation to minimum 12-inch depth or as specified by Engineer, and removing topsoil from all areas of proposed work and placing and grading the topsoil in embankment areas. Topsoil encountered below subgrade shall remain in place unless new paving is to be placed thereon and only as required by the Engineer. Then, such topsoil shall be excavated and rehandled, replaced with Suitable Backfill materials or gravel borrow and compacted as herein specified or as required by the Engineer.
- P. All areas exhibiting grass or weed growth shall be tilled by disc/harrow or rototilled in two directions to completely break up sod clumps prior to stripping the topsoil, and shall be stored in stockpiles if necessary to ensure organic matter

decomposition. Such on-site stockpiled materials must be tested prior to reuse, and treated to prevent weed growth.

- Q. After the areas to receive loam borrow or skinned infield (if required) mix have been brought to subgrade, and immediately prior to placing and spreading such material, the subgrade shall be loosened by discing or rototilling to a depth of at least three inches to permit bonding of the finished material to the subgrade material. Then place and spread the loam borrow or skinned infield material to the depths required by the Drawings to establish finish grades. Refer to Screened Loam Specifications and Skinned Infield Mix Specifications (as applicable).
- R. Protect all existing areas against damage due to the work under this Contract, and perform all repair and replacement work to any such areas which are damaged hereunder.
- S. Perform all excavation and back-filling required for the installation of subdrains, utility structures, and utility lines, and appurtenances required to the lines and grades shown on the Contract Drawings and as required by the Engineer.
- T. No extra work shall be initiated without notification of the Engineer in writing, and the written approval of the Engineer in response.
- U. The Contractor shall be responsible for any and all pumping or bailing necessary to complete his operations, and to keep all areas sufficiently dry to guarantee compaction in accordance with paragraph 3.01m. above.
- V. Sawcut, with approved diamond-blade cutting device, at lines of all pavements to remain. Mark out prior to cutting for Engineer's approval.
- W. Where insufficient suitable materials of any kind exist on site for incorporation into the proposed work within proposed work lines, the Contractor shall furnish materials from off site, as necessary and in accordance with these specifications, at no additional cost to the Owner.

3.02 DRAINAGE AND DEWATERING:

- A. Upon entering the premises, the Contractor shall assume responsibility for site and surface drainage of all areas affected by its work and shall maintain such drainage during the life of this Contract in a manner acceptable to the Owner, at all times protecting and maintaining the existing conditions in adjacent areas.
- B. Legally remove by pumping, draining or bailing all water that may accumulate or be found on the site within the contract limits where excavation and grading are to be done. Excavate and form all pump wells, sumps, dams, flumes or other necessary work to keep excavations entirely clear of water. Newly made and existing concrete and masonry shall be protected from injury resulting from dewatering work by the

use of canvas, tar paper or by such other sufficient method. Maintain at all times upon the work sufficient and satisfactory pumping machinery, including standby equipment. Provide pump wells or well points and underdrains as may be required, where needed to properly handle the water. Maintain excavations free from water until date of acceptance of the project by the Owner.

- C. Water from excavations shall be disposed of in such a manner as will not cause injury to public health nor to public or private property, nor to existing work, nor to the work completed or in progress, nor cause any interference with the use of the same by the public. Under no circumstances place concrete, place fill, or install appurtenances in excavations containing free water.

3.03 SHEETING AND BRACING:

- A. The Contractor shall furnish, put in place, and maintain such sheeting and bracing, etc., as may be required to support the sides of the excavation and to prevent any movement of earth which could in any way diminish the width of the excavation below that necessary for proper construction, or otherwise injure or delay the work or endanger adjacent structures or personnel. If the Engineer is of the opinion that sufficient or proper supports have not been provided at any points, he may order additional supports put in at the expense of the Contractor.
- B. Whenever possible, sheeting shall be driven ahead of the excavation to avoid loss of material from behind the sheeting. If necessary to excavate below the sheeting, care shall be taken to avoid trimming behind the face along which the sheeting will be driven. Care shall be taken to prevent voids outside of the sheeting, but if voids are formed, they shall be immediately filled with sand borrow and compacted.
- C. The Contractor shall leave in place, to be embedded in the backfill, all sheeting, bracing, etc., which the Engineer may require it to leave in place at any time during the progress of the work, for the purpose of preventing injury to structures, personnel, utilities or property at no additional cost. Timber or steel sheeting and bracing to be left in place shall be cut-off at least two (2) feet below finish grade. This shall not constitute a waiver of the Contractor's responsibility to use his own judgement as to where sheeting shall be left in place, regardless of the Engineer's requirement.
- D. All sheeting and bracing not to be left in place shall be carefully removed in such a manner as not to endanger the construction or other structures. All voids left or caused by withdrawal of sheeting shall be immediately back-filled with approved material and compacted by ramming with tools especially adapted to that purpose, by watering, or otherwise as may be directed.

3.04 TRENCH HAND EXCAVATION:

- A. When approaching the vicinity of the dripline of trees to remain, any roots from

vegetation on abutting properties, underground pipes, conduits, or other structures, or any suspected functioning underground features, digging by machinery shall be discontinued and the excavation shall be done by hand. Hand excavation shall also be undertaken when so required by the Engineer. Such hand excavation shall be considered incidental to the trench excavation and no additional compensation will be allowed.

- B. Protection of Existing Structures - All existing pipes, conduits, poles, wires, fences, curbing, property line markers, and other structures which, in the opinion of the Engineer, are not required to be changed in location, shall be carefully supported and protected from injury by the Contractor, and in case of damage, they shall be restored by the Contractor without additional compensation, to as good a condition as that in which they were found.

3.05 BACKFILLING IN OPEN TRENCH:

- A. As soon as practical after the pipe has been installed and tested, back-filling shall begin, and shall thereafter be prosecuted expeditiously.
- B. Drainage pipe shall be back-filled with Suitable Backfill or Gravel Borrow from a plane one (1) foot above the top of the pipe to the proposed subgrade.
- C. The area around the pipe shall be bedded with Sand Borrow and back-filled only with suitable backfill material conforming to paragraphs 2.01D or 2.02B of this Specification, or Gravel Borrow from the mid-diameter of the pipe to twelve (12) inches above the top of the pipe. Substitute crushed stone as specified if water is encountered.
- D. Water pipe shall be back-filled with Suitable Backfill material or Gravel Borrow from six (6) inches above the top of the pipe to the proposed subgrade. The area around the pipe shall be bedded and back-filled only with Sand Borrow per these specifications, to six (6) inches above the top of the pipe.

3.06 BASE COURSE:

- A. The gravel shall be spread and compacted in layers not exceeding six (6) inches in depth compacted measurement and all layers shall be compacted to not less than ninety-five percent (95%) of the maximum dry density of the material as determined by the Standard AASHTO Test Designation T99 compaction test Method C at optimum moisture content as determined by the Engineer. If the material retained on the #4 sieves is fifty percent (50%) or more of the total sample this test shall not apply and the material shall be compacted to the satisfaction of the Engineer. The specific density of the Gravel Sub-base shall be maintained by determining the number of passes of a roller required to produce a constant and uniform density, after conducting a series of tests either using the sand/volume method or the nuclear device.

- B. Compaction shall continue until the surface is even and true to the proposed lines and grades within a tolerance of three-eighths (3/8) inch above or below the required cross sectional elevations and to a maximum irregularity not exceeding three-eighths (3/8) inch under a ten (10) foot line extended longitudinally. Any specific area of gravel sub-base which, after being rolled, does not form a satisfactory, solid, stable foundation shall be removed and replaced and/or recompacted by the Contractor without extra compensation.
- C. All tests for compaction shall be as ordered by the Engineer and paid for by the Contractor, regardless of their result.

3.07 SAND BORROW:

- A. The Contractor shall deliver, spread and compact Sand Borrow to conform to the lines and grades shown on the plans, and shall spread and compact the Sand Borrow in no greater than six (6) inch layers.
- B. Compaction shall continue until the surface is even and true to the proposed lines and grades indicated on the plans or as required by the Engineer.
- C. Sand shall not be placed if it is excessively moist and unable to be satisfactorily spread and compacted.
- D. Compaction for Sand Borrow shall be not less than ninety-five percent (95%) of the maximum dry density as determined by the standard AASHTO-T99, Standard Proctor Test.
- E. Compaction of the sand and any adjoining embankment material shall be done simultaneously so that the respective materials will be confined substantially to the indicated lines.
- F. Sand borrow shall be graded to a true even surface to the proposed lines and grades within a tolerance of three-eighths (3/8) inches above or below the required elevation.
- G. Any tests of materials, and/or compaction, shall be as ordered by the Engineer and paid for by the Contractor regardless of their result. Percolation tests to be verified in the field by Engineer.

END OF SECTION

SECTION 31 23 19

DEWATERING

PART 1 - GENERAL

1.01 WORK INCLUDED:

This section specifies designing, furnishing, installing, maintaining, operating and removing temporary dewatering systems as required to lower and control water levels and hydrostatic pressures during construction; disposing of pumped water; constructing, maintaining, observing and, except where indicated or required to remain in place, removing of equipment and instrumentation for control of the system.

1.02 RELATED WORK:

- A. Section 01 57 19, ENVIRONMENTAL PROTECTION
- B. Section 31 00 00, EARTHWORK
- C. Section 31 50 00, SUPPORT OF EXCAVATION

1.03 SYSTEM DESCRIPTION:

- A. Dewatering includes lowering the water table and intercepting seepage which would otherwise emerge from the slopes or bottom of the excavation; increasing the stability of excavated slopes; preventing loss of material from beneath the slopes or bottom of the excavation; reducing lateral loads on sheeting and bracing; improving the excavation and hauling characteristics of sandy soil; preventing rupture or heaving of the bottom of any excavation; and disposing of pumped water.

1.04 QUALITY ASSURANCE:

- A. The Contractor is responsible for the adequacy of the dewatering systems.
- B. The dewatering systems shall be capable of effectively reducing the hydrostatic pressure and lowering the groundwater levels to a minimum of 2 feet below excavation bottom, unless otherwise required by the Engineer, so that all excavation bottoms are firm and dry.
- C. The dewatering system shall be capable of maintaining a dry and stable subgrade until the structures, pipes and appurtenances to be built therein have been completed to the extent that they will not be floated or otherwise damaged.
- D. The dewatering system and excavation support (see Section 31 50 00, SUPPORT OF EXCAVATION) shall be designed so that lowering of the groundwater level outside the excavation does not adversely affect adjacent structures, utilities or wells.

1.05 SUBMITTALS:

- A. In accordance with Section 01 33 23, Contractor shall submit a plan indicating how it intends to control the discharge from any dewatering operations on the project, whether it is discharge of groundwater from excavations or stormwater runoff during the life of the project.

PART 2 - PRODUCTS: NOT APPLICABLE

PART 3 - EXECUTION

3.01 DEWATERING OPERATIONS:

- A. All water pumped or drained from the work shall be disposed of in a manner that will not result in undue interference with other work or damage to adjacent properties, pavements and other surfaces, buildings, structures and utilities. Suitable temporary pipes, flumes or channels shall be provided for water that may flow along or across the site of the work. All disposal of pumped water shall conform to the provisions of Section 01 57 19 ENVIRONMENTAL PROTECTION.
- B. Dewatering facilities shall be located where they will not interfere with utilities and construction work to be done by others.
- C. Dewatering procedures to be used shall be as described below:
 - 1. Crushed stone shall encapsulate the suction end of the pump to aid in minimizing the amount of silt discharged.
 - 2. For dewatering operations with relatively minor flows, pump discharges shall be directed into hay bale sedimentation traps lined with filter fabric. Water is to be filtered through the hay bales and filter fabric prior to being allowed to seep out into its natural watercourse.
 - 3. For dewatering operations with larger flows, pump discharges shall be into a steel dewatering basin. Steel baffle plates shall be used to slow water velocities to increase the contact time and allow adequate settlement of sediment prior to discharge into waterways.
 - 4. Where indicated on the contract drawings or in conditions of excess silt suspended in the discharge water, silt control bags shall be utilized in catch basins.
- D. The Contractor shall be responsible for repair of any damage caused by his dewatering operations, at no cost to the Owner.

END OF SECTION

SECTION 31 50 00

SUPPORT OF EXCAVATION

PART 1 - GENERAL

1.01 WORK INCLUDED:

- A. This section of the specification covers wood sheeting and bracing for support of excavations. The requirements of this section shall also apply, as appropriate, to other methods of excavation support and underpinning which the Contractor elects to use to complete the work.
- B. The Contractor shall furnish and place timber sheeting of the kinds and dimensions required, complying with these specifications, where indicated on the drawings or required by the Engineer.

1.02 RELATED WORK:

- A. Section 31 23 19, DEWATERING.
- B. Section 31 00 00, EARTHWORK.

1.03 QUALITY ASSURANCE:

- A. This project is subject to the Safety and Health regulations of the U.S. Department of Labor set forth in 29 CFR, Part 1926, and to the Massachusetts Department of Safety and Department of Labor, Division of Occupational Safety “Excavation & Trench Safety Regulation (520 CMR 14.00)” and “Rules and Regulations for the Prevention of Accidents in Construction Operations (454 CMR 10.0 et seq.).” Contractors shall be familiar with the requirements of these regulations.
- B. The excavation support system shall be of sufficient strength and be provided with adequate bracing to support all loads to which it will be subjected. The excavation support system shall be designed to prevent any movement of earth that would diminish the width of the excavation or damage or endanger adjacent structures.

PART 2 - PRODUCTS

2.01 MATERIALS:

- A. Timber sheeting shall be sound spruce, pine, or hemlock, planed on one side and either tongue and grooved or splined. Timber sheeting shall not be less than nominal 2-inches thick.

- B. Timber and steel used for bracing shall be of such size and strength as required in the excavation support design. Timber or steel used for bracing shall be new or undamaged used material which does not contain splices, cutouts, patches, or other alterations which would impair its integrity or strength.

PART 3 - EXECUTION

3.01 INSTALLATION:

- A. Work shall not be started until all materials and equipment necessary for their construction are either on the site of the work or satisfactorily available for immediate use as required.
- B. The sheeting shall be securely and satisfactorily braced to withstand all pressures to which it may be subjected and be sufficiently tight to minimize lowering of the groundwater level outside the excavation, as required in Section 31 23 19, DEWATERING.
- C. The sheeting shall be driven by approved means to the design elevation. No sheeting may be left so as to create a possible hazard to safety of the public or a hindrance to traffic of any kind.
- D. If boulders or very dense soils are encountered, making it impractical to drive a section to the desired depth, the section shall, as required, be cut off.
- E. The sheeting shall be left in place where indicated on the drawings or required by the Engineer in writing. At all other locations, the sheeting may be left in place or salvaged at the option of the Contractor. Steel or wood sheeting permanently left in place shall be cut off at a depth of not less than two feet below finish grade unless otherwise required.
- F. All cut-off will become the property of the Contractor and shall be removed by him from the site.
- G. Responsibility for the satisfactory construction and maintenance of the excavation support system, complete in place, shall rest with the Contractor. Any work done, including incidental construction, which is not acceptable for the intended purpose shall be either repaired or removed and reconstructed by the Contractor at his expense.
- H. The Contractor shall be solely responsible for repairing all damage associated with installation, performance, and removal of the excavation support system.

END OF SECTION

SECTION 32 11 00

SIDEWALK CONSTRUCTION AND REPLACEMENT

PART 1 - GENERAL

1.01 WORK INCLUDED:

The Contractor shall furnish all labor, materials, equipment and incidentals required to restore sidewalks and/or construct new or replacement cement concrete sidewalks where directed or where existing sidewalks are disturbed by the Contractor, as shown on the drawings and described herein. The Contractor shall also furnish all materials where shown on the drawings or as required by the Engineer.

1.02 RELATED WORK:

- A. Section 31 00 00, EARTHWORK

1.03 REFERENCES:

The following standards form a part of these specifications, as referenced:

Massachusetts Department of Transportation (MassDOT)
Standard Specifications for Highways and Bridges

1.04 SUBMITTALS:

- A. In accordance with Section 01 33 23 SUBMITTALS the Contractor shall submit shop drawings and/or materials specifications for each component of the work to be performed under this section of the Specifications.

1.05 SYSTEM DESCRIPTION:

- B. HOT MIX ASPHALT AND CEMENT CONCRETE SIDEWALKS AND CEMENT CONCRETE WHEELCHAIR RAMPS:
 - 1. Except as otherwise indicated, cement concrete sidewalks shall be constructed in accordance with the requirements of Section 701, Sidewalks, Wheelchair Ramps and Driveways, of the latest edition of the MassDOT Standard Specifications for Highways and Bridges, and all amendments thereto.
- C. Water boxes, manhole frames, and all other castings shall be carefully set to the proposed finished grade.
- D. Sidewalks shall not be less than 48-inches in width, excluding curbing. An unobstructed path of travel shall be provided which is at least 36-inches clear, excluding curbing.

PART 2 - PRODUCTS

2.02 CEMENT CONCRETE SIDEWALKS:

- A. Cement concrete sidewalks shall be constructed with air entrained Cement Concrete with a minimum compressive strength of 4000 psi at 28 days.
- B. Cement concrete shall conform to the requirements of MassDOT M4.02.

PART 3 - EXECUTION:

3.02 CEMENT CONCRETE SIDEWALKS AND WHEELCHAIR RAMPS:

- A. Concrete for sidewalks shall be a minimum of 4-inches thick. At driveways, the sidewalks shall be 6 inches thick.
- B. The subgrade for the walk or driveway shall be shaped to a true surface conforming to the proposed slope of the walk, thoroughly rolled at optimum moisture content and tamped with a power roller weighing not less than one ton and not more than 5 tons. All depressions occurring shall be filled with suitable material and again rolled or tamped until the surface is smooth and hard.
- C. After the subgrade has been prepared as hereinbefore specified, a subbase of gravel borrow at optimum moisture content shall be placed, thoroughly rolled by a power roller, and tamped. The gravel borrow shall be a minimum of 8-inches in thickness.
- D. The forms for sidewalks shall be smooth, free from warp, strong enough to resist springing out of shape, and deep enough to conform to the thickness of the proposed walk. All mortar or dirt shall be completely removed from forms that have been previously used. The forms shall be well staked, thoroughly braced, and set to the established lines with their upper edge conforming to the grade of the finished walk. The finished walk shall have sufficient pitch from the outside to the edge of the walk to provide for surface drainage. This pitch shall be 1.5% unless otherwise directed by the Engineer. Before the concrete is placed, the subbase for sidewalks shall be thoroughly dampened until it is moist throughout but without puddles of water.
- E. Concrete shall be conveyed from the place of mixing to the place of deposit in such a manner that no mortar will be lost, and the composition of the mix shall be uniform, showing neither excess nor lack of mortar in any one place. The consistency shall be such that water will float to the surface under heavy tamping. The concrete shall be placed as close to its final position as practicable and thoroughly consolidated, with precautions taken not to overwork it while it is still plastic. The concrete shall be thoroughly spaded along the forms or screeds to eliminate voids and honeycombs at the edges. Retempering of concrete will not be permitted.

- F. Concrete shall be placed in alternate slabs not exceeding 30 feet in length. Slabs shall be separated by transverse preformed expansion joint filler ½-inch thick. The surface of all concrete sidewalks shall be uniformly scored into block units of not more than 40 square feet. The depth of the scoring shall be at least one quarter of the thickness of the sidewalk.
- G. When concrete sidewalks are constructed adjacent to curbing, building foundations, retaining walls, light pole bases or fixed structures, ½-inch thick premolded joint filler shall be used between the newly constructed sidewalk and the structure.
- H. Finishing of the concrete surface shall be done by experienced and competent cement finishers as soon as is practicable. Finishing shall be delayed until all bleed water and water sheen has left the surface and the concrete has begun to stiffen. The concrete surface shall be finished as directed with a steel trowel or wood float to give a smooth, uniform and attractive surface finish and uniformly scored into block units or areas of not more than 36 square feet. Following this, the Contractor shall draw a nylon push broom lightly over the surface to produce a non-slip surface. Application of neat cement to the surface to hasten hardening is prohibited.
- I. The Contractor shall protect the newly placed concrete surface against vandalism and marking or defacing and must stand ready to replace any blocks which, in the opinion of the Engineer, are excessively marked or defaced, at no additional cost to the Owner. When completed the walks shall be kept moist and protected from traffic and weather for at least 3 days.
- J. Adequate protection shall be provided where temperatures of 40°F or lower occur during placing of concrete and during the early curing period. The minimum temperature of fresh concrete after placing and for the first 3 days shall be maintained above 55°F. In addition to the above requirements, an additional 3 days of protection from freezing shall be maintained.

END OF SECTION

SECTION 32 18 00

POURED-IN-PLACE SAFETY SURFACING

PART 1 - GENERAL

1.01 SCOPE OF WORK

- A. The Contractor shall furnish all labor, materials, equipment and transportation required for the placement of poured-in-place rubber play surfacing throughout the playground. The surfacing shall be placed at all locations identified on the Contract Drawings to the indicated grades. Layout and design of color and pattern is to be installed per the contract drawings.

1.02 SUBMITTALS

- A. In accordance with the SUBMITTAL section of these specifications submit manufacturer's specification and detail sheets for all materials to be utilized under this section.
- B. Field layout of color and pattern of surfacing to be approved by Owner's Representative prior to installation.
- C. Provide poured-in-place surface color samples for final color selection approval as required by the Owner's Representative.
- D. Post installation testing will be required by the Owner at the Contractors expense. An independent testing agency shall test to ensure a HIC of 800, contractor is responsible for removal and reinstallation if the test results do not conform.
- E. Submit copies of testing procedures and results performed by an independent testing source, which demonstrates compliance with CSPS and ASTM guidelines. Supplier must certify that safety surface depth provided meets or exceeds ASTM and ADA requirements as referenced within this specification and U.S. Consumer Product Safety Commission's Technical Guidelines for:
 - 1. "Recommendations – When tested in accordance with suggested test method in ASTM F355 procedure C; A Surface should not impact a peak acceleration in excess if 200G's to an instrumented ANSI head-form dropped on a surface from the maximum fall height as delineated in the standard specification for Impact Attenuation if surface Systems Under and Around Playground Equipment Designated F1292-91."
 - 2. The surface shall meet the Head Injury Criteria (HIC) of less than 1000. Lab test shall be performed at (3) temperatures per ASTM F1292/F355E over concrete. Testing over aggregate will not be allowed.

- F. Supplier must provide copies of testing procedures and results (g-max and HIC score results) performed by independent testing source(s) which demonstrates compliance with C.P.S.C. Guidelines as referenced. Contractor shall submit test results for review and approval by the owner.
- G. Supplier must provide complete installation instructions.
- H. A certificate of insurance must be provided by the supplier which shall provide a coverage of products liability with limit of liability not less than \$1,000,000.00

1.03 QUALIFICATIONS

- A. For installation of the poured-in-place play surface the contractor shall have a minimum of five (5) years experience provide evidence of successful completion of twenty-five (25) like surfaces installed during the past five (5) years with names of clients and phone numbers.

1.03 GUARANTEE AND ACCEPTANCE/LIABILITY

- A. Safety surface shall be guaranteed against failure or defect during normal use and operation for a period of one year.
- B. Any defective elements or areas shall be replaced in part or whole by the Contractor at no cost to the owner.
- C. The Contractor and the manufacturer shall hold the Owner and Landscape Architect/Engineer harmless from any damages or liability resulting from negligent acts or omissions on the part of the Contractor or Manufacturer or improperly installed material.

PART 2 - MATERIALS

2.01 POURED-IN-PLACE-PLAY SURFACE

- A. Poured-in-place play surface shall be "Playbound" by Surface America, "Everguard" poured-in-place rubber as manufactured by Evergreen Surfacing Inc., 25 Berry Hill Road, Oyster Bay, NY 11732; (516) 864-0550, www.Everguard.com or approved equal. The City will consider "Sprinkle Flex" from VitriTurf but this request MUST be made during the bid period so that appropriate unit pricing can be established.
- B. Play surface shall meet or exceed current Consumer Product Safety Commission (CPSC) guidelines issued in 'A Handbook for Public Playground Safety' (latest edition) for the minimum potential fall height of the play equipment, current Disabilities Act Guidelines (ADA) and current American Society for Testing

Materials (ASTM) F-1292-91 requirements.

1. The Base Mat shall be a monolithic poured-in-place cushioned pad, made from a blend of recycled styrene butyrene rubber (SBR) and a polyurethane binder or approved equal. The depth of the SBR mat shall be such that in conjunction with the specified top-wearing course the total resilient surface system shall provide the required absorbency for the maximum potential fall from the specified play equipment. (Refer to Section 02886) SBR shall be mixed with the binder in a ratio of 88% SBR to 12% binder by weight to achieve maximum resilience.
2. The Top Surface shall be a monolithic poured-in-place top surface, ½” total thickness, made from a blend of ethylene propylene diene monomer (EPDM) colored rubber particles there will be up to FIVE separate colors and each shall include a custom combination of four colors with NO BLACK to be chosen by the owner’s representative during the submittal process combinations indicated in manufacturer’s brochures. Top surface shall have a tensile strength of two hundred (200) psi. The urethane binder shall be an aliphatic non-yellowing type.
3. Poured-in-place surfacing shall be placed throughout the full extent of the playlots. The total depth of poured-in-place surfacing shall sufficient to meet a HIC of not more than 1000 at installation based on maximum fall height of play structure indicate on the plans and specifications.
4. Prefabricated shock pads will not be considered equal.

2.02 RUBBERIZED TILE SURFACING

- A. This work shall consist of furnishing and installing a resilient tile surface in high use zones under swing components and at the base of slides, as recommended by the manufacturer and/or supplier, and as directed by the Engineer. Play surface shall consist of factory-molded interlocking resilient playground tile surfacing.
- B. All products shall meet current Consumer Product Safety Commission and Americans with Disabilities Act guidelines, and ASTM F-1292-91 requirements.
- C. Rubberized tile surfacing shall be SofTILE KrosLOCK as manufactured by SofSURFACES, (800-263-2363), www.sofsurfaces.com and supplied by J. P. LaRue Inc., 1-800-986-3716, or approved equal. Depth shall be as required by the manufacturer given the fall heights and color shall match the poured-in-place. Final color to be selected by Owner’s Representative. Depth shall be 3.5”.

2.03 FILTER CLOTH/FABRIC

- A. Filter fabric shall be as specified under Section 31 05 19.13 of these

Specifications.

2.04 BASE MATERIALS

- A. Crushed stone materials shall be as specified under Section 31 00 00 of these Specifications, or as otherwise indicated on the details.
- B. Concrete base material under sloped poured-in-place rubber conditions shall be as specified under Section 03 30 00 of these Specifications, or as otherwise indicated on the details.
- C. The Owner's Representative reserves the right to test backfill and base material for conformance to the specifications and Contractor shall assist as required to obtain the information. Compaction testing will be performed by the Owner's Representative or by an inspection laboratory designated by the Owner's Representative, engaged and paid for by the Contractor. If test results indicate work does not conform to specification requirements, the Contractor shall remove or correct the defective Work by recompacting where appropriate or replacing as necessary and approved by the Owner's Representative, to bring the work into compliance, at no additional cost to the Owner. All backfilled materials under structures and buildings shall be field tested for compliance with the requirements of this specification.
- D. Compaction tests are required on base material surfaces prior to rubber base course installation. Contractor shall provide testing at 3 locations at designer's direction or per Owner's direction. At the Contractor's expense, an independent testing agency must perform the work and submit the results directly to the Owner's Representative.

2.05 EDGING

- A. Refer to Contract drawings for edging locations and details and Section 05 55 00 MISCELLANEOUS METALS.
- B. Where the rubber surfacing meets bituminous concrete or landscaped areas, 1/4" x 4" steel edging with steel spikes shall be used such as that manufactured by Sure-loc Edging, 494 E. 64th Street, Holland, MI 49423 or approved equal. Color shall be black.

PART 3 - EXECUTION

3.01 PROCEDURES

- A. The Contractor shall deliver, spread and compact or place safety surfaces to conform to the lines and grades shown on the Contract Drawings. All work shall be done in accordance with the manufacturer's installation recommendations for

Poured-in-Place Play Surfaces.

- B. The Base Mat for the Poured-in-Place Play Surface shall be installed in accordance with the manufacturer's instructions. The Base Mat shall exhibit a minimum installed thickness necessary to provide the required absorbency for the maximum potential fall from the proposed play equipment. At playlot edges, place a board between the end of the poured-in-place base pour and the concrete edge and remove the board after the base has sufficiently cured. Pour the top course of poured-in-place surfacing and allow material to fill the void created by the board.
- C. The Top Surface shall be installed following installation of the cushion course, in accordance with the manufacturer's instructions. The minimum installed thickness of the top wearing course shall be ½". The contractor is responsible for insuring that no foot traffic is allowed on the surface before the curing is complete.
- C. Any tests of materials, and/or compaction shall be as ordered by the Owner's Representative, and paid for by the Contractor regardless of results.
- D. All safety surface tiles shall be installed according to manufacturer's and/or suppliers recommendation and/or specifications on a concrete base. Locations and installation methods shall be as shown as determined by the Owner's Representative.

PART 4 – GUARANTEE AND ACCEPTANCE/LIABILITY

- 4.01 All structural elements safety surface shall be guaranteed against failure or defect during normal use and operation for the entire warrantee period as established by the manufacturer.
- 4.02 Safety surfacing shall be free of defects due to workmanship or material for a minimum of ten (10) years from date of installation. Any defective elements shall be replaced in part or whole by the Contractor at no cost to the Owner.
- 4.03 The Contractor and the manufacturer shall hold the Owner and Owner's Representative harmless from any and all damages or liability resulting from negligent acts and omissions on the part of the Contractor or manufacturer, or resulting from defective parts, or improper resilient safety surface installation. Contractor shall be responsible for securing site from pedestrian traffic or vandalism while poured-in-place safety surface dries.
- 4.04 The Contractor is responsible for securing a Certified Playground Safety Inspector to ensure ASTM and CPSC compliance. A certificate of compliance will be issued to the Owner prior to final inspection.

END OF SECTION

SECTION 32 31 00

FENCES AND GATES

PART 1- GENERAL

1.01 Scope of Work

- A. The work under this Section consists of furnishing and installing Black Vinyl Chain Link (BVCL) fence and gates with posts, sleeves and appurtenances, as shown on the drawings and as specified herein including all labor, materials and equipment necessary to finish the work complete in place, but is not limited to the following:
 - 1. 4' Ht. Steel BVCL Fence and Gates
- B. Fences must meet all safety code requirements for BVCL spacing, etc.
- C. Provide product and all materials necessary for installation.
- D. Store items in original undamaged packages until ready for installation. Items must be protected from weather, careless handling and vandalism. Handle items with sufficient care to prevent any scratches or damage to the finish.

1.01 DESIGN AND PERFORMANCE REQUIREMENTS

- A. Coordinate all of the work with the Owner's Representative.
- B. Quality Standards:
 - Commonly listed standards
 - 1. ASTM – American Society for Testing and Materials.
 - 2. AAMA – American Architectural Manufacturers Association.
 - 3. AISI – American Iron and Steel Institute.
 - 4. ADA – Americans with Disabilities Act (ADA) and MAAB.
 - 5. AASHTO – American Association of State Highway and Transportation Officials.
 - 6. NLGA – National Lumber Grades Authority.
- C. Fabrication
 - 1. All wood components should be premium grade lumber.
 - 2. All hardware and fasteners shall be painted galvanized and / or stainless steel unless otherwise noted.

3. All steel components should be finished with a powder coated system that will ensure long lasting protection against acids, salts, and corrosive moisture.

D. Installation

1. Installer shall be responsible for coordinating underground utilities and structures with Dig Safe and as-builts for all proposed construction.
2. All items specified in this section shall be installed plumb and set to the existing or proposed grade.

PART 2- MATERIALS

2.01 BLACK VINYL CHAIN LINK (BVCL) FENCING

A. Color: Black, unless otherwise approved by the owner.

B. Mesh Fabric:

1. PVC or polyolefin elastomer coating, 7 mil (0.18 mm) to 15 mil (0.38mm) thickness, thermally fused over galvanized wire: ASTM F 668, Class 2b, in black color. ASTM A 641, galvanized steel core wire, tensile strength 75,000 psi (571 MPa).
2. All Heights: Helically wound and woven to height of as indicated on drawings, 1-1/4" diamond mesh of 6 gauge core wire with a diameter of 0.148" (3.76 mm) and a breakload of 1290 lbs (5740 N). Color: black, ASTM F 934.
3. Selvage of fabric knuckled at top and bottom.

C. Framing:

1. Steel pipe - Type I: ASTM F 1083, standard weight schedule 40; minimum yield strength of 25,000 psi (170 MPa); sizes as indicated. Hot-dipped galvanized with minimum average 1.8 oz/ft² (550 g/m²) of coated surface area.
2. Bottom rail must be used on all chain link fence installations
3. Post Length:
 - a) 4 Foot High Fence Post:

- 1) 4 Foot High: minimum 7.5 feet total length (3.5 feet embedded into concrete footing) unless otherwise noted per details.

4. Post and Rail Size:

- a) PVC or polyolefin elastomer coated finish: In accordance with ASTM F1043, apply supplemental color coating of 10-15 mils (0.254 - 0.38 mm) thermally fused in black color to match fabric.

- 1) 4 Foot High Fence Framing Sizes:

Corner and Line (Intermediate) Post	(2 inch) - 2.375" od
--	----------------------

Top and Bottom Rail	(1-1/4 inches) - 1.66" od
------------------------	---------------------------

Gate and End Post:	(2 1/2 inch) – 2.875" od
--------------------	--------------------------

D. Accessories: (ASTM F 626) Provide items required to complete fence system. Galvanize each ferrous metal item and finish to match framing.

1. Post caps: Formed steel, cast malleable iron, or aluminum alloy weather tight closure cap for tubular posts. For each line post provide tops to permit passage of top rail.
2. Top rail and brace ends: Pressed steel per ASTM F626, for connection of rail and brace to terminal posts.
3. Top rail sleeves: 7" (178 mm) expansion sleeve with spring, allowing for expansion and contraction of top rail.
4. Fabric Bands for Tying Fabric: Fabric shall be attached using a BAND-IT band and buckle system. Bands shall be 0.020" thickness, 200/300 series stainless steel 1/2" wide bands, with a minimum breaking strength of 850 lbs., 1/2" band capacity ear-loct design buckles to be manufactured with 0.050" thick material, 201/301 series stainless steel. Hog ring ties of 12-1/2 gauge [0.0985" (2.502 mm)] for attachment of fabric to tension wire.
5. Brace and tension (stretcher bar) bands: Pressed steel.
6. Tension (stretcher) bars: One piece lengths equal to 2" (50 mm) less than full height of fabric with a minimum cross-section of 3/16" x 3/4" (4.76 mm x 19 mm) or equivalent fiberglass rod. Provide tension (stretcher) bars where chain link fabric meets terminal posts.

7. Tension wire: Thermally fused PVC or polyolefin elastomer applied to metallic coated steel wire: Per ASTM F 1664 Class 2 b, 7 gauge, and [0.177" (4.5 mm) diameter core wire with tensile strength of 75,000 psi (517 MPa).
 8. Truss rods & tightener: Steel rods with minimum diameter of 5/16" (7.9 mm). Capable of withstanding a tension of minimum 2,000 lbs.
 9. Fasteners are to be galvanized but not vinyl coated.
- E. Setting: Refer to the 03 30 00 CAST-IN-PLACE CONCRETE for standard concrete footing requirements.

PART 3 - EXECUTION

3.01 POST INSTALLATION

- A. Install new vinyl coated chain link fence in the location(s) shown on the Contract Drawings, and as approved by the Landscape Architect.
- B. Excavation for post footings as herein before specified in Section 02300 of these Specifications, shall be in firm undisturbed or compacted soil. Post footing diameters vary according to post sizes required and are in accordance with attached details. Excavate hole depths six (6) inches lower than post bottom with bottom of posts set not less than thirty-six (36) inches below surface when in firm, undisturbed soil. Where ledge is encountered, the Contractor shall notify the Landscape Architect to determine method of installation.
- C. Place concrete around posts in a continuous pour, tamp for consolidation. Check each post for vertical and top alignment and hold in position during placement and finishing operation. Crown the top of the concrete footings to pitch water away from posts.
- D. Under bituminous pavements, tops of footings are to be finished smooth and are to pitch one (1) inch from the posts to the outside edge of the foundation.
- E. In mower strip locations, form top twelve (12) inches square and finish to match mower strip with 1/4" pitch away from posts.
 1. If applicable, top of fence footings at players' benches and cement concrete mower strips shall terminate six (6) inches below pavement finish grade.

3.02 FENCE ERECTION

- A. Top and Bottom Rails

1. Top and bottom rails shall form a continuous brace from end to end of each fence run. In addition, all end and corner posts shall be braced to the nearest line post with center brace rails. Outside sleeve type top rail coupling shall be placed a maximum of twelve (12) inches from line posts.

C. Brace Assemblies

1. Furnish and install braces and appurtenances so posts are plumb when diagonal rod is under proper tension. All "tension" assemblies shall conform to ASTM 567 and the MASS DPW Standard Specifications Section M.8.09

D. Fabric

1. The fabric shall be installed on the "public" side of the fence.
2. All fabric shall be aligned so that the top row of the fabric mesh is tied to the top rail, and so that the bottom selvage of fabric mesh stands one (1) inches above the finish grade of the lawns, pavements or concrete wall grade and that the bottom row of the fabric mesh is tied to the bottom rail.
3. Fabric shall be properly stretched and securely fastened to the posts and rails, and between posts the top and bottom of the fabric shall be fastened to the horizontal braces as herein specified, and approved by the Landscape Architect. Fabric shall be stretched uniformly taut and as tight as possible, true to line and grade and complete in all details. Install tension bars at corners.
4. The fabric shall be fastened to end and corner posts with tension bars and stretcher bar bands spaced at one (1) foot intervals.

E. Stretcher Bars

1. Thread through fabric and secure to posts with approved metal bands spaced not over twelve (12) inches O.C.

F. Wire Ties

1. Wire Ties shall be placed at the intervals indicated on the details and securely fastened to all fence posts.

2. All ties shall be pulled tight as per manufacturer's recommended installation procedure. No sharp edges shall protrude from band-it buckles. Ties will be PVC coated, color to match fabric and framework.

G. Fasteners

1. Install nuts for tension band and hardware bolts on side of fence opposite fabric side unless directed otherwise by the Landscape Architect.

3.03 FINISH PROTECTION

- A. During the fence installation, care shall be taken to avoid damaging the vinyl clad or galvanized surfaces of the fence components. All scratches and abrasions shall be thoroughly corrected in a manner satisfactory to the Landscape Architect before final acceptance.

-END OF SECTION-

SECTION 32 93 00

TREES, SHRUBS, GROUNDCOVERS, AND LANDSCAPING

PART 1 - GENERAL

1.01 WORK INCLUDED:

- A. This Section includes furnishing all labor, materials, equipment, plants, and incidental materials necessary to perform all operations related to the planting of all trees, shrubs, vines, herbaceous plants, ground covers, and for all appurtenant work, complete in place, maintained, and accepted, in accordance with the Contract Drawings and Specifications.
- B. The Contractor shall bear the responsibility and cost of furnishing and applying water or any other substances, as necessary to ensure the sustainability of plant materials, as part of the work of this contract.

1.02 RELATED WORK:

- A. Section 31 05 13.13, LOAM BORROW

1.03 SUBMITTALS:

In accordance with requirements of Section 01 33 23 SUBMITTALS, the Contractor shall submit the following:

- A. Prior to planting, State nursery inspection certificates for all plant materials.
- B. Samples of the manufacturer's product data, as applicable, for the following materials:
 - 1. Limestone.
 - 2. Fertilizer.
 - 3. Sphagnum Peat Moss.
 - 4. Humus.
 - 5. Organic Compost.
 - 6. Manure.
 - 7. Mulch.
 - 8. Guying and Staking Apparatus.
 - 9. Crepe Wrapping for tree trunks.

10. Anti-transpirant/Anti-desiccant.
11. Insecticides.
12. Herbicides.
13. Fungicides.

PART 2 - PRODUCTS

2.01 PLANT MATERIALS:

- A. The Contractor shall furnish and plant all plant materials as shown on the plans and in the quantities and sizes listed thereon. No substitutions shall be permitted without the written approval of the Engineer.
- B. Plants larger than those specified in the Plant List may be used if approved by the Engineer. However, use of such oversized plants shall not be considered grounds for any increase in the contract price. If the use of larger plants is approved, the required spread of roots or ball of earth shall be increased in proportion to the size of the plant and plant pits shall be increased as necessary.
- C. All plants shall be certified to have passed all required Federal and State inspection laws requiring ensuring freedom from plant diseases and insect infestations. The Contractor shall obtain clearance from applicable governing agencies, as required by law, before planting any plants delivered from outside the state in which they are to be planted.
- D. All plants shall be nursery-grown under climatic conditions and environmental stresses similar to those in the locality of the project. All plants shall originate from nurseries that are no more than one Hardiness Zone higher (as established by the Arnold Arboretum, Jamaica Plain, MA) than where the plant is to be installed. Plants also shall conform to the botanical names and standards of size, culture, and quality for the highest grades and standards as adopted by the American Association of Nurserymen, Inc. in the American Standard for Nursery Stock, ANSI-Z60.1, latest edition. All plants shall be legibly tagged with their proper botanical name.
- E. No heeled-in plants or plants from cold storage shall be used. All plants shall be typical of their species or variety and shall have a normal habit of growth. Plants shall be sound, healthy, and vigorous, well branched and densely foliated when in leaf; shall be free of disease, insects, eggs or larvae; and shall have healthy, well-developed root systems. All parts of the plant shall be moist and shall show active green cambium when cut.
- F. All nursery plants shall be balled and burlapped or container-grown and shall have been acclimatized for at least one growing season. Container-grown stock shall have been grown in a container long enough for the root system to have developed sufficiently to hold its soil together, firm and whole, after removal from the container. No plants shall

be loose in the container. Container-grown plants shall have no girdling roots and shall not be in a root-bound condition. Plants shall remain in their container until planted.

- G. Care shall be exercised in digging and preparing field-grown plants for shipment and planting. Balled and burlapped materials shall have solid unbroken balls of earth of sufficient size to encompass all fibrous feeding roots necessary to ensure successful recovery and development of the plants. Balls shall be firmly wrapped in untreated biodegradable burlap and tied securely with wire cages and/or jute twine. Roots or balls of plants shall be adequately protected at all times from sun and drying winds. No plant shall be accepted when the ball of earth surrounding its roots has been badly cracked or broken preparatory to or during planting, or after the burlap, staves, wire cage, rope, or platform in connection with its transplanting have been removed. Soil characteristics (i.e., composition, texture, pH, etc.) of all field-grown plants shall closely match those of the soil where plant materials are to be planted.
- H. The height of the trees, measured from the crown of the roots to the top of the top branch, shall not be less than the minimum size designated in the Plant List in the Drawings. The branching height for deciduous trees installed adjacent to or within walks shall be 7 feet minimum, having been pruned to this height at least 1 year prior to transplanting. Except when a clump is designated, the trunk of each tree shall be a single trunk growing from a single, unmutilated crown of roots. No part of the trunk shall be conspicuously crooked as compared with normal trees of the same variety. The trunk shall be free from sunscald, frost cracks, or wounds resulting from abrasions, fire, or other causes. All pruning cuts shall comply with acceptable horticultural practices. No pruning wounds having a diameter of more than 1½-inches shall be present. Any such wounds must show vigorous bark growth on all edges. Evergreen trees shall be branched to within 1 foot of the ground. No tree that has had its leader cut or die shall be accepted.
- I. Caliper measurements for tree trunks shall be taken 6-inches above ground for trees up to and including 4-inch caliper size and at 12-inches above ground for larger sizes.
- J. Plants shall be delivered only after preparations for planting have been completed. Plants shall be handled and packed in a horticulturally approved manner and all necessary precautions shall be taken to ensure that plants arrive on-site in a healthy vigorous condition. Trucks used for transporting plants shall be equipped with covers to protect plants from windburn, desiccation, and overheating during transport. Plants that have not been thoroughly watered shall not be accepted at the planting site. Any plants delivered to the site in a dry or wilted condition shall be rejected and replaced at no expense to the Owner. All plant materials shall be protected, watered and otherwise maintained prior to, during, and upon delivery to the site.
- K. Plants shall be subject to inspection and approval by the Engineer at the place of growth, or upon delivery, for conformity to specification requirements as to quality, size, variety, and condition. Inspection and selection of plants before digging shall be at the option of the Engineer. The Contractor, or his representative, shall be present, if requested by the Engineer, for inspection of plants at the Nursery. Such approval shall not impair the right of inspection and rejection upon delivery at the site or during the progress of work, for

size and condition of balls and roots, disease, insects and latent defects or injuries. Rejected plants shall be removed immediately from the site. Certificates of inspection of plant materials shall be furnished as may be required by Federal, State and other authorities to accompany shipments.

2.02 LOAM BORROW:

Loam Borrow shall be as specified in Section 31 05 13.13, LOAM BORROW.

2.03 SOIL ADDITIVES AND AMENDMENTS:

A. LIMESTONE:

Lime shall be an approved agricultural limestone containing at least 50 percent total oxides (calcium oxide and magnesium oxide). The material will be ground such that 50 percent of the material will pass through a No. 100 mesh sieve and 98 percent will pass a No. 2 mesh sieve. Lime shall be uniform in composition, dry and free-flowing and shall be delivered to the site in the original sealed containers, each bearing the manufacturer's guaranteed analysis.

B. FERTILIZER:

1. Fertilizer shall be a complete, standard commercial fertilizer, homogeneous and uniform in composition, dry and free-flowing, and shall be delivered to the site in the manufacturer's original sealed containers, each bearing the manufacturer's guaranteed analysis and marketed in compliance with State and Federal Laws. All fertilizer shall be used in accordance with the manufacturer's recommendations.

2. Fertilizer for tree, shrub and groundcover plantings shall contain all major plant nutrients and minor trace elements essential to sustain plant growth and shall have the following analysis:

Nitrogen (N)	Phosphorous (P)	Potassium (K)
10%	10%	10%

3. As approved by the Engineer, a slow release root contact fertilizer installed at the time of planting, may be used in place of the above, at the discretion of the Contractor.

C. Organic Compost shall be a standard commercial product comprised of fully decomposed, 100 percent plant-derived, natural organic matter. Its composition shall furnish ample water holding capacity and cation exchange capacity for the retention of plant nutrients. Compost shall be free of sticks, stones, weed seeds, roots, mineral or other foreign matter and delivered air dry. It shall be free from excessive soluble salts, heavy metals, phytotoxic compounds, and/or substances harmful to plant growth and viability. Organic compost shall have an acidity range of 4.5 to 7.0 pH.

- D. Sphagnum Peat Moss shall be a standard commercial product. Its composition shall furnish ample water holding capacity and cation exchange capacity for the retention of plant nutrients. Peat moss shall be free of sticks, stones, weeds or weed seeds, roots, mineral or other foreign matter. It shall be free from toxic substances and/or compounds harmful to plant growth and viability. It shall be delivered air dry in standard bales and shall have an acidity range of 3.5 to 5.5 pH.
- E. Humus shall be natural humus, reed peat, or sedge peat. Its composition shall furnish ample water holding capacity and cation exchange capacity for the retention of plant nutrients. Humus shall be free of sticks, stones, weeds, roots, mineral or other foreign matter and/or toxic substances harmful to plant growth and viability. It shall be low in wood content, free from hard lumps and excessive amounts of zinc and delivered air dry in a shredded or granular form. The acidity range for humus shall be 5.5 to 7.5 pH, and the organic matter content shall be not less than 85 percent, as determined by loss on ignition. The minimum water holding capacity shall be 200 percent by weight on an oven-dry basis.
- F. Manure shall be well-rotted, leached, cow manure not less than 8 months or more than 2 years old. It shall be free of sawdust, shavings, or refuse of any kind and shall not contain more than 25 percent straw. It shall contain no substances harmful to plant growth. The Contractor shall furnish information regarding chemical disinfectants, if any, that may have been used in storage of the manure.

2.04 PLANTING MIXTURE:

Planting mix shall consist of 7 parts loam borrow and 1 part organic compost, humus, sphagnum peat moss, or manure, thoroughly blended.

2.05 WATER:

Water shall be furnished by the Contractor, unless otherwise specified, and shall be suitable for irrigation and free from ingredients harmful to plant growth and viability. The delivery and distribution equipment required for the application of water shall be furnished by the Contractor, at no additional cost to the Owner.

2.06 MULCH:

Mulch shall be fibrous pliable shredded softbark mulch, not exceeding ½-inch in width. It shall be 98 percent bark, no dyed mulch, with a pH range between 3.5 and 4.5 and a moisture content not to exceed 35 percent. It shall be free of weeds, weed seeds, debris, and other materials harmful to plant growth and viability. Organic mulch shall be aged no longer than 2 years.

2.07 MATERIALS FOR STAKING, GUYING, AND WRAPPING:

- A. Tree stakes shall be sound, untreated 2 x 3 (nominal) x 8-foot length Douglas Fir

reasonably free of knots. No paint or stain shall be used in conjunction with tree stakes. Tying material shall be flexible braided nylon webbing, ¾-inch wide and have a tensile strength of 900 pounds. Webbing shall be ‘ArborTie’, or approved equal.

- B. Drive anchors and guy wire assemblies shall be suitable for protecting trees and shall be sized in accordance with the manufacturer’s recommendations. No materials shall be used for guying that will girdle, chafe, or otherwise injure trees.
- C. Tree wrap shall be duplex, waterproof kraft paper crinkled to 33-1/3 percent stretch, 4 to 6-inch wide strips. Tying materials shall be jute twine, 2-ply for shrubs and trees less than 3-inch caliper; 3-ply for larger plants.

2.08 TREE PAINT:

Tree paint shall not be used.

2.09 ANTI-TRANSPIRANT/ANTI-DESICCANT:

Anti-transpirant or anti-desiccant shall be ‘Wilt-Pruf’, as manufactured by Nursery Specialty Products, Inc., Groton Falls, NY, or approved equal. It shall be delivered in original sealed manufacturer's containers and used in accordance with the manufacturer's instructions.

2.10 INSECTICIDES:

- A. No insecticides shall be used on-site without the Contractor notifying and obtaining the prior approval of the Engineer.
- B. Insecticides shall be EPA registered and approved for use in public open spaces. All insecticides shall be handled by State licensed applicators only, delivered in the original sealed manufacturer’s containers, and used in accordance with the manufacturer’s instructions.
- C. Insecticide use shall be limited and selective, only to control specific insect infestations, as identified by the Contractor or the Owner’s Representative that may result in the disfigurement, decline, or death of plant materials.

2.11 HERBICIDES:

- A. No herbicides shall be used on-site without the Contractor notifying and obtaining prior approval of the Engineer.
- B. Herbicides shall be EPA registered and approved for use in public open spaces. All herbicide shall be handled by State licensed applicators only, delivered in the original sealed manufacturer’s containers, and used in accordance with the manufacturer’s instructions.

- C. Herbicide for post-emergent application shall be glyphosate contact, 'Roundup', as manufactured by Monsanto, Inc., or approved equal.
- D. Herbicide use shall be limited and selective, only to control specific weed infestations that have been identified by the Contractor or the Owner's Representative.

2.12 FUNGICIDES:

- A. No fungicides shall be used on-site without the Contractor notifying and obtaining prior approval of the Engineer.
- B. Fungicides shall be EPA registered and approved for use in public open spaces. All fungicides shall be handled by State licensed applicators only, delivered in the original sealed manufacturer's containers, and used in accordance with the manufacturer's instructions.
- C. Fungicide use shall be limited and selective, only to control specific fungal pathogenic disease infestations, as identified by the Contractor or the Owner's Representative, that may result in the disfigurement, decline, or death of plant materials.

PART 3 - EXECUTION

3.01 INSTALLATION:

- A. All plants shall be subject to inspection and approval by the Engineer upon delivery to the site. No materials shall be planted until approval is received.
- B. All work shall be performed by skilled workers with a minimum of 2 years planting experience, in accordance with accepted horticultural/nursery practices, under the full-time supervision of a Certified Nurseryman or Arborist.
- C. All balled and burlapped plants that cannot be planted immediately upon delivery shall be set on the ground and the root balls shall be well protected with soil, wet moss, or other acceptable material. All foliage shall be protected and covered with perforated shade materials.
- D. The planting season for evergreen trees and shrubs shall extend from the time the soil becomes workable in the spring until new growth appears, and from September 15 until November 30 in the fall. Deciduous trees and shrubs shall be planted only when dormant, either prior to bud break and/or before leaves appear in the spring, or subsequent to their leaf drop in the fall. Planting season periods may be extended if weather and soil conditions permit only with the written approval of the Engineer. Extended or out-of-season planting requirements shall include application of antitranspirant and extra water as needed. Plant guarantee periods shall remain as stated below. Planting shall not be permitted in frozen ground.
- E. All plant locations and outlines for planting beds shall be staked out for review and

potential adjustment by the Engineer before any excavation is begun. In the event that rock, underground construction work or obstructions are encountered in any proposed planting pit or bed, the Engineer may select alternate locations. Where locations cannot be changed, the obstruction shall be removed, subject to the Engineer's approval, to a depth of not less than 3 feet below grade and not less than 6-inches below the bottom of the root ball when plant is properly set at the required grade. Removal of boulders or obstructions greater than 1 cubic yard in size shall be subject to approval and will be paid for by the Owner. No ledge will be removed to create planting pits or beds

- F. All planting pits shall be excavated with sloped walls, wider at the top than at the bottom, and scarified to eliminate glazing. Tree pits shall be at least 2 feet greater in diameter than the root ball of earth or root system. Shrub pits shall be at least 1 foot greater than the diameter of the root ball. Planting pits shall not be deeper than the height of the root ball.
- G. When excavation occurs in areas of heavily compacted earth, stones, concrete chunks or other foreign matter, pits shall be dug at least 3 times the width of the rootball. Excavated material from plant pits shall be disposed of as required.
- H. Container plants shall be removed from their growing container before planting. If roots are densely matted, the outer root mass shall be scored, sliced vertically, with a sharp knife to separate roots.
- I. Shrubs and trees shall be set in the center of planting pits, plumb and straight, and at such a level that after settlement the crown of the roots will be 1-inch above the surrounding finished grade. Root ball masses shall not be loosened, broken or damaged. When balled and burlapped plants are set, planting mixture shall be compacted around bases of balls to fill all voids. All tying materials, twine and rope shall be cut and removed. Biodegradable burlap shall be laid back or cut away from the top half of the ball. If a wire basket is present, the upper 2/3 of the basket shall be cut away and removed. Do not remove the entire basket. Roots or bare root plants shall be properly spread out and planting mixture carefully worked in among them. Broken or frayed roots shall be cleanly cut.
- J. Backfill plant pits with planting mixture in layers of not more than 9-inches and firmly tamp each layer and water to sufficiently settle the backfilled soil before the next layer is put in place. When the planting pit is 2/3 backfilled, the hole shall be flooded and watered thoroughly so that the water level reaches the top of the planting pit. Allow water to soak in, then complete the backfilling operation. Immediately after planting pit is backfilled, a shallow basin 3-inches deep and slightly larger than the pit shall be formed with a ridge of soil for water retention. Form a common basin for plant materials throughout mass planting beds. After planting, lightly till the soil in planting beds between planting pits and rake smooth to eliminate compaction of soils.
- K. All planting hole basins shall be flooded with water twice within the first 24 hours of planting, and watered not less than twice per week until final acceptance of the work.

- L. All thin barked deciduous trees shall be wrapped after they are planted and before they are staked. Prior to wrapping, inspect trees for injury to trunks or improper pruning. Take corrective measures as necessary. Wrap trunks of all trees spirally from bottom to top with tree wrap and secure top and bottom at 2-foot intervals with jute twine. The wrapping shall overlap and entirely cover the trunk from the ground to the height of the second branches and shall be neat and snug. Overlap shall be approximately 2-inches.
- M. Stake trees immediately after planting as detailed. All staking apparatus shall be adequate to hold the tree in a vertical position under severe weather conditions. All staking apparatus and tree trunk wrapping shall be removed and disposed of off-site by the Contractor at the end of one growing season.
- N. Immediately after planting and staking operations are complete, all plant pit basins and plant beds shall be covered with approved mulch to the depths designated on the plans. Mulch shall not contact tree bark, cover tree root flares, or shrub crowns. No mulch shall be applied prior to the first watering.
- O. The pruning of trees and shrubs shall only be permitted to remove dead or dying branch limbs and tips, sucker growth, water sprouts, crossing or rubbing branches, broken or damaged branches, diseased or insect infested limbs, and to preserve the natural character of the plant. Plant materials shall be pruned in accordance with American Nurserymen Association Standards and as required by the Engineer. Questionable weak limbs and branch removals that may disfigure the plant shall be left to the discretion of the Engineer. The tree leader shall never be permitted to be cut. Pruning shall be done with clean, sharp tools. All large pruning cuts that are ½-inch in diameter or larger shall be made along the bark branch ridge. Pruning cuts shall not breach or otherwise interfere with the branch collar. All pruning cuts less than ¼-inch diameter shall be made with hand pruners as close to the main stem as possible without damaging the cambium or bud. Tree paint shall not be used to cover pruning cuts.
- P. As the work proceeds, the Contractor shall remove all debris from the site, including but not limited to branches, rock, paper, and rubbish. All areas shall be kept clean, neat and in an orderly condition at all times. Prior to final acceptance, the Contractor shall cleanup the entire area to the satisfaction of the Engineer.

3.02 MAINTENANCE:

- A. Maintenance shall begin immediately after each plant is planted and shall continue until completion of the guarantee period and final acceptance of the project. Plants shall be watered, pruned, sprayed, fertilized, cultivated and otherwise maintained and protected. Tree guys and stakes shall be tightened and repaired. Defective work shall be corrected as soon as possible after it becomes apparent and weather and season permit.
- B. Settled plants shall be reset to proper grade and position, planting pits and common basins restored, and dead materials removed and replaced. Planting beds and individual basins shall be neat in appearance, maintained to their original layout lines and kept free of weeds. Mulch shall be replaced as required to maintain proper depths.

- C. Contractor shall make arrangements to provide sufficient water to maintain all trees, shrubs and plant materials until final acceptance. Plants shall be sprayed with anti-transpirant or anti-desiccant if required by seasonal conditions or as required by the Engineer.
- D. Planting areas shall be protected against trespass and damage of any kind during the maintenance period. This shall include the furnishing and installation of approved temporary fencing if necessary. If any plants become damaged during the maintenance period, they shall be treated or replaced as required by the Engineer at no additional cost to the Owner.

3.03 INSPECTION AND PRELIMINARY ACCEPTANCE:

- A. Contractor shall provide written notice to the Engineer not less than 10 days before the anticipated date of inspection for preliminary acceptance. The Engineer shall recommend preliminary acceptance of the work of this Section only after completion and re-inspection of all necessary repairs, renewals or replacements.
- B. Inspection and acceptance of plantings may be requested and granted in part, provided the areas for which acceptance is requested are relatively substantial in size, and with clearly definable boundaries. Acceptance and use of these areas by the Owner shall not waive any other provisions of this Contract.

3.04 GUARANTEE:

- A. All plant materials shall be guaranteed for a period of one year after the date of completion of the specified maintenance period and preliminary acceptance of the project by the Owner.
- B. When the work is accepted in part, the guarantee period shall extend from each partial acceptance to the terminal date of the last guarantee period. All guarantee periods terminate at one time.
- C. Plants shall be healthy, free of pests and disease. Plants shall exhibit vigorous growth, shall bear foliage of normal density, size and color and shall have no less than seventy-five percent (75%) of their branches alive at the end of the guarantee period. If the leader of any single-leader species is dead, the entire plant shall be considered dead.
- D. Any plant required under this Contract that is dead or unsatisfactory, as determined by the Engineer, shall be removed from the site. These shall be replaced as soon as weather permits during the specified planting season, at no additional cost to the Owner, until the plants live through one year.
- E. All replacements shall be plants of the same kind and size as specified on the Plant List. They shall be furnished and planted as specified above.

- F. The guarantee of all replacement plants shall extend for an additional one-year period from the date of their acceptance as replacement.
- G. Guarantee shall not apply to the replacement of unacceptable plants resulting from the removal, loss, or damage due to occupancy of the project in any part; vandalism or acts of neglect on the part of others; physical damage by animals, vehicles, etc.; and Acts of God, including but not limited to, catastrophic fire, hurricanes, riots, war, etc.
- H. In the instance of curtailment of water by local water authorities (when supply was to be furnished by the Owner), the Contractor shall furnish all necessary water by water tanker, the cost of which will be approved and paid for by the Owner.

3.05 FINAL INSPECTION AND FINAL ACCEPTANCE:

- A. At the end of the guarantee period, the Contractor shall provide written notice to the Engineer not less than 10 days before the anticipated date of final inspection for final acceptance.
- B. The Engineer shall recommend final acceptance of the work of this Section only after completion and re-inspection of all necessary repairs, renewals or replacements.

END OF SECTION

SECTION 32 96 43

TREE TRANSPLANTING

PART 1 - GENERAL

1.01 SUMMARY

- A. Section includes transplanting non-nursery-grown trees, by tree spade or digging, balling and burlaping.
- B. RELATED WORK:
 - 1. Section 32 93 00 TREES, SHRUBS, GROUND COVER AND LANDSCAPING

1.02 DEFINITIONS

- A. General: See definitions in ANSI A300 (Part 6) and in ANSI Z60.1 pertaining to field-grown trees, except as otherwise defined in this Section.
- B. Caliper: Diameter of a trunk as measured by a diameter tape at a height 6 inches (150 mm) above the root flare for trees up to, and including, 4-inch (100-mm) size at this height; and as measured at a height of 12 inches (300 mm) above the root flare for trees larger than 4-inch (100-mm) size.
- C. Caliper (DBH): Diameter breast height; diameter of a trunk as measured by a diameter tape at a height 54 inches (1372 mm) above the ground line for trees with caliper of 8 inches (200 mm) or greater as measured at a height of 12 inches (300 mm) above the root flare.
- D. Root-Ball Depth: Measured from bottom of trunk flare to the bottom of root ball.
- E. Root-Ball Width: Measured horizontally across the root ball with an approximately circular form or the least dimension for non-round root balls, not necessarily centered on the tree trunk, but within tolerance according to ANSI Z60.1.
- F. Root Flare: Also called "trunk flare." The area at the base of the tree's stem or trunk where the stem or trunk broadens to form roots; the area of transition between the root system and the stem or trunk.

1.2 PREINSTALLATION MEETINGS

- A. Preinstallation Conference: Conduct conference at Project site.

1. Review methods and procedures related to transplanting work include, but are not limited to, the following:
 - a. Construction schedule. Verify availability of materials, personnel, equipment, and unimpeded access needed to make progress and avoid delays.
 - b. Tree and plant protection.
 - c. Tree maintenance.
 - d. Arborist's responsibilities.

1.3 SUBMITTALS

- A. Product Data: For each type of product.
- B. Samples for Verification: For each of the following:
 1. Weed-control barriers.
 2. Root-Ball-Stabilization Device: One unit.
 3. Slow-Release Watering Device:
- C. Pruning Schedule: Written schedule prepared by arborist detailing scope and extent of pruning each tree in preparation for and subsequent to transplanting.
 1. Species and size of plant.
 2. Location on site plan. Include unique identifier for each.
 3. Reason for pruning.
 4. Seasonal limitations on pruning.
 5. Preparatory Pruning: Time schedule and description of preparatory pruning to be performed.
 - a. Indicate time in months preceding the extraction of the tree.
 - b. Indicate diameter of root ball and depth of root pruning for the tree.
 6. Description of root and crown pruning during and subsequent to transplanting.
 7. Description of maintenance following pruning.
- D. Qualification Data: For qualified tree-service firm and arborist.
- E. Certification: From arborist, certifying that transplanted trees have been protected during construction and that trees were promptly and properly treated and repaired when damaged.
- F. Maintenance Recommendations: From arborist, recommended procedures to be established by Owner for care and protection of trees after completing the Work.
 1. Submit before completing the Work.

- G. Existing Conditions: Documentation of existing trees indicated to be transplanted, which establishes preconstruction conditions that might be misconstrued as damage caused by construction activities.
 - 1. Use sufficiently detailed color photographs or video recordings. Color shall accurately depict hue condition of foliage and bark.
 - 2. Include drawings and notations to indicate specific wounds and damage conditions of each tree designated to be transplanted.
- H. Tree-Transplanting Program: Submit before work begins.
- I. Sample Warranties: For special warranties.
- J. Tree-maintenance reports.

1.4 QUALITY ASSURANCE

- A. Tree-Service Firm Qualifications: An experienced landscaping contractor or tree-moving firm that has successfully completed transplanting work similar to that required for this Project and that will assign an experienced, qualified arborist to Project site during execution of the Work.
- B. This work shall be limited to individuals, partnerships and corporations who are actively engaged in the field of Arboriculture, and who demonstrate competence, experience and financial capability to carry out the terms of this project. Eligible contractors must derive a majority of their income from arboricultural work. The Owner may require proof of these qualifications.
- C. All work shall be conducted by qualified and trained personnel under the direct supervision of a Massachusetts Certified Arborist (MCA) in the Contractor's employ.
- D. Tree-Transplanting Program: Prepare a written plan by arborist for transplanting trees for the whole Project, including each phase or process, tree maintenance, and protection of surrounding materials during operations. Describe in detail the materials, methods, and equipment to be used for each phase of the transplanting work.
 - 1. Include transplanting times appropriate for each species at the Project location unless otherwise indicated on Drawings.
 - 2. Include a transplanting schedule for each species to be transplanted, coordinated with the Project schedule.
 - 3. Include site plans clearly marked to show tree-moving routes from extraction to planting locations. Indicate proposed equipment, weight, and turning radii.
 - 4. Show details of temporary protective barriers where needed.
 - 5. Include diagrams showing clearances to utility lines and other encumbrances along route.
 - 6. Include care and maintenance provisions and eventual removal of tree stabilization.

1.5 HANDLING

- A. Packaged Materials: Deliver packaged materials in original, unopened containers showing weight, certified analysis, name and address of manufacturer, and indication of conformance with state and federal laws if applicable.
- B. Protect bark, branches, and root systems from sun scald, drying, wind burn, sweating, whipping, and other handling and tying damage. Do not bend or bind-tie trees in such a manner as to destroy their natural shape.
- C. Protect foliage when transporting trees while they are in foliage.
- D. Handle tree by root ball. Do not drop trees.
- E. Move tree after preparations for planting have been completed, and install immediately. If planting is delayed more than six hours after moving, set tree in their appropriate aspect (sun, filtered sun, or shade), protect from weather and mechanical damage, and keep roots moist.

1.6 FIELD CONDITIONS

- A. Field Measurements: Verify final grade elevations and final locations of trees and construction contiguous with trees by field measurements before proceeding with transplanting work. Perform transplanting only after finish grades are established.
- B. Seasonal Restrictions: Transplant trees during the following in-season periods:
 - 1. As determined by Arborist.
- C. Weather Limitations: Proceed with transplanting only when existing and forecasted weather conditions permit planting to be performed when beneficial and optimum results may be obtained. Do not transplant during excessively wet or frozen conditions. Apply products during favorable weather conditions according to manufacturer's written instructions and warranty requirements.
- D. Coordination with Planting Beds: Perform transplanting before planting bedded areas unless otherwise indicated.
 - 1. When transplanting after planting bedded areas, protect bedding plants, and promptly repair damage caused by transplanting operations.

1.7 WARRANTY

- A. Installer's Special Warranty: Tree-service firm agrees to repair or replace trees and related materials that fail within specified warranty period.
 - 1. Failures include, but are not limited to, the following:

- a. Death and unsatisfactory growth except for defects resulting from abuse, lack of adequate maintenance, or neglect by Owner, or incidents that are beyond Contractor's control.
 - b. Death and unsatisfactory growth is defined as more than 25 percent dead or in an unhealthy condition or failure to meet general performance requirements at end of warranty period.
 - c. Structural failures including trees falling or blowing over.
 - d. Faulty performance of materials and devices related to tree plantings including tree stabilization.
2. Warranty Periods from Date of Substantial Completion.
- a. Tree: 12 months.
3. Include the following remedial actions as a minimum:
- a. Remove dead trees and trees with unsatisfactory growth at end of warranty period; replace when directed.
 - b. A limit of one replacement of each tree will be required except for losses or replacements due to failure to comply with requirements.
 - c. Replace materials and devices related to tree plantings.
 - d. Provide extended warranty for period equal to original warranty period, for replaced trees.

1.8 MAINTENANCE SERVICE

- A. Initial Maintenance Service: Provide tree maintenance by skilled employees of tree-service firm and as required in Part 3. Begin maintenance immediately after trees are installed and continue until plantings are healthy and well established but for not less than maintenance period below.
 - 1. Maintenance Period: 12 months from date of Substantial Completion.
- B. Continuing Maintenance Proposal: From tree-service firm to Owner, in the form of a standard yearly (or other period) maintenance agreement, starting on date initial maintenance service is concluded. State services, obligations, conditions, and terms for agreement period and for future renewal options.

PART 2 - PRODUCTS

2.1 PERFORMANCE REQUIREMENTS

- A. General Performance: Transplanted trees shall be healthy and resume vigorous growth within one year of transplanting without dieback due to defective extracting, handling, planting, maintenance, or other defects in the Work.

2.2 PLANTING MATERIALS

- A. Backfill Soil: Planting soil of suitable moisture content and granular texture for placing and compacting in planting pit around tree, and free of stones, roots, plants, sod, clods, clay lumps, pockets of coarse sand, concrete slurry, concrete layers or chunks, cement, plaster, building debris, and other extraneous materials harmful to plant growth.
 - 1. Planting Soil: Planting soil as specified in 32 93 00 TREES, SHRUBS, GROUND COVER AND LANDSCAPING

2.3 TREE-STABILIZATION MATERIALS

- A. Trunk-Stabilization Materials:
 - 1. Upright and Guy Stakes: Rough-sawn, sound, new hardwood, free of knots, holes, cross grain, and other defects, 2-by-2-inch nominal (38-by-38-mm actual) by length indicated, pointed at one end.
 - 2. Flexible Ties: Wide rubber or elastic bands or straps.
 - 3. Guys and Tie Wires: ASTM A 641/A 641M, Class 1, galvanized-steel wire, two-strand, twisted, 0.106 inch (2.7 mm) in diameter.
 - 4. Tree-Tie Webbing: UV-resistant polypropylene or nylon webbing with brass grommets.
 - 5. Flags: Standard surveyor's plastic flagging tape, white, 6 inches (150 mm) long.
 - 6. Proprietary Staking-and-Guying Devices: Proprietary stake and adjustable tie systems to secure each new planting by tree stem; sized as indicated and according to manufacturer's written instructions.
 - a. Products: Subject to compliance with requirements, provide one of the following:
 - 1) Anchor Tie Down Systems, Inc.; Twister Tie Down.
 - 2) Arborbrace; Arborbrace Tree Guying System.
 - 3) Deep Root Partners, L.P.; ArborTie.
 - 4) J. R. Partners; R2 Stake, Mega Stake, U-Stake System.

2.4 MISCELLANEOUS PRODUCTS

- A. Mulch as specified in Section 32 93 00 TREES, SHRUBS, GROUND COVER AND LANDSCAPING.
- B. Antidesiccant: Water-insoluble emulsion, permeable moisture retarder, film forming, for trees. Deliver in original, sealed, and fully labeled containers and mix according to manufacturer's written instructions.
- C. Burlap: Non-synthetic, biodegradable.

- D. Pesticides: Pesticide registered and approved by EPA, acceptable to authorities having jurisdiction, and of type recommended in writing by manufacturer for each specific problem and as required for Project conditions and application. Do not use restricted pesticides unless authorized in writing by authorities having jurisdiction.
 - 1. Pre-Emergent Herbicide (Selective and Non-Selective): Effective for controlling the germination or growth of weeds within planted areas at the soil level directly below the mulch layer.
 - 2. Post-Emergent Herbicide (Selective and Non-Selective): Effective for controlling weed growth that has already germinated.

- E. Planting Tablets: Tightly compressed chip type, long-lasting, slow-release, commercial-grade planting fertilizer in tablet form. Tablets shall break down with soil bacteria, converting nutrients into a form that can be absorbed by plant roots.
 - 1. Size: 21-gram tablets.
 - 2. Nutrient Composition: 20 percent nitrogen, 10 percent phosphorous, and 5 percent potassium, by weight plus micronutrients.

PART 3 - EXECUTION

3.1 TREE-TRANSPLANTING SPECIALIST

- A. Tree-Transplanting Specialist Firms: Subject to compliance with requirements, have tree transplanting performed by one of the following firms:
 - 1. As proposed by Contractor and approved by Owner.

3.2 EXAMINATION

- A. Erosion and Sedimentation Control: Examine the site to verify that temporary erosion- and sedimentation-control measures are in place. Verify that flows of water redirected from construction areas or generated by construction activity do not enter or cross transplanting areas.
- B. For the record, prepare written report, endorsed by arborist, listing conditions detrimental to transplanting work and tree protection and health.
- C. Proceed with transplanting only after unsatisfactory conditions have been corrected.

3.3 PREPARATION

- A. Protect structures, utilities, sidewalks, pavements, other facilities, and other plants and planting areas from damage caused by transplanting operations.

- B. Utility Locator Service: Notify utility locator service for area where Project is located before beginning excavation.
- C. Locate and clearly identify tree for transplanting. Tie a 1-inch (25-mm) blue-vinyl tape around each tree.
- D. Retain first paragraph below if locations of plantings are not shown on Drawings or if final adjustment is required.
- E. Lay out individual transplant locations and areas for multiple plantings. Stake locations, outline areas, adjust locations when requested, and obtain Architect's acceptance of layout before transplanting. Make minor adjustments as required.
- F. Apply antidesiccant to trees uniformly, using power spray to provide an adequate film over trunks (before wrapping), branches, stems, twigs, and foliage to protect during extracting, handling, and transportation.
 - 1. If deciduous trees are moved in full leaf, spray with antidesiccant before extracting and again two weeks after transplanting.
- G. Wrap trees with burlap fabric over trunks, branches, stems, twigs, and foliage to protect from wind and other damage during extracting, handling, and transporting.

3.4 PREPARATORY PRUNING

- A. Root Pruning: Perform preparatory root pruning under direction of arborist as far in advance of extracting each tree as the Project Schedule allows.
 - 1. Dig exploratory pits or trench by hand or with air spade around perimeter of tree at indicated root-ball width to determine locations of main lateral roots.
 - 2. Dig trench by hand or with tree spade around perimeter of tree at indicated root-ball width to the depth of the root system. Do not use a backhoe or other equipment that rips, tears, or pulls roots.
 - 3. Root-Ball Width: Minimum 10 inches (250 mm) of root-ball diameter or least dimension for non-round root balls, for each inch (25 mm) of tree caliper being transplanted.
 - 4. If encountering large, main lateral roots, expose roots beyond excavation limits as required to bend and redirect them without breaking.
 - 5. Use narrow-tine spading forks to comb soil to expose roots with minimal damage to root system.
 - 6. Cut exposed roots manually with sharp pruning instruments; do not break, tear, chop, or slant the cuts. Do not use a backhoe or other equipment that rips, tears, or pulls roots.
 - 7. Do not paint or apply sealants on cut root ends.
 - 8. Backfill trench with excavated soil.
- B. Crown Pruning (Tip Pruning):

1. Perform preparatory crown pruning as directed by arborist. Follow procedures as specified in "Crown Pruning" Article.

3.5 EXCAVATION AND PLANTING EQUIPMENT

- A. Tree Spade: Track-mounted mechanized tree mover; sized according to manufacturer's size recommendation for each tree being transplanted.

3.6 EXCAVATING PLANTING PITS

- A. General: Excavate under supervision of the arborist.
 1. Excavate planting pits or trenches with sides sloping. Trim perimeter of bottom leaving center area of bottom raised slightly to support root ball and assist in drainage away from center. Do not further disturb base. Ensure that root ball will sit on undisturbed base soil. Scarify sides of planting pit smeared or smoothed during excavation.
 2. Excavate approximately two times as wide as root ball.
 3. Keep excavations covered or otherwise protected until replanting trees.
- B. Subsoil and topsoil removed from excavations may not be used as planting soil.
- C. Obstructions: Notify Landscape Architect if unexpected rock or obstructions detrimental to trees are encountered in excavations.
 1. Hardpan Layer: Drill 6-inch- (150-mm-) diameter holes, 24 inches (600 mm) apart, into free-draining strata or to a depth of 10 feet (3 m), whichever is less, and backfill with free-draining material.
- D. Seepage: Notify Architect if subsoil conditions evidence unexpected water seepage into tree-planting pits.
- E. Drainage: Fill planting pit or trench with 6 inches (152 mm) of water and time the infiltration rate of the soil. If the drainage rate is less than 0.25 inch (6 mm) per hour, notify Architect to determine need for subsurface drainage.
- F. Saline or Sodic Soils: Completely fill excavations with water and allow to percolate away before positioning trees.

3.7 EXTRACTING TREES

- A. General: Extract trees under supervision of the arborist.
- B. Orientation Marking: Mark the north side of each tree with non-permanent paint before extracting.

- C. Root-Ball Width: Minimum 10 inches (250 mm) of root-ball diameter or least dimension for non-round root balls, for each inch (25 mm) of tree caliper being transplanted.
 - 1. Out-of-Season Planting: If planting before or after the in-season period for tree, provide a minimum root-ball diameter of 12 inches (305 mm) for each inch (25 mm) of tree caliper being transplanted.
- D. Root-Ball Depth: As determined by the arborist for each species and size of tree and for site conditions at original and planting locations.
- E. Digging:
 - 1. Dig and clear a pit by hand or with tree spade to the depth of the root system. Do not use a backhoe or other equipment that rips, tears, or pulls roots.
 - 2. Use narrow-tine spading forks to comb soil to expose roots with minimal damage to root system.
 - 3. If encountering large, main lateral roots, expose roots beyond excavation limits as required to bend and redirect them without breaking.
 - 4. Cut exposed roots manually with sharp pruning instruments; do not break, tear, chop, or slant the cuts. Do not paint or apply sealants on cut root ends.
 - 5. Completely wrap ball in burlap and secure with suitably-sized twine or wire according to ANSI Z60.1 Brace and support to prevent breaking of root ball.
 - 6. Temporarily support and protect exposed roots from damage until they are permanently redirected and covered with soil. Cover roots with burlap and keep them moist until planted.
- F. Extracting with Tree Spade: Use the same tree spade to extract the tree as will be used to transport and plant the tree.
 - 1. Do not use tree spade to move trees larger than the manufacturer's maximum size recommendation for the tree spade being used.
 - 2. When extracting the tree, center the trunk within the tree spade and move tree with a solid ball of earth.

3.8 PLANTING

- A. Planting Standard: Perform planting according to ANSI A300 (Part 6) unless otherwise indicated.
- B. Before planting, verify that root flare is visible at top of root ball. If root flare is not visible, remove soil in a level manner from the root ball to where the top-most root emerges from the trunk. After soil removal to expose the root flare, verify that root ball still meets size requirements.
- C. Ensure that root flare is visible after planting.

- D. Remove injured roots by cutting cleanly; do not break. Do not paint or apply sealants on cut root ends.
- E. Orientation: Position the tree so that its north side, marked before extracting, is facing north in its new location.
- F. Set tree plumb and in center of planting pit with bottom of root flare 1 inch (25 mm) above adjacent finish grades.
 - 1. Use specified backfill soil for backfill.
 - 2. If area under the tree was initially dug too deep, add backfill to raise it to the correct level and thoroughly tamp the added soil to prevent settling.
 - 3. After placing some backfill around root ball to stabilize plant, begin backfilling.
 - 4. Backfill around root ball in layers, tamping to settle soil and eliminate voids and air pockets. When planting pit is approximately one-half filled, water thoroughly before placing remainder of backfill. Repeat watering until no more water is absorbed.
 - 5. Redirect exposed root ends downward in backfill areas where possible. Hand-expose roots as required to bend and redirect them without breaking. If encountered immediately adjacent to location of new construction and redirection is not practical, cut roots approximately 3 inches (75 mm) back from new construction and as required for root pruning.
 - 6. Place planting tablets in each planting pit when pit is approximately one-half filled; in amounts recommended by arborist. Place tablets beside the root ball about 1 inch (25 mm) from root tips; do not place tablets in bottom of the hole.
 - 7. Continue backfilling process. Water again after placing and tamping final layer of soil.
- G. Planting with Tree Spade: Use the same tree spade for planting as was used to extract and transport the tree. Do not use tree spade for trees larger than the manufacturer's maximum size recommendation for the tree spade being used.
- H. Slopes: When planting on slopes, set the tree so the root flare on the uphill side is flush with the surrounding soil on the slope; the edge of the root ball on the downhill side will be above the surrounding soil. Apply enough soil to cover the downhill side of the root ball.

3.9 CROWN PRUNING

- A. Prune branches as directed by arborist.
 - 1. Prune to remove injured, broken, dying, or dead branches.
 - 2. Remove or reduce living branches to compensate for root loss caused by cutting root system.
 - 3. Pruning Standards: Perform pruning according to ANSI A300 (Part 1).
- B. Unless otherwise directed by arborist and acceptable to Architect, do not cut tree leaders.

- C. Cut branches with sharp pruning instruments; do not break or chop.
- D. Do not paint or apply sealants to wounds.
- E. Provide subsequent maintenance during Contract period as recommended by arborist.
- F. Chip removed branches and dispose of off-site.

3.10 TREE STABILIZATION

- A. Trunk Stabilization by Upright Staking and Tying: Install trunk stabilization as follows unless otherwise indicated on Drawings or directed by arborist.
 - 1. Upright Staking and Tying: Stake only as required to prevent wind tip out. Use a minimum of three stakes of length required to penetrate at least 18 inches (450 mm) below bottom of backfilled excavation and to extend one-third of trunk height above grade. Set stakes vertical and space to avoid penetrating root balls or root masses.
 - 2. Support trees with bands of flexible ties at contact points with tree trunk. Allow enough slack to avoid rigid restraint of tree.
 - 3. Support trees with two strands of tie wire, connected to the brass grommets of tree-tie webbing at contact points with tree trunk. Allow enough slack to avoid rigid restraint of tree.

3.11 MULCHING

- A. Mulch as specified in Section 32 93 00 TREES, SHRUBS, GROUND COVER AND LANDSCAPING.

3.12 TREE MAINTENANCE

- A. Perform tree maintenance as recommended by arborist. Maintain arborist observation of transplanting work.
- B. Maintain trees by pruning, cultivating, watering, weeding, fertilizing, mulching, restoring planting saucers, adjusting and repairing tree-stabilization devices, resetting to proper grades or vertical position, and performing other operations as required to establish healthy, viable plantings. Treat as required to keep trees free of insects and disease.
- C. From time of tree extraction measure soil moisture adjacent to edge of each root ball bi-weekly. Record findings and weather conditions.
- D. Fill areas of soil subsidence with backfill soil. Replenish mulch materials damaged or lost in areas of subsidence.

- E. Apply treatments as required to keep tree materials, planted areas, and soils free of pests and pathogens or disease. Use integrated pest management practices whenever possible to minimize the use of pesticides and reduce hazards. Treatments include physical controls such as hosing off foliage, mechanical controls such as traps, and biological control agents.
- F. Pesticide Application: Apply pesticides and other chemical products and biological control agents in accordance with authorities having jurisdiction and manufacturer's written instructions. Coordinate applications with Owner's operations and others in proximity to the Work. Notify Owner before each application is performed.
 - 1. Pre-Emergent Herbicides (Selective and Non-Selective): Apply in accordance with manufacturer's written instructions. Do not apply to seeded areas.
 - 2. Post-Emergent Herbicides (Selective and Non-Selective): Apply only as necessary to treat already-germinated weeds and in accordance with manufacturer's written instructions.
- G. Reports: Have arborist prepare monthly inspection reports.

3.13 REPAIR AND REPLACEMENT

- A. General: Repair or replace transplanted trees and other plants indicated to remain or be relocated that are damaged by construction operations, in a manner recommended by the arborist and approved by Architect.
 - 1. Submit details of proposed pruning and repairs.
 - 2. Perform repairs of damaged trunks, branches, and roots within 24 hours according to arborist's written instructions.
 - 3. Replace trees and other plants that cannot be repaired and restored to full-growth status, as determined by Architect.
- B. Remove and replace trees that are more than 25 percent dead or in an unhealthy condition before the end of the corrections period or are damaged during construction operations that Architect determines are incapable of restoring to normal growth pattern.
 - 1. Provide new trees of same size as those being replaced for each tree of 6 inches (150 mm) or smaller in caliper size.
 - 2. Provide two new trees of 4-inch (100-mm) caliper size for each tree being replaced that measures more than 6 inches (150 mm) in caliper size.
 - 3. Species of Replacement Trees: Same species being replaced.

3.14 CLEANUP AND PROTECTION

- A. During transplanting, keep adjacent paving and construction clean and work area in an orderly condition.

- B. Protect trees from damage due to transplanting operations and operations of other contractors and trades. Maintain protection during transplanting and maintenance periods. Treat, repair, or replace damaged plantings.
- C. After planting and at end of Warranty Period, remove stakes, tags, markings, tie tape, labels, wire, burlap, and other debris from transplanted trees, planting areas, and Project site.

3.15 DISPOSAL OF SURPLUS AND WASTE MATERIALS

- A. Except for materials indicated to be recycled, remove surplus soil, excess excavated material, waste materials, displaced plants, trash, and debris, and legally dispose of them off Owner's property.

END OF SECTION

SECTION 33 05 26.13

TRACER TAPE

PART 1 - GENERAL

1.01 WORK INCLUDED:

This section covers the furnishing, handling and installation of tracer tape, as called for on the drawings.

1.02 SUBMITTALS: IN ACCORDANCE WITH REQUIREMENTS OF SECTION 01 33 23 SUBMITTALS, SUBMIT THE FOLLOWING:

- A. Manufacturer's literature on the materials, colors and printing specified herein, shall be submitted to the Engineer for review.
- B. Tape samples shall also be submitted to the Engineer for review.

PART 2 - PRODUCTS

2.01 ACCEPTABLE MANUFACTURERS:

Tracer tape shall be by Reef Industries, Houston, TX; Empire Level, Mukwonago, WI; Pro-Line Safety Products Co., W. Chicago, IL; or approved equal.

2.02 TRACER TAPE:

- A. Tracer tape shall be at least 3-inches wide.
- B. Tracer tape for non-ferrous pipe or conduit shall be constructed of a metallic core bonded to plastic layers. The metallic tracer tape shall be a minimum 5-mil thick and must be locatable at a depth of 18-inches with ordinary pipe locaters.
- C. Tracer tape for ferrous pipe or conduit shall consist of multiple bonded plastic layers. The non-metallic tracer tape shall elongate at least 500% before breaking.
- D. The tape shall bear the wording: "BURIED DRAIN LINE BELOW" (with "DRAIN" replaced by "WATER", "SEWER", "ELECTRICAL", "GAS", "TELEPHONE", or "CHEMICAL" as appropriate), continuously repeated every 30-inches to identify the pipe.
- E. Tape colors shall be as follows, as recommended by the American Public Works Association (APWA):

Electric	Red
Gas & Oil	Yellow
Communications	Orange

Water	Blue
Sewer & Drain	Green
Chemical	Red (not APWA)

PART 3 - EXECUTION

3.01 INSTALLATION:

- A. Tracer tape shall be installed directly above the pipe or conduit it is to identify, approximately 12-inches below the proposed ground surface.
- B. The Contractor shall follow the manufacturer's recommendations for installation of the tape, as approved by the Engineer.

END OF SECTION

SECTION 33 31 13.46

CONNECTIONS TO EXISTING STRUCTURES

PART 1 - GENERAL

1.01 WORK INCLUDED:

The Contractor shall furnish materials, tools, labor and equipment to cut suitable openings into the existing manholes, make connections to existing drains and all other work necessary to direct the existing drainage flow as indicated on the drawings and as herein specified.

1.04 SUBMITTALS: IN ACCORDANCE WITH REQUIREMENTS OF THE GENERAL SPECIFICATIONS, SUBMIT THE FOLLOWING:

Prior to start of work, submit details of the methods proposed for doing the work and for maintaining the drainage flow as herein specified.

PART 2 - PRODUCTS - NOT APPLICABLE

PART 3 - EXECUTION

3.01 INSTALLATION:

- A. The Contractor shall provide temporary plugs or provide other suitable means for maintaining the new drain free of drainage flow until such time as it can be inspected and tested for leakage.
- B. Connections to the new drain shall be made when required by the Engineer and only after the new pipeline has been inspected and has successfully passed the leakage test.
- C. The Contractor shall modify each existing structure for installation of the necessary piping, but in so doing shall confine the cutting to the smallest amount possible consistent with the work to be done.
- D. All new piping connected to existing structures shall be encased in concrete in a manner satisfactory to the Engineer.
- E. All work shall be done with the proper tools and by careful workmen competent to do work.
- F. The Contractor shall cut, reshape and fill the existing manhole tables and plug existing outlets as indicated on the drawings and as required by the Engineer, to accommodate the new connections. Reshaped manhole invert channels shall be smoothly shaped to permit the flow of drainage.

END OF SECTION

SECTION 33 39 13

PRECAST MANHOLES

PART 1 - GENERAL

1.01 WORK INCLUDED:

This Section covers all precast manholes and catch basins complete, including, but not limited to, bases, walls, cones, mortar, inverts, frames and covers.

1.02 RELATED WORK:

- A. Section 31 00 00, EARTHWORK

1.03 SYSTEM DESCRIPTION:

- A. Precast sections shall conform in shape, size, dimensions, materials, and other respects to the details indicated on the drawings or as required by the Engineer.
- B. All manholes and catch basins shall have concrete bases. Concrete bases shall be precast unless otherwise specified. Invert channels shall be formed of brick and mortar upon the base.
- C. Riser and cone sections shall be precast concrete.

1.04 REFERENCES:

- A. The following standards form a part of this specification as referenced:

American Society for Testing and Materials (ASTM)

ASTM A48	Gray Iron Castings
ASTM C32	Sewer and Manhole Brick
ASTM C144	Aggregate for Masonry Mortar
ASTM C207	Hydrated Lime for Masonry Purposes
ASTM C478	Precast Reinforced Concrete Manhole Sections
ASTM C923	Specification for Resilient Connectors Between Reinforced Concrete Manhole Structures and Pipes

ASTM C1244 Standard Test Method for Concrete Sewer Manholes by the Negative Air Pressure (Vacuum) Test.

American Association of State Highway and Transportation Officials (AASHTO)

AASHTO M198 Joints for Circular Concrete Sewer and Culvert Pipe Using Flexible Watertight Gaskets

Occupational Safety and Health Administration

OSHA 29 CFR 1910.27 Fall Prevention Protection

1.05 SUBMITTALS: IN ACCORDANCE WITH REQUIREMENTS OF SECTION 01 33 23 SUBMITTALS, SUBMIT THE FOLLOWING:

- A. Manufacturer's literature of the materials of this section.
- B. Test reports as required by the Engineer.

PART 2 - PRODUCTS

2.01 PRECAST CONCRETE SECTIONS:

A. All precast concrete sections shall conform to ASTM C478 with the following exceptions and additional requirements:

- 1. The wall thickness of precast sections shall be as designated on the drawings, meeting the following minimum requirements:

<u>Section Diameter (Inches)</u>	<u>Minimum Wall Thickness (Inches)</u>
48	5
60	6
72	7
84	8

- 2. Type II cement shall be used except as otherwise approved.
- 3. Sections shall be steam cured and shall not be shipped until at least five days after having been cast.
- 4. Minimum compressive strength of concrete shall be 4000 psi at 28 days.
- 5. No more than two lift holes may be cast or drilled in each section.
- 6. The date of manufacture and the name or trademark of the manufacturer shall be clearly marked on the inside of each precast section.

7. Acceptance of the sections will be on the basis of material tests and inspection of the completed product.
 8. Circumferential steel reinforcement in walls and bases shall be a minimum of 0.12 sq. in./lin. ft. for 4-foot diameter sections and 0.15 sq. in./lin. ft. for 5- and 6-foot diameter sections. Reinforcing shall extend into tongue and groove.
- B. Conical reducing sections shall have a wall thickness not less than 5-inches at the bottom and wall thickness of 8-inches at the top. Conical sections shall taper from a minimum of 48-inches diameter to 24 or 30-inches diameter at the top, as shown on the drawings.
 - C. Except where insufficient depth of cover dictates the use of a shorter base, bases shall be a minimum of 4 feet in height.
 - D. Slab top sections and flat riser sections (Grade Rings) shall conform to the contract drawings, with particular attention focused upon the reinforcing steel and be designed to meet or exceed an HS-20 Loading requirement.
 - E. The tops of the bases shall be suitably shaped by means of accurate ring forms to receive the riser sections.
 - F. Precast sections shall be manufactured to contain wall openings of the minimum size to receive the ends of the pipes, such openings being accurately set to conform with line and grade of the sewer or drain. Subsequent cutting or tampering in the field, for the purpose of creating new openings or altering existing openings, will not be permitted except as required by the Engineer.
 - G. The exterior surfaces of all precast manhole bases, walls, and cones shall be given a minimum of one shop coat of bituminous dampproofing.
 - H. The Engineer reserves the right to reject any unsatisfactory precast section and the rejected unit shall be tagged and removed from the job site immediately.
 - I. The Engineer may also require the testing of concrete sections as outlined under Physical Requirements in ASTM C478 with the Contractor bearing all testing costs.

2.02 FRAMES, GRATES, COVERS AND STEPS:

- A. Castings shall be of good quality, strong, tough, even-grained cast iron, smooth, free from scale, lumps, blisters, sandholes, and defects of every nature which would render them unfit for the service for which they are intended. Contact surfaces of covers and frame seats shall be machined to prevent rocking of covers.
- B. All castings shall be thoroughly cleaned and may be subject to a careful hammer inspection at the Engineer's discretion.

- C. Castings shall be ASTM A48 Class 30B or better.
- D. The surface of the manhole covers shall have a diamond pattern with the cast words "WATER," "DRAIN" or "SEWER," whichever is appropriate.
- E. Manhole frames with 26-inch covers for 24-inch openings shall be 475 pounds minimum by EJ No. 2110 (formerly LK110A); Neenah Foundry Co. R1720; Quality Water Products, Style 40; or approved equal.
- F. Watertight type manhole frames with 26-inch diameter covers (bolted and gasketed) shall be EJ No. 1268; Mechanics Iron Foundry Type A2073; Quality Water Products, Style 40WT; or approved equal.

2.03 MANHOLE FALL PREVENTION SYSTEMS:

- A. Where manholes exceed 20 vertical feet from the proposed rim elevation to the invert, manholes shall be provided with a fall prevention system. Fall prevention systems shall be in accordance with OSHA requirement 29 CFR 1910.27 and as described herein and as indicated on the contract drawings.
- B. Carrier rail assembly shall be 1-5/16-inch O.D. by 1-inch ID Type 6061-T6 aluminum notched; 0.875-inches by 0.875-inches by 5/32-inch at 6-inch centers; tapped 3/8-inch at 9-inch centers opposite notches.
- C. Manhole rung clamp assembly shall be constructed from 6061-T6 aluminum 11-inches long by 1.25-inches wide with 2 slots 7/16-inch by 1.25-inches at 9-inch centers and serrated on one side.
- D. Safety locking mechanism shall be cast of manganese bronze with stainless steel springs, and drop forged links and snap-locking pawl shall be minimum tensile strength of 110,000 psi. Roller bearing shall be killian type. Stainless steel springs shall comply with Military Specification QQ-W-423B.
- E. Safety harness shall be adjustable to fit waists 30-inch to 48-inch. Belt shall be nylon web equipped with 3 stainless steel 'D' rings.
- F. Fall prevention systems shall be manufactured by DBI/SALA, Safe Approach or approved equal.

PART 3 - EXECUTION

3.01 INSTALLATION:

A. PRECAST SECTIONS:

1. Precast bases shall be supported on a compacted level foundation of crushed stone,

as specified in Section 31 00 00 EARTHWORK, at least 6-inches thick, but shall vary to the depth necessary to reach sound undisturbed earth.

2. Precast reinforced concrete sections shall be set vertical and with sections in true alignment.
3. Butyl rubber joint sealant shall be installed between each concrete section. Catch basin sections do not require joint sealant if so indicated on the drawings.
4. All holes in sections used for handling the sections shall be thoroughly plugged with mortar. Mortar shall be one part cement to 1-1/2 parts sand, mixed slightly damp to the touch (just short of "balling"), hammered into the holes until it is dense and an excess of paste appears on the surface, and then finished smooth and flush with the adjoining surfaces.

B. CASTINGS:

1. Cast iron frames, grates and covers shall be as specified. The frames and covers shall be set by the Contractor to conform accurately to the grade of the finished pavement, existing ground surface, or as indicated on the drawings. Frames shall be adjusted to meet the street surface.
2. Cast iron manhole frames and covers not located in paved areas shall be set 6-inches above finished grade, at a height as required by the Engineer, or as indicated on the drawings. The top of the cone shall be built up with a minimum of 1 course and a maximum of 5 courses of brick and mortar used as headers for adjustment to final grade.
3. Frames shall be set concentric with the top of the concrete section and in a full bed of mortar so that the space between the top of the concrete section or brick headers and the bottom flange of the frame shall be completely filled and made watertight. A thick ring of mortar extending to the outer edge of the concrete shall be placed all around the bottom flange. The mortar shall be smoothly finished to be flush with the top of the flange and have a slight slope to shed water away from the frame.
4. Covers and/or grates shall be left in place in the frames, for safety reasons, except while work is being performed.

C. ACCESSORIES:

1. Accessories shall be installed in accordance with manufacturer's instructions.
2. Stubs shall be set accurately to the dimensions indicated on the drawings. Stubs shall be sealed with suitable watertight plugs.

D. MANHOLE FALL PREVENTION SYSTEM:

Carrier rail shall extend from the manhole invert shelf to within 18-inches of finish grade. The rail and manhole rung clamp assembly shall be rigidly connected utilizing 3/8-inch stainless steel bolts. Assembly shall be clamped to manhole steps at 2-foot centers or as recommended by the manufacturer.

3.02 LEAKAGE TESTS:

A. Leakage tests shall be made by the Contractor and observed by the Engineer on each manhole. The test shall be by vacuum or by water exfiltration as described below:

B. VACUUM TEST:

1. The vacuum test shall be conducted in accordance with ASTM C1244. Test results will be judged by the length of time it takes for the applied vacuum to drop from 10 inches of mercury to 9 inches. If the time is less than that listed in Table 1 of ASTM C1244, the manhole will have failed the test. Test times from Table 1 are excerpted below.

TABLE 1

Minimum Test Times for Various Manhole Diameters

Depth (Feet)	Diameter (Inches)		
	48	60	72
	<u>Times (Seconds)</u>		
0-12	30	39	49
12-16	40	52	67
16-20	50	65	81
20-24	59	78	97
26-30	74	98	121

2. If the manhole fails the initial test, the Contractor shall locate the leaks and make proper repairs. Leaks may be filled with a wet slurry of accepted quick setting material. If the manhole should again fail the vacuum test, additional repairs shall be made, and the manhole water tested as specified below.

C. WATER EXFILTRATION TEST:

1. After the manhole has been assembled in place, all lifting holes shall be filled and pointed with an approved non-shrinking mortar. All pipes and other openings into the manhole shall be suitably plugged and the plugs braced to prevent blow out. The test shall be made prior to placing the shelf and invert. If the groundwater table has been allowed to rise above the bottom of the manhole, it shall be lowered for the duration of the test.

2. The manhole shall be filled with water to the top of the cone section. If the

excavation has not been backfilled and observation indicates no visible leakage, that is, no water visibly moving down the surface of the manhole, the manhole may be considered to be satisfactorily water-tight. If the test, as described above, is unsatisfactory as determined by the Engineer or if the manhole excavation has been backfilled, the test shall be continued. A period of time may be permitted if the Contractor so wishes, to allow for absorption by the manhole. At the end of this period, the manhole shall be refilled to the top of the cone, if necessary, and a measuring time of at least 8 hours begun. At the end of the test period, the manhole shall be refilled to the top of the cone, measuring the volume of water added. This amount shall be extrapolated to a 24-hour loss rate and the leakage determined on the basis of depth. The leakage for each manhole shall not exceed one gallon per vertical foot for a 24-hour period. If the manhole fails this requirement, but the leakage does not exceed 3 gallons per vertical foot per day, repairs by approved methods may be made as required by the Engineer to bring the leakage within the allowable rate of one gallon per foot per day. Leakage due to a defective section or joint or exceeding the 3 gallon per vertical foot per day, shall be cause for rejection of the manhole. It shall be the Contractor's responsibility to uncover the rejected manhole as necessary and to disassemble, reconstruct or replace it as required by the Engineer. The manhole shall then be retested and, if satisfactory, interior joints shall be filled and pointed.

3. No adjustment in the leakage allowance will be made for unknown causes such as leaking plugs, absorption, etc. It shall be assumed that all loss of water during the test is a result of leaks through joints or through the concrete. Furthermore, the Contractor shall take any steps necessary to assure the Engineer that the water table is below the bottom of the manhole throughout the test.
4. If the groundwater table is above the highest joint in the manhole, and there is no leakage into the manhole, as determined by the Engineer, such a test can serve to evaluate water-tightness of the manhole. However, if the Engineer is not satisfied with the results, the Contractor shall lower the water table and carry out the test as described hereinbefore.

3.03 CLEANING:

All new manholes shall be thoroughly cleaned of all silt, debris and foreign matter of any kind, prior to final inspection.

END OF SECTION

SECTION 33 41 13.22

CORRUGATED POLYETHYLENE [HDPE] DRAINAGE PIPE

PART 1 – GENERAL

1.01 WORK INCLUDED:

- A. This section includes furnishing all materials, labor and equipment and installing corrugated polyethylene [HDPE] drainage pipe and fittings as shown on the drawings and as specified herein.

1.02 RELATED WORK:

- A. Section 31 00 00, EARTHWORK
- B. Section 31 50 00, SUPPORT OF EXCAVATION

1.03 REFERENCES:

- A. The following standards form a part of this specification, as referenced:

American Society for Testing and Materials (ASTM)

ASTM D2321	Standard for Underground Installation of Thermoplastic Pipe for Sewers and Other Gravity Flow Applications
ASTM F405	Standard Specification for Corrugated Polyethylene Pipe and Fittings
ASTM F667	Standard Specification for Large Diameter Corrugated Polyethylene Pipe and fittings

American Association Of State Highway and Transportation Officials

AASHTO M294	Standard Specification for Corrugated Polyethylene Pipe
AASHTO MP6	Standard Specification for Corrugated Polyethylene Pipe 42” and 48” Diameter

1.04 SUBMITTALS: IN ACCORDANCE WITH REQUIREMENTS OF GENERAL SPECIFICATIONS, SUBMIT THE FOLLOWING:

- A. Six sets of manufacturer’s literature on the materials of this Section shall be submitted to the Engineer for review.
- B. Manufacturer’s certification that the product was manufactured, tested, and supplied in accordance with this specification shall be furnished.

1.05 DELIVERY, STORAGE AND HANDLING:

- A. Pipe shall be packaged to withstand shipment without damage and handled carefully on the jobsite. Pipe shall be stored so that it is not exposed to sunlight.

PART 2 – PRODUCTS:

2.01 MATERIALS:

- A. This Section applies to corrugated polyethylene pipe with an integrally formed smooth interior.
- B. The nominal size for the pipe and fittings is based on the nominal inside diameter of the pipe.
- C. The pipe and fittings shall be free of foreign inclusions and visible defects. Fittings may be either molded or fabricated. Fittings supplied by manufacturers other than the supplier of the pipe shall not be permitted without the approval of the Engineer. The ends of the pipe shall be cut squarely and cleanly so as not to adversely affect joining.

2.02 MANUFACTURERS:

- A. Pipe and fittings shall be manufactured by Ipex, Inc.; Plexco, Division of Chevron Chemical Co.; J-M Pipe Co.; Advanced Drainage Systems, Inc. (ADS) or approved equal.

PART 3 – EXECUTION

3.01 INSTALLATION:

- A. Pipe interiors, fitting interiors, and joint surfaces shall be thoroughly cleaned before installation. Pipes and fittings shall be maintained clean.
- B. Pipes shall be installed in the locations and to the required lines and grades shown on the drawings and provided in these Specifications, using an approved method of control.
- C. Excavations shall be maintained free of water during the progress of the Work. No pipes shall be laid in water, nor shall there be any joints made up in water.
- D. If any defective pipe is discovered after being placed, removal and replacement with sound pipe will be required at no additional cost to the Owner.

END OF SECTION

APPENDIX A

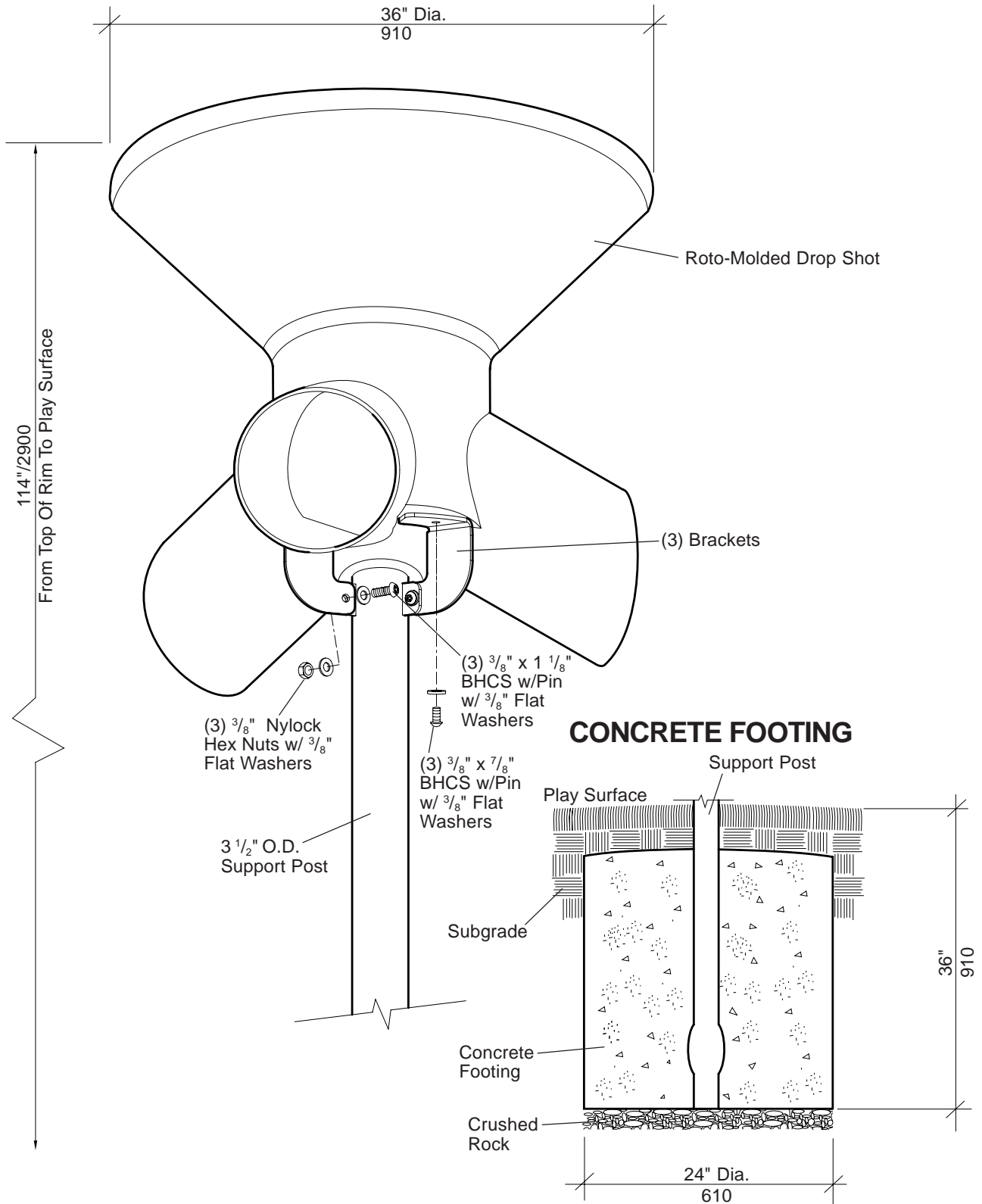

Parts List

Part#	Description	Qty
127161-00	Drop Shot, Specify Color	1
144219-00	Support Post, Specify Color	1
144244-00	Bracket, Specify Color	3
160507-00	Drop Shot Hardware Package	1
100198-00	$\frac{3}{8}$ " x $1\frac{1}{8}$ " BHCS w/Pin, SST	3
100362-00	$\frac{3}{8}$ " Flat Washer, SST	9
136931-00	$\frac{3}{8}$ " Nylock Hex Nut, SST	3
100196-00	$\frac{3}{8}$ " x $\frac{7}{8}$ " BHCS w/Pin, SST	3

Specifications

Drop Shot: Rotationally molded from U.V. stabilized linear low density polyethylene, color specified. Drop shot measures 3' in diameter.

Support Post: Fabricated from 3.500" O.D. RS-20 (.120" - .130") galvanized steel tubing. Finish: Powdercoat, color specified.

Bracket: Fabricated from $\frac{1}{4}$ " HRPO flat steel. Finish: Powdercoat, color specified.

Fasteners: Primary fasteners shall be socketed and pinned tamperproof in design, stainless steel (SST) per ASTM F 879 unless otherwise indicated (see specific product installation/specifications).

Installation Time: Approx. 2 $\frac{1}{2}$ man hours

Concrete Req.: Approx. 8.4 cu. ft.

Area Req.: 25' (7.62 m) diameter

Weight: 95 lbs.

Installation Instructions

- 1) Dig footing to width and depth shown.
- 2) Insert support pipe into drop shot.
- 3) Attach brackets to support pipe tabs using $\frac{3}{8}$ " x $1\frac{1}{8}$ " BHCS w/pin with $\frac{3}{8}$ " flat washers and $\frac{3}{8}$ " nylock hex nuts with $\frac{3}{8}$ " flat washers.
- 4) Attach drop shot to brackets using $\frac{3}{8}$ " x $\frac{7}{8}$ " BHCS w/pin with $\frac{3}{8}$ " flat washers.
- 5) Place assembly in footing hole and temporarily brace in plumb position.
- 6) Pour concrete footing and let cure for a minimum of 72 hours before removing braces.
- 7) Install play surface.

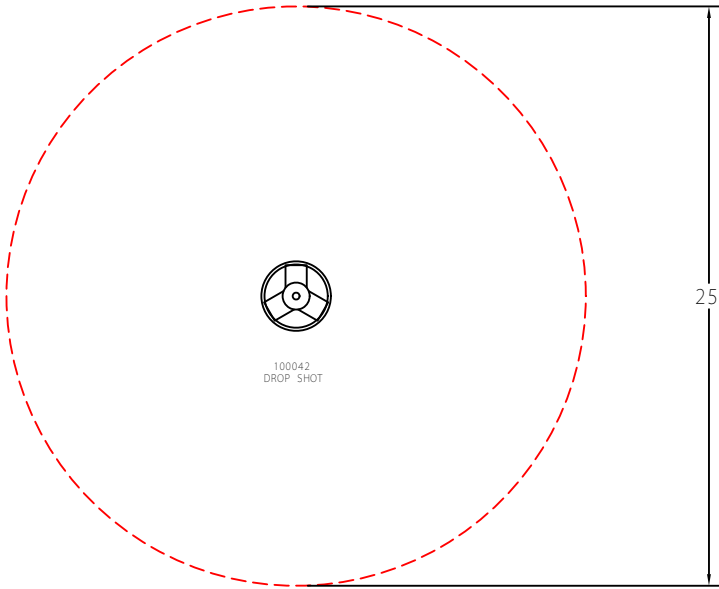

100042
DROP SHOT

25'

TOTAL ELEVATED PLAY COMPONENTS	0	REQUIRED	0
TOTAL ELEVATED COMPONENTS ACCESSIBLE BY RAMP	0	REQUIRED	0
TOTAL ELEVATED COMPONENTS ACCESSIBLE BY TRANSFER	0	REQUIRED	0
TOTAL ACCESSIBLE GROUND LEVEL COMPONENTS SHOWN	0	REQUIRED	0
TOTAL DIFFERENT TYPES OF GROUND LEVEL COMPONENTS	0	REQUIRED	0



DESIGN # 963

LANDSCAPE STRUCTURES
INC.

SYSTEM TYPE:
NO - STRUCTURE
DRAWING #:



The play components identified on this plan are IPEMA certified. The use and location of these components conform to the requirements of ASTM F-1487.

THIS PLAY AREA & EQUIPMENT IS DESIGNED FOR AGES 2-12 YEARS.

IT IS THE MANUFACTURER'S OPINION THAT THIS PLAY AREA DOES CONFORM TO THE A.S.A. ACCESSIBILITY GUIDELINES (AGAG) ASSUMING AN ACCESSIBLE PROTECTIVE SURFACING IS PROVIDED AS INDICATED, OR WITHIN THE INTENT USE ONLY.

THIS CONCEPTUAL PLAN HAS BASED ON INFORMATION AVAILABLE TO US. PRIOR TO CONSTRUCTION, DETAIL SITE INFORMATION INCLUDING: SITE DIMENSIONS, TOPOGRAPHY, EXISTING UTILITIES, SOIL CONDITIONS, AND DRAINAGE SOLUTIONS SHOULD BE OBTAINED, EVALUATED, & UTILIZED IN THE FINAL DESIGN. PLEASE VERIFY ALL DIMENSIONS OF PLAY AREA, SOIL, ORIENTATION, AND LOCATION OF ALL EXISTING UTILITIES, EQUIPMENT, AND SITES SHOULD NOT FACE THE HOT AFTERNOON SUN.

CHOOSE A PROTECTIVE SURFACING MATERIAL THAT HAS A MINIMUM STATIC COEFFICIENT OF FRICTION OF 0.5. THE SURFACING SHOULD BE AT LEAST THE HEIGHT OF THE HIGHEST ACCESSIBLE PARTIAL HEIGHT OF THE EQUIPMENT. REFER TO CONSUMER PRODUCT SAFETY COMMISSION (CPSC) GUIDELINES, SECTION 10, SURFACING.

DESIGNED BY:
LSJ
COPYRIGHT:
LANDSCAPE STRUCTURES, INC.



Cloud 9 – Product Specification



HodgePodge – A variety of study and durable sport and play elements

HodgePodge is a clever and versatile combination of play equipment and climbing structures that can be used anywhere and for numerous activities.

Climbing trees, a Wasp's nest, Volleyball nets for sporting activities, cable rides for fun and excitement.

At a glance.

Product Family:	HodgePodge	Number of Foundations:	2 pc.
Item Number:	97.100.025	Concrete Volume C20/C25:	0.7 m³ (24.7 ft³)
Children's Age:	3+	Number of skilled installers required:	2
Fall Height (DIN EN 1176):	1.80 m (5'-11")	Installation Time without foundation:	2 hours
Length x Width x Height:	3.2 m x 1.2 m x 2.0 m (10'-5" x 4'-0" x 6'-8")	Dimensions of largest part:	Ø 0.1 x 3.1 m (0'-4" x 10'-2")
Protective Surfacing Area (DIN EN 1176):	6.2 m x 6.4 m	Weight of heaviest part:	70 kg (154.3 lbs)
Protective Surfacing Area (ASTM 1487):	6.8 m x 8.1 m (22'-4" x 26'-7")	Shipping Volume:	1.8 m³ (63.6 ft³)
Minimum space required DIN EN 1176:	26.6 m²	Spare part guarantee:	Lifelong
Minimum space required ASTM 1487:	31.0 m² (333.7 sf)	Certificate according to EN 1176:	No.: Z2.16.01.10256.259 TÜV Product Service

Berliner
 Berliner Seilfabrik
 Play Equipment Corporation
 96 Brookfield Oaks Drive, Suite 140
 Greenville, SC 29607

T + 1 864 627 1092
 F + 1 864 627 1178

www.berliner-playequipment.com
info@berliner-seilfabrik.com

Cloud 9 – Product Specification



Technical Data.

The following text can also be used for tenders.

Steel posts Jan:

Steel pipes \varnothing 133 mm (5 1/4") with rounded cast aluminum post top, minimum wall thickness 7.1mm (1/4"); anticorrosion treatment and color finish: sandblasting and zinc-/ epoxy-/ polyester-process.

Nodes:

Framework-aluminum ball connectors; \varnothing 250 mm (9-13/16"); anti-corrosion treatment and color finish: sandblasting and solvent-free zinc-/ epoxy-/ polyester-process; incorporating an ASTEM TT net tensioning system; securely closed with durable EPDM- caps

Seat:

Galvanized steel ring covered with shock-absorbing material and wrapped with fiber rope (\varnothing 20 mm); coil: 115 mm x 95 mm); tight-knit net made of Usacord rope (16 mm) is hung into the ring

Ropes:

U-Rope-round strand ropes with steel cores, \varnothing 16mm (5/8") – unless otherwise noted; with galvanized wires, external strands covered with non-abrasive UV-resistant Polyester-yarn.

t.



Berliner
Berliner Seilfabrik
Play Equipment Corporation
96 Brookfield Oaks Drive, Suite 140
Greenville, SC 29607

T + 1 864 627 1092
F + 1 864 627 1178

www.berliner-playequipment.com
info@berliner-seilfabrik.com

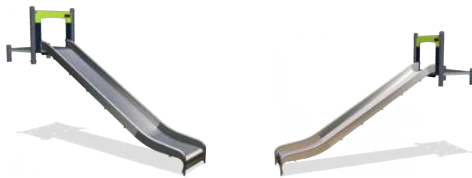

Embankment Slide - Wide



Elevated Activities: 0	Accessible Elevated Activities	Accessible Ground Level Activities	Accessible Ground Level Play Types
Present	0	1	1
Required	0	1	1

Sliding is a favourite occupation for children of all ages, adding that stomach tickling feeling of speed. The more the merrier, so the Wide Embankment Slide is an all-time favourite with its roomy bed taking children side-by-side to the ground at high speed. The width of the slide bed also allows for adults and care givers to go down the slide with children, who are cautious to go on their own or in need of assistance for other reasons. The play advantage of an embankment slide is the interaction that can be undertaken with friends when going down the very same hill that they are running or climbing up or down. Apart from being great fun, sliding also trains the child's focal tracking and sense of space.

Product Line	Traditional play
Category	Slides
Age from	5 - 12
Max. fall height (CM)	100
Total height (CM)	260
Safety Zone	27.8 m2



IN-GROU.



ASTM

SUR-FACE

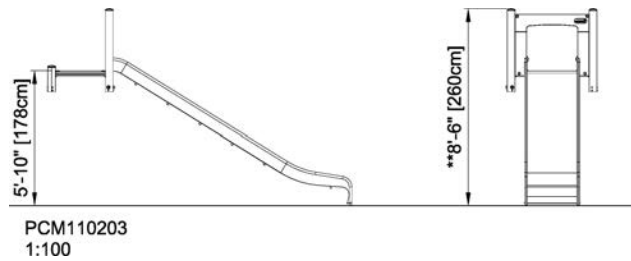
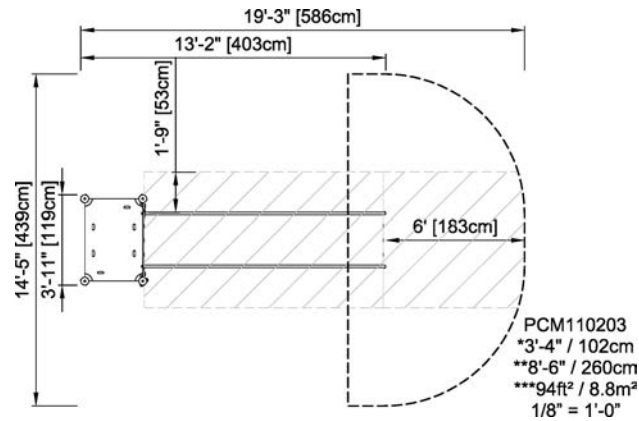

* = Highest designated play surface.
 ** = Total height of product.

Weight/heaviest parts	kg.	Installation (Manpower)	Persons
Concrete required	NaN m3	Installation (Hours)	Hours
Foundation amount/footing	NaN	Excavation	NaN m3



To verify product certification, visit www.ipema.org

Highest designated play surface and space required are according to ASTM F1487. Equipment must be installed over resilient surfacing appropriate to the safety guidelines in your area. Product development is an ongoing process. We reserve the right to make modifications on all our products. This product may not be mirrored, scaled or altered in any way. Safety zones must be retained for proper placement of equipment. If any changes are required, please contact your KOMPAN representative at 1.800.426.9788.

COROCORD EMBANKMENT SLIDES 0.5m width

CCC 710501-10300

H = 1.00m



CCC 710501-12300

H = 1.25m



CCC 710501-15300

H = 1.50m



CCC 710501-17300

H = 1.75m



CCC 710501-20300

H = 2.00m



CCC 710501-22300

H = 2.25m



CCC 710501-25300

H = 2.50m



CCC 710501-27300

H = 2.75m



CCC 710501-30300

H = 3.00m



COROCORD EMBANKMENT SLIDES 1.0m width

CCC 711001-10300

H = 1.00m



CCC 711001-12300

H = 1.25m

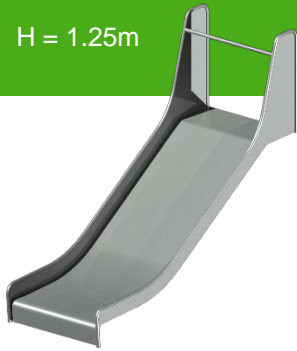

CCC 711001-15300

H = 1.50m

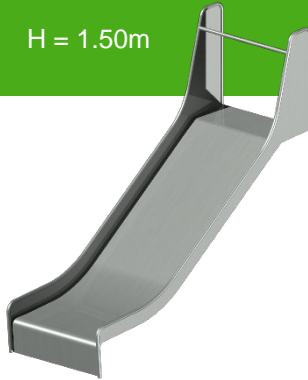

CCC 711001-17300

H = 1.75m



CCC 711001-20300

H = 2.00m

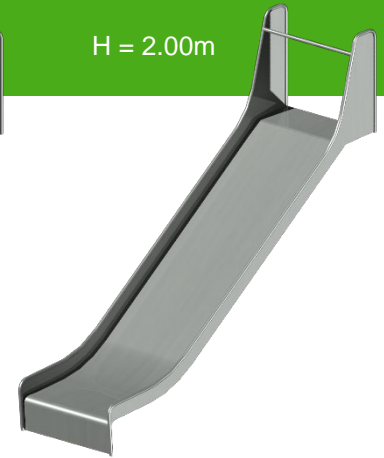

CCC 711001-22300

H = 2.25m



CCC 711001-25300

H = 2.50m



CCC 711001-27300

H = 2.75m



CCC 711001-30300

H = 3.00m



COROCORD EMBANKMENT SLIDES 1.5m width

CCC 711501-10300

H = 1.00m

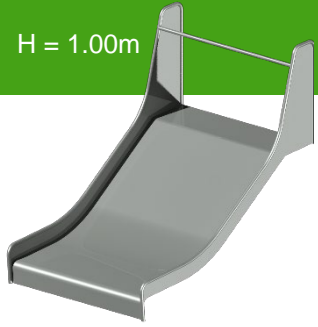

CCC 711501-12300

H = 1.25m

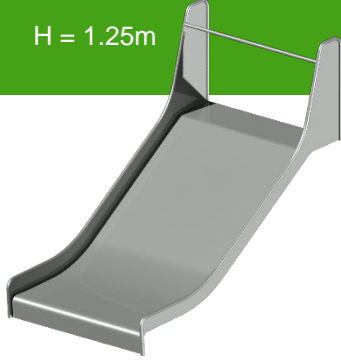

CCC 711501-15300

H = 1.50m

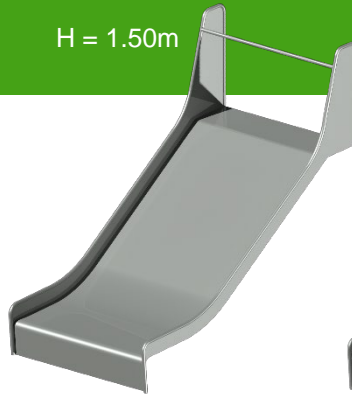

CCC 711501-17300

H = 1.75m

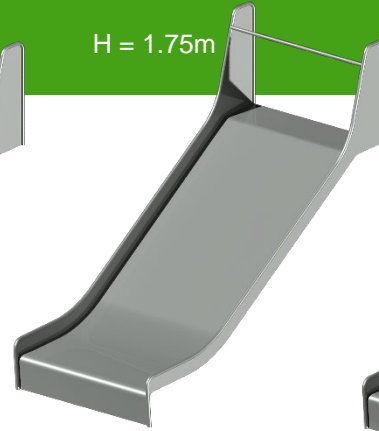

CCC 711501-20300

H = 2.00m

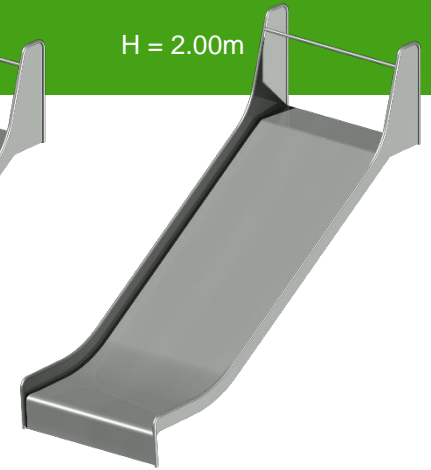

CCC 711501-22300

H = 2.25m



CCC 711501-25300

H = 2.50m



CCC 711501-27300

H = 2.75m



CCC 711501-30300

H = 3.00m



COROCORD EMBANKMENT SLIDES 2.0m width

CCC 712001-10300

H = 1.00m

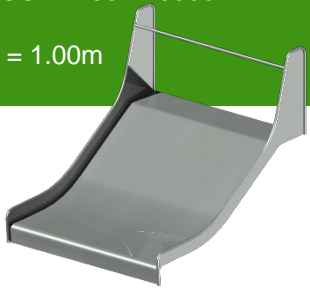

CCC 712001-12300

H = 1.25m



CCC 712001-15300

H = 1.50m

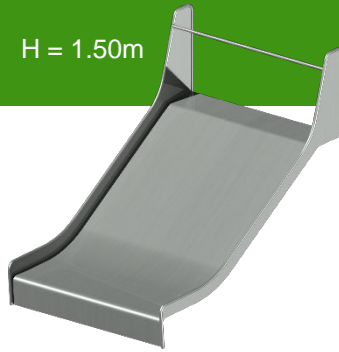

CCC 712001-17300

H = 1.75m

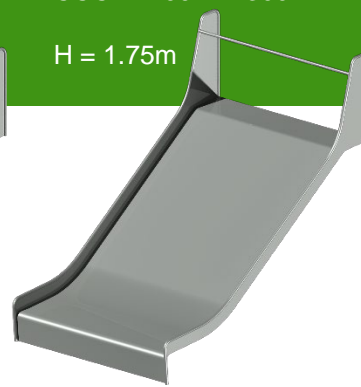

CCC 712001-20300

H = 2.00m

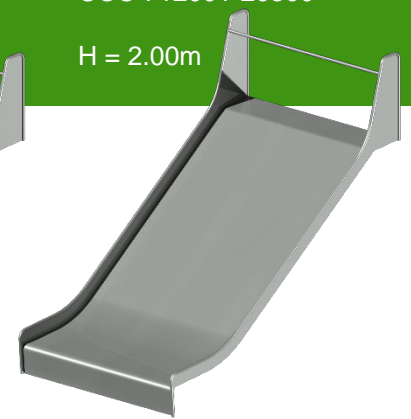

CCC 712001-22300

H = 2.25m



CCC 712001-25300

H = 2.50m



CCC 712001-27300

H = 2.75m

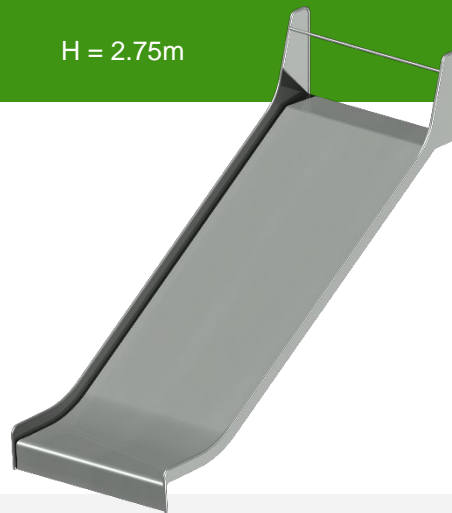

CCC 712001-30300

H = 3.00m



GXY960 SUPERNOVA

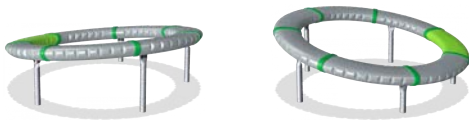
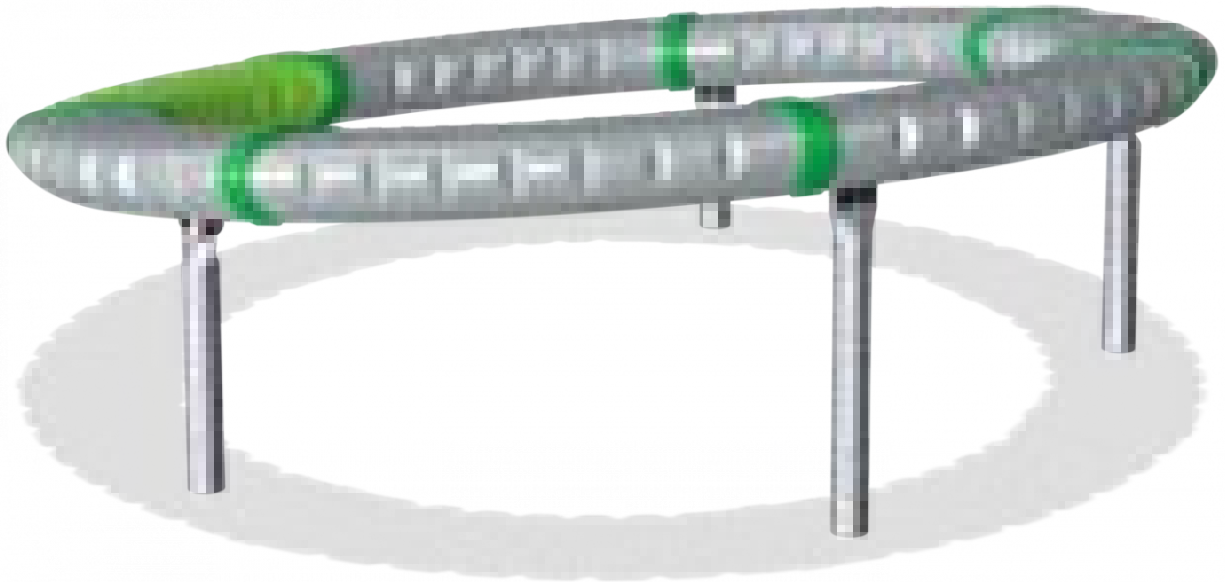

Use your strength and hold your balance! This seems to be the best way to describe the kind of play that takes place on the Supernova. A single child can engage in exploring its possibilities, but together with a whole group of children, this play item expresses its real potential. The large, slanting ring is set in motion by the children. Turning, spinning, balancing or just enjoying the ride are among the countless play options of the Supernova.

Product Line	Traditional play
Category	Supernova, carousels & spinners
Age from	5 - 12
Max. fall height (CM)	72
Total height (CM)	72
Safety Zone	45 m2



ASTM

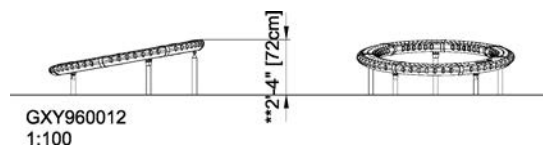
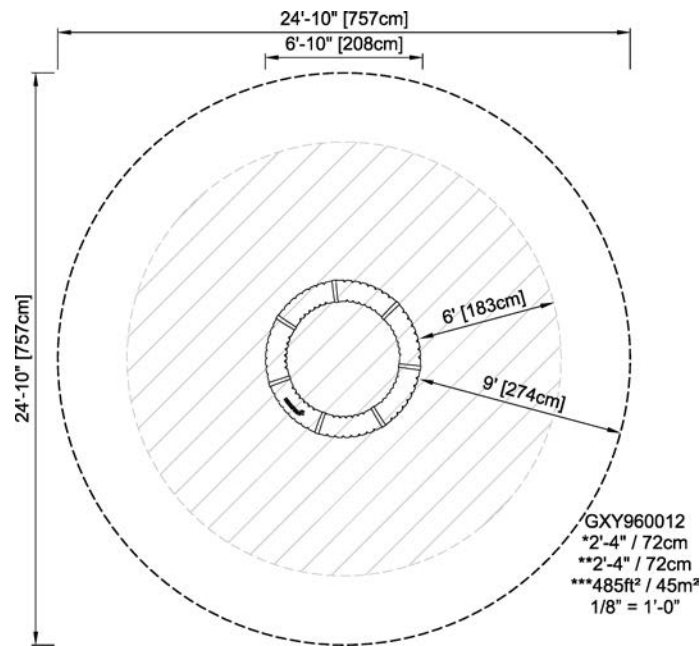

* = Highest designated play surface.
** = Total height of product.

Weight/heaviest parts	kg.	Installation (Manpower)	Persons
Concrete required	NaN m3	Installation (Hours)	Hours
Foundation amount/footing	NaN	Excavation	NaN m3



Highest designated play surface and space required are according to ASTM F1487. Equipment must be installed over resilient surfacing appropriate to the safety guidelines in your area. Product development is an ongoing process. We reserve the right to make modifications on all our products. This product may not be mirrored, scaled or altered in any way. Safety zones must be retained for proper placement of equipment. If any changes are required, please contact your KOMPAN representative at 1.800.426.9788.

To verify product certification,



THIS PLAY AREA & PLAY EQUIPMENT IS DESIGNED FOR AGES 5-12 YEARS UNLESS OTHERWISE NOTED ON PLAN.

IT IS THE MANUFACTURERS OPINION THAT THIS PLAY AREA DOES CONFORM TO THE ADA ACCESSIBILITY STANDARDS, ASSUMING AN ACCESSIBLE PROTECTIVE SURFACING IS PROVIDED, AS INDICATED, OR WITHIN THE ENTIRE USE ZONE.

THIS CONCEPTUAL PLAN WAS BASED ON INFORMATION AVAILABLE TO US, PRIOR TO CONSTRUCTION. DETAILED SITE INFORMATION INCLUDING SITE DIMENSIONS, TOPOGRAPHY, EXISTING UTILITIES, SOIL CONDITIONS, AND DRAINAGE SOLUTIONS SHOULD BE OBTAINED, EVALUATED, & UTILIZED IN THE FINAL DESIGN. PLEASE VERIFY ALL DIMENSIONS OF PLAY AREA, SITE, ORIENTATION, AND LOCATION OF UTILITIES, STRUCTURES, AND SITE FINISHINGS PRIOR TO GRADING. SLIDES SHOULD NOT FACE THE HOT AFTERNOON SUN.

CHOOSE A PROTECTIVE SURFACING MATERIAL THAT HAS A CRITICAL HEIGHT VALUE TO MEET THE MAXIMUM FALL HEIGHT FOR THE EQUIPMENT (REF. MANUFACTURERS SPECIFICATIONS). PROVIDE A PROTECTIVE SURFACING MATERIAL FROM ALL SURROUNDING EQUIPMENT FOR PUBLIC USE. SECTION & CURRENT REVISIONS, THE SURFACING MUST BE WELL DRAINED. IF THE SOIL DOES NOT DRAIN NATURALLY IT MUST BE TILED OR SLOPED 1/8" TO 1/4" PER FOOT TO A STORM SEWER OR A "FRENCH DRAIN".

IT IS THE MANUFACTURERS OPINION AND INTENT THAT THE LAYOUT OF THESE COMPONENTS CONFORM WITH THE U.S. CONSUMER PRODUCT SAFETY COMMISSION'S (CPSC) HANDBOOK FOR PUBLIC PLAYGROUND SAFETY™.

DESIGNED BY:
JRA

COPYRIGHT: 6.13.2019
LANDSCAPE STRUCTURES, INC.
601 7th STREET SOUTH - P.O. BOX 198
DELANO, MINNESOTA 55328
PH: 1-800-328-0335 FAX: 1-763-972-6091

Date	Previous Drawing #	Initials

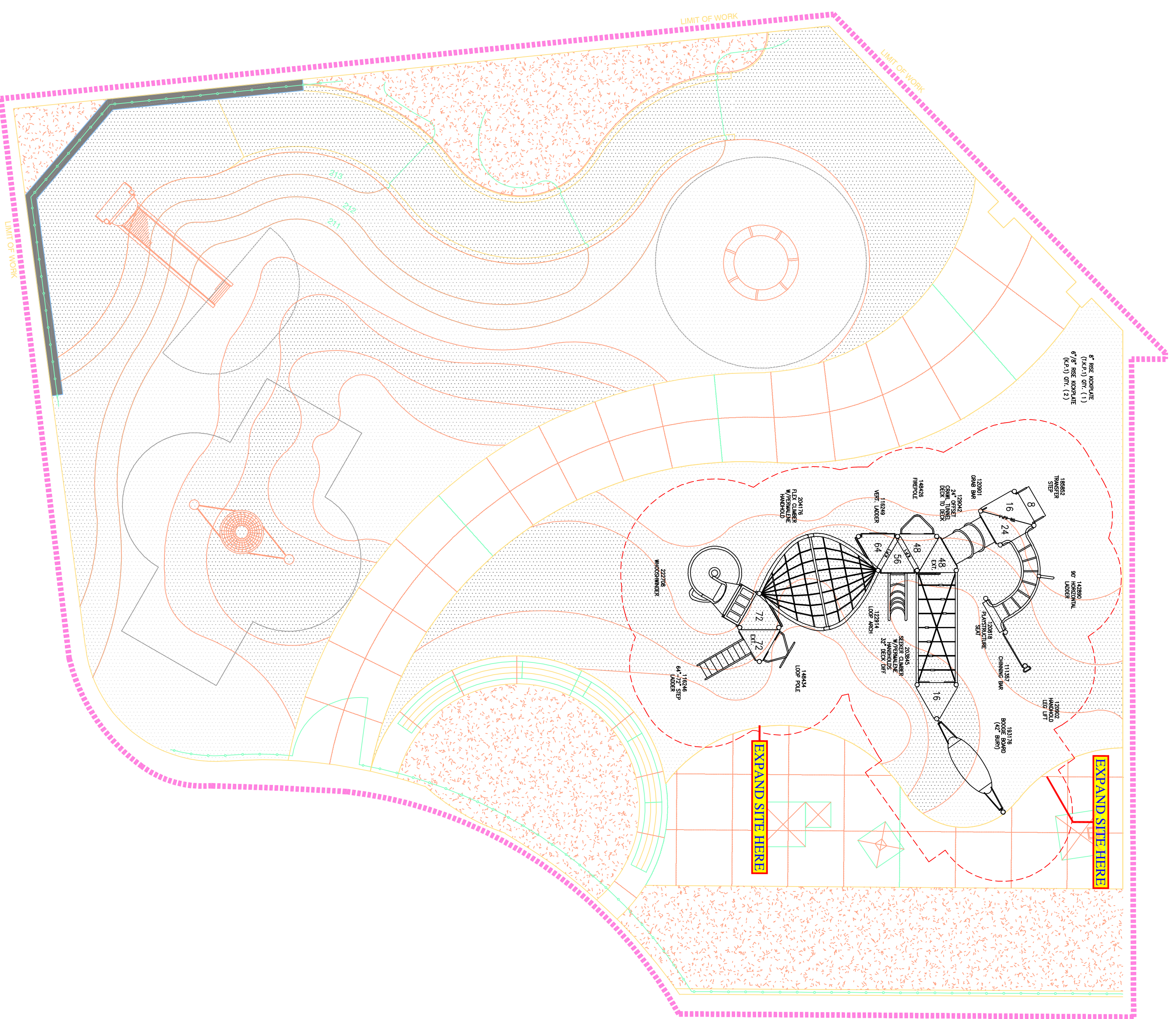

TOTAL ELEVATED PLAY COMPONENTS	10	0	REQUIRED	0
TOTAL ELEVATED COMPONENTS ACCESSIBLE BY RAMPS	0	0	REQUIRED	0
TOTAL ELEVATED COMPONENTS ACCESSIBLE BY TRANSFER	5	5	REQUIRED	5
TOTAL ACCESSIBLE GROUND LEVEL COMPONENTS SHOWN	3	3	REQUIRED	3
TOTAL DIFFERENT TYPES OF GROUND LEVEL COMPONENTS	3	3	REQUIRED	3

PEIRCE SCHOOL PLAYGROUND

ARLINGTON, MA

M.E. O'BRIEN &
SONS, INC.
MEGHAN O'BRIEN

SYSTEM TYPE:
PLAYBOOSTER

DRAWING #:
ME019410

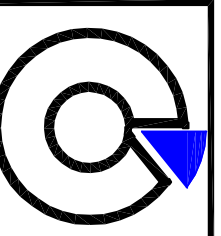

O'BRIEN & SONS
LANDSCAPE ARCHITECTS

93 West Street
PO Box 650
Medfield, MA 02052-0650
Phone 508-359-4200
Fax 508-359-2817



PlayCAD Quote

Date:06/13/2019
By:JRA

Rep Organization:
Contact Person: MEGHAN O'BRIEN

Quote No: MEO19410

Project Title: PEIRCE SCHOOL PLAYGROUND

Location: ARLINGTON, MA

PlayBooster® (5-12 years)						
PHASE-1 Direct Bury Mixed Material				UNIT		TOTAL
QTY	NO.	DESCRIPTION	WEIGHT (lb)		WEIGHT (lb)	
PlayBooster®						
Climbers W/Permalene Handholds						
1	204176A	Flex Climber w/Permalene Handhold 8" Deck Diff attached to 72"Dk				393.0
1	122914B	Loop Arch 56"Dk DB				80.0
1	148434B	Loop Pole Perm Handholds 72"Dk DB				62.0
1	203845A	Seeker Climber w/Permalene Handholds 32" Deck Diff Attached to 48"				224.0
1	116246D	Step Ladder 72"Dk DB				196.0
1	116249D	Vertical Ladder 64"Dk DB				57.0
Decks						
2	122197A	90* Triangular Tenderdeck	66.0			132.0
2	121948A	Kick Plate 8"Rise	13.0			26.0
1	185852A	Transfer Step w/2 Handloops DB				77.0
5	111231A	Triangular Tenderdeck	62.0			310.0
2	119646A	Tri-Deck Extension	51.0			102.0
1	121949A	Tri-Deck Kick Plate 8"Rise				13.0
Motion & More Fun						
1	193176A	Boogie Board DB Only				110.0
1	111357A	Chinning Bar Alum DB				41.0
1	120901A	Grab Bar				5.0
1	120902A	Handhold Leg Lift				4.0
1	120818A	Playstructure Seat				26.0
Overhead Events						
1	142890A	2"90* Horizontal Ladder DB Connected				114.0
Posts						
1	111404G	100"Alum Post DB				26.0
1	111404R	108"Steel Post DB 42" BURY				65.0
4	111404E	116"Alum Post DB	29.0			116.0
4	111404D	124"Alum Post DB	30.0			120.0
1	111404C	132"Alum Post DB				31.0
1	111404B	140"Alum Post DB				34.0
1	111404N	140"Steel Post DB				83.0
2	111404A	148"Alum Post DB	36.0			72.0

PlayCAD Quote

Date:06/13/2019
By:JRA

Rep Organization:
Contact Person: MEGHAN O'BRIEN

Quote No: MEO19410

Project Title: PEIRCE SCHOOL PLAYGROUND

Location: ARLINGTON, MA

PlayBooster® (5-12 years)						
PHASE-1 Direct Bury Mixed Material			UNIT		TOTAL	
QTY	NO.	DESCRIPTION	WEIGHT (lb)		WEIGHT (lb)	
1	111404M	148"Steel Post DB			88.0	
2	111404W	156"Steel Post DB	92.0		184.0	
1	111404H	92"Alum Post DB			23.0	
Slides						
1	148426A	Firepole Perm Handholds 48"Dk DB			56.0	
1	222708A	WhooshWinder Slide 72"Dk DB ¹			346.0	
Tunnels						
1	129042A	Offset Crawl Tunnel 24"Offset Deck To Deck			105.0	

SUMMARY	CONCRETE (cu-ft)	FOOTINGS (count)	LABOR (man-hours)	WEIGHT (lb)	
PlayBooster® (5-12 years) PHASE-1	60.6	34	62.3	3,321.0	
Total Safety Zone Area = 1219 sq. ft.					

ALL PHASES	PlayBooster®	CONCRETE (cu-ft)	FOOTINGS (count)	LABOR (man-hours)	WEIGHT (lb)
	PlayBooster®	60.6	34	62.3	3,321.0
	Total	60.6	34	62.3	3,321.0

- Square Footage calculation is approximate and for estimation purposes only. Landscape Structures shall not be held liable for any costs associated with surfacing by others.
- Estimated man-hours do not include hours for custom product installation or site preparation.
- ¹ This Quote has a total weight above 5,000 lbs or product(s) that require a freight quote. Freight tables cannot be used - Please contact LSI for a freight quote.
- This quote is valid for 60 days. Purchase orders submitted with an expired quote are subject to price changes. Custom freight quotes are valid for 30. Expired custom freight quotes are subject to changes.

MEO19410 PlayBooster® (5-12 years) Install

110070 is the Site Plan

Not an Install doc.

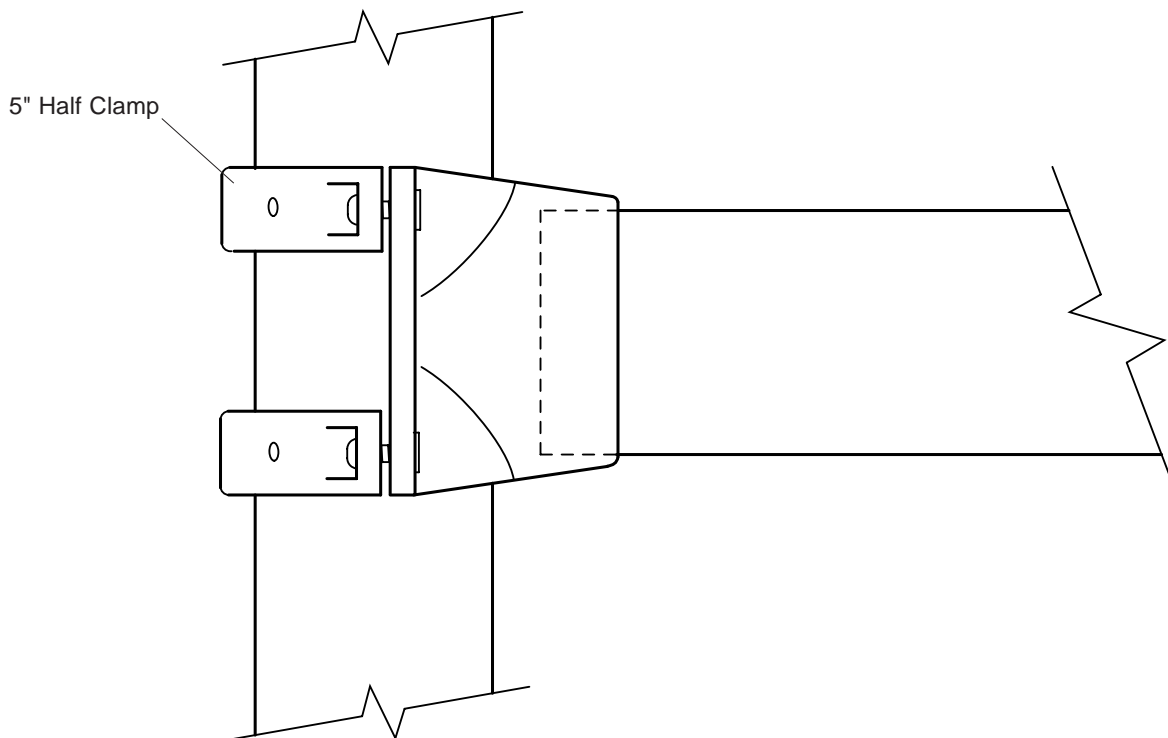
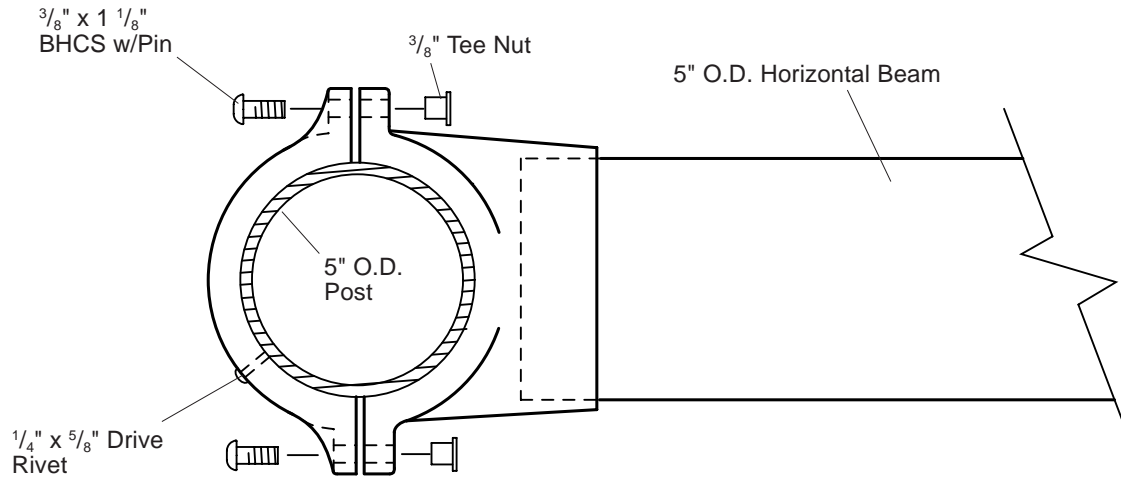

Parts List

Part#	Description	Qty
105327-01	5" Half Clamp, Specify Color	2
100198-00	$\frac{3}{8}$ " x 1 $\frac{1}{8}$ " BHCS w/Pin, SST	4
100351-00	$\frac{3}{8}$ " Tee Nut, SST	4
100610-00	$\frac{1}{4}$ " x $\frac{5}{8}$ " Drive Rivet, SST	2

Specifications

Tee/Beam: 356 alloy treated to T-6 hardness and welded to 5" aluminum beams or mechanically fastened to 5" steel beams. Finish: Powdercoat, color specified.

Half Clamps: Cast aluminum. Finish: Powdercoat, color specified.

Fasteners: Primary fasteners shall be socketed and pinned tamperproof in design, stainless steel (SST) per ASTM F 879 unless otherwise indicated (see specific product installation/specifications).

Installation Time: Approx. $\frac{1}{2}$ man hour

Weight: 2 lbs.

Installation Instructions

- 1) Locate and mark center of clamp location on 5" pipe.
- 2) With beam in position, fasten 5" half clamps to tee clamp using $\frac{3}{8}$ " x 1 $\frac{1}{8}$ " BHCS w/Pin and tee nuts as shown. Tighten cap screws evenly.
- 3) **IMPORTANT:** *Install drive rivets in half clamps by drilling holes in clamps and into 5" pipe using a $\frac{1}{4}$ " or "F"(only) drill bit. Insert rivet in hole, and hammer rivet pin in until it is flush with head.*

NOTE:
Surface mounting will not work in all applications. Consult Landscape Structures Inc. for your particular requirements.

- CONCRETE SLAB SPECS**
- Base under slab to be 4" - 6" of sand over a stable subgrade.
 - Depth of concrete slab to be 4" - 6" with a wire mesh support.
 - Minimum of 7 days curing time full cure after 30 days.
 - Surface of concrete to be trowled smooth and acid etched.
 - Concrete: 3000 PSI (Min)
30 Days 3500 PSI
 $\frac{3}{4}$ " Minus Crushed Rock

NOTE: Sufficient protective surfacing must cover hardware to satisfy fall height requirements.

NOTE:
Drill 3" deep hole using hammer drill and $\frac{1}{2}$ " masonry bit. Tap anchors into concrete and secure with $\frac{1}{2}$ " standard hex nuts and $\frac{1}{2}$ " flat washers.

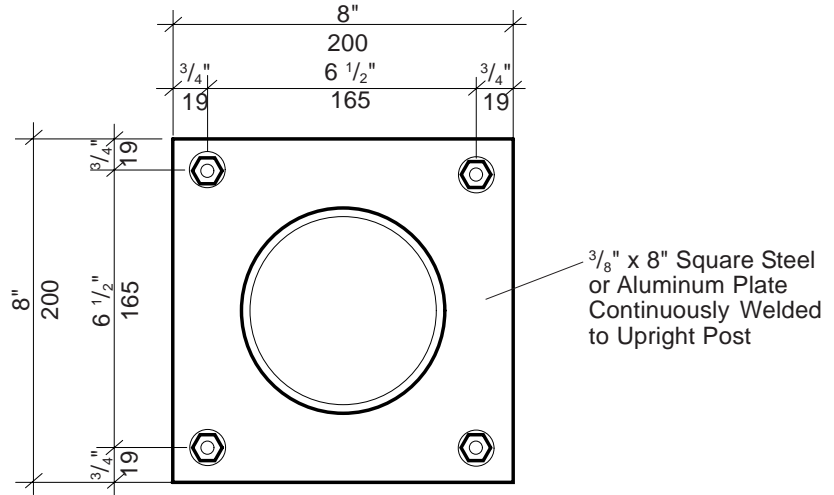

$\frac{3}{8}$ " x 8" Square Steel or Aluminum Plate Continuously Welded to Upright Post

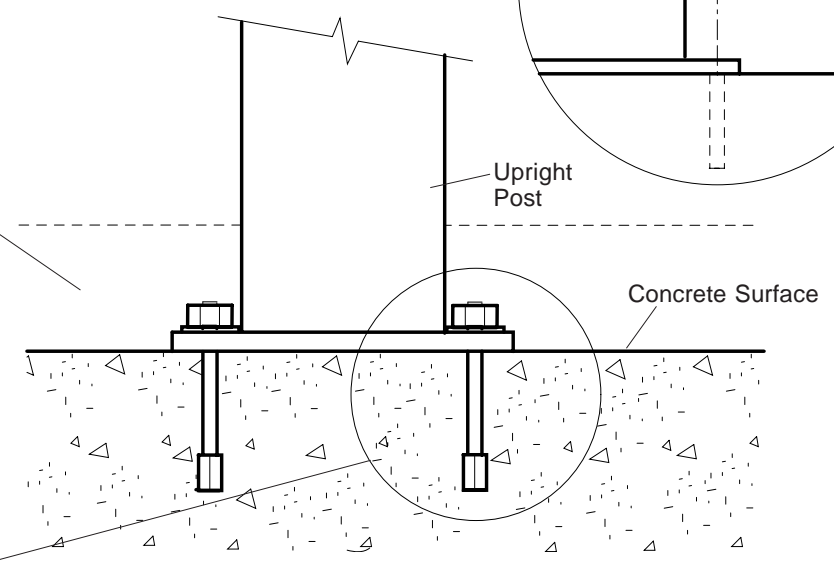
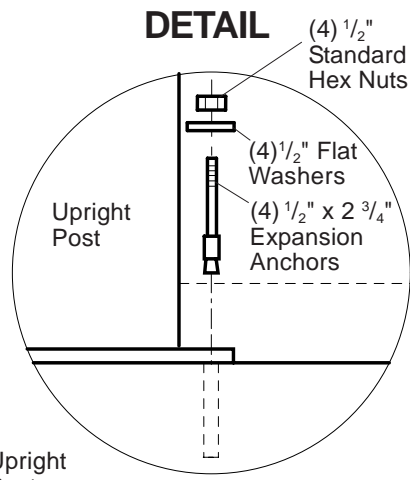

SAFETY NOTE
 Choose a protective surfacing material that has a Critical Height Value of at least the height of the Highest Accessible Part/Fall Height of the adjacent equipment. (Ref. ASTM F1487, SECTION 9.)

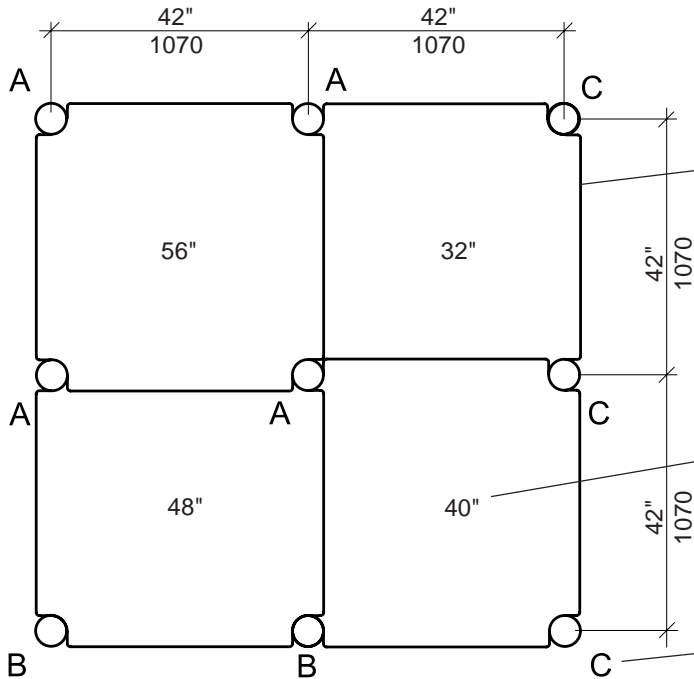

Enclosures or components are required on any decks higher than 28" as indicated on your plan drawing.

Dimension indicates center to center spacing of concrete footings.

Number indicates height of deck above finished grade.

Letter indicates post length as indicated on your plan drawing.

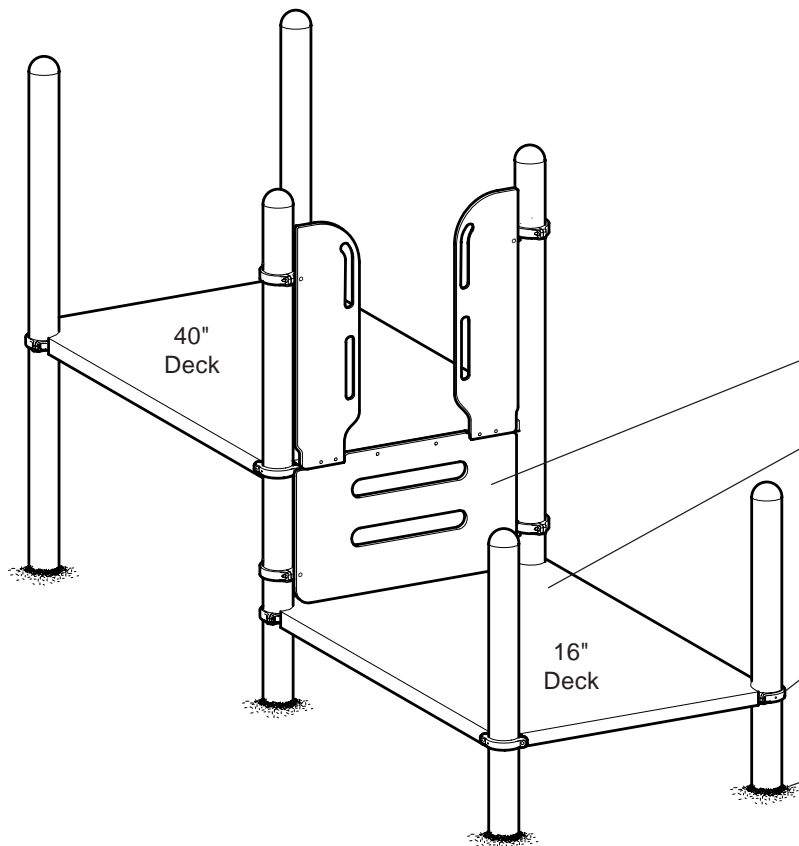

Enclosures/ Components - Refer to your plan drawing for locations and their respective spec sheets for installation.

Vertical Ladders - Refer to your plan drawing for locations and the Vertical Ladder spec sheet for installation.

Decks - Refer to your plan drawing for heights and orientation. Refer to the appropriate deck spec sheet for installation.

Deck Hanger Clamp Assembly - Refer to the appropriate Deck Assembly spec sheet for installation.

Concrete Footings - Refer to the Typical Concrete Footing spec sheet for installation.

Kick Plates - Refer to your plan drawing for locations and the Kick Plate spec sheet for installation.

PlayBooster General Post/Tenderdeck Information

Installation Instructions

Before Starting, Read the General Construction Guidelines, Installation Hints, All Typical Detail Sheets and Specific Installation Instructions for Each Component Labeled on Your Plan.

- 1) Dig footing holes spaced as shown on the plan and spec sheets. Refer to the Typical Concrete Footing Spec Sheet.
- 2) Note the post lengths as shown on the plan and set in their appropriate footing holes. The post length is indicated on the finished grade sticker on each post.
- 3) Mark the appropriate posts for the deck heights you are installing and attach decks to posts at marked height. Refer to the appropriate deck spec sheet for installation.
- 4) After all the posts are at proper heights and plumb, and the decks are at proper height and level, pour the concrete footings per the Typical Concrete Footing Spec Sheet.
- 5) Continue installing enclosures and components and pour concrete footings as you progress, making sure everything is plumb and level.
- 6) When installation is complete, install Drive Rivets in all clamps per the Typical Offset Hanger Clamp Spec Sheet.
- 7) Install protective surfacing under and around all equipment before users are allowed to play on the structure.

**DETAIL
ASSEMBLED CLAMP**

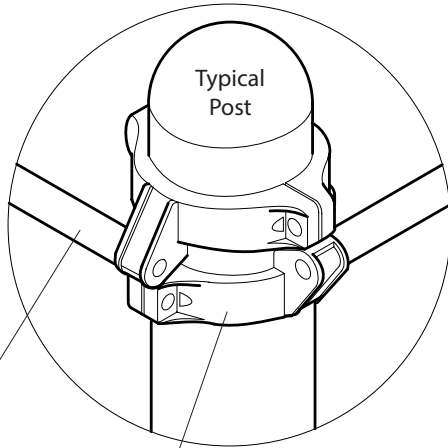

The Offset Hanger Clamp allows rails to be installed at same height for special applications, like at 90° to each other as shown, or when there are clamp conflicts, offset can be positioned upward.

NOTE: A drive rivet is not required in all applications. See General Rules for Use of Drive Rivets for more information.

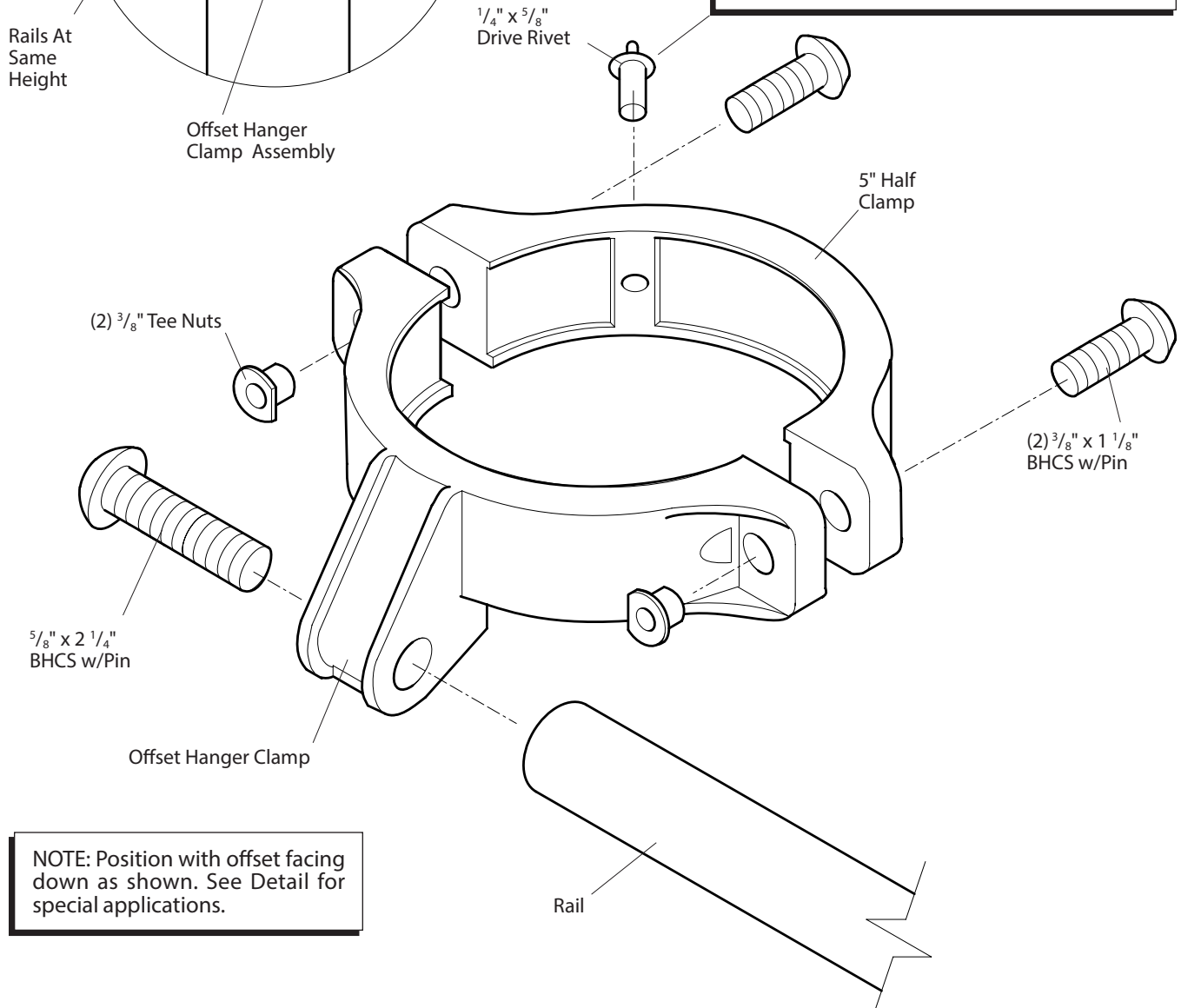

NOTE: Position with offset facing down as shown. See Detail for special applications.

PlayBooster® 114261 Offset Hanger Clamp Assembly



PlayBooster 114261 Offset Hanger Clamp Assembly

J:\SPECS\123\12382100.P65

Parts List

Part#	Description	Qty
100198-00	$\frac{3}{8}$ " x $1 \frac{1}{8}$ " BHCS w/Pin, SST	2
100351-00	$\frac{3}{8}$ " Tee Nut, SST.....	2
100610-00	$\frac{1}{4}$ " x $\frac{5}{8}$ " Drive Rivet, AL/SST	1
105327-01	5" Half Clamp, Specify Color	1
113729-00	Offset Hanger Clamp, Specify Color	1
100203-00	$\frac{5}{8}$ " x $2 \frac{1}{4}$ " BHCS w/Pin, SST	1

Specifications

Clamp: Cast aluminum. Finish: Powdercoat, color specified.

Fasteners: Primary fasteners shall be socketed and pinned tamperproof in design, stainless steel (SST) per ASTM F 879 unless otherwise indicated (see specific product installation/specifications).

Installation Time: Approx. $\frac{1}{4}$ man hour

Weight: 3 lbs.

Installation Instructions

- 1) Locate and mark position of clamp on 5" post.
- 2) Position clamp in proper direction and assemble with $\frac{3}{8}$ " x $1 \frac{1}{8}$ " BHCS w/pin and $\frac{3}{8}$ " tee nuts as shown and lightly tighten. Position rail against clamp and screw in $\frac{5}{8}$ " x $2 \frac{1}{4}$ " BHCS w/pin until rail bottoms out on clamp. Final tighten all fasteners.
- 3) **IMPORTANT:** *Drill through hole in 5" half clamp and into 5" post with a $\frac{1}{4}$ " or "F" (only) drill bit, insert rivet in hole and hammer rivet pin in until it is flush with head.*

120688 is a danger
keep off sign

Not an Install doc.

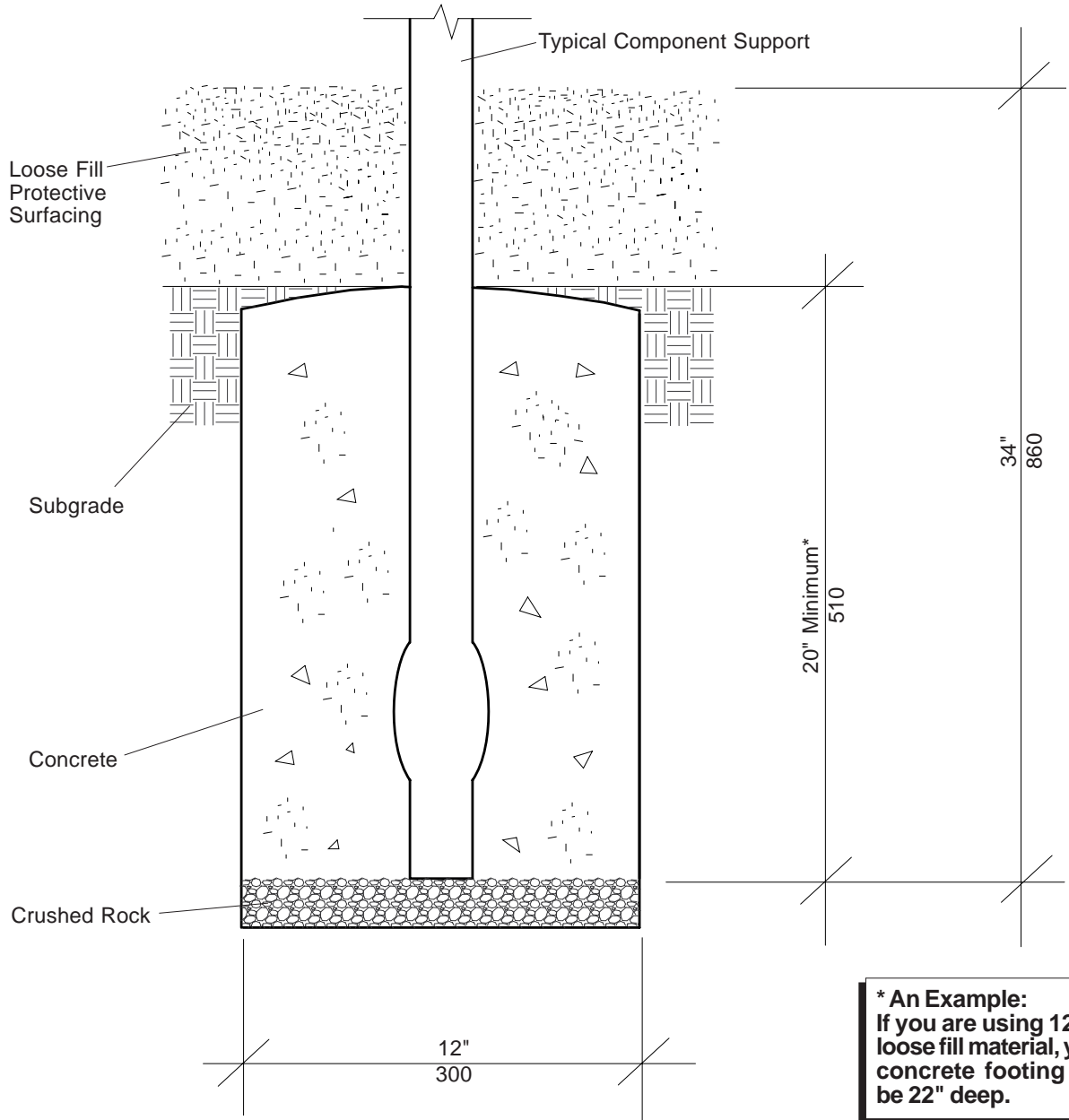

Minimum 1.2 Cubic Feet of Concrete Required per Support.

PlayBooster Installation

- 1) Before starting installation, study your *PlayBooster* plan drawing and all installation instructions carefully for location of posts, deck heights, components and safety enclosures. Make sure slides are oriented away from the afternoon sun and that the structure is visible (easily supervised) and accessible.
- 2) Clear an area large enough for your *PlayBooster* and at least the required minimum use zone around it, as shown on your plan drawing. The subsurface must be well drained. If the soil does not drain naturally it must be tiled or sloped at $\frac{1}{8}$ " to $\frac{1}{4}$ " per foot to a storm sewer or a "French Drain". If your *PlayBooster* is over 30' in length it is recommended to install more than one "French Drain" or similar system to allow drainage from the center of the play area and decrease the overall slope. If this is not possible, the structure may need to be "stepped" to take up the grade change.
- 3) Overhead Obstructions: Overhead obstructions within the use zones of playground equipment that are not part of the play structure (for example, tree limbs) shall be at least 84 in. (2130 mm) above each designated play surface or 84 in. (2130 mm) above the pivot point of swings. All overhead utility line clearances above the use zone areas shall comply with all local, state, and national codes, such as the National Electrical Safety Code.
- 4) Locate all mainstructure post footing holes according to the dimensions shown on your *PlayBooster* plan. This can be accomplished by laying a deck on the ground and measuring from it; by laying out a base line string grid or using a builders transit. This step is very important and worth taking extra time to be precise. Location of component footings such as slide supports can be done at a later time.
- 5) Refer to the Typical Concrete Footing installation sheet. Dig holes to the proper width and depth as shown. (Only dig enough holes for one day's construction. Do not leave holes open over night.) Pour crushed rock in each hole **level with each other** and at least 4" deep as shown. This can be easily accomplished either with a builders transit or by laying out hole locations with a string grid, leveling the grid, and measuring down from the grid for each footing. Tamp the crushed rock down until compacted and at proper level. This step is important to ensure all posts will be at the proper height relative to each other, and it greatly simplifies installation. If the soils are loose or unstable, larger diameter holes may be necessary. Check with a local engineer if in doubt.
- 6) Start with the lowest deck and work your way to the highest deck following instructions on the installation sheets for typical post/deck assembly. Install barriers and roofs as located on the plan for stability.
- 7) After the posts are at proper heights and plumb, and the decks are at proper height and level, pour the concrete footings per the Typical Concrete Footing Detail.
- 8) During construction, the site and all the material on it must be secured when unattended to prevent children from playing on them. Do not leave decks with unprotected openings when unattended-use temporary barricades if necessary.
- 9) Install all other play components per the installation instructions. After all components and enclosures are properly attached, pour the remaining concrete footings per the Typical Concrete Footing Detail.
- 10) Install protective surfacing material.
- 11) Attach play hardware such as 'D' rings and swing seats last, **after** protective surfacing is in place and footings have cured at least 3 days.
- 12) Carefully and thoroughly inspect the entire *PlayBooster* to be sure all fastening hardware is tight. According to ASTM F1487, section 6.2 sharp points, edges and protrusions; any exposed bolt ends should not protrude beyond the face of the nut more than two (2) threads. This condition is not planned, but may exist in some applications because materials and finishes will vary. To remedy this situation, add a second nut or washer(s), extras have been added to the spare parts kit. See illustrations on reverse side of this sheet. Children should not be allowed on the structure until this inspection is complete.
- 13) Before children are allowed on the structure, the site must be cleaned and free of all construction debris and packaging material. Do not burn on the site.

Tools Required

Tools required for installation are an auger, or other equipment for digging 14" diameter footing holes; shovels, rubber mallet, drill (with $\frac{1}{4}$ ", $\frac{7}{16}$ ", $\frac{9}{16}$ ", $\frac{11}{16}$ " and $\frac{3}{8}$ " drill bits), tape measure, hex keys or allen wrenches, level, $\frac{3}{8}$ " socket set, hammer, open end wrench set, screw driver, for surface mount a hammer drill, $\frac{3}{8}$ " and $\frac{1}{2}$ " masonry bits and transit or string line to aid in layout. Some washable felt tip pens are also useful for marking clamp locations.

Materials Required

All *PlayBooster* materials are supplied except concrete for footings, protective surfacing material, and curbing or edging material. With the exception of the special wrenches required (for the pinned hex fasteners) no other tools are supplied.

Recycling

Many of our packaging materials can be recycled, please take the time to separate and deliver them to a recycler. Thank You.

Installation Times

Installation times, as noted on the back of the installation sheets, are *approximate* and will vary depending on soil conditions, installer's equipment and ability. Times indicated *do not* include unloading or unpacking equipment. The man hours given are for one person installing (unless otherwise noted). Cut time in half for two people.

Technical Services

If you have any questions or concerns about the installation of your structure, call our Technical Services Department at: **1-800-328-0035** (7:30 - 5:30p.m. CST/M-F).

Illustrations For Note 10, (Reverse Side Of This Sheet)

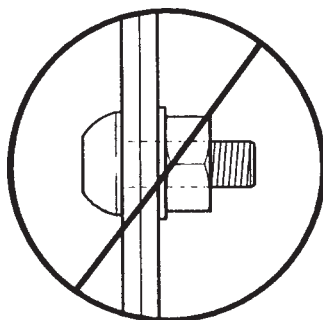

More Than Two (2)
Threads Exposed

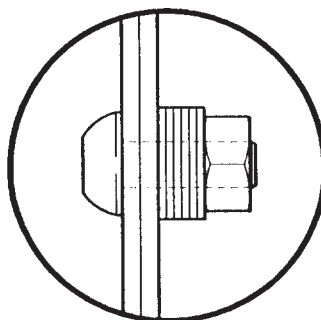

Add Washers

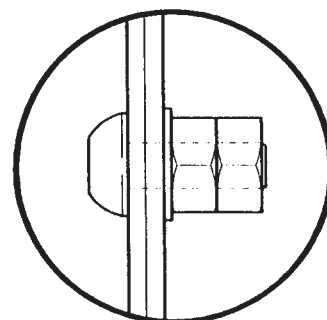

Add Another Nut
(Align Flat Area)

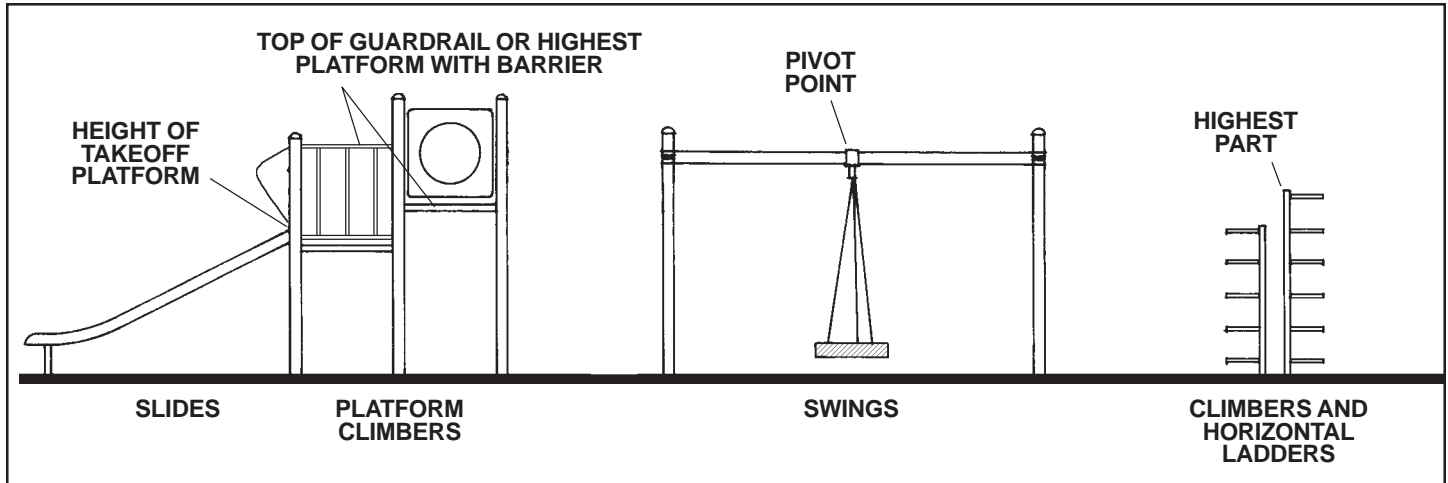

- 1.) Determine the highest accessible part - by definition.
- 2.) Determine the type of surfacing material desired:
 - *Unitary* - Bound rubber type materials for the accessible areas.
 - *Loose-fill* - Sand, wood chips, etc. for non-accessible areas.
- 3.) Select a material that has a Critical Height value of at least the height of the highest accessible part.
 - According to the CPSC, Critical Height is defined as the maximum height from which the instrumented metal headform, upon impact, yields both a peak deceleration of no more than 200 G's and a HIC value of no more than 1,000 when tested in accordance with the procedure described in the ASTM Test Method F1292.
 - Request independent laboratory test results showing the critical height of each product per the above procedures for commercially available products. The CPSC has tested some common loose-fill materials that are commonly not tested as a protective surfacing. (See back page.)
- 4.) Cover the designated use zone with the desired materials. If a different type of material is used for the accessible route of travel, make sure the surfaces are maintained flush.



SAFETY NOTE
 Choose a protective surfacing material that has a Critical Height Value of at least the height of the Highest Accessible Part/Fall Height of the adjacent equipment. (Ref. ASTM F1487.)

Critical Heights (in Feet)

Material	Uncompressed Depth			Compressed Depth *
	6"	9"	12"	9"
* Wood Mulch	7'	10'	11'	10'
* Double Shredded Bark Mulch	6'	10'	11'	7'
* Uniform Wood Chips	6'	7'	12'	6'
* Fine Sand	5'	5'	9'	5'
* Coarse Sand	5'	5'	6'	4'
* Fine Gravel	6'	7'	10'	6'
* Medium Gravel	5'	5'	6'	5'

NA = Not Available

- * **NOTE:** Compressed depths most accurately depict conditions on a playground.
- * An approximation of the maximum fall height from which a life-threatening head injury would not be expected to occur, based on tests in which a headform yielded both a peak deceleration of less than 200 G's and a HIC of less than 1000 upon impact.
- * Handbook for *Public Playground Safety*, published by the U.S. Consumer Products Safety Commission, Section 10, Table 2, page 21.

Critical Heights

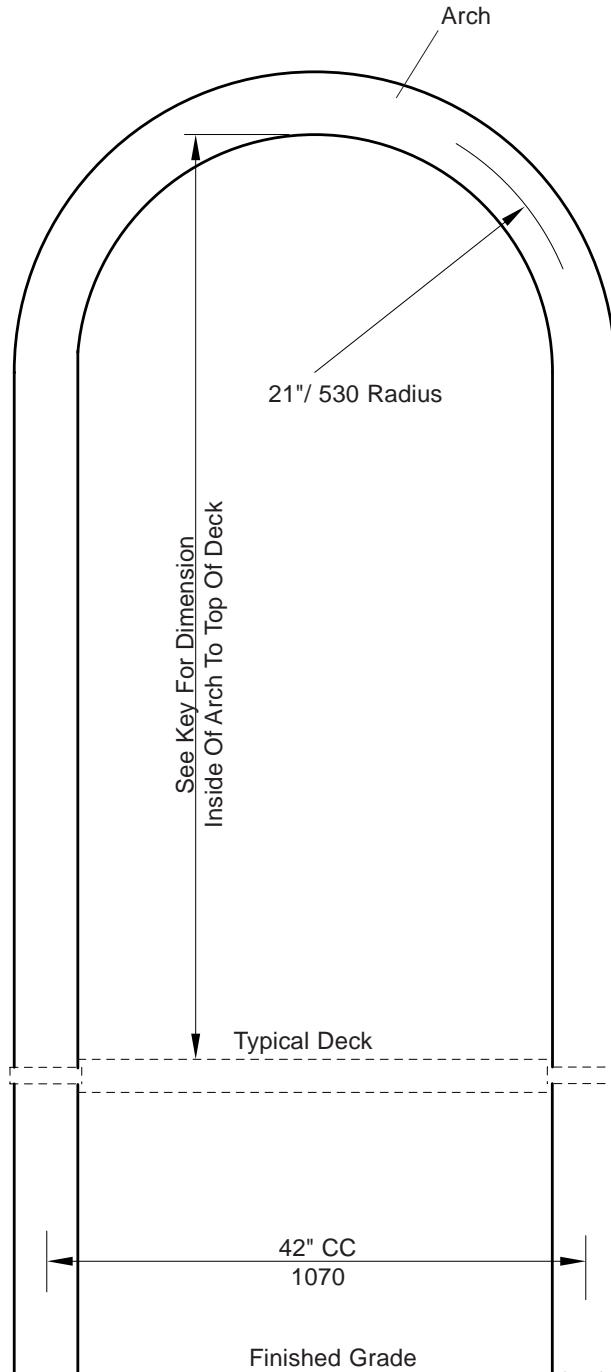

Standard Concrete Footings Required w/ 34"/860 Bury

SPECIFICATIONS:
 Arch formed from 5" O.D. 6005-T5 aluminum tubing with 1/8" wall thickness. Unit is coated with a baked-on polyester powder-coating, color specified.

Key:

Deck Height	Dimension
32"/810	92 1/2"/2350
40"/1020	98 1/2"/2502
48"/1220	90 1/2"/2299
56"/1420	98 1/2"/2502
64"/1630	90 1/2"/2299
72"/1830	90 1/2"/2299
At Grade (No Deck)...	97 1/4"/2470

NOTE:
 Refer To Your Plan For Location Of Arches.

"How to distribute your hardware *Headache Free*"



We have received feedback from you, our customers, that the most common delay in completing your playground installation is lost or misplaced hardware.

Some of our most successful installations have used a "*check-out*" system with one person appointed to distribute the various hardware packages. Installation sheets are provided for each component that indicate hardware packages/items required to assemble that component. Refer to these sheets to determine which hardware items to request from the designated "*check-out*" person.

HELPFUL HINTS:

Read installation sheets.

Be sure to use the correct length hardware as specified on the installation sheets.

Be sure to use clamps in the correct location as indicated on the installation sheets.

Warning

Your playground may include equipment containing moving parts. Moving parts are more vulnerable to wear, mis-use and abuse than other non-moving parts. It is critical these parts be inspected and maintained according to our recommendations.

As the owner, it is your responsibility to perform preventative maintenance and record your findings. Failure to do so may create a hazard and cause serious injury or death.

IMPORTANT SAFETY NOTES!

According to the U.S. Consumer Product Safety Commission (CPSC) nearly 70% of all playground injuries are caused by falls to the surface.

PLEASE INSTALL AND MAINTAIN ADEQUATE PROTECTIVE SURFACING UNDER AND AROUND YOUR PLAYSTRUCTURE!

Never let children play on the equipment before protective surfacing is installed.

Consult the CPSC's Handbook for Public Playground Safety, the ASTM F1487 Standard or your Landscape Structures representative for more information.



Did you know that most of the packaging materials you receive on a Landscape Structures order are recyclable? Do you reuse or recycle everything you can from your playground sites? We're making it easier for you to do the right thing and keep these materials out of landfills!

FOAM/SCRIM SHEETS

Landscape Structures has partnered with our supplier to recycle foam/scrim material, the grey and white sheets that are layered between the large painted parts. This material is not usually accepted at general recycling facilities but this supplier will re-use it in their manufacturing of new packaging materials. It's easy! Just put the foam/scrim from your installation site in a box and ship it to the facility closest to you.

Here is a list of participating facilities throughout the U.S.:

Foam/Scrim Products Only

Pregis Plant
159 N San Antonio Ave.
Pomona, CA 91767

Pregis Plant
8201 W Elwin Ct.
Visalia, CA 93291

Pregis Plant
7574 Presidents Dr.
Orlando, FL 32809

Pregis Plant
1411 Pidco Dr.
Plymouth, IN 46563

Pregis Plant
300 Harris Rd.
Wurtland, KY 41144

Pregis Plant
3825 N Main St.
Granite Falls, NC 28630

Pregis Plant
18 Peck Ave.
Glens Falls, NY 12801

Pregis Plant
3500 S Highway 287
Corsicana, TX 75109

Pregis Plant
310 Old Station Rd.
Wenatchee, WA 98801

Foam/Scrim, Plastic Banding, Shrink Wrap

Anchor Facility
480 Broadway St.
St Paul, MN 55101

Anchor Facility
1501 Swasey Rd.
Hudson, WI 54016

Don't stop here! Most of the other packaging materials can also be recycled, reused or repurposed.

- **CORRUGATED CARDBOARD:** Boxes can be broken down and recycled at a local recycler, or reused for other storage.
- **SHRINK WRAP:** Contact your local plastic recycler and ask if they accept polyethylene plastic.
- **PLASTIC BANDING:** Contact your local plastic recycler and ask if they accept polypropylene.

If you have suggestions for recycling, reusing or repurposing other materials, please email them to: info@playlsi.com. Just one more way Landscape Structures is building healthy, sustainable communities.



Look for compliance to the following guidelines and standards whenever you install playground equipment. It's your assurance that the products you install meet the most rigorous safety and quality assurance standards.

Landscape Structures is a member in good standing of **IPEMA**, the **International Play Equipment Manufacturers Association**. IPEMA is a member-driven, international trade organization that represents and promotes an open market for manufacturers of play equipment.



In the interest of playground safety, IPEMA provides a Third Party Certification Service whereby a designated independent laboratory validates a participant's certification of conformance to ASTM F1487, Standard Consumer Safety Performance Specification for Playground Equipment for Public Use, except sections 7.1.1, 10 and 12.6.1; CAN/CSA Z614, Children's Playspaces and Equipment Standards, except clauses 9.8, 10 and 11; or both. The use of the corresponding logo in the Landscape Structures Inc. catalog signifies that Landscape Structures Inc. has received written validation from the independent laboratory that the product(s) associated with the use of the logo conforms with the requirements of the indicated standards. Check the IPEMA website (www.ipema.org) to confirm product certification. The use zone and fall height requirements in this publication are shown to ASTM standards. The requirements for other standards may be different. According to the CSA, playground maintenance and inspection is a continuous and integral part of budgetary costs. The cost of inspection and maintenance shall be considered and incorporated into the budget at the time of design, purchase equipment and installation (11.1.1 Budgeting).

International Play Equipment Manufacturers Association

4305 N. Sixth St. Suite A
Harrisburg, PA 17110
www.ipema.org



The Consumer Product Safety Commission (CPSC) is a governmental organization that provides technical safety guidelines for designing, constructing, operating and maintaining public playgrounds.

U.S. Consumer Product Safety Commission

4330 East West Hwy.
Bethesda, MD 20814
www.cpsc.gov

The American Society for Testing and Materials (ASTM) is a scientific and technical organization that is a major developer of standards for testing different types of materials. In 1993, the ASTM published "Standard Consumer Safety Performance Specifications for Playground Equipment for Public Use," designation F1487-93. ASTM is more technical than the CPSC. ASTM revised its old standard and published a new standard in 1995, 1998, 2001, 2005, 2007 and again in 2011.

American Society for Testing and Materials

100 Barr Harbor Dr.
P.O. Box C700
West Conshohocken, PA 19428
www.astm.org



The Canadian Standards Association

Nearly all equipment developed by Landscape Structures is certified to meet CAN/CSA-Z614-07, the Children's Playspaces and Equipment Standard, through IPEMA.

The European Standard was developed by the European Committee for Standardization. The majority of Landscape Structures products have been designed to be TUV certified by a third-party validator to EN 1176: 2008, the European Standard for Playground Equipment.



ISO 9001:2008 has a process-orientated structure, is customer focused and emphasizes continuous improvement in quality.



ISO 14001:2004 drives us toward operating in a manner that is environmentally conscious.



PS/PB/FP/Evos/Weevos Guidelines & Standards

601 7TH STREET SOUTH, DELANO, MINNESOTA 55328-8605 (763) 972-3391 1-888-LSI-INST (1-888-574-4678) FAX (763) 972-3185

© 2012 by Landscape Structures. All rights reserved. Eco #54540 Document 18482200 replaces 15749200. Updated document. Document#18482200

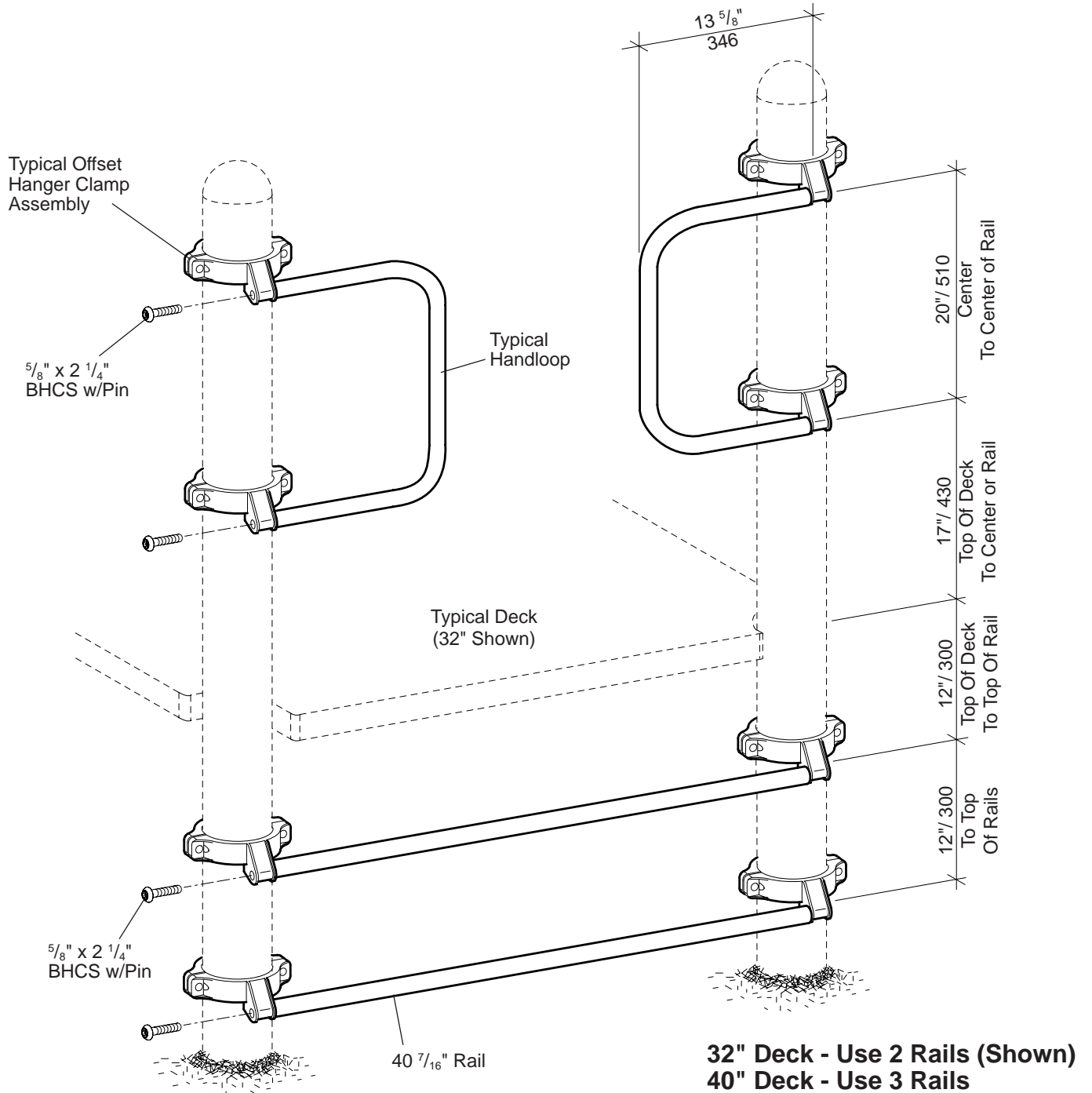

Parts List

Part#	Description	Qty.
111275	Handloop Assembly	1
108542	Handloop, Specify Color	1
100198	$\frac{3}{8}$ " x $1\frac{1}{8}$ " BHCS w/Pin, SST	4
100203	$\frac{5}{8}$ " x $2\frac{1}{4}$ " BHCS w/Pin, SST	2
100351	$\frac{3}{8}$ " Tee Nut, SST.....	4
100610	$\frac{1}{4}$ " x $\frac{5}{8}$ " Drive Rivet, SST	2
105327	5" Half Clamp, Specify Color	2
113729	Offset Hanger Clamp, Specify Color	2
111276	Rail Assembly	1
108569	Rail, Specify Color	1
100198	$\frac{3}{8}$ " x $1\frac{1}{8}$ " BHCS w/Pin, SST	4
100203	$\frac{5}{8}$ " x $2\frac{1}{4}$ " BHCS w/Pin, SST	2
100351	$\frac{3}{8}$ " Tee Nut, SST.....	4
100610	$\frac{1}{4}$ " x $\frac{5}{8}$ " Drive Rivet, SST	2
105327	5" Half Clamp, Specify Color	2
113729	Offset Hanger Clamp, Specify Color	2

Specifications

Handloop: Weldment comprised of 1.125" O.D. 11 GA (.120") steel tubing with 203 or 303 stainless steel inserts, with $\frac{5}{8}$ " internal thread. Finish: TenderTuff™, color specified.

Rail: Weldment comprised of 1.125" O.D. 11 GA (.120") steel tubing with 203 or 303 stainless steel inserts, with $\frac{5}{8}$ " internal thread. Finish: TenderTuff™, color specified.

Offset Hanger Clamp Assembly: Cast aluminum. Finish: ProShield®, color specified.

Fasteners: Primary fasteners shall be socketed and pinned tamperproof in design, stainless steel (SST) per ASTM F 879 unless otherwise indicated (see specific product installation/specifications).

Installation Time: Approx. $\frac{3}{4}$ man hour

Weight: 111275-00 (One) 11 lbs.
111276-00 (One) 11 lbs.

Installation Instructions

- 1) Mark locations of clamps on posts per dimensions on front of sheet.
- 2) Attach offset clamps to ends of rails/handloops using $\frac{5}{8}$ " x $2\frac{1}{4}$ " BHCS w/pin.
- 3) Position rail/handloop on marked position on posts and attach using 5" half clamps and $\frac{3}{8}$ " x $1\frac{1}{8}$ " BHCS w/pin with $\frac{3}{8}$ " tee nuts. Refer to the Typical Offset Hanger Clamp Assembly Sheet.
- 4) Install drive rivets in half clamps per the Typical Offset Hanger Clamp Assembly Sheet.
- 5) Install protective surfacing before users are allowed to play on the structure.

Post Specifications: Post length shall vary depending upon the intended use and shall be a minimum of 42" above the deck height. All posts shall be powdercoated to specified color. All posts shall have a "finished grade marker" positioned on the post identifying the 34" bury line (or 44" bury line for posts for 96" decks) required for correct installation and the top of the loose fill protective surfacing. Top caps for posts shall be aluminum die cast from 369.1 alloy and powdercoated to match the post color. All caps shall be factory installed and secured in place with (3) self sealing rivets. A molded low density polyethylene cap, with drain holes, shall be pressed onto the bottom end of the post to increase the footing area.

Steel Posts: All steel PlayBooster posts are manufactured from 5" O.D. tubing with a wall thickness of .120" and shall be galvanized after rolling and shall have both the I.D. and the cut ends sprayed with a corrosion resistant coating.

Aluminum Posts: All aluminum PlayBooster posts are manufactured from 6005-T5 extruded tubing conforming to ASTM B-221. Posts shall have a 5" outside diameter with a .125" wall thickness.

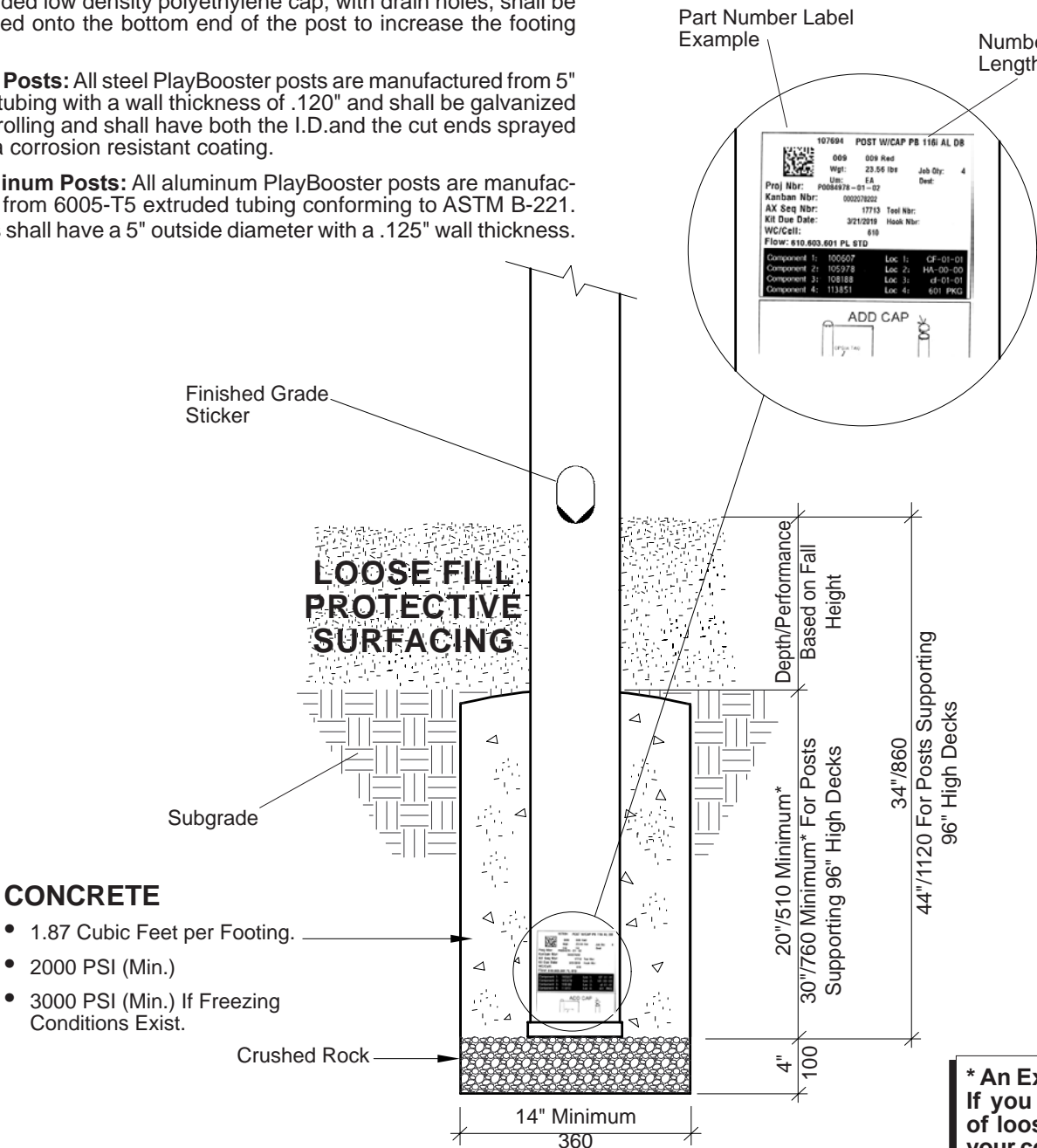

*** An Example:**
If you are using 12" of loose fill material, your concrete footing will be 22" deep.

PlayBooster® Concrete Footings, 5" Posts

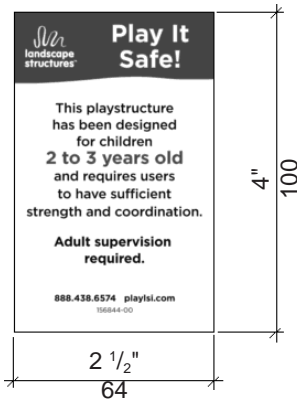

Part No. 156844-00-000

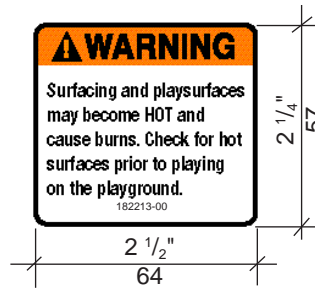

Part No. 182213-00-000



Part No. 115176-00-000

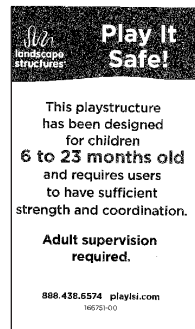
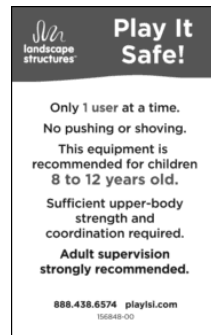
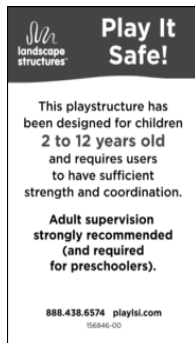

Part No. 182212-00-000

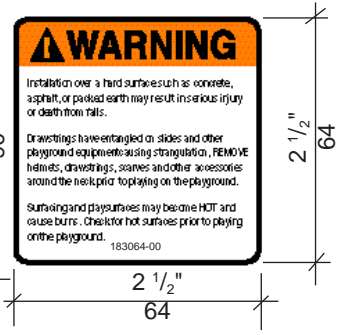

Part No. 183064-00-000

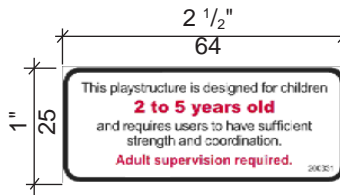
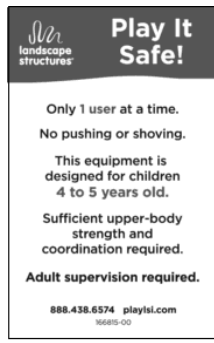
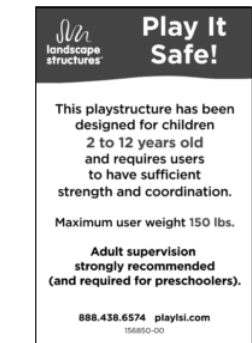

Part No. 200331-00-000



Part No. 200332-00-000



Part No. 200333-00-000

NOTE: The Playstructure design will determine which Play It Safe sticker will be supplied.

INSTRUCTIONS:

Surface must be clean and dry prior to applying sticker. Peel backing sheet away from back of sticker and place sticker in position. Using backing sheet, rub over face of sticker to burnish down into place. Choose a location visible to adults in a conspicuous location on product. Stickers work best on painted parts. Where possible, avoid placing on rotationally-molded plastic parts, TenderTuff-coated parts or where children may step and wear off sticker. This applies to both Freestanding Play items and Composite Playstructures. Apply sticker adjacent to or visible from the primary entrance to the structure. Apply 4'-5' above the surface. Apply at least (1) one to every structure and (2) two to large Composite Playstructures.

Part No. 156847-00-000

Part No. 156845-00-000



SAFETY NOTE
 Choose a protective surfacing material that has a Critical Height Value of at least the height of the Highest Accessible Part/Fall Height of the adjacent equipment. (Ref. ASTM F1487.)

- 251714 5i Formed Play Safe Plate 6-23 Months w/Attaching HDW
- 251736 5i Formed Play Safe Plate 2-5 Years w/Attaching HDW
- 251712 5i Formed Play Safe Plate 2-12 Years w/Attaching HDW
- 251713 5i Formed Play Safe Plate 5-12 Years w/Attaching HDW
- 251715 5i Formed Play Safe Plate 1.5-5 Years w/Attaching HDW
- 251716 5i Formed Play Safe Plate 1.5-12 Years w/Attaching HDW

- 251720 3.5i Formed Play Safe Plate 6-23 Months w/Attaching HDW
- 251717 3.5i Formed Play Safe Plate 2-5 Years w/Attaching HDW
- 251718 3.5i Formed Play Safe Plate 2-12 Years w/Attaching HDW
- 251719 3.5i Formed Play Safe Plate 5-12 Years w/Attaching HDW
- 251721 3.5i Formed Play Safe Plate 1.5-5 Years w/Attaching HDW
- 251722 3.5i Formed Play Safe Plate 1.5-12 Years w/Attaching HDW

- 251726 Flat Large Play Safe Plate 6-23 Month w/Attaching HDW
- 251723 Flat Large Play Safe Plate 2-5 Years w/Attaching HDW
- 251724 Flat Large Play Safe Plate 2-12 Years w/Attaching HDW
- 251725 Flat Large Play Safe Plate 5-12 Years w/Attaching HDW
- 251727 Flat Large Play Safe Plate 1.5-5 Years w/Attaching HDW
- 251728 Flat Large Play Safe Plate 1.5-12 Years w/Attaching HDW

- 251731 Flat Small Play Safe Plate 6-23 Month w/Attaching HDW
- 251729 Flat Small Play Safe Plate 2-5 Years w/Attaching HDW
- 251730 Flat Small Play Safe Plate 2-12 Years w/Attaching HDW
- 251735 Flat Small Play Safe Plate 5-12 Years w/Attaching HDW
- 251732 Flat Small Play Safe Plate 1.5-5 Years w/Attaching HDW
- 251733 Flat Small Play Safe Plate 1.5-12 Years w/Attaching HDW

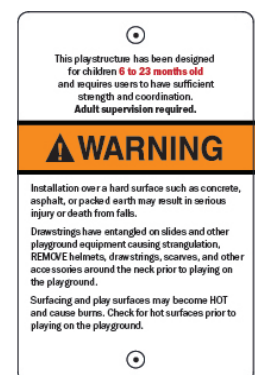

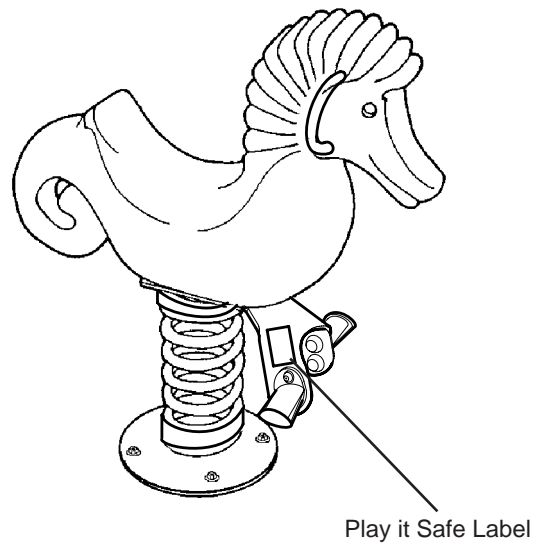
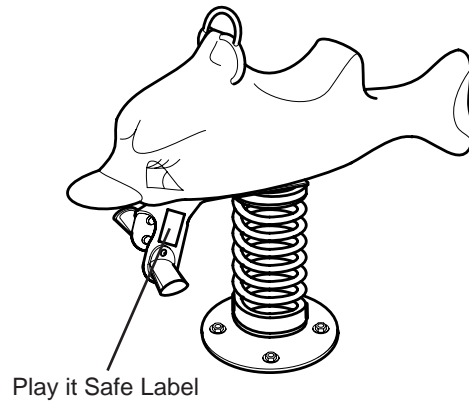
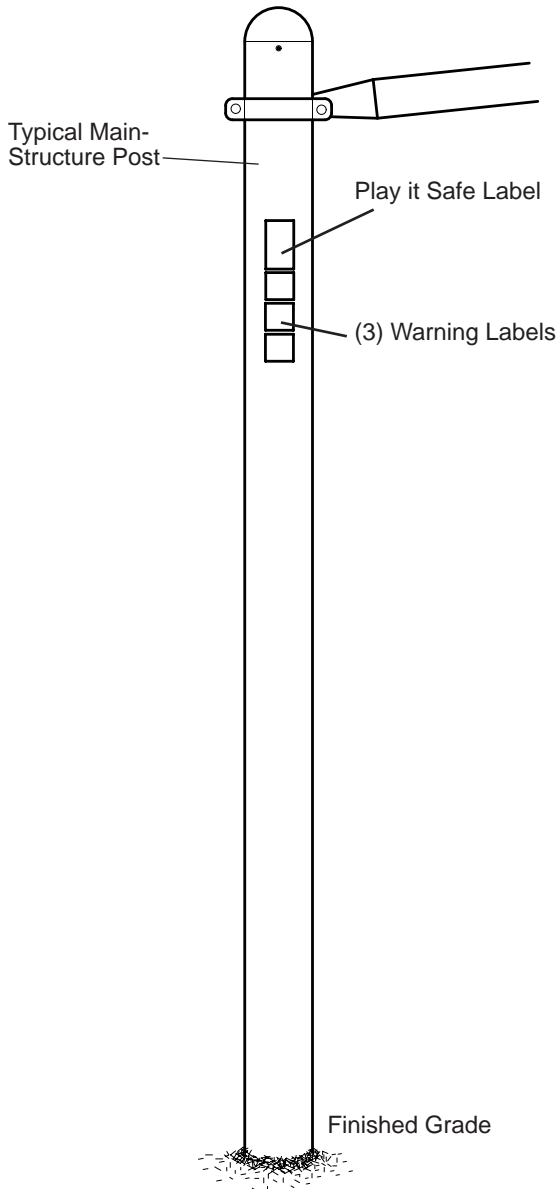

Warning Labels

5" formed plate mounts to 5" posts.
 3.5" formed plate mounts to 3.5" posts

Large flat plate mounts to flat surfaces

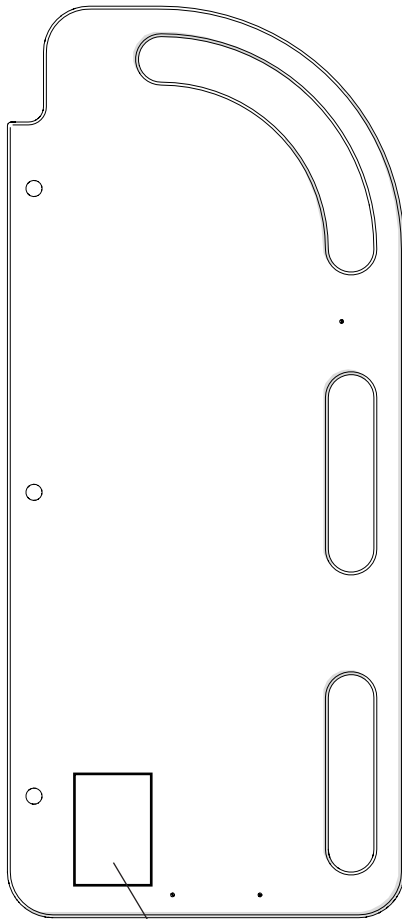

To attach to permalene
 1) Hold plate on surface in location
 2) Mark holes
 3) Drill 1/8" x 1/2" deep holes for installation

Typical Main-
 Structure Post

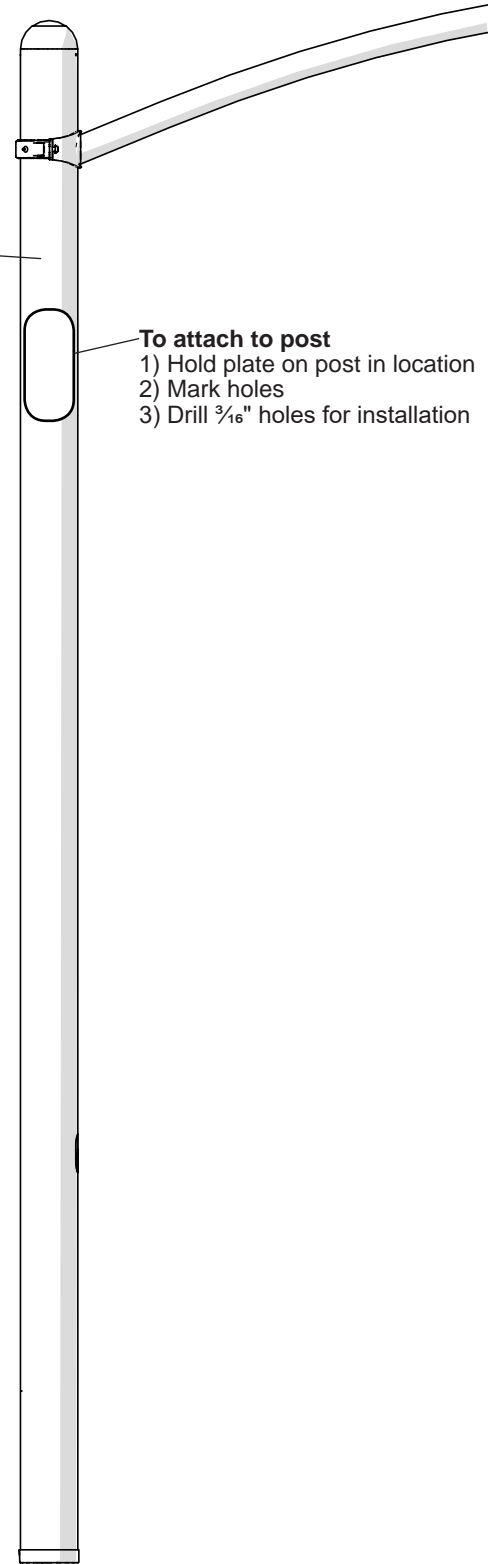

To attach to post
 1) Hold plate on post in location
 2) Mark holes
 3) Drill 3/16" holes for installation



landscape
structures®



Common Parts & Fasteners

Button Head Cap Screws BHCS w/Pin

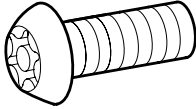

Part #	Inches	Sizes mm	Mat'l or Grade	Recommended Torque	
				Ft./lbs	Kgm
137277	1/4" x 3/8"	(6,4 x 9,5)	SST-PAT	10	1.4
131849	5/16" x 1/2"	(7,9 x 12,7)	SST-PAT	10	1.4
223807	5/16" x 3/4"	(7,9 x 19,0)	SST-PAT	10	1.4
132626	5/16" x 7/8"	(7,9 x 22,2)	SST-PAT	10	1.4
192071		M 8 x 24 mm	SST-PAT	10	1.4
100195	3/8" x 5/8"	(9,5 x 15,9)	SST-PAT	15	2
100196	3/8" x 7/8"	(9,5 x 22,2)	SST-PAT	15	2
100198	3/8" x 1 1/8"	(9,5 x 28,6)	SST-PAT	15	2
113027	3/8" x 1 3/8"	(9,5 x 34,9)	SST-PAT	15	2
100171	3/8" x 1 1/2"	(9,5 x 38,1)	SST-PAT	15	2
123224	3/8" x 1 11/16"	(9,5 x 42,9)	SST-PAT	15	2
100173	3/8" x 2"	(9,5 x 50,8)	SST-PAT	15	2
100199	3/8" x 2 1/4"	(9,5 x 57,2)	SST-PAT	15	2
100174	3/8" x 2 1/2"	(9,5 x 63,5)	SST-PAT	15	2
100175	3/8" x 2 3/4"	(9,5 x 69,9)	SST-PAT	15	2
100176	3/8" x 3"	(9,5 x 76,2)	SST-PAT	15	2
100168	3/8" x 3 1/4"	(9,5 x 82,6)	SST-PAT	15	2
100200	3/8" x 3 1/2"	(9,5 x 88,9)	SST-PAT	15	2
124460	3/8" x 3 3/4"	(9,5 x 95,2)	SST-PAT	15	2
100201	5/8" x 1 1/2"	(15,9 x 38,1)	SST-PAT	50	7
127551	5/8" x 1 1/2"	(15,9 x 38,1)	SST- ANTI-SEIZE	50	7
100203	5/8" x 2 1/4"	(15,9 x 57,2)	SST-PAT	50	7

Carriage Bolts

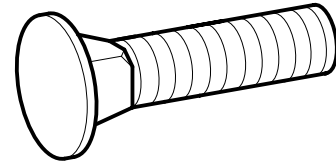

Part #	Inches	Sizes mm	Mat'l or Grade	Recommended Torque	
				Ft./lbs	Kgm
100135	5/16" x 1 1/4"	(7,9 x 31,8)	SST-PAT	5	0.7
100147	3/8" x 1 1/4"	(9,5 x 31,8)	SST-PAT	15	2
116017	3/8" x 1 1/2"	(9,5 x 38,1)	SST-PAT	15	2
100148	3/8" x 1 3/4"	(9,5 x 44,5)	SST-PAT	15	2

Flat Head Cap Screws (FHCS)

No Pin*

With Pin

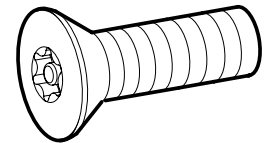
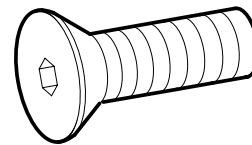

Part #	Inches	Sizes mm	Mat'l or Grade	Recommended Torque	
				Ft./lbs	Kgm
148686	3/8" x 3/4"	(9,5 x 19,05)	SST-PAT	13	1.8
100252*	3/8" x 1 1/4"	(9,5 x 31,8)	SST-PAT	13	1.8
151421	3/8" x 1 1/2"	(9,5 x 38,1)	SST-PAT	13	1.8
148765	3/8" x 3 1/2"	(9,5 x 88,9)	SST-PAT	13	1.8
130824*	1/2" x 2 1/4"	(12,5 x 57,2)	SST	20	2.8

Hex Cap Screws

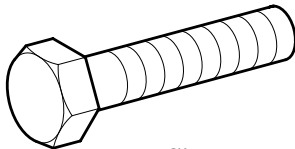

Part #	Inches	Sizes mm	Mat'l or Grade	Recommended Torque	
				Ft./lbs	Kgm
100206	3/8" x 1"	(9,5 x 25,4)	SST-PAT	15	2
100208	3/8" x 1 1/2"	(9,5 x 38,1)	SST-PAT	15	2
100209	3/8" x 1 3/4"	(9,5 x 44,4)	SST-PAT	15	2
135682	3/8" x 3 1/8"	(9,5 x 79,3)	SST-PAT	15	2
135683	3/8" x 4 5/8"	(9,5 x 117,5)	SST	15	2
100214	3/8" x 5"	(9,5 x 127)	SST-PAT	15	2
121499	7/16" x 1 3/4"	(11,1 x 114,3)	SST-PAT	15	2
100216	1/2" x 1 1/4"	(12,7 x 31,7)	SST	15	2
131862	1/2" x 2 1/4"	(12,7 x 57,1)	SST-PAT	20	2.8

NOTE: These are recommended torque applications per fastener size. When fasteners are used with plastic or wood products, the torque specifications will be excessive and we recommend that the installer apply some caution when tightening the fasteners. Plastic or wood products should begin to deform slightly. Fasteners indicated with "-Pat" includes a locking patch type material and should cure for 72 hours for maximum strength.

PS/PB/Evos/Weevos Common Parts/Torque Chart

Sheet 1 of 3

601 7TH STREET SOUTH, DELANO, MINNESOTA 55328-8605 888-574-4678 LSI Install Help 888-438-6574 LSI Direct 763-972-5200 Int. FAX (763) 972-3185

© 2019 by Landscape Structures. All rights reserved.

Document #25914300

BHCS w/Pin Limited Thread Bolts

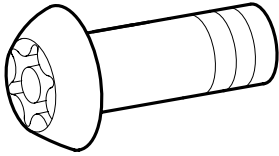

Part #	Sizes		Mat'l or Grade	Recommended Torque	
	Inches	mm		Ft./lbs	Kgm
100290	3/8" x 7/8"	(9,5 x 22,2)	SST-PAT	21	3
100292	3/8" x 1 1/4"	(9,5 x 31,8)	SST-PAT	21	3
157704	7/16" x 2"	(11,11x 51)	SST-PAT	40	5.5
127068	7/16" x 2 7/16"	(11,11x61,91)	SST-PAT	40	5.5

Lag Screws

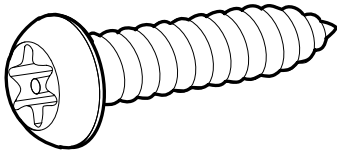

Part #	Sizes		Mat'l or Grade	Head Type
	Inches	mm		
100127	5/16" x 1 1/4"	(7,9 x 31,8)	SST	Hex Head
168198 (Shown)	3/8" x 1 1/2"	(9,5 x 38,1)	SST	Button Head
139039 (Shown)	3/8" x 2"	(9,5 x 50,8)	SST	Button Head

Screw, Type AB Thread BHCS w/Pin

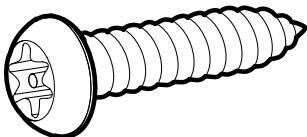

Part #	Size	Mat'l or Grade
129671	#14 x 1/2"	SST
127872	#14 x 3/4"	SST
136232	#14 x 1"	SST
129672	#14 x 1 1/4"	SST

Expansion Anchors (Used To Secure Components To Concrete Slabs)

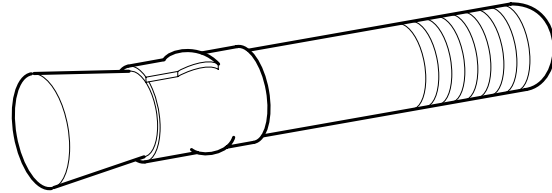

Part #	Sizes		Mat'l or Grade	Recommended Torque	
	Inches	mm		Ft./lbs	Kgm
100263	3/8" x 2 3/4"	(9,5 x 69,9)	Alloy Steel	15	2
100266	1/2" x 2 3/4"	(12,7 x 69,9)	Alloy Steel	20	2.8

Drive Rivets

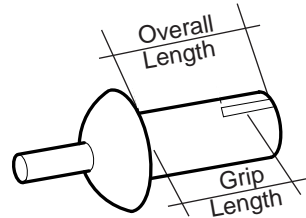

NOTE: For more detail see drive rivet detail page.

Part #	Sizes		Mat'l
	Inches	mm	
100612	3/16" x 3/8"	(4,7 x 9,5)	Alum Rivet/Alum Pin
100609	1/4" x 3/16"	(6,4 x 4,8)	Alum Rivet/Alum Pin
100611	1/4" x 3/8"	(6,4 x 9,5)	Alum Rivet/SST Pin
113300	1/4" x 1/2"	(6,4 x 12,7)	Alum Rivet/Alum Pin
100610	1/4" x 5/8"	(6,4 x 15,9)	Alum Rivet/SST Pin
139152	1/4" x 3/4"	(6,4 x 19,05)	Alum Rivet/Alum Pin
100613	1/4" x 7/8"	(6,4 x 22,2)	Alum Rivet/Alum Pin
118158	1/4" x 1"	(6,4 x 25,4)	Alum Rivet/Alum Pin

Low Crown Cap Nut

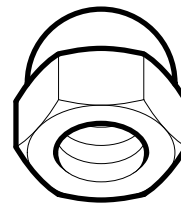

Part #	Size Inches	Mat'l
100349	3/8" -16 UNC	SST

Standard Hex Nuts

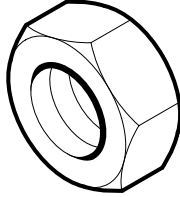

Part #	Sizes Inches	Mat'l or Grade
100326	5/16-18 UNC	SST
100321	3/8-16 UNC	SST-Pat
100327	3/8-16 UNC	SST
128296	3/8-16 UNC (Jam Nut)	SST
100328	7/16-14 UNC	SST
145021	7/16-14 UNC (Jam Nut)	SST
100322	1/2-13 UNC	SST
129692	1/2-13 UNC	SST-Pat
129693	1/2-13 UNC (Jam Nut)	SST
100323	5/8-11 UNC	SST

Flange Nut w/Pin

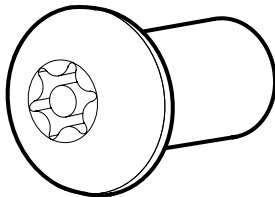

Part #	Sizes Inches	Mat'l or Grade
175006	5/16 x 18 UNC	SST
192064	M 8 x 24 mm	SST
100353	3/8-16 UNC	SST

Flat Washers

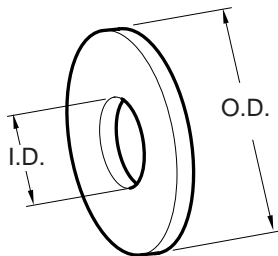

Part #	Sizes Inches	mm	or Grade	I.D.	O.D.
122039	1/4"	(6,3)	SST	0.312	.734
100362	3/8"	(9,5)	SST	0.406	1.002
112793	7/16"	(11,1)	SST	0.505	1.262
100363	1/2"	(12,7)	SST	0.536	1.262
100366	5/8"	(15,9)	SST	0.688	1.750
123737	1 1/8"	(28,6)	SST	1.140	1.750

Curved Spring Washer

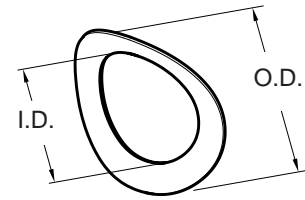

Part #	Sizes Inches	mm	Mat'l or Grade	I.D.	O.D.
100380	1/2"	(12,7)	SST	0.531	0.795

SAE Flat Washers

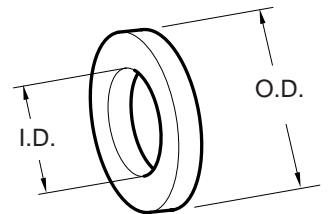

Part #	Sizes Inches	mm	Mat'l or Grade	I.D.	O.D.
100364	1/4"	(6,35)	SST	0.281	0.625
223956	5/16"	(7,92)	SST	0.344	0.688
100365	3/8"	(9,5)	SST	0.411	0.816
113550	1/2"	(12,7)	SST	0.531	1.062
129500	5/8"	(15,9)	SST	0.686	1.342

Fender Washers

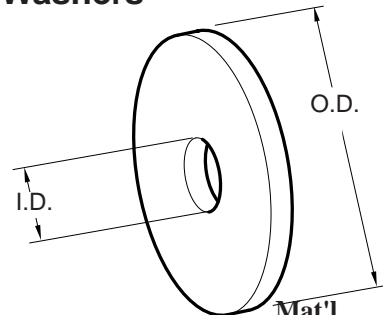

Part #	Sizes Inches	mm	Mat'l or Grade	I.D.	O.D.
100378	3/8" x 1 1/2"	(9,53 x 38,1)	SST	0.406	1.500
100379	1/2" x 2"	(12,7 x 50,8)	SST	0.531	2.000

Tee Nut (PlayBooster Clamps)

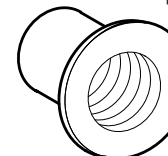

Part #	Sizes Inches	Mat'l or Grade
100351	3/8-16 UNC	SST

Set Screw

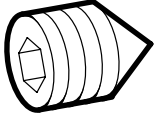

Part #	Sizes		Mat'l or Grade
	Inches	mm	
100298	3/8" x 7/16"	(9,5 x 11,1)	SST

Bolt Link



Part #	Mat'l or Grade
138915	SST

Double Clevis

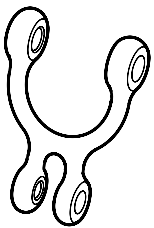

Part #	Mat'l or Grade
138917	SST

Offset Hanger Clamp (PlayBooster)

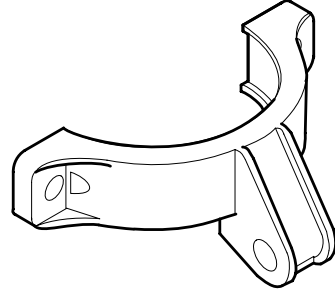

Part #	Mat'l
113729	Cast Aluminum

Half Clamp (PlayBooster)

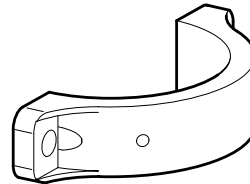

Part #	Mat'l
105327	Cast Aluminum

Deck Hanger Clamp (PlayBooster)

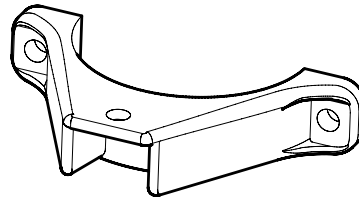

Part #	Mat'l
106022	Cast Aluminum

Swing Hanger Clamp

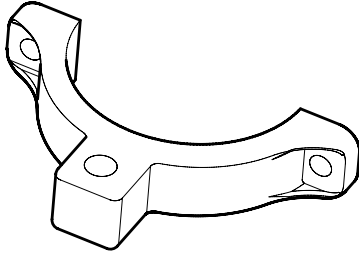

Part #	Mat'l
121289	Cast Aluminum

Ring/Rail Hanger Clamp (PlayBooster)

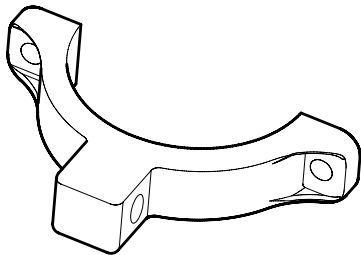

Part #	Mat'l
105330	Cast Aluminum

Offset Bolt Bracket (PlayShaper)

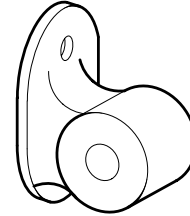

Part #	Mat'l
113895	Cast Aluminum

Hex-Pin Allen Wrench

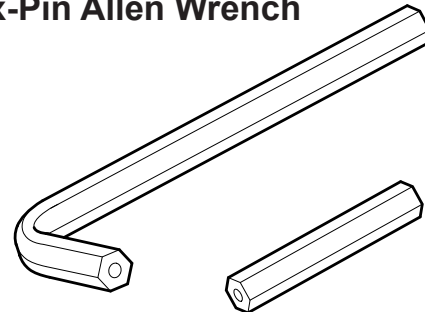

Hex-Pin Driver

Part #	Description
100685	Hex-Pin Allen Wrench
100686	Hex-Pin Driver (Used With A 5/16" Socket)

6-Lobe Wrench

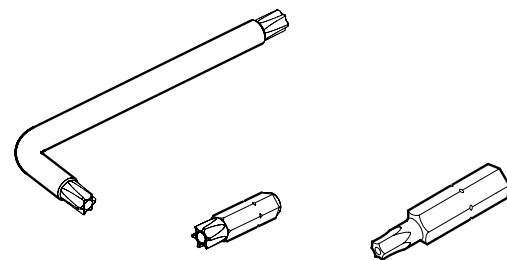

6-Lobe Driver

Torx-Pin Driver

Part #	Description
148680	6-Lobe Wrench (T-40)
146017	6-Lobe Wrench (T-45)
146007	6-Lobe Driver (T-45) (Used With A 5/16" Socket)
127463	Torx-Pin Driver (T-27) (Used With A 1/4" Socket)

HOW TO DETERMINE BOLT LENGTHS

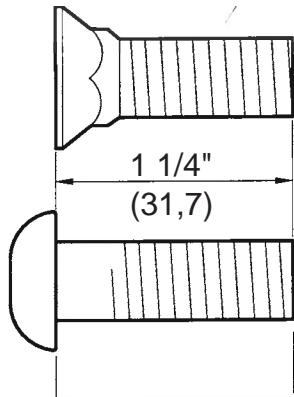

Example shows a 1 1/4" long plow bolt. Measurement method also applies to flathead cap screws.

Example shows a 1 1/4" long BH cap screw. Measurement method also applies to hex cap screws, limited thread bolts, lag screws and carriage bolts.

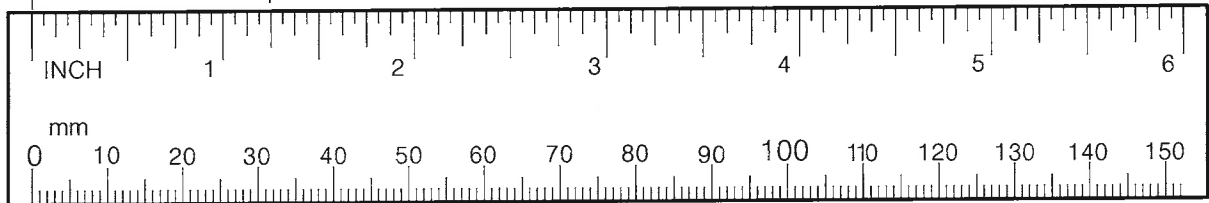

Rule: Measurements should be based on the part of the screw that penetrates the surface.

Drive Rivets Details

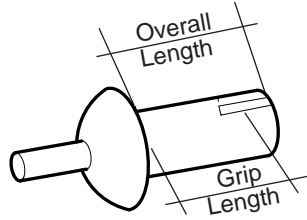

GL = Grip Length
OL = Overall Length

Drive Rivet



100609
1/4" x 3/16" GL (6,4 x 4,8)
1/4" x 11/32" OL (6,4 x 8, 7)
Alum Rivet/ Alum Pin

Common Use

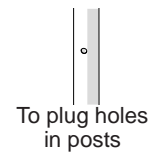

To plug holes
in posts

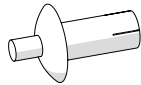

100611
1/4" x 3/8" GL (6,4 x 9,5)
1/4" x 17/32" OL (6,4 x 13, 5)
Alum Rivet/ SST Pin

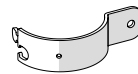

218924
Locking Clamp



192691
Post Topper

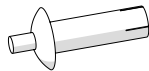

100610
1/4" x 5/8" GL (6,4 x 15,9)
1/4" x 51/64" OL (6,4 x 20, 2)
Alum Rivet/ SST Pin



105327
5" Half Clamp

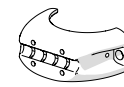

195922
Rope Clamp



156806
Pod Casting

Other Speciality Drive Rivets



100613
1/4" x 7/8" GL (6,4 x 22,2)
1/4" x 63/64" OL (6,4 x 25, 4)
Alum Rivet/ Alum Pin

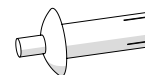

113300
1/4" x 1/2" GL (6,4 x 12,7)
1/4" x 21/32" OL (6,4 x 16, 7)
Alum Rivet/ Alum Pin



118158
1/4" x 7/8" GL (6,4 x 25,4)
1/4" x 1 5/32" OL (6,4 x 29, 3)
Alum Rivet/ Alum Pin

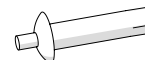

139152
1/4" x 3/4" GL (6,4 x 19,05)
1/4" x 29/32" OL (6,4 x 23, 0)
Alum Rivet/ Alum Pin

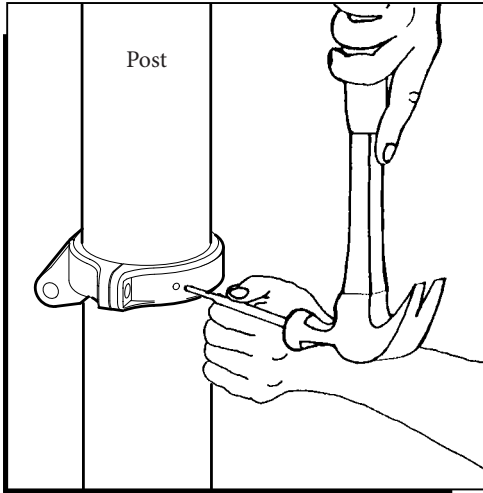

- 1) **Drive Center Pin of Rivet Straight into Post Using $\frac{1}{8}$ " Diameter Punch and Hammer.**

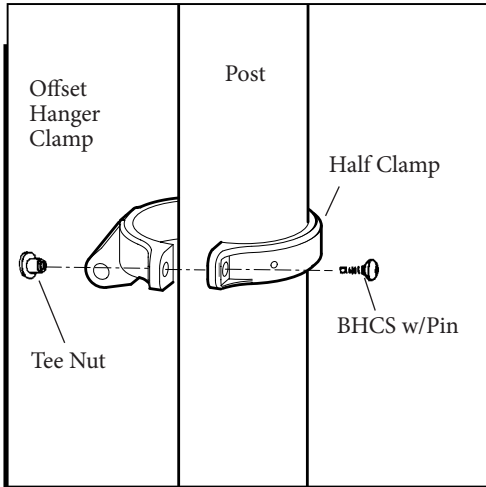

- 2) **Unbolt BHCS w/Pin and Tee Nuts from Clamp Using Tamperproof Hex Wrench. Remove Offset Hanger Clamp. Lightly Tap on Half Clamp with Hammer Until Head of Drive Rivet Pulls Away From Half Clamp.**

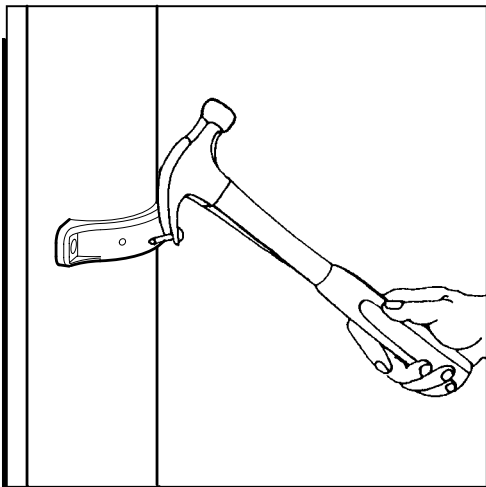

- 3) **Pull Out Drive Rivet Using Claw End of Hammer.**

- | |
|--|
| <p>Tools Needed:</p> <ul style="list-style-type: none"> • Claw Hammer • $\frac{1}{8}$" Diameter Steel Punch • Tamperproof Hex Wrench |
|--|

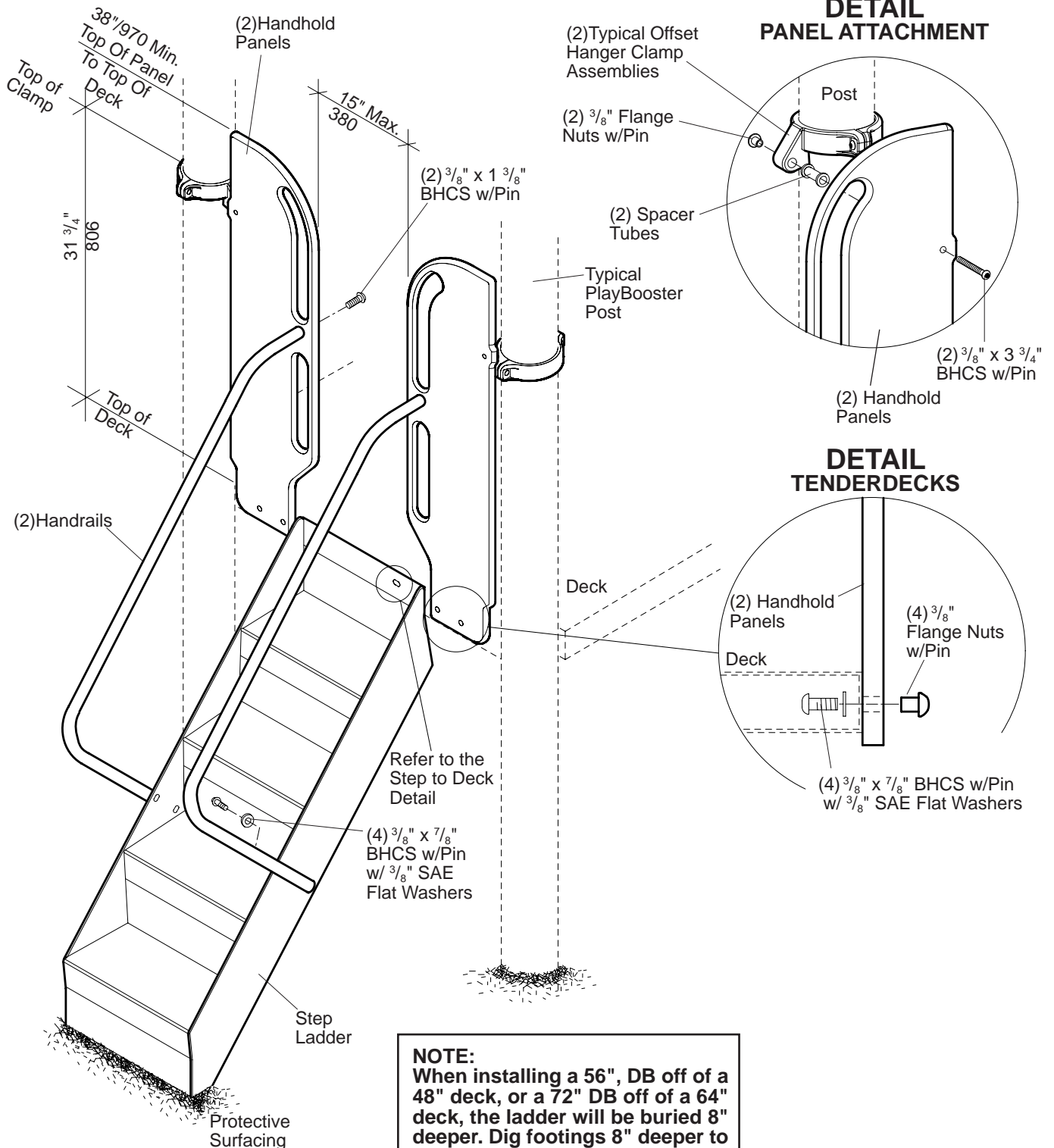

NOTE:
 When installing a 56", DB off of a 48" deck, or a 72" DB off of a 64" deck, the ladder will be buried 8" deeper. Dig footings 8" deeper to compensate.

Off 40" Deck (Shown)



PlayBooster® 116246 Step Ladders, 32"-72" Decks

Parts List

Part#	Description	Qty.
108534	32" Step Ladder, Specify Color.....	1
108563	40" Step Ladder, Specify Color.....	1
211511	56" Step Ladder, Specify Color.....	1
211513	72" Step Ladder, Specify Color.....	1
126005	Handrail 32" Deck RH, Specify Color.....	1
126002	Handrail 32" Deck LH, Specify Color.....	1
125999	Handrail 40" Deck RH, Specify Color.....	1
125996	Handrail 40" Deck LH, Specify Color.....	1
125989	Handrail 56" Deck RH, Specify Color.....	1
125988	Handrail 56" Deck LH, Specify Color.....	1
125983	Handrail 72" Deck RH, Specify Color.....	1
125110	Handrail 72" Deck LH, Specify Color.....	1
139563	Handhold Panel, Specify Color.....	2
105327	5" Half Clamp, Specify Color.....	2
113729	Offset Hanger Clamp, Specify Color.....	2
113468	Spacer Tube, Specify Color.....	2
180688	Support (DB), Specify Color.....	1
180690	Support (SM), 72" Step Ladr. Only, Specify Color.....	1

123723	Clamp Hardware Package	1
100198	3/8" x 1 1/8" BHCS w/Pin, SST	4
100351	3/8" Tee Nut, SST.....	4

139608	32" - 56" Step Ladder Hdw. Pkg. (Tenderdeck)	1
124460	3/8" x 3 3/4" BHCS w/Pin, SST	2
100196	3/8" x 7/8" BHCS w/Pin, SST	12
100327	3/8" Standard Hex Nut, SST	4
100353	3/8" Flange Nut w/Pin, SST	6
100365	3/8" SAE Flat Washer, SST.....	14
113027	3/8" x 1 3/8" BHCS w/Pin, SST	2

139609	72" Step Ladder Hardware Pkg. (Tenderdeck)	1
124460	3/8" x 3 3/4" BHCS w/Pin, SST	2
100196	3/8" x 7/8" BHCS w/Pin, SST	16
100327	3/8" Standard Hex Nut, SST	4
100353	3/8" Flange Nut w/Pin, SST	6
100365	3/8" SAE Flat Washer, SST.....	18
113027	3/8" x 1 3/8" BHCS w/Pin, SST	2

121256	2 Hole (SM) Hardware Package	1
100263	3/8" x 2 3/4" Expansion Anchor	2
100327	3/8" Standard Hex Nut, SST	2
100365	3/8" SAE Flat Washer, SST.....	2

DB = Direct Bury
SM = Surface Mount
RH = Right Hand
LH = Left Hand

Specifications

- Ladder:** Fabricated and formed from 14 GA (.075") HRPO sheet steel with 5/16" perforated holes for steps and welded 12 GA (.105") HRPO sheet steel for sides. Finish: TenderTuff™, color specified.
- Handhold Panel:** Solid color Permalene®, color specified.
- Handrail:** Formed from 1.125" O.D. 11 GA (.120") galvanized steel tubing. Finish: TenderTuff, color specified.
- Footer:** Weldment comprised of 1.660" O.D. RS-20 (.085" - .095") galvanized steel tubing and 1/4" x 2" zinc plated steel strap. Finish: ProShield®, color specified.
- Spacer Tube:** Made from 6061-T6 aluminum 7/8" O.D. x 1 11/16". Finish: ProShield, color specified.
- Offset Hanger Clamp Assembly:** Cast aluminum. Finish: ProShield, color specified.
- Fasteners:** Primary fasteners shall be socketed and pinned tamperproof in design, stainless steel (SST) per ASTM F 879 unless otherwise indicated (see specific product installation/specifications).

- Installation Time:** SM - Approx. 1 1/4 man hours
 DB - Approx. 2 man hours
- Concrete Req.:** Approx. 1.4 cu. ft.
- Weight:** 32" Step Ladder (SM) - 90 lbs.
 32" Step Ladder (DB) - 100 lbs.
 40" Step Ladder (SM) - 106 lbs.
 40" Step Ladder (DB) - 116 lbs.
 56" Step Ladder (SM) - 142 lbs.
 56" Step Ladder (DB) - 152 lbs.
 72" Step Ladder (SM) - 185 lbs.
 72" Step Ladder (DB) - 195 lbs.
- Fall Height:** Deck Height

Installation Instructions

- (Direct Bury)** Dig footing holes spaced as shown. Attach support to step ladder using 3/8" x 7/8" BHCS w/pin and 3/8" standard hex nuts with 3/8" SAE flat washers.
- (Surface Mount 72" Step Ladder Only)** Attach support to step ladder using 3/8" x 7/8" BHCS w/pin and 3/8" standard hex nuts with 3/8" SAE flat washers.
- Attach offset hanger clamp assemblies to posts at height shown. Using 5" half clamps and 3/8" x 1 1/8" BHCS w/pin with 3/8" tee nuts. Refer To The Typical Offset Hanger Clamp Spec Sheet.
- Attach handhold panels to offset hanger clamp assemblies using 3/8" x 3 3/4" BHCS w/pin, spacer tubes and 3/8" flange nuts w/pin. See Panel Attachment Detail.
- Attach step ladder to deck using 3/8" x 7/8" BHCS w/pin with 3/8" SAE flat washers and 3/8" standard hex nuts with 3/8" SAE flat washers, as shown.
- Attach handhold panels to the face of the deck using 3/8" x 7/8" BHCS w/pin with 3/8" SAE flat washers and 3/8" flange nuts w/pin, as shown.
- Attach handrails to sides of step ladder using 3/8" x 7/8" BHCS w/pin with 3/8" SAE flat washers.
- Using a 7/16" drill bit, drill out the lower 1/8" pilot hole in each handhold panel for attaching handrails.
- Attach handrails to handhold panels using 3/8" x 1 3/8" BHCS w/pin, as shown.
- (Direct Bury)** With step ladder plumb, pour concrete footings. Allow concrete footings to cure a minimum of 72 hours before users are allowed to play on the structure.
- (Surface Mount)** Mark anchor bolt locations on concrete slab through holes in base of step ladder. Remove step ladder and drill 3/8" x 3" deep holes on marks into concrete using 3/8" masonry bit and hammer drill. Tap expansion anchors into drilled holes. Reposition step ladder and reattach to face of deck following step #4. Fasten base of step to expansion anchors using 3/8" standard hex nuts with 3/8" SAE flat washers.
- Install protective surfacing before users are allowed to play on the structure.

**DETAIL
 STEP TO DECK**

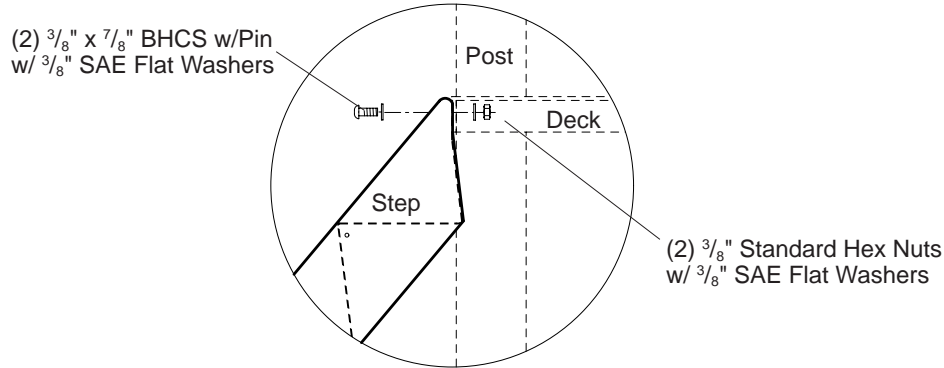

PLAN VIEW/FOOTING LAYOUTS

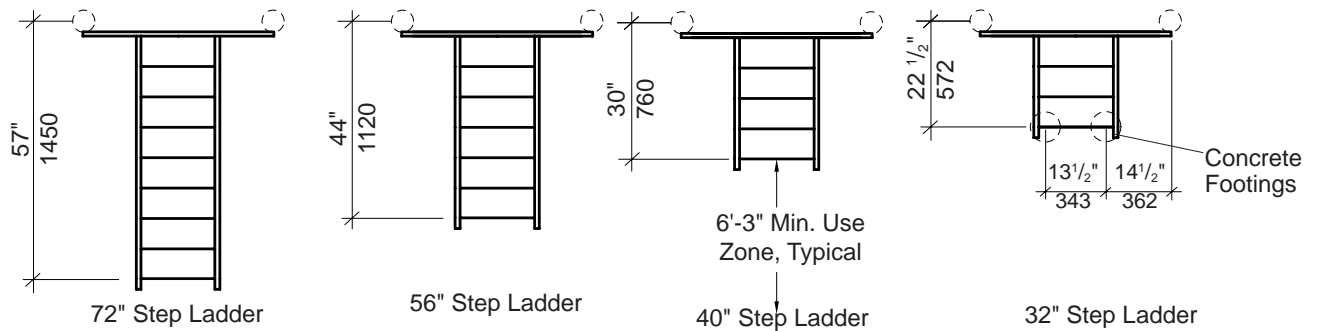

NOTE:
 Dimensions Are From Center Of Post To Center Of Footer

**DETAIL
 DIRECT BURY**

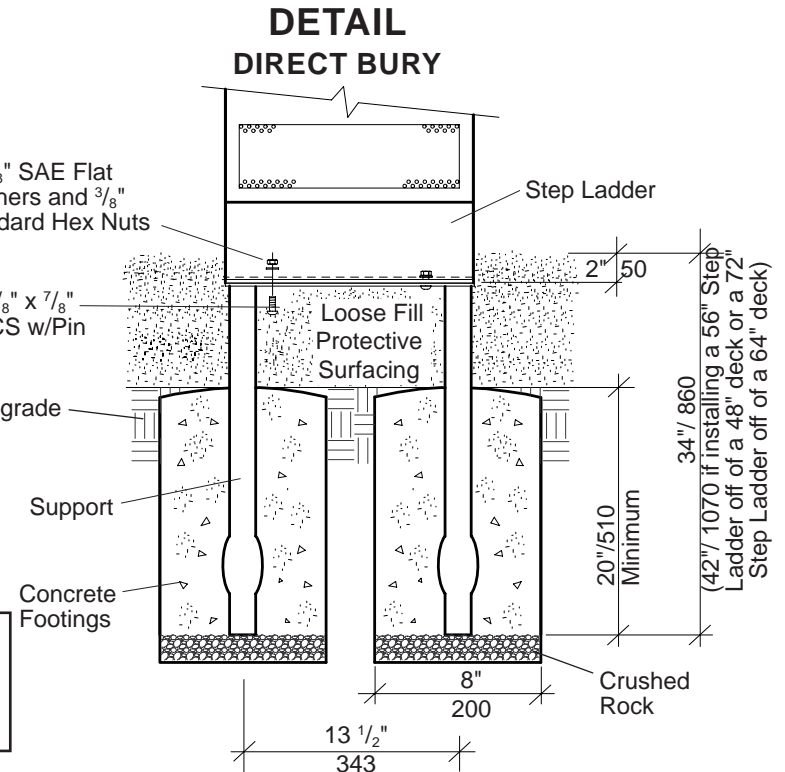
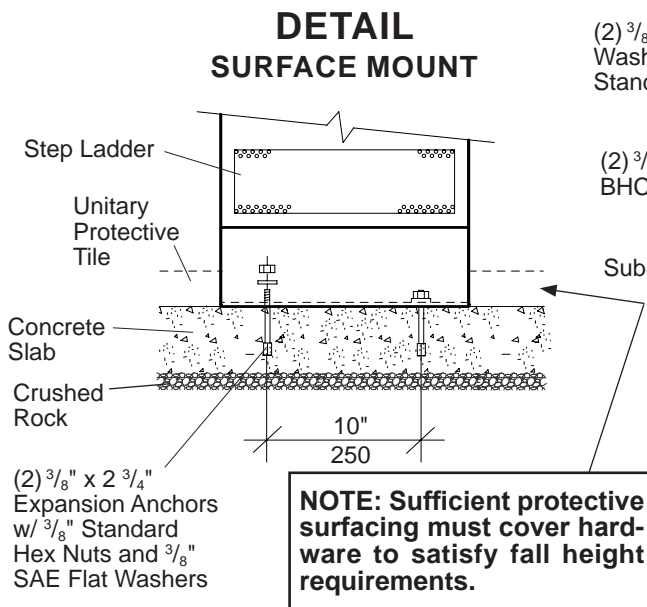

**PLAN VIEW
FOOTING PLAN**

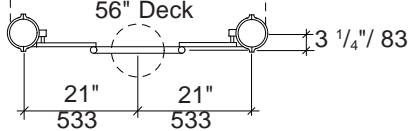

**DETAIL
PANEL ATTACHMENT**

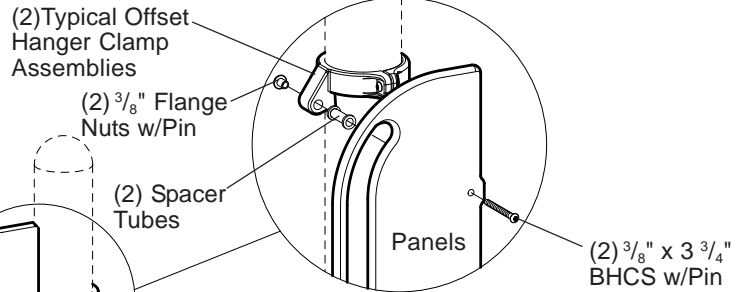

**DETAIL
Surface Mount (64" Deck)**

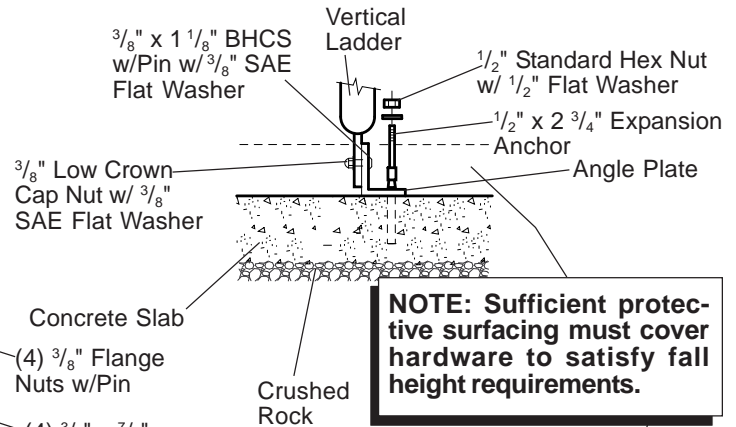

NOTE: Sufficient protective surfacing must cover hardware to satisfy fall height requirements.

**DETAIL
Surface Mount (72" Deck)**

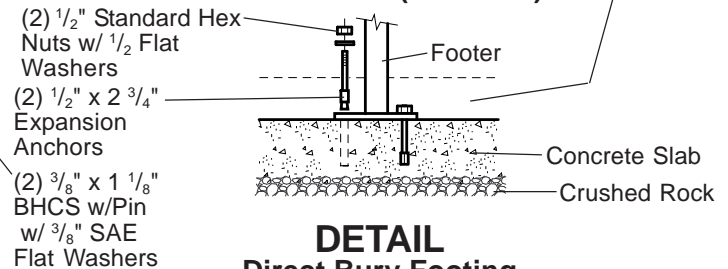

**DETAIL
Direct Bury Footing**

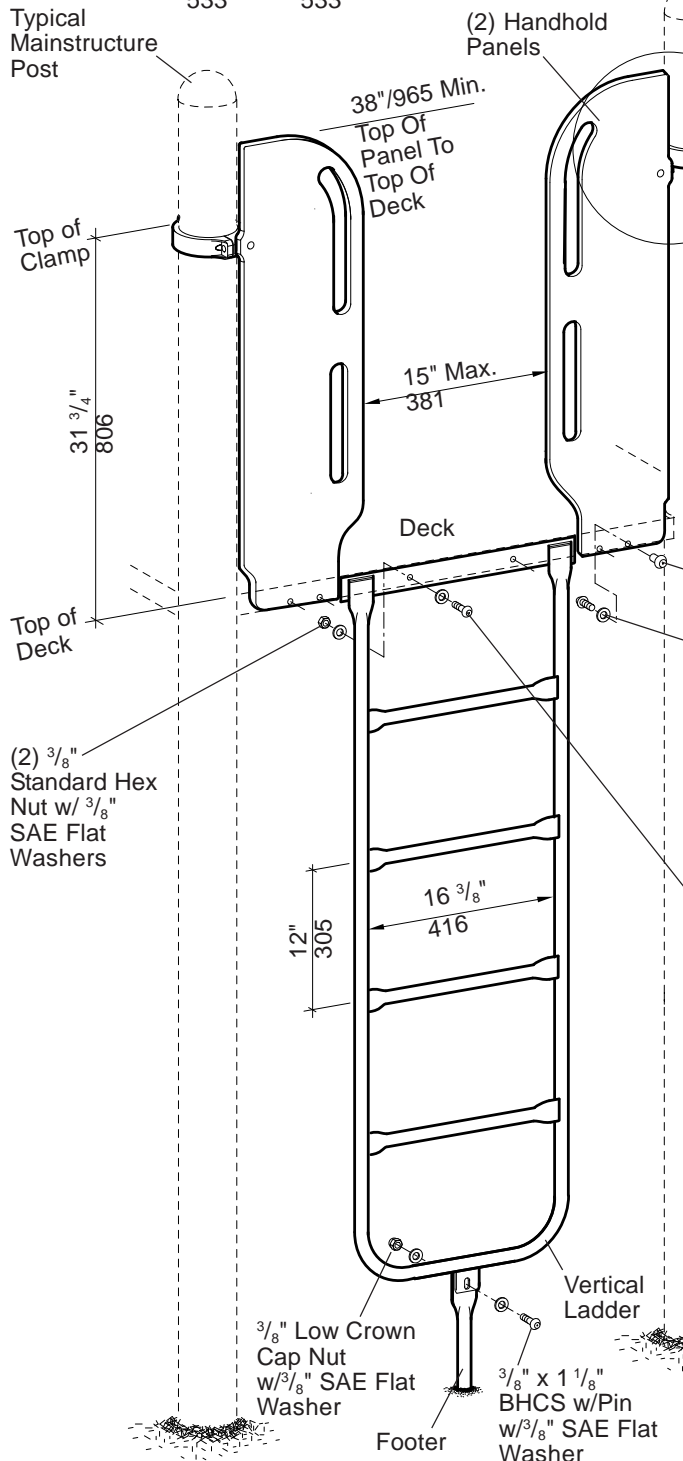
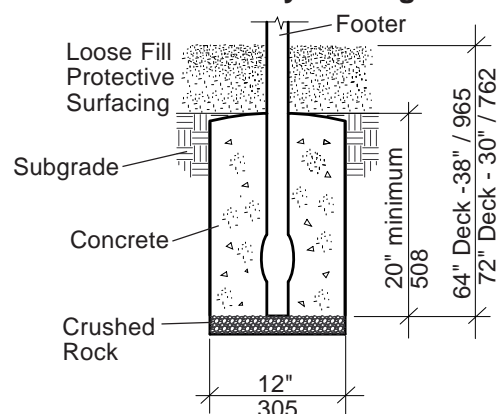

PlayBooster® 116249 Vertical Ladder, 64" - 72" Decks

Parts List

Part#	Description	Qty.
115779	Vertical Ladder, 64"/72", Specify Color	1
139563	Handhold Panel, Specify Color	2
180703	Footer (DB), Specify Color	1
180705	Footer (SM), Specify Color	1
180702	Angle Plate (SM), Specify Color	1
105327	5" Half Clamp, Specify Color	2
113729	Offset Hanger Clamp, Specify Color	2
113468	Spacer Tube, Specify Color	2
190270	Vertical Ladder (Tenderdeck) Hardware Pkg ...	1
124460	3/8" x 3 3/4" BHCS w/Pin, SST	2
100196	3/8" x 7/8" BHCS w/Pin, SST	4
100198	3/8" x 1 1/8" BHCS w/Pin, SST	7
100327	3/8" Standard Hex Nut, SST	2
100349	3/8" Low Crown Cap Nut, SST	1
100351	3/8" Tee Nut, SST	4
100353	3/8" Flange Nut w/Pin, SST	6
100365	3/8" SAE Flat Washer, SST	10
111392	2 Hole (SM) Hardware Package	1
100266	1/2" x 2 3/4" Expansion Anchor	2
100322	1/2" Standard Hex Nut, SST	2
100363	1/2" Flat Washer, SST	2
116432	1 Hole (SM) Hardware Package	1
100266	1/2" x 2 3/4" Expansion Anchor	1
100322	1/2" Standard Hex Nut, SST	1
100363	1/2" Flat Washer, SST	1

DB = Direct Bury
SM = Surface Mount

Specifications

Vertical Ladder:	Weldment comprised of 1.125" O.D. 11 GA (.120") steel tubing, 1.029" O.D. RS-20 (.070" - .080") and 3/16" x 2" wide steel flat plates. Finish: TenderTuff®, color specified.
Footer:	Fabricated from 1.315" O.D. RS-20 (.080" - .090") galvanized steel tubing. Finish: ProShield®, color specified.
Handhold Panel:	Solid color Permalene®, color specified.
Spacer Tube:	Made from 6061-T6 aluminum 7/8" O.D. x 1 1/16". Finish: ProShield, color specified.
Offset Hanger Clamp Assembly:	Cast aluminum. Finish: ProShield, color specified.
Fasteners:	Primary fasteners shall be socketed and pinned tamperproof in design, stainless steel (SST) per ASTM F 879 unless otherwise indicated (see specific product installation/specifications).
Installation Time:	DB - Approx. 1 1/2 man hour SM - Approx. 1 man hour
Concrete Req.:	1.3 cu. ft.
Weight:	DB, 64"/72" - 51 lbs. SM, 64" - 54 lbs. SM, 72" - 56 lbs.
Fall Height:	Deck Height

Installation Instructions

Direct Bury

- 1) Dig footing to depth and spacing, as shown.
- 2) Attach footer to ladder, using a 3/8" x 1 1/8" BHCS w/pin with 3/8" SAE flat washer and a 3/8" low crown cap nut with 3/8" SAE flat washer, as shown.
- 3) Attach ladder to deck, using 3/8" x 1 1/8" BHCS w/pin with 3/8" SAE flat washers and 3/8" standard hex nuts with 3/8" SAE flat washers, as shown.
- 4) Attach handhold panel to the face of the deck, using 3/8" x 7/8" BHCS w/pin with 3/8" SAE flat washers and 3/8" flange nuts w/pin, as shown. **NOTE: Be sure handhold panels are snug to vertical ladder.**
- 5) Attach offset hanger clamps to posts at height shown, using 5" half clamps and 3/8" x 1 1/8" BHCS w/pin with 3/8" tee nuts. Refer To The Typical Offset Hanger Clamp Spec Sheet.
- 6) Attach panels to offset hanger clamp assemblies, using 3/8" x 3 3/4" BHCS w/pin, spacer tubes and 3/8" flange nuts w/pin. See Panel Attachment Detail.
- 7) With ladder plumb, pour concrete footing. Allow concrete footing to cure a minimum of 72 hours before users are allowed to play on the structure.
- 8) Install protective surfacing before users are allowed to play on the structure.

Surface Mount

- 1) Attach footer to ladder, using a 3/8" x 1 1/8" BHCS w/pin with 3/8" SAE flat washer and a 3/8" low crown cap nut with 3/8" SAE flat washer, as shown. **NOTE: The Footer (SM) is used for the 72" deck height, and the Angle Plate (SM) is used for the 64" deck height.**
- 2) Attach ladder to deck, using 3/8" x 1 1/8" BHCS w/pin with 3/8" SAE flat washers and 3/8" standard hex nuts with 3/8" SAE flat washers, as shown.
- 3) Attach handhold panel to the face of the deck, using 3/8" x 7/8" BHCS w/pin with 3/8" SAE flat washers and 3/8" flange nuts w/pin, as shown. **NOTE: Be sure handhold panels are snug to vertical ladder.**
- 4) Attach offset hanger clamps to posts at height shown, using 5" half clamps and 3/8" x 1 1/8" BHCS w/pin with 3/8" tee nuts. Refer To The Typical Offset Hanger Clamp Spec Sheet.
- 5) Attach panel to offset hanger clamp assemblies, using 3/8" x 3 3/4" BHCS w/pin, spacer tubes and 3/8" flange nuts w/pin. See Panel Attachment Detail.
- 6) Using a 1/2" hammer drill and 1/2" masonry bit, drill anchor bolt holes into concrete slab 3" deep through holes in footer plate or angle plate, as shown.
- 7) Tap expansion anchors into holes and fasten, using 1/2" flat washers and 1/2" standard hex nuts, as shown.
- 8) Install protective surfacing before users are allowed to play on the structure.

Off 32" Deck (DB) Only
Off 40" Deck (Shown)
Off 48" Deck
Off 56" Deck
Off 64" Deck
Off 72" Deck

PLAN VIEW/FOOTING LAYOUT

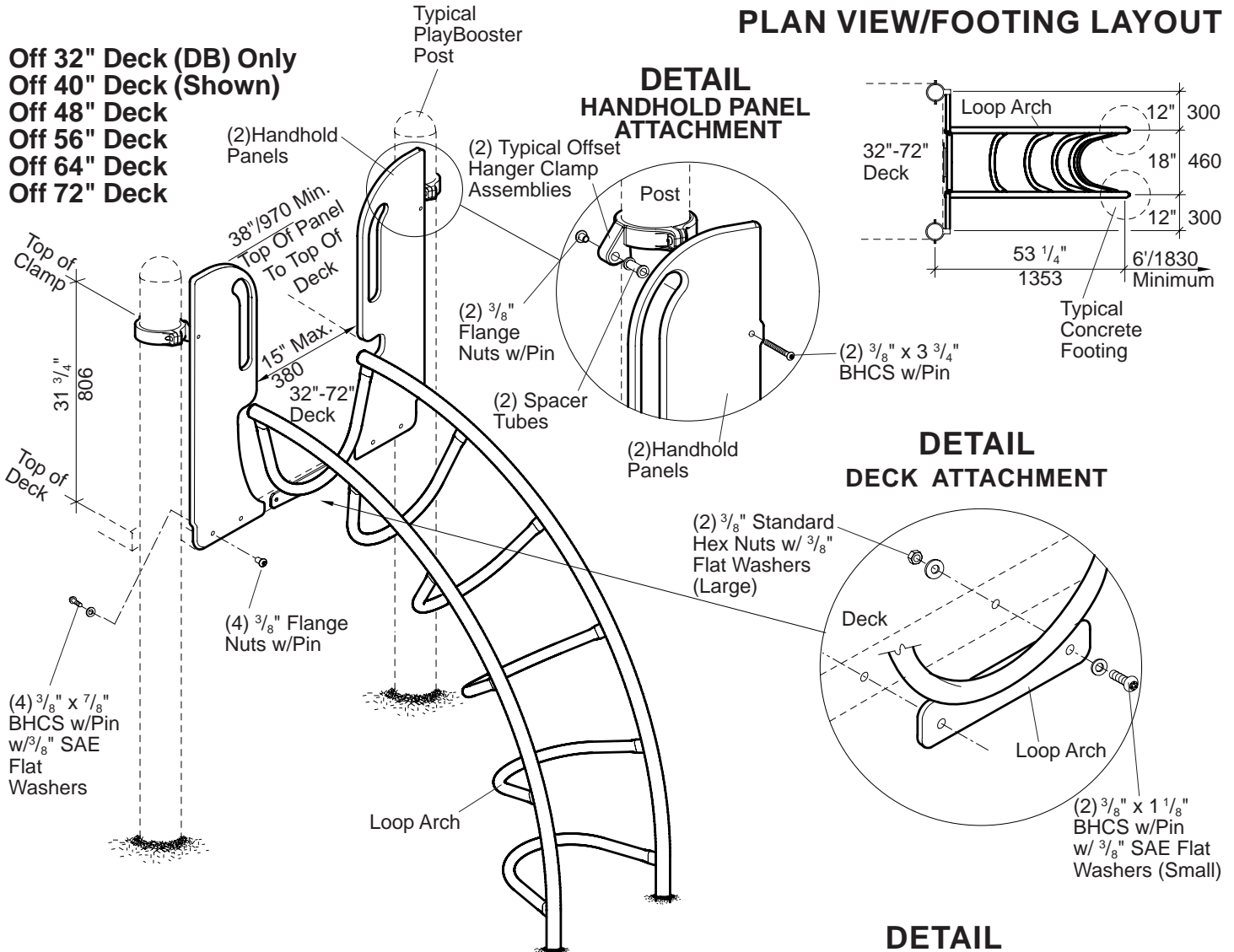

DETAIL HANDHOLD PANEL ATTACHMENT

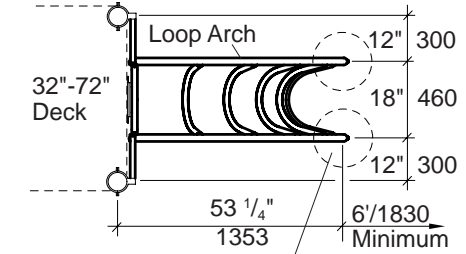
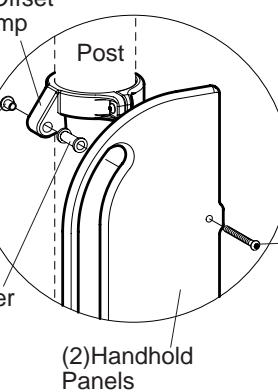

DETAIL DECK ATTACHMENT

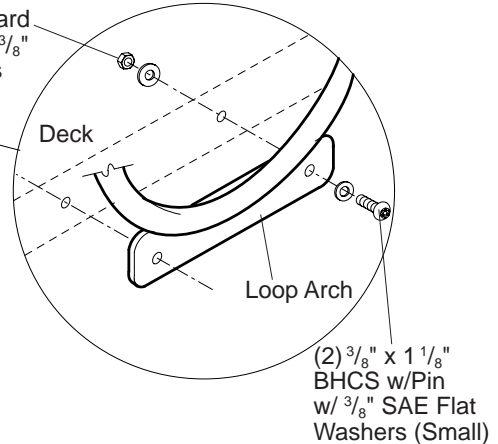

DETAIL SURFACE MOUNT

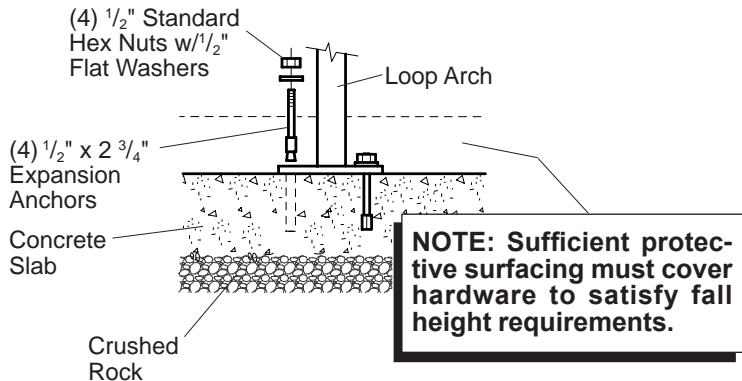

NOTE: Sufficient protective surfacing must cover hardware to satisfy fall height requirements.

DETAIL DIRECT BURY

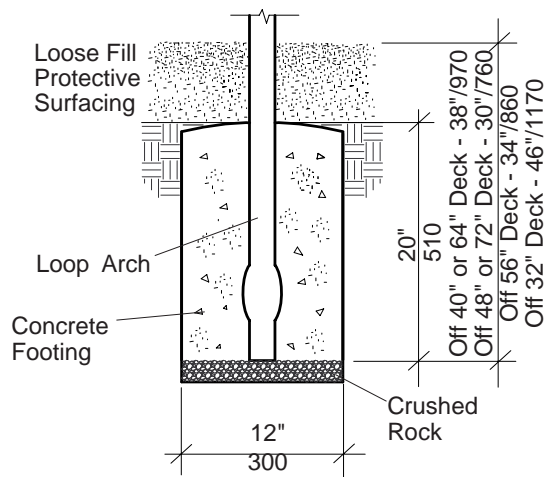

Parts List

Part#	Description	Qty.
139561	Handhold Panel, Specify Color	2
111595	32", 40" & 48" Loop Arch (DB), Specify Color	1
111596	56" Loop Arch (DB), Specify Color.....	1
111597	64" & 72" Loop Arch (DB), Specify Color.....	1
111598	40" Loop Arch (SM), Specify Color	1
111599	48" Loop Arch (SM), Specify Color	1
111600	56" Loop Arch (SM), Specify Color	1
111601	64" Loop Arch (SM), Specify Color	1
111602	72" Loop Arch (SM), Specify Color	1
105327	5" Half Clamp, Specify Clamp.....	2
113729	Offset Hanger Clamp, Specify Color	2
113468	Spacer Tube, Specify Color.....	2
211597	Loop Arch (Tenderdeck) Hardware Package	1
100198	3/8" x 1 1/8" BHCS w/Pin, SST.....	2
100327	3/8" Standard Hex Nut, SST	2
100362	3/8" Flat Washer, SST	2
100365	3/8" SAE Flat Washer, SST.....	2
139551	Handhold (Tenderdeck) Hardware Package	1
124460	3/8" x 3 3/4" BHCS w/Pin, SST	2
100196	3/8" x 7/8" BHCS w/Pin, SST	4
100198	3/8" x 1 1/8" BHCS w/Pin, SST	4
100351	3/8" Tee Nut, SST.....	4
100353	3/8" Flange Nut w/Pin, SST.....	6
100365	3/8" SAE Flat Washer, SST.....	4
121348	4 Hole (SM) Hardware Package	1
100266	1/2" x 2 3/4" Expansion Anchor	4
100322	1/2" Standard Hex Nut, SST	4
100363	1/2" Flat Washer, SST	4

DB = Direct Bury
SM = Surface Mount

Specifications

Loop Arch:	Weldment comprised of 1.660 O.D. RS-20 (.085" - .095") galvanized steel tubing, 1.315" O.D. RS-20 (.080" - .090") galvanized steel tubing and 1/4" flat steel. Finish: ProShield®, color specified.
Handhold Panel:	Solid color Permalene®, color specified.
Spacer Tube:	Made from 6061-T6 aluminum 7/8" O.D. x 1 11/16". Finish: ProShield, color specified.
Offset Hanger Clamp Assembly:	Cast aluminum. Finish: ProShield, color specified.
Fasteners:	Primary fasteners shall be socketed and pinned tamperproof in design, stainless steel (SST) per ASTM F 879 unless otherwise indicated (see specific product installation/specifications).
Installation Time:	SM - Approx. 1 1/2 man hours DB - Approx. 2 1/2 man hours
Concrete Req.:	Approx. 2.6 cu. ft.
Weight:	32", 40" & 48" - 85 lbs. 56" - 91 lbs. 64" & 72" - 97 lbs.
Fall Height:	Deck Height

Installation Instructions

- 1) **(Direct Bury)** Dig footing holes spaced as shown.
 - 2) Attach loop arch to deck using 3/8" x 1 1/8" BHCS w/pin with 3/8" SAE flat washers (small) and 3/8" standard hex nuts with 3/8" flat washers (large).
 - 3) Attach handhold panels to the face of the deck using 3/8" x 7/8" BHCS w/pin with 3/8" SAE flat washers and 3/8" flange nuts w/pin.
 - 4) Attach offset hanger clamps to posts at heights shown using 5" half clamps, 3/8" x 1 1/8" BHCS w/pin and 3/8" tee nuts. Refer to the Typical Offset Hanger Clamp Spec Sheet.
 - 5) Attach handhold panels to the offset hanger clamp assemblies using 3/8" x 3 3/4" BHCS w/pin, spacer tubes and 3/8" flange nuts w/pin. Refer to the Handhold Panel Attachment Detail.
 - 6) **(Direct Bury)** With loop arch in final position, pour concrete footings. Allow concrete footings to cure a minimum of 72 hours before users are allowed to play on the structure.
- (Surface Mount)** Mark anchor bolt locations on concrete slab through holes in anchor plate and remove loop arch. Drill 1/2" x 3" deep holes on marks into concrete using hammer drill and 1/2" masonry bit. Tap expansion anchors into drilled holes. Reposition loop arch and reattach to the face of the deck following step 2. Fasten anchor plates to expansion anchors using 1/2" standard hex nuts with 1/2" flat washers.
- 7) Install protective surfacing before users are allowed to play on the structure.

**PLAN VIEW/
FOOTING LAYOUT**

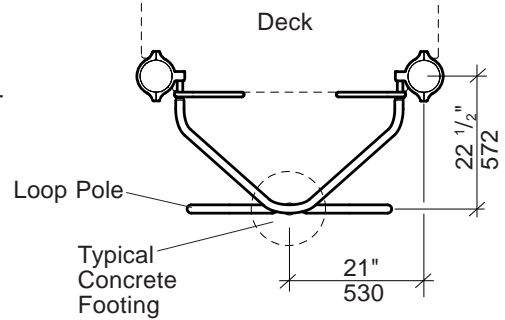

**DETAIL
HANDHOLD PANEL ATTACHMENT**

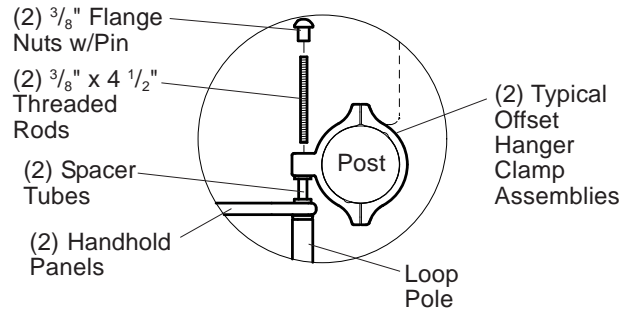

**DETAIL
SURFACE MOUNT**

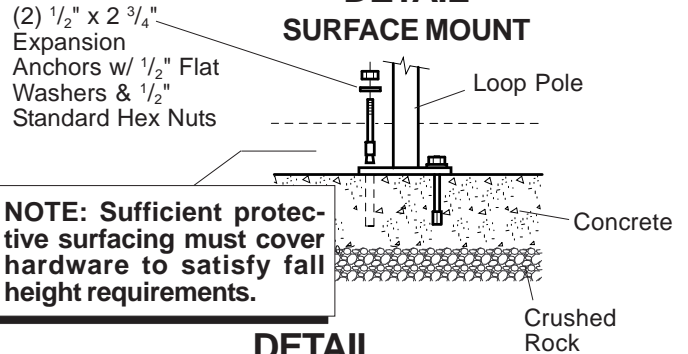

**DETAIL
DIRECT BURY**

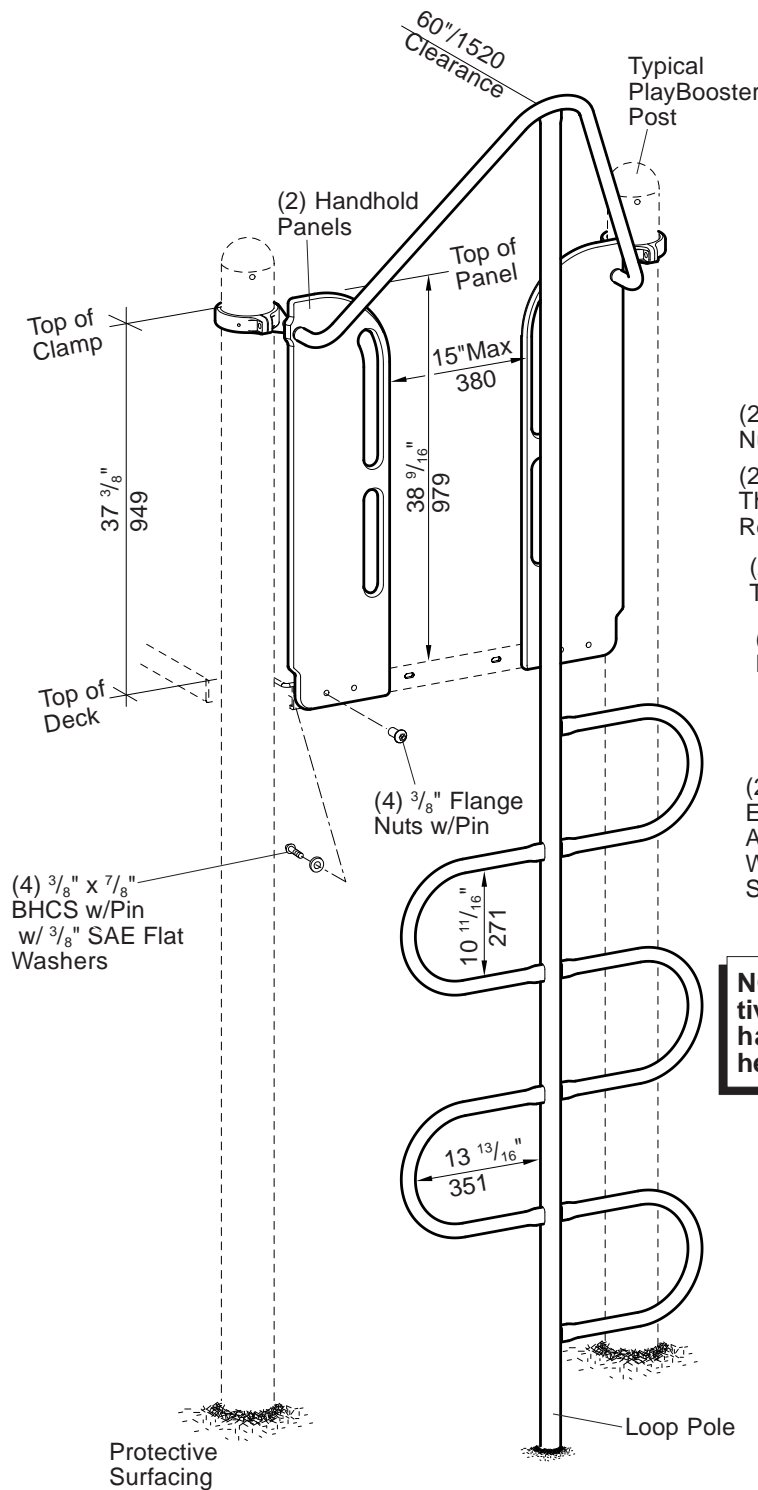
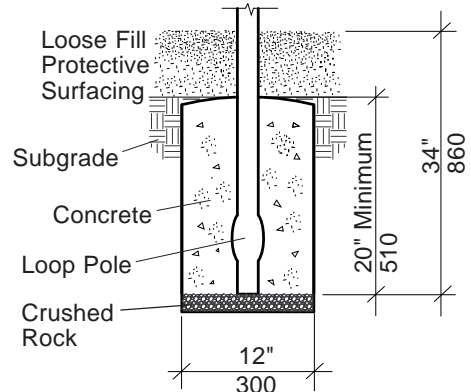

72" Deck Height Shown

PlayBooster®

148434 Loop Poles, 32"-72"

Parts List

Part#	Description	Qty.
147954	Handhold Panel, Specify Color	2
105327	5" Half Clamp, Specify Color	2
113729	Offset Hanger Clamp, Specify Color	2
147975	Loop Pole, 32" Deck (DB), Specify Color	1
147976	Loop Pole, 40" Deck (DB), Specify Color	1
147977	Loop Pole, 48" Deck (DB), Specify Color	1
147978	Loop Pole, 56" Deck (DB), Specify Color	1
147979	Loop Pole, 64" Deck (DB), Specify Color	1
147980	Loop Pole, 72" Deck (DB), Specify Color	1
147981	Loop Pole, 32" Deck (SM), Specify Color	1
147982	Loop Pole, 40" Deck (SM), Specify Color	1
147983	Loop Pole, 48" Deck (SM), Specify Color	1
147984	Loop Pole, 56" Deck (SM), Specify Color	1
147985	Loop Pole, 64" Deck (SM), Specify Color	1
147986	Loop Pole, 72" Deck (SM), Specify Color	1
113468	7/8" O.D. x 1 11/16" Spacer Tube, Specify Color	2
100610	1/4" x 5/8" Drive Rivet, AL/SST	2
148176	Pole Hardware Package	1
100196	3/8" x 7/8" BHCS w/Pin, SST	4
100198	3/8" x 1 1/8" BHCS w/Pin, SST	4
100351	3/8" Tee Nut, SST	4
100353	3/8" Flange Nut w/Pin, SST	6
100365	3/8" SAE Flat Washer, SST	4
148081	3/8" x 4 1/2" Threaded Rod, SST	2
111392	2-Hole (SM) Hardware Package	1
100266	1/2" x 2 3/4" Expansion Anchors	2
100322	1/2" Standard Hex Nut, SST	2
100363	1/2" Flat Washer, SST	2

DB = Direct Bury
SM = Surface Mount

Specifications

Loop Pole:	Weldment comprised of 1.900" O.D. RS-20 (.090" - .100") galvanized steel tubing, and 1.315" O.D. RS-20 (.080" - .090") galvanized steel tubing. Finish: ProShield®, color specified.
Handhold Panel:	Solid color Permalene®, color specified.
Spacer Tube:	Made from 6061-T6 aluminum 7/8" O.D. x 1 11/16". Finish: ProShield, color specified.
Clamps:	Cast aluminum. Finish: ProShield, color specified.
Fasteners:	Primary fasteners shall be socketed and pinned tamperproof in design, stainless steel (SST) per ASTM F 879 unless otherwise indicated (see specific product installation/specifications).
Installation Time:	SM - Approx. 1 1/2 man hours DB - Approx. 2 man hours
Concrete Req.:	Approx. 1.3 cu. ft.
Weight:	65 lbs. (32"-48" Deck) 76 lbs. (56"-72" Deck)
Fall Height:	Deck Height

Installation Instructions

- (Direct Bury)** Dig footing hole as shown. Refer to the Plan View/Footing Layout.
- Attach offset hanger clamps to posts at heights shown using 5" half clamps, 3/8" x 1 1/8" BHCS w/pin and 3/8" tee nuts. Refer to the Typical Offset Hanger Clamp Spec Sheet.
- Attach handhold panels to the face of the deck using 3/8" x 7/8" BHCS w/pin with 3/8" SAE flat washers and 3/8" flange nuts w/pin.
- Attach loop pole to handhold panels and offset hanger clamps using 3/8" flange nuts w/pin, 3/8" x 4 1/2" threaded rods and spacer tubes. Refer to the Handhold Panel Attachment Detail. **NOTE: Turn 3/8" x 4 1/2" threaded rod into 3/8" flange nut w/pin until it bottoms out, before attaching loop pole.**
- (Direct Bury)** With loop pole plumb, pour concrete footing. Allow concrete footing to cure a minimum of 72 hours before users are allowed to play on the structure.
(Surface Mount) Drill 1/2" x 3" deep holes through support plate using hammer drill and 1/2" masonry bit. Tap expansion anchors into drilled holes. Fasten support plates to expansion anchors using 1/2" standard hex nuts with 1/2" flat washers.
- Install protective surfacing before users are allowed to play on the structure.

NOTE: Decks and posts are sold separately.

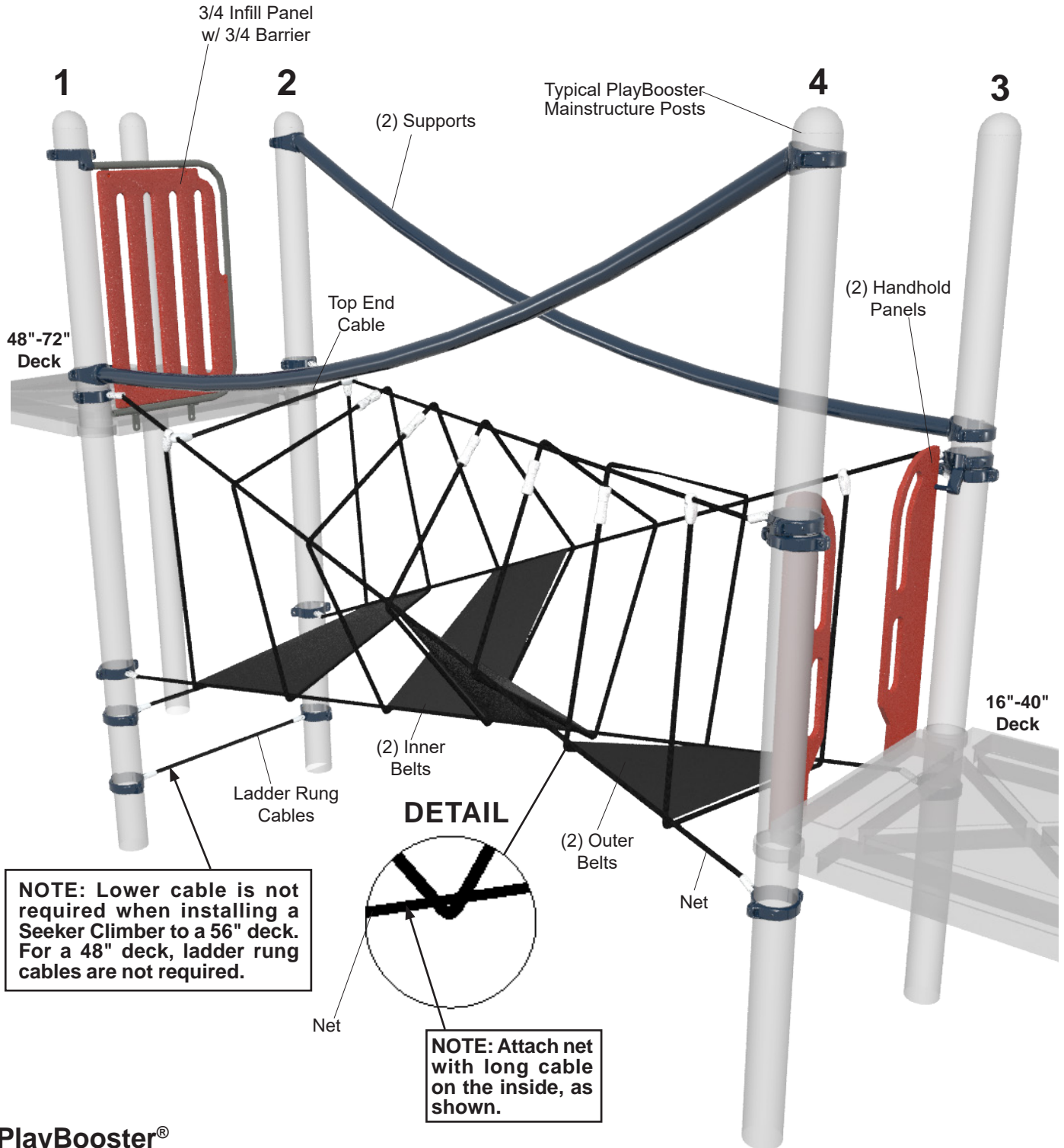

PlayBooster®

203845 Seeker Climber, 32" Dk Diff. w/Permalene Handholds

**DETAIL
HANDHOLD PANEL
ATTACHMENT**

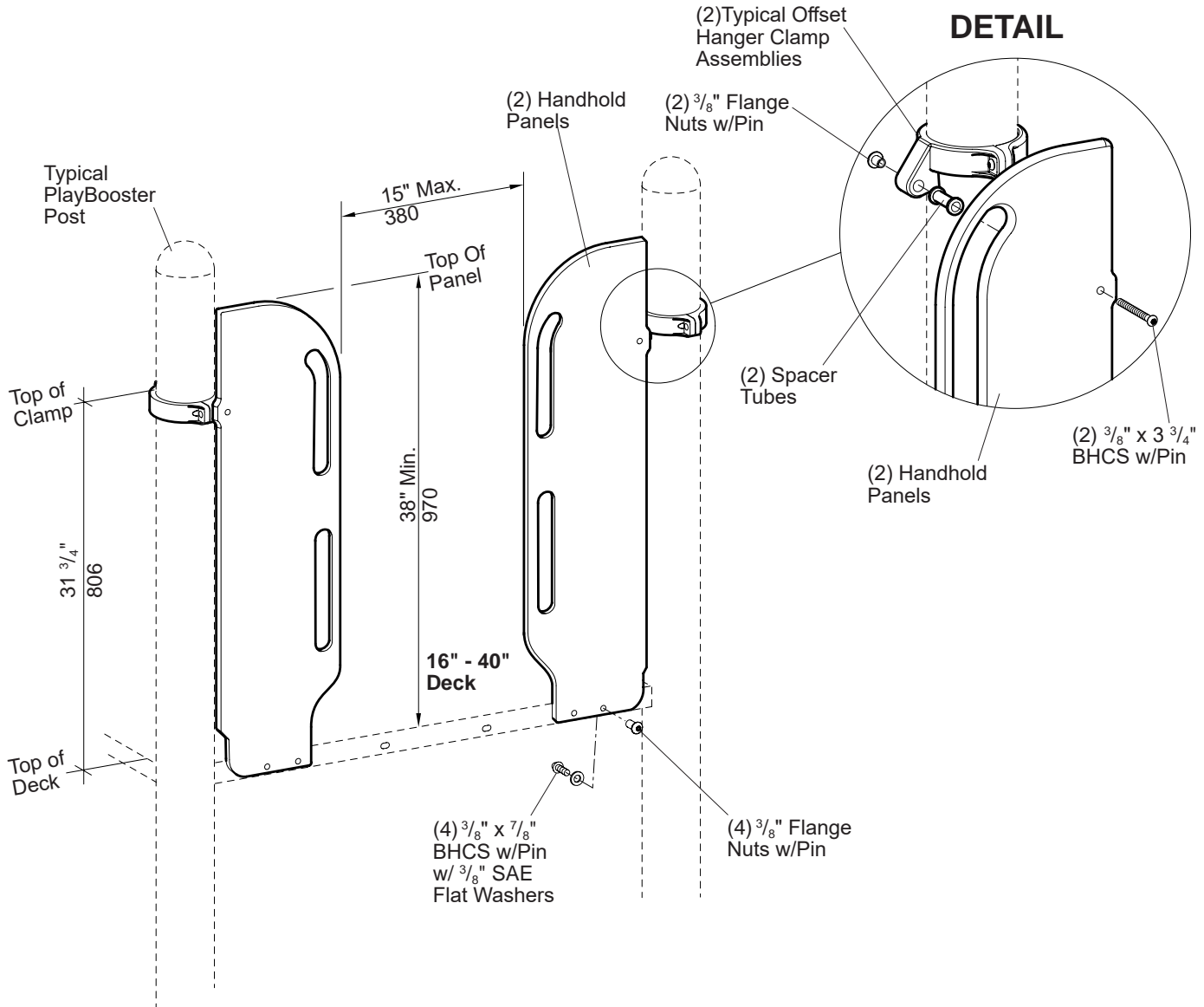

PlayBooster®

203845 Seeker Climber, 32" Dk Diff. w/Permalene Handholds

**DETAIL
BARRIER W/INFILL PANEL
ATTACHMENT**

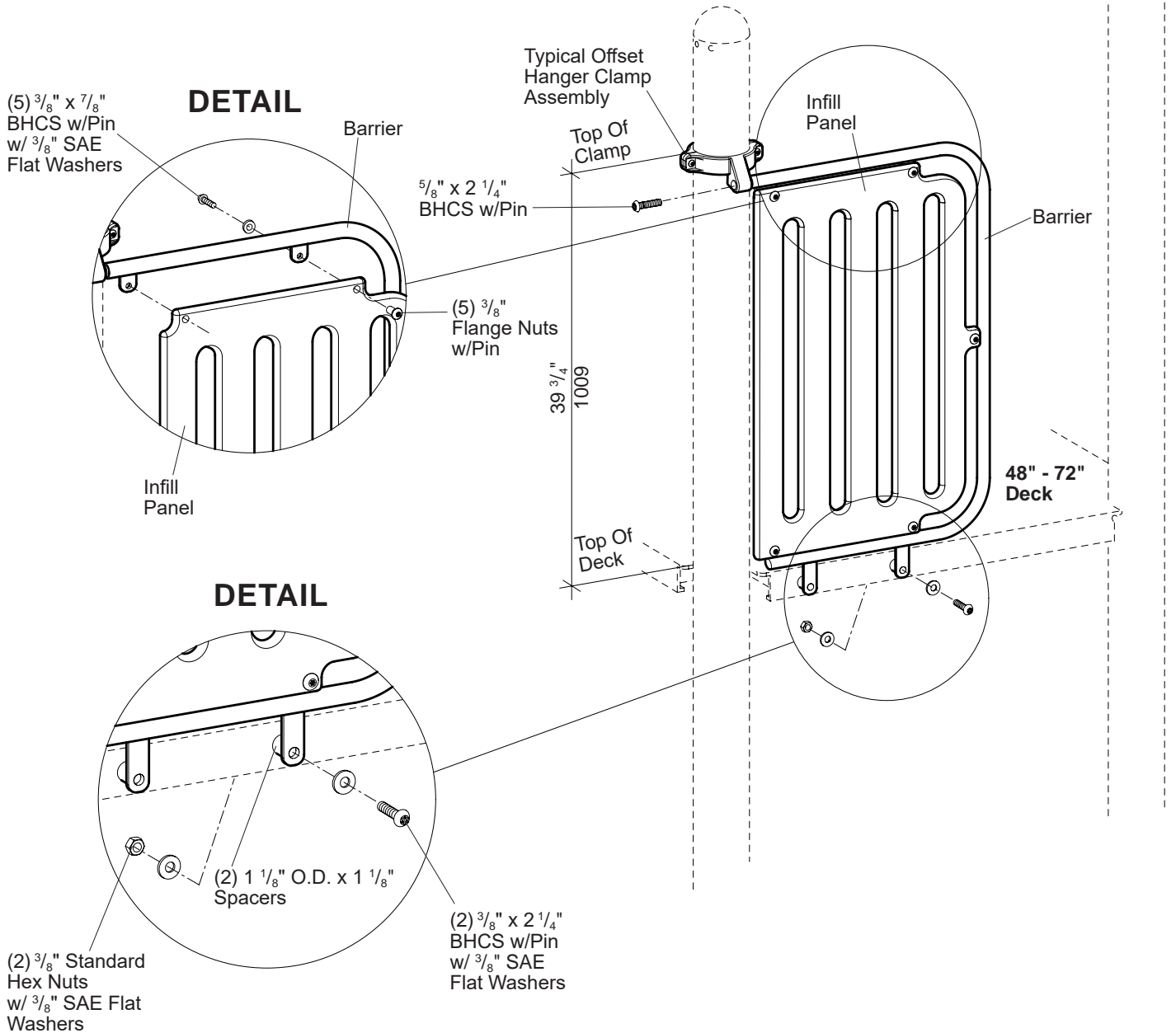

**DETAIL
SUPPORT ATTACHMENT**

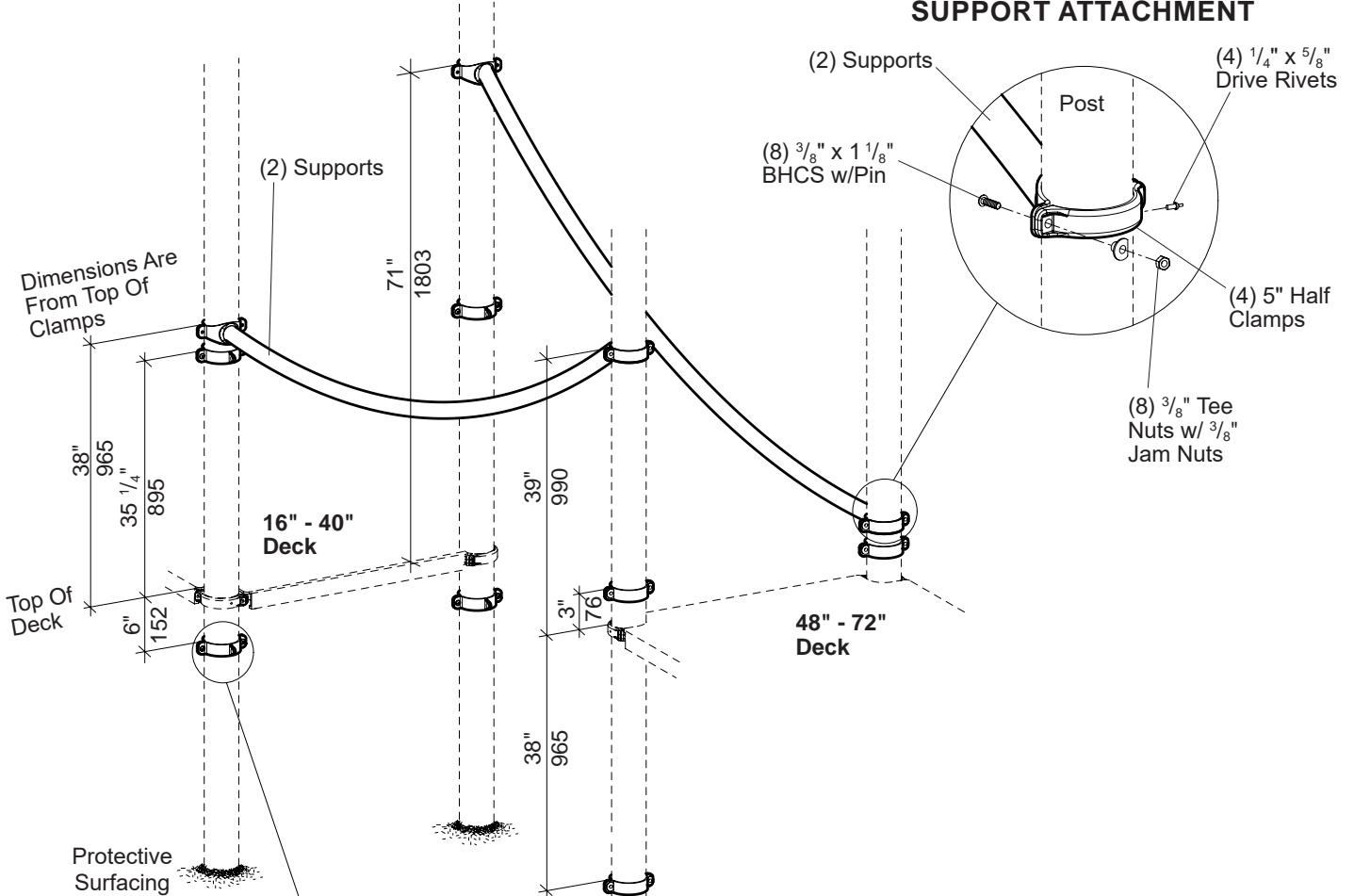

**DETAIL
NET ATTACHMENT**

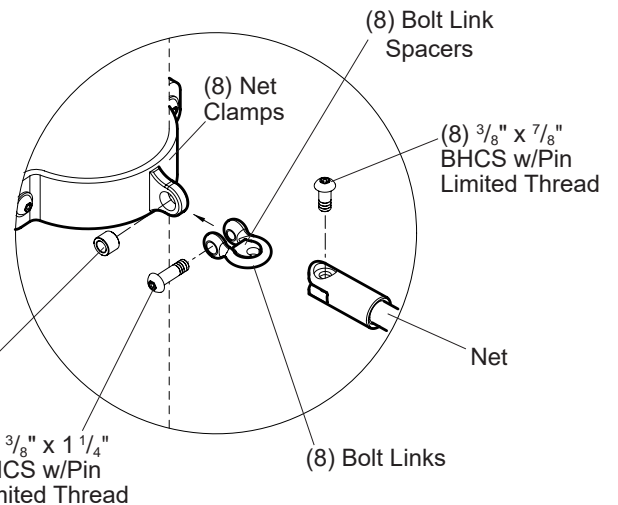

**DETAIL
NET CLAMP ATTACHMENT**

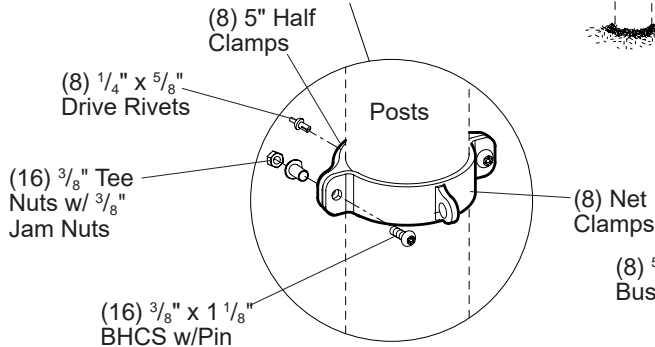

PlayBooster®

203845 Seeker Climber, 32" Dk Diff. w/Permalene Handholds

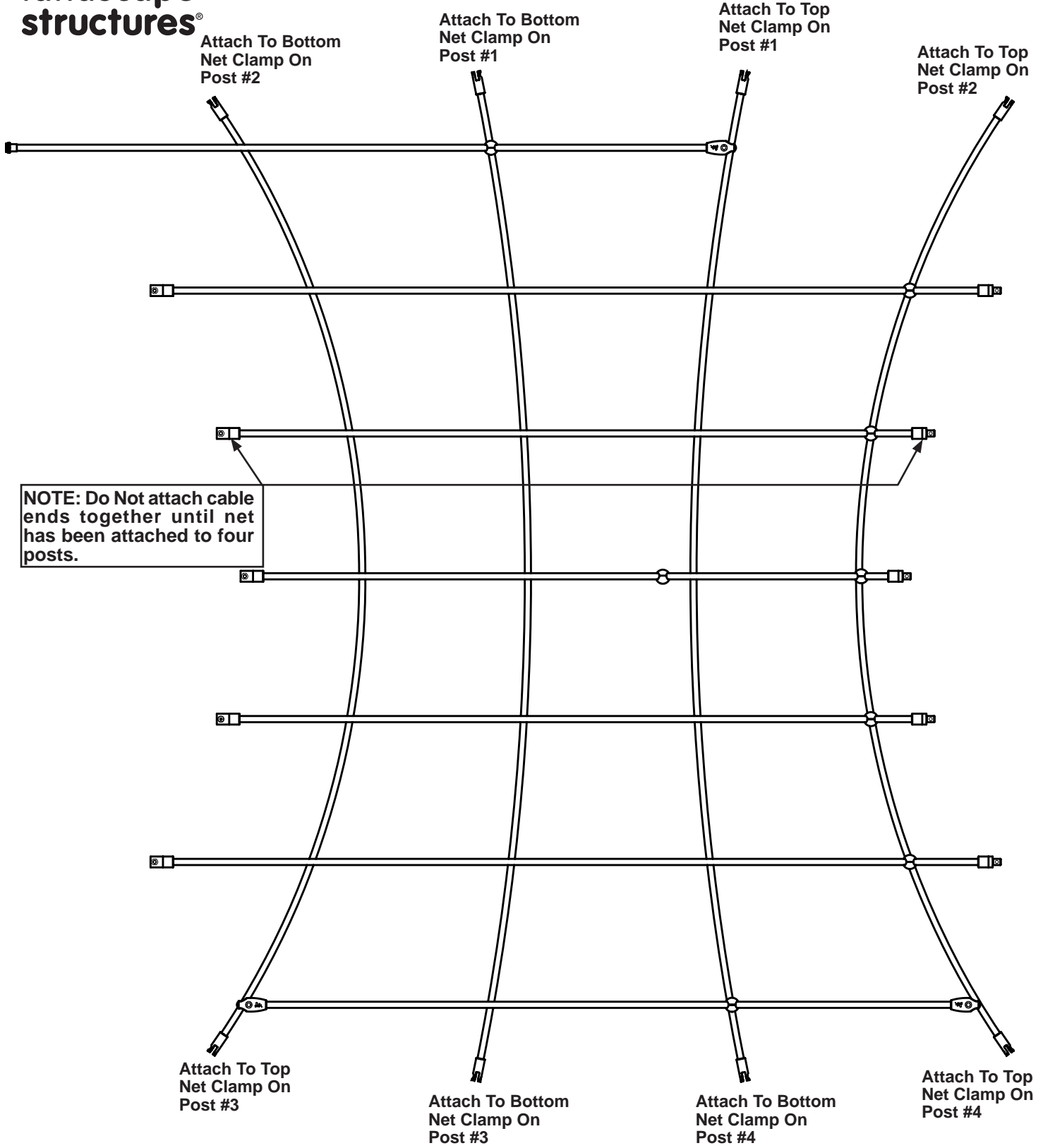

NOTE: Do Not attach cable ends together until net has been attached to four posts.

DETAIL
LADDER RUNG CABLE ATTACHMENT

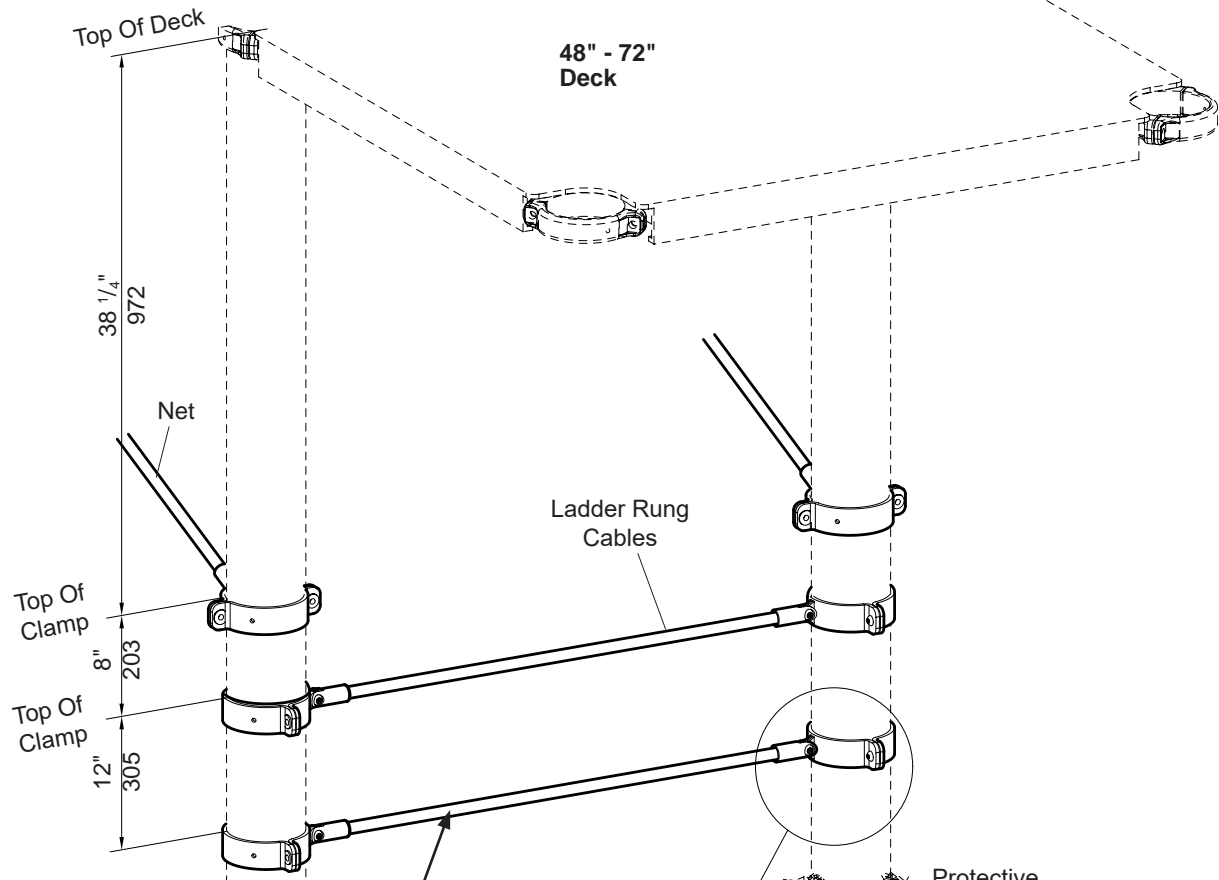

NOTE: Lower cable is not required when installing a Seeker Climber to a 56\"/>

DETAIL

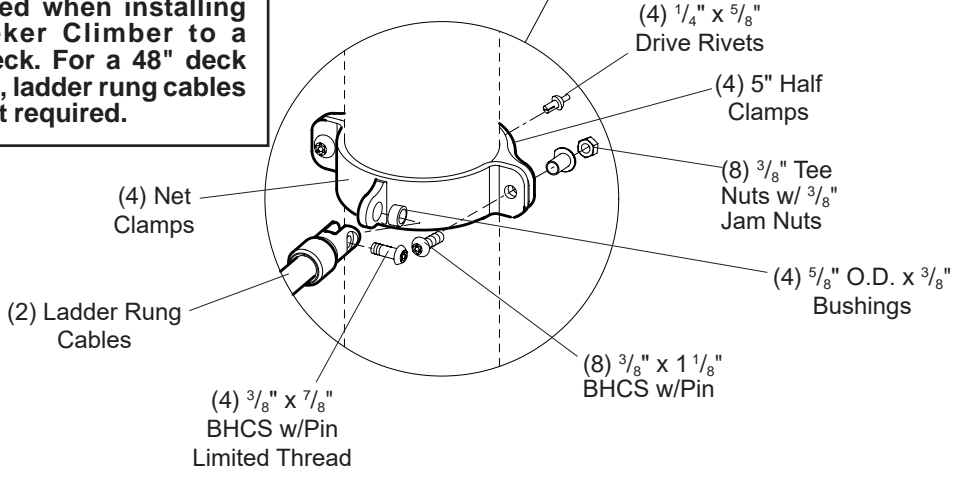

PlayBooster®

203845 Seeker Climber, 32\"/>

**DETAIL
TOP END CABLE
ATTACHMENT**

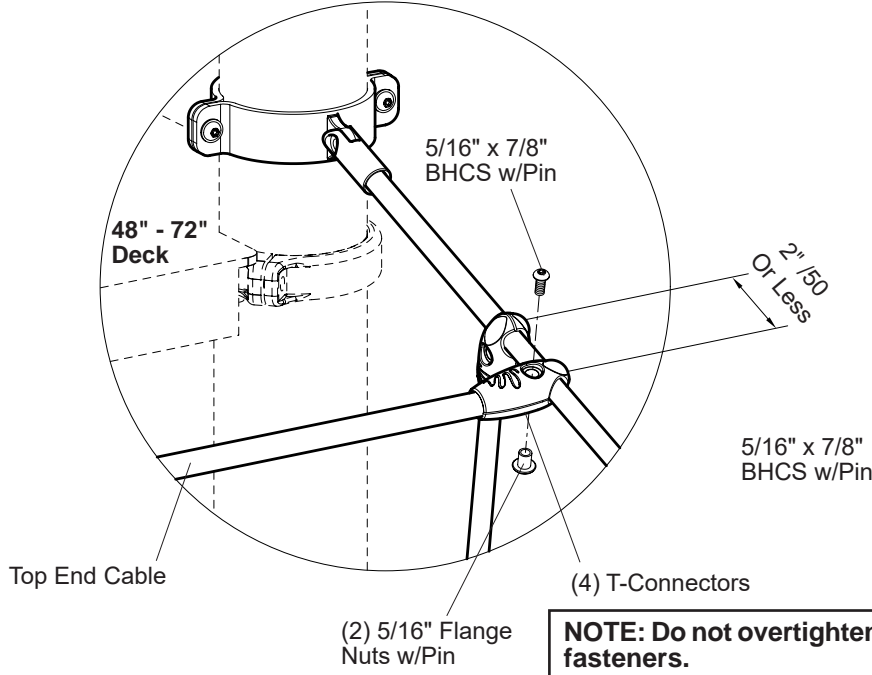

**DETAIL
CABLE END
ATTACHMENT**

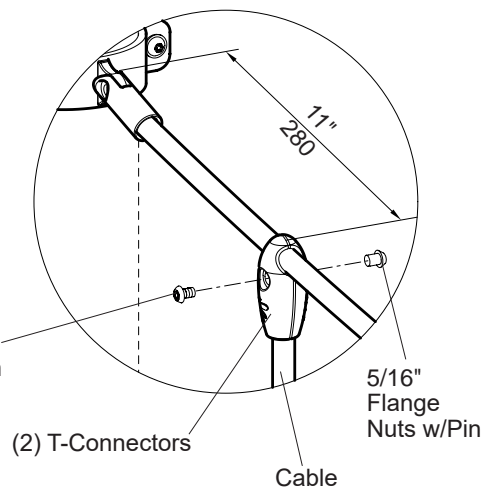

**DETAIL
BELT ATTACHMENT**

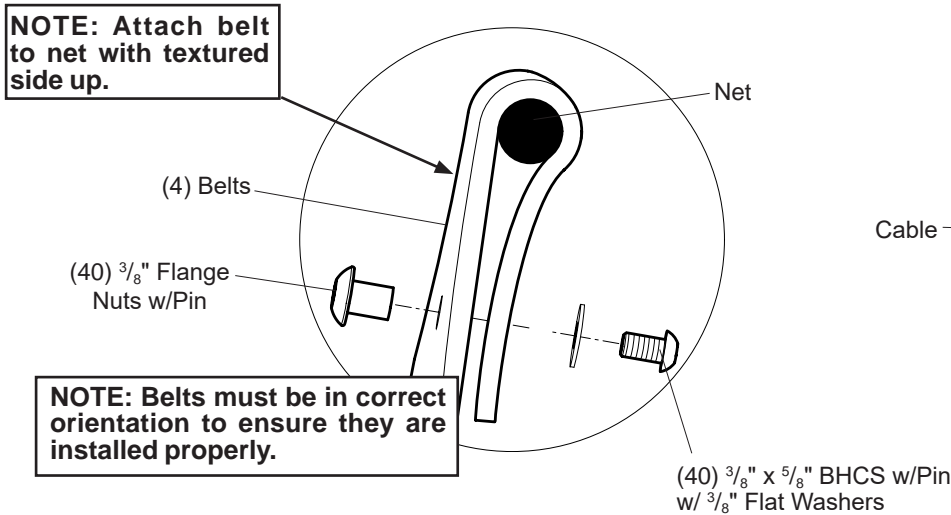

**DETAIL
CABLE TO CABLE
CONNECTION**

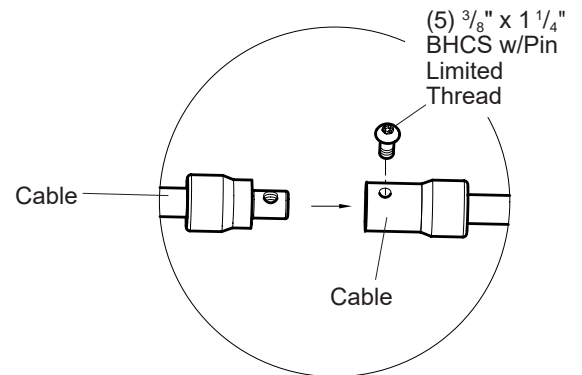

Part#	Description	Qty.
190908	Support, Specify Color.....	2
203696	Net, Black.....	1
228424	Inner Belt, Black.....	2
228422	Outer Belt, Black.....	2
161898	Net Clamp, Specify Color.....	*
100610	1/4" x 5/8" Drive Rivet, AL/SST.....	*
105327	5" Half Clamp, Specify Color.....	*
113468	7/8" O.D. x 1 11/16" Spacer Tube, AL., Specify Color.....	2
113729	5" Offset Hanger Clamp, Specify Color.....	3
139563	Handhold Panel, Specify Color.....	2
170930	Barrier, Specify Color.....	1
151072	1 1/8" O.D. x 1 1/8" Spacer, Specify Color.....	2
170931	Barrier Infill Panel, Specify Color.....	1
205507	Ladder Rung Cable, Black.....	*
205506	Top End Cable, Black.....	1
191086	T-Cable Connectors.....	4
139861	Handhold Hardware Package	2
100196	3/8" x 7/8" BHCS w/Pin, SST.....	4
100198	3/8" x 1 1/8" BHCS w/Pin, SST.....	4
100351	3/8" Tee Nut, SST.....	4
100353	3/8" Flange Nut w/Pin, SST.....	6
100365	3/8" SAE Flat Washer, SST.....	4
124460	3/8" x 3 3/4" BHCS w/Pin, SST.....	2
170993	Single Barrier w/Infill Hardware Package	1
100196	3/8" x 7/8" BHCS w/Pin, SST.....	5
100198	3/8" x 1 1/8" BHCS w/Pin, SST.....	2
100199	3/8" x 2 1/4" BHCS w/Pin, SST.....	2
100203	5/8" x 2 1/4" BHCS w/Pin, SST.....	1
100327	3/8" Standard Hex Nut, SST.....	2
100351	3/8" Tee Nut, SST.....	2
100353	3/8" Flange Nut w/Pin, SST.....	5
100365	3/8" SAE Flat Washer, SST.....	9
255156	Seeker Climber Hardware Package	1
100198	3/8" x 1 1/8" BHCS w/Pin, SST.....	24
100290	3/8" x 7/8" BHCS w/Pin Limited Thread, SST.....	8
100362	3/8" Flat Washer, SST.....	40
156962	5/8" O.D. x 1/2" Bushing, SST.....	8
100353	3/8" Flange Nut w/Pin, SST.....	40
100195	3/8" x 5/8" BHCS w/Pin, SST.....	40
138915	Bolt Link, SST.....	8
100292	3/8" x 1 1/4" BHCS w/Pin Limited Thread, SST.....	13
196319	Bolt Link Spacer.....	8
100351	3/8" Tee Nut, SST.....	24
100610	1/4" x 5/8" Drive Rivet, AL/SST.....	12
128296	3/8" Jam Nuts, SST.....	24
132626	BHCS 6LP 5/16" x 7/8", SST.....	5
175006	Flg Nut 6LP 5/16", SST.....	5
191086	T-Cable Connectors.....	2
205004	Net Clamp Hardware Package	*
100198	3/8" x 1 1/8" BHCS w/Pin, SST.....	4
100351	3/8" Tee Nut, SST.....	4
128296	3/8" Jam Nuts, SST.....	4
127179	5/8" O.D. x 3/8" Bushing, SST.....	2
100290	3/8" x 7/8" BHCS w/Pin Ltd. Thread Bolt, SST.....	2

* = Quantity Determined By Your Order

Specifications

Supports: Weldment comprised of 2.375" (60,33 mm) O.D. RS40 (.130"-.140") (3,30 mm-3,56 mm) wall galvanized steel tube, and 1/4" (6,35 mm) HRPO flat steel. Finish: ProShield®, color specified.

Cable Assembly: (Cable) Made of tightly woven polyester-wrapped, six-stranded galvanized-steel cable with a polypropylene core. (Cable Connectors) 6063-T6 aluminum.

Belts: .315" (8,00 mm) Thick mini rough top rubber belting with polyester fabric plys, black in color.

Infill Panel: Recycled Permalene®, color specified.

Handhold Panels: Recycled Permalene®, color specified.

Barrier: Weldment comprised of 1.125" (28,57 mm) O.D. 11 GA. (.120") (3,05 mm) steel tube per ASTM A513 with 203 or 303 stainless steel threaded inserts with 5/8" (15,88 mm) internal threads and 1/4" (6,35 mm) tabs. Finish: TenderTuft™, color specified.

Net Clamps: Weldment comprised of 1/4" (6,35 mm) x 1 3/4" (44,45 mm) HRPO flat steel and .375" (9,53 mm) stainless steel sheet. Finish: ProShield, color specified.

5" Clamps: Cast aluminum. Finish: ProShield, color specified.

Fasteners: Primary fasteners shall be socketed and pinned tamperproof in design, stainless steel (SST) per ASTM F879 unless otherwise indicated (see specific product installation/specifications).

Installation Time: 4 man hours

Weight: 16" to 48" Decks 224 lbs.

24" to 56" Decks 231 lbs.

32" to 64" Decks 238 lbs.

40" to 72" Decks 238 lbs.

Fall Height: Highest Deck Height

Installation Instructions

- 1) Attach handhold panels to lower deck. Refer to the Handhold Attachment Detail & Typical Offset Hanger Clamp Spec Sheet.
- 2) Attach barrier with infill panel to upper deck. Refer to the Barrier w/ Infill Panel Attachment Detail & Typical Offset Hanger Clamp Spec Sheet.
- 3) Attach supports to posts at height shown. Refer to the Support Attachment Detail.
- 4) Attach net clamps to posts at height shown. Refer to the Net Clamp Attachment Detail.
- 5) Attach net to net clamps. Refer to sheet one and the Net Attachment Detail.
- 6) Attach Top End Cable. Refer to the Top End Cable Attachment Detail.
- 7) Attach ladder rung cables below upper deck. Refer to the Ladder Rung Cable Attachment Detail.
- 8) Attach belts to net. Refer to the Belt Attachment Detail.
- 9) Install 1/4" x 5/8" drive rivets in all 5" half clamps. Drill through hole in 5" half clamps and into 5" post with a 1/4" or "F" (only) drill bit, insert drive rivet in hole through clamp and into post. Hammer drive rivet pin in until flush with head. Refer to the Typical Offset Hanger Clamp Spec Sheet.
- 10) Install protective surfacing before users are allowed to play on the structure.

**DETAIL
SUPPORT ATTACHMENT**

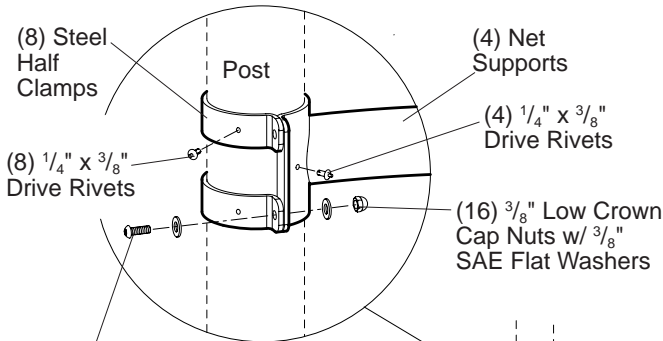

**DETAIL
NET TO SUPPORT ATTACHMENT**

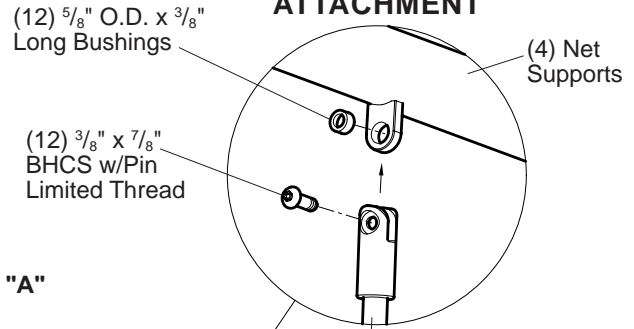

(16) 3/8" x 1 1/8" BHCS w/Pin w/ 3/8" SAE Flat Washers
(2) Barriers
(2) Infill Panels
NOTE: Attach nets to supports with the letter "A" positioned, as shown.

**DETAIL
NET TO CLAMP ATTACHMENT**

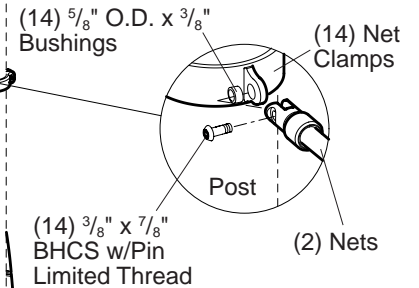

**DETAIL
CLAMP ATTACHMENT**

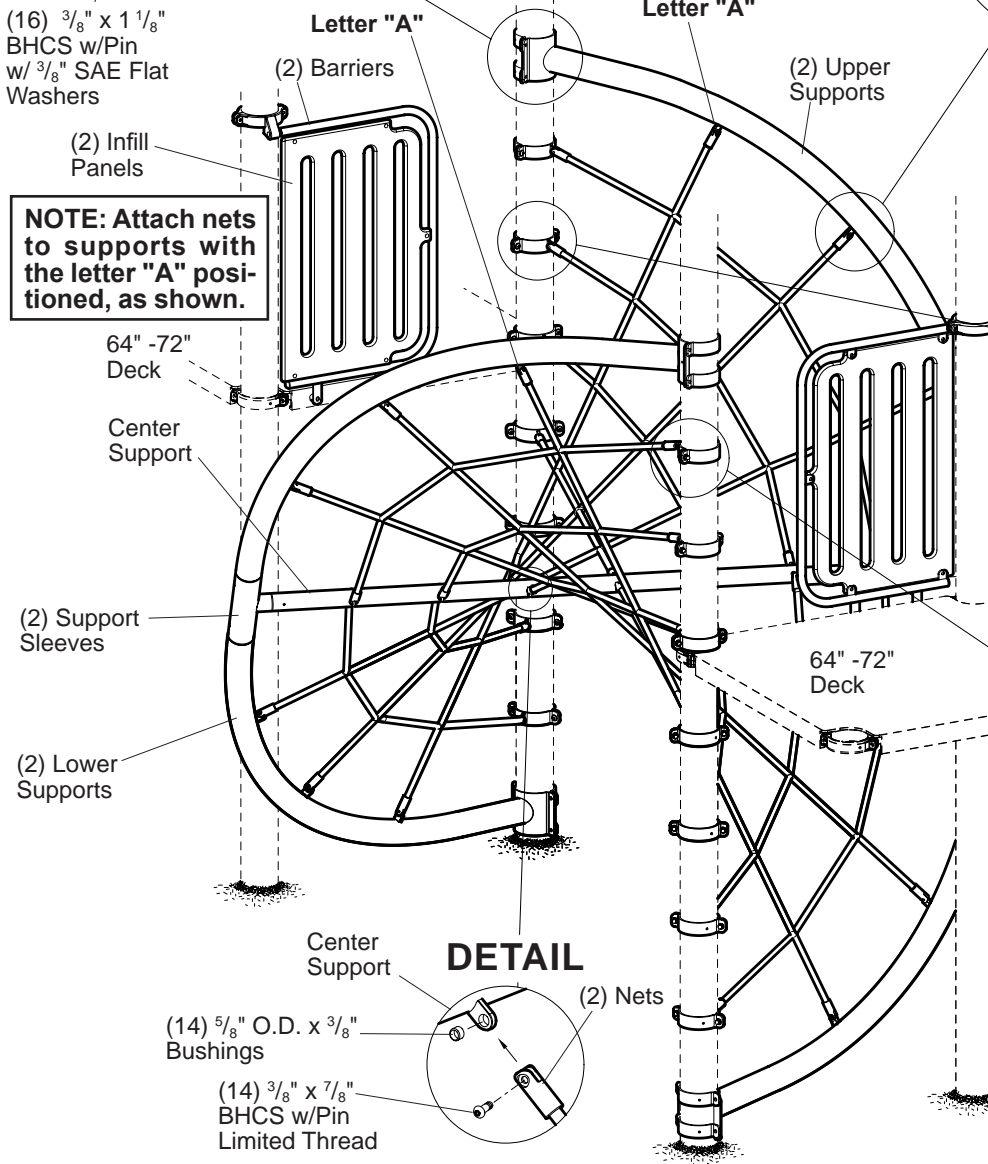
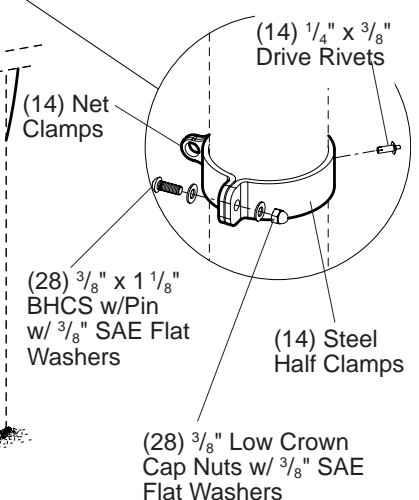

DETAIL

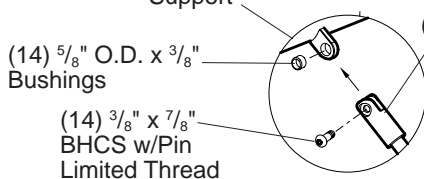

BARRIER ATTACHMENT DETAILS

DETAIL INFILL PANEL ATTACHMENT

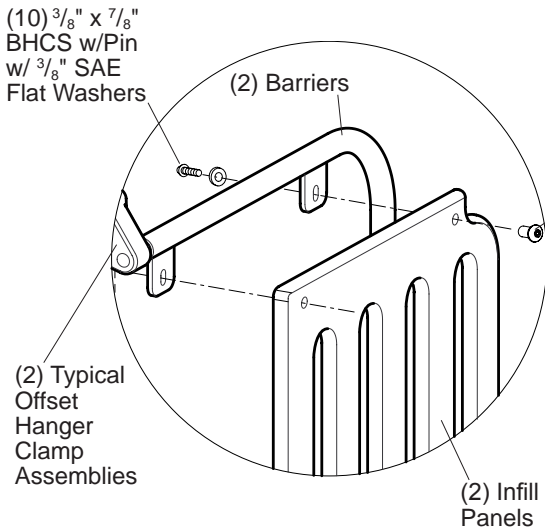

DETAIL BARRIER & INFILL PANEL

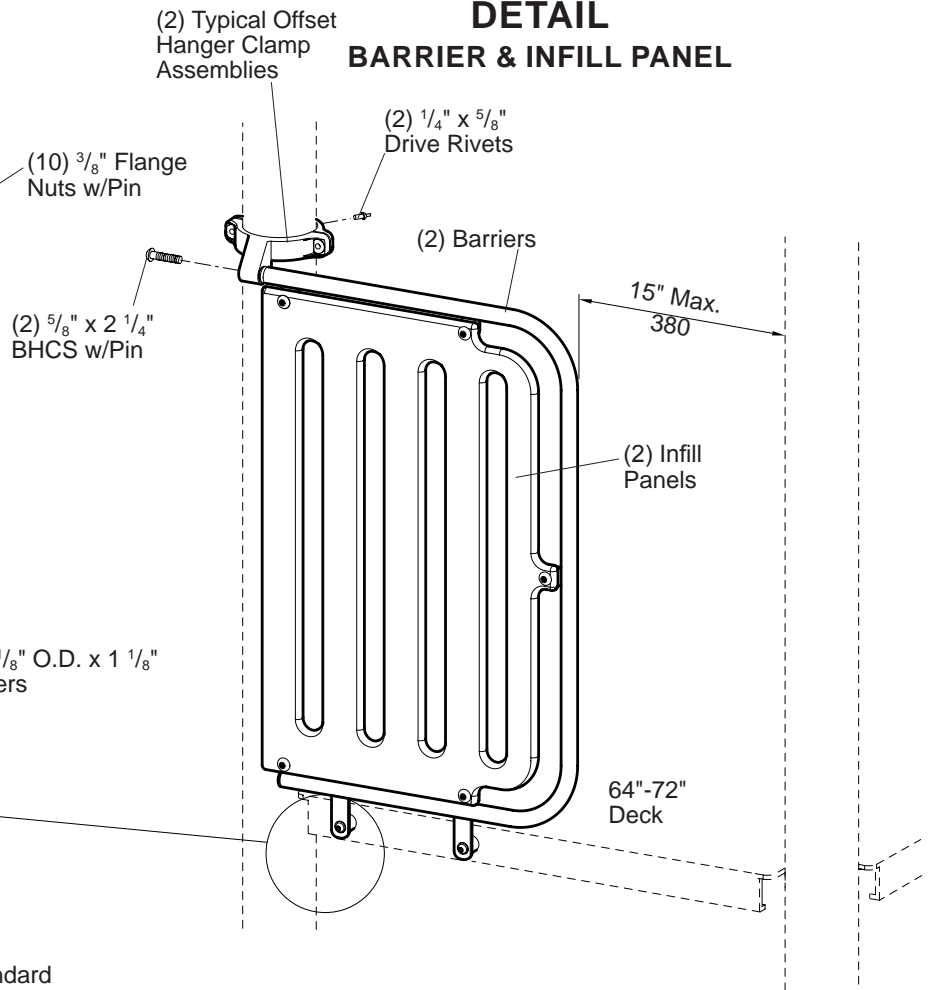

DETAIL BARRIER TO DECK ATTACHMENT

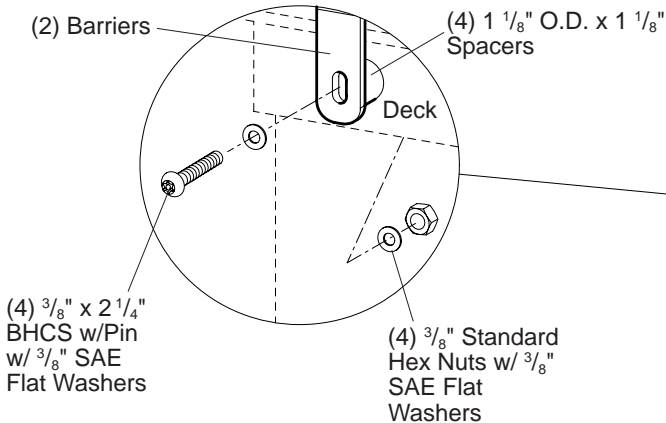

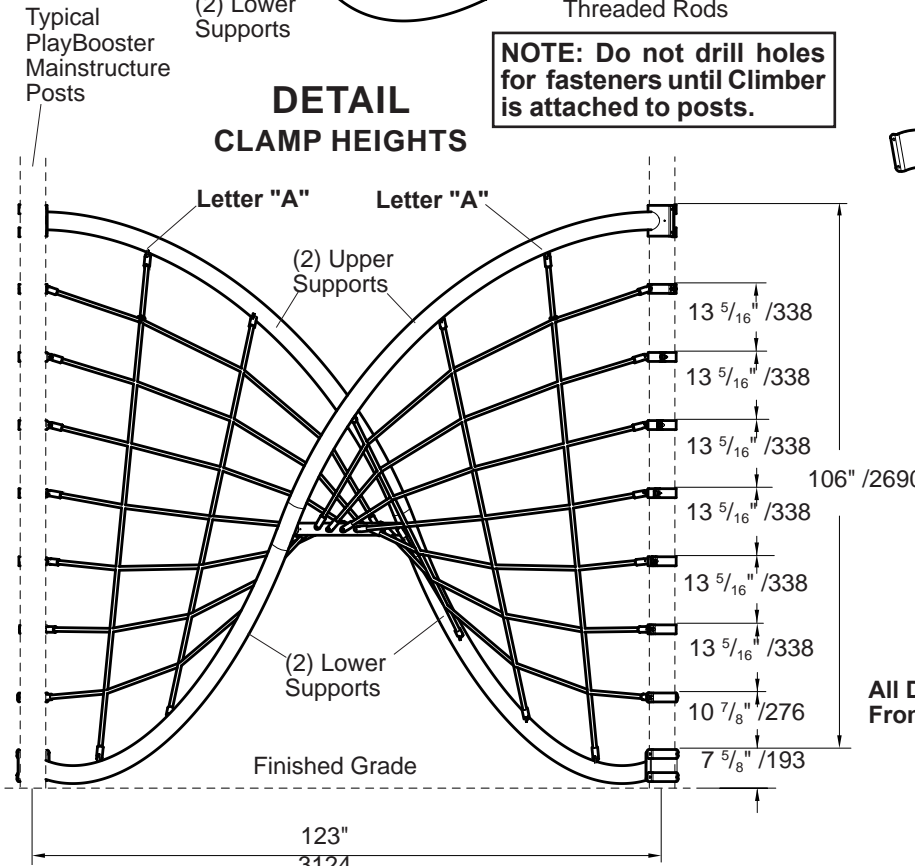
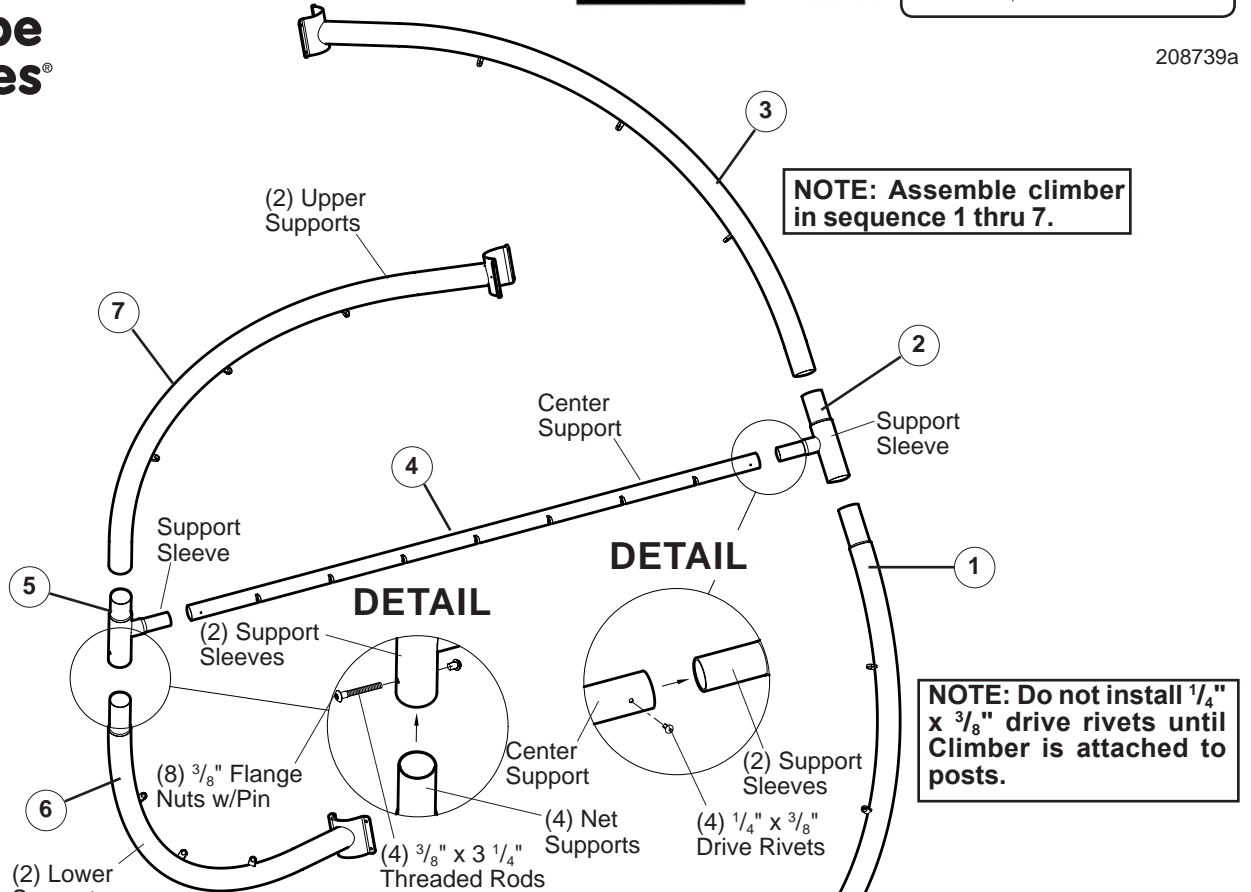

NOTE: Lower all clamps if there is a clamp conflict.

Parts List

Part#	Description	Qty.
100610	1/4" x 5/8" Drive Rivet, AL/SST	2
100611	1/4" x 3/8" Drive Rivet, AL/SST	26
104731	1 3/4" Steel Half Clamp, Specify Color	22
105327	5" Half Clamp, Specify Color	2
113729	5" Offset Hanger Clamp, Specify Color	2
151072	1 1/8" O.D. x 1 1/8" Spacer, AL., Specify Color	4
161898	Net Clamp, Specify Color	14
170931	Infill Panel, Specify Color	2
170930	Barrier, Specify Color	2
192608	Center Support, Specify Color	1
202623	Flex Climber Net, Black	2
208736	Upper Support, Specify Color	2
201306	Lower Support, Specify Color	2
201311	Sleeve, Specify Color	2
170993	Single Barrier w/Infill Hardware Package	2
100196	3/8" x 7/8" BHCS w/Pin, SST	10
100198	3/8" x 1 1/8" BHCS w/Pin, SST	4
100199	3/8" x 2 1/4" BHCS w/Pin, SST	4
100203	5/8" x 2 1/4" BHCS w/Pin, SST	2
100327	3/8" Standard Hex Nut, SST	4
100351	3/8" Tee Nut, SST	4
100353	3/8" Flange Nut w/Pin, SST	10
100365	3/8" SAE Flat Washer, SST	18
201509	Flex Climber Hardware Package	1
100198	3/8" x 1 1/8" BHCS w/Pin, SST	44
100365	3/8" SAE Flat Washer, SST	88
100349	3/8" Low Crown Cap Nut, SST	44
100290	3/8" x 7/8" BHCS w/Pin Limited Thread, SST	40
100353	3/8" Flange Nut w/Pin, SST	8
100611	1/4" x 3/8" Drive Rivet, AL/SST	4
127179	5/8" O.D. x 3/8" Bushing, SST	40
176539	3/8" x 3 1/4" Threaded Rod, SST	4

Specifications

Cable Assembly:	(Cable) Made of tightly woven polyester-wrapped, six-stranded galvanized-steel cable with a polypropylene core. (Cable Connectors) 6063-T6 aluminum.
Net Support:	Weldment comprised of 3.500" (88,9 mm) O.D. RS20 .125" (3,18 mm) wall galvanized steel tubing, 3/8" (9,53 mm) thick SST plate, and 1/4" (6,35 mm) HRPO flat steel. Finish: ProShield®, color specified.
Center Support:	Weldment comprised of 2.375" (60,33 mm) O.D. RS40 (.130" - .140") (3,30 mm-3,56 mm) wall galvanized steel tubing and 3/8" (9,53 mm) thick SST plate. Finish: ProShield, color specified.
Support Sleeve:	Weldment comprised of 3.500" (88,9 mm) O.D. RS20 .125" (3,18 mm) wall galvanized steel tubing, and 2.375" (60,33 mm) O.D. RS40 (.130" - .140") (3,30 mm-3,56 mm) wall galvanized steel tubing. Finish: ProShield, color specified.
Infill Panel:	Recycled Permalene®, color specified.
Barrier:	Weldment comprised of 1.125" (28,58 mm) O.D. 11 Ga. (.120") (3,05 mm) wall steel tube per ASTM A513 with 203 or 303 stainless steel threaded inserts with 5/8" (15,88 mm) internal threads and 1/4" (6,35 mm) tabs. Finish: TenderTuff®, color specified.
Steel Half Clamps:	Fabricated from of 1/4" (6,35 mm) HRPO flat steel. Finish: ProShield, color specified.
Net Clamp:	Weldment comprised of 1/4" (6,35 mm) x 1 3/4" (44,45 mm) HRPO flat steel and .375" (9,53 mm) stainless steel sheet. Finish: ProShield, color specified.
5" Clamps:	Cast aluminum. Finish: ProShield, color specified.
Fasteners:	Primary fasteners shall be socketed and pinned tamperproof in design, stainless steel (SST) per ASTM F 879 unless otherwise indicated (see specific product installation/specifications).
Installation Time:	Approx. 6 man hours
Weight:	393 lbs.
Fall Height:	99" (2,51 m)

Installation Instructions

- 1) Attach infill panels to barriers. Refer to the Barrier Attachment Details.
- 2) Attach barriers to decks. Refer to the Barrier Attachment Details.
- 3) Attach offset hanger clamps to barriers. Refer to the Barrier Attachment Details
- 4) Attach offset hanger clamps to posts, using 5" half clamps, $\frac{3}{8}$ " x $1\frac{1}{8}$ " BHCS w/pin and $\frac{3}{8}$ " tee nuts. Refer to the Typical Offset Hanger Clamp Assembly Sheet.
- 5) Attach lower net support to post at height shown. Assemble upper and lower supports to support sleeve, as shown. Attach upper net support to post. Refer to the Climber Assembly Detail. **NOTE:** *Assemble climber in sequence 1 thru 7.*
- 6) Slide center support onto support sleeve. Assemble upper and lower supports to support sleeve, as shown. Attach net supports to post. Refer to the Climber Assembly Detail. **NOTE:** *Assemble climber in sequence 1 thru 7.*
- 7) Drill through holes in supports and support sleeves with a $\frac{17}{32}$ " drill bit. Attach supports to support sleeves using $\frac{3}{8}$ " flange nuts with pin and $\frac{3}{8}$ " x $3\frac{1}{4}$ " threaded rods.
- 8) Attach net clamps to posts at height shown.
- 9) Attach nets to net supports, center support and net clamps with the **letter "A"** positioned on top, as shown.
- 10) Drill through holes in center support and into support sleeves with a $\frac{1}{4}$ " or "F" (only) drill bit, insert $\frac{1}{4}$ " x $\frac{3}{8}$ " drive rivets into holes. Hammer drive rivet pin in until flush with head.
- 11) Install $\frac{1}{4}$ " x $\frac{3}{8}$ " drive rivets in all steel half clamps. Drill through hole in steel half clamps and into 5" post with a $\frac{1}{4}$ " or "F" (only) drill bit, insert drive rivet in hole through clamp and into post. Hammer drive rivet pin in until flush with head.
- 12) Install $\frac{1}{4}$ " x $\frac{5}{8}$ " drive rivets in all 5" half clamps. Drill through hole in 5" half clamps and into 5" post with a $\frac{1}{4}$ " or "F" (only) drill bit, insert drive rivet in hole through clamp and into post. Hammer drive rivet pin in until flush with head. Refer to the Typical Offset Hanger Clamp Spec Sheet.
- 13) Install protective surfacing before users are allowed to play on the structure.

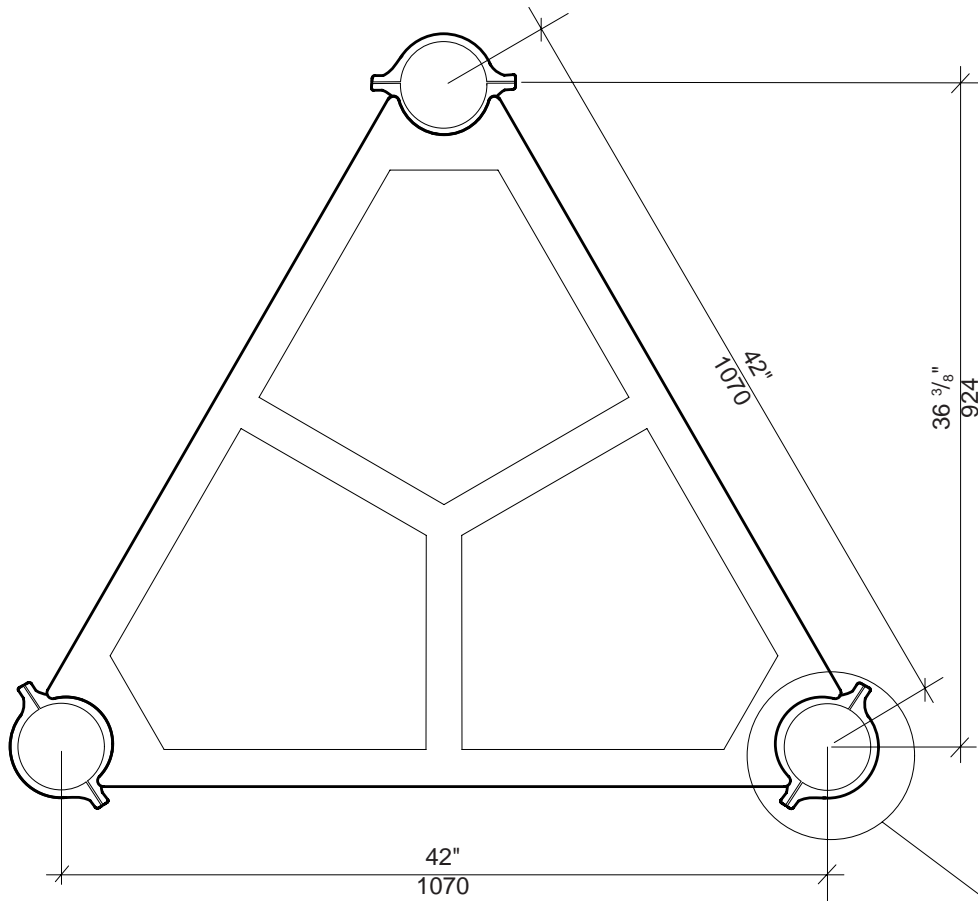

**DETAIL
DECK HANGER CLAMP**

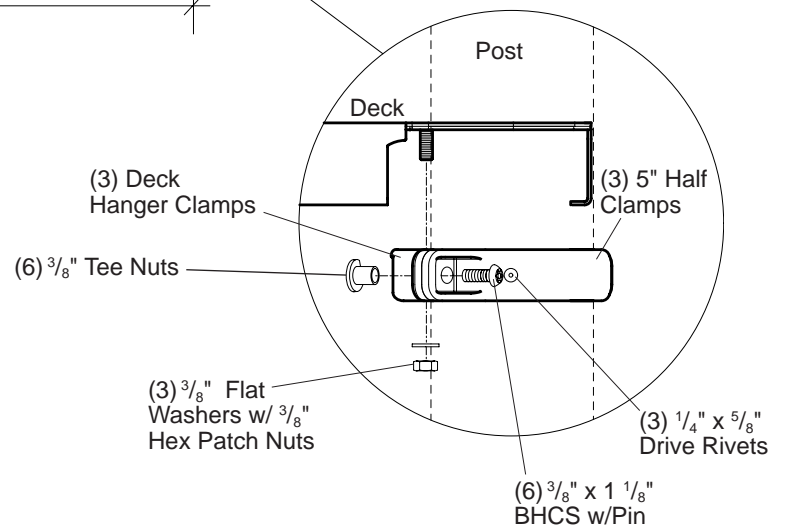

DETAIL

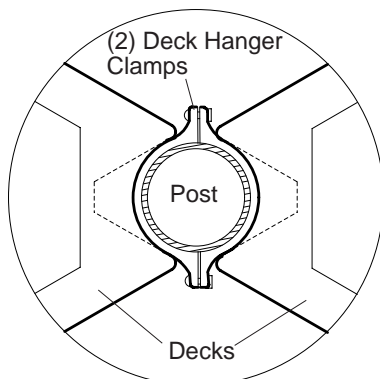

Configuration for Back to Back Decks at Same Height.



PlayBooster® 111231 Triangular Tenderdeck

Parts List

Part#	Description	Qty.
145657	Tri-Deck, Specify Color	1
105327	5" Half Clamp, Specify Color	3
106022	Deck Hanger Clamp, Specify Color.....	3
120203	Triangular Deck Hardware Package	1
100198	$\frac{3}{8}$ " x $1\frac{1}{8}$ " BHCS w/Pin, SST	6
100321	$\frac{3}{8}$ " Hex Patch Nut, SST.....	3
100351	$\frac{3}{8}$ " Tee Nut, SST.....	6
100362	$\frac{3}{8}$ " Flat Washer, SST	3
100610	$\frac{1}{4}$ " x $\frac{5}{8}$ " Drive Rivet, AL/SST	3

Specifications

Triangular Deck: Flange formed from 12 GA (.105") sheet steel conforming to ASTM A1011. Standing surface is perforated with $\frac{5}{16}$ " diameter holes. Deck face has (4) slotted holes for face mounting components. The finished size measures $2\frac{5}{8}$ " x $37\frac{3}{4}$ ". Finish: TenderTuff™, color specified.

Deck Hanger Clamp Assembly: Cast aluminum. Finish: ProShield®, color specified.

Fasteners: Primary fasteners shall be socketed and pinned tamperproof in design, stainless steel (SST) per ASTM F 879 unless otherwise indicated (see specific product installation/specifications).

Installation Time: Approx. $\frac{1}{2}$ man hour
Weight: 61 lbs.

Installation Instructions

- 1) Mark posts for the appropriate height of the deck you are installing.
- 2) Fasten deck hanger clamps to marked position on posts. See Detail on the front of this sheet.
- 3) Lift deck assembly into position, lining up stud underneath deck with deck hanger clamp as shown. Attach using $\frac{3}{8}$ " hex patch nuts with $\frac{3}{8}$ " flat washers. With deck level and posts plumb, final tighten all hardware.
- 4) Install $\frac{1}{4}$ " x $\frac{5}{8}$ " drive rivets in all 5" half clamps. Refer to the Typical Offset Hanger Clamp Spec Sheet.
- 5) After attachment of enclosures and components is complete, pour concrete footings. Allow concrete footings to cure a minimum of 72 hours before users are allowed to play on the structure.
- 6) Install protective surfacing before users are allowed to play on the structure.

NOTE: The Tri-Deck Extension can attach to all other deck styles.

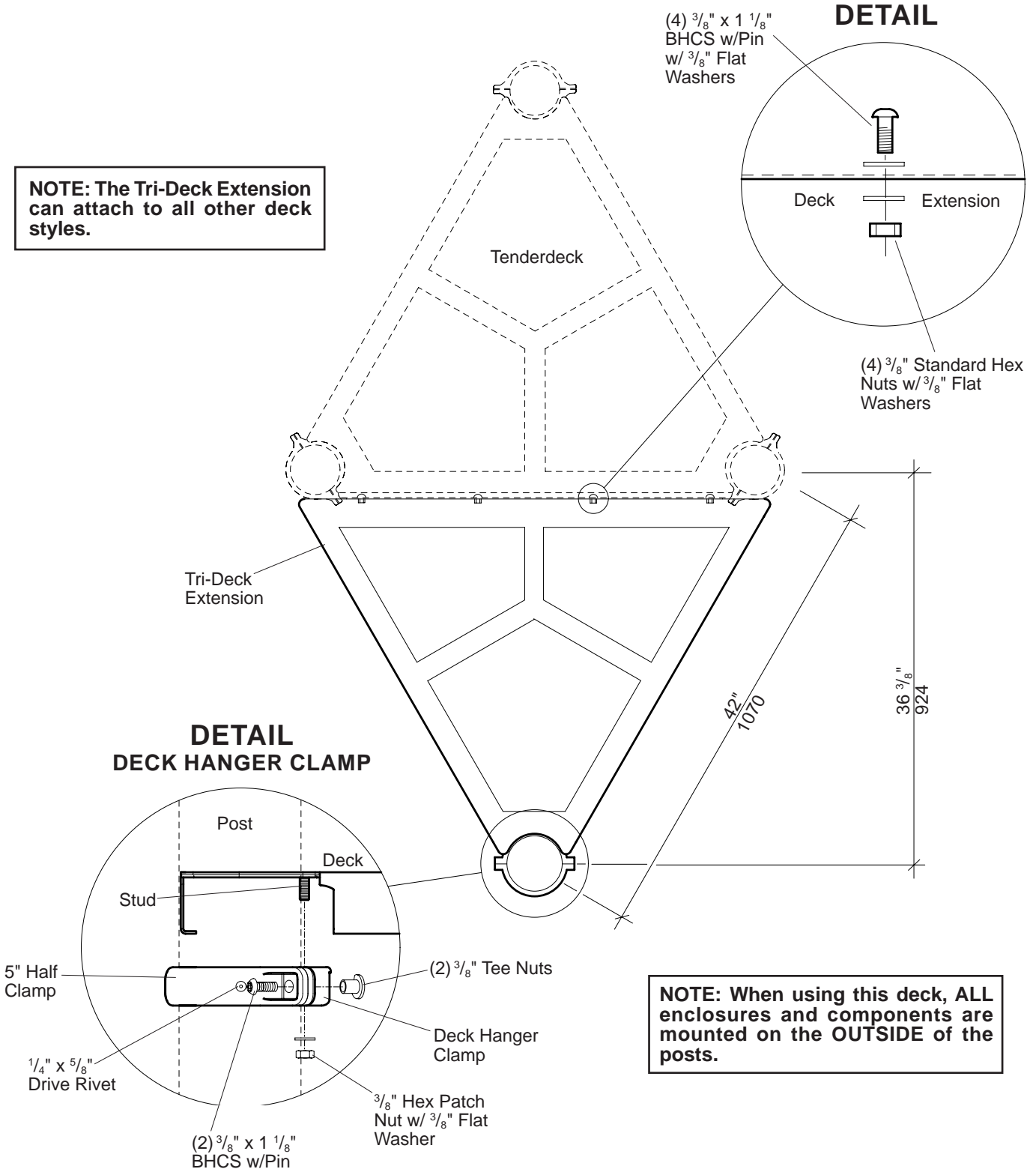

PlayBooster® 119646 Triangular Tenderdeck Extension



PlayBooster® 119646 Triangular Tenderdeck Extension

Parts List

Part#	Description	Qty.
145663	Tri-Deck Extension, Specify Color	1
105327	5" Half Clamp, Specify Color	1
106022	5" Deck Hanger Clamp, Specify Color	1
119593	Tri-Deck Extension Hardware Package	1
100198	3/8" x 1 1/8" BHCS w/Pin, SST	6
100321	3/8" Hex Patch Nut, SST.....	1
100327	3/8" Standard Hex Nut, SST	4
100351	3/8" Tee Nut, SST.....	2
100362	3/8" Flat Washer, SST	9
100610	1/4" x 5/8" Drive Rivet, AL/SST	1

Specifications

Tri-Deck

Extension: Flange formed from 12 GA (.105") sheet steel conforming to ASTM A1011. Standing surface is perforated with 5/16" diameter holes. Deck face has (4) slotted holes for face mounting components. The finished size of two of the three sides measures 2 5/8" x 37 7/8" on the face of the deck and the other side measures 2 5/8" x 43 3/4". Finish: TenderTuff™, color specified.

Deck Hanger Clamp Assembly:

Cast aluminum. Finish: ProShield®, color specified.

Fasteners:

Primary fasteners shall be socketed and pinned tamperproof in design, stainless steel (SST) per ASTM F 879 unless otherwise indicated (see specific product installation/specifications).

Installation Time:

Approx. 3/4 man hour

Weight:

52 lbs.

Installation Instructions

- 1) Mark the post for the appropriate height of the deck you are installing.
- 2) Fasten the deck hanger clamp to the marked position on the post. Refer to the Deck Hanger Clamp Detail.
- 3) Lift the deck into position, line up the studs underneath the deck with the deck hanger clamp. Attach using a 3/8" hex patch nut and 3/8" flat washer, as shown.
- 4) Attach the tri-deck extension to the tenderdeck using 3/8" x 1 1/8" BHCS w/pin with 3/8" flat washers and 3/8" standard hex nuts with 3/8" flat washers.
- 5) With the tri-deck extension level and the post plumb, install the 1/4" x 5/8" drive rivet in the 5" half clamp. Refer to the Typical Offset Hanger Clamp Spec Sheet.
- 6) Install protective surfacing before users are allowed to play on the structure.

**KICK PLATE
(FOR 6" OR 8" RISE)**

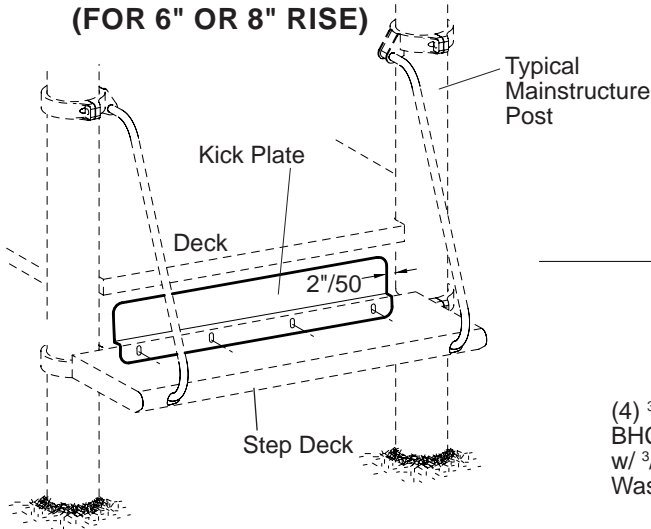

**DETAIL
KICK PLATE ATTACHMENT
(FOR 6" OR 8" RISE)**

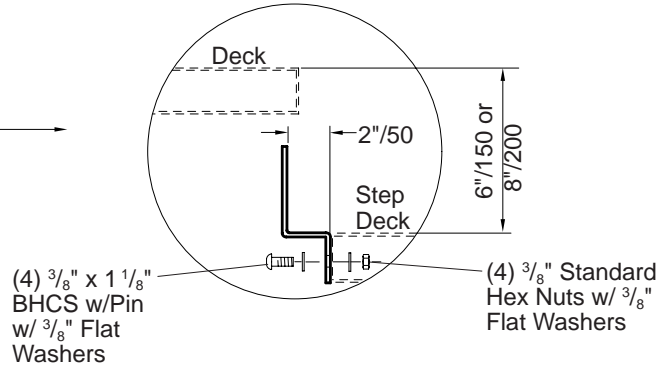

**KICK PLATE
(FOR 16" RISE)**

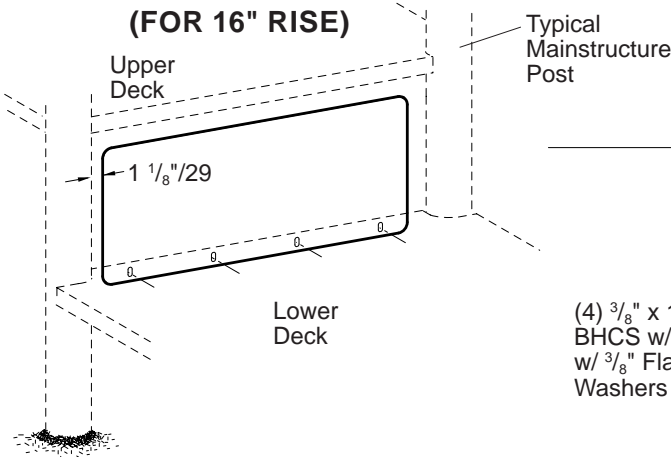

**DETAIL
KICK PLATE ATTACHMENT
(FOR 16" RISE)**

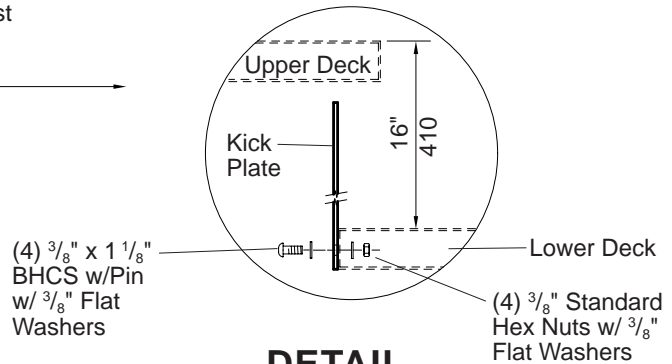

**KICK PLATE
(FOR 6" OR 8" RISE)**

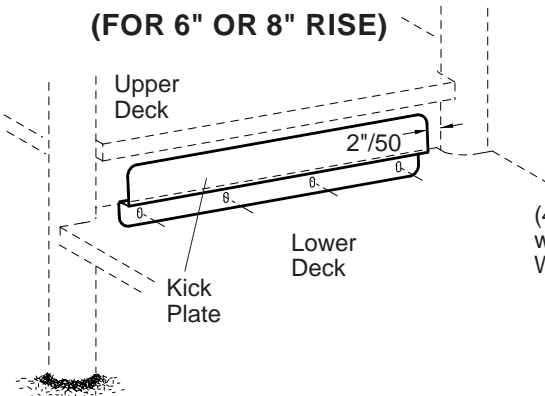

**DETAIL
KICK PLATE ATTACHMENT
(FOR 6" OR 8" RISE)**

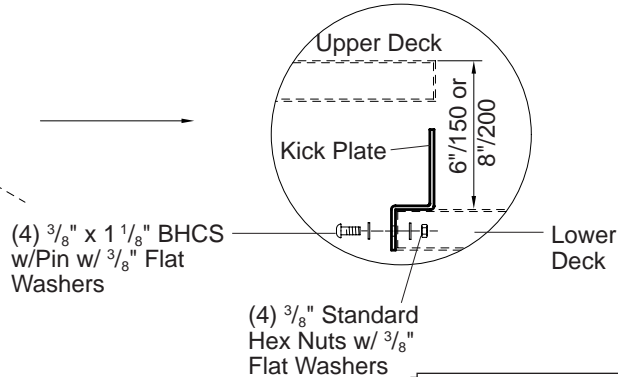

NOTE: Kick Plates mount to face of lower deck.

PlayBooster® 121948 Kick Plates, Tenderdecks, 6", 8" & 16"



PlayBooster® 121948 Kick Plates, Tenderdecks, 6", 8" & 16"

Parts List

Part#	Description	Qty.
121819	Kick Plate (For 6" or 8" Rise), Specify Color	1
121818	Kick Plate (For 16" Rise), Specify Color	1
156058	Kick Plate Tenderdeck Hardware Package	1
100198	$\frac{3}{8}$ " x $1\frac{1}{8}$ " BHCS w/Pin, SST.....	4
100327	$\frac{3}{8}$ " Standard Hex Nut, SST	4
100362	$\frac{3}{8}$ " Flat Washer, SST	8

Specifications

Kick Plate: Fabricated from 11 GA (.120") HR flat steel. Finish: TenderTuff™, brown or gray in color.

Fasteners: Primary fasteners shall be socketed and pinned tamperproof in design, stainless steel (SST) per ASTM F 879 unless otherwise indicated (see specific product installation/specifications).

Installation Time: Approx. $\frac{1}{4}$ man hour
Weight: Kick Plate (For 6" or 8" Rise) 13 lbs.
 Kick Plate (For 16" Rise) 23 lbs.

Installation Instructions

- 1) Locate kick plates as labeled on your plan drawing.
- 2) Attach kick plate using $\frac{3}{8}$ " x $1\frac{1}{8}$ " BHCS w/pin with $\frac{3}{8}$ " flat washers and $\frac{3}{8}$ " standard hex nuts with $\frac{3}{8}$ " flat washers, as shown. **NOTE:** *Kick plates mount to face of lower deck.*
- 3) Install protective surfacing before users are allowed to play on the structure.

**KICK PLATE
(FOR 16" RISE)**

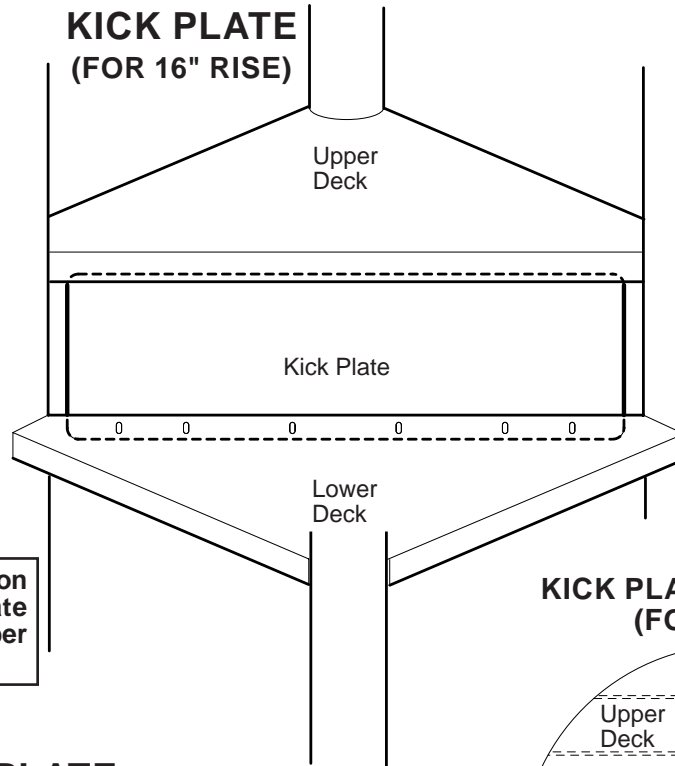

NOTE: Tri-Deck configuration may require the kick plate to be mounted to the upper deck.

**DETAIL
KICK PLATE ATTACHMENT
(FOR 16" RISE)**

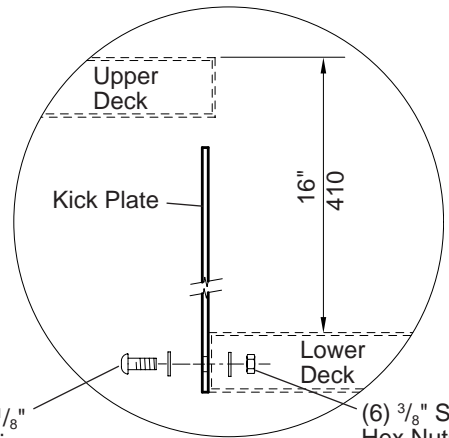

(6) $\frac{3}{8}$ " x $1\frac{1}{8}$ " BHCS w/Pin w/ $\frac{3}{8}$ " Flat Washers

(6) $\frac{3}{8}$ " Standard Hex Nuts w/ $\frac{3}{8}$ " Flat Washers

**KICK PLATE
(FOR 6" OR 8" RISE)**

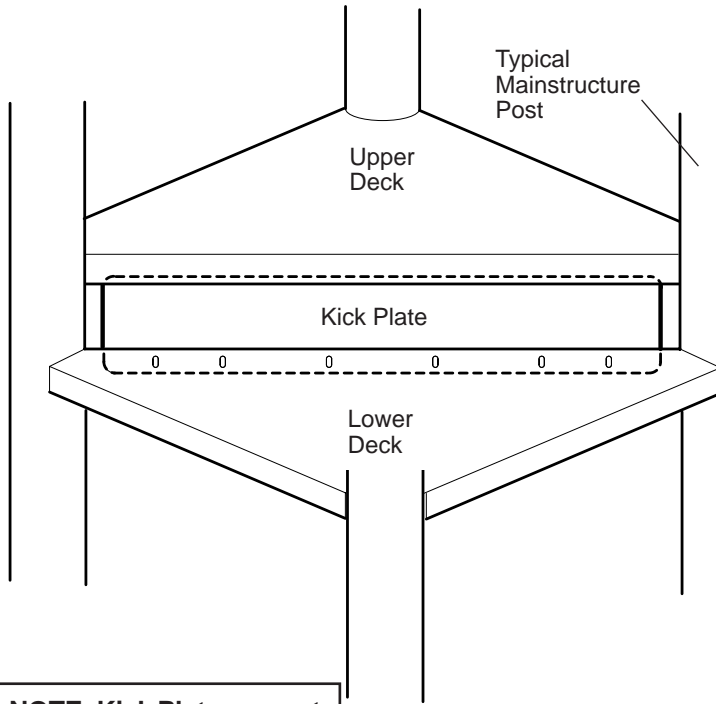

NOTE: Kick Plates mount to face of lower deck.

**DETAIL
KICK PLATE ATTACHMENT
(FOR 6" OR 8" RISE)**

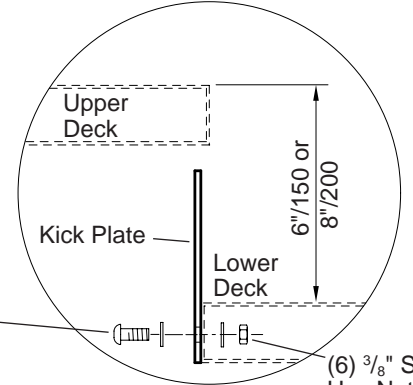

(6) $\frac{3}{8}$ " x $1\frac{1}{8}$ " BHCS w/Pin w/ $\frac{3}{8}$ " Flat Washers

(6) $\frac{3}{8}$ " Standard Hex Nuts w/ $\frac{3}{8}$ " Flat Washers

PlayBooster® 121949 Kick Plates, 90° Tri-Decks, 6", 8" & 16"



PlayBooster® 121949 Kick Plates, 90° Tri-Decks, 6", 8" & 16"

Parts List

Part#	Description	Qty.
121820	Kick Plate (For 6" or 8" Rise), Specify Color	1
121822	Kick Plate (For 16" Rise), Specify Color	1
156059	Kick Plate Tenderdeck Hardware Package	1
100198	$\frac{3}{8}$ " x $1\frac{1}{8}$ " BHCS w/Pin, SST	6
100327	$\frac{3}{8}$ " Standard Hex Nut, SST	6
100362	$\frac{3}{8}$ " Flat Washer, SST	12

Specifications

Kick Plate: Fabricated from 11 GA (.120") HR flat steel. Finish: TenderTuff™, color specified.

Fasteners: Primary fasteners shall be socketed and pinned tamperproof in design, stainless steel (SST) per ASTM F 879 unless otherwise indicated (see specific product installation/specifications).

Installation Time: Approx. $\frac{1}{4}$ man hour
Weight: Kick Plate (For 6" or 8" Rise) 13 lbs.
 Kick Plate (For 16" Rise) 33 lbs.

Installation Instructions

- 1) Locate kick plates as labeled on your plan drawing.
- 2) Attach kick plate using $\frac{3}{8}$ " x $1\frac{1}{8}$ " BHCS w/pin with $\frac{3}{8}$ " flat washers and $\frac{3}{8}$ " standard hex nuts with $\frac{3}{8}$ " flat washers, as shown. **NOTE:** *Kick plates mount to face of lower deck.*
- 3) Install protective surfacing before users are allowed to play on the structure.

**DETAIL
DECK HANGER CLAMP**

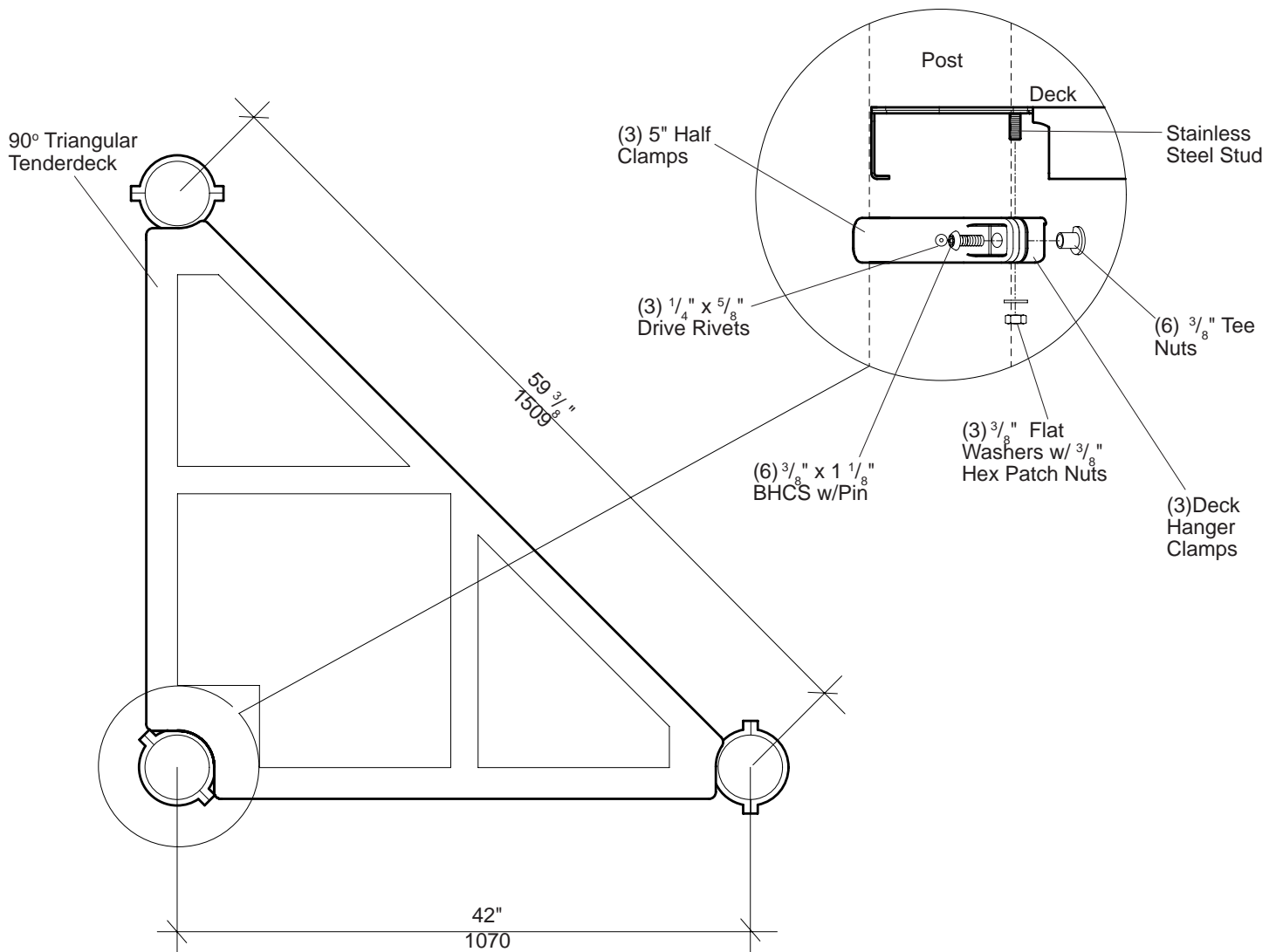

PlayBooster® 122197 90° Triangular Tenderdeck



PlayBooster® 122197 90° Triangular Tenderdeck

Parts List

Part#	Description	Qty.
145658	90° Tri-Deck, Specify Color	1
105327	5" Half Clamp, Specify Color	3
106022	Deck Hanger Clamp, Specify Color.....	3
120203	Triangular Deck Hardware Package	1
100198	$\frac{3}{8}$ " x $1\frac{1}{8}$ " BHCS w/Pin, SST	6
100321	$\frac{3}{8}$ " Hex Patch Nut, SST.....	3
100351	$\frac{3}{8}$ " Tee Nut, SST.....	6
100362	$\frac{3}{8}$ " Flat Washer, SST	3
100610	$\frac{1}{4}$ " x $\frac{5}{8}$ " Drive Rivet, AL/SST.....	3

Specifications

Triangular Deck: Flange formed from 12 GA (.105") sheet steel conforming to ASTM A1011. Standing surface is perforated with $\frac{5}{16}$ " diameter holes. Deck face has (4) slotted holes for face mounting components. The finished size measures $2\frac{5}{8}$ " x $37\frac{3}{4}$ ". Finish: TenderTuff™, color specified.

Deck Hanger Clamp Assembly: Cast aluminum. Finish: ProShield®, color specified.

Fasteners: Primary fasteners shall be socketed and pinned tamperproof in design, stainless steel (SST) per ASTM F 879 unless otherwise indicated (see specific product installation/specifications).

Installation Time: Approx. $\frac{1}{2}$ man hour
Weight: 67 lbs.

Installation Instructions

- 1) Mark posts for the appropriate height of the deck you are installing.
- 2) Fasten deck hanger clamps to marked position on posts. See Detail on front of sheet.
- 3) Lift deck assembly into position, lining up stud underneath deck with deck hanger clamp as shown. Attach using $\frac{3}{8}$ " hex patch nuts with $\frac{3}{8}$ " flat washers. With deck level and posts plumb, final tighten all hardware.
- 4) Install $\frac{1}{4}$ " x $\frac{5}{8}$ " drive rivets in all 5" half clamps. Refer to the Typical Offset Hanger Clamp Spec Sheet.
- 5) After attachment of enclosures and components is complete, pour concrete footings. Allow concrete footings to cure a minimum of 72 hours before users are allowed to play on the structure.
- 6) Install protective surfacing before users are allowed to play on the structure.

PLAN/FOOTING LAYOUT

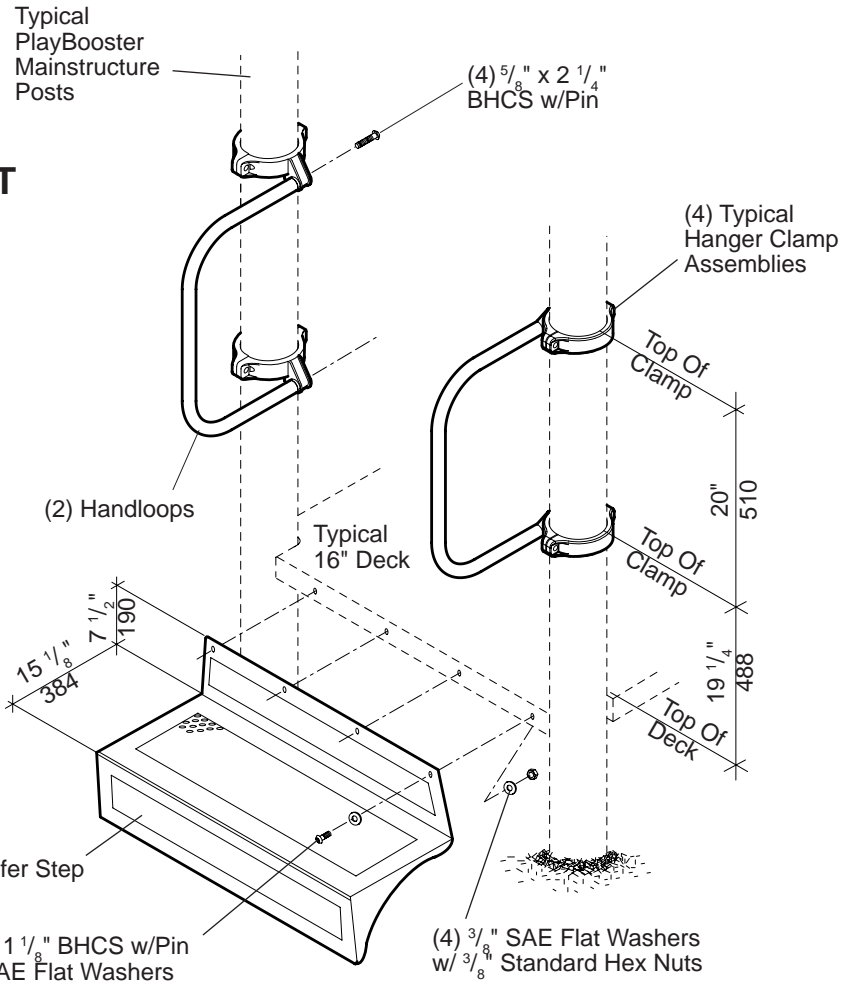
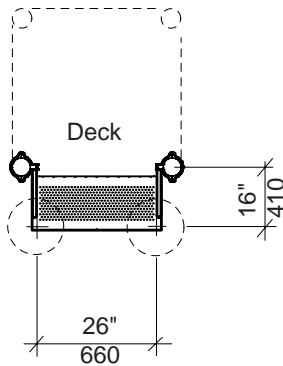

DIRECT BURY

SURFACE MOUNT

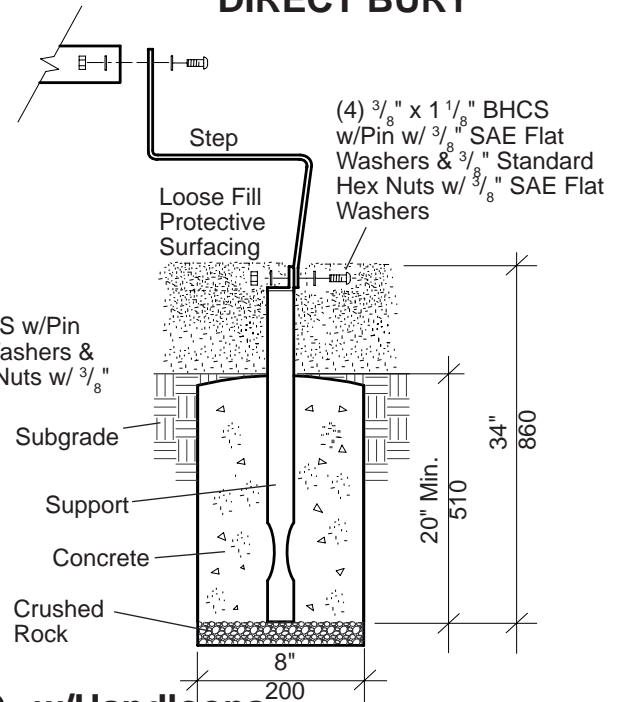
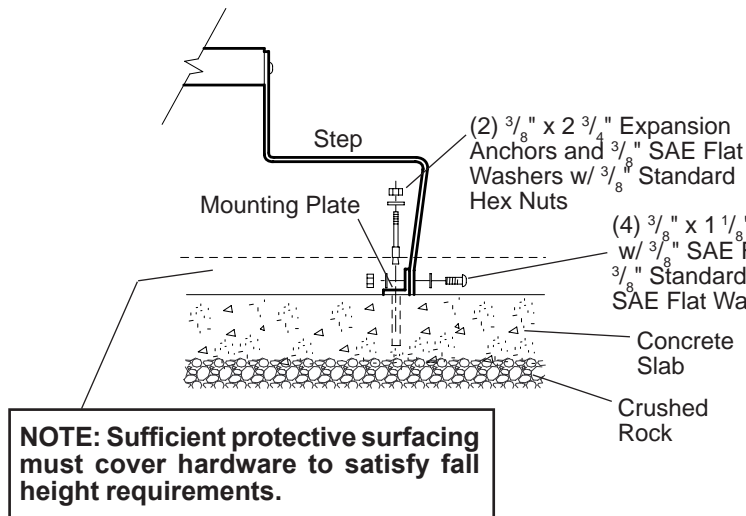



PlayBooster® 185852 Transfer Step, w/Handloops

Parts List

Part#	Description	Qty.
149024	Transfer Step, Specify Color	1
181342	Transfer Step, Support (DB), Specify Color	1
181343	Transfer Step, Mounting Plate (SM), Specify Color	1
105327	5" Half Clamp, Specify Color	4
113729	Offset Hanger Clamp, Specify Color	4
108542	Handloop, Specify Color	2
125741	Transfer Step Leg Hardware Package (DB)	1
100198	3/8" x 1 1/8" BHCS w/Pin, SST	4
100327	3/8" Standard Hex Nut, SST	4
100365	3/8" SAE Flat Washer, SST	8
125740	Transfer Step Leg Hardware Package (SM)	1
100198	3/8" x 1 1/8" BHCS w/Pin, SST	4
100263	3/8" x 2 3/4" Expansion Anchor	2
100327	3/8" Standard Hex Nut, SST	6
100365	3/8" SAE Flat Washer, SST	10
127148	Transfer Step Hardware Package	1
100198	3/8" x 1 1/8" BHCS w/Pin, SST	4
100365	3/8" SAE Flat Washer, SST	8
100327	3/8" Standard Hex Nut, SST	4
114309	Handloop/Rail Hardware Package	2
100198	3/8" x 1 1/8" BHCS w/Pin, SST	8
100203	5/8" x 2 1/4" BHCS w/Pin, SST	4
100351	3/8" Tee Nut, SST	8
100610	1/4" x 5/8" Drive Rivet, SST	4

DB = Direct Bury
SM = Surface Mount

Specifications

Step:	Formed from 12 GA (.105") sheet steel conforming to ASTM A1011. Finish: TenderTuff™, color specified.
Step Support:	Weldment comprised of 1.660 O.D. RS20 (.080"-.095) and 1 3/4" x 1 3/4" x 1/8" HR angle. Finish: ProShield®, color specified.
Handloop:	Weldment comprised of 1.125" O.D. 11 GA (.120") steel tubing with 203 or 303 stainless steel inserts, with 5/8" internal thread. Finish: TenderTuff, color specified.
Clamps:	Cast aluminum. Finish: ProShield®, color specified.
Fasteners:	Primary fasteners shall be socketed and pinned tamperproof in design, stainless steel (SST) per ASTM F 879 unless otherwise indicated (see specific product installation/specifications).
Installation Time:	Approx. 1 1/2 man hours
Concrete Req.:	DB - 1.16 cu. ft.
Weight:	SM - 69 lbs. DB - 77 lbs.

Specifications are subject to change without notice.

Installation Instructions

Direct Bury

- 1) Dig footings spaced as shown.
- 2) Mark locations of clamps on posts per dimensions on front of sheet.
- 3) Attach offset hanger clamps to ends of handloops using 5/8" x 2 1/4" BHCS w/pin.
- 4) Position handloops with offset hanger clamps on marked positions on posts and attach using 5" half clamps and 3/8" x 1 1/8" BHCS w/pin with 3/8" tee nuts. Refer to the Typical Offset Hanger Clamp Assembly Sheet.
- 5) Install drive rivets in half clamps per the Typical Offset Hanger Clamp Assembly Sheet.
- 6) Attach transfer step support to transfer step using 3/8" x 1 1/8" BHCS w/pin with 3/8" SAE flat washers and 3/8" standard hex nuts with 3/8" SAE flat washers.
- 7) Attach transfer step to deck using 3/8" x 1 1/8" BHCS w/pin with 3/8" SAE flat washers and 3/8" standard hex nuts with 3/8" SAE flat washers as shown.
- 8) With deck and steps in level position, pour concrete footings. Allow concrete to cure for a minimum of 72 hours before users are allowed to play on the structure.
- 9) Install protective surfacing before users are allowed to play on the structure.

Surface Mount

- 1) Mark locations of clamps on posts per dimensions on front of sheet.
- 2) Attach offset hanger clamps to ends of handloops using 5/8" x 2 1/4" BHCS w/pin.
- 3) Position handloops with offset hanger clamps on marked positions on posts and attach using 5" half clamps and 3/8" x 1 1/8" BHCS w/pin with 3/8" tee nuts. Refer to the Typical Offset Hanger Clamp Assembly Sheet.
- 4) Install drive rivets in half clamps per the Typical Offset Hanger Clamp Assembly Sheet.
- 5) Attach transfer step mounting plate to transfer step using 3/8" x 1 1/8" BHCS w/pin with 3/8" SAE flat washers and 3/8" standard hex nuts with 3/8" SAE flat washers.
- 6) Attach transfer step to deck using 3/8" x 1 1/8" BHCS w/pin with 3/8" SAE flat washers and 3/8" standard hex nuts with 3/8" SAE flat washers as shown.
- 7) Mark holes for expansion anchors on concrete slab through step mounting plate.
- 8) Detach step from deck and drill 3/8" x 3" deep holes into concrete on marks using 3/8" masonry bit and hammer drill.
- 9) Reattach transfer step to deck.
- 10) With step over drilled holes, tap expansion anchors into drilled holes. Secure using 3/8" standard hex nuts with 3/8" SAE flat washers.
- 11) Install protective surfacing before users are allowed to play on the structure.

ECO 54590 Created new model number and added handloops to Parts List.

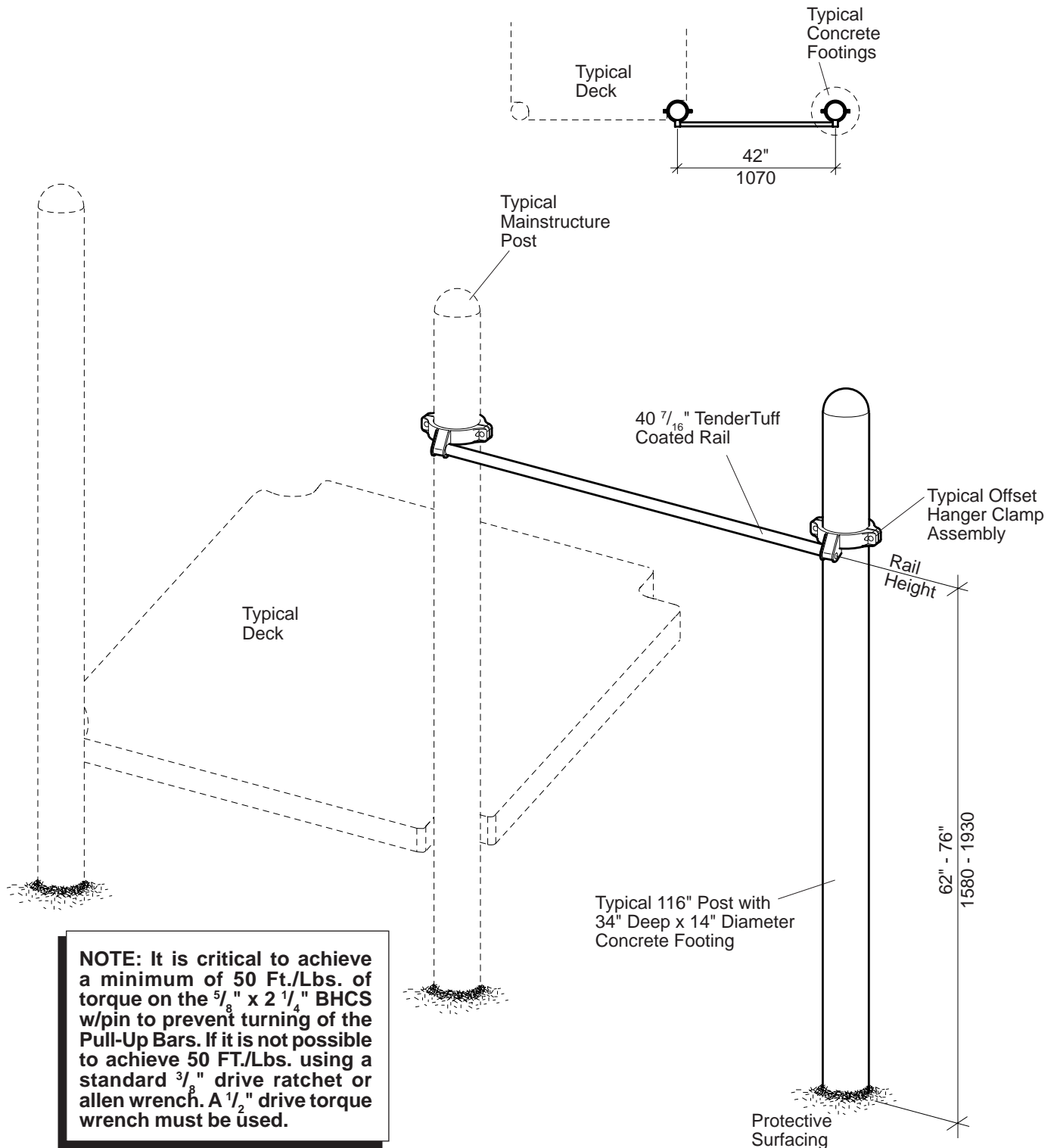

NOTE: It is critical to achieve a minimum of 50 Ft./Lbs. of torque on the 5/8" x 2 1/4" BHCS w/pin to prevent turning of the Pull-Up Bars. If it is not possible to achieve 50 FT./Lbs. using a standard 3/8" drive ratchet or allen wrench. A 1/2" drive torque wrench must be used.



PlayBooster® 111357 Chinning Bar

Parts List

Part#	Description	Qty.
107694	116" Aluminum Post, DB, Specify Color.....	1
107628	94" Aluminum Post, 12" SM, Specify Color.....	1
107623	84" Aluminum Post, 2" SM, Specify Color.....	1
107520	116" Steel Post, DB, Specify Color.....	1
107470	84" Steel Post, 2" SM, Specify Color.....	1
107473	94" Steel Post, 12" SM, Specify Color.....	1
108569	40 7/16" TenderTuff Rail, Specify Color.....	1
105327	5" Half Clamp, Specify Color.....	2
113729	Offset Hanger Clamp, Specify Color.....	2
100610	1/4" x 5/8" Drive Rivet, SST.....	2
100351	3/8" Tee Nut, SST.....	4
100198	3/8" x 1 1/8" BHCS w/Pin, SST.....	4
100203	5/8" x 2 1/4" BHCS w/Pin, SST.....	2

Specifications

Rail: Weldment comprised of 1.125" O.D. x 11 GA (.120") steel tubing with 203 or 303 stainless steel 5/8" threaded inserts. Finish: TenderTuff™, color specified.

Post: See PlayBooster® (PB) General Specifications.

Offset Hanger

Clamp Assembly: Cast aluminum. Finish: ProShield®, color specified.

Fasteners: Primary fasteners shall be socketed and pinned tamperproof in design, stainless steel (SST) per ASTM F 879 unless otherwise indicated (see specific product installation/specifications).

Installation Time: Approx. 1 1/2 man hours

Concrete Req.: Approx. 1.6 cu. ft.

Area Req.: 6' (1.83 m) minimum use zone

Weight:
 41 lbs. Aluminum DB
 38 lbs. Aluminum SM
 68 lbs. Steel SM
 80 lbs. Steel DB

Installation Instructions

- 1) Dig footing hole spaced as shown. Refer to the Typical Concrete Footing Detail sheet.
- 2) Set 92" post in footing hole and attach 40 7/16" rail assembly to post at height shown using offset hanger clamp. Refer to the Typical Offset Hanger Clamp Assembly Spec sheet. **NOTE:** It is critical to achieve a minimum of 50 Ft./Lbs. of torque on the 5/8" x 2 1/4" BHCS w/pin to prevent turning of the Pull-Up Bars. If it is not possible to achieve 50 FT./Lbs. using a standard 3/8" drive ratchet or allen wrench. A 1/2" drive torque wrench must be used.
- 3) Temporarily brace post in plumb position and level rail. Pour concrete footing.
- 4) Install drive rivets in all clamps. Refer to the Typical Offset Hanger Clamp Assembly sheet.
- 5) Install protective surfacing before users are allowed to play on the structure.

Top View

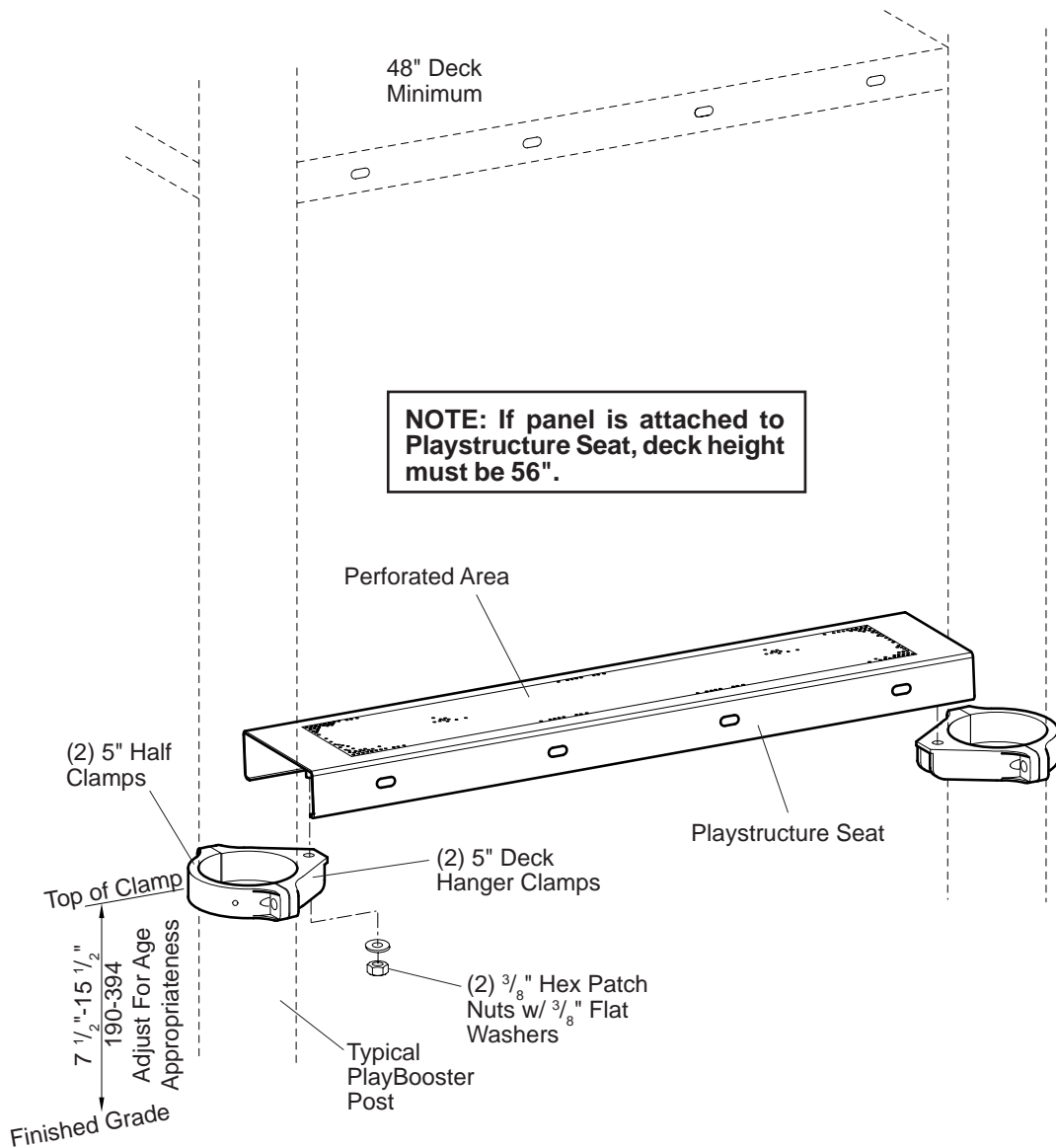
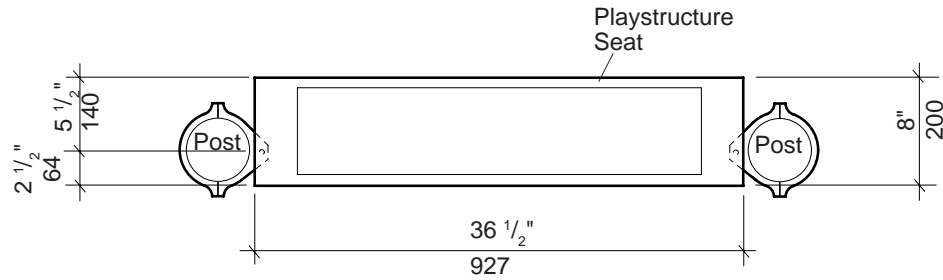

PlayBooster®

120818 Playstructure Seat

Parts List

Part#	Description	Qty.
153952	Playstructure Seat, Specify Color.....	1
105327	5" Half Clamp, Specify Color	2
106022	5" Deck Hanger Clamp, Specify Color	2
106676	Seat Hardware Package	1
100198	$\frac{3}{8}$ " x $1\frac{1}{8}$ " BHCS w/Pin, SST	4
100321	$\frac{3}{8}$ " Hex Patch Nut, SST.....	2
100351	$\frac{3}{8}$ " Tee Nut, SST.....	4
100362	$\frac{3}{8}$ " Flat Washer, SST	2
100610	$\frac{1}{4}$ " x $\frac{5}{8}$ " Drive Rivet, AL/SST	2

Specifications

Seat: Flange formed from 11 GA (.120") sheet steel. Seating surface is perforated with $\frac{5}{16}$ " diameter holes. Finish: TenderTuff™, color specified.

Deck Hanger Clamp Assembly: Cast aluminum. Finish: ProShield®, color specified.

Fasteners: Primary fasteners shall be socketed and pinned tamperproof in design, stainless steel (SST) per ASTM F 879 unless otherwise indicated (see specific product installation/specifications).

Installation Time: Approx. 1 man hour
Weight: 26 lbs.

Installation Instructions

- 1) Playstructure seat attaches offset to posts. Refer to your site layout for where and which direction the playstructure seat needs to be installed. **NOTE: If panel is attached to Playstructure Seat, deck height must be 56".**
- 2) Mark posts for the appropriate height of the playstructure seat you are installing. **NOTE: Height is adjustable 8"-16".**
- 3) Fasten 5" deck hanger clamps to the marked position on posts using 5" half clamps and $\frac{3}{8}$ " x $1\frac{1}{8}$ " BHCS w/pin with $\frac{3}{8}$ " tee nuts. Refer to the Typical Offset Hanger Clamp Spec Sheet.
- 4) Position seat over 5" deck hanger clamps and attach using $\frac{3}{8}$ " hex patch nuts with $\frac{3}{8}$ " flat washers, as shown.
- 5) Install $\frac{1}{4}$ " x $\frac{5}{8}$ " drive rivets in all 5" half clamps. Refer to the Typical Offset Hanger Clamp Spec Sheet.
- 6) Install protective surfacing before users are allowed to play on the structure.

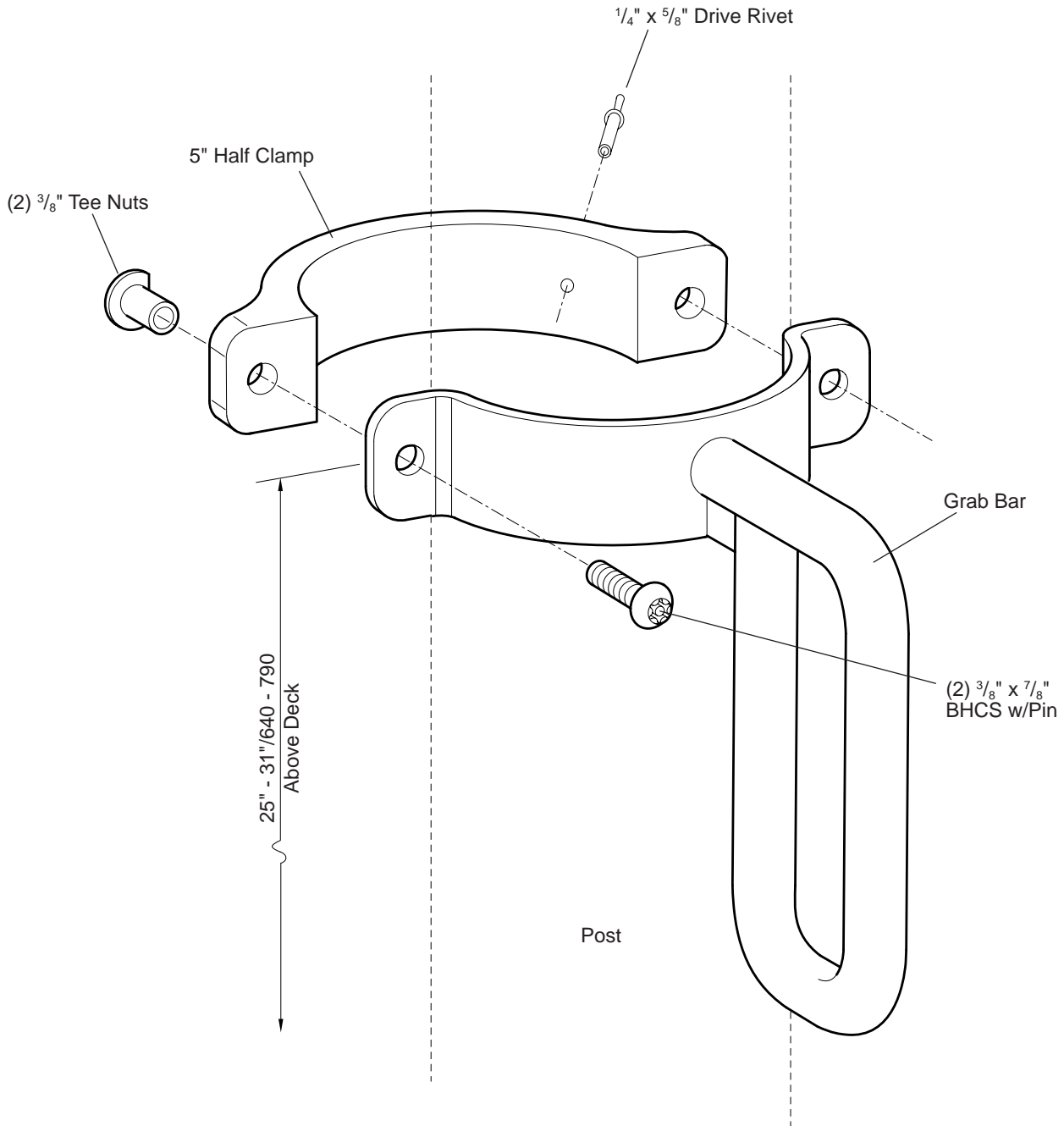



PlayBooster® 120901 Grab Bar

Parts List

Part#	Description	Qty.
105327	5" Half Clamp, Specify Color	1
141541	Grab Bar, Specify Color	1
106518	Grab Bar Hardware Package	1
100196	³ / ₈ " x ⁷ / ₈ " BHCS w/Pin, SST	2
100351	³ / ₈ " Tee Nut, SST.....	2
100610	¹ / ₄ " x ⁵ / ₈ " Drive Rivet, AL/SST	1

Specifications

Grab Bar: Weldment comprised of formed ⁷/₈" O.D. 11 GA (.120") and ¹/₄" x 1 ³/₄" stainless steel half clamp. Finish: TenderTuff™, color specified.

Half Clamp: Cast aluminum. Finish: ProShield®, color specified.

Fasteners: Primary fasteners shall be socketed and pinned tamperproof in design, stainless steel (SST) per ASTM F 879 unless otherwise indicated (see specific product installation/specifications).

Installation Time: Approx. ¹/₄ man hour
Weight: 5 lbs.

Installation Instructions

- 1) Attach grab bar to post at height shown, using a 5" half clamp, ³/₈" x ⁷/₈" BHCS w/pin and ³/₈" tee nuts.
- 2) Install ¹/₄" x ⁵/₈" drive rivet in 5" half clamp. Refer to the Offset Hanger Clamp Spec Sheet.
- 3) Install protective surfacing before users are allowed to play on the structure.

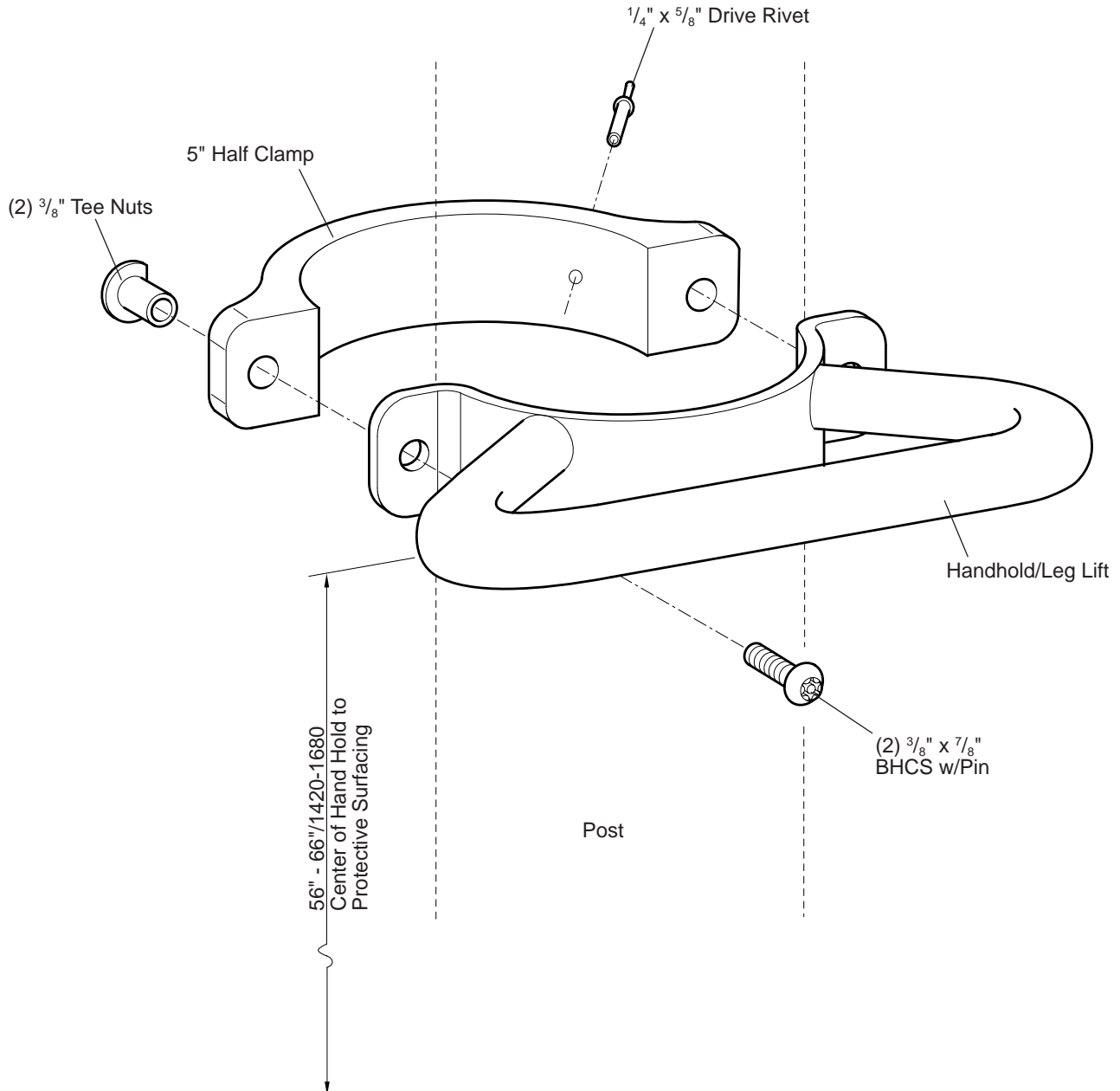



PlayBooster® 120902 Handhold/Leg Lift

Parts List

Part#	Description	Qty.
105327	5" Half Clamp, Specify Color	1
138029	Handhold/Leg Lift, Specify Color.....	1
106518	Hand Hold Hardware Package	1
100196	$\frac{3}{8}$ " x $\frac{7}{8}$ " BHCS w/Pin, SST	2
100351	$\frac{3}{8}$ " Tee Nut, SST.....	2
100610	$\frac{1}{4}$ " x $\frac{5}{8}$ " Drive Rivet, AL/SST	1

Specifications

Half Clamp: Cast aluminum. Finish: ProShield®, color specified.

Hand Hold: Weldment comprised of formed $\frac{7}{8}$ " O.D. 11 GA (.120") and $\frac{1}{4}$ " x $1\frac{3}{4}$ " stainless steel half clamps. Finish: TenderTuff™, color specified.

Fasteners: Primary fasteners shall be socketed and pinned tamperproof in design, stainless steel (SST) per ASTM F 879 unless otherwise indicated (see specific product installation/specifications).

Installation Time: Approx. $\frac{1}{4}$ man hour
Weight: 4 lbs.

Installation Instructions

- 1) Attach handhold/leglift to post at height shown, using a 5" half clamp, $\frac{3}{8}$ " x $\frac{7}{8}$ " BHCS w/pin and $\frac{3}{8}$ " tee nuts.
- 2) Install $\frac{1}{4}$ " x $\frac{5}{8}$ " drive rivet in 5" half clamp. Refer to the Offset Hanger Clamp Spec Sheet.
- 3) Install protective surfacing before users are allowed to play on the structure.

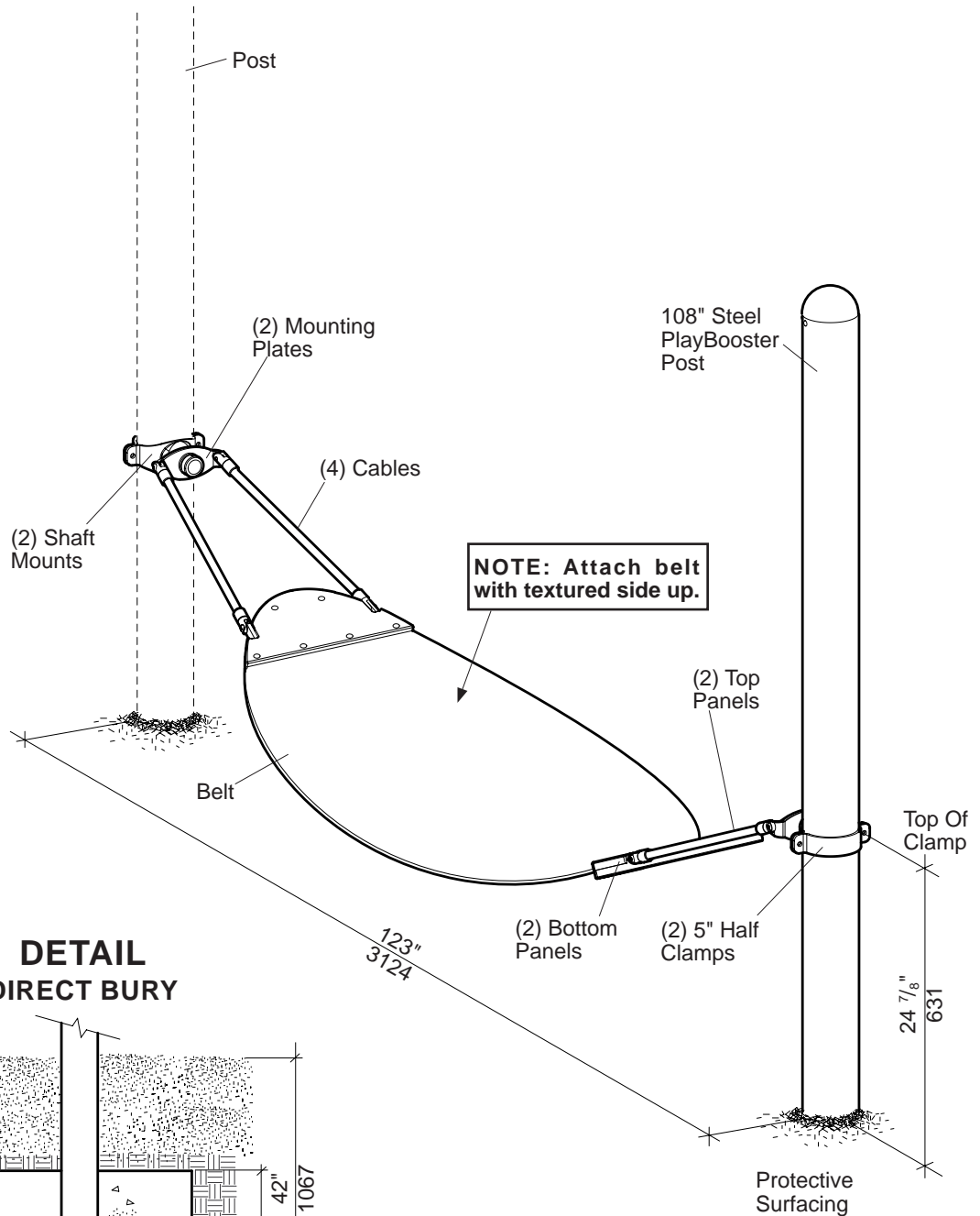

**DETAIL
DIRECT BURY**

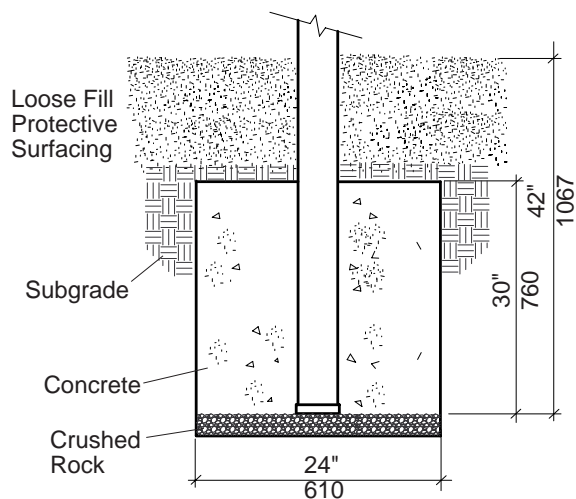

Parts List

Part#	Description	Qty.
100610	1/4" x 5/8" Drive Rivet, AL/SST	2
105327	5" Half Clamp, Specify Color	2
140619	108" Steel Post w/Cap, 42" DB, Specify Color.....	1
228417	Belt, Specify Color	1
194377	Belt Plate, Specify Color	2
194378	Top Panel, Specify Color.....	2
194379	Bottom Panel, Specify Color.....	2
198514	Mounting Plate, Specify Color.....	2
194381	Shaft Mount, Specify Color.....	2
195244	25" Cable, Black.....	4
196831	Presser Plate, Specify Color	2
212797	Boogie Board Hardware Package	1
100198	3/8" x 1 1/8" BHCS w/Pin, SST	4
113027	3/8" x 1 3/8" BHCS w/Pin, SST	12
100290	3/8" x 7/8" BHCS w/Pin Limited Thread, SST	8
100351	3/8" Tee Nut, SST.....	4
100353	3/8" Flange Nut w/Pin, SST.....	12
121135	1/4" O.D. x 2" Long Spring Pin, SST	2
127179	5/8" O.D. x 3/8" Bushing, SST.....	8
128296	3/8" Jam Nut, SST.....	4
120302	Collar, SST	2
149200	Thrust Bearing.....	2

Specifications

Post: See PlayBooster® (PB) General Specifications.

Mounting Plate: Weldment comprised of 3/8" (9,53 mm) thick SST, and 2" (50,8 mm) O.D. x 1.50" (38,1 mm) I.D. stainless steel housing. Finish: ProShield®, color specified. (Oilite Bronze Bearing) 1.500" (38,1 mm) O.D. x 1.257" (31,92 mm) I.D.

Shaft Mount: Weldment comprised of 1/4" (6,35 mm) thick HRPO flat steel and 1" (25 mm) diameter stainless steel shaft. Finish: ProShield®, color specified.

Belt Plate: Weldment comprised of 3/8" (9,53 mm) thick HRPO sheet steel and 1/4" (6,35 mm) thick HRPO sheet steel. Finish: ProShield®, color specified.

Presser Plate: Fabricated from 7 GA. (.179") (4,54 mm) thick HRPO sheet steel. Finish: ProShield®, color specified.

Cable Assembly: **(Cable)** Made of tightly woven polyester-wrapped, six-stranded galvanized-steel cable with a polypropylene core. **(Cable Connectors)** 6063-T6 aluminum.

Panels: Permalene®, color specified.

Belt: .315" (8,00 mm) Thick mini rough top rubber belting with polyester fabric plys, black in color.

Clamps: Cast Aluminum. Finish: ProShield®, color specified.

Fasteners: Primary fasteners shall be socketed and pinned tamperproof in design, stainless steel (SST) per ASTM F 879 unless otherwise indicated (see specific product installation/specifications).

Installation Time: Approx. 3 man hours

Weight: 110 lbs.

Concrete: Approx. 7.85 cu. ft.

Fall Height: 24" (0,61 m)

Installation Instructions

- 1) **(Direct Bury)** Dig footings to dimensions shown.
- 2) Attach shaft mounts to posts at height shown. Refer to the Shaft Mount Assembly Detail.
- 3) Slide mounting plate, thrust bearing, and collar onto shaft mount shaft. Line up hole in collar with hole in shaft. Tap 1/4" O.D. x 2" long spring pin through collar and shaft. Refer to the Shaft Mount Assembly Detail.
- 4) Attach belt plates, presser plates and panels to belt. Refer to the Belt Plate Attachment Detail.
- 5) Insert 5/8" O.D. x 3/8" long bushings into belt plate tabs. Attach cables to belt plate tabs. Refer to the Boogie Board Attachment Detail.
- 6) Insert 5/8" O.D. x 3/8" long bushings into mounting plate holes. Attach cables to mounting plates. Refer to the Cable Attachment Detail.
- 7) With post plumb, pour concrete footing. Allow concrete footings to cure for a minimum of 72 hours before users are allowed to play on the structure.
- 8) Install 1/4" x 5/8" drive rivets in 5" half clamps. Drill through hole in 5" half clamps and into 5" post with a 1/4" or "F" (only) drill bit, insert drive rivet in hole through clamp and into post. Hammer drive rivet pin in until flush with head. Refer to the Typical Offset Hanger Clamp Spec Sheet.
- 9) Install protective surfacing before users are allowed to play on the structure.

**DETAIL
SHAFT MOUNT ASSEMBLY**

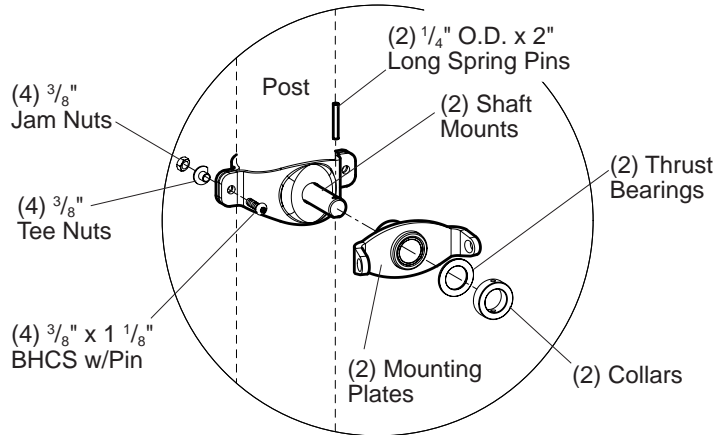

**DETAIL
CABLE ATTACHMENT**

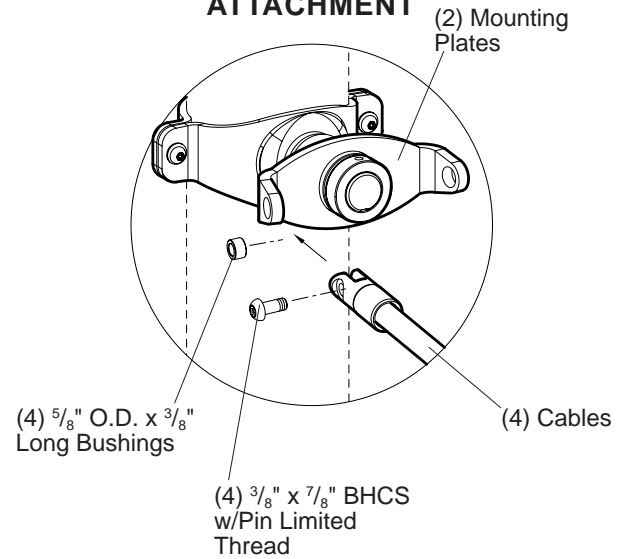

**DETAIL
BELT PLATE ATTACHMENT**

NOTE: Attach belt with textured side up.

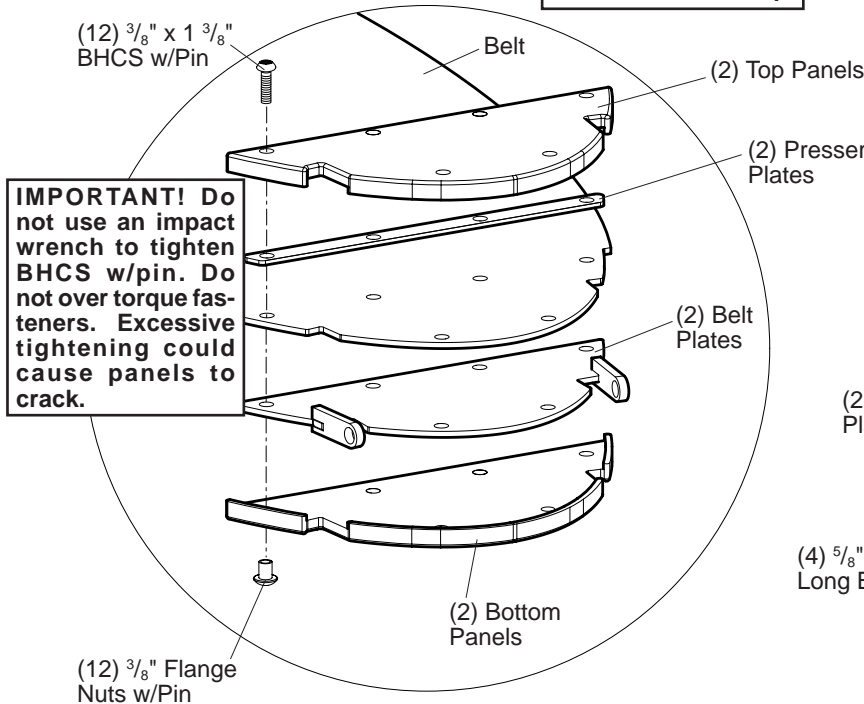

IMPORTANT! Do not use an impact wrench to tighten BHCS w/pin. Do not over torque fasteners. Excessive tightening could cause panels to crack.

**DETAIL
BOOGIE BOARD ATTACHMENT**

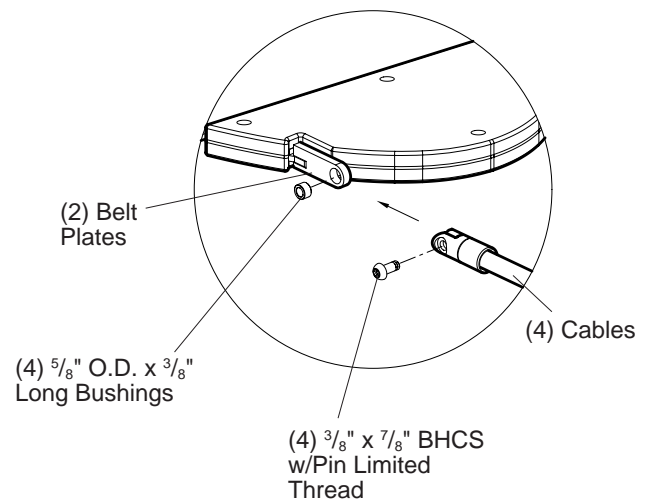

**DETAIL
SUPPORT ATTACHMENT**

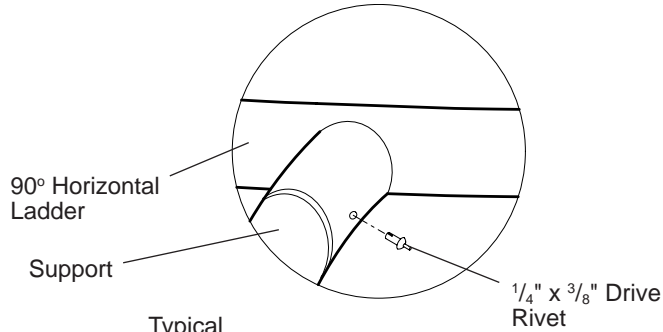

**DETAIL
BEAM ATTACHMENT**

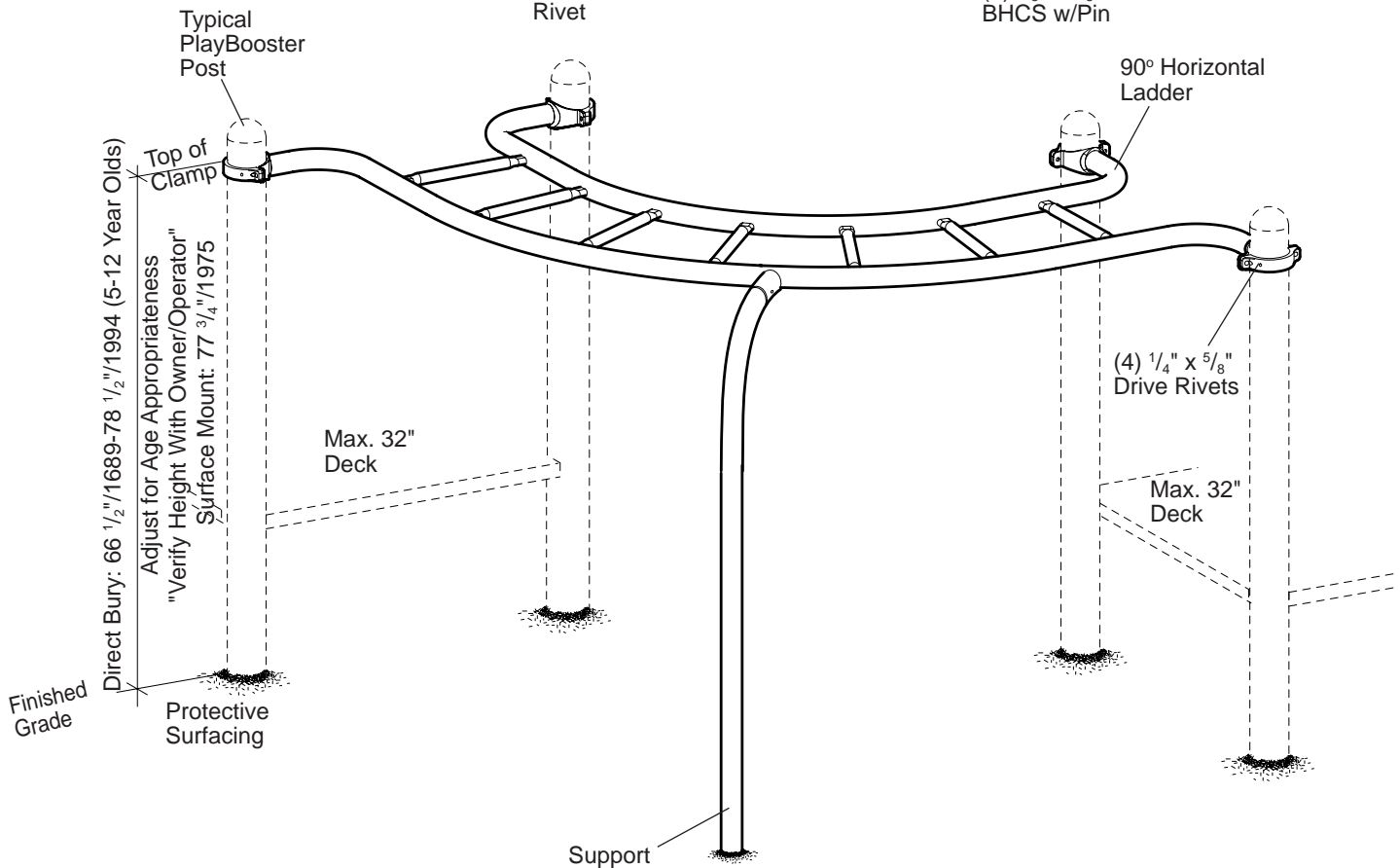
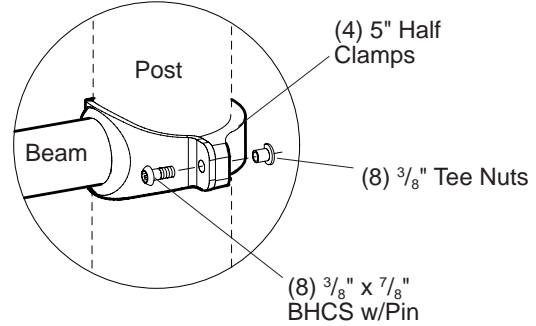



PlayBooster® 142890 Horizontal Ladder, 90°

Parts List

Part#	Description	Qty.
170164	90° Horizontal Ladder, Specify Color	1
170165	Support (DB), Specify Color	1
170166	Support (SM), Specify Color	1
105327	5" Half Clamp, Specify Color	4
100610	1/4" x 5/8" Drive Rivet, AL/SST	4
111392	2 Hole (SM) Hardware Package	1
100266	1/2" x 2 3/4" Expansion Anchor	2
100322	1/2" Standard Hex Nut, SST	2
100363	1/2" Flat Washer, SST	2
171074	Horizontal Ladder, Hardware Package	1
100196	3/8" x 7/8" BHCS w/Pin, SST	8
100351	3/8" Tee Nut, SST	8
100611	1/4" x 3/8" Drive Rivet, AL/SST	1

DB = Direct Bury

SM = Surface Mount

Specifications

90° Horiz. Ladder: Weldment comprised of 2.375" O.D. RS-40 (.130"-.140") galvanized steel tubing, 1.315 O.D. RS-20 (.080"-.090") galvanized steel tubing and 1/4" HRPO flat steel. Finish: ProShield®, color specified.

Support: Weldment comprised of 2.375" O.D. RS-20 (.095"-.105") galvanized steel tubing. Finish: ProShield color specified.

Clamp: Cast aluminum. Finish: ProShield color specified.

Fasteners: Primary fasteners shall be socketed and pinned tamperproof in design, stainless steel (SST) per ASTM F 879 unless otherwise indicated (see specific product installation/specifications).

Installation Time: Approx. 2 man hours

Concrete Req.: 33" Bury - Approx. 1.31 cu. ft.

44 3/4" Bury - Approx. 2.18 cu. ft.

Area Req.: 6' (1,83 m) minimum use zone

Weight: DB = 114 lbs.

SM = 110 lbs.

Max. Fall Height: 67"-79" (1,70 m - 2,01 m) 5-12 Yr. Olds.

Installation Instructions

Direct Bury

- 1) Dig footing to depth and spacing as shown.
- 2) Mark posts for the appropriate height of the ladder you are installing.
- 3) Lift ladder into position and attach to posts using 5" half clamps with 3/8" x 7/8" BHCS w/pin and 3/8" tee nuts. Refer to the Beam Attachment Detail.
- 4) Insert support into ladder sleeve. With support plumb, drill through sleeve and support using a 1/4" or "F"(only) drill bit. Insert 1/4" x 3/8" drive rivet into hole, and hammer rivet pin in until it is flush with head. Refer to the Support Attachment Detail.
- 5) Be sure ladder is level, if not adjust clamps to do so.
- 6) Install 1/4" x 5/8" drive rivets in all 5" half clamps. Refer To The Typical Offset Hanger Clamp Spec Sheet.
- 7) Plumb support and pour concrete footing. Allow concrete footings to cure a minimum of 72 hours before users are allowed to play on the structure.
- 8) Install protective surfacing before users are allowed to play on the structure.

Surface Mount

- 1) Mark posts for the appropriate height of the ladder you are installing.
- 2) Lift ladder into position and attach to posts using 5" half clamps with 3/8" x 7/8" BHCS w/pin and 3/8" tee nuts. Refer to the Beam Attachment Detail.
- 3) Insert support into ladder sleeve. With support plumb, drill through sleeve and support using a 1/4" or "F"(only) drill bit. Insert 1/4" x 3/8" drive rivet into hole, and hammer rivet pin in until it is flush with head. Refer to the Support Attachment Detail.
- 4) Be sure ladder is level, if not adjust clamps to do so.
- 5) Using a hammer drill and 1/2" masonry bit, drill anchor bolt holes into concrete slab 3" deep through holes in support plate, as shown.
- 6) Tap expansion anchors into holes and fasten using 1/2" flat washers and 1/2" standard hex nuts, as shown.
- 7) Install 1/4" x 5/8" drive rivets in all 5" half clamps. Refer To The Typical Offset Hanger Clamp Spec Sheet.
- 8) Install protective surfacing before users are allowed to play on the structure.

PLAN VIEW FOOTING LAYOUT

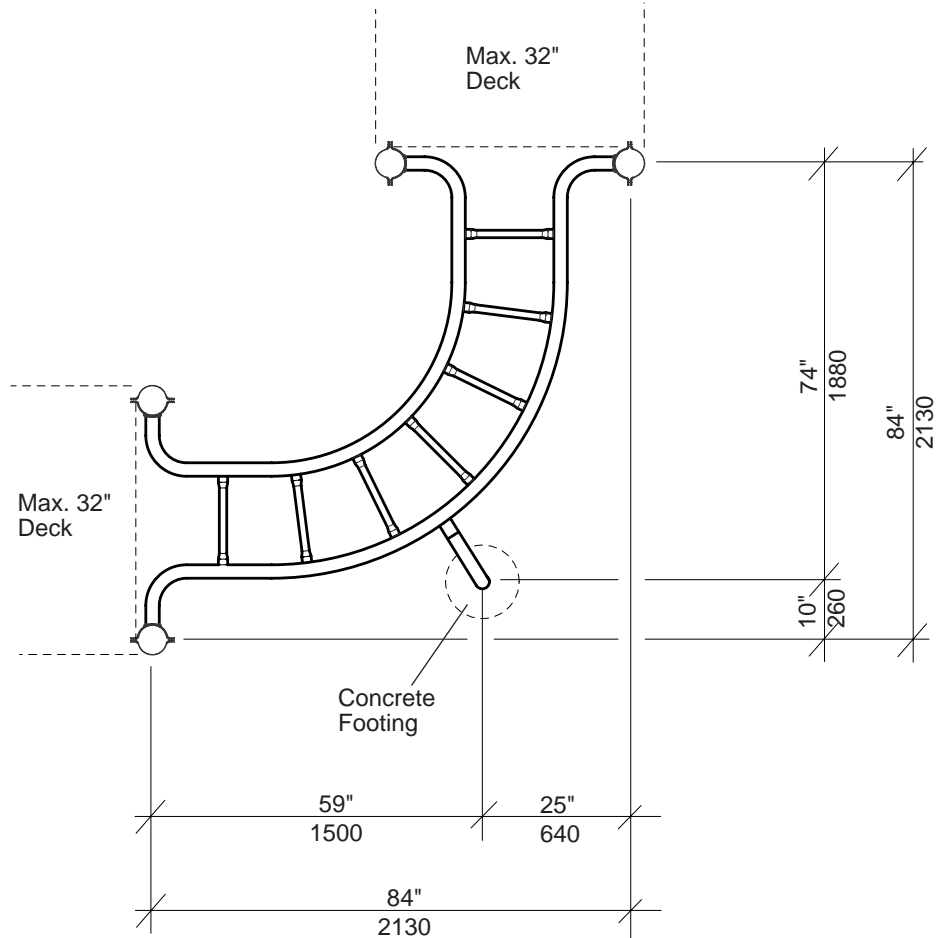

DETAIL SURFACE MOUNT

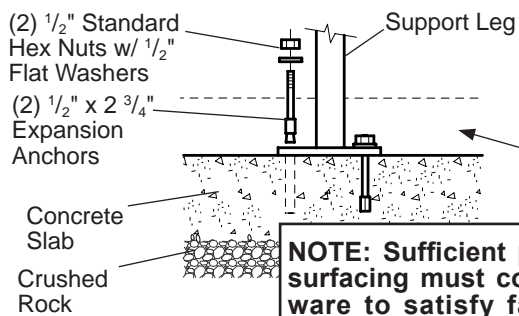

NOTE: Sufficient protective surfacing must cover hardware to satisfy fall height requirements.

DETAIL DIRECT BURY

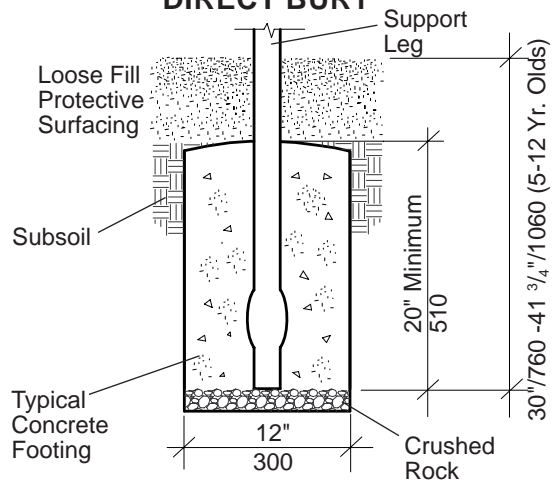

**PLAN VIEW/
FOOTING LAYOUT**

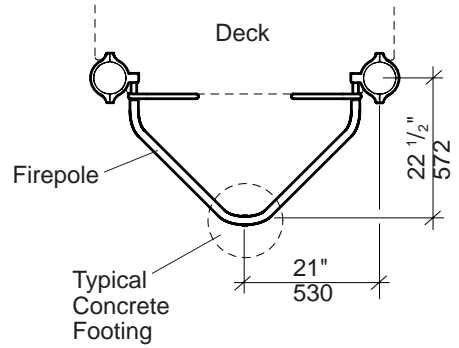

**DETAIL
HANDHOLD PANEL ATTACHMENT**

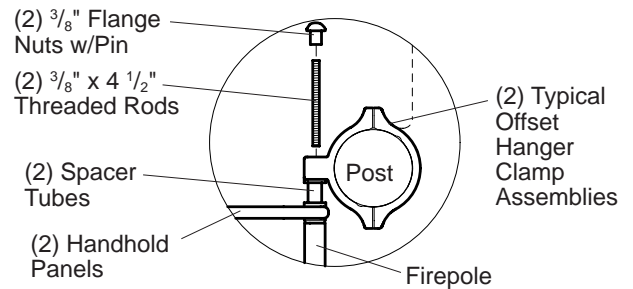

**DETAIL
SURFACE MOUNT**

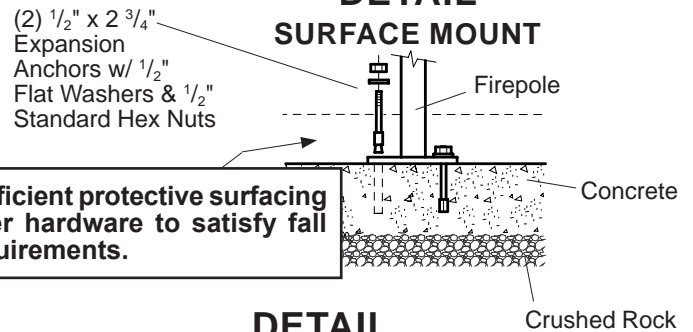

NOTE: Sufficient protective surfacing must cover hardware to satisfy fall height requirements.

**DETAIL
DIRECT BURY**

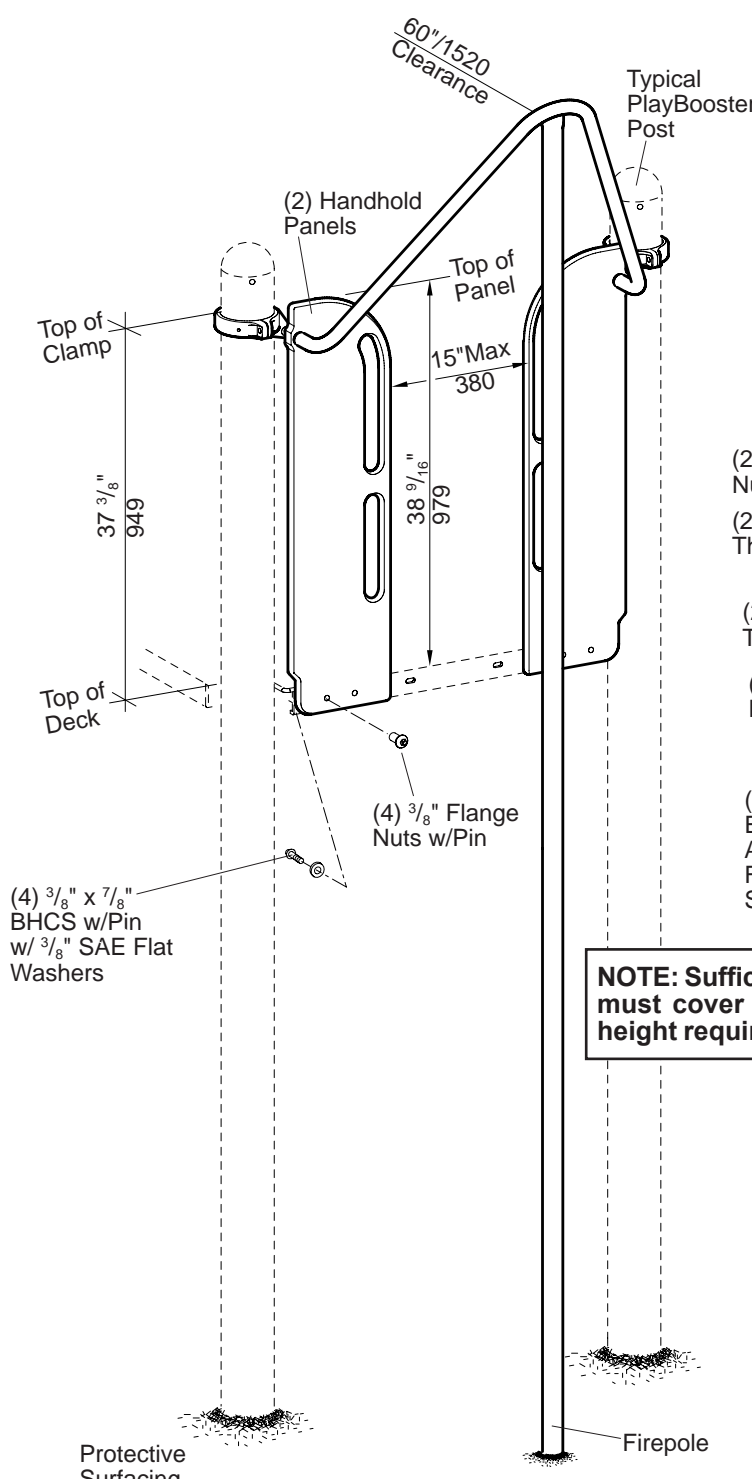
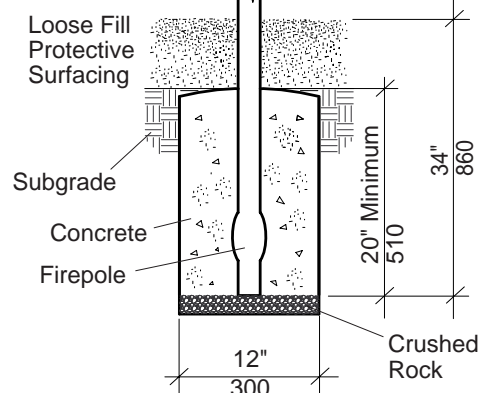

72" Deck Height Shown

PlayBooster® 148426 Firepoles, 32"-72" Decks

Parts List

Part#	Description	Qty.
147954	Handhold Panel, Specify Color	2
105327	5" Half Clamp, Specify Color	2
113729	Offset Hanger Clamp, Specify Color	2
147956	Firepole, 32" Deck (DB), Specify Color	1
147957	Firepole, 40" Deck (DB), Specify Color	1
147958	Firepole, 48" Deck (DB), Specify Color	1
147959	Firepole, 56" Deck (DB), Specify Color	1
147960	Firepole, 64" Deck (DB), Specify Color	1
147961	Firepole, 72" Deck (DB), Specify Color	1
147962	Firepole, 32" Deck (SM), Specify Color	1
147963	Firepole, 40" Deck (SM), Specify Color	1
147964	Firepole, 48" Deck (SM), Specify Color	1
147965	Firepole, 56" Deck (SM), Specify Color	1
147966	Firepole, 64" Deck (SM), Specify Color	1
147967	Firepole, 72" Deck (SM), Specify Color	1
113468	7/8" O.D. x 1 11/16" Spacer Tube, Specify Color	2
100610	1/4" x 5/8" Drive Rivet, AL/SST	2
148176	Pole Hardware Package	1
100196	3/8" x 7/8" BHCS w/Pin, SST	4
100198	3/8" x 1 1/8" BHCS w/Pin, SST	4
100351	3/8" Tee Nut, SST	4
100353	3/8" Flange Nut w/Pin, SST	6
100365	3/8" SAE Flat Washer, SST	4
148081	3/8" x 4 1/2" Threaded Rod, SST	2
111392	2-Hole (SM) Hardware Package	1
100266	1/2" x 2 3/4" Expansion Anchors	2
100322	1/2" Standard Hex Nut, SST	2
100363	1/2" Flat Washer, SST	2

DB = Direct Bury
SM = Surface Mount

Specifications

Firepole: Weldment comprised of 1.900" O.D. RS20 (.090" - .100") galvanized steel tubing, and 1.315" O.D. RS20 (.080" - .090") galvanized steel tubing. Finish: ProShield®, color specified.

Handhold Panel: Solid color Permalene®, color specified.

Clamps: Cast aluminum. Finish: ProShield, color specified.

Fasteners: Primary fasteners shall be socketed and pinned tamperproof in design, stainless steel (SST) per ASTM F 879 unless otherwise indicated (see specific product installation/specifications).

Installation Time: **SM** - Approx. 1 1/2 man hours
DB - Approx. 2 man hours

Concrete Req.: Approx. 1.3 cu. ft.
Weight: 55 lbs. (32"-48" Deck)
59 lbs. (56"-72" Deck)

Fall Height: Deck Height

Installation Instructions

- 1) **(Direct Bury)** Dig footing hole as shown. Refer to the Plan View/Footing Layout.
- 2) Attach offset hanger clamps to posts at heights shown using 5" half clamps, 3/8" x 1 1/8" BHCS w/pin and 3/8" tee nuts. Refer to the Typical Offset Hanger Clamp Spec Sheet.
- 3) Attach handhold panels to the face of the deck using 3/8" x 7/8" BHCS w/pin with 3/8" SAE flat washers and 3/8" flange nuts w/pin.
- 4) Attach firepole to handhold panels and offset hanger clamps using 3/8" flange nuts w/pin, 3/8" x 4 1/2" threaded rods and spacer tubes. Refer to the Handhold Panel Attachment Detail. **NOTE:** Turn 3/8" x 4 1/2" threaded rod into 3/8" flange nut w/pin until it bottoms out, before attaching firepole.
- 5) **(Direct Bury)** With firepole plumb, pour concrete footing. Allow concrete footing to cure a minimum of 72 hours before users are allowed to play on the structure.
(Surface Mount) Drill 1/2" x 3" deep holes through support plate using hammer drill and 1/2" masonry bit. Tap expansion anchors into drilled holes. Fasten support plates to expansion anchors using 1/2" standard hex nuts with 1/2" flat washers.
- 6) Install protective surfacing before users are allowed to play on the structure.

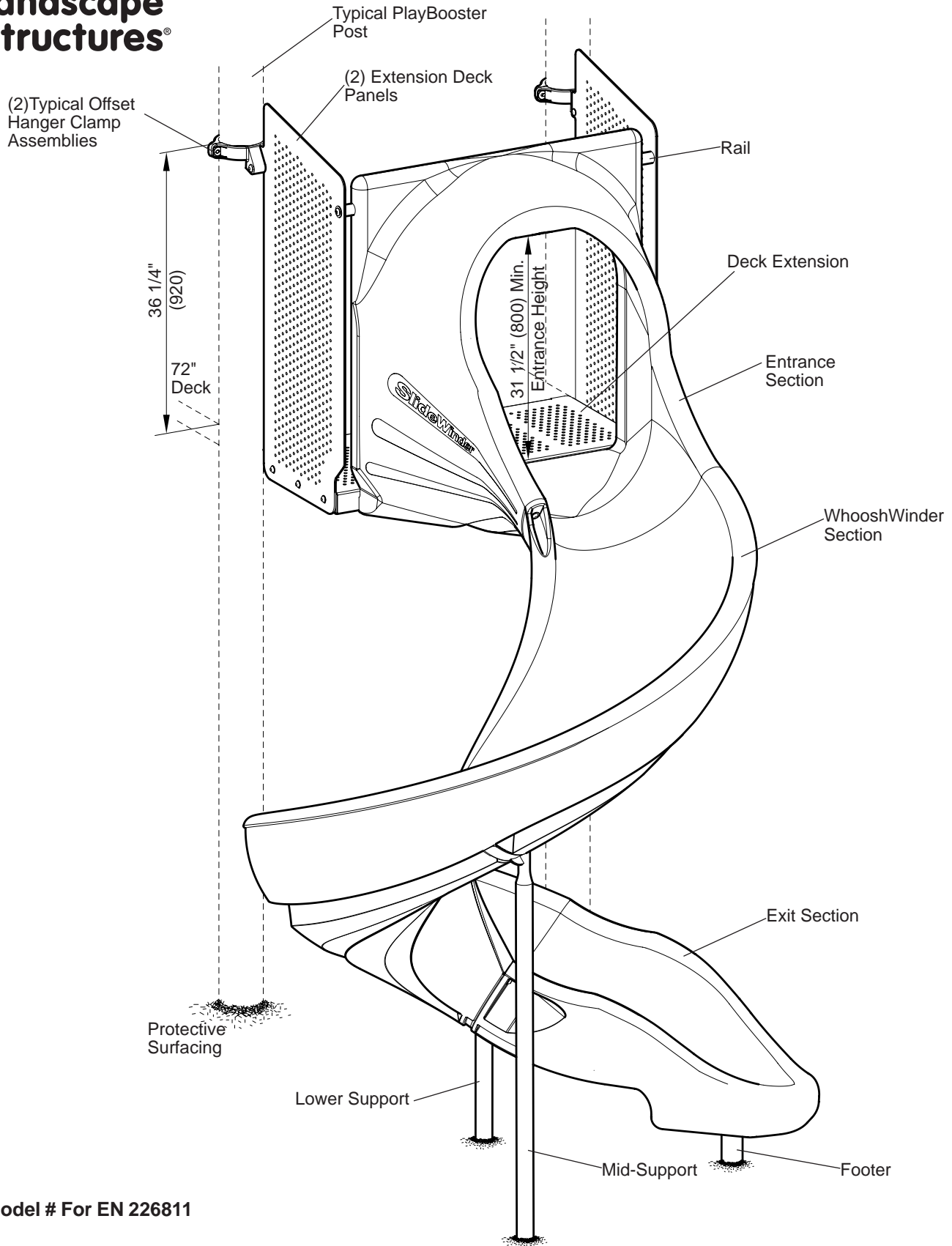

Model # For EN 226811

PlayBooster® 222708 WhooshWinder™, 72" Deck

Sheet 1 of 7

PLAN VIEW/FOOTING LAYOUT

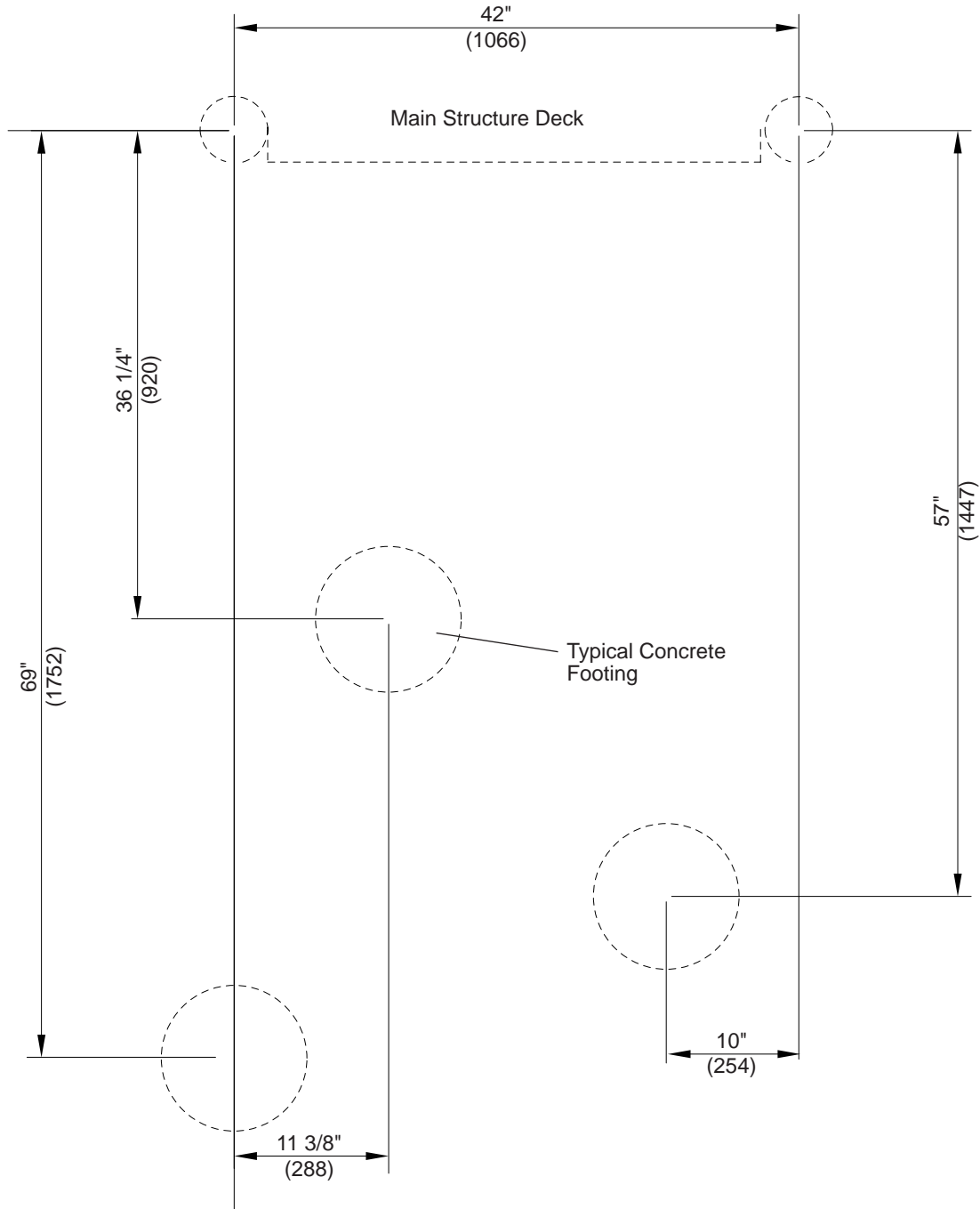

DETAIL
BOTTOM VIEW WITHOUT EXIT SECTION

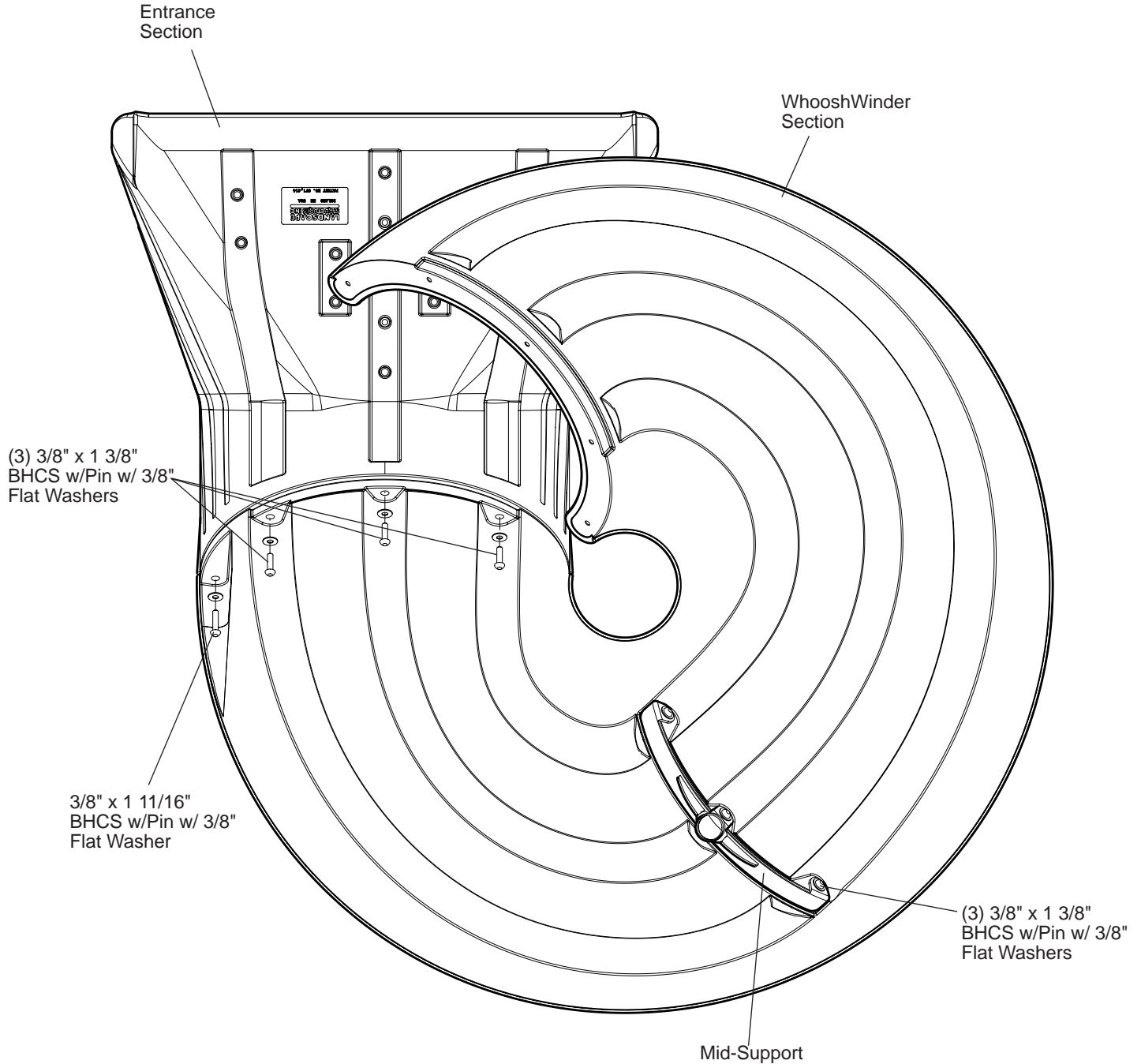

DETAIL
LOWER SUPPORT & FOOTER ATTACHMENT
(BOTTOM VIEW)

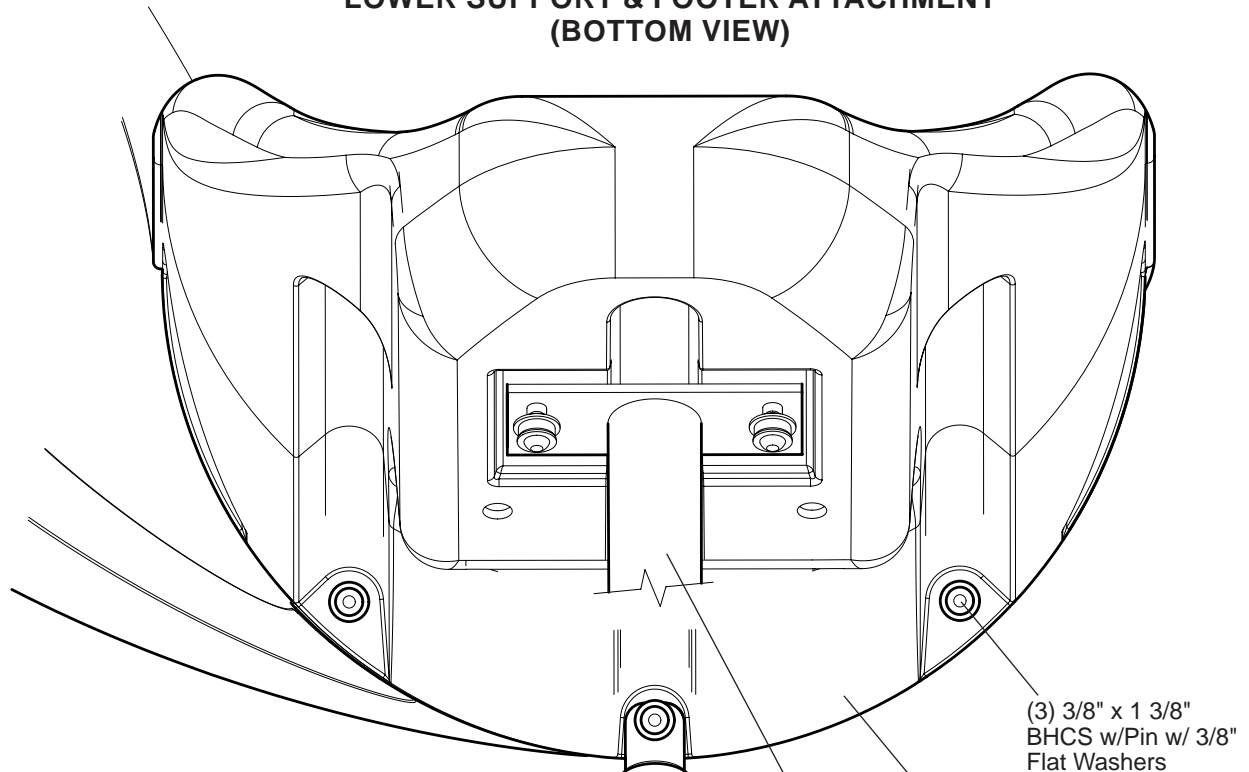

DETAIL
FOOTER ATTACHMENT

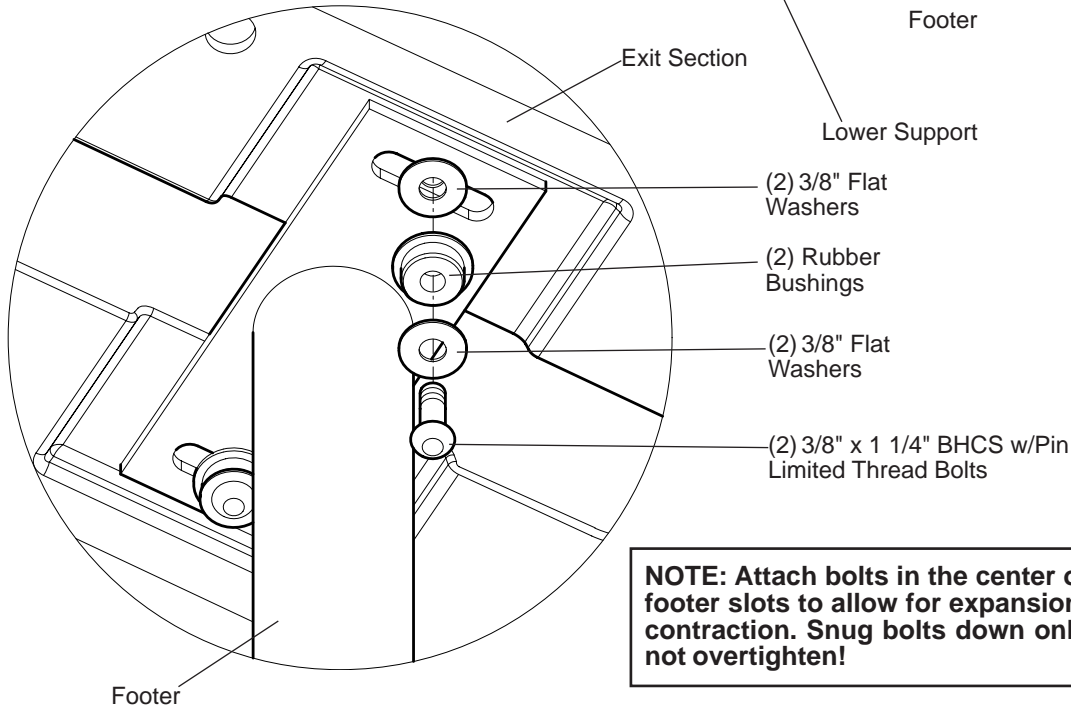

NOTE: Attach bolts in the center of the footer slots to allow for expansion and contraction. Snug bolts down only, do not overtighten!

DETAIL
EXTENSION PANEL ATTACHMENT

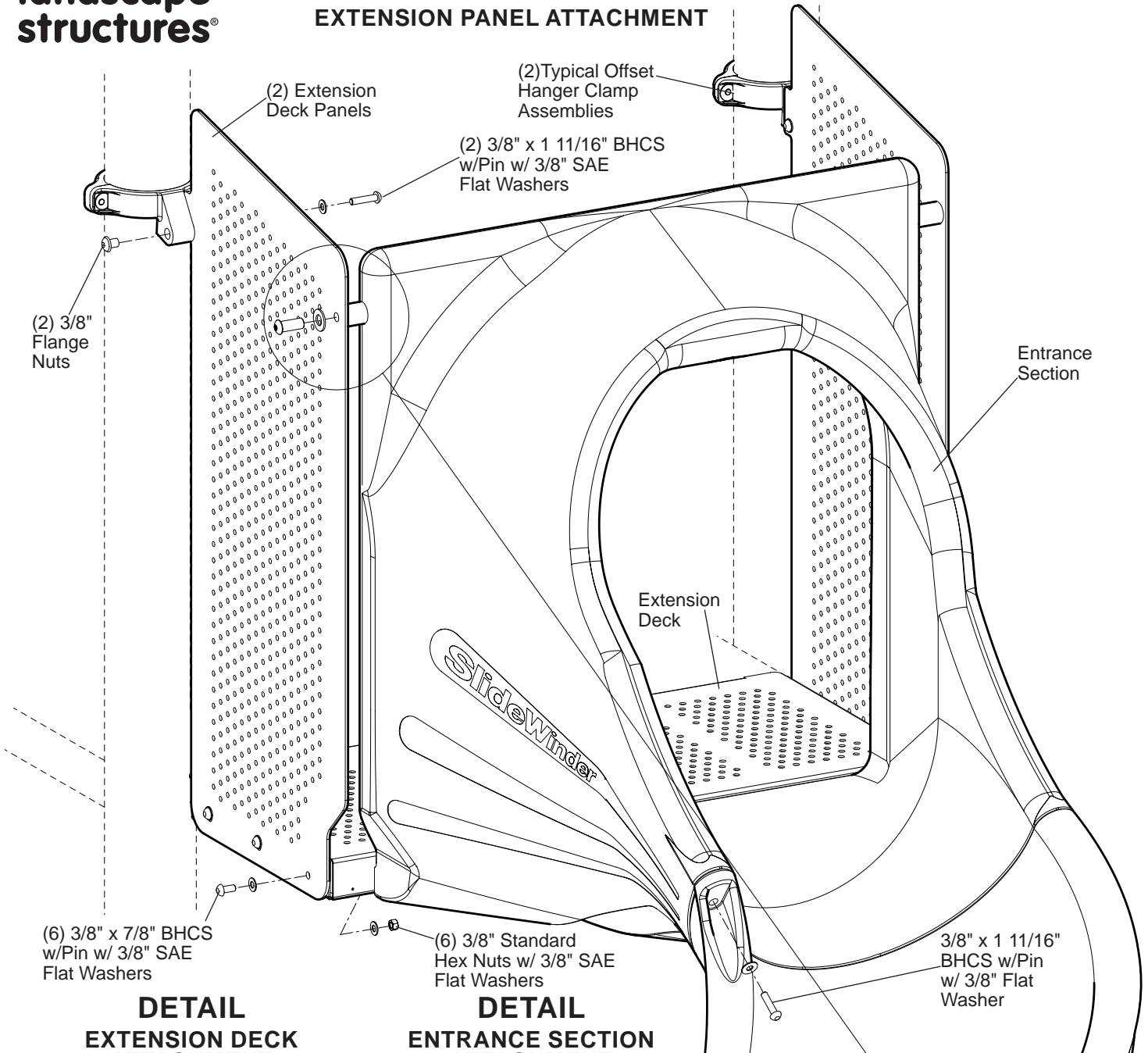

DETAIL
EXTENSION DECK ATTACHMENT

DETAIL
ENTRANCE SECTION ATTACHMENT

DETAIL

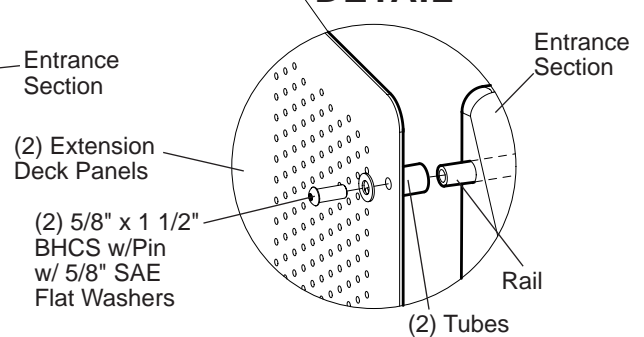
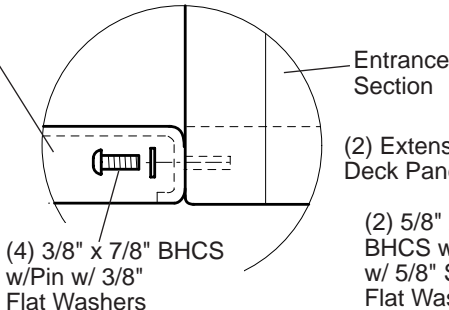
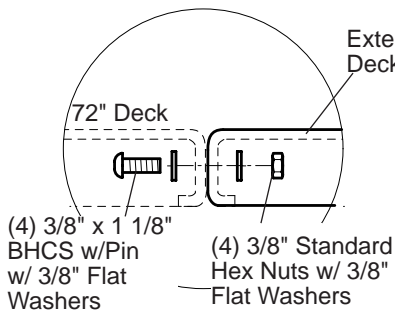

**DETAIL
DIRECT BURY**

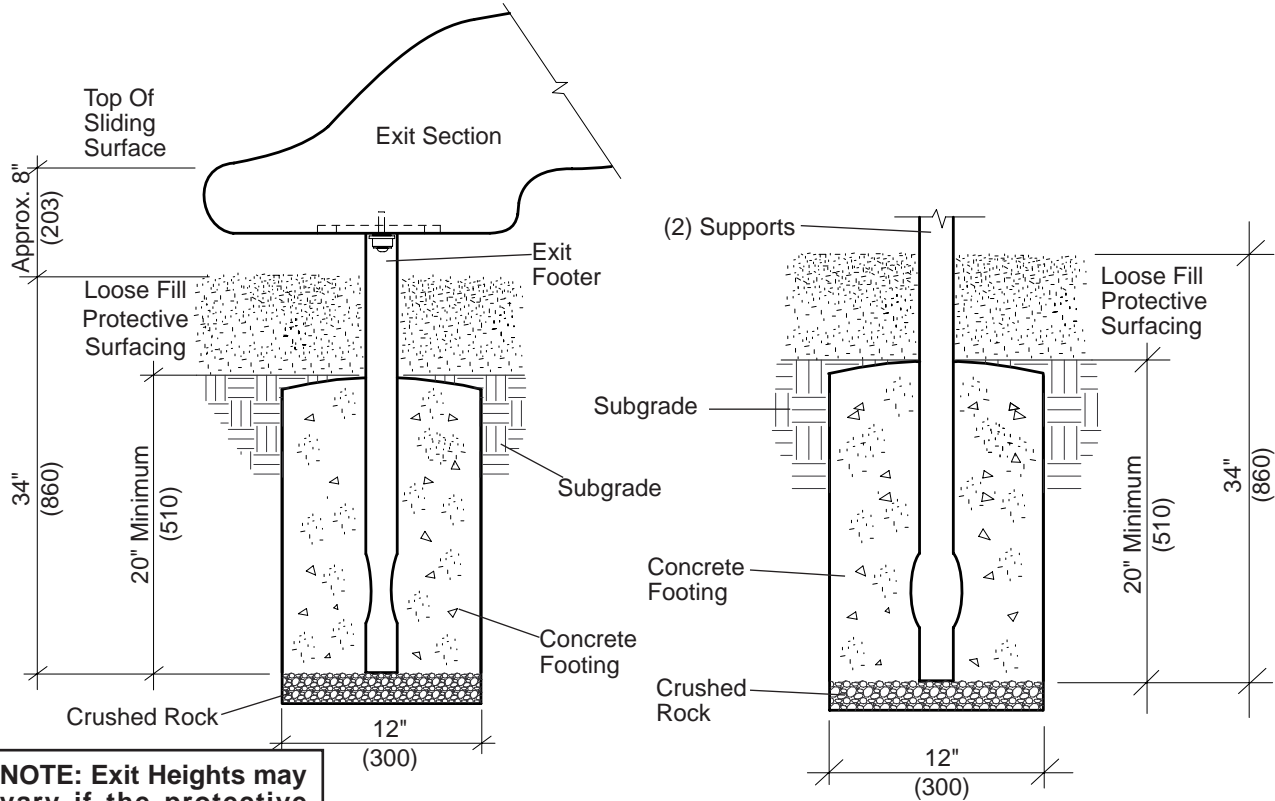

NOTE: Exit Heights may vary if the protective surfacing is not level. Do not put pressure/tension on the entrance section when adjusting the exit height.

**DETAIL
SURFACE MOUNT**

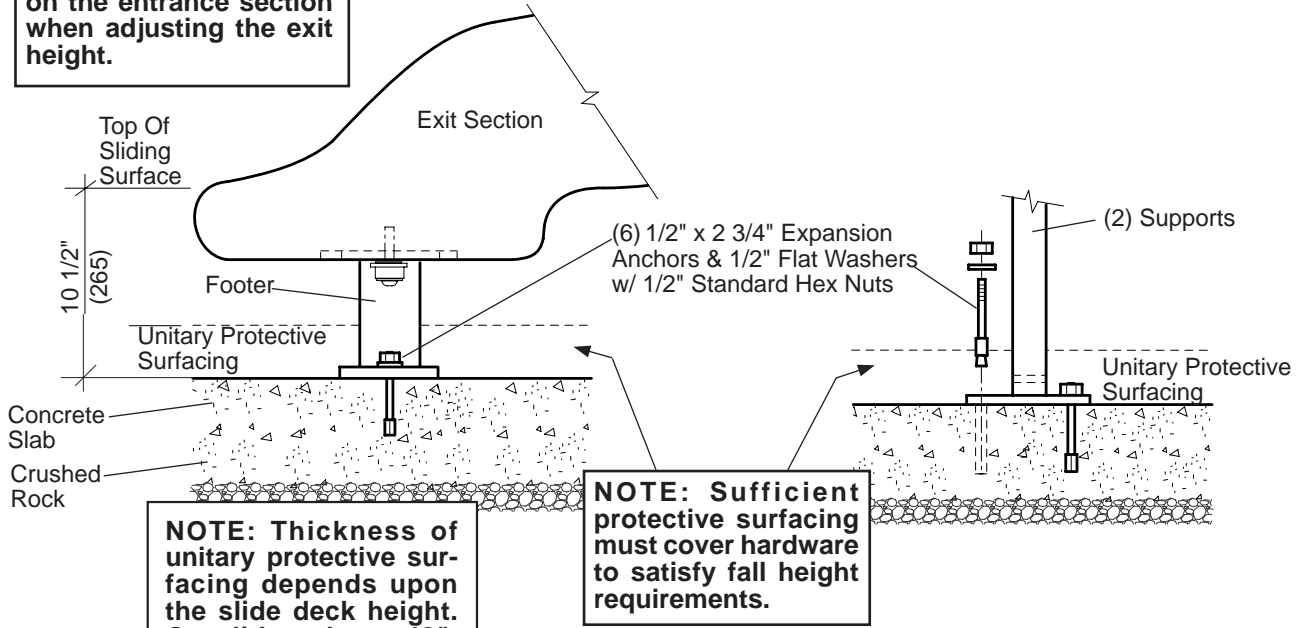

NOTE: Thickness of unitary protective surfacing depends upon the slide deck height. On slides above 48". The exit height shall be 7" minimum.

NOTE: Sufficient protective surfacing must cover hardware to satisfy fall height requirements.



PlayBooster® 222708 WhooshWinder™, 72" Deck

Parts List

Part#	Description	Qty.
100583	40 7/16" Rail, Specify Color	1
100610	1/4" x 5/8" Drive Rivet, AL/SST	2
105327	5" Half Clamp, Specify Color	2
113729	Offset Hanger Clamp, Specify Color	2
124876	Entrance Section, Specify Color	1
124877	Exit Section, Specify Color	1
128261	Exit Footer (DB), Specify Color	1
128262	Exit Footer (SM), Specify Color	1
132443	Spacer Tube, Specify Color	2
221442	WhooshWinder Section, Specify Color	1
221939	Mid-Support (DB), Specify Color	1
222222	Mid-Support (SM), Specify Color	1
222683	Deck Extension, Specify Color	1
222694	Extension Panel, Specify Color	2
225584	Lower Support (DB), Specify Color	1
221938	Lower Support (SM), Specify Color	1
223506	WhooshWinder 72" Deck Hardware Package	1
100196	3/8" x 7/8" BHCS w/Pin, SST	10
100198	3/8" x 1 1/8" BHCS w/Pin, SST	8
100362	3/8" Flat Washer, SST	29
100365	3/8" SAE Flat Washer, SST	14
100351	3/8" Tee Nut, SST	4
100353	3/8" Flange Nut w/Pin, SST	2
123224	3/8" x 1 11/16" BHCS w/Pin, SST	6
100201	5/8" x 1 1/2" BHCS w/Pin, SST	2
129500	5/8" SAE Flat Washer, SST	2
100327	3/8" Standard Hex Nut, SST	10
113027	3/8" x 1 3/8" BHCS w/Pin, SST	9
111442	#871 Rubber Bushing	2
100292	3/8" x 1 1/4" BHCS w/Pin Limited Thread, SST	2
111392	Exit Support Hardware Package (SM)	3
100266	1/2" x 2 3/4" Expansion Anchor	6
100322	1/2" Standard Hex Nut, SST	6
100363	1/2" Flat Washer, SST	6

DB = Direct Bury
SM = Surface Mount

Specifications

Slide Sections:	Rotationally molded from U.V. stabilized linear low density polyethylene, color specified.
Deck Extension:	Weldment comprised of 12 GA. (.105") (2.66 mm) HRPO sheet steel. Finish: Tender-Tuff coated, color specified.
Dk. Ext. Panel:	7 GA. (.179") (4,54 mm) HRPO flat steel. Finish: ProShield®, color specified.
Rail:	1 1/8" (28,57 mm) O.D. 6005-T5 aluminum extrusion with 5/16" (7,92 mm) walls. Finish: ProShield®, color specified.
Mid-Support:	Weldment comprised of 1.900" (48,26 mm) O.D. RS20 (.090"-.100") (2,28 mm - 2,54 mm) galvanized steel tubing and 3/16" (4,74 mm) x 1 1/4" (31,75 mm) zinc plated steel strap. Finish: ProShield, color specified.
Lower Support:	Weldment comprised of 1.900" (48,26 mm) O.D. RS20 (.090"-.100") (2,28 mm - 2,54 mm) galvanized steel tubing and 1/4" (6,35 mm) flat steel. Finish: ProShield, color specified.
Spacer Tube:	Fabricated from 1.312" (33,33 mm) O.D. x 16 Ga. (.065") (1,65 mm) steel tubing. Finish: ProShield, color specified.
Exit Footer:	Weldment comprised of 2.375" (60,32 mm) O.D. RS20 (.095"-.105") (2,41 mm-2,66 mm) galvanized steel tubing and 1/4" (6,35 mm) x 3" (76,2 mm) x 7 1/2" (190,5 mm) mounting plate. Finish: ProShield, color specified.
Offset Hanger Clamp Assy.:	Cast aluminum. Finish: ProShield, color specified.
Fasteners:	Primary fasteners shall be socketed and pinned tamperproof in design, stainless steel (SST) per ASTM F 879 unless otherwise indicated (see specific product installation/specifications).

Installation Time: 72" w/Extension Deck Approx. 5 labor hours
Concrete Req.: DB Approx. 3.93 cu. ft.
Weight: DB 346 lbs.
 SM 335 lbs.
Fall Height: Deck Height
Area Req: 6' (1,82 m) minimum use zone at exit.

Installation Instructions

- 1) Refer to the Plan View/Footing Location for location of footings.
- 2) **(Direct Bury)** Dig footing holes as shown. Refer to the Direct Bury Detail.
- 3) Attach offset hanger clamp assemblies to posts, at height shown. Refer to the Typical Offset Hanger Clamp Spec Sheet.
- 4) Attach deck extension to main structure deck.
- 5) Attach deck extension panels to extension deck and offset hanger clamp assemblies.
- 6) Place 40 7/16" rail in entrance section, and place spacer tubes over each end of the rail. Refer to Detail.
- 7) Fasten WhooshWinder section to entrance section together loosely starting in the inside and working your way to the outside. When all bolts are started, pull the tops flush with each other and tighten.
- 8) Attach mid-support to WhooshWinder section.
- 9) Attach exit footer to exit section. Attach lower support to exit section and WhooshWinder section. **NOTE:** Attach bolts in the center of the slots to allow for expansion and contraction. Snug bolts down only, do not overtighten. Refer to the Footer Attachment Detail.
- 10) With SlideWinder fully assembled, attach entrance section to the face of the deck extension. Refer to Entrance Section Attachment Detail.
- 11) Attach rail to deck extension panels.
- 12) **(Direct Bury)** With supports plumb pour concrete footings. Allow concrete footings to cure for a minimum of 72 hours before users are allowed to play on the structure.

(Surface Mount) Mark anchor bolt locations on concrete slab through holes in anchor plates. Drill 1/2" x 3" deep holes on marks into concrete using a hammer drill and 1/2" masonry bit. Tap 1/2" x 2 3/4" expansion anchors into drilled holes and fasten using 1/2" standard hex nuts with 1/2" flat washers.

- 13) Install 1/4" x 5/8" drive rivets in all 5" half clamps. Refer to the Typical Offset Hanger Clamp Spec Sheet.
- 14) Install protective surfacing before users are allowed to play on the structure.

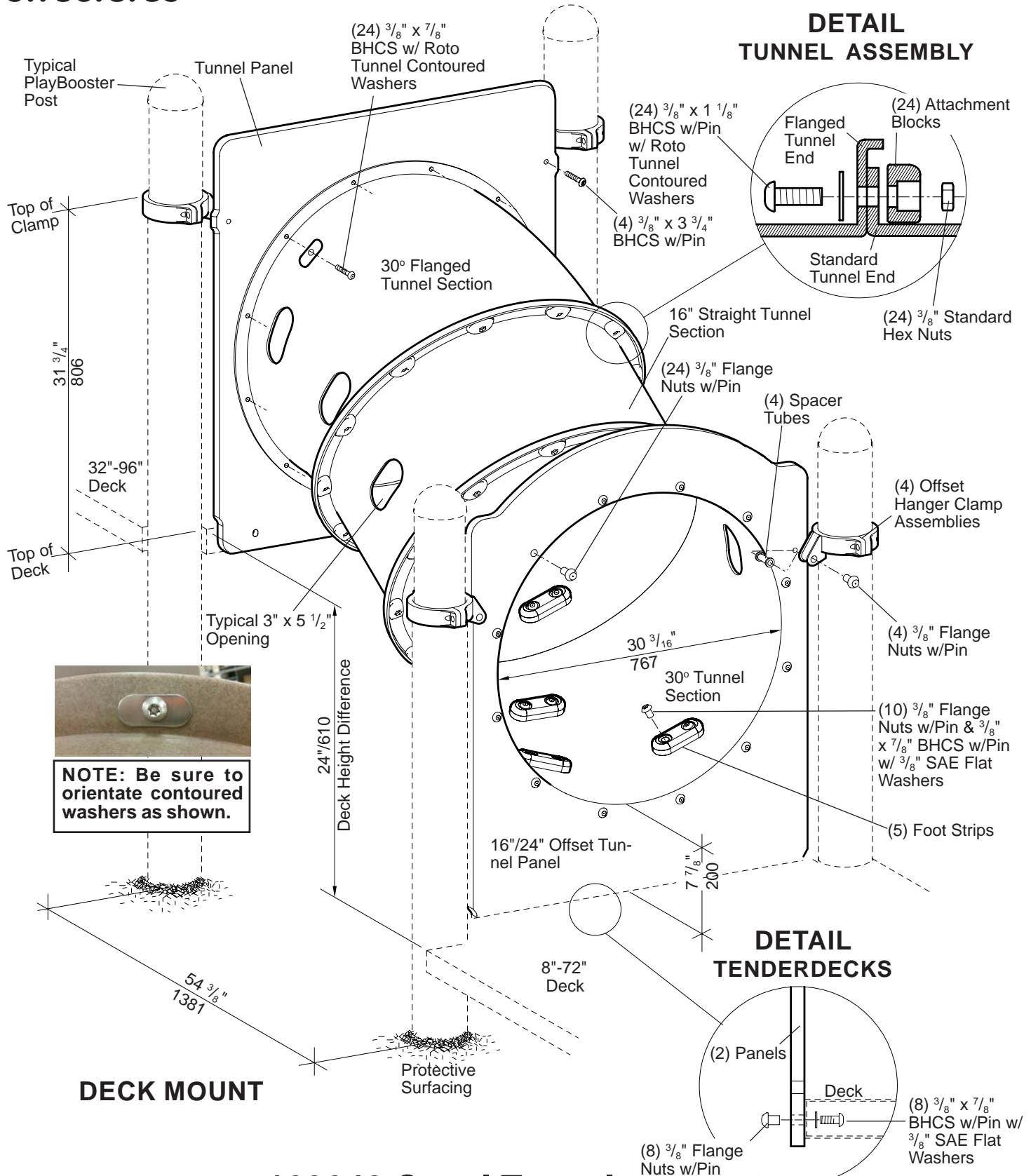

NOTE: Be sure to orientate contoured washers as shown.

DECK MOUNT

DETAIL TENDERDECKS

Parts List

Part#	Description	Qty.
DECK TO DECK		
116580	Tunnel Panel, Specify Color.....	1
122443	Tunnel Panel 16"/24" Offset, Specify Color	1
145617	16" Straight Section w/Slots, Specify Color	1
119602	30° Tunnel Section Flanged w/Slots, Specify Color.....	1
145600	30° Elbow Section w/Slots, Specify Color	1
145622	Foot Strip, Green w/Black.....	5
105327	5" Half Clamp, Specify Color	4
113729	Offset Hanger Clamp, Specify Color	4
113468	Spacer Tube, Specify Color.....	4
100610	1/4" x 5/8" Drive Rivet, AL/SST.....	4
133047	Attachment Block, Specify Color.....	24
223493	Offset Tunnel 24" Hardware Package	1
100196	3/8" x 7/8" BHCS w/Pin, SST	34
100198	3/8" x 1 1/8" BHCS w/Pin, SST	24
100327	3/8" Standard Hex Nut, SST	24
100353	3/8" Flange Nut w/Pin, SST.....	34
100365	3/8" SAE Flat Washer, SST.....	10
216834	Roto Tunnel Contoured Washer, SST.....	48
124900	Tenderdeck Mounting Hardware Package	2
100196	3/8" x 7/8" BHCS w/Pin, SST	8
100198	3/8" x 1 1/8" BHCS w/Pin, SST	8
100351	3/8" Tee Nut, SST.....	8
100353	3/8" Flange Nut w/Pin, SST.....	12
100365	3/8" SAE Flat Washer, SST.....	8
124460	3/8" x 3 3/4" BHCS w/Pin, SST	4
FOR GROUND LEVEL, ADD:		
105327	5" Half Clamp, Specify Color	2
113729	Offset Hanger Clamp, Specify Color	2
113464	Angled Panel Bracket, Specify Color.....	1
124947	Ground Level Mounting Hardware Package	1
124460	3/8" x 3 3/4" BHCS w/Pin, SST	2
100195	3/8" x 5/8" BHCS w/Pin, SST	4
100198	3/8" x 1 1/8" BHCS w/Pin, SST	8
100203	5/8" x 2 1/4" BHCS w/Pin, SST	2
100351	3/8" Tee Nut, SST.....	8
100353	3/8" Flange Nut w/Pin, SST.....	6
100610	1/4" x 5/8" Drive Rivet, AL/SST.....	4

Specifications

Permalene® Panel:	Solid color panel measures 35 5/8" wide x 41" high, & 35 3/8" wide x 47 7/8" high, color specified.
Angled Panel Brkt:	Weldment comprised of .190" thick 5052 aluminum formed angle with (2) 6061-T6 aluminum threaded tubes 1 1/8" O.D. x 1 1/2" long. Finish: ProShield®, color specified.
Foot Strip:	Recycled Permalene, color specified.
Tunnel Section:	Rotationally molded from U.V. stabilized linear low density polyethylene, color specified.
Attachment Block:	U.V. stabilized high-density polyethylene, color specified.
Spacer Tube:	Made from 6061-T6 aluminum 7/8" O.D. x 1 11/16". Finish: ProShield, color specified.
Offset Hanger Clamp Assembly:	Cast aluminum. Finish: ProShield, color specified.
Fasteners:	Primary fasteners shall be socketed and pinned tamperproof in design, stainless steel (SST) per ASTM F 879 unless otherwise indicated (see specific product installation/specifications).

Installation Time:	Approx. 2 1/2 man hours Deck To Deck Approx. 3 1/2 man hours Deck To Ground
Min. Use Zone:	6' (1830 mm)
Weight:	90 lbs. Deck To Deck 93 lbs. Deck To Ground
Concrete:	3.7 Cu. Ft. Deck To Ground
Fall Height:	Deck Height Plus 1"

Installation Instructions

DECK MOUNT

- 1) Fasten tunnel sections together using 3/8" x 1 1/8" BHCS w/pin with roto tunnel contoured washers and attachment blocks with 3/8" standard hex nuts on standard tunnel end. Refer to the Tunnel Assembly Detail.
- 2) Attach foot strips to tunnel sections using 3/8" x 7/8" BHCS w/pin with 3/8" SAE flat washers and 3/8" flange nuts w/pin.
- 3) Attach crawl tunnel to panels using 3/8" x 7/8" BHCS w/pin with roto tunnel contoured washers and 3/8" flange nuts w/pin, as shown.
- 4) Attach offset hanger clamps to posts at height shown using 5" half clamps, 3/8" x 1 1/8" BHCS w/pin and 3/8" tee nuts. Refer to the Typical Offset Hanger Clamp Spec Sheet.
- 5) Attach tunnel assembly and panels to the face of the deck using 3/8" x 7/8" BHCS w/pin with 3/8" SAE flat washers and 3/8" flange nuts w/pin. Refer to the Tenderdeck Detail.
- 6) Attach panels to the offset hanger clamp assemblies using 3/8" x 3 3/4" BHCS w/pin, spacer tubes and 3/8" flange nuts w/pin, as shown.
- 7) Install protective surfacing before users are allowed to play on the structure.

GROUND LEVEL

- 1) Dig footings spaced as shown.
- 2) Fasten tunnel sections together using 3/8" x 1 1/8" BHCS w/pin with roto tunnel contoured washers and attachment blocks with 3/8" standard hex nuts on standard tunnel end. Refer to the Tunnel Assembly Detail.
- 3) Attach foot strips to tunnel sections using 3/8" x 7/8" BHCS w/pin with 3/8" SAE flat washers and 3/8" flange nuts w/pin.
- 4) Attach crawl tunnel to panels using 3/8" x 7/8" BHCS w/pin with roto tunnel contoured washers and 3/8" flange nuts w/pin, as shown.
- 5) Attach offset hanger clamp assemblies to posts at height shown, using half clamps and 3/8" x 1 1/8" BHCS w/pin and with 3/8" tee nuts. Refer To The Typical Offset Hanger Clamp Spec Sheet.
- 6) Attach angled panel bracket to bottom of 16"/24" offset tunnel panel using 3/8" x 5/8" BHCS w/pin and 3/8" flange nuts w/pin. See Ground Level.
- 7) Attach tunnel assembly panel to the face of the deck using 3/8" x 7/8" BHCS w/pin with 3/8" SAE flat washers and 3/8" flange nuts w/pin. Refer to the Tenderdeck Detail.
- 8) Attach angled panel bracket with panel to offset hanger clamp assemblies using 5/8" x 2 1/4" BHCS w/pin. See Ground Level.
- 9) Attach top of panels to offset hanger clamp assemblies using 3/8" x 3 3/4" BHCS w/pin, spacer tubes and 3/8" flange nuts w/pin. See Ground Level.
- 10) Install 1/4" x 5/8" drive rivets in all 5" half clamps. Refer to the Typical Offset Hanger Clamp Spec Sheet.
- 11) With posts plumb pour concrete footings. Allow concrete footings to cure a minimum of 72 hours before users are allowed to play on the structure.
- 12) Install protective surfacing before users are allowed to play on the structure.

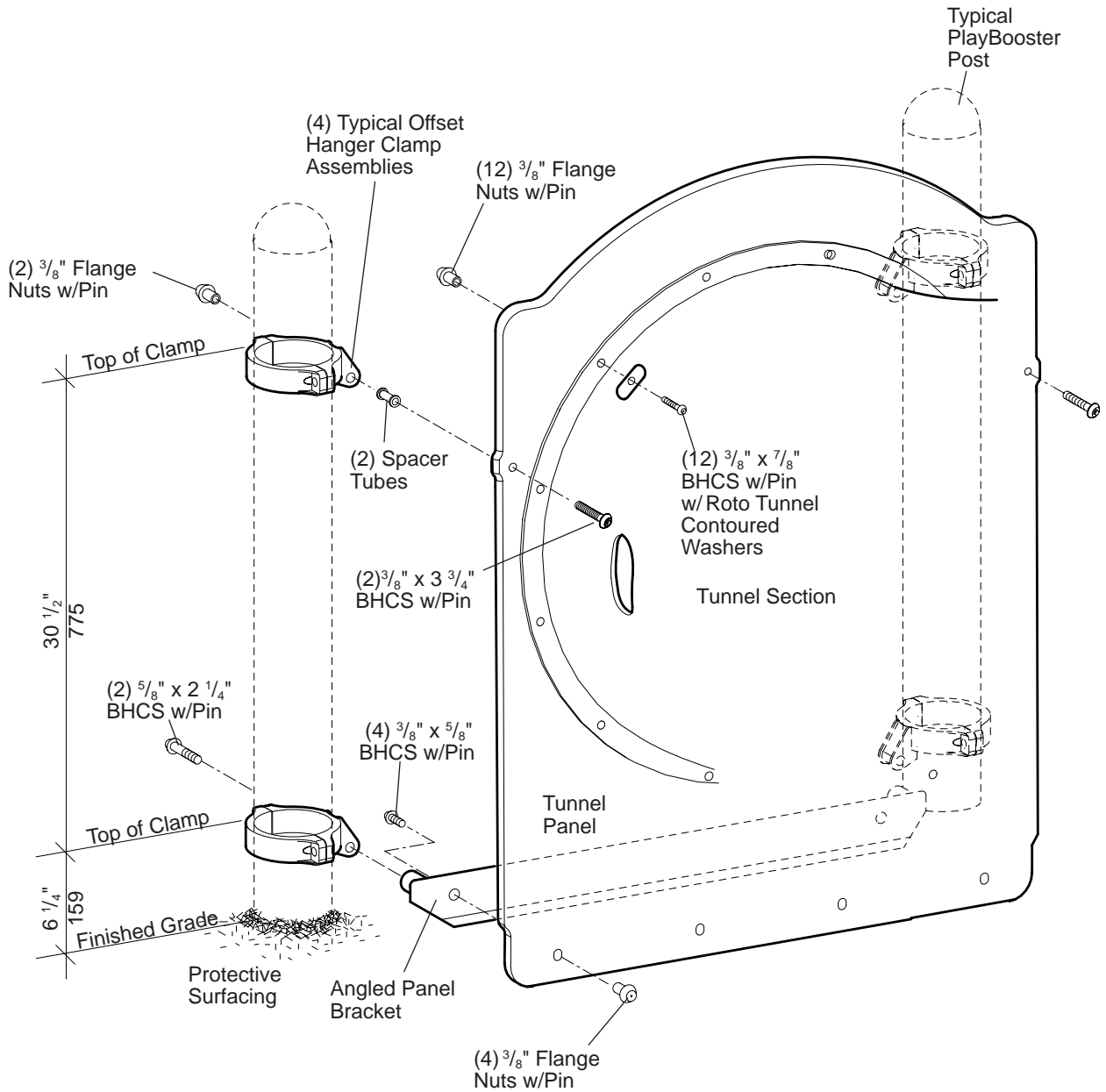

**GROUND
 LEVEL**

NOTE: Ground level maximum deck height is 24".

