

TOWN OF ARLINGTON

ARLINGTON RENOVATIONS TO EXISTING BUILDINGS

ARLINGTON, MASSACHUSETTS

CONSTRUCTION DOCUMENTS

DRAWING LIST

- A000 COVER SHEET
- D100 DEMOLITION PLANS AND ELEVATIONS
- A100 BATHHOUSE PLAN
- A101 BATHHOUSE ROOF PLAN AND RCP
- A102 FILTRATION BUILDING ROOF PLAN AND ELEVATIONS
- A103 FILTRATION BUILDING SECTIONS
- A102 BATHHOUSE ELEVATIONS
- A202 INTERIOR ELEVATIONS
- A301 SECTION
- A302 DETAILS
- A303 DOOR AND FINISH SCHEDULES
- PD100 BATHHOUSE PLUMBING DEMO PLAN
- P100 BATHHOUSE PLUMBING PLAN
- P200 BATHHOUSE PLUMBING SCHEDULES AND DETAILS
- P300 PLUMBING SPECIFICATIONS
- H100 BATHHOUSE HVAC PLAN
- E000 BATHHOUSE ELECTRICAL LEGEND DETAILS AND NOTES
- E100 BATHHOUSE ELECTRICAL PLAN DEMO AND NEW WORK
- E200 BATHHOUSE ELECTRICAL SPECIFICATIONS

PREPARED BY:

LANDSCAPE ARCHITECT:
 Kyle Zick Landscape Architecture, Inc.
 36 Bromfield Street, Suite 202
 Boston, MA 02108
 617-451-1018 Tel
 www.kylezick.com

ARCHITECT:
 Bargmann Hendrie + Archetype, Inc.
 9 Channel Center Street #300, Boston, MA 02210
 617-350-0450 Tel
 617-350-0215 Fax

CIVIL ENGINEER:
 Woodard & Curran, Inc.
 980 Washington Street #325, Dedham, MA 02026
 800-446-5518 Tel

ENVIRONMENTAL CONSULTING:
 SWCA Environmental Consultants
 15 Research Drive, Amherst, MA 01002
 413-575-9883
 Tel



LOCATION MAP
Lowell Street/Arlington Reservoir
Arlington, MA



ARLINGTON
 RENOVATIONS TO
 EXISTING
 BUILDINGS
 ARLINGTON, MASSACHUSETTS

TOWN OF ARLINGTON

NO.	REVISION	DATE

kzla
 Kyle Zick Landscape Architecture, Inc.
 36 Bromfield Street Suite 202
 Boston, MA 02108
 617 451-1018 Tel
 www.kylezick.com

ARCHITECT
bh+a
 Bargmann Hendrie + Archetype, Inc.
 9 Channel Center Street
 Boston, MA 02210
 617 350-0450 Tel

CONSTRUCTION DOCUMENTS

Job Number:
 Project: ARLINGTON RES.
 Drawn By: BH + A Checked By: KZ
 Date: NOVEMBER 10, 2020
 Scale: N/A
 Drawing Title:

COVER SHEET

A000

**ARLINGTON
RENOVATIONS TO
EXISTING
BUILDINGS**
ARLINGTON, MASSACHUSETTS

TOWN OF ARLINGTON

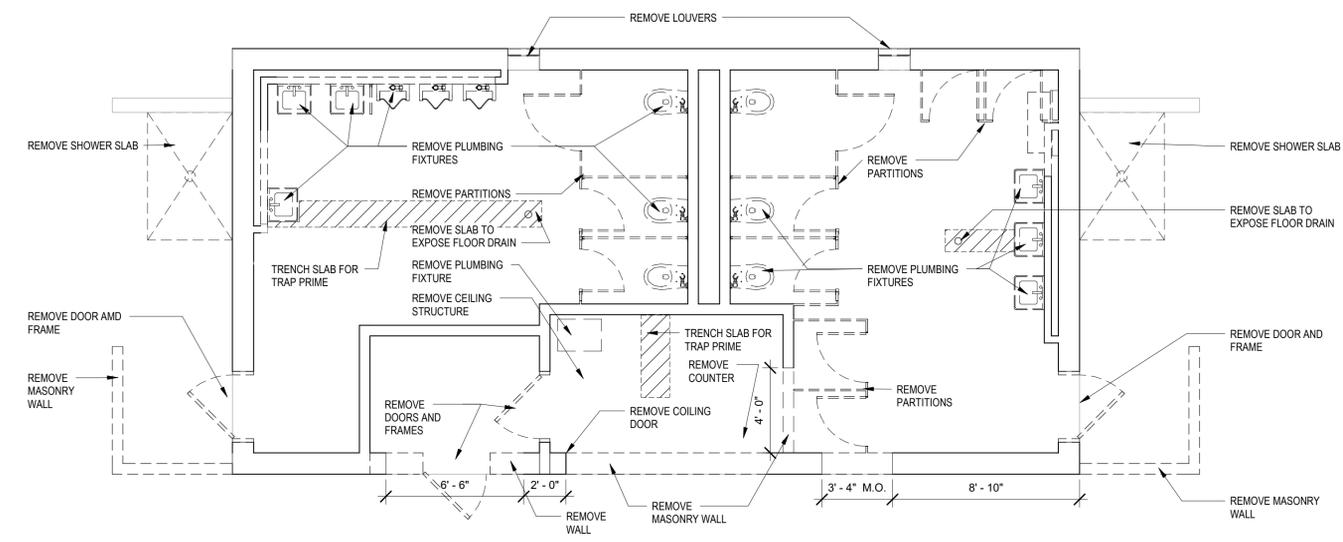

1 EXISTING FLOOR PLAN
1/4" = 1'-0"

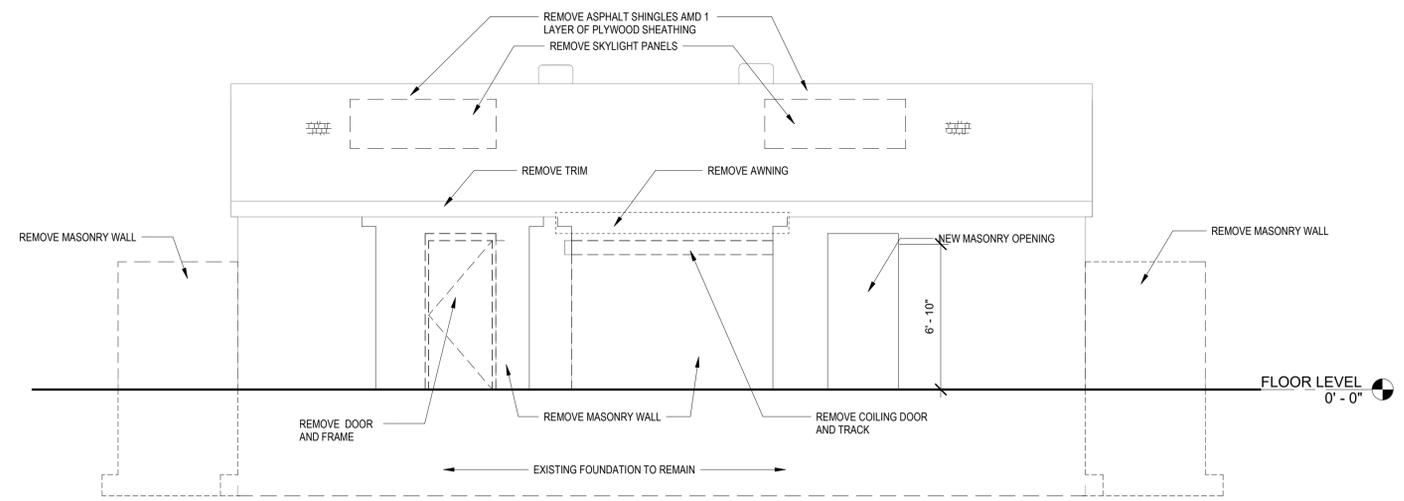

2 DEMOLITION WEST ELEVATION
1/4" = 1'-0"

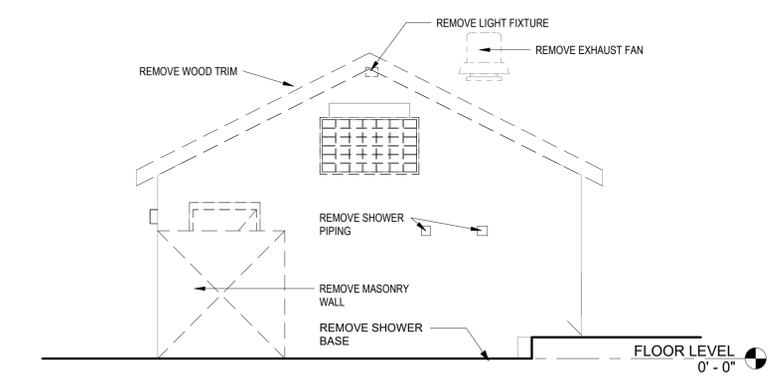

3 EXISTING NORTH ELEVATION
1/4" = 1'-0"

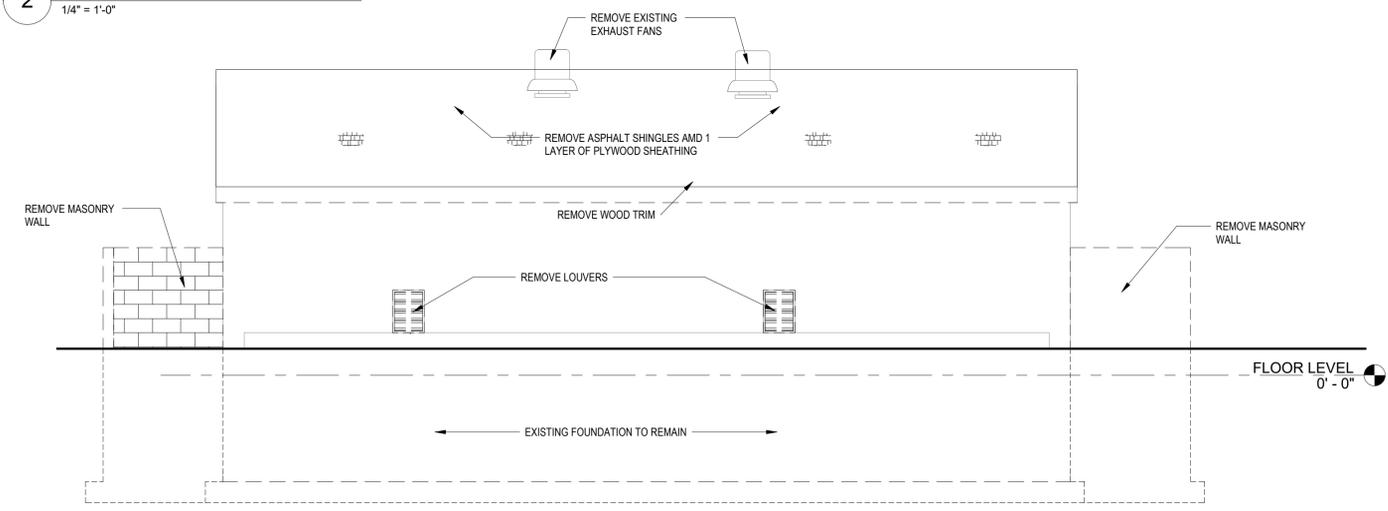

4 DEMOLITION EAST ELEVATION
1/4" = 1'-0"

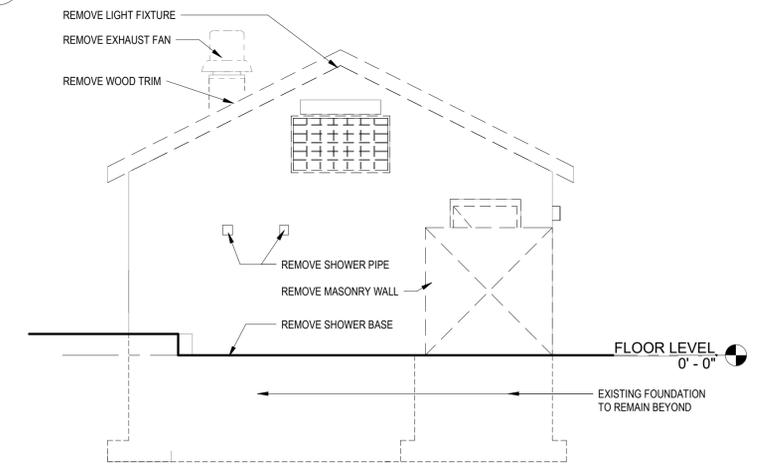

5 DEMOLITION SOUTH ELEVATION
1/4" = 1'-0"

NO.	REVISION	DATE

kzla
Kyle Zick Landscape Architecture, Inc.
36 Bromfield Street Suite 202
Boston, MA 02108
617 451-1018 Tel
www.kyezick.com

ARCHITECT
bh+a
Bargmann Hendrie + Archetype, Inc.
9 Channel Center Street
Boston, MA 02210
617 350-0450 Tel

CONSTRUCTION DOCUMENTS

Job Number:
Project: ARLINGTON RES.
Drawn By: BH + A Checked By: KZ
Date: NOVEMBER 10, 2020
Scale: 1/4" = 1'-0"
Drawing Title:

Demolition plans and Elevations

D100

2 ROOF FRAMING PLAN
 1/4" = 1'-0"

3 DORMER FRAMING PLAN
 1/4" = 1'-0"

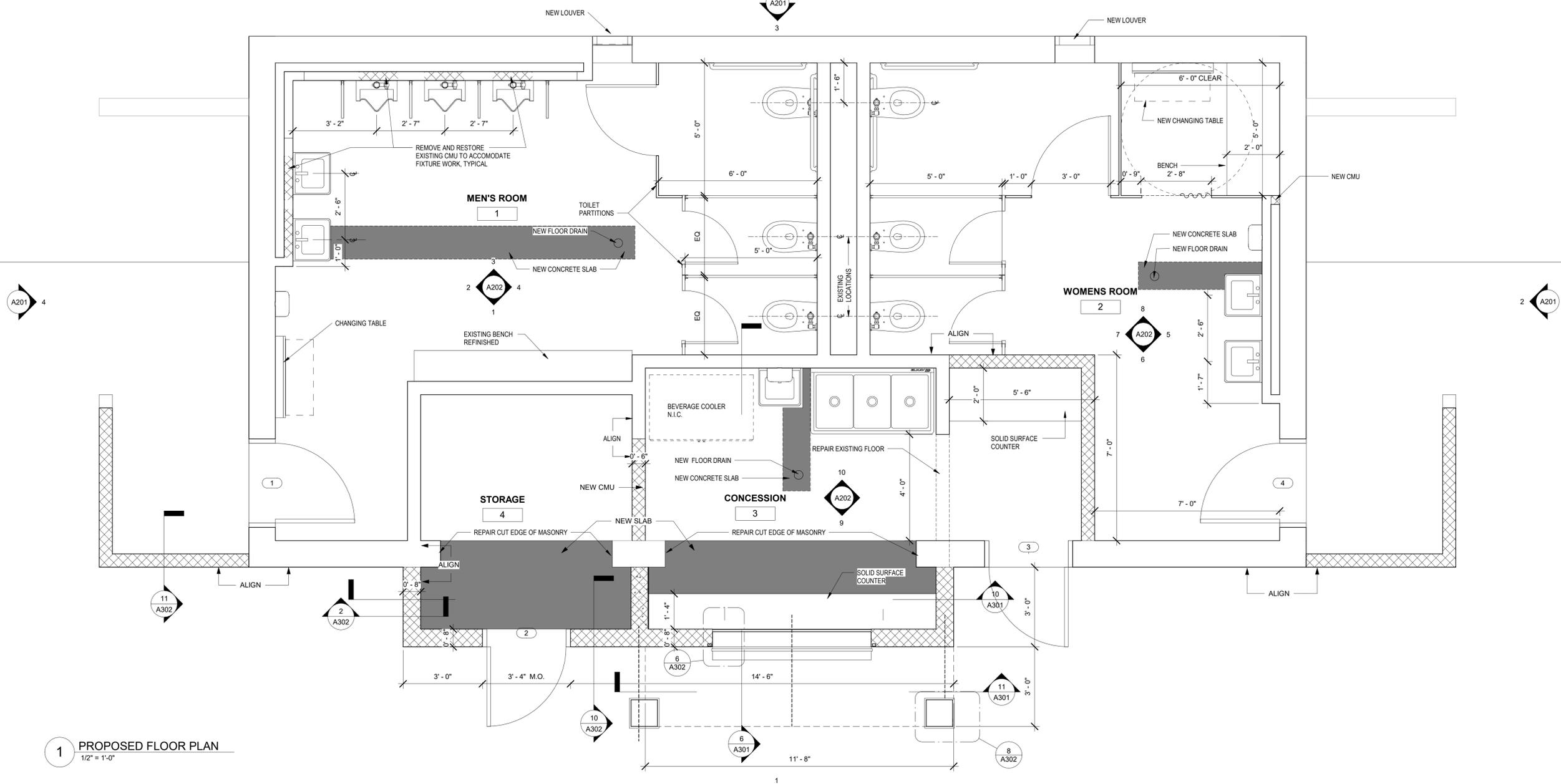
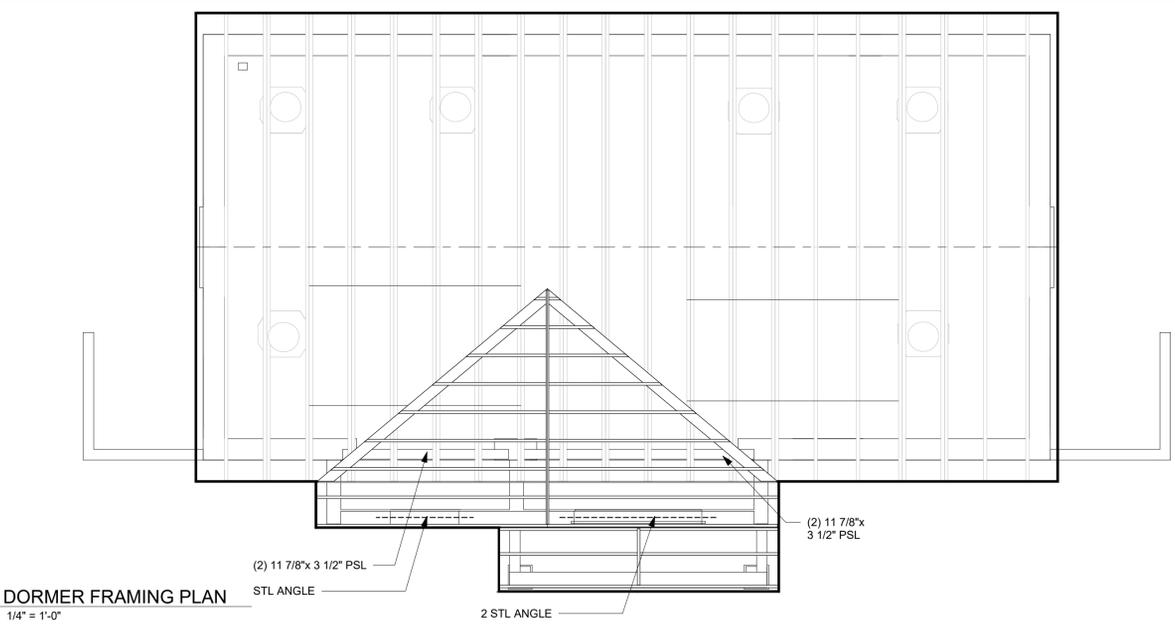
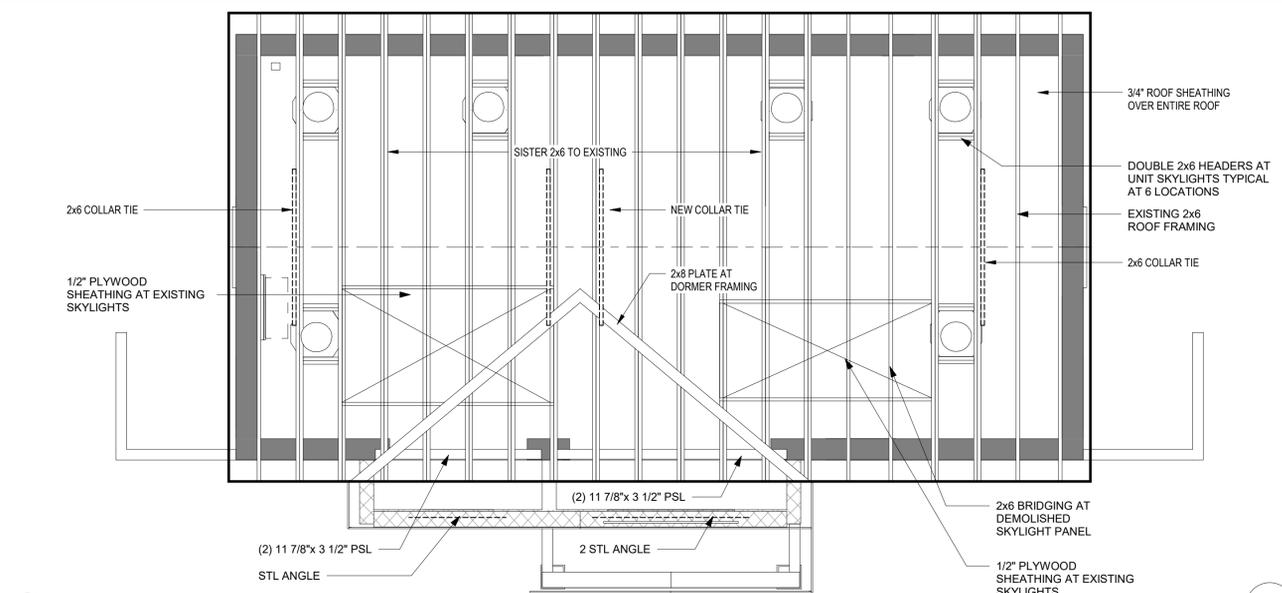

1 PROPOSED FLOOR PLAN
 1/2" = 1'-0"

NO.	REVISION	DATE

kzla
 Kyle Zick Landscape Architecture, Inc.
 36 Bromfield Street Suite 202
 Boston, MA 02108
 617 451-1018 Tel
 www.kyzezick.com

bh+a
 Bargmann Hendrie + Archetype, Inc.
 9 Channel Center Street
 Boston, MA 02210
 617 350-0450 Tel

CONSTRUCTION DOCUMENTS

Job Number:
 Project: ARLINGTON RES.
 Drawn By: BH + A Checked By: KZ
 Date: NOVEMBER 10, 2020
 Scale: As indicated
 Drawing Title:

Bathhouse Plan

A100

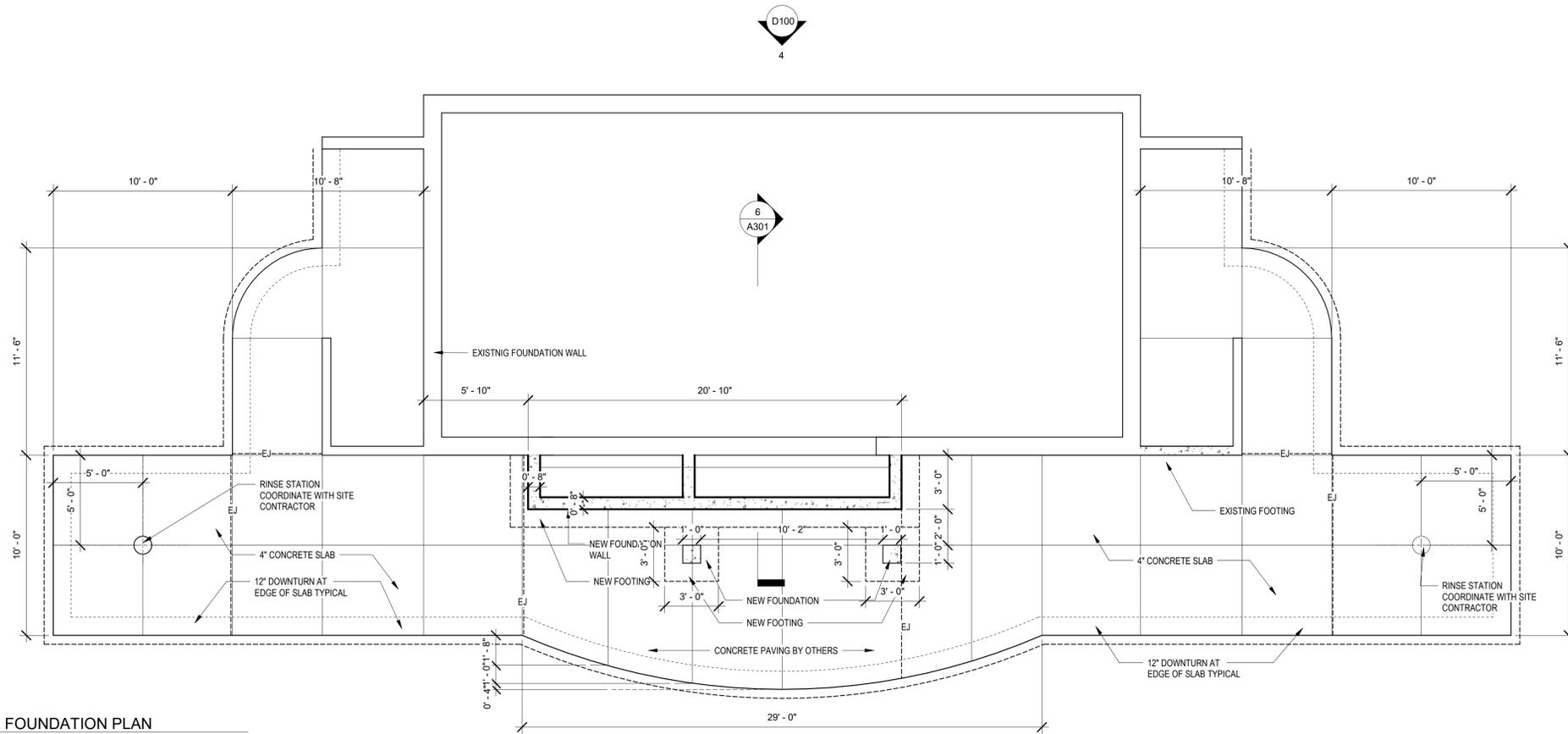

1 FOUNDATION PLAN
1/4" = 1'-0"

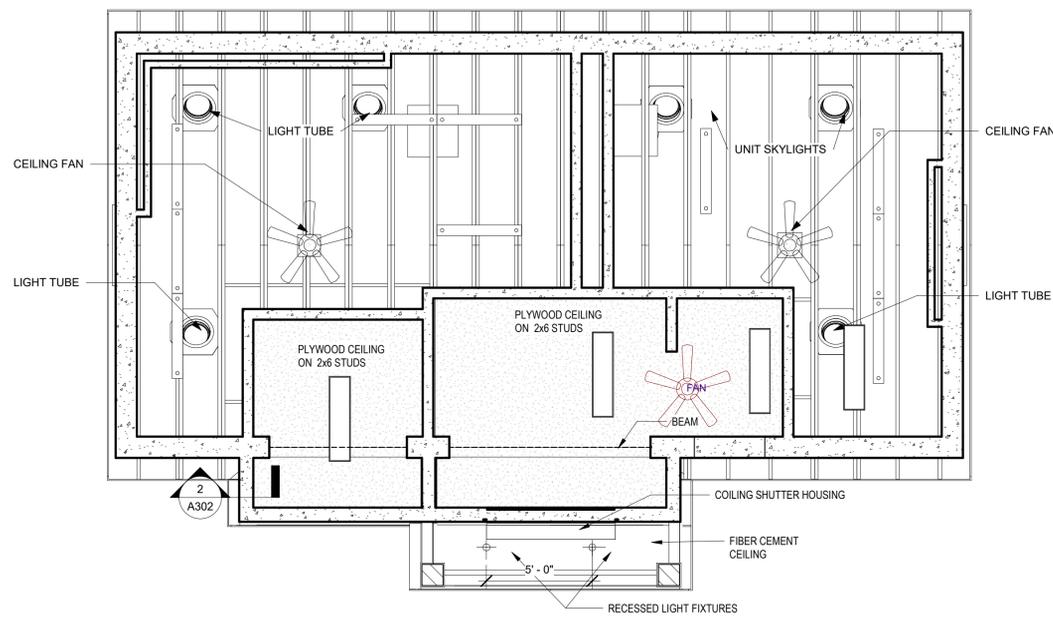

2 RCP - FLOOR LEVEL
1/4" = 1'-0"

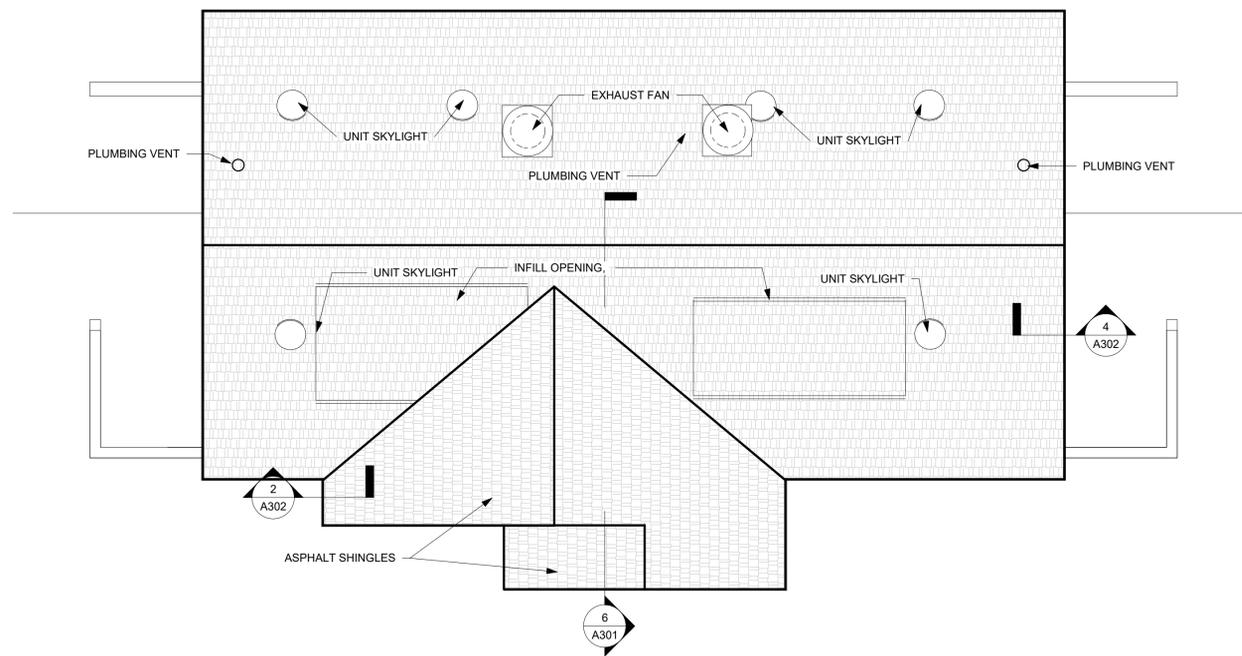

3 ROOF PLAN
1/4" = 1'-0"

NO.	REVISION	DATE

kzla
Kyle Zick Landscape Architecture, Inc.
36 Bromfield Street Suite 202
Boston, MA 02108
617 451-1018 Tel
www.kylezick.com

ARCHITECT
bh+a
Bargmann Hendrie + Archetype, Inc.
9 Channel Center Street
Boston, MA 02210
617 350-0450 Tel

CONSTRUCTION DOCUMENTS

Job Number:
Project: ARLINGTON RES.
Drawn By: BH + A Checked By: KZ
Date: NOVEMBER 10, 2020
Scale: 1/4" = 1'-0"
Drawing Title:

Bathroom Roof Plan and
RCP

A101

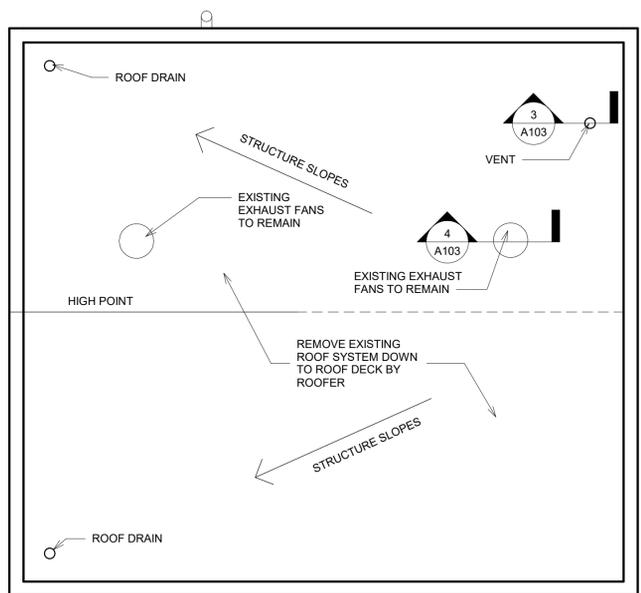

1 ROOF DEMOLITION PLAN
1/4" = 1'-0"

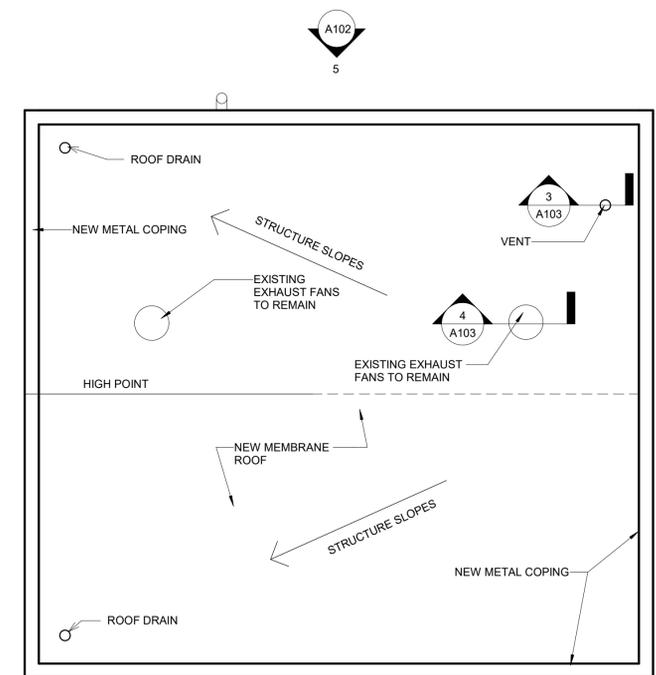

2 ROOF PLAN
1/4" = 1'-0"

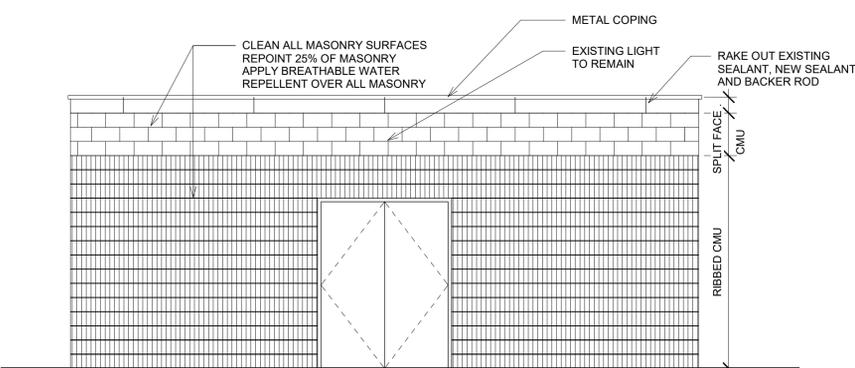

3 EXISTING EAST ELEVATION
1/4" = 1'-0"

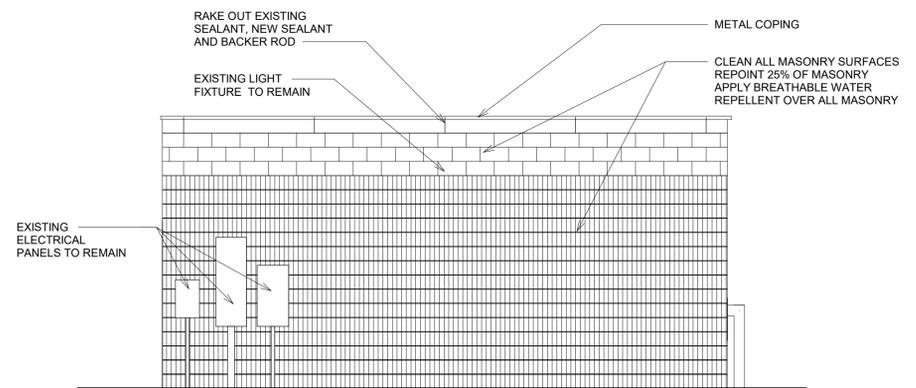

4 EXISTING NORTH ELEVATION
1/4" = 1'-0"

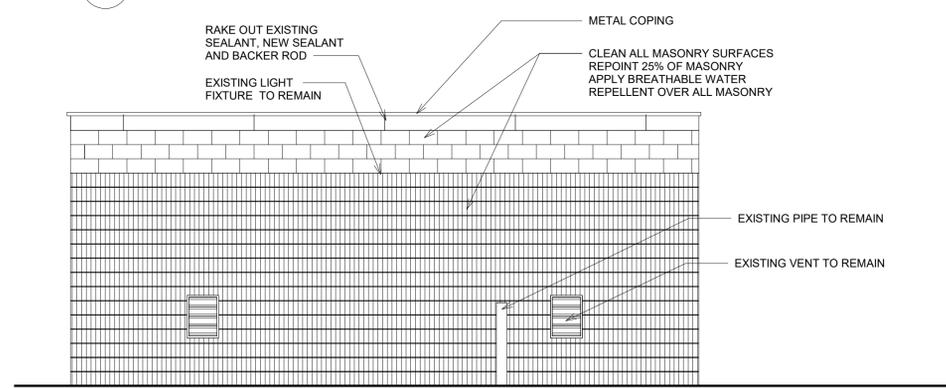

5 EXISTING WEST ELEVATION
1/4" = 1'-0"

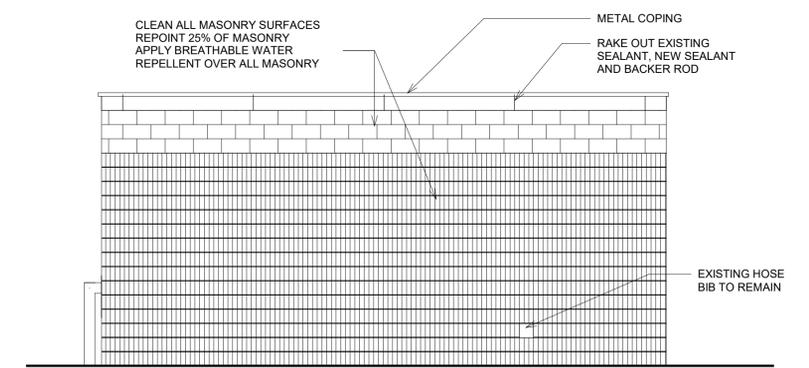

6 EXISTING SOUTH ELEVATION
1/4" = 1'-0"

NO.	REVISION	DATE

kzla
Kyle Zick Landscape Architecture, Inc.
36 Bromfield Street Suite 202
Boston, MA 02108
617 451-1018 Tel
www.kyzezick.com

ARCHITECT
bh+a
Bargmann Hendrie + Archetype, Inc.
9 Channel Center Street
Boston, MA 02210
617 350-0450 Tel

CONSTRUCTION DOCUMENTS

Job Number:
Project: ARLINGTON RES.
Drawn By: BH + A Checked By: KZ
Date: NOVEMBER 10, 2020
Scale: 1/4" = 1'-0"
Drawing Title:

Filtration Building Roof Plan
and Elevations

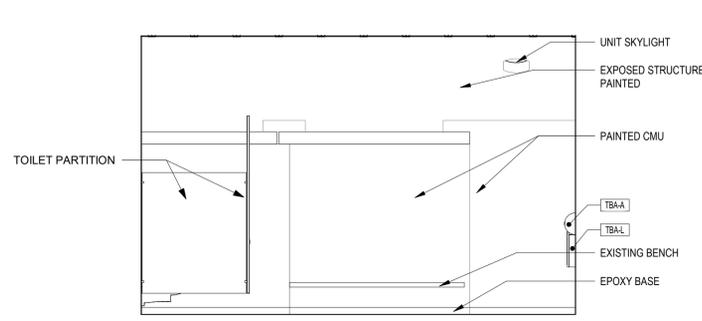

1 MEN'S ROOM 1
 1/4" = 1'-0"

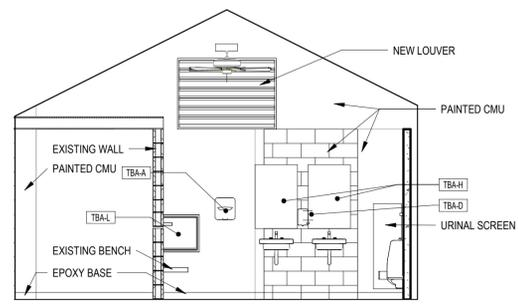

2 MEN'S ROOM 2
 1/4" = 1'-0"

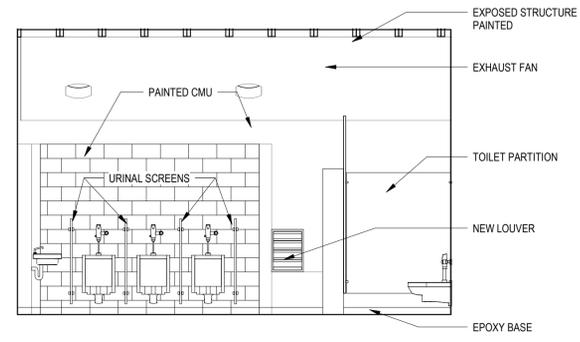

3 MEN'S ROOM 3
 1/4" = 1'-0"

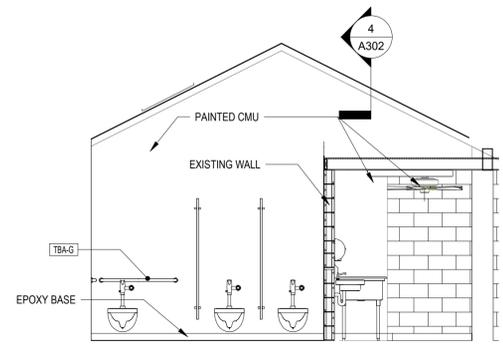

4 MEN'S ROOM 4
 1/4" = 1'-0"

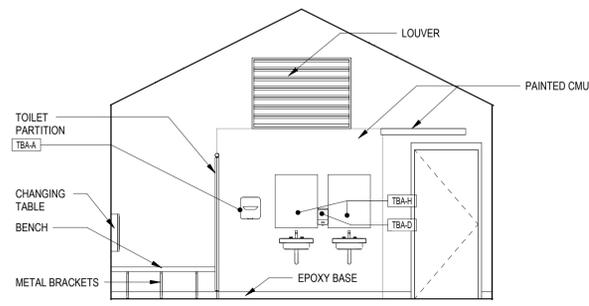

5 WOMEN'S ROOM 1
 1/4" = 1'-0"

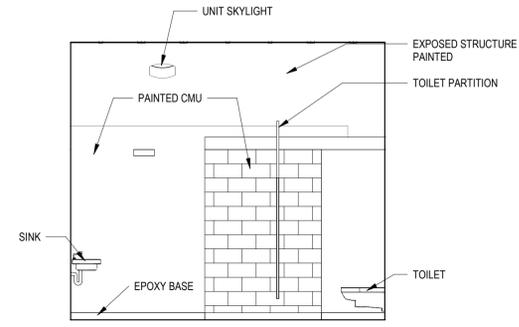

6 WOMEN'S ROOM 2
 1/4" = 1'-0"

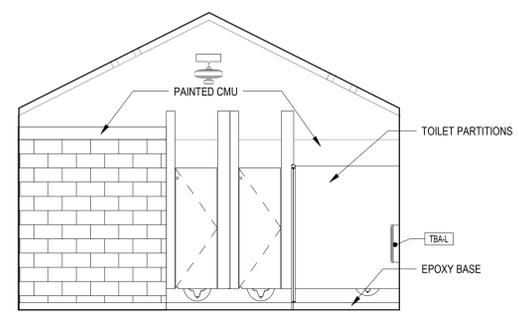

7 WOMEN'S ROOM 3
 1/4" = 1'-0"

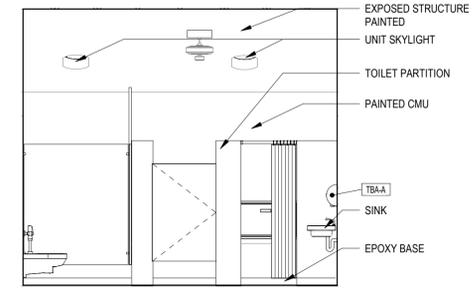

8 WOMEN'S ROOM 4
 1/4" = 1'-0"

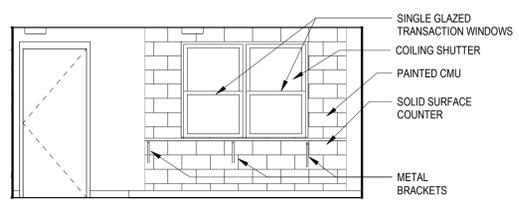

9 CONSESSION 1
 1/4" = 1'-0"

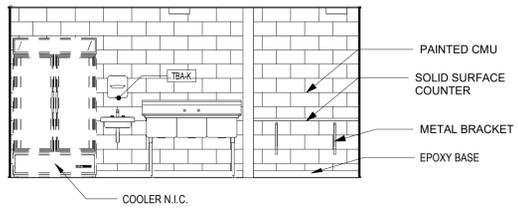

10 CONSESSION 2
 1/4" = 1'-0"

- TBA-A ELECTRIC HAND DRYER
- TBA-C WASTE DISPOSAL (WOMEN'S ONLY)
- TBA-D SOAP DISPENSER
- TBA-E TISSUE DISPENSER
- TBA-G GRAB BARS AT HC WATER CLOSET
- TBA-H MIRROR
- TBA-J WASTE RECEPTACLE
- TBA-K PAPER TOWEL DISPENSER
- TBA-L DIAPER CHANGING
- TBA-M COAT HOOK

TOILET AND BATHROOM ACCESSORIES MOUNTING HEIGHT

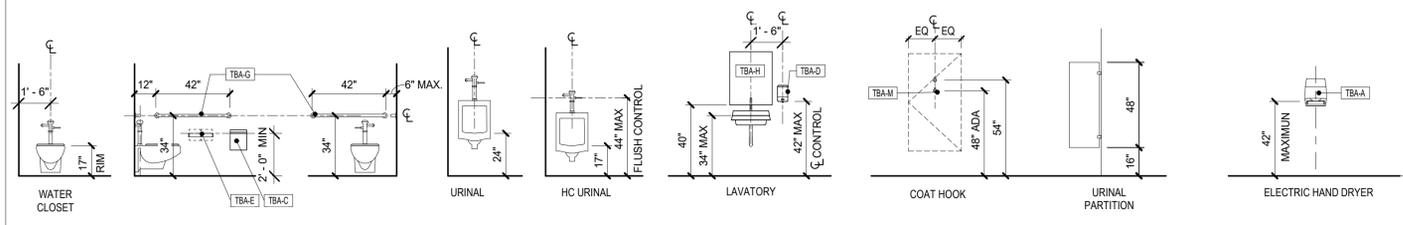

NO.	REVISION	DATE

kzla
 Kyle Zick Landscape Architecture, Inc.
 36 Bromfield Street Suite 202
 Boston, MA 02108
 617 451-1018 Tel
 www.kyzezick.com

Architect
bh+a
 Bargmann Hendrie + Archetype, Inc.
 9 Channel Center Street
 Boston, MA 02210
 617 350-0450 Tel

CONSTRUCTION DOCUMENTS

Job Number:
 Project: ARLINGTON RES.
 Drawn By: BH + A Checked By: KZ
 Date: NOVEMBER 10, 2020
 Scale: 1/4" = 1'-0"
 Drawing Title:

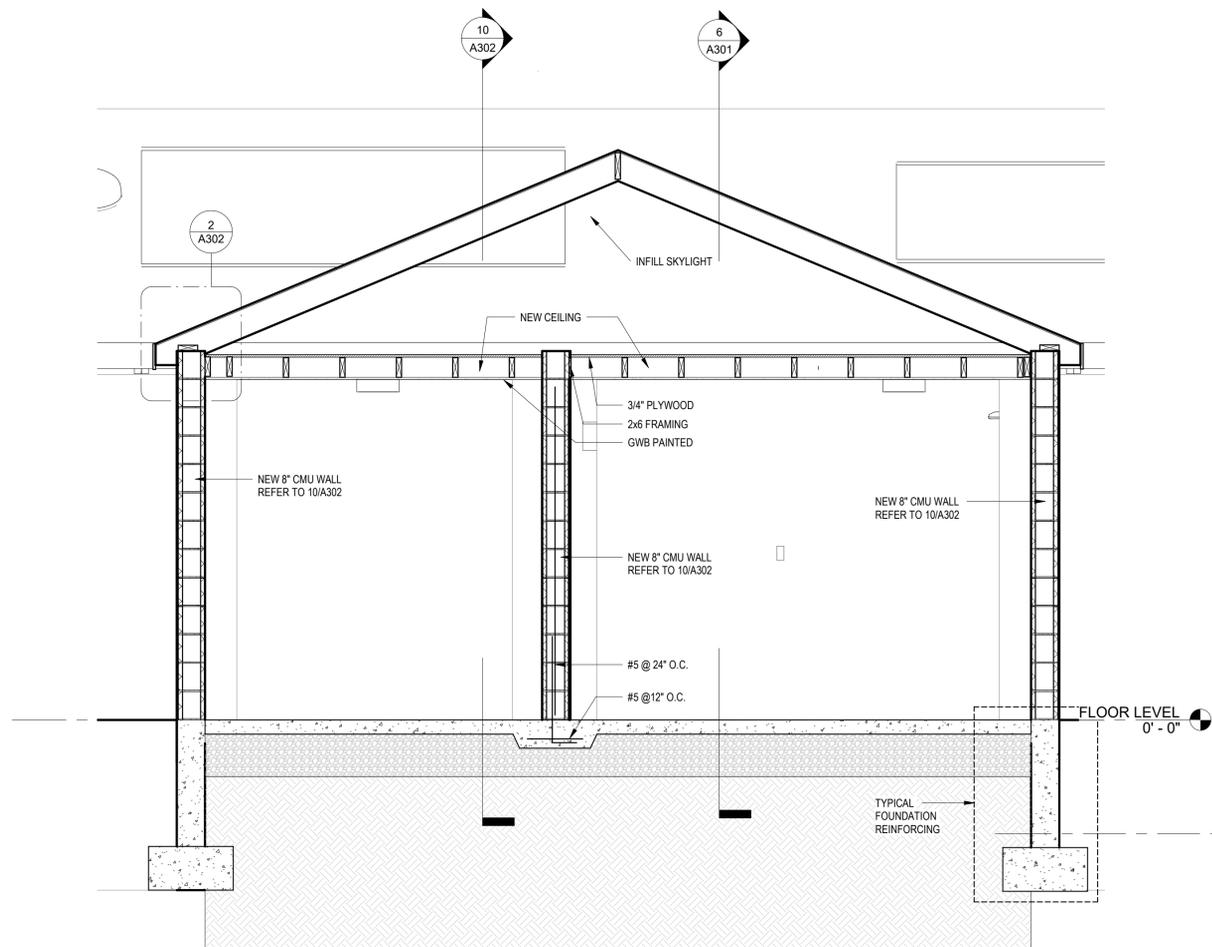

10 ADDITION SECTION
 1/2" = 1'-0"

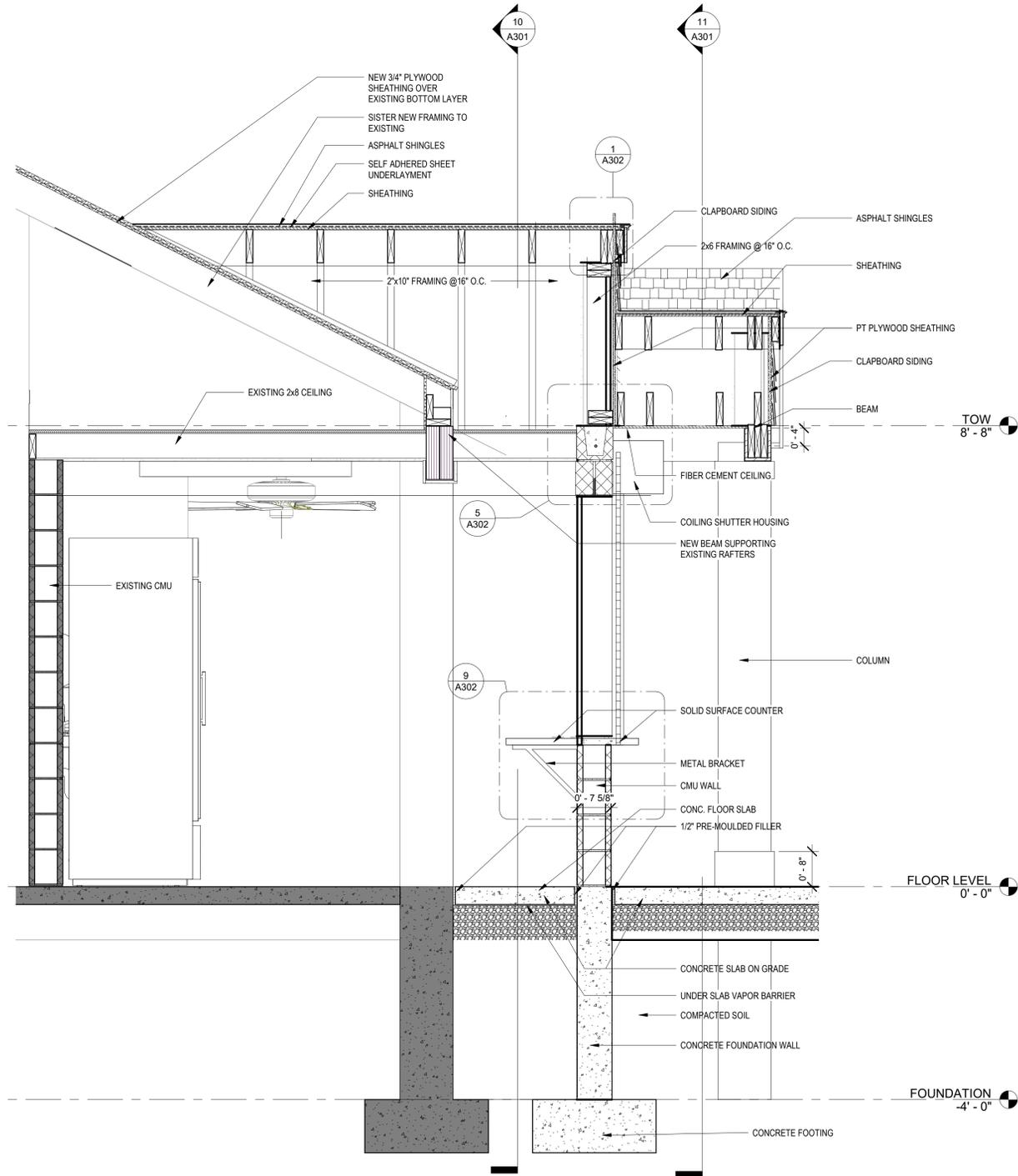

6 Dormer Section
 3/4" = 1'-0"

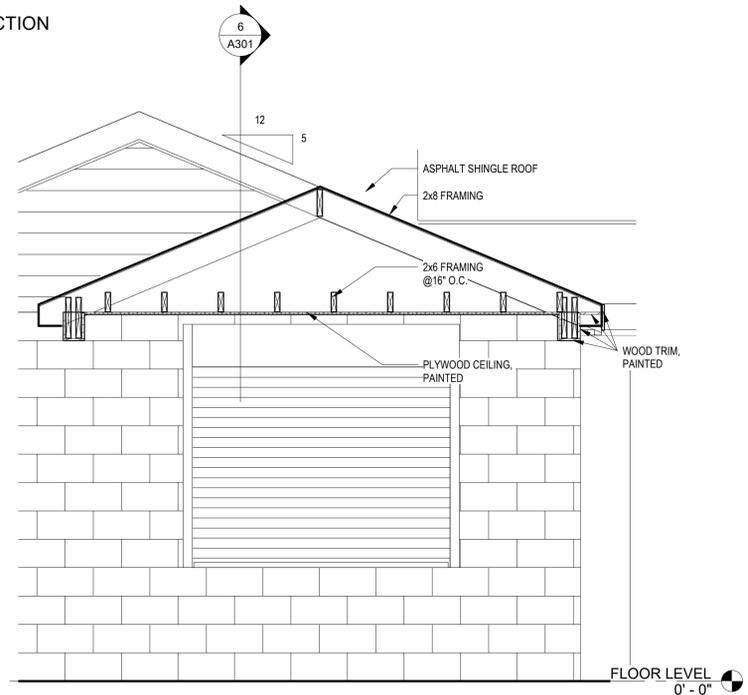

11 FRONT SECTION
 1/2" = 1'-0"

NO.	REVISION	DATE

kzla
 Kyle Zick Landscape Architecture, Inc.
 36 Bromfield Street Suite 202
 Boston, MA 02108
 617 451-1018 Tel
 www.kyzezick.com

bh+a
 Bargmann Hendrie + Archetype, Inc.
 9 Channel Center Street
 Boston, MA 02210
 617 350-0450 Tel

CONSTRUCTION DOCUMENTS

Job Number:
 Project: ARLINGTON RES.
 Drawn By: BH + A Checked By: KZ
 Date: NOVEMBER 10, 2020
 Scale: As indicated
 Drawing Title:

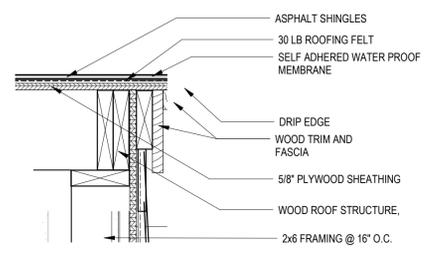

1 RAKE DETAIL
 1 1/2" = 1'-0"

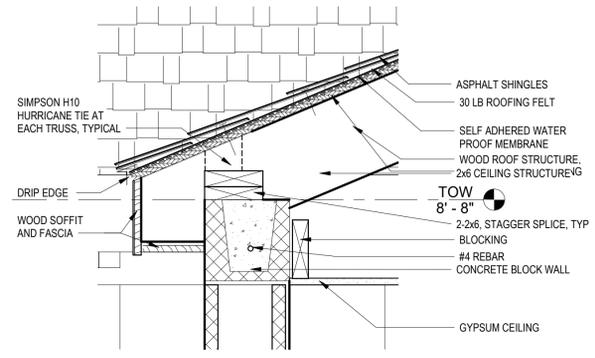

2 ADDITION EAVE DETAIL
 1 1/2" = 1'-0"

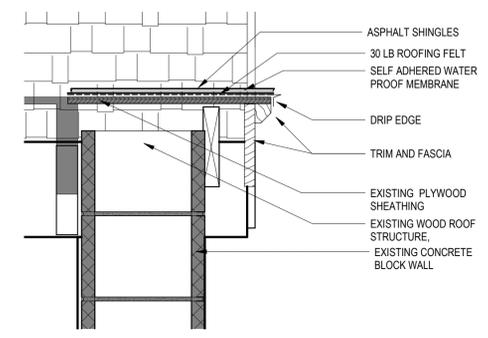

4 RAKE DETAIL AT EXISTING WALL
 1 1/2" = 1'-0"

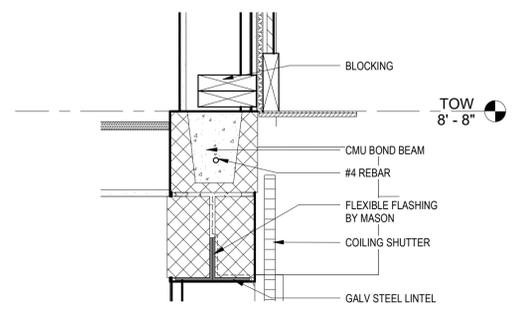

5 WINDOW HEAD
 1 1/2" = 1'-0"

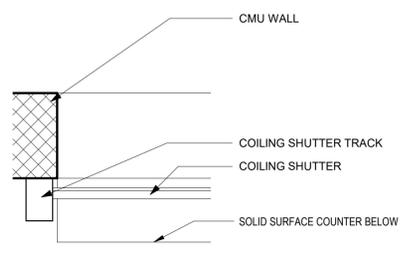

6 WINDOW JAMB
 1 1/2" = 1'-0"

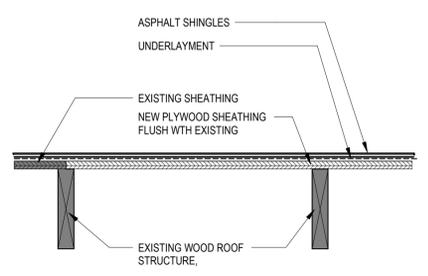

7 SKYLIGHT INFILL
 1 1/2" = 1'-0"

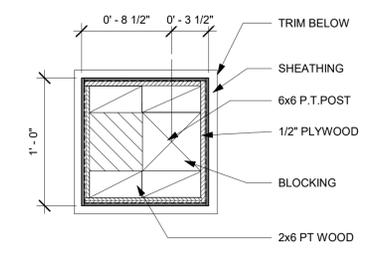

8 COLUMN DETAIL
 1 1/2" = 1'-0"

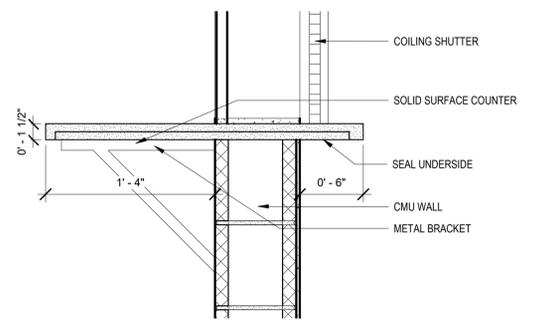

9 WINDOW SILL
 1 1/2" = 1'-0"

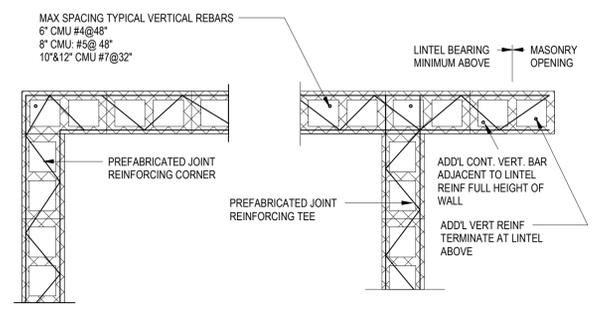

3 CMU REINFORCING
 3/4" = 1'-0"

NOTE:
 EXCEPT WHERE OTHERWISE NOTED AT ALL INTERSECTING WALLS AND CORNERS, PROVIDE PRE-FABRICATED CORNERS AND TEES IN ALTERNATE HORIZONTAL COURSES. LAP WITH TYPICAL JOINT REINFORCING
 PROVIDE ADDITIONAL REBARS AT CORNERS, TEES, ENDS OF WALLS AND EACH SIDE OF CONTROL JOINTS

LINTELS SHALL BE PROVIDED OVER ALL OPENINGS IN MASONRY WALLS ACCORDING TO THE FOLLOWING SCHEDULE UNLESS OTHERWISE NOTED AND ARE TO BE HOT DIPPED GALVANIZED. PROVIDE 8" BEARING AT EACH END OF LINTEL AND ONE "L" FOR EACH 4" OF WALL THICKNESS.

OPENINGS UP TO 3'-0"	L3 1/2"x3 1/2"x 5/16"	3 1/2" LEG VERTICAL
3'-0" TO 4'-6"	L4 1/2"x3 1/2"x 5/16"	4 1/2" LEG VERTICAL
4'-7" TO 6'-0"	L5 1/2"x3 1/2"x 5/16"	5 1/2" LEG VERTICAL
6'-1" TO 8'-0"	L5 1/2"x3 1/2"x 5/16"	6 1/2" LEG VERTICAL

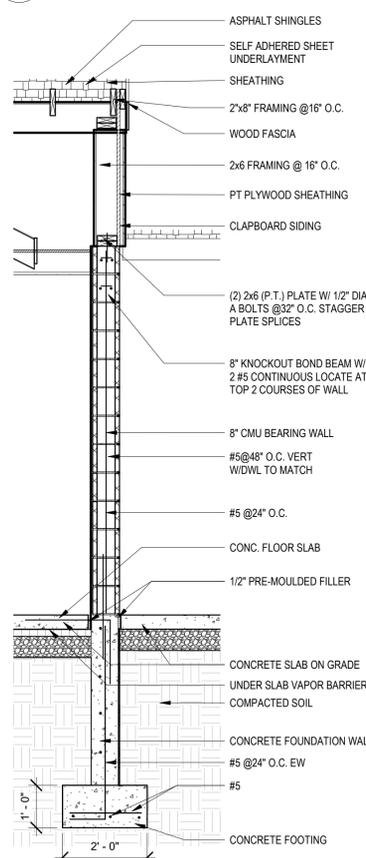

10 NEW WALL
 1/2" = 1'-0"

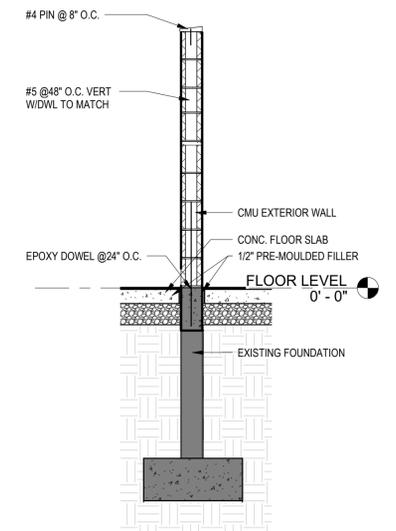

11 NEW SCREEN WALL
 1/2" = 1'-0"

NO.	REVISION	DATE

kzla
 Kyle Zick Landscape Architecture, Inc.
 36 Bromfield Street Suite 202
 Boston, MA 02108
 617 451-1018 Tel
 www.kyezick.com

ARCHITECT
bh+a
 Bargmann Hendrie + Archetype, Inc.
 9 Channel Center Street
 Boston, MA 02210
 617 350-0450 Tel

CONSTRUCTION DOCUMENTS

Job Number:
 Project: ARLINGTON RES.
 Drawn By: BH + A Checked By: KZ
 Date: NOVEMBER 10, 2020
 Scale: As indicated
 Drawing Title:

Room Schedule						
Number	Name	Wall Finish	Ceiling Finish	Floor Finish	Base Finish	Comments
1	MEN'S ROOM	PAINTED CMU	PAINTED STRUCTURE	SEAMLESS QUARTZ	SEAMLESS QUARTZ	
2	WOMENS ROOM	PAINTED CMU	PAINTED STRUCTURE	SEAMLESS QUARTZ	SEAMLESS QUARTZ	
3	CONCESSION	PAINTED CMU	PAINTED STRUCTURE	SEAMLESS QUARTZ	SEAMLESS QUARTZ	
4	STORAGE	PAINTED CMU	PAINTED STRUCTURE	SEAMLESS QUARTZ	SEAMLESS QUARTZ	

Door Schedule													
Mark	Width	Height	Door type	Thickness	Door Material	Finish	Frame	Frame Material	Head Detail	Jamb Detail	Sill Detail	Hardware Set	Comments
1	3' - 0"	7' - 0"	A	0' - 1 3/4"	FIBERGLASS		1	FIBERGLASS	2/A303	3/A303	4/A303	3	
2	3' - 0"	7' - 0"	A	0' - 1 3/4"	FIBERGLASS		1	FIBERGLASS	2/A303	3/A303	4/A303	1	
3	3' - 0"	7' - 0"	B	0' - 1 3/4"	FIBERGLASS		1	FIBERGLASS	2/A303	3/A303	4/A303	2	
4	3' - 0"	7' - 0"	A	0' - 1 3/4"	FIBERGLASS		2	FIBERGLASS	2/A303	3/A303	4/A303	3	

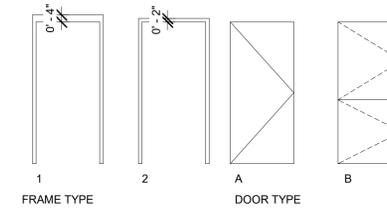

1 Door and Frame Types
1/4" = 1'-0"

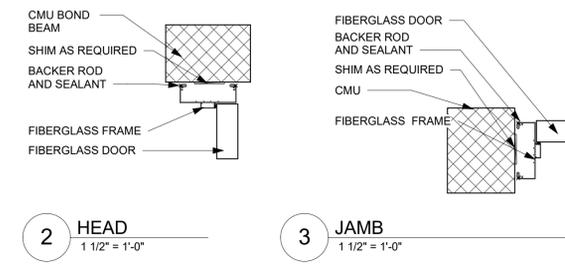

ARLINGTON RENOVATIONS TO EXISTING BUILDINGS
ARLINGTON, MASSACHUSETTS
TOWN OF ARLINGTON

NO.	REVISION	DATE

kzla
Kyle Zick Landscape Architecture, Inc.
36 Bromfield Street Suite 202 Boston, MA 02108 617 451-1018 Tel www.kyzezick.com

ARCHITECT
bh+a
Bargmann Hendrie + Archetype, Inc.
9 Channel Center Street Boston, MA 02210 617 350-0450 Tel

CONSTRUCTION DOCUMENTS

Job Number:
Project: ARLINGTON RES.
Drawn By: BH + A Checked By: KZ
Date: NOVEMBER 10, 2020
Scale: As indicated
Drawing Title:

Door and Finish Schedules

A303

ARLINGTON
 RENOVATIONS TO
 EXISTING
 BUILDINGS
 ARLINGTON, MASSACHUSETTS

TOWN OF ARLINGTON

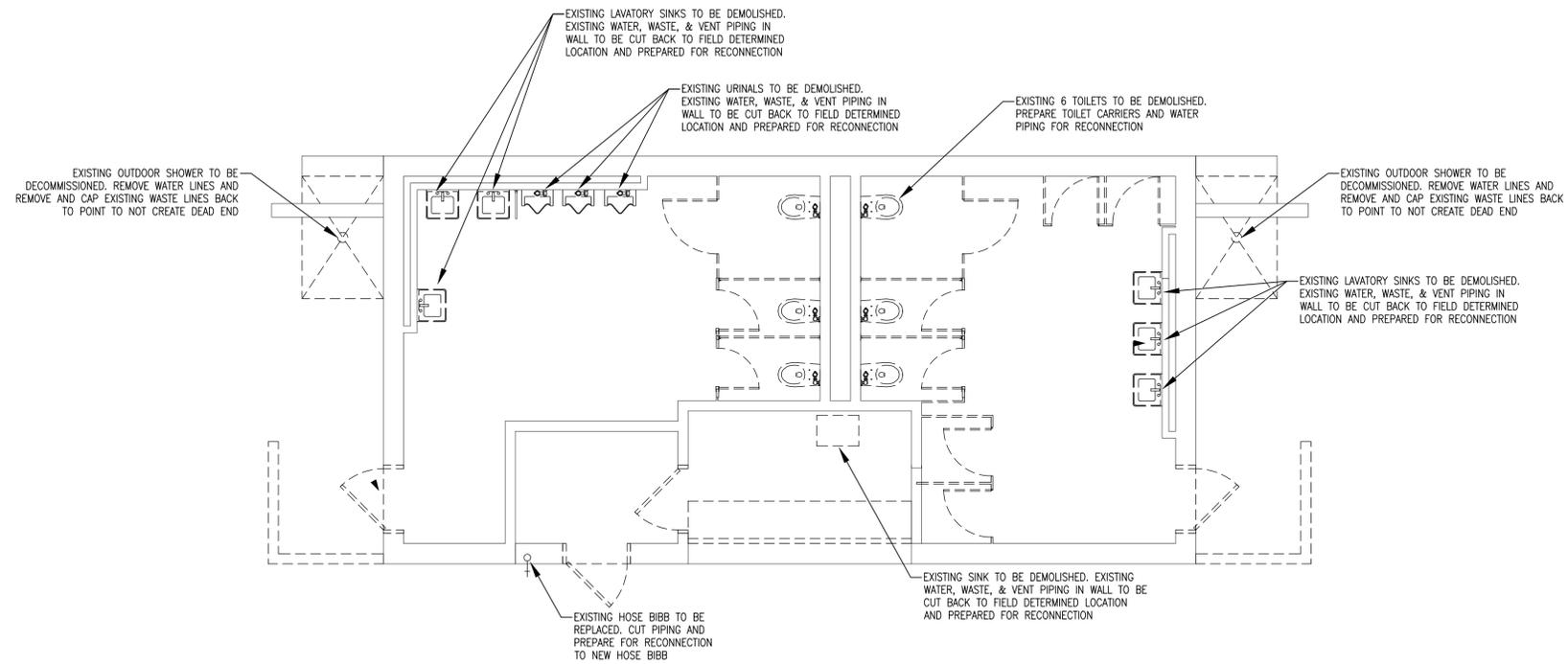

NO.	REVISION	DATE

kzla
 Kyle Zick Landscape Architecture, Inc.
 36 Bronfield Street Suite 202 Boston, MA 02108 617 451-1018 Tel www.kyzezick.com

bh+a
 Bargmann Hendrie + Archetype, Inc.
 9 Channel Center Street Boston, MA 02210 617 350-0450 Tel

CONSTRUCTION DOCUMENTS

Job Number:
 Project: ARLINGTON RES.
 Drawn By: KS Checked By: PP
 Date: NOVEMBER 10, 2020
 Scale:
 Drawing Title:

Bathhouse Plumbing
 Sheet Name
 Demo Plan

PD100

ARLINGTON
 RENOVATIONS TO
 EXISTING
 BUILDINGS
 ARLINGTON, MASSACHUSETTS

TOWN OF ARLINGTON

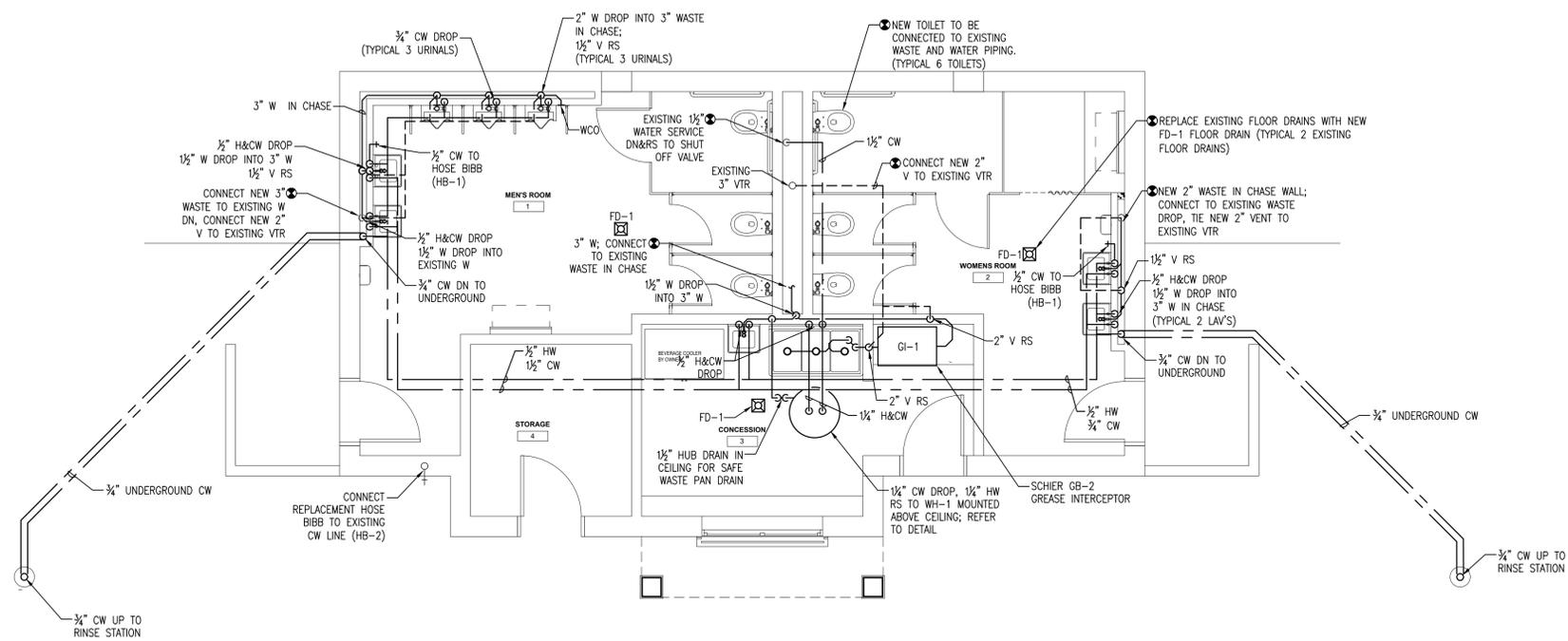

NO.	REVISION	DATE

kzla
 Kyle Zick Landscape Architecture, Inc.
 36 Bromfield Street Suite 202 Boston, MA 02108 617 451-1018 Tel www.kyzick.com

ARCHITECT
bh+a
 Bargmann Hendrie + Archetype, Inc.
 9 Channel Center Street Boston, MA 02210 617 350-0450 Tel

CONSTRUCTION DOCUMENTS

Job Number:
 Project: ARLINGTON RES.
 Drawn By: KS Checked By: PP
 Date: NOVEMBER 10, 2020
 Scale:
 Drawing Title:

Bathhouse
 Sheet Name
 Plumbing Plan

P100

1 PROPOSED FLOOR PLAN
 1/4" = 1'-0"

NOTE:
ALL FLOOR DRAINS TO BE INSTALLED WITH TRAP PRIMER SIMILAR TO "J.R. SMITH" PRIME-EZE WATER SAVER TRAP PRIMER FIG. # 2698 OR EQUAL (AS SHOWN ON DETAIL) WHERE A LAVATORY SINK IS IN CLOSE PROXIMITY. USE MECHANICAL TRAP PRIMER SIMILAR TO "PPP" MODEL P2-500 OR EQUAL WITH SERVICE VALVE AT FLOOR DRAIN LOCATIONS WHERE A LAVATORY SINK IS NOT IN CLOSE PROXIMITY

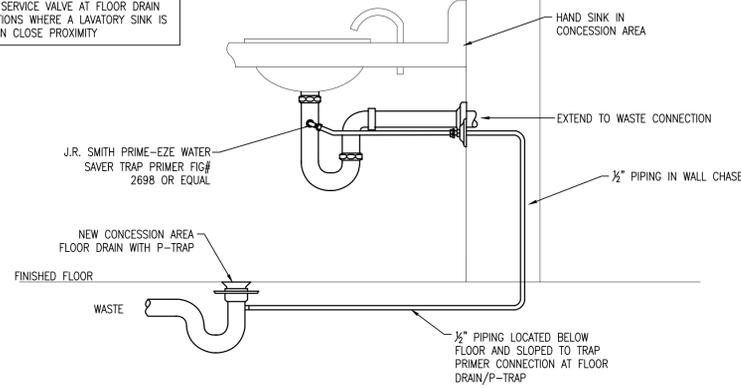

WATER SAVER TRAP PRIMER

N.T.S.

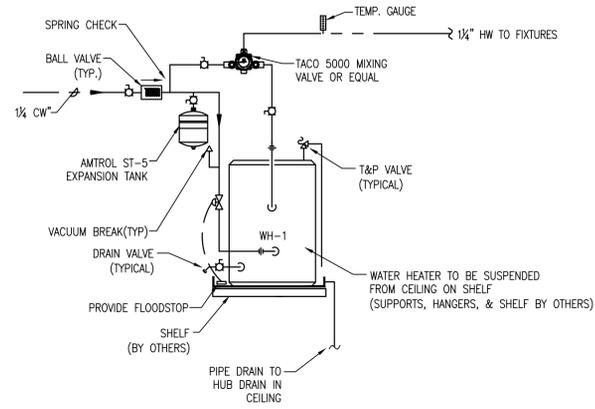

WALL MOUNTED ELECTRIC WATER HEATER; WH-2

N.T.S.

SCHEDULE OF WATER HEATER

DESIGNATION	NAME	LOCATION	DESCRIPTION
WH-1	ELECTRIC TANK TYPE	AS NOTED	"STATE" EN6-40-DORS ELECTRIC TANK TYPE WATER HEATER, SIDE PIPING CONNECTIONS, 240V, 6000 WATTS, 55 GALLON FIRST HOUR RATING, 21 GALLONS PER HOUR RECOVERY @ 90° RISE

SCHEDULE OF FLOOR DRAINS AND FLOOR CLEANOUTS

DESIGNATION	NAME	LOCATION	DESCRIPTION
FD-1	FLOOR DRAIN	AS SHOWN	JR SMITH 2210 SERIES FLOOR DRAIN WITH SEDIMENT BUCKET

SCHEDULE OF HOSE BIBBS

DESIGNATION	SIZE	LOCATION	DESCRIPTION
HB-1	1/2"	AS NOTED	WOODFORD MODEL 24 ANTI-SIPHON WALL HYDRANT WITH TEE KEY
HB-2	1/2"	AS NOTED	WOODFORD MODEL 65 ANTI-SIPHON WALL HYDRANT WITH TEE KEY

ARLINGTON RENOVATIONS TO EXISTING BUILDINGS

ARLINGTON, MASSACHUSETTS

TOWN OF ARLINGTON

NO.	REVISION	DATE

kzla
Kylie Zick Landscape Architecture, Inc.
36 Bronfield Street Suite 202 Boston, MA 02108 617 451-1018 Tel www.kyiezick.com

bh+a
Bargmann Hendrie + Archetype, Inc.
9 Channel Center Street Boston, MA 02210 617 350-0450 Tel

CONSTRUCTION DOCUMENTS

Job Number:
Project: ARLINGTON RES.
Drawn By: KS Checked By: PP
Date: NOVEMBER 10, 2020
Scale:
Drawing Title:

Bathhouse Plumbing Schedules & Details

P200

**ARLINGTON
RENOVATIONS TO
EXISTING
BUILDINGS**
ARLINGTON, MASSACHUSETTS
TOWN OF ARLINGTON

1 GENERAL	headroom or space conditions appear inadequate, Architect shall be notified before proceeding with the installation.	K. Floor cleanouts: Cast iron, raised head caulking plug, brass cleanout cover flush mounted with flanged ring having anchor lugs, nickel-bronze scoriated hinged cover plate with "CO" cast in the cover, vanda-proof screws, similar to Zurn, Josam or Smith #4021. Access covers in all finished areas shall be similar to Zurn or Smith #4160 or 4200, with identical inlay of adjacent materials and vanda-proof screws.	3.4 VALVES
1.1 GENERAL PROVISIONS	1.8 SHOP DRAWINGS AND SUBMITTALS	L. Shock or water hammer arrestors: Shock or water hammer arrestors shall conform to the requirements of FDI-WP-201, ASSE 1010, or ANSI A112.26.1, size as required. Units shall be the standard factory prefabricated products as manufactured by Zurn or Jay R. Smith. Provide at urinals, hot water boosters, all clothes washer locations, and at the last fixture on all pipe runs exceeding twenty feet in length.	A. All piping systems shall be provided with valves so located that they can be operated, replaced, repaired and offer complete control to each group of fixtures, appliance, equipment, and each hot and cold water branch.
A. Attention is directed to the CONTRACT AND GENERAL CONDITIONS and all Sections within DIVISION 1 – GENERAL REQUIREMENTS, which are hereby made a part of this Section of the Specifications. B. Examine all other Sections of the Specifications for requirements, which affect work under this Section whether or not such work is specifically mentioned in this Section. C. The Plumbing Drawings shall not limit the Subcontractors responsibility to determine the full extent of his work as required by all Contract Drawings	A. Provide electronic copies of submittal data for approval to the architect. B. Shop drawings are required for: 1. Plumbing fixtures and equipment. 2. Pipe and fittings. 3. Valves. 4. Pipe insulation. 5. Drains and appurtenances. 6. Pipe hangers, supports and special equipment. 7. Water heaters and associated equipment.	M. Insulation: Insulation shall be installed in accordance with the requirements of the International Energy Conservation Code (IECC) and the manufacturer's instructions. Insulation shall be installed in accordance with the requirements of the International Energy Conservation Code (IECC) and the manufacturer's instructions.	B. Each fixture, appliance or piece of equipment shall have a separate shut-off valve, furnished and installed, of approved type, for service to be connected to. C. Locate valves on supply and return, at each piece of equipment or fixture, each side of regulating valves, each side of pumps, each side of meter, and on main branches. D. Drain valves on systems containing water shall be installed at the base of each riser (after the shut-off valve), on down-fed fixtures and at equipment, also at such other locations as required to allow for complete drainage of the system. E. Valves shall be located as shown on the drawings or as here-in-before specified.
1.2 GENERAL	1.9 SUBSTITUTIONS	2.4 HANGERS, SUPPORTS AND INSERTS	3.5 TESTING
A. All work shall be installed in accordance with the laws, ordinances, rules and regulations of all local and state authorities having jurisdiction, and the rules and regulations of the State Plumbing and Gas Codes. In case of conflict, the higher standard shall prevail. Extra payment will not be allowed for work or changes required by code enforcement authorities. B. Plumbing subcontractor shall apply and pay for inspection permits, certificates of inspection, and license fees in connection with this work, and deliver to the Owner at the completion of the work. All diagrams or drawings required by local or state authorities shall be supplied by This Contractor. C. Subcontract all portions of this work as necessary to avoid jurisdictional disputes and work stoppages that could arise during the installation of this work. D. All work shall be installed so that all parts required are readily accessible for inspection, operation, maintenance, and repair. Minor deviations from the drawings may be made to accomplish this end, but changes of magnitude shall not be made without prior written approval from the Architect. E. Plumbing subcontractor shall be responsible for work and equipment until finally inspected, tested, and accepted. Carefully store materials and equipment which are not immediately installed after delivery to the site. Close open ends of work with temporary covers or plugs during construction to prevent entry of obstructing material. F. The drawings show the extent and general arrangement of piping, and locations of the equipment. Piping, fixtures, and equipment are shown diagrammatically. This Contractor shall be responsible for the locations in the most practical manner, free from interference with other piping or structural features. G. It is the intention of these specifications and drawings to require the equipment to be furnished complete in every respect, and This Contractor shall furnish all equipment needed and usually supplied in connection with such systems. Equipment, materials and articles incorporated in the work shall be new, and of the best grade of their respective kinds for the type of work involved. H. Perform all tests, other than specified herein, which may be required by legal authorities or by agencies to whose requirements this work is to conform.	A. Substitutions of equipment or materials other than those shown on the drawings or named in the specifications may be made only with the written approval of the Engineer, who reserves the right to require adequate proof of the quality of the substitute before permitting its use.	A. Support all piping in accordance with the plumbing code.	A. The Plumbing Contractor shall test all plumbing systems in accordance with the plumbing code.
1.3 SCOPE OF WORK	2.5 ACCESS PANELS	2.6 INSULATION	3.6 CLEANING AND STERILIZATION OF SYSTEMS
A. Work Included: Provide labor, materials, and equipment necessary to complete the work of this section and, without limiting the generality thereof, including: 1. Modifications and additions to the existing sanitary drainage system. 2. Modifications and additions to the existing interior water systems, including cold and hot piping. 3. Demolition of existing plumbing fixtures and piping as indicated on the plans or as required to install new fixtures. 4. Complete hot water generation system. 5. Drainage specialties such as drains, cleanouts, vacuum breakers, shock absorbers, wall hydrants, hose bibs, etc. 6. Plumbing fixtures and all trim. B. Items to be Furnished Only: Furnish access panels to the General Contractor for distribution by him to the various trade sections in whose work the panels occur. C. Related work in Other Sections: 1. Cutting and patching. 2. Excavation, trenching and backfill. 3. All electric power wiring, except as specified herein. 4. Building heating, ventilating and air conditioning. 5. Flashing of floor drains and vents through the roof. 6. Toilet room accessories. 7. Installation of access panels. 8. Painting. 9. Sprinkler system. D. The Plumbing Contractor shall coordinate their scope of work with requirements as noted on architectural drawings.	A. Furnish access panels where required for access to plumbing equipment.	A. All new cold and hot water piping shall be insulated as indicated below. B. Existing piping insulation that is disturbed during construction shall be replaced with new. C. All insulation work shall be manufactured by Johns-Manville, Gustin-Bacon, Owens-Corning Fiberglass Corp. or equal, and be executed by a qualified Insulation Sub-contractor who is thoroughly experienced in this type of work, who has adequate facilities and equipment for erecting same; who is acceptable to the Architect. Application and finish on all pipes, fitting and valves shall be as recommended by manufacturer and approved by the Architect. Details shall be submitted for approval. All jackets and adhesives shall be flame retardant. Insulation shall be provided on all piping, valves and fittings in accordance with the International Energy Conservation Code and the requirements of this section. D. Hot water supply piping: 1. Piping – 1/2 inch thick for 1-1/2 inch piping and larger, 1/4 inch thick for 1-1/4 inch piping and smaller. Insulation shall be fibrous glass, 3-1/2 pound per cubic foot density minimum sectional pipe insulation with factory applied white All Service Jacket (ASJ) with butt strips and Benjamin-Foster, or equal BF95-75, or longitudinal seams. 2. Fittings and Valves - shall be insulated with insulation cement or molded fitting insulation to thickness of adjoining insulation finished with two coats of Benjamin-Foster, or equal "Foster Sealas" 30-36 lagging cloth. E. Cold water piping: 1. Piping – 1/2 inch thick for all piping. Insulation shall be fibrous glass, 3-1/2 pound per cubic foot density minimum sectional pipe insulation with factory applied white All Service Jacket (ASJ) with butt strips and Benjamin-Foster, or equal BF95-75, or longitudinal seams. No staples shall be utilized or accepted on the installation of the insulation on cold water piping. F. Fittings and Valves - shall be insulated with insulation cement or molded fitting insulation to thickness of adjoining insulation finished with two coats of Benjamin-Foster, or equal "Foster Sealas" 30-36 lagging cloth. G. All pipe insulation shall have a flame spread rating of 25.	A. The Plumbing Contractor shall be responsible for the cleaning and purging of all pertinent systems after installation and before system operation, in accordance with the plumbing code. B. All plumbing fixtures shall be thoroughly cleaned of all plaster, sticks, rust stains and other foreign matter or discoloration, leaving every part in an acceptable condition and ready for use. Surfaces shall be cleaned, polished and left bright. C. All finished metal work shall be cleaned, polished and left bright. All equipment, pipe, valves, drains and fittings shall be cleaned of grease, metal cutting and sludge, which may have accumulated during construction and/or testing. D. The Plumbing Contractor shall refresh and restore to its original condition all plumbing equipment which has sustained damage to the manufacturer's prime and finish coats of paint and/or enamel. E. The entire potable water system shall be thoroughly sterilized by the Plumbing Contractor with a solution containing not less than 50 parts per million of available chlorine. The chlorinating materials shall be either liquid chlorine conforming to the requirements of the U.S. Army Spec. No. 4-1 or sodium hypochlorite solution conforming to the requirements of Fed. Spec. C-B-441, Grade D. The sterilizing solution shall be allowed to remain in the system for a period of 8 hours, during which time all valves and faucets shall be opened and closed several times. After sterilization, the solution shall be flushed from the system with clean water until the residual chlorine content is not greater than 0.2 parts per million. Sterilization shall be to the satisfaction of the Board of Health. Submit certification, in writing, that this work has been accomplished in conformance with the above.
1.4 CODES, ORDINANCES AND PERMITS	1.10 GUARANTEE	2.7 PLUMBING FIXTURES	3.7 WINTERIZATION
A. All work shall be installed in accordance with the laws, ordinances, rules and regulations of all local and state authorities having jurisdiction, and the rules and regulations of the State Plumbing and Gas Codes. In case of conflict, the higher standard shall prevail. Extra payment will not be allowed for work or changes required by code enforcement authorities. B. Apply and pay for inspection permits, certificates of inspection, and license fees in connection with this work, and deliver to the Owner at the completion of the work. All diagrams or drawings required by local or state authorities shall be supplied by This Contractor. C. All equipment, fixtures, and valves shall be compliant with Lead Reduction NSF 61 2014 standard.	A. Attention is directed to the provisions of the GENERAL CONDITIONS and SUPPLEMENTARY CONDITIONS regarding guarantees and warranties for work under this contract. B. All materials, items of equipment and workmanship furnished under this section shall carry the standard warranty against all defects in material and workmanship. Any fault due to design which may develop shall be made good by and at the expense of This Contractor, including all other damage done to areas, materials and other systems resulting from this failure.	A. See plumbing fixture schedule for plumbing fixture selections. B. Mounting heights shall be as shown on architectural details. C. Fixture installation shall be in accordance with 521 CMR as required. D. Each individual fixture shall be provided with supply stops for each water service.	A. The building is not heated in the winter. All piping shall be installed with valves, drains and pitch that allow complete drain-down of the system to prevent freezing.
1.5 JURISDICTIONAL DISPUTES	2.1 PIPE AND FITTINGS	2.8 HOSE BIBBS	END OF SECTION
A. Subcontract all portions of this work as necessary to avoid jurisdictional disputes and work stoppages that could arise during the installation of this work.	A. Sanitary waste and vent piping systems above grade, within the building foundation walls: 1. No-hub cast iron with rubber gaskets and mechanical couplings or DWV copper with wrought copper drainage fittings with 95/5 lead-free solder joints. B. Sanitary waste and vent piping below grade: 1. Cast iron, bell and spigot with rubber gasket joints, service weight, coated on exterior. C. Water piping: 1. Underground domestic water: Ductile iron mechanical joint pipe, Class 51 conforming to ANSI A21.11 with mechanical joint fittings conforming to ANSI A21.10 or A21.11, or Type K or L copper tubing with cast brass fittings. 2. Above ground domestic water: a. Copper tubing, Type L, conforming to ASTM B-88 with solder joint wrought copper fittings conforming to ANSI B16.18 or B16.22, lead-free solder joints.	A. Interior hose bibbs shall be Woodford Model 24, Josam, or Zurn, chrome plated, vacuum breaker, hose connection, loose T key.	
1.6 INTENT	2.2 VALVES	2.9 FLOOR DRAINS	2.10 TRAP PRIMERS
A. It is the intention of these specifications and drawings to require the equipment to be furnished complete in every respect, and this Contractor shall furnish all equipment needed and usually supplied in connection with such systems. Equipment, materials, and articles incorporated in the work shall be new, and of the best grade of their respective kinds for the type of work involved.	A. Each valve type shall be of same manufacturer and appropriate for service in which used: valves shall be Milwaukee, Watts, or Apollo. Type proposed for each service shall be submitted for approval. In general, shut-off valves, except for exposed stops at fixtures, shall be ball valves. B. Each system shall be provided with valves as required by Code and as specified. Valves shall be installed for isolation and to facilitate operation, replacement, and repair. Provide access panels where valves are concealed behind non-removable ceilings or walls. Provide shut off valves for gas and water supply piping to individual fixtures and appliances. C. Valves shall be: 1. Ball valves - 2 inches and smaller, bronze, 400 lb., 1/4 turn solder ends for Type "L" tubing, Watts No. B-600I. 2. Ball valves - 3 inches and larger - 400 lb., 1/4 turn, bronze, threaded ends. 3. Check valves - 2 inches and smaller - brass, 125 lb., swing check, solder ends, Nibco #F-918. 4. Check valves - 2-1/2 inches and larger - bronze, 125 lb., swing check, flanged ends, Nibco #F-918. 5. Drain valves - cast bronze, 1/2" and 3/4", threaded outlet for garden type hose connection, Nibco #72.	A. Furnish and install all floor drains as indicated and required. Drains shall be Jay R. Smith or Zurn.	A. Furnish and install trap primers for floor drains as indicated and required. B. Refer to trap primer schedule for manufacturer and model. C. Provide access panels at all trap primer locations.
1.7 DRAWINGS	2.3 MISCELLANEOUS PIPING MATERIALS	2.11 WATER HEATER	2.16 WATER HEATER
A. The drawings show the extent and general arrangement of piping, and locations of the equipment. Piping, fixtures, and equipment are shown diagrammatically. This Contractor shall be responsible for the locations in the most practical manner, free from interference with other piping or structural features. If any changes from the drawings are deemed advisable, details of such proposed changes shall be submitted for approval. No changes shall be made without such approval. Maintain maximum headroom or space conditions at all points. Where	A. Nipples: Nipples shall conform to WW-N-351 and shall be the same material as the piping in which installed. B. Unions: Unions shall be brass or bronze, 125 lb., either threaded or with solder joint ends, conforming to WW-U-516 for use in copper tubing. For use in steel piping unions shall conform to WW-U-531. C. Insulating bushings and Unions: hard rubber threaded bushing inserted between two dissimilar metals. D. Flanges on copper tube or pipe: cast bronze, 150 lb., solder joint connection. E. Flanges on steel piping: carbon steel, 150 lb., welding neck or slip-on ASTM A181, Grade 1, ANSI B16.5 F. Floor and ceiling escutcheon plates: Floor and ceiling escutcheon plates shall be split hinged, locked type. Plates shall be of pressed steel with a heavy coating of copper, nickel and chromium. G. Copper: Copper for flashing shall be soft temper or light cold rolled, minimum weight 16 ounces per square foot. H. Sheet lead: Sheet lead for flashing shall be at least four pounds per square foot. I. End cleanout: Threaded brass tapered plug fitted with raised head for cast iron piping with plug fitted with raised head. J. Wall cleanouts: Chrome plated steel access panels, complete with frame and anchor straps, concealed hinges, slotted actuated cylinder lock installed flush with wall to gain access to valves and cleanouts. Access panels shall have general characteristics of Zurn, Josam, Smith #4761 or #4766.	A. Furnish and install water heaters as indicated in the water heater schedule.	A. The plumbing drawings intend to show only the scope of the design, and the Plumbing Contractor shall be responsible for the correct installation of his work in a manner satisfactory to the best practices of his trade and to complete the scope of this work in all respects. B. The contractor is responsible for field verifying all existing conditions for connections to existing systems, and shall modify the connection points as necessary based on existing conditions. C. The location of piping as indicated on the drawings is diagrammatic only, and the exact location shall be determined in the field. D. This Contractor shall be responsible for the correctness of field dimensions and shall check for himself all grades, lines, measurements, and other data in any way affecting his work. E. All exposed runouts to equipment, materials and fixtures having chrome plated trim and/or fittings shall be chrome plated brass with chrome plated brass fittings, unless otherwise noted.

NO.	REVISION	DATE

kzla
Kyle Zick Landscape Architecture, Inc.
36 Bromfield Street Suite 202 Boston, MA 02108 617 451-1018 Tel
www.kyzick.com

architect
bhrt
Bargmann Hendrie + Archetype, Inc.
9 Channel Center Street Boston, MA 02210 617 350-0450 Tel

CONSTRUCTION DOCUMENTS

Job Number:	
Project: ARLINGTON RES.	
Drawn By: KS	Checked By: PP
Date: NOVEMBER 10, 2020	
Scale:	
Drawing Title:	

Plumbing Name Specifications
P300

**ARLINGTON
RENOVATIONS TO
EXISTING
BUILDINGS**
ARLINGTON, MASSACHUSETTS

TOWN OF ARLINGTON

PART 1 - GENERAL

1.1 GENERAL CONDITIONS

- A. Division 1, General Conditions are hereby made part of this specification by reference.
- B. No materials or supplies for the work shall be purchased by the Contractor or by any Subcontractor subject to any chattel mortgage or under a conditional sale contract or other agreement by which an interest is retained by the seller. The Contractor warrants that he has good title to all materials and supplies used by him in the work, free from all liens, claims or encumbrances.
- C. Examine all Drawings and all sections of the Specifications affecting the work of this section.

1.2 GENERAL

- A. The HVAC Contractor shall coordinate with other contractors.
- B. Drawings are diagrammatic only, and do not necessarily show all required offsets, elbows and other fittings that may be required. Final routing or ductwork, piping and equipment locations shall be determined in the field.
 - 1. Changes to ductwork, piping and equipment that will be exposed shall be approved by the architect.
- C. The HVAC Contractor shall coordinate all electrical and plumbing requirements with the electrical and plumbing contractors.
- D. Refer to architectural plans for final locations of diffusers, registers, grilles and exposed ductwork.
- E. The HVAC Contractor shall furnish and install all incidental accessories necessary to make the HVAC work complete and ready for operation.
- F. All HVAC work shall be in accordance with applicable federal, state and local codes.
- G. The HVAC Contractor shall obtain and pay for all required permits and inspections.
- H. All equipment, materials and related system components shall be new unless specifically noted.
- I. All HVAC equipment shall be installed in accordance with the manufacturer's recommendations.
- J. The HVAC Contractor shall furnish to the General Contractor all information required for setting of wall, roof and partition openings for HVAC work. This information shall be furnished in a timely manner such that the construction schedule is not jeopardized.

1.3 GENERAL REQUIREMENTS FOR SHEETMETAL DUCTWORK

- A. All ductwork shall be constructed in accordance with the latest SMACNA standards.
- B. All ductwork indicated on the drawings is to be considered as shown in schematic. Changes in duct size to clear obstructions or to accommodate field conditions caused by the work of other trades, not shown on the drawings, shall be made, where necessary to conform to the actual space conditions and shall be provided at no additional cost to the owner. No duct changes shall be fabricated until after written approval of the modified or original shop drawings by the Engineer.
- C. It shall be this Contractor's responsibility to field verify all dimensions and to coordinate his work with the work of other trades. Locations and placement of ducts shall be coordinated with the work of the other trades before any ductwork is fabricated or installed.

1.4 SHOP DRAWINGS AND SUBMITTALS

- A. Provide copies of submittal data for approval to the architect as required in the General Conditions section of the specifications.
- B. Submit complete manufacturer's product description and technical information for the following:
 - 1. Fans
 - 2. Testing, Adjusting and Balancing information

1.5 SUBSTITUTION OF MATERIALS OR EQUIPMENT

- A. Named manufacturers for any equipment specified herein or identified on the drawings are identified for the purpose of identifying quality standards, performance information or type. Any substitution as "or equal" shall be considered. The Architect shall determine whether or not the offered equipment is equal to the specified. Where dimensional constraints exist the HVAC Sub-Contractor shall be responsible for any extra costs associated with extra work required to make the "or equal" equipment fit.

1.6 FEES AND PERMITS

- A. The HVAC Sub-Contractor and related Sub-Contractors shall apply for, obtain and pay for all required permits, inspections, certificates, and incidental charges required for proper performance of the work, and shall furnish the Architect with copies of applications and all correspondence.

1.7 OPERATION AND MAINTENANCE INSTRUCTIONS

- A. The contractor shall provide three (3) copies of an operations and maintenance manual, bound, indexed and titled in an 8 1/2"x11" post binder (not a three-ring loose-leaf type binder).
- B. The manual shall contain the following:
 - 1. Fans

1.8 WARRANTIES

- A. Submit manufacturers standard replacement warranties for material and equipment furnished under this Section. Such warranties shall be in addition to and not in lieu of all liabilities which the manufacturer and the HVAC Sub-Contractor and related Sub-Contractors may have by law or by provisions of the Contract Documents.
- B. Guarantee that all elements of each system meet the specified performance requirements as set forth herein or as indicated on the Drawings.
- C. Upon receipt of notice from the Owner of the failure of any part of the systems during the guarantee period, the affected parts shall be replaced. Any equipment requiring excessive service shall be considered defective and shall be replaced.

1.9 BALANCING

- A. The Contractor shall perform the services of testing, adjusting, and balancing of the heating, ventilating, and air conditioning systems.

- B. The Contractor shall check and adjust all HVAC systems to produce the performance specified by the construction documents and to achieve total system balance. The Contractor shall be certified by an appropriate air balance council.
- C. The Contractor shall furnish all certified engineers, instruments, and provide personnel, trained and experienced, to test, adjust and balance all airside systems and related automatic temperature control systems, and shall submit system performance reports.

1.10 DEMOLITION

- A. The HVAC Subcontractor is responsible for addressing items related to heating, cooling and ventilation system components noted on the plans as being "demolished" or "removed". The HVAC Subcontractor shall disconnect, drain and cap existing items shown to remain, and inactivate and disconnect from the building and from other equipment such items that are shown to be removed.
- B. The HVAC Subcontractor is responsible for removing all equipment, ductwork and piping supports where these items are removed, and through the point of connection to the building construction.
- C. Refer to Section 02 41 00 - Demolition for general requirements.

2 PART 2 - PRODUCTS

2.1 MATERIALS

- A. All materials, except as otherwise specified, shall be new, of current production, first quality and the best of each class specified.
- B. Required materials not covered by detailed specifications shall be of a suitable class, grade, quality and type and shall be subject to the approval of the Architect. Where two or more units of the same class of equipment are required, these units shall be the products of a single manufacturer.
- C. All equipment shall be installed and constructed to operate safely, as designed, without leakage, undue wear, noise, vibration or corrosion.

2.2 ROOF MOUNTED EXHAUST FANS

- A. Fans shall be equal to the fans indicated in the schedule.

3 PART 3 - EXECUTION

3.1 HVAC SUB-CONTRACTOR'S WARRANTY

- A. The HVAC Sub-Contractor shall provide a one year warranty against failure of the installed materials for any reason. The warranty shall cover the full costs of parts and labor required to remedy the defect, including, if necessary, replacement at the site, and shall run from the date of the Architect's acceptance of the system. The warranty shall also include provision for field inspection at no charge to the Owner, to verify failure, establish probable cause, and determine corrective action required. The HVAC Sub-Contractor shall furnish all service during the first year of operation. Any material, that in the opinion of the architect, requires excessive service during the first year of operation shall be considered defective and will be replaced by the HVAC Sub-Contractor at no charge to the Owner.
- B. The HVAC Sub-Contractor shall provide a listing of all manufacturers' commercial warranties provided by those manufacturers on their Materials. The list of these warranties must include the time period of each warranty. One copy each of those warranties shall be submitted with the listing.
- C. The HVAC Sub-Contractor shall be responsible for warranting the testing, adjusting and balancing work for a period of one year after final date of completion. The HVAC Sub-Contractor shall also be responsible for all damage to existing systems as a result of the work performed. All damaged systems shall be repaired or replaced at the option of the Owner at no additional cost to the Owner. All such repair or replacement work shall be done immediately upon finding.
- D. Warranty response to any malfunction shall be on a next day, normal working hour basis.
- E. Work under warranty shall be performed by fully qualified workmen and/or technicians.
- F. All guarantees and warranties required to be provided for the work in this Section shall begin their term on the date of final written acceptance of the entire system by the Owner.

3.2 PERFORMANCE

- A. The drawings are diagrammatic and the final arrangement of the work shall suit the existing and field conditions, the characteristics of the materials used and the instructions of the Engineer and/or the Architect.
- B. The HVAC Sub-Contractor shall be responsible for repair of damaged or disturbed existing work or the work of other trades caused by his work, testing of his work or repair to his work.
- C. All devices shall be installed in accordance with the manufacturer's recommendations, the Engineer's instructions and so as to provide all required access for cleaning, operation, repair and maintenance.

3.3 FINAL ACCEPTANCE

- A. The HVAC Sub-Contractor shall leave all system components in proper working order, such as belt guards in place, access doors closed, doors to electrical switch boxes closed, thermostats restored to specified setting. All recorded data shall represent a true, actually measured, or observed condition. Any abnormal conditions in the mechanical systems or conditions that prevent total system balance shall be reported to the Architect immediately upon finding. The HVAC Sub-Contractor shall permanently mark all dampers and other adjustment devices in a manner that will allow the settings to be restored.
- B. The HVAC Sub-Contractor shall verify that all air systems are in compliance with all standards, such as ASHRAE minimum outside air, and all other applicable codes and requirements.
- C. The HVAC Sub-Contractor shall make any necessary changes in fan speed.

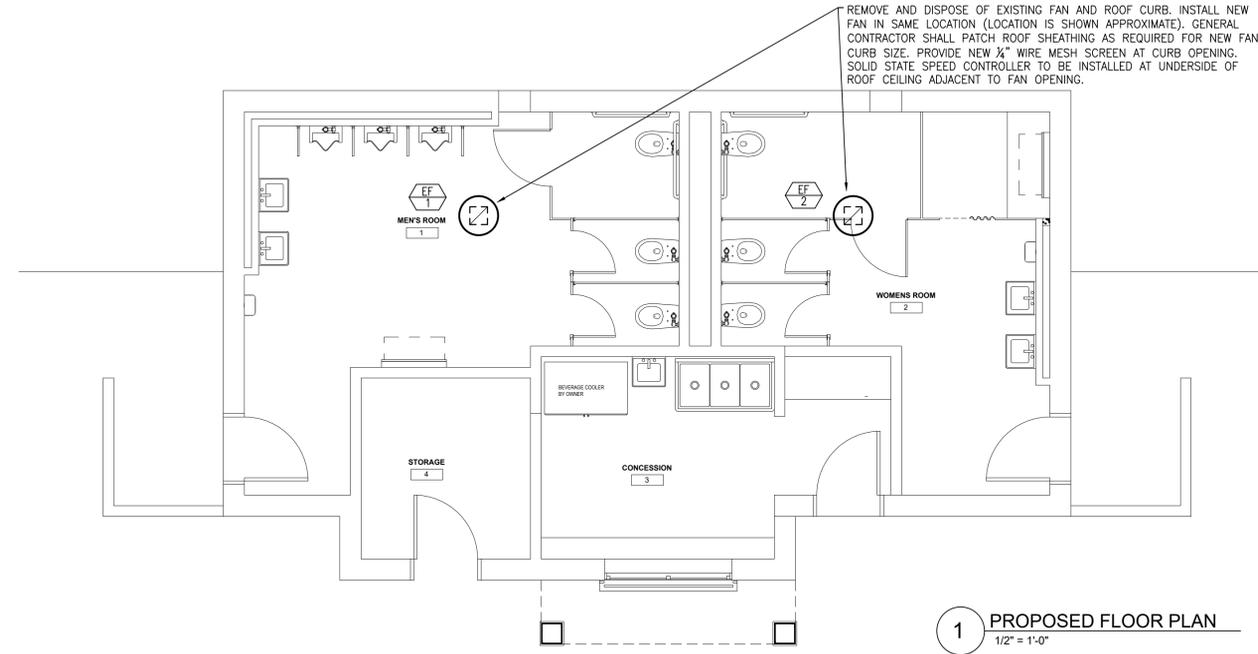

1 PROPOSED FLOOR PLAN
1/2" = 1'-0"

FANS SCHEDULE

TAG	SERVICE	CFM	HP	SP (IN)	RPM	VOLTAGE	MANUFACTURER / MODEL NO.	WEIGHT	REMARKS
EF-1	MENS	300	1/15	0.25	1057	120/1/60	GREENHECK / G-090-D	-	ROOF CURB FOR PITCHED ROOF, BIRD SCREEN, SOLID STATE SPEED CONTROLLER, CONTROLLED BY WALL SWITCH
EF-2	WOMENS	300	1/15	0.25	1057	120/1/60	GREENHECK / G-090-D	-	

NO.	REVISION	DATE

kzla
Kyle Zick Landscape Architecture, Inc.
36 Bromfield Street Suite 202
Boston, MA 02108
617 451-1018 Tel
www.kyezick.com

bhta
Bargmann Hendrie + Archetype, Inc.
9 Channel Center Street
Boston, MA 02210
617 350-0450 Tel

CONSTRUCTION DOCUMENTS

Job Number:	
Project: ARLINGTON RES.	
Drawn By: JW	Checked By: JW
Date: NOVEMBER 10, 2020	
Scale:	
Drawing Title:	

Bathroom HVAC
Sheet Name
Plan

H100

GENERAL NOTES

- THE SIZES OF ELECTRICAL RACEWAY SHALL BE AS INDICATED ON THE CONTRACT DRAWINGS AND SHALL MEET THE REQUIREMENTS OF THE LOCAL AUTHORITY HAVING JURISDICTION.
- MINIMUM WIRE SIZE SHALL BE #12 SOLID AWG FOR 20A LIGHTING/RECEPTACLE BRANCH CIRCUIT; #12 AWG SOLID FOR #20A APPLIANCE BRANCH CIRCUITS; #10 SOLID AWG FOR 30A DRYER BRANCH CIRCUIT; #8 STRANDED AWG FOR 40 TO 50A RANGE CIRCUIT.
- MINIMUM WIRE SHALL BE #12 FOR BRANCH CIRCUIT RUNS UP TO 100' TO THE LAST OUTLET; OVER 100'-#10; OVER 150'-#8 AND INCREASE CONDUIT SIZE AS REQUIRED BY LOCAL ELECTRICAL CODE.
- ALL WIRING INSTALLATION SHALL BE COLOR CODED AS PER CODE. CONDUCTORS SIZED #10 AND LOWER SHALL BE SOLID; #8 AND HIGHER STRANDED.
- ALL WIRING DEVICES, PANEL BOARDS, DISTRIBUTION BOARDS, MOTORS, ETC., SHALL BE GROUNDED AS PER LOCAL ELECTRIC CODE.
- ALL WORK SHALL BE INSTALLED IN FULL ACCORDANCE WITH LOCAL CODES, STATE AND LOCAL AUTHORITIES. FILE ALL PLANS, OBTAIN ALL PERMITS, PAY ALL FEES, SCHEDULE ALL INSPECTIONS, MAKE ALL TESTS AND OBTAIN ALL APPROVALS REQUIRED. THE ELECTRICAL WORK SHALL BE PERFORMED IN ACCORDANCE WITH THE LATEST EDITION OF NATIONAL ELECTRIC CODE AND LOCAL AUTHORITIES HAVING JURISDICTION. ALL COMPONENTS SHALL BE UL APPROVED AND LISTED.
- WHERE CONFLICTS ARE FOUND BETWEEN DRAWINGS, SPECIFICATIONS, & LAWS & ORDINANCES, THE MOST STRINGENT SHALL APPLY.
- SUBMIT FOR APPROVAL, COMPLETE SHOP DRAWINGS, LIST OF MATERIALS AND DETAILED DATA OF EQUIPMENT GIVING THE MANUFACTURERS NAME, CATALOG NUMBER, SIZE, CAPACITY AND DIMENSIONS. NO EQUIPMENT SHALL BE INSTALLED OR FABRICATED WITHOUT OBTAINING APPROVAL.
- ALL MOTORS SHALL BE SUPPLIED WITH MOTOR STARTERS BY OTHERS UNLESS CLEARLY INDICATED OTHERWISE ON THE CONTRACT DOCUMENTS. SHORT CIRCUIT PROTECTION SHALL BE BY MCP OR FUSED DISCONNECT SWITCH AS SHOWN OR SPECIFIED.
- MANUALLY CONTROLLED SINGLE PHASE MOTORS SHALL HAVE FULLY RATED MANUAL MOTOR STARTER SWITCHES WITH O.L. HEATERS IN EACH UNGROUNDED LEG.
- CIRCUIT RUNS ARE SHOWN DIAGRAMMATICALLY ONLY AND SHALL BE INSTALLED IN A MANNER TO PREVENT CONFLICTS WITH EQUIPMENT AND STRUCTURAL CONDITIONS. CONDUITS AND CABLES SHALL BE INSTALLED PARALLEL TO BEAMS AND WALLS.
- CABLES/CONDUCTORS SHALL BE TERMINATED SO AS TO PERMIT NEAT CONNECTIONS TO MOTORS AND OTHER EQUIPMENT.
- THE QUANTITY AND SIZE OF WIRES AND CONDUIT SHOWN ON DRAWINGS AND WIRING DIAGRAMS REPRESENT A SUGGESTED ARRANGEMENT BASED UPON SELECTED STANDARD COMPONENTS OF ELECTRICAL EQUIPMENT. MODIFICATIONS ACCEPTABLE TO THE ENGINEER MAY BE MADE BY THE CONTRACTOR TO ACCOMMODATE EQUIPMENT ACTUALLY PURCHASED. THE BASIC SEQUENCE AND METHOD OF CONTROL MUST BE MAINTAINED AS INDICATED ON THE DRAWINGS.
- SWITCHES SHALL BE MOUNTED 4'-0" MAX ABOVE FINISHED FLOOR UNLESS OTHERWISE NOTED. RECEPTACLES SHALL BE MOUNTED 1'-6" ABOVE FINISHED FLOOR UNLESS OTHERWISE NOTED.
- ALL PANELBOARDS SHALL BE MOUNTED SO THAT THE DISTANCE FROM THE TOP CIRCUIT BREAKER OPERATING HANDLE TO THE FLOOR SHALL NOT EXCEED 6'-7".
- REFER TO ARCHITECTURAL DRAWINGS FOR EXACT LIGHT FIXTURE LOCATIONS. LIGHTING FIXTURES SHALL BE MOUNTED ACCORDING TO THE MOUNTING HEIGHT GIVEN ON THE ARCHITECTURAL DRAWINGS, WITH THE DISTANCE BEING MEASURED FROM THE BOTTOM OF THE LIGHTING FIXTURE TO THE FINISHED FLOOR.
- THE HVAC CONTROL EQUIPMENT AND MISCELLANEOUS DEVICES, OUTLET, SWITCHES, JUNCTION, PULL AND TERMINAL BOXES SHALL BE PROVIDED WITH NEMA ENCLOSURE SUITABLE TO THE ENVIRONMENT.
- CONDUIT FOR WIRING CONCEALED IN FLOOR SLABS, OR BELOW GRADE SHALL BE 1" MINIMUM PVC.
- CONFIRM EXACT POWER REQUIREMENTS AND CONNECTION LOCATIONS FOR ALL EQUIPMENT PRIOR TO INSTALLATION WITH PLUMBING/HVAC AND GENERAL CONTRACTOR.
- COORDINATE THE CENTER-LINE OF ALL OUTLET BOXES, SPECIFIC LOCATION AND ROUGH WIRING PRIOR TO INSTALLING DEVICES FOR ALL APPLIANCES AND EQUIPMENT. REFER TO THE ARCHITECTS DRAWINGS AND MANUFACTURERS SPECIFICATIONS FOR SPECIFIC REQUIREMENTS.
- WORK SHALL COORDINATE WITH THAT OF OTHER TRADES TO MINIMIZE CONFLICTS AND ELIMINATE INTERFERENCES.
- EXACT LOCATION OF MECHANICAL AND PLUMBING SYSTEM EQUIPMENT SHALL BE VERIFIED WITH THE APPROPRIATE CONTRACTOR PRIOR TO INSTALLING THE SYSTEMS.
- ALL WORK SHALL BE DONE IN A NEAT AND WORKMANLIKE MANNER AND THE CONTRACTOR SHALL KEEP HIS PORTION OF THE WORK CLEAN AND ORDERLY.
- ALL 20A; GFCI RECEPTACLES INSTALLED OUTDOORS IN WET OR DAMP LOCATIONS SHALL BE LISTED WEATHER-RESISTANT.
- PROVIDE RAIN-TIGHT WHILE IN USE COVERS ON ALL OUTDOOR GFCI RECEPTACLES.
- ALL EXTERIOR DISCONNECTS ARE TO BE NEMA-3R.

LIGHTING SCHEDULE GENERAL NOTES (SCHEDULE ON SHEET E2.0):
ALL FIXTURES INSTALLED IN OR AROUND FIRE RATED OR IC RATED ASSEMBLIES ARE TO BE EQUIPPED WITH RATED BOXES BY TENMAT (SIZE TO SUIT FIXTURE) IF NOT INHERENTLY RATED.

THE ELECTRICAL CONTRACTOR IS TO VERIFY THE VOLTAGE OF THE FIXTURE WITH THE CIRCUIT AVAILABLE PRIOR TO ORDERING.

MOUNTING HEIGHTS, MOUNTING OPTIONS, FINISHES AND OPTIONS ARE TO BE APPROVED AND COORDINATED WITH THE ARCHITECT PRIOR TO ORDERING THE FIXTURES.

FIXTURES SHOWN ON ARCHITECTURAL PLANS OVER-RIDE THOSE SHOWN ON THE ELECTRICAL PLAN. REVIEW BOTH PLANS AND PROVIDE THE LARGER QUANTITY OF EACH TYPE.

CLARIFICATION IS TO BE OBTAINED, PRIOR TO BID, REGARDING ANY QUESTIONS RELATED TO THE LIGHTING SYSTEM.

THE E.C. IS TO COMPLETE THE INSTALLATION OF ANY ADDITIONAL LIGHTING CONTROLS SUCH AS OCCUPANCY SENSORS, ETC. THAT ARE INCLUDED WITH THE FIXTURE PACKAGE.

ALL LAMPING AND FIXTURE WHIPS ARE TO BE INCLUDED.

BRANCH CIRCUIT WIRING

- ALL BRANCH CIRCUIT WIRING SHALL BE COPPER - TYPE AS LISTED IN THE SPECIFICATIONS UNLESS OTHERWISE NOTED.
- FOR CLARITY, ALL BRANCH CIRCUIT WIRING IS NOT SHOWN, HOWEVER A COMPLETE BRANCH CIRCUIT WIRING SYSTEM IS TO BE INSTALLED IN ACCORD WITH THE DEVICES AND CIRCUIT NUMBERS SHOWN.
- WIRING SHOWN ON DRAWINGS IS FOR SPECIFIC ROUTES OR SPECIAL CONDITIONS
- ALL BRANCH CIRCUITS SHALL HAVE DEDICATED NEUTRALS. NO SHARED NEUTRALS WILL BE ALLOWED. A GREEN GROUNDING CONDUCTOR SHALL BE RUN WITH ALL CIRCUITS.
- TYPICAL CIRCUITING
"A" - "A" DENOTES FIXTURE TYPE, "P1A,33" DENOTES PANEL & CIRCUIT NUMBER, "b" DENOTES SWITCH CONTROL ALTERNATIVELY CIRCUITING MAY BE LOOPED

MEP COORDINATION

- ALL ELECTRICALLY POWERED HVAC, PLUMBING AND FIRE PROTECTION EQUIPMENT SHALL BE PROVIDED WITH LOCAL DISCONNECT SWITCHES. THE SWITCHES SHALL BE PROVIDED BY THE E.C. UNLESS NOTED OTHERWISE.
- ALL MOTOR STARTERS SHALL BE FURNISHED BY THE HVAC, PLUMBING OR FIRE PROTECTION SUBCONTRACTOR (TO DIVISION 16 SPECIFICATION REQUIREMENTS). INSTALLED AND WIRED BY THE E.C. STARTERS WILL BE MAGNETIC ACROSS THE LINE (AMBIENT COMPENSATED MOTOR OVERLOAD HEATERS IN ALL CURRENT CARRYING CONDUCTORS) WITH HOA SWITCH, MANUAL TOGGLE TYPE FOR SINGLE PHASE MOTORS WHICH DO NOT REQUIRE AUTOMATIC CONTROL.
- SPEED CONTROL: LINE VOLTAGE SPEED CONTROL SWITCHES FOR FRACTIONAL HORSEPOWER MOTORS THAT REQUIRE SPEED CONTROL SHALL BE SUPPLIED BY THE HVAC CONTRACTOR AND INSTALLED AND WIRED BY THE E.C.
- THERMOSTATS ARE SHOWN ON THE MECHANICAL PLAN - PROVIDE FOR EACH THERMOSTAT PER THE LEGEND (⊕ SYMBOL).
- ALL DISCONNECTS FOR MECHANICAL UNITS ARE TO BE MOUNTED SECURELY TO THE FLOOR / STRUCTURE. THE ELECTRICAL CONTRACTOR IS TO PROVIDE AND INSTALL UNISTRUT AND MOUNTING HARDWARE AS REQUIRED TO MOUNT THE DISCONNECTS.

LIGHTING LEGEND

SYMBOLS	DESCRIPTION
\$	20A, 120/277 VAC SINGLE POLE, TOGGLE SWITCH - FLUSH WALL MOUNTED.
\$3	3-WAY SWITCH
—	LIGHTING CONTROLS
F1	2x4 FLUORESCENT LIGHTING FIXTURE CEILING OR RECESSED MOUNTED. "F1" INDICATES FIXTURE TYPE, "LP,2" INDICATES CIRCUIT NUMBER, "a" INDICATES SWITCH CONTROL
○	ROUND FIXTURE - SEE FIXTURE SCHEDULE FOR EXACT TYPE
○	WALL MOUNTED FIXTURE
□	SURFACE MOUNTED FIXTURE - SEE SCHEDULE FOR EXACT TYPE
\$U	WALL MOUNTED ULTRASONIC MOTION DETECTOR/SENSOR, SINGLE CIRCUIT - USE WATSTOPPER UW-100 OR APPROVED EQUAL MANUFACTURER
⊕	DUAL TECHNOLOGY OCCUPANCY SENSOR WITH SYMETRIC DISTRIBUTION WITH POWER PACK AND MOUNTING ACCESSORIES - USE WATSTOPPER #01-300 OR APPROVED EQUAL MANUFACTURER
⊕	FIXTURE TYPES AS SCHEDULED IN THE LIGHTING SCHEDULE.

COMMUNICATIONS LEGEND

SYMBOLS	DESCRIPTION
▽	DATA/TELEPHONE OUTLET WITH 3/4" CONDUIT AND (2) CAT-6 CABLES (TERMINATED ON BOTH ENDS) RUN TO THE TELEPHONE BACKBOARD

LIGHTING GENERAL NOTE:
REFER TO ARCHITECTURAL DOCUMENTS FOR EXACT FIXTURE LOCATIONS - ARCHITECTURAL LOCATIONS OVER-RIDE THE LOCATIONS SHOWN ON THE ELECTRICAL PLANS.

POWER LEGEND

SYMBOLS	DESCRIPTION
⊕	20A, 125 VAC 2P., 3W., GROUNDING TYPE, DUPLEX RECEPTACLE. FLUSH WALL MOUNTED.
⊕	20A, 125 VAC 2P., 3W., GROUNDING TYPE, DOUBLE DUPLEX RECEPTACLE. FLUSH WALL MOUNTED.
⊕ X	RECEPTACLE, DUPLEX GFCI
⊕ WP	DUPLEX GFCI RECEPTACLE MOUNTED 6" ABOVE COUNTER
⊕ WP	DUPLEX GFCI RECEPTACLE WITH WEATHER PROOF COVER/BOX
⊕	SPECIALTY OUTLET, MATCH OUTLET TYPE TO EQUIPMENT
—	SURFACE PANEL - SEE RESPECTIVE SCHEDULE.
—	FLUSH PANEL - SEE RESPECTIVE SCHEDULE.
↓	HOMERUN TO PANEL
⊕	FUSED DISCONNECT SWITCH, FUSE SIZE TO MATCH MFR. RECOMMENDATIONS
⊕	NONFUSABLE DISCONNECT SWITCH
⊕	SAFETY SWITCH, HORSEPOWER RATED
⊕	JUNCTION BOX
⊕	FAN
⊕	MOTOR
⊕	PUMP
⊕	CONNECTION TO GROUND
⊕	120 VOLT CARBON MONOXIDE DETECTOR - LOCAL ALARM ONLY
⊕	ELECTRICITY USAGE METER

LIGHT FIXTURE SCHEDULE

KEY	MANUF.	CATALOG NO
AA	EUREKA	3419-LED-35-80-120-DV-EMB-FINISH-3981EA (WITH EMERGENCY)
C (-EMB)	LITHONIA	FEM-L48-6000LM-IMAFL-MD-MVOLT-GZ10-35K-80CRI-MOUNT (-BE6WCP FOR EMB)
D	GOTHAM	EV04SH-35K-07-DFF-SMO-MVOLT-EZ10
CF1	KICHLER	330150MWH-WITH NO LED LIGHT (INCLUDE PLATE FOR COVER)
CF2	LEADING EDGE	48201-28002-MOUNT (WITH CAGE)

GENERAL NOTES:

- COORDINATE THE CENTER-LINE OF ALL OUTLET BOXES, SPECIFIC LOCATION AND ROUGH WIRING PRIOR TO INSTALLING DEVICES FOR ALL EQUIPMENT AND DEVICES. REFER TO THE ARCHITECTS DRAWINGS AND MANUFACTURERS SPECIFICATIONS FOR SPECIFIC REQUIREMENTS.
- MAIN ELECTRIC SERVICE SHALL BE INSTALLED AS SHOWN ON THE PLANS. UTILITY METER STANDARDS SHALL BE FOLLOWED ALONG WITH THE NATIONAL ELECTRIC CODE, STATE AND LOCAL REQUIREMENTS. VERIFY INSTALLATION REQUIREMENTS WITH UTILITY REPRESENTATIVE PRIOR TO ROUGH-IN.
- WORK SHALL COORDINATE WITH THAT OF OTHER TRADES TO MINIMIZE CONFLICTS AND ELIMINATE INTERFERENCES.
- THE CONTRACTOR SHALL VISIT THE SITE TO DETERMINE THE EXTENT OF WORK TO BE PERFORMED PRIOR TO BIDDING AND VERIFY ANY DIMENSIONS OF RELEVANT WORK TO BE BID.
- ALL WORK SHALL BE DONE IN A NEAT AND WORKMANLIKE MANNER AND THE CONTRACTOR SHALL KEEP HIS PORTION OF THE WORK CLEAN AND ORDERLY.
- ALL WORK SHALL CONFORM TO THE MASS ELECTRICAL CODE, NATIONAL ELECTRIC CODE AND THE LOCAL AUTHORITIES HAVING JURISDICTION.
- PROVIDE SLEEVES IN WALLS AND FOUNDATION WALLS REQUIRED TO INSTALL THE WORK SHOWN ON THE DRAWINGS.

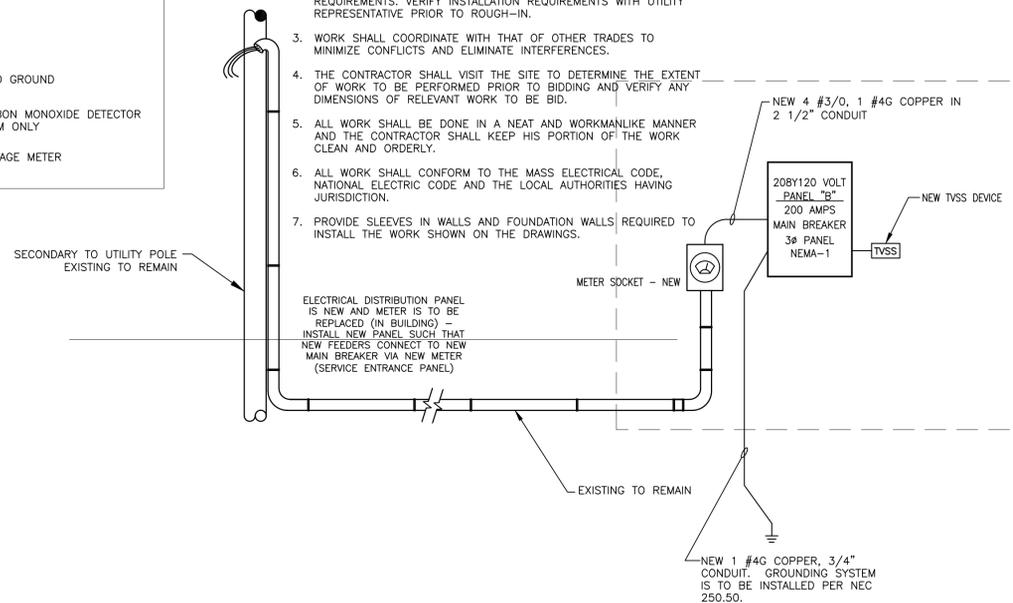

PANEL "B" SCHEDULE		VOLTAGE: 208Y120 VOLT - 3 PH. - 4 WIRE		200 AMP MAIN BREAKER** ; SURFACE MOUNTED						
CKT NO.	LOAD DESCRIPTION	WIRE	BREAKER	CONN. LOAD (KVA)	BREAKER WIRE	LOAD DESCRIPTION	CKT NO.			
φ	POLE	AMP	PH. "A"	PH. "B"	PH. "C"	AMP	POLE			
1	BEVERAGE COOLER	12	1	20		20	1	12	LIGHTING - WOMENS/UTILITY/CONS	2
3	CONCESSION OUTLETS	12	1	20		20	1	12	LIGHTING - MENS	4
5	CONCESSION OUTLETS	12	1	20		20	1	12	CEILING FANS	6
7	BATHROOM OUTLETS	12	1	20		20	1	12	CEILING FANS	8
9	EXTERIOR LIGHTING	12	1	20	0.2	40	2	8	SPARE	10
11	STORAGE OUTLETS	12	1	20						12
13	HAND-DRYER RECEPTACLE - WOMEN	12	1	20		20	1	12	EXHAUST FAN-1	14
15	HAND-DRYER RECEPTACLE - MEN	12	1	20	3.7	20	1	12	EXHAUST FAN-2	16
17	EJECTOR PUMP	10	2	30	9.0 3.7	20	1		SPARE	18
19	" "				9.0 3.7	20	1		SPARE	20
21	LIGHTING - EXTERIOR	12	1	20	9.0 5.8	20	1		SPARE	22
23	WATER HEATER	10	2	30	0.6 5.8	20	1		SPARE	24
25	" "				0.6 5.8	20	1		SPARE	26
27	SPARE				0.1	20	1		SPARE	28
29	SPARE				0.7	20	1		SPARE	30
31	SPARE				0.1	20	1		SPARE	32
33	SPARE					20	1		SPARE	34
35	SPARE					20	1		SPARE	36
37	SPARE				0.2	30	3	10	TVSS (INTERNAL)	38
39	SPARE				0.2					40
41	SPARE				0.2					42
TOTALS PER PHASE				12	12	12				
TOTAL LOAD						79.3				
* GFCI BREAKER						** MAIN BREAKER SIZE TO MATCH SERVICE FEEDERS				

ANY EXISTING CIRCUITS IN THE EXISTING PANEL THAT ARE FEEDING CIRCUITS THAT ARE TO REMAIN (ELSEWHERE ON-SITE) ARE TO BE RECONNECTED TO THE NEW BREAKERS LABELED "SPARE". EXTEND THE FEEDERS VIA SPLICE BOX WITH WIRE AND CONDUIT SIZED TO MATCH EXISTING.

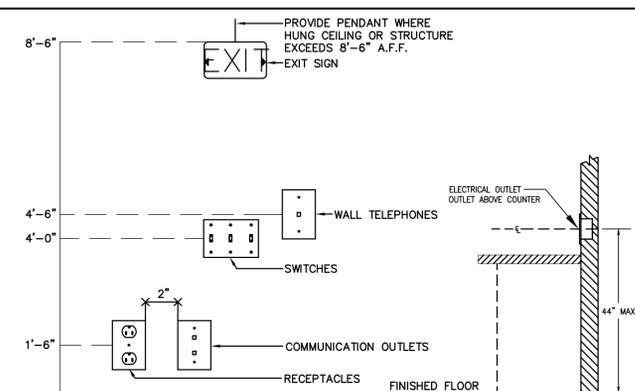

NOTES

- ALL MOUNTING HEIGHTS SHALL BE MEASURED FROM FINISHED FLOOR TO CENTERLINE OF DEVICE EXCEPT EXIT SIGNS
- DEVICES SHALL BE INSTALLED ON A COMMON VERTICAL CENTERLINE WHEREVER POSSIBLE.
- ALL DEVICES SHALL BE INSTALLED AT MOUNTING HEIGHTS AS INDICATED ON THIS DETAIL UNLESS OTHERWISE NOTED.
- REFER TO THE ARCHITECTS ELEVATION DETAILS FOR EXACT HEIGHT AND LENGTH OF SURFACE RACEWAYS.

MOUNTING HEIGHT DETAIL

N.T.S.

ARLINGTON RENOVATIONS TO EXISTING BUILDINGS

ARLINGTON, MASSACHUSETTS

TOWN OF ARLINGTON

NO. REVISION DATE

kzla
Kyle Zick Landscape Architecture, Inc.
36 Bromfield Street Suite 202
Boston, MA 02108
617 451-1018 Tel
www.kyzick.com

architect
bhta
Bargmann Hendrie + Archetype, Inc.
9 Channel Center Street
Boston, MA 02210
617 350-0450 Tel

CONSTRUCTION DOCUMENTS

Job Number:
Project: ARLINGTON RES.
Drawn By: RB Checked By: AP
Date: NOVEMBER 10, 2020
Scale:
Drawing Title:

Bathhouse
Electrical Legend,
Sheet Name
Details & Notes

E000

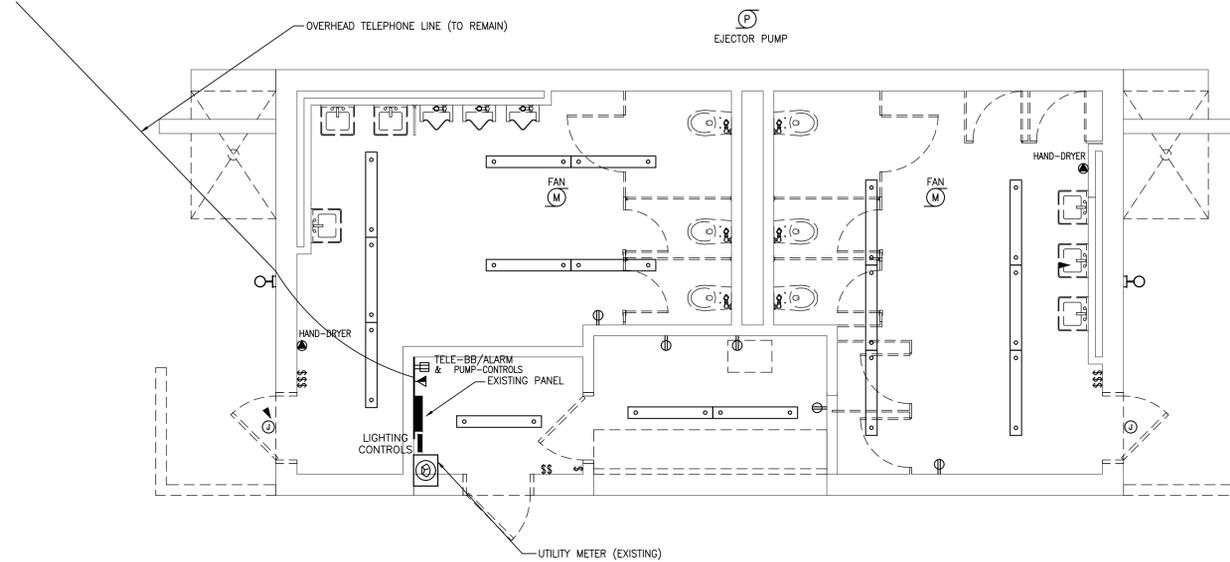

ELECTRICAL DEMOLITION GENERAL NOTES:

- ALL RECEPTACLES, DATA OUTLETS, AND HVAC DISCONNECTS, ETC. IN THE AREA OF WORK ARE TO BE REMOVED UNLESS OTHERWISE NOTED ON THE PLAN. THE ASSOCIATED WIRING IS TO BE MADE-SAFE AND REMOVED BACK TO THE SOURCE. WIRING IS TO BE LABELED WITH CIRCUIT NUMBERS AND PANEL IDENTIFIERS.
- INTERIOR LIGHTS AND CORRESPONDING SWITCHES IN THE AREA OF WORK ARE TO BE REMOVED UNLESS OTHERWISE NOTED. FIXTURES ARE TO BE DISPOSED OF IN A MANNER APPROVED BY THE ENVIRONMENTAL PROTECTION AGENCY OR REUSED (SEE NOTES ON PLAN). THE ASSOCIATED WIRING & CONTROLS ARE TO BE REMOVED BACK TO THE ELECTRICAL PANEL.
- ALL UNUSED WALL BOXES (LEFT FROM SWITCHES REMOVED, RECEPTACLES, ETC.) ARE TO BE REMOVED.
- ALL HOLES LEFT BY REMOVED FIXTURES, BOXES, ETC. ON EXISTING-TO-REMAIN WALLS AND CEILINGS ARE TO BE FILLED AND FINISHED TO MATCH NEW/EXISTING CONDITIONS BY THE GENERAL CONTRACTOR.
- ALL ELECTRICAL WORK IN THE SPACES SERVED OUTSIDE THE AREA OF WORK INCLUDING EMERGENCY LIGHTING, CONDUITS ARE EXISTING TO REMAIN. WORK IS TO BE SECURED AND PROTECTED AND TO REMAIN PER EXISTING CONDITIONS.
- THE E.C. IS TO PERFORM A WALK-THROUGH OF THE BUILDING PRIOR TO PRICING AND VERIFY THE EXACT WORK REQUIRED FOR DEMOLITION SERVICES IN THE AREA OF WORK.
- ALL PENETRATIONS (NEW AND EXISTING) OF THE FIRE RATED BARRIERS SHALL BE FIRE STOPPED USING U.L. APPROVED METHODS AND MATERIALS.
- SAFE DISCONNECTION OF ELECTRICAL UTILITIES IS TO BE PERFORMED BY THE ELECTRICAL CONTRACTOR FOR WORK IN THIS AREA.
- EXACT LOCATIONS FOR EXISTING LIGHT FIXTURES, DEVICES, AND BOXES ARE TO BE FIELD VERIFIED PRIOR TO BID. ALL ITEMS TO BE DEMOLISHED ARE NOT NECESSARILY SHOWN ON THIS PLAN.
- IT IS INTENDED THAT ALL NEW CONDUIT, WIRE, DISCONNECTS, ETC. ARE TO BE INSTALLED TO THE NEW WORK & HVAC AND MECHANICAL EQUIPMENT. ANY UNUSED OR ABANDONED DISCONNECTS, WIRE, CONDUIT, ETC. FOR REMOVED EQUIPMENT ARE TO BE COMPLETELY REMOVED BY THE COMPLETION OF THE DEMO-WORK.
- ALL UNUSED / ABANDONED ELECTRICAL WORK SHALL BE COMPLETELY REMOVED AS PART OF THE SCOPE.
- COORDINATE ITEMS TO BE SALVAGED WITH THE OWNER PRIOR TO DEMOLITION.

1 DEMO FLOOR PLAN
 1/2" = 1'-0"

ALL DEVICES TO REMAIN ARE TO REMAIN ACTIVE EVEN WHEN A DEVICE TO REMAIN SHARES A COMMON CIRCUIT WITH A DEVICE TO BE REMOVED.

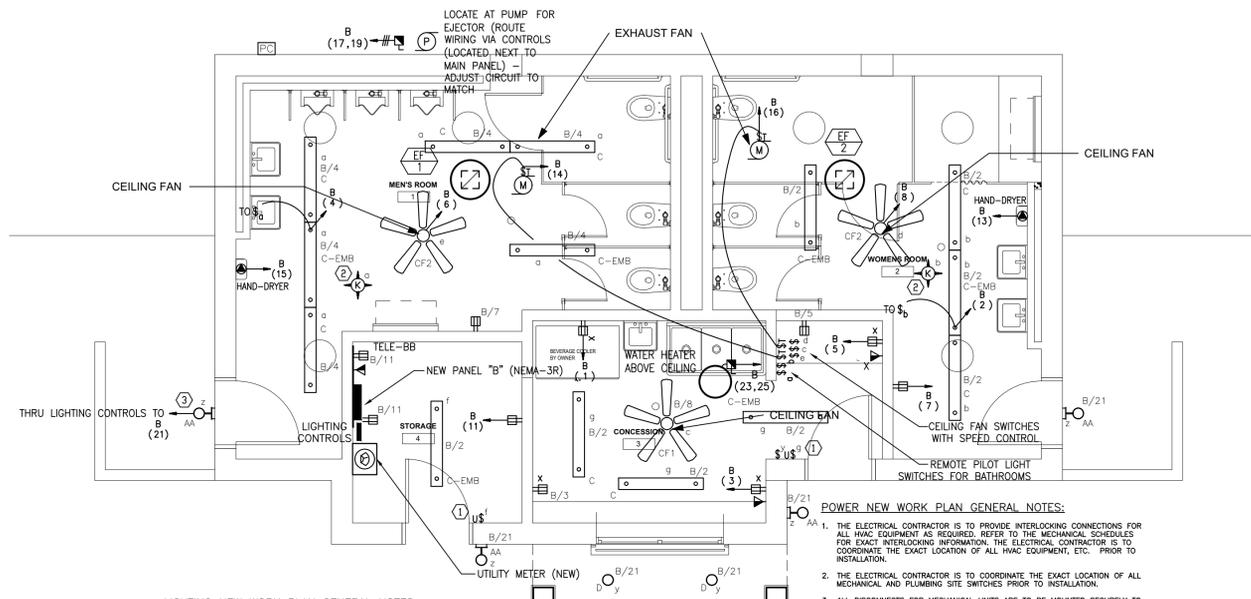

LIGHTING NEW WORK PLAN GENERAL NOTES:

- LIGHTING CONTROLS (TIMERS AND OCCUPANCY SENSORS) ARE TO BE INSTALLED PER MANUFACTURER'S RECOMMENDATIONS.
- ALL LIGHT FIXTURES LOCATIONS ARE TO BE COORDINATED WITH ARCHITECTURAL PLANS. LIGHT FIXTURE LOCATIONS ARE TO BE COORDINATED WITH DUCTWORK, EQUIPMENT, ETC.
- EMERGENCY CIRCUITS POWERING EMERGENCY BATTERY UNITS SHALL BE UNSWITCHED/UNCONTROLLED.

LIGHTING NEW WORK PLAN KEYNOTES:

- THE TIMERS ON THIS CIRCUIT ARE TO BE PROGRAMMED FOR 30 MINUTES.
- THE LIGHT FIXTURES ON THIS CIRCUIT ARE TO BE CONTROLLED BY THE OCCUPANCY SENSORS(S) SHOWN IN THE SAME AREA. THE WALL SWITCHES ARE TO SERVE AS MANUAL OFF OVER-RIDES.
- THE LIGHT FIXTURES ON THIS CIRCUIT ARE TO BE CONTROLLED BY AN INTERMATIC RETROFITTER TIMER WITH PHOTOCELL OVER-RIDE (PROGRAMMED PER THE OWNER). UNSWITCHED CONDUCTORS ARE TO BE RUN TO THE RELAY AS REQUIRED TO PROVIDE EMERGENCY FUNCTIONALITY UPON POWER LOSS.

POWER NEW WORK PLAN GENERAL NOTES:

- THE ELECTRICAL CONTRACTOR IS TO PROVIDE INTERLOCKING CONNECTIONS FOR ALL HVAC EQUIPMENT AS REQUIRED. REFER TO THE MECHANICAL SCHEDULES FOR EXACT INTERLOCKING INFORMATION. THE ELECTRICAL CONTRACTOR IS TO COORDINATE THE EXACT LOCATION OF ALL HVAC EQUIPMENT, ETC. PRIOR TO INSTALLATION.
- THE ELECTRICAL CONTRACTOR IS TO COORDINATE THE EXACT LOCATION OF ALL MECHANICAL AND PLUMBING SITE SWITCHES PRIOR TO INSTALLATION.
- ALL DISCONNECTS FOR MECHANICAL UNITS ARE TO BE MOUNTED SECURELY TO THE FLOOR/STRUCTURE. THE ELECTRICAL CONTRACTOR IS TO PROVIDE AND INSTALL UNSTRUT AND MOUNTING HARDWARE AS REQUIRED TO MOUNT THE DISCONNECTS.
- THE ELECTRICAL CONTRACTOR IS TO COORDINATE THE EXACT RECEPTACLE TYPE AND VOLTAGE FOR ALL EQUIPMENT WITH THE RESPECTIVE EQUIPMENT SUPPLIER PRIOR TO INSTALLATION.
- CENTER LIGHTS, OUTLETS, DEVICES ON LENGTHS OF WALLS OR BETWEEN WINDOWS.
- STACK DEVICES, OUTLETS AND SWITCHES WHENEVER POSSIBLE.
- SWITCHES, OUTLETS AND DEVICES SHALL BE CLEAR OF DOOR SWINGS.
- ALL EXPOSED WORK IS TO BE RUN NEATLY IN EMT CONDUIT; PARALLEL AND PERPENDICULAR TO THE COLUMN LINES.
- ALL ELECTRICAL PANELS, LIGHT FIXTURES AND DEVICES ARE TO BE MOUNTED SECURELY TO THE FLOOR/STRUCTURE. THE ELECTRICAL CONTRACTOR IS TO PROVIDE AND INSTALL MOUNTING HARDWARE AS REQUIRED TO MOUNT THE EQUIPMENT.
- ALL EXPOSED WORK IS TO BE RUN NEATLY IN RIGID CONDUIT; PARALLEL AND PERPENDICULAR TO THE COLUMN LINES. OUTLETS AND SWITCHES ARE TO BE SURFACE MOUNTED IN AN INDUSTRIAL BOX WITH RAISED COVERPLATE.
- ALL ALARM, SECURITY AND TELEPHONE WIRING IS TO BE MAINTAINED AND SECURED - ASSOCIATED WORK IS BY OWNER ONLY.

1 PROPOSED FLOOR PLAN
 1/4" = 1'-0"

NO.	REVISION	DATE

kzla
 Kyle Zick Landscape Architecture, Inc.
 36 Bromfield Street Suite 202
 Boston, MA 02108
 617 451-1018 Tel
 www.kyzezick.com

ARCHITECT
bh+a
 Bargmann Hendrie + Archetype, Inc.
 9 Channel Center Street
 Boston, MA 02210
 617 350-0450 Tel

CONSTRUCTION DOCUMENTS

Job Number:
 Project: ARLINGTON RES.
 Drawn By: RB Checked By: AP
 Date: NOVEMBER 10, 2020
 Scale:
 Drawing Title:

Bathhouse
 Electrical Plan
 Sheet Name
 Demo & New Work

SECTION 16100 – ELECTRICAL

PART 1 – GENERAL

1.1 RELATED DOCUMENTS

A. The General and/or Special Conditions Sections are a part of this specification and the Contractor shall comply with them in detail for instructions pertaining to this work. Section 16 is sub-divided for convenience only.

1.2 SCOPE

A. Furnishing of all labor, material, equipment, supplies, and services necessary to construct and install the complete electrical systems as shown on the drawings and specified herein. Work shall include but is not necessarily limited to the following items:

- 1. Service
- 2. Grounding
- 3. Lighting
- 4. Interior Distribution/Branch Circuits
- 5. Outdoor Lighting

1.3 JOB CONDITIONS

A. Site Inspections: Before submitting proposals, each bidder shall visit the site and fully familiarize himself with all job conditions and shall be fully informed as to the extent of his work. No consideration will be given after bid opening date for alleged misunderstanding as to the requirements of work involved in connecting to the utilities, as to requirements of materials to be furnished, or as to the extent of demolition required.

B. Existing Conditions: All utilities, existing systems, and conditions shown on the plans as existing are approximate, and the Contractor shall verify all details of the project before any work is started.

C. Scheduled Interruptions: Planned interruptions of utilities service, to any facility affected by this contract, shall be carefully coordinated and approved by the Architect at least ten (10) days in advance of the requested interruption. The Contractor shall not interrupt services until specific approval has been granted by the Architect. The request shall indicate services to be affected, date and time of interruption and duration of outage. Request for interruption of service will not be approved until all equipment and material required for the completion of that particular phase of work are on the job site. The work may have to be scheduled after normal working hours.

D. Maintaining Service: Any existing service (or operating system) which must be interrupted for any length of time shall be supplied with a temporary service as necessary for continuation of the normal operation of this facility.

1.4 TEMPORARY POWER

A. Furnish and maintain temporary wiring system for light and power for use during construction by all trades. Use solidly grounded system. Limit over-current protection to 20 amperes on No. 12 conductors. Coordinate all requirements for temporary power with the serving utility and pay for all charges incurred while furnishing power for construction. Verify whether charges for electrical power consumption are specified in Division One; if so, payment of bills for power consumption are not included under this section.

B. Accidental Interruptions: All excavation and/or remodeling work required shall be performed with care so as not to interrupt other existing services (water, gas, electrical, sewer, sprinklers, etc.). If accidental utility interruption resulting from work performed by the Contractor occurs, service shall be immediately restored to its original condition without delay, by and at the expense of the Contractor, using skilled workmen of the trade required.

1.5 CODES, PERMITS AND INSPECTIONS

A. The installation shall comply with all local, state, and federal laws and ordinances applicable to electrical installation and with the regulations of the latest published edition of the National Electrical Code (N.E.C.) where such regulations do not conflict with those laws and ordinances. The Contractor shall obtain and pay for all permits and inspection fees, and after completion of the work, shall furnish the Architect a certificate of final inspection and approval from the applicable local inspection authorities. Any charges by a utility (Power, Telephone, Cable TV, etc.) for providing service as shown shall be included in the bid and paid by the Contractor.

1.6 DRAWINGS AND SPECIFICATIONS

A. The drawings and these specifications are complementary each to the other. What is called for by one shall be as binding as if called for by both. Where the drawings and/or specifications differ as to quantity or quality, the greater quantity or higher quality shall be provided. Omissions from the drawings and specifications of details of work which are evidently necessary to carry out the intent of the drawings and specifications, or which are customarily performed, shall not relieve the Contractor from performing such work. In any case of discrepancy in the figures or catalog numbers, the matter shall be submitted to the Architect, who shall promptly make a determination in writing. Any adjustment by the Contractor shall be at the Contractor's own risk and expense. Electrical drawings are diagrammatic only. Do not scale these drawings. All equipment shall be installed in accordance with manufacturer's recommendations and any conflicting data shall be verified before bidding.

1.7 STANDARDS OF MATERIALS AND WORKMANSHIP

A. Materials: All materials shall be new and shall be listed and approved by the Underwriters' Laboratories, Inc., in every case where a standard has been established for a particular type of material in question. All work shall be executed in a workmanlike manner and shall present a neat appearance.

B. Prior Approvals: Equipment and materials of the same type or classification and used for the same purpose, shall be products of the same manufacturer. It is the intention of these specifications to indicate a standard of performance and quality for all materials incorporated in this work. Manufacturer's names and catalog numbers are used to designate the item of equipment or material as a means of establishing grade and quality. Where several manufacturers are named, only those named manufacturers' products will be considered and the Contractor's bid shall be on their products. The first named of several manufacturers is the manufacturer whose product was used in engineering the project. Other named manufacturers, although acceptable as manufacturers, shall guarantee that their equipment will perform as specified and will meet space requirements. Where performance characteristics of such equipment differs from the equipment scheduled on the drawings, the engineer shall reserve the right to reject it. Where use of such equipment requires different quantity or arrangement of foundations, supports, piping, wiring, conduit and any other equipment. The Contractor shall furnish solid changes and additions and pay all costs for all changes to the work and the work of others affected by using such equipment.

C. For approval of products other than those specified, bidders shall submit to the Architect, a request in writing, at least ten (10) days prior to bid date. Requests received after this time will not be reviewed or considered regardless of cause. Requests shall clearly define and describe the product for which approval is requested. Requests shall be accompanied by manufacturer's literature, specifications, drawings, cuts, performance data, model numbers, list of references or other information necessary to completely describe the item. Approval will be in the form of an Addendum to the Contract's specifications issued to all prospective Prime Contract Bidders on record. The Addendum will indicate the additional products which are approved for this project.

D. If a bidder proposes to use substitute materials or equipment for the following items, he shall obtain a minimum of ten (10) days before Bid "Prior Approval" or longer as described in "Instructions to Bidders" for the items indicated below:

- 1. Wire (600 volts and below).
- 2. Primary cable.
- 3. Conduit.
- 4. Outlet cover-plates.
- 5. Wiring devices.
- 6. Wiring.
- 7. Panelboards.
- 8. Safety switches.
- 9. Lighting fixtures.
- 10. Emergency battery units.

E. Approval on other items shall be handled in the normal manner, as described in "Instructions to Bidders", under the heading "Approval of Materials", preferably before receipt of bids.

F. Substitutions: Reference to a particular product by manufacturer, trade name, or catalog number establishes the quality standards of material and equipment required for this installation and is not intended to exclude products equal in quality and similar design. The Architect reserves the sole right to decide the equality of materials proposed for use in lieu of those specified. It shall be the Contractor's responsibility to furnish the information and data sufficient to establish the quality and utility of the items in question, including furnishing samples if required.

G. Shop Drawings: The Contractor shall submit a list of items proposed for use. He shall also submit catalog data and shop drawings on proposed systems and their components, panelboards, safety switches, starters and contactors, transformers, lighting fixtures, and wiring devices. Where substitutions alter the design or space requirements, the Contractor shall defray all items of cost for the revised design and construction including costs to all allied trades involved. Data shall be submitted within ten (10) calendar days after the contract is awarded. Provide six (6) copies of shop drawings unless a greater number of copies is required by the General Conditions. Each submittal data section shall be covered with an index sheet listing Contractor, Sub-Contractor, Project Name, and an index to the enclosed submittals.

H. Each major section of submittals such as power, equipment, lighting equipment, fire alarm, etc., shall be secured in a booklet or stapled with a covering index which lists the following information:

- 1. General contractor with phone number and project manager.
- 2. Subcontractor with phone number and project manager.
- 3. Supplier of equipment with phone number and person responsible for this project.
- 4. Index of each item covered in submittal and model number as proposed in the attached.
- 5. Any deviation from contract documents shall be specifically noted on submittal cover index and boldly on specific submittal sheet.

1.8 TYPE OF PERMANENT ELECTRICAL SERVICE

A. Electrical service shall be 208 volts, 3 -phase, 4 -wire served from a utility service by an underground secondary service. Contractor shall verify all details of electrical service with the serving utility company prior to bid. Contractor shall include any and all costs associated with the service in his bid price and shall pay these costs to the serving utility company. (SERVICE IS EXISTING- AS NOTED)

B. Operating and Maintenance Manuals: At the completion of the work, furnish three (3) copies of written operation instructions which shall include manufacturer's descriptive bulletins, operating and maintenance manuals and parts lists of all equipment installed. Also include in such instructions, the specified size and capacity ratings of all equipment installed. Each set of instructions shall be assembled into a suitable loose-leaf type binder and presented to the Architect for delivery to the Owner.

C. Record Drawings: Maintain one extra set of black-line, white print drawings for use as Record drawings. Records shall be kept daily, using colored pencil. As the work is completed, relevant information shall be transferred to a reproducible set, and copies made to be given to the Architect.

D. Comply with the following for all work specified in Division Sixteen. As-built information shall be shown in scale, using standard symbols listed in the legend. As a minimum, show the following:

- 1. Location of stub-outs, dimensioned from permanent building lines.
- 2. Location and depth of under-slab and in-slab raceways.
- 3. All routing of raceways.
- 4. Corrected panelboard and equipment schedules.
- 5. Corrected circuit numbers as they appear on panelboard directories.
- 6. Corrected motor horsepower and full load amperages.
- 7. Number, size, type of insulation, and number of wires in each conduit or multi-conductor cable whether in conduit or exposed.
- 8. Location of junction boxes and splices.
- 9. Location of access panels.

1.9 INTERFACE WITH OTHER CONTRACTS

A. It shall be the responsibility of the Contractor to cooperate with all other crafts working on this project. All cutting, trenching, backfill, and structural removals to permit entry of the electrical system components shall be done by this Contractor. All patching and finishing shall be done by the General Contractor.

B. It shall be the responsibility of the Electrical Contractor to coordinate, provide, and install the overcurrent protection devices, wire, and conduit as required for the specific equipment installed.

1.10 EQUIPMENT FURNISHED UNDER OTHER SECTIONS

A. This Contractor shall furnish and install complete electrical roughing-in and connection to all equipment furnished under other sections as indicated on drawings. All such equipment shall be set in place as work of other sections.

1.11 EQUIPMENT CONNECTIONS

A. In general, provide electrical power and control systems connections to equipment shown on drawings. Included are wiring raceways, disconnects, starters, and other devices shown. Excluded are devices furnished integrally with the manufacturer's package and work specified in other sections of these specifications.

1.12 GROUNDING

A. Provide grounding and bonding systems in strict accordance with the latest published edition of N.E.C., except where more stringent requirements are specified herein. Inter-connection of neutral and ground is not permitted except at service entrance equipment or as required for a separately derived system. Install grounding conductors to permit shortest and most direct path to ground. Inaccessible joints are not to be made in grounding conductors. Where grounding conductors are in raceway, bond conductor and raceway at both ends. Grounding and bonding fittings used shall be UL listed and be compatible with metals used in system. Sheet metal type straps are not acceptable.

B. Service entrance ground shall consist of driven electrodes, ground ring, building steel, water pipe electrodes, concrete encased electrode, rod and pipe electrodes, or plate electrodes as available. The driven electrodes, building steel, water pipe electrodes, and concrete encased electrodes are the minimum requirements. Unless otherwise shown on drawings, each driven electrode shall consist of one 3/4 inch diameter 10 ft. long copperweld steel rod. Rod made of wrought iron may be used in lieu of copperweld at option of contractor. Water pipe connection shall be made to a minimum one inch diameter metallic cold water pipe. Extend grounding conductor to main telephone equipment space. Interconnect conductors entering and leaving service entrance equipment using grounding bushing and copper conductor.

C. A green insulated ground conductor shall be run in all branch circuit and feeder conduit with phase and/or neutral conductors. Ground conductor shall be sized per NEC or as noted on drawings. Minimum size #12 AWG. Conduit box to device strap or yoke screw connection is not sufficient. Provide an insulated grounding jumper for receptacle circuits.

D. The Electrical Contractor shall test and provide written certification of final ground system; including test method, equipment model and serial numbers, and final measurements at each point. The ground electrode system must be less than 25 ohms.

1.13 GUARANTEE AND SERVICE

A. Upon completion of all tests and acceptance, the Contractor shall furnish the Owner of a written guarantee covering the electrical work done for a period of one (1) year from date of acceptance. Guarantee includes equipment capacity and performance ratings specified without excessive noise levels. Upon notice from the Architect or the Owner, the Contractor shall, during the guarantee period, rectify and replace any defective material or workmanship and repair any damage caused thereby without additional cost.

PART 2 – PRODUCTS

2.1 GENERAL

A. All equipment and materials shall have ratings established by the recognized independent agency or laboratory. The Contractor shall apply the items used on the project within the ratings and subject to any stipulations or exceptions established by the independent agency or laboratory. Use of equipment or materials in applications beyond that certified by the agency or beyond that recommended by the manufacturer shall be cause for removal and replacement of such misapplied items.

2.2 PANELBOARDS

A. General: Furnish and install circuit breaker lighting and appliance panelboards where shown on the drawings and as indicated in the panelboards schedule. Panelboards shall comply with the following industry standard:

1. NEMA Standard PB-1

2. UL Standards: Cabinets and Boxes –UL50; Panelboards – UL 67

3. National Electric Code

B. Panelboards shall be labeled as suitable for use as service equipment in accordance with Article 408 of the National Electrical Code.

C. Box: The panel box shall not be less than 20 inches wide and fabricated from galvanized or galvanealed steel. Box shall have adjustment screws to provide easy alignment for flush mounted applications. Removable end walls to be blank with no KO's. Panelboard box is to have separate UL label and minimum wire bending and gutter requirements to meet the NEC and UL standards. Wiring gutters shall be completely free of any part of trim clamp to prevent damaging wire insulation.

D. Interior Type S3: All interiors shall be completely factory assembled. The design of the interior should permit replacement of circuit breakers without disturbing adjacent units and without machine drilling or topping. Bus bars and breaker branch bus shall be of 98% conductivity copper. Bus sequence shall start at the top left phase bus of the interior for both top and bottom fed panels. Panelboard bus structure and main breaker or main lugs shall have current ratings as shown on the plans or as indicated in panel schedule. Such ratings shall be established by heat rise test in accordance with Standard UL 67. Bus bars shall be supported by glass filled polyester type insulators. All bolts used to connect carrying parts together shall be case hardened, thread-forming type and be accessible for tightening from the front of the panel. Provide an individual circuit number button with an embossed number next to each breaker or provision. Stick on numbers are unacceptable.

E. Dead front to be provided with flange for easy attachment of trim. Incoming cable lugs shall be grouped at one end to separate them from the load side cables. Neutral bussing shall have a lug for each outgoing branch requiring a neutral connection. For easy wiring and shortest cable run possible, load side neutral connection lugs to be split with each side taking 50% of load neutral connections. The interior shall be provided with wing nuts for securing to box without tools.

F. All computer isolation panels shall have 200% neutral bus.

G. Fas-Loch Trim: The panel trim shall be surface or flush as indicated on the drawings. It shall be fabricated from cold rolled steel, painted with an ANSI-61 light gray finish and equipped with concealed hinges, flush lock and a holder for circuit directory card. Trim shall have two separate supports designed to engage the box flange to stabilize and secure the trim during installation. Trim screws to be located behind the lockable door for tamper resistance. No external screws on trims will be allowed. Trims shall be hinged to box.

H. Description: The panelboards shall be Sentron type for use on systems as indicated on each panelboard schedule. The panelboard enclosures shall be NEMA Type 1 construction for top or bottom cable entrance and suitable for surface or flush mounting unless otherwise noted on panelboard schedules. Panels shall be interchanged from top or bottom feeds.

I. Short circuit rating shall be as indicated on panel schedule.

J. Provide main lug only or main circuit breaker panel boards as shown on a panelboard schedule and equipped with concealed hinges, breakers of the quantity, trip rating and number of poles as shown on schedules. All panels shall accept additional feed thru lugs or subfeed breaker without modification to bus.

K. Molded case circuit breakers shall be thermal magnetic, quick make, quick break, trip free. Multi-pole breakers shall be common trip. All breakers shall be equipped with quick disconnects, pressure type connectors. All provisions shall be located at the bottom of the panelboard and be fully bussed complete with all necessary mounting hardware less the breaker. No plug in breakers will be allowed.

L. All panels shall be fully rated. No series rating of breakers is acceptable.

M. Provide subfeed lugs, feed through lugs, handle blocking devices, pad locking devices, shunt trips and ground bus bars as shown on schedules.

N. Panelboards shall be manufactured by Siemens, General Electric or Square D or prior approved.

2.3 NAMEPLATES

A. Each new panel shall have an external mica-type engraved nameplate. Disconnect switches, starters or similar devices shall have a mica-type engraved nameplate mechanically affixed (no glue) indicating the load served and the location, such as "A/C 2" or "A/C 3 above ceiling". Letters shall be 1/4" block on a white background. Panels shall be designated in this manner:

*Panel A

120/208 Volts
3 Phase, 4 Wire

2.4 DIRECTORIES

A. For panelboards, install typewritten directories, listing each branch circuit, identifying space and equipment it controls. Label panels, disconnect switches, pushbuttons, motor starters, and time clocks with identification shown on plans using engraved nameplates, identify main and switches ahead of mains, noting equipment they serve.

2.7 RACEWAY AND FITTINGS

A. Conduit Systems: Acceptable types of conduit:

- 1. Hot dipped galvanized rigid steel (GRS)
- 2. Electrical Metallic Tubing (EMT)
- 3. Polyvinyl Chloride – Schedule 40 (PVC 40)
- 4. Flexible Metallic Conduit (1/2" min. trade size) (FLEX)
- 5. Liquid Tight Flexible Metallic Conduit (1/2" min. trade size) (LQFLEX)

B. Conduits installed in earth fill, in concrete, or in solid masonry structures shall be PVC 40. Where PVC 40 is used, the 90 degree elbows rising above grade or extending through the concrete envelope shall be GRS. Conduits installed in moist and/or damp locations shall be PVC 40. Conduits subject to mechanical injury shall be GRS.

C. Conduits used for connection to recessed lighting fixtures shall be FLEX. Conduits for connection to motors or vibrating equipment shall be LQFLEX not less than 18" long and not over 60" long. All flexible conduits are to be secured at a minimum of every three feet using approved methods.

D. Conduits run concealed in the hollow space of non-masonry wall or above suspended ceilings shall be EMT. Exposed conduits shall be run at right angles to or parallel with building lines and exposed structures. In all cases, conduit runs shall be grouped together where possible and shall be supported from the building structure, not from any suspended ceiling support system.

E. All EMT connectors and couplings are to be steel set screw type. All EMT connectors are to be insulated bushing type.

F. All conduit bends are to be made with a device made for the application. All conduit runs are to be parallel or perpendicular to the building structure. Conduit offsets are to be utilized at junction boxes and device boxes and a strap placed on conduit at the point nearest the box for support.

G. Support raceways securely with pipe straps, wall brackets, conduit hangers or ceiling trapeze. Fastenings shall be by wood screws or screw type nails to wood; by toggle bolts to concrete block, expansion bolts on concrete or brick, and beam clamp types on steel or bar joists. Raceways shall not be fastened to suspended ceiling supports but must have independent support from the structure. Supporting devices shall be of materials having tensile strength not less than equal to the raceway. A support shall be provided as close as practical to, and not exceeding 18" from an unsupported box or from change of direction. In horizontal runs, this support may be omitted if the box is independently supported and the box connection is not made with chose nipple or threadless box connector. In vertical runs, load produced by weight of the raceway and conductors shall not be carried by the raceway terminal, but must be carried entirely by conduit supports. Install conduit supports in strict accordance with the following table, except as required by support for boxes and changes in direction:

MAXIMUM SUPPORT TRADE SIZE	LOCATION OF RUNS	SPACING
1/2, 3/4	Exposed, Horizontal	7 feet
1 and larger	Exposed, Horizontal	10 feet
All sizes	Concealed, Horizontal	10 feet
1/2, 3/4	Exposed, Vertical	7 feet
1, 1-1/4	Exposed, Vertical	8 feet
1-1/2 and larger	Exposed, Vertical	10 feet
All sizes	Concealed, Vertical	10 feet

H. For conduit runs that are not sized on drawings, the maximum conduit fill shall be computed using the requirements for Type THW conductors although the actual wiring is with Type THWN or other type of conductors having smaller cross-sections. This requirement is made to provide spare conduit capacity.

I. Install all required sleeves for conduits passing through concrete slabs. Fire proof space between conduit and sleeve after installation using of mineral wool as required. All fire wall penetrations are to be sealed with a U. L. approved method. Any penetrations of the roof membrane must be sealed by a certified roofing contractor using an approved method.

J. Conductors: All conductors shall be installed in conduit. Conductors for building wiring shall have THHN/THWN, 600 volt insulation and shall be soft-drawn copper of standard American Wire Gauge (AWG) size. Minimum size shall be No. 12. All wire No. 8 and larger shall be stranded. All branch circuits No. 10 and smaller shall be wired with color-coded wire with the same color used for a system throughout the building. Power feeders and branch circuits larger than No. 10 shall either be fully color coded or shall have black insulation and be similarly color coded with tape or paint in all junction boxes and panels. Where tape or paint is used to identify conductors, apply at all terminations, junction boxes, pull boxes and wireways. Apply tape, but topped, or paint for a minimum distance of 2" and, where applied to ends of conductors, start at cut end of the conductor insulation. Tape shall not cover manufacturers' conductors shall be color coded or labeled as necessary for clear identification. Color coding of all conductors shall be per 208 volt requirements.

K. All circuits are to be run with a neutral conductor. No shared neutral conductors are allowed.

2.8 JUNCTION AND PULL BOXES

A. Junction and pull boxes shall meet requirements of National Electrical Code. Standard manufactured boxes shall be listed by Underwriters' Laboratories, Inc. Where custom designed and fabricated boxes are needed, they shall meet the construction standards of Underwriters' Laboratories, Inc. and the N.E.C.

B. Junction and pull boxes shall be installed where required by National Electrical Code and where necessary to facilitate pulling of wire or cable. Considerations are sizes of wire and cable, number of bends in raceway, and conductor support requirements in vertical raceways. Maximum distance between terminations at junction or pull boxes, cabinets, or other points of termination shall not exceed 250 feet for straight horizontal runs. This length shall be decreased 50 feet for each 90 degree bend. All junction boxes shall be independently and rigidly supported from the building structure.

2.9 OUTLETS

A. Outlet boxes shall be one piece or projection welded, galvanized stamped steel for gang sizes required. Where several devices are located on drawings in the same general location, use multi-gang boxes. Sectional boxes or receptacle boxes are not acceptable. Boxes shall be sized in accordance with National Electrical Code. Boxes required for control devices, etc., shall be installed under this section of the specifications. Verify outlet box locations and sizes required for systems other than electrical power from shop and manufacturer's drawings, and install outlets as per those requirements.

B. Boxes for wall and ceiling outlets shall finish flush and straight. Wall outlets in exposed concrete block, masonry, and tile walls shall be installed with extra deep square corner boxes or with standard boxes and square corners. The wall covers so that conduit offsets are not required. Openings in concrete blocks or masonry walls shall be saw cut with an opening tolerance of 1/8" on all sides, the opening shall have bottom of box at nearest masonry joint to dimension indicated. For other wall finishes, boxes shall be installed with plaster or device type covers as required. No outlets shall be installed back-to-back. Where outlets occur in stud walls back to back on opposite sides, they shall be isolated by a solid stud between them or shall have a 24" separation. For boxes installed in a fire rated barrier, a U.L. approved putty pad shall be installed as required.

2.10 WIRING DEVICES

A. Colors: Wiring device and plate colors shall be selected by Architect for individual wiring runs. The racepieces are to be rigidly secured independent of device plate and such that the device plate secures to the device as the design specifies.

B. Receptacles: Duplex receptacles shall be specification grade, 20 amps, 125 volts with a standard ground. The racepieces are to be rigidly secured independent of device plate and such that the device plate secures to the device as the design specifies.

C. Switches: Standard flush tumbler switches shall be specification grade, 20 amps, 120/277 volts A-C only, single pole, three-way or four-way as shown, single throw with screw terminals arranged for side wiring. The switches are to be rigidly secured independent of device plate and such that the device plate secures to the device as the design specifies.

D. Device Plates: Shall be of the specification grade high impact stainless steel. The nominal thickness is to be .0702". Color to match device.

E. Ground Fault Receptacles: Furnish and install receptacles with ground fault circuit interrupters as indicated on plans. Receptacles shall be NEMA 5-20R configuration with 120V ac 20 amperes circuit rating. All receptacles shall be such depth as to permit mounting in outlet boxes 1-1/2" or greater in depth without the use of spacers. Units shall have line and load terminals such that connection to load terminals will provide ground fault protection for all receptacles. All receptacles shall accept standard duplex wall plates. All receptacles shall be noise suppressed and shall be UL listed. Any device located within 767" of a source of water is to be GFCI protected.

F. All devices are to be installed such that devices do not move when in normal use. The device plate shall not be used to secure device in place.

2.11 LIGHTING FIXTURES

A. Provide wired, cleaned, and with lamps specified, all fixtures designated on drawings. Contractor shall verify the ceiling construction for correct trim and support arrangement of lighting fixtures; corrosion resistant plaster frames are required in plaster ceilings. Shop drawings and submittals shall consist of properly identified copies of manufacturer's catalog pages showing all features and accessories specified.

B. Secure mounting and support of all lighting fixtures shall be accomplished under this section of the specifications. Fluorescent fixtures shall be supported by additional wires on all four corners. All fixtures, including exit, emergency, cans etc., are to be independently supported from building structure. Grid clips on fluorescent fixtures are to be engaged. Where necessary, additional ceiling hanger wires shall be provided for fixture support. Flexible connections to fixture shall not exceed 3 feet in length. Fixtures shall be solidly grounded to raceway system.

C. In areas where the reflected ceiling plan is shown, all work shall be in conformance with this plan. If the ceiling grid is installed other than shown on the electrical plan, it shall be the responsibility of the installer of the lighting fixtures to call this fact immediately to the attention of the Architect and Contractor, and work shall not proceed until Architect's decision in the matter is obtained.

D. Fluorescent ballasts shall be electronic, sound rated, high power factor, energy-saving type. Where local ordinances require the fusing of fluorescent lamp ballasts, provide factory installed and sized buss in-line fuses (Type GLR with HLR fuse holder). Use of low power factor ballasts is permissible only when specifically scheduled on drawings.

E. All lamps shall be the product of one manufacturer and shall be as manufactured by General Electric or Sylvania.

2.12 PRODUCT DELIVERY, STORAGE AND HANDLING

A. Protections: Take necessary precautions to protect all material, equipment, apparatus, and work from damage. Failure to do so to the satisfaction of the Architect will be sufficient cause for the rejection of the material, equipment, or work in question. Contractor is responsible for the safety and good condition of the materials installed until final acceptance by the Owner.

B. Cleaning: Conduit openings shall be capped or plugged during installation. Fixtures and equipment shall be tightly covered and protected against dirt, moisture, chemical, and mechanical injury. At the completion of the work, the fixtures, material and equipment shall be thoroughly cleaned and delivered in condition satisfactory to the Architect.

PART 3 – EXECUTION

3.1 EXCAVATION, TRENCHING AND BACKFILLING

A. Trenches for all underground conduits shall be excavated to the required depth. The bottom of trenches shall be tamped hard. Before backfilling the excavation shall be cleaned of trash and debris. Backfill shall consist of excavation or borrow of sand, gravel, or other approved material free of trash, lumber, sawdust or other debris. Backfill shall be placed in 6" thick moistened and hand or machine tamped layers. Backfill shall be brought to suitable elevation above ground to provide for anticipated settlement and shrinkage. All paving broken up shall be repaired and returned to the original condition.

3.2 PAINTING

A. Contractor shall touch-up or refinish all items of electrical equipment furnished with a factory finish coat of paint and which may have been damaged regardless of cause.

3.3 TESTING AND BALANCING

A. Balance all single-phase loads connected to all panelboards to ensure all equipment equal division on these loads on main power supply, serving building. All tests shall be made in accordance with the latest standards of the IEEE and the NEC. The installation shall be tested for performance, grounds and insulation resistance. "Megger" type instruments shall be used. Contractor shall perform circuit continuity and operational tests on all equipment furnished or connected by Contractor. The tests shall be made prior to final inspection. The Contractor shall provide oil testing equipment and all costs shall be borne by him. Written reports shall be made of all tests. These reports shall be turned over to the Architect at time of final inspection. All faults shall be corrected immediately.

3.4 CLEANING UP

A. The Contractor shall remove all oil, grease, or other stains resulting from his work performed in the building or the exterior thereof.

3.5 WARRANTY AND MAINTENANCE

A. The Electrical Systems and associated materials shall be covered by the warranty for a period of one year. All materials, installation, and workmanship shall be warranted during warranty period. That is, any item will be repaired at no charge for any defects for one year after the date of acceptance.

END OF SECTION 16100

ARLINGTON RENOVATIONS TO EXISTING BUILDINGS

ARLINGTON, MASSACHUSETTS

TOWN OF ARLINGTON

NO.	REVISION	DATE
-----	----------	------

kzla
Kyle Zick Landscape Architecture, Inc.
38 Bromfield Street Suite 202
Boston, MA 02108 617 451-1018 Tel
www.kyzick.com

ARCHITECT

bhta
Bargmann Hendrie + Archetype, Inc.
9 Channel Center Street
Boston, MA 02210
617 350-0450 Tel

CONSTRUCTION DOCUMENTS

Job Number:	
Project:	ARLINGTON RES.
Drawn By:	RB
Checked By:	AP
Date:	NOVEMBER 10, 2020
Scale:	
Drawing Title:	

Bathouse

Electrical
Sheet Name
Specifications

E200