

**CONTRACT FOR**  
**FESSENDEN ROAD SEWER CONSTRUCTION PROJECT**  
**TOWN OF ARLINGTON, MASSACHUSETTS**  
**BID # 21-18**

**TOWN OF ARLINGTON**  
**DEPARTMENT OF PUBLIC WORKS**



## TABLE OF CONTENTS

Table of Contents .....	ii
I. Invitation for Bid .....	1
II. Instruction to Bidders .....	2
1. Receipt of Bids .....	2
2. Preparation of Bid.....	2
3. Bid Security.....	2
4. Time of Completion.....	2
5. Performance and Labor Material Bonds .....	2
LABOR & MATERIALS BOND.....	3
6. Laws and Regulations .....	4
7. Withdrawal of Bids .....	4
8. Execution of Contract .....	4
9. Obligation of Bidder .....	4
10. Omissions, Discrepancies, Interpretations and Addenda .....	4
11. Record of Address .....	4
12. Massachusetts Sales and Use Tax .....	4
13. State Tax Affidavit.....	4
14. Minimum Wage Rates .....	5
15. Sub-bids .....	5
16. Supplemental Information .....	5
III. Proposal .....	6
1. Bid Sheet.....	7
2. Locus Map.....	<b>Error! Bookmark not defined.</b>
CERTIFICATION OF TAX COMPLIANCE .....	11
CERTIFICATE OF NON-COLLUSION .....	12
IV. Contract.....	13
1. Definitions .....	13
2. Parts of Contract.....	13
3. Obligations of the Contractor.....	13

4. Liability of the Contractor..... 13

5. Authority of the Engineer ..... 14

6. Engineer to Decide ..... 14

7. Time for Commencing Work ..... 14

8. No Damages for Certain Delays..... 14

9. Time for Completion..... 15

10. Competent Men to be Employed ..... 15

11. Access to Work ..... 15

12. Defective Work, Materials or Equipment..... 15

13. Mistakes of Contractor ..... 16

14. Discrepancies, Errors and Omissions..... 16

15. Right to Materials ..... 16

16. Compliance with Laws, Ordinances, and Regulations ..... 16

17. Provisions Required by Law Deemed Inserted..... 17

18. Work Hours..... 17

19. Intoxicating Liquors ..... 17

20. Permits and Notices..... 17

21. Patents..... 17

22. Insurance ..... 17

23. Work Not to be Sublet or Assigned ..... 18

24. Alterations ..... 18

25. Extra Work..... 18

26. Extension of Time on Account of Extra Work..... 19

27. Changes Not to Affect Bonds..... 19

28. Completion of Work if Contract is Not Fulfilled ..... 19

29. Compensation for Work ..... 20

30. Money may be Retained ..... 21

31. Estimates and Payments ..... 21

32. Partial Payment Not Acceptance..... 21

33. Liens..... 21

34. Waiver ..... 22

35. Liability of the Town of Arlington .....	22
36. Guarantee .....	22
37. Money Retained for Repairs.....	22
38. Address of Contractor .....	23
39. Certificate of Vote .....	24
CERTIFICATE OF VOTE .....	24
V. Performance Bond .....	25
VI. General Conditions .....	26
1. Definitions .....	26
2. Abbreviations.....	26
3. Handling Materials .....	26
4. Storage Room .....	26
5. Shop Drawings, Schedules, and Descriptive Matter.....	27
6. Equivalentents .....	27
7. Materials and Workmanship .....	27
8. Inspection by the Engineer.....	27
9. Documents at Site of Work .....	27
10. Lines and Grades .....	28
11. Scaffolding and Protection .....	28
12. Public Safety and Property of Others .....	28
13. Existing Structures, Pipes, Conduits, Etc .....	28
14. Sanitary Provisions .....	28
15. Cutting and Patching .....	28
16. Debris.....	28
17. Measurement of Quantities .....	28
18. Compliance with Occupational Safety and Health Act of 1970.....	29
19. Order of Precedence Governing Specifications.....	29
20. Affirmative Action/Anti-Discrimination.....	29
21. Compliance with Requirements .....	30
22. Non-Discrimination.....	31
23. Solicitations for Sub-Contracts, and for the Procurement of Materials and Equipment .....	31

24.	Bidders Certification Requirement .....	31
25.	Contractor’s Certification .....	31
26.	Compliance-Information, Reports and Sanctions .....	31
27.	Severability .....	32
VII.	Special PROVISIONS .....	33
1.	Scope of Work .....	33
2.	Contract Requirements & Definitions .....	33
3.	Schedule & Safety Measures for Construction Impacts .....	33
4.	Qualification .....	34
5.	Inspection .....	34
6.	Work by Others and Cooperation by the Contractor .....	34
7.	Public Safety & Convenience .....	34
8.	Cleaning Up.....	35
9.	Provisions for Access at All Locations.....	35
10.	Provisions for Travel & Prosecution of the Work .....	35
11.	Traffic Orders.....	36
12.	Work Coordination & Abutter Notification .....	36
13.	Temporary Access to Area Abutters.....	36
14.	Storage of Materials & Equipment .....	37
15.	Computation of Quantities.....	37
16.	Water Supply .....	37
17.	Sanitary Regulations.....	37
18.	Increased or Decreased Contract Quantities .....	37
19.	Contract Guarantee & Retainage .....	37
20.	Precautions under Electric Lines .....	38
21.	Asphalt Cost Adjustment Clause .....	38
VIII.	Specifications .....	39
1.	Item 1: Unclassified Trench Excavation.....	39
1.1.	Description .....	39
1.2.	Unsuitable Backfill Material .....	39
1.3	Method of Measurement and Payment.....	41

- 2. Item 2: Crushed Stone ..... 40
  - 2.1 Description ..... 40
  - 2.2 Method of Measurement and Payment..... 40
- 3. Item 3: Processed Gravel..... 40
  - 3.1. Description ..... 40
  - 3.2 Material ..... 40
  - 3.3 Method of Measurement and Payment..... 41
- 4. Item 4: Remove Sewer Structure ..... 41
  - 4.1 Description ..... 41
  - 4.2 Method of Measurement and Payment..... 41
- 5. Item 5: Furnish and Install Sewer Manholes (0'-9')..... 41
  - 5.1 Description ..... 41
  - 5.2 Method of Measurement and Payment..... 41
- 6. Item 6: Furnish and Install Frame and Cover ..... 42
  - 6.1 Description ..... 42
  - 6.2 Method of Measurement and Payment..... 42
- 7. Item 7: Furnish and Install 8 Inch Sewer Pipe ..... 42
  - 7.1 Description ..... 42
  - 7.2 Method of Measurement and Payment..... 42
- 8. Item 8: Furnish and Install 6" PVC Drop Inlet..... 42
  - 8.1. Description ..... 40
  - 8.2 Method of Measurement and Basis of Payment ..... 42
- 9. Item 9: Saw Cutting Asphalt ..... 43
  - 9.1 Description ..... 43
  - 9.2. Method of Measurement and Payment..... 43
- 10. Item 10: Hot Mix Asphalt..... 43
  - 10.1 Description..... 43
  - 10.2 Maintenance Period of Roadway Surface ..... 43
  - 10.3 Method of Measurement and Basis Payment ..... 44
- 11. Item 11: Loam Borrow..... 44
  - 11.1 Description..... 44

11.2 Method of Measurement and Basis of Payment ..... 44

12. Item 12: Seeding and Rolling ..... 44

12.1 Description ..... 44

12.2 Method of Measurement and Basis of Payment ..... 44

## **I. INVITATION FOR BID**

Sealed bids are invited and will be received by the Town Manager, Town of Arlington, Massachusetts, until **10:00 AM JUNE 23, 2021** at the Office of the Purchasing Agent, Town Hall, Arlington, Massachusetts 02476, at which time and place they will be publicly opened and read.

A BID DEPOSIT IN THE FORM OF CASH, CERTIFIED CHECK, OR TREASURER'S CHECK, shall accompany every bid. The amount of such bid deposit shall be FIVE PERCENT (5%) of the value of the bid.

Specifications and proposal forms will be available at the Office of the Purchasing Agent, Town Hall, Arlington, Massachusetts. All bids must be in sealed envelopes plainly marked: **BID #21-18: FESSENDEN ROAD SEWER CONSTRUCTION PROJECT.**

The conditions of employment as set forth in Sections 26 to 27D and 27F of Chapter 149 of the General Laws, as amended, shall prevail in the execution of the work under this contract.

Attention is called to the fact that minimum wage rates and health and welfare and pension fund contributions are established for this contract and are a part of the specifications.

Work under this contract shall be governed by M.G.L.Ch.30, Sec. 39M.

Attestation Forms pursuant to M.G.L. Ch. 62C, Sec. 49A and M.G.L. Ch. 701 of the Acts of 1983 are enclosed and shall be submitted with bids.

Proposals are for construction of a sewer line with manholes on Fessenden Road in the Town of Arlington, MA.

**It is the intention of the Owner to award the Contract to the lowest qualified responsive bidder. The bidder must submit a bid on all bid items in the Contract.**

All proposals to include prices in both writing and in figures, and must be signed by the bidder with his business address.

An increase or decrease in the quantity of work shall not be regarded as a sufficient ground for an increase in the unit prices.

To receive consideration, bids must be in the hands of the Purchasing Agent or his authorized representative not later than the day and hour *above* mentioned. For further information relative to this bid, please confer with Domenic R. Lanzillotti, Director, Purchasing Department, Town Hall, Arlington, Massachusetts, 02476.

OSHA Construction Training Required: As of July 1, 2006, under M.G.L. -Chapter 30, Section 39s, any person, submitting a bid for, or signing a contract to work on, the construction, reconstruction, alteration, remodeling or repair of any public work by the Commonwealth of Massachusetts/Town of Arlington, and estimated by the awarding Authority to cost more than \$10,000, shall certify on the Bid or Contract, under penalty of perjury, that all employees to be employed at the work will have successfully completed a course in construction safety and health approved by the United States Occupational Safety and Health Administration that is at least 10 hours in duration

The Town Manager reserves the right to cancel any invitation for bids, to reject in whole or in part any and all bids, when it is deemed in the best interest of the Town of Arlington to do so.

---

Adam W. Chapdelaine

Town Manager

June 9, 2021



## **II. INSTRUCTION TO BIDDERS**

### **1. Receipt of Bids**

The Town may consider informal any bid not prepared and submitted in accordance with the provisions hereof and may waive any informality in or reject any bids. Any bid may be withdrawn before the time for the opening of bids. Any bid received after the time and date specified shall not be considered. No bidder may withdraw his/her bid for a period of 30 days, excluding Saturdays, Sundays, and legal holidays after actual date of the opening thereof.

### **2. Preparation of Bid**

Each bid shall be submitted on the forms attached to these documents. The bid forms may be removed and submitted separately from the other documents. All blank spaces for bid prices must be filled in with the unit price for the item or the lump sum for which the proposal is made. Bidders must bid on each item. All entries in the entire proposal must be made clearly, and prices written in both words and figures in the spaces provided.

Each bid must be in a sealed envelope addressed to the Office of the Purchasing Agent, 730 Massachusetts Avenue, Arlington, Massachusetts, 02476; and bearing on the outside the name of the bidder, his/her address, the name of the project for which the bid is submitted, and the notation **BID #21-18: FESSENDEN ROAD SEWER CONSTRUCTION PROJECT**.

### **3. Bid Security**

Every bid submitted by contractors shall be accompanied by a bid deposit in the form of cash, certified check, treasurer's or cashier's check, or a bid bond issued by a responsible bank or trust company and made payable to the Town of Arlington. The amount of the bid deposit shall be 5% of the amount of the bid. All security except those of the three lowest responsible and eligible bidders will be returned within ten days, Saturdays, Sundays, and legal holidays excluded, after opening of the bid. All bid securities will be returned on the execution of the contract or if no award is made within 30 days, excluding Saturdays, Sundays, and legal holidays, after the actual date of the opening thereof, unless forfeited under the conditions herein stipulated.

In case a party to whom a contract is awarded shall fail or neglect to execute the contract and furnish the satisfactory bond in the time specified, the Town may determine the bidder has abandoned the contract and thereupon the proposal and acceptance shall be null and void, and the bid security accompanying the proposal shall be forfeited to the Town as liquidation damages for such failure or neglect and indemnify the Town for any loss which may be sustained by failure of the bidder to execute the contract and furnish the bonds as aforesaid, provided that, in case of death, disability, or other unforeseen circumstances affecting the bidder, such bid security may be returned to him/her.

After execution of the contract and acceptance of the bonds by the Town, the bid security accompanying the proposal of the successful bidder will be returned.

### **4. Time of Completion**

The bidder must agree to commence work within thirty (30) business days from the date of signing the contract and to fully complete the project within the time specified within the Special Provisions section of this document.

### **5. Performance and Labor Material Bonds**

A bond in the sum of 50% of the total amount of the Contract by the successful bidder and an additional bond in equal amount covering the payment for all labor and materials used in the work will be required. A surety company authorized to do business in Massachusetts and satisfactory to the Town of Arlington must provide these bonds. These bonds will be required at the execution of the contract. Attorneys-in-fact who sign contract bonds must file with each bond a certified and effectively dated copy of their power of attorney.

## **6. Laws and Regulations**

The bidder's attention is directed to the fact that all applicable State laws, Town of Arlington Bylaws, municipal ordinances, and the rules and regulations of all authorities having jurisdiction over construction of the project shall apply to the contract throughout, and they shall be deemed to be included in the contract the same as though herein written out in full.

## **7. Withdrawal of Bids**

Upon proper written request and identification, Bids may be withdrawn only as follows:

1. At any time before the designated time for the opening of Bids.
2. Death or serious injury of a principal.
3. With the written approval of the Town of Arlington Office of the Purchasing Director.
4. At any time after the expiration of the period during which withdrawal is prohibited provided the bid has not been accepted by the Town.

## **8. Execution of Contract**

The party to whom the contract is awarded shall be required to execute the contract and furnish the bonds duly executed with a satisfactory surety company within 10 days, excluding Saturdays, Sundays, and legal holidays, of the date of the mailing of the notice to the bidder according to the address given by him/her, that the contract is ready for execution.

## **9. Obligation of Bidder**

At the time of the opening of bids, each bidder shall be presumed to have read and to be thoroughly familiar with the contract documents. The failure or omission of any bidder to receive or examine any form, instrument, or documents shall in no way relieve any bidder from the obligation in respect to his bid.

## **10. Omissions, Discrepancies, Interpretations and Addenda**

Should a bidder find discrepancies in, or omissions from, the drawings or contract documents, or should he/she have questions as to the interpretation of the plans or contract documents he/she shall submit such in writing to the Director of Purchasing at least five (5) days before the date herein set for the opening of bids. An interpretation will be mailed by certified mail to prospective bidders at the addresses given by them on or about two (2) days before the opening of bids. Signed copies of all addenda shall be included with the bid; omission of the signed addendum shall be cause for rejection of the bid.

## **11. Record of Address**

Prospective bidders shall at the time plans and specifications are secured place on file with the Director of Purchasing their address, and are required to make any changes necessary to insure that the record is accurate, complete, and up to date.

## **12. Massachusetts Sales and Use Tax**

Materials purchased for permanent installation in the work will be exempt from the Massachusetts Sales and Use tax. Each bidder shall consider this exemption in calculating his/her bid for the work.

## **13. State Tax Affidavit**

Prospective bidders are required to certify that all state tax returns have been filed and all state taxes have been paid in order to be eligible to enter into a contract with the Town on this project. The included form is to be used for this purpose and is to be completed and returned as part of the bid and proposal.

#### **14. Minimum Wage Rates**

Prevailing rates for wages for work performed under this Contract will be as predetermined by the Commissioner of Labor and Industries of the Commonwealth of Massachusetts in accordance with the provisions of Sections 26 to 27D, inclusive, of c.149 of M.G.L. A schedule of the prevailing wages is included in the Minimum Wage Rates Section.

#### **15. Sub-bids**

No sub bids shall be sought in connection with this Contract.

#### **16. Supplemental Information**

All bidders shall submit the following supplemental information with a fee proposal:

1. Name, address and phone number of a minimum of three (3) references that can vouch for the performance of the bidder
2. Proof of Liability and Worker's Compensation Insurance Coverage
3. Completed tax attestation form
4. Bid deposit

### **III. PROPOSAL**

For Bid 21-18, Fessenden Road Sewer Construction Project:

To the Town of Arlington, Massachusetts, acting through its Town Manager the undersigned, as bidder, declares as follows:

- 1) The only persons or parties interested in this proposal as principals are named in this proposal;
- 2) This proposal is made without collusion with any other person, firm or corporation;
- 3) He has carefully examined the location of the proposed work and the annexed proposed form of contract, and the drawings and specifications therein referred to;
- 4) This proposal is based solely on his own investigation and research and not in reliance upon any plans, surveys, measurements, dimensions, calculations, estimates, borings, test pits, soundings, or representations of any employee, officer, or agent of the Town;

and the undersigned proposes and agrees that if this proposal is accepted he will contract with the Town, this Proposal form being part of and included in said contract, to provide all necessary machinery, tools, apparatus and other means of construction and to furnish all the labor, supervision, materials, permits and other requisites not expressly stated, necessary to complete the contract in the manner and time therein prescribed and according to the requirements of the plans and specifications; and that he will take in full payment thereof the following sums to with:



**TOWN OF ARLINGTON**  
**DEPARTMENT OF PUBLIC WORKS**  
**ENGINEERING DIVISION**  
 51 GROVE STREET  
 ARLINGTON, MA 02476

Item	Estimate		Description	Proposal	
	Quantity	Unit		Unit Price (\$)	Total Amount (\$)
1	180	CY	Unclassified Trench Excavation	\$ / CY	\$
2	65	CY	Crushed Stone	\$ / CY	\$
3	120	CY	Gravel Borrow	\$ / CY	\$
4	1	EA	Sewer Structure Removed	\$ / EA	\$
5	3	EA	Furnish and Install Sewer Manhole (0'-9')	\$ / EA	\$
6	3	EA	Furnish and Install Frame and Cover	\$ / EA	\$
7	220	LF	Furnish and Install 8 Inch Sewer Pipe	\$ / LF	\$
8	2	VF	Furnish and Install 6 Inch PVC Drop Inlet	\$ / VF	\$
9	450	LF	Saw Cut Asphalt	\$ / LF	\$
10	30	TON	Hot Mix Asphalt	\$ / TON	\$
11	12	SY	Loam Borrow	\$ / SY	\$
12	12	SY	Seeding and Rolling	\$ / SY	\$
<b>Total:</b>					\$

TOTAL BID PRICE IN WORDS : \_\_\_\_\_

FIRM NAME : \_\_\_\_\_

NAME PRINCIPAL: \_\_\_\_\_

ADDRESS: \_\_\_\_\_

AUTHORIZED SIGNATURE: \_\_\_\_\_

DATE: \_\_\_\_\_

CONTACT NAME: \_\_\_\_\_

Email: \_\_\_\_\_



**LOCUS - FESSENDEN STREET**

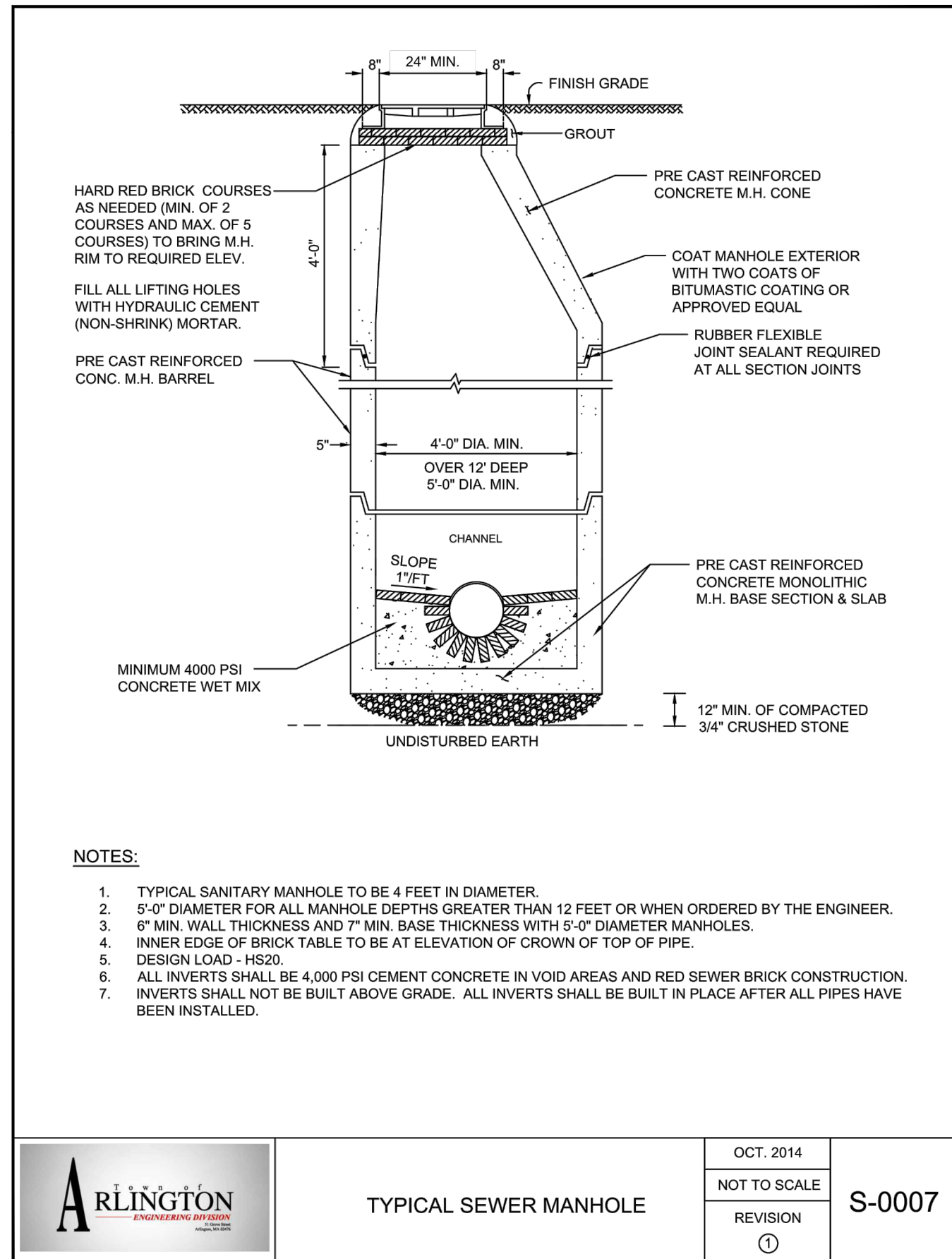
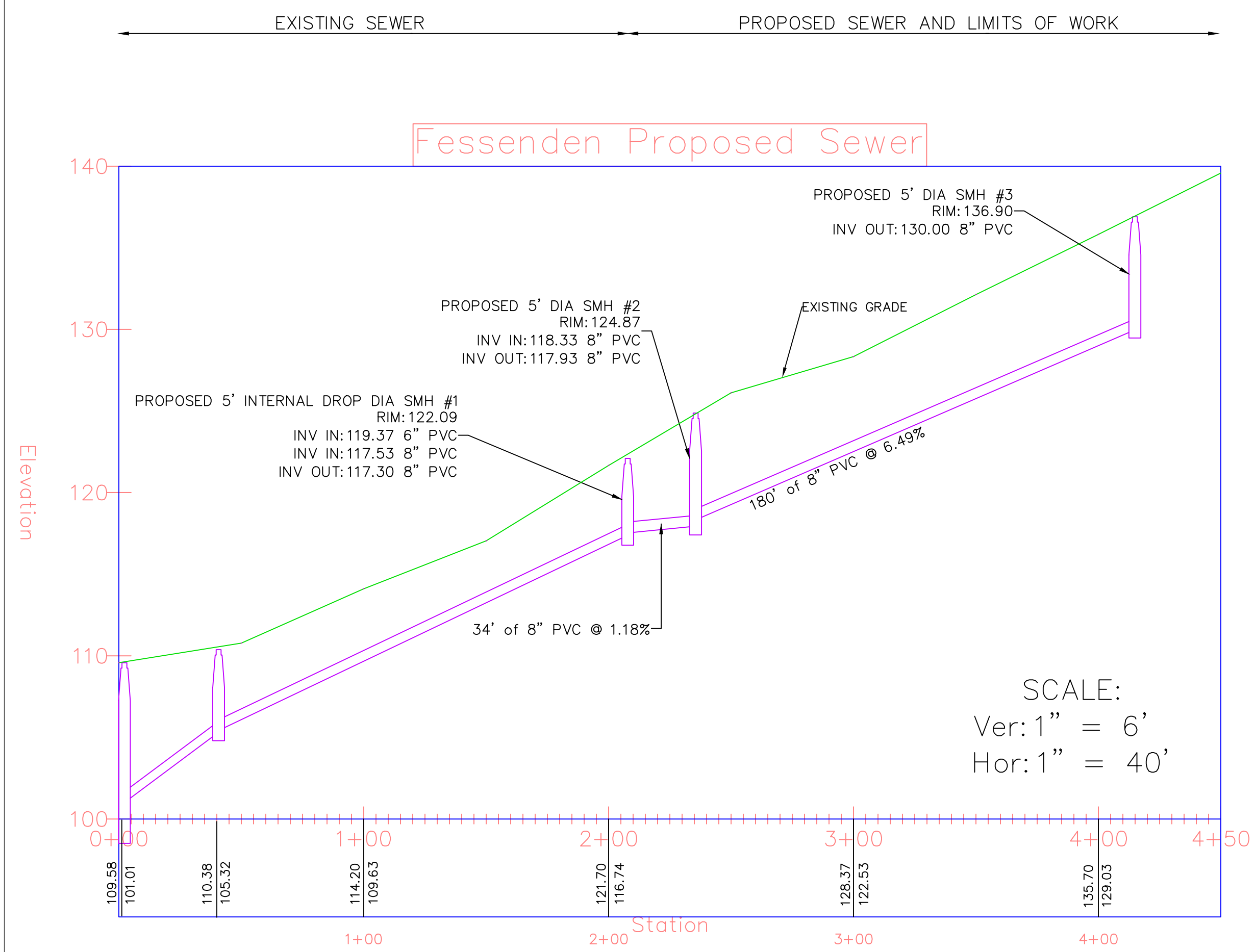
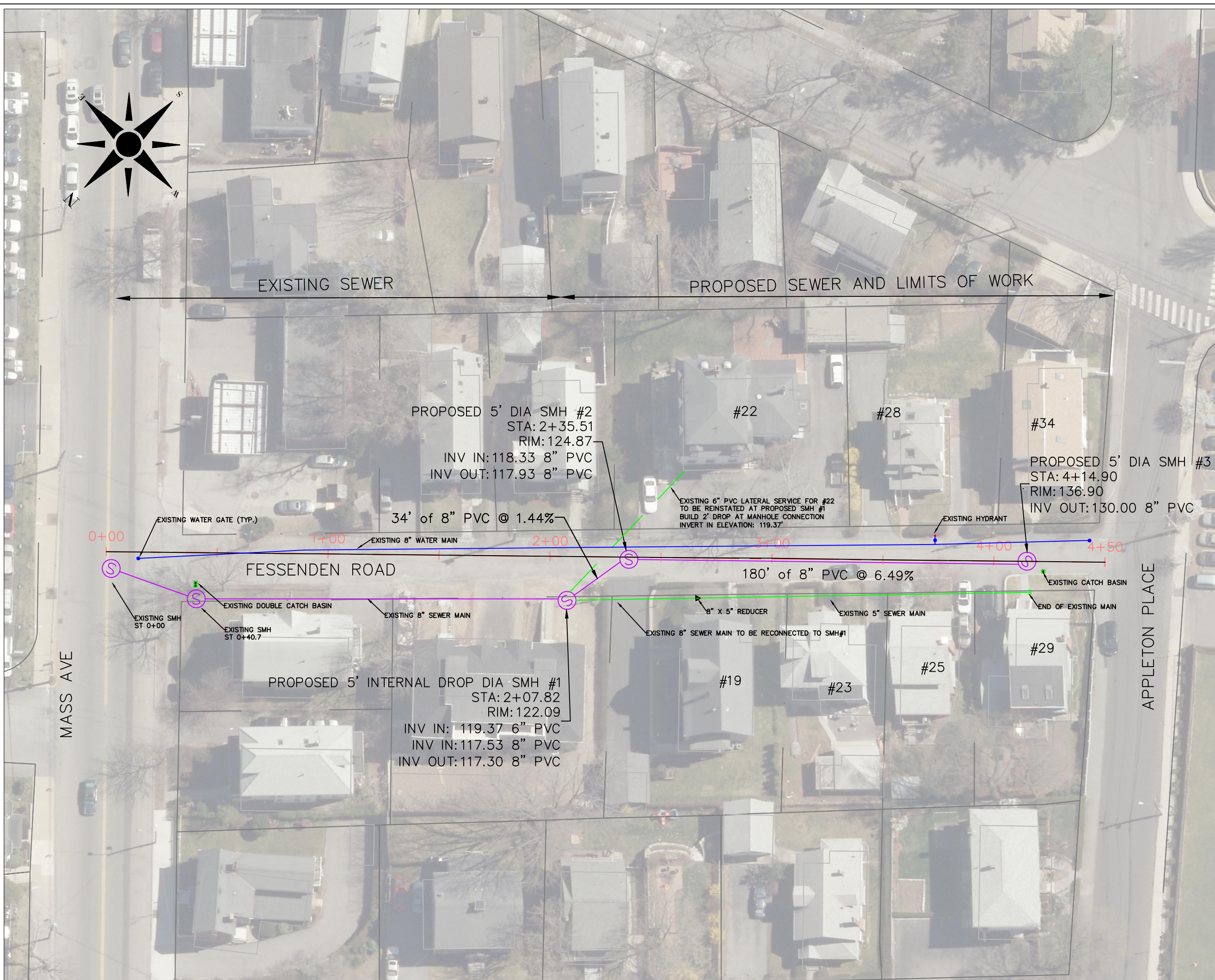

ARLINGTON	TYPICAL SEWER MANHOLE	OCT. 2014	S-0007
		NOT TO SCALE	

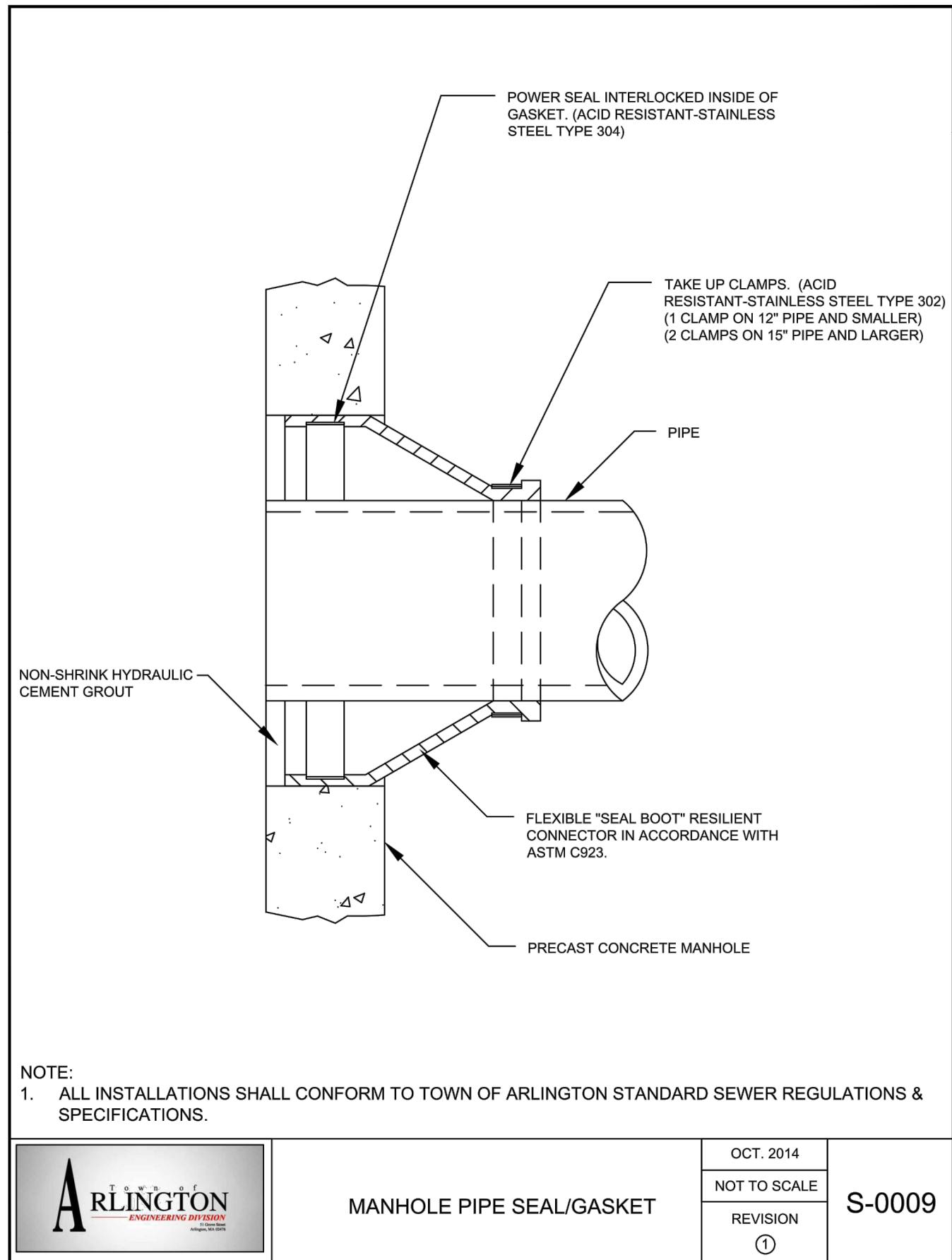

ARLINGTON	MANHOLE PIPE SEAL/GASKET	OCT. 2014	S-0009
		NOT TO SCALE	

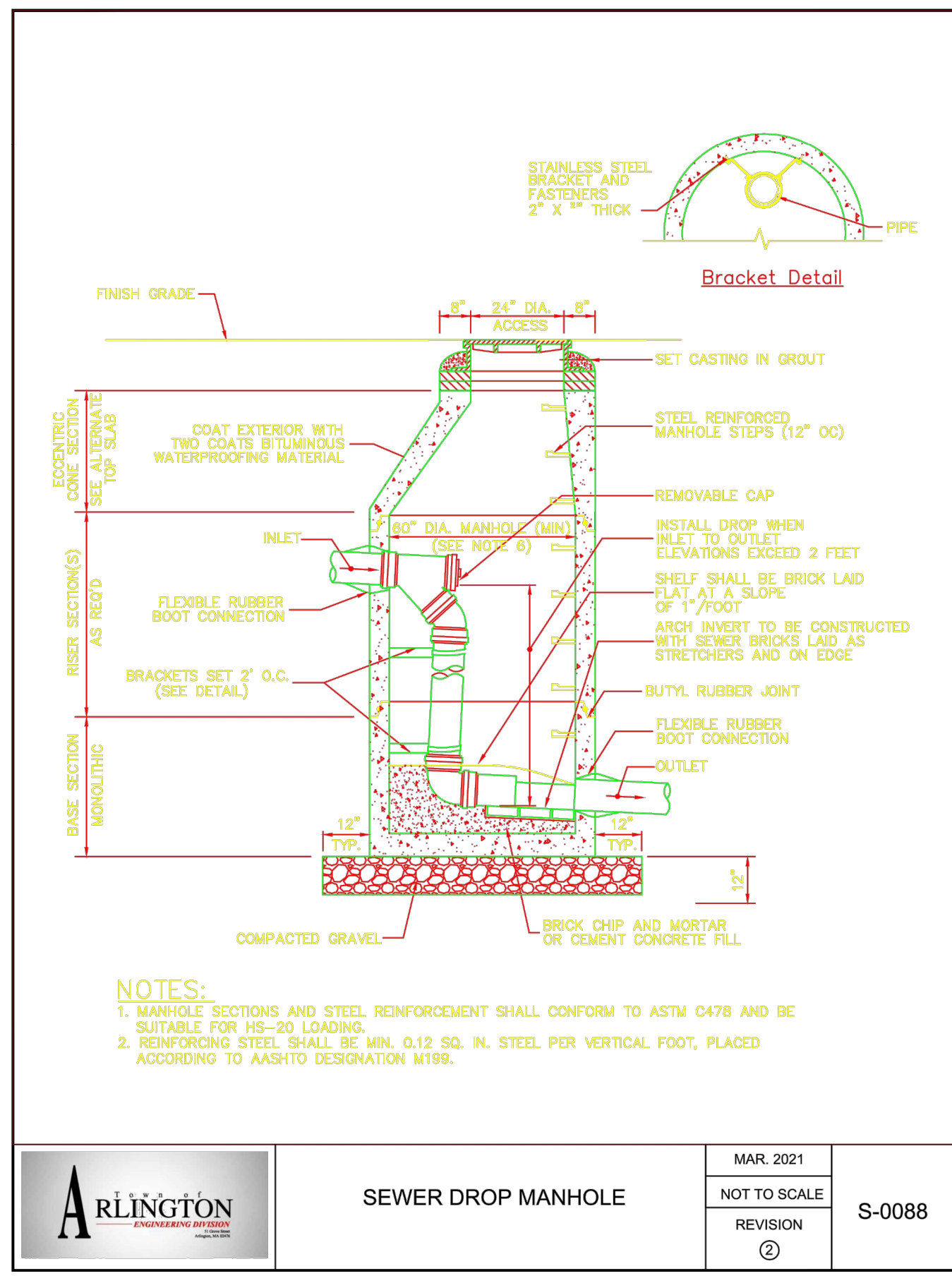

ARLINGTON	SEWER DROP MANHOLE	MAR. 2021	S-0088
		NOT TO SCALE	

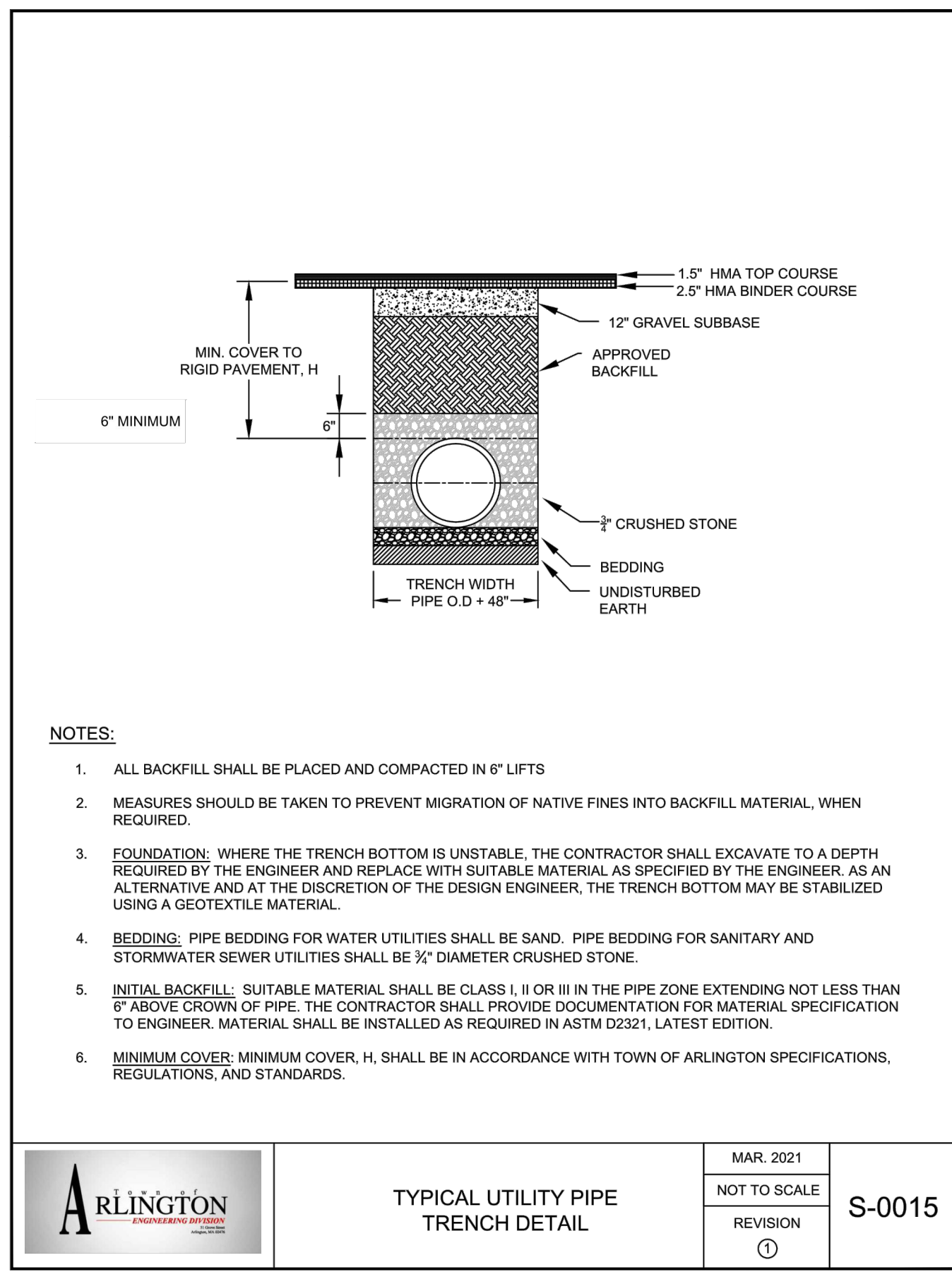

ARLINGTON	TYPICAL UTILITY PIPE TRENCH DETAIL	MAR. 2021	S-0015
		NOT TO SCALE	

- ### NOTES
- PLANS WERE DEVELOPED USING AVAILABLE AERIAL IMAGERY, EXISTING PLANS, AND ON-SITE OBSERVATIONS. A FORMAL SURVEY OF THE PROJECT AREAS WAS NOT CONDUCTED. UTILITY LOCATIONS AND INVERT MEASUREMENTS ARE APPROXIMATE.
  - CONTRACTOR IS RESPONSIBLE FOR NOTIFYING DIG-SAFE AND ALL APPLICABLE UTILITIES OF THE PROPOSED WORK PRIOR TO ANY EXCAVATION. THE TOWN OF ARLINGTON IS NOT A MEMBER OF DIG-SAFE AND MUST BE NOTIFIED DIRECTLY AT LEAST 72 HOURS PRIOR TO EXCAVATION BY CALLING 781-316-3310.
  - CONTRACTOR IS RESPONSIBLE FOR NOTIFYING RESIDENTS AND ABUTTERS OF ANY WORK THAT MAY INTERFERE WITH DRIVEWAY AND WALKWAY ACCESS.
  - EXISTING ASPHALT SHOULD BE SAWCUT PRIOR TO EXCAVATION.
  - CONTRACTOR IS RESPONSIBLE FOR APPROPRIATE CONSTRUCTION SIGNAGE AND BARRIERS AS NEEDED AND SHALL BE CONSIDERED INCIDENTAL TO THE CONTRACT.
  - CONTRACTOR TO MAINTAIN CLEAN WORK ZONE AND SWEEP WORK SITE DAILY.
  - PAVING TO BE COMPLETED WEEKLY.
  - EROSION CONTROL SHALL BE USED WHEN NECESSARY AND CONSIDERED INCIDENTAL TO THE CONTRACT. ANY SEDIMENT THAT ENTERS THE TOWN'S STORM WATER SYSTEM AS A RESULT OF CONSTRUCTION SHALL BE REMOVED AT THE EXPENSE OF THE CONTRACTOR.
  - ANY AREA DISTURBED BY THE CONTRACTOR OUTSIDE OF THE LIMITS OF WORK SHALL BE RESTORED TO ORIGINAL CONDITION AT NO COST TO THE OWNER.
  - ARLINGTON DPW EXCAVATED TEST PITS ALONG THE PROPOSED SEWER LINE AND NO SIGN OF LEDGE WAS PRESENT.
  - CONTRACTOR TO PREVENT ANY SEWAGE FROM ENTERING TRENCH DURING EXCAVATION.

No.	Revision/Issue	Date

Town of  
**ARLINGTON**  
Engineering Division  
51 Grove Street  
Arlington, MA 02476

**FESSENDEN ROAD  
PROPOSED SEWER DESIGN**

Project: #21 - XX	Sheet: 1 OF 1
Drawn By: AC	Scale: 1" = 40'
Date: MARCH 2021	



The above estimated quantities are an approximate statement of the extent of the work to be done; the Town does not expressly or by implication agree that the actual amount of work will correspond therewith but reserves the right to increase or decrease the amount of any class or portion of the work or to delete certain items of work, as may be deemed necessary, to keep within available funds.

The undersigned as bidder, agrees that for extra work, if any, he will accept compensation as stipulated in the annexed form of CONTRACT.

If this proposal shall be accepted by the Town, and the undersigned shall fail to execute the contract for the work and deliver same to the Town, together with the duly executed Performance Bond and Labor and Material Payment Bond, with sureties satisfactory to the Town, within ten (10) days from the date of mailing of a notice from the Town to him at the address herein given that the proposed contract is ready for execution, then the Town at its option may determine that the undersigned has abandoned the said contract and thereupon if it so determines, the bid security accompanying this proposal shall become the property of the Town as liquidated damages; otherwise the accompanying security shall be returned to the undersigned.

All bidders will be required to show that they have previously completed projects of the same type in a satisfactory manner, namely, site excavation and utility installations including sewer mainline and manhole installation.

The bidder awarded this contract will have to show that they have successfully completed at least two (2) contracts of similar work in the \$40,000-100,000 (dollar) range.

In addition, if the successful bidder contemplates using sub-contractors, said sub-contractor will be held to the same standards as noted above.

Before starting work, the contractors (includes the general contractor, for itself and its subcontractors, as well as all filed sub-bid contractors) will submit plans for achievement of the equal opportunity goals of the contract. All contractors will be required to make a good faith effort to achieve these goals. The plan will indicate if the contractors expect to achieve the requirements during the first quarter. If there are any reasons why the contractors do not expect to achieve the requirements during the first quarter year of the contract construction phase, then the contractors shall provide a plan calculated to address, to the extent reasonably possible, these obstacles to a good faith effort to achieve such goals.

Not more than ten days following the end of each work quarter, the contractors will report on the achievement of the goals, the detailing the good faith efforts that have been made and will continue to be made and any other appropriate efforts not yet undertaken.

All reports will be signed by an officer or principal of the company who has the authority to contractually obligate the company.

The contractor shall maintain as a goal on this project a not less than five percent ratio of women work force to total project hours in both the general contract and each individual filed sub-bid contract.

A Labor Scheduling Table which will be used as a tool for achieving a range of women work force participation for the entire project in both the general contract and each individual filed sub-bid contractor.

The bidder is required to furnish a financial statement and give references that will enable the Town to judge his business standing.

**CERTIFICATION OF TAX COMPLIANCE**

Pursuant to MGL c. 62C, § 49A and requirements of the Town of Arlington, the undersigned acting on behalf of the Contractor certifies under the penalties of perjury that the Contractor is in compliance with all laws of the Commonwealth relating to taxes including payment of all local taxes, fees, assessments, betterments and any other local or municipal charges (unless the Contractor has a pending abatement application or has entered into a payment agreement with the entity to which such charges were owed), reporting of employees and contractors, and withholding and remitting child support.\*

\_\_\_\_\_  
\*\*Signature of Individual or Corporate Contractor

\_\_\_\_\_  
Printed Name

\_\_\_\_\_  
\*\*\*Contractor's Social Security Number or  
Federal Identification Number

\_\_\_\_\_  
Date

\* The provision in this Certification relating to child support applies only when the Contractor is an individual.

\*\* Approval of a contract or other agreement will not be granted until the City receives a signed copy of this Certification.

\*\*\* Your social security number may be furnished to the Massachusetts Department of Revenue to determine whether you have met tax filing or tax payment obligations. Providers who fail to correct their non-filing or delinquency will not have a contract or other agreement issued, renewed, or extended.

**CERTIFICATE OF NON-COLLUSION**

The undersigned certifies under penalties of perjury that this bid or proposal has been made and submitted in good faith and submitted in good faith and without collusion or fraud with any other person. As used in this certification, the word “person” shall mean any natural person, business, partnership, corporation, union, committee club, or other organization, entity, or group or individuals.

\_\_\_\_\_  
(Signature of Individual)

\_\_\_\_\_  
(Name of Business/Corporation)

**OSHA TRAINING**

The undersigned hereby certifies that it is able to furnish labor that can work in harmony with all other elements of labor employed or to be employed on the work; that all employees to be employed at the worksite will have successfully completed a course in construction safety and health approved by the United States Occupational Safety and Health Administration that is at least 10 hours in duration at the time the employee begins work and who shall furnish documentation of successful completion of said course with the first certified payroll report for each employee; and that it will comply fully with all laws and regulations applicable to awards made subject to section forty-four A of Chapter 149 of the General Laws.

---

Signature: \_\_\_\_\_

Title: \_\_\_\_\_

Date: \_\_\_\_\_

## **IV. CONTRACT**

### **1. Definitions**

Wherever the word “Town”, “Contractor”, or “Engineer” or pronouns used in place of them occur in this contract, they shall have the following meanings:

1. The word “Town” shall mean the party of the first part above designated, or any board, office, or agent duly authorized to act for said party of the first part in the matter covered by this contract.
2. The word “Contractor” shall mean the party of the second part above designated entering into this contract for the performance of the work required, the legal representative of said party, or the agent appointed to act for said party in performance of the work.
3. The word “Engineer” shall mean the Town Engineer of the Town of Arlington, acting directly or through an authorized representative acting within the scope of the particular duties entrusted to him.

### **2. Parts of Contract**

It is agreed that the Information for Bidders, the Proposal submitted by the Contractor, the General Conditions, the Special Provisions, the Specifications, the Contract Drawings/Plans, and all Addenda are made parts of this contract.

The table of contents, titles, indexes, and headings contained herein and in said documents is solely to facilitate reference to various provisions of the Contract Documents and in no way affect, limit or cast light on the interpretation of the provisions to which they refer.

### **3. Obligations of the Contractor**

The contractor shall do all the work and furnish all services, tools, equipment, appliances, plant and labor necessary and furnish all materials except as may be otherwise specified herein, necessary or proper for performing and completing the work required by this Contract, with appurtenances of every kind complete in the manner and within the time specified.

All work to be performed and materials to be furnished under this contract shall be performed, furnished and completed pursuant to and strictly in conformance with the contract drawings, sometimes referred to herein as the “plans”, the attached specifications, and the directions of the Engineer as given from time to time during the progress of the work. The Contractor shall complete the entire work in accordance with the specifications and drawings herein mentioned and at the prices herein agreed upon and therefore fixed.

### **4. Liability of the Contractor**

The Contractor shall take all responsibility for the work done under this contract, for the protection of the work, and for preventing injuries to persons and damage to property and utilities on or about the work. He shall in no way be relieved of his responsibility by any right of the Engineer to give permission or directions relating to any part of the work, by any such permission or directions given, or by failure of the Engineer to give such permission or direction.

The Contractor shall bear all losses resulting to him or the Town on account of the quantity or character of the work, because the nature of the land in or on which the work is done is different from what was estimated or expected, or on account of the weather, elements, or other causes.

The Contractor shall assumed the defense of all claims of whatsoever character against the Contractor or the Town and indemnify and save harmless the Town, its officers, or agents against all claims for injury or damage to persons, corporations, or property arising out of the work done under this contract whether said claims arise out of negligence or not, or whether said claims are groundless, false, or fraudulent or not, and from all claims relating to labor and materials furnished for the work.

---

The Contractor shall conduct his operations so as not to damage existing structures or work installed either by him or by other contractors. In case of any such damage resulting from his operations, he shall repair and make good as new the damaged portions at his own expense with the consent of the damaged party. In the event that consent is not given, the Contractor shall not be relieved thereby of liability for the damage caused.

## **5. Authority of the Engineer**

The Engineer shall have the authority to stop the work whenever such stoppage may be necessary in his opinion to prevent improper execution of the work.

The sequence of execution of the work and the general conduct of the work shall be subject to the approval of the Engineer who shall have authority to direct changes be made in such sequence where public necessity or welfare shall require, which approval or direction shall, however, in no way affect the responsibility of the Contractor in the conduct of the work.

Whenever the Contractor is not present on any part of the work where it may be necessary to give directions, such directions may be given by the Engineer and shall be received and obeyed by the superintendent or foreman who may have charge of the particular work involved.

## **6. Engineer to Decide**

The Engineer shall make all necessary interpretations as to the meaning and intention of the Contract Drawings, Specifications, and other parts of this Contract. He shall give all orders and directions contemplated therein or thereby, and in every case in which a difficult or unforeseen condition shall arise in the performance of the work required by this contract.

The Engineer shall in all cases determine the amount, quality, acceptability and fitness of the several kinds of work and materials which are to be paid under this contract, and shall decide all questions which may arise as to the fulfillment of this contract. In the event that a determination or decision of the Engineer is questioned by the Contractor, the decision of the Engineer shall be a condition precedent to the Contractor's right to receive any money for the work or materials to which the question or difference in opinion relates.

## **7. Time for Commencing Work**

The Contractor shall commence the work within thirty (30) calendar days after signing the contract, or as directed by the Town.

Such time of starting may be postponed by written agreement between the Town and the Contractor because of expected delays in receipt of materials and equipment, if the season is unsuitable for commencement of the work, or because of any other contingency clearly beyond the control or responsibility of the Contractor. Unless stipulated otherwise in said agreement, the Contractor shall commence work at such points as the Engineer may direct or approve within thirty (30) calendar days after the receipt of a written order from the Town to start work.

## **8. No Damages for Certain Delays**

The Town may delay the commencement of the work, or any part thereof, for the reason that it has not acquired the necessary land or rights of way, or for any other reason. The Contractor shall have no claim for damages on account of such delay, or on account of any delay on the part of the Town in performing any work or furnishing any materials to the Contractor, or due to extra work required, but he shall be entitled to so much additional time in which to complete the whole or any portion of the work required under this contract. The Contractor shall have no claim for damages on account of any delay on the part of another contractor, but shall have such additional time in which to complete the work.

---

## **9. Time for Completion**

The rate of progress shall be such that the whole work shall be performed in accordance with the terms of this contract before the expiration of the time limit stipulated under special conditions, unless and except as any part may be delayed under the provisions of this contract.

It is agreed that the rate of progress herein required has been purposely made long enough to allow for the ordinary delays incident to construction work of this character. No extension of time will be made for ordinary delays, inclement weather, and accidents, and the occurrence of such will not relieve the Contractor from the necessity of maintaining this rate of progress.

If delays are caused by acts of God, acts of Government or State, strikes, extra work, or other contingencies clearly beyond the control or responsibility of the Contractor, the Contractor shall be entitled to so much additional time where in to perform and complete this contract on his part as the Engineer shall certify in writing to be just.\*

\*This paragraph will be interpreted to include delays in receipt of equipment provided that the Contractor placed his order and submitted shop drawings for such equipment promptly after execution of the contract, that he has shown diligence in following the progress of the order, and that the time required for delivery is in accordance with conditions generally prevailing in the industry.

The time in which this contract is to be performed and completed is of the essence of this agreement.

## **10. Competent Men to be Employed**

The Contractor shall have as his agent on the work a competent superintendent capable of reading and thoroughly understanding the drawings and specifications. The superintendent on the work shall have full authority to execute the directions of the Engineer without delay and supply promptly such materials, equipment, tools, labor, and incidentals as may be required.

The Contractor shall employ only competent men to do the work, and whenever the Engineer shall notify the Contractor in writing that any man on the work is, in his opinion, incompetent, unfaithful, disorderly or otherwise unsatisfactory, such man shall be discharged from the work and shall not again be employed on it except with the consent of the Engineer.

## **11. Access to Work**

The Town, its agents and employees may at all times enter upon the work or premises used by the Contractor, and the Contractor shall provide safe and proper facilities for such entrance and for the inspection of materials, equipment and workmanship.

Other contractors of the Town may also, for the purpose which may be required by their contracts or work, enter upon the work and premises used by the Contractor. Any differences or conflicts which may arise between the Contractor and other contractors of the Town in regard to their work shall be determined and adjusted by the Engineer.

## **12. Defective Work, Materials or Equipment**

The inspection of the work shall not relieve the Contractor or any of his obligations to fulfill his contract as herein prescribed, and defective work shall be made good and unsuitable materials or equipment shall be rejected, notwithstanding that such work, and materials or equipment have been previously overlooked by the Engineer and accepted or estimated for payment or paid for. If the work or any part thereof shall be found defective at any time before the final acceptance of the whole work, or the final payment therefore, the Contractor shall forthwith make good such defect, in a manner satisfactory to the Engineer; if any material or equipment brought upon the ground for use in the work, or selected for the same, shall be condemned by the Engineer as unsuitable or not in conformity with the specifications, the Contractor shall forthwith remove such

---

materials or equipment from the vicinity of the work, and any material furnished by the Town which shall be damaged or rendered defective by the handling or improper installation by the Contractor, his agents, or employees shall be made good and replaced at the Contractor's own expense.

### **13. Mistakes of Contractor**

The Contractor shall make good any defects, omissions, or mistakes for which he or his employees are responsible at his own cost, or he shall pay to the Town all expenses, losses, and damages incurred therefrom as determined by the Engineer.

### **14. Discrepancies, Errors and Omissions**

The drawings and specifications are intended to be explanatory of each other, but, should any discrepancy appear or any misunderstanding arise as to the import of anything contained in either, the interpretation and decision of the Engineer shall be final and binding on both parties to this contract.

Any correction of errors or omissions in drawings and specifications may be made by the Engineer when such correction is necessary for the proper fulfillment of their intention as construed by him. Where said correction of errors or omissions, except as provided in the next two paragraphs below, adds to the amount of work to be done by the Contractor, compensation for said additional work shall be made under the item for Extra Work except, where the additional work may be classed under some item of work for which a unit price is included in the PROPOSAL.

The fact that specific mention of a fixture or of any part of the work is omitted in the specifications, whether intentionally or otherwise, when the same is clearly indicated on the drawings, or is usually and customarily required to complete fully such work as is specified herein, will not entitle the Contractor to consideration in the matter of any claim for extra compensation, but the said fixtures or work or both shall be installed or done the same as if called for both by the drawings and by the specifications.

All work mentioned in the specifications and not indicated on the drawings, or vice versa, and all work and material usual and necessary to make the work complete in all its parts, whether or not they are mentioned in the specifications, or indicated on the drawings, shall be furnished and executed the same as if they were called for both by the specifications and by the drawings.

### **15. Right to Materials**

All materials shall become the property of the Town after they have been affixed or attached to the soil or to the work, and nothing in this contract shall be construed as vesting in the Contractor any right or property in the materials after their being so affixed or attached.

### **16. Compliance with Laws, Ordinances, and Regulations**

The Contractor shall keep himself fully informed of all existing and future State and National laws and municipal ordinances and regulations in any manner affecting those engaged or employed in the work, the materials used in the work, or the conduct of the work, and of all such orders and decrees of bodies or tribunals having any jurisdiction or authority over the same. If any discrepancy or inconsistency is discovered in the plans, drawings, specifications, or contract for this work, in relation to any such law, ordinance, regulation, order or decree, he shall forthwith report the same to the Engineer in writing. He shall at all times himself observe and comply with, and cause all his agents and employees to observe and comply with, all such existing and future laws, ordinances, regulations, orders and decrees; and he shall protect and indemnify the Town, its officers, and agents against any claim or liability arising from or based upon violation of any such law, ordinance, regulation, order, or decree, whether by himself or his employees.

---



## 17. Provisions Required by Law Deemed Inserted

Each and every provision of law and clause required by law to be inserted in this contract shall be deemed to be inserted herein and the contract shall be read and enforced as though it were included herein, and if through mistake or otherwise any such provision is not inserted, or is not correctly inserted, then upon the application of either party the contract shall forthwith be physically amended to make such insertion or correction.

## 18. Work Hours

General work hours shall be as follows:

- Monday - Friday from 7:00 AM - 4:00 PM.

No work shall be done at night or on Sunday except:

- 1) Usual protective work, such as pumping and the tending of lights and fires;
- 2) Work done in case of emergency threatening injury to persons or property;
- 3) If all of the conditions set forth in the next paragraph below are met.

No work other than that included in 1 and 2, above, shall be done at night except when:

- a) In the opinion of the Engineer, the work will be of advantage to the Town and can be performed satisfactorily at night;
- b) The work shall be done by a crew organized for regular and continuous night work;
- c) The Engineer has given written permission for such night work.

## 19. Intoxicating Liquors

The contractor shall not sell and shall neither permit nor suffer the sale, the introduction or use of intoxicating liquors upon or about the work under this contract.

## 20. Permits and Notices

The Contractor shall, at his own expense, take out all necessary permits from the county, municipal, or other public authorities; shall give all notices required by law or ordinances; and shall post all bonds and pay all fees and charges incident to the due and lawful prosecution of the work covered by this contract.

## 21. Patents

The Contractor shall indemnify and save harmless the Town and all persons acting for or on behalf of the Town from all claims and liability of any nature or kind, including costs and expenses, arising from or occasioned by any infringement or alleged infringement of patent rights on any invention process, article, or apparatus, or any part thereof, furnished and installed by said Contractor or arising from or occasioned by the use of manufacture thereof, including their use by the Town.

## 22. Insurance

The Contractor shall not commence work under this contract until he has obtained all the insurance required under this paragraph and such insurance has been approved by the Town, nor shall the Contractor allow any subcontractor to commence work on his subcontract until the insurance required of the subcontractor has been so obtained and approved.

- A. Compensation Insurance: The Contractor shall procure and shall maintain during the life of this contract Workmen's Compensation Insurance as required by applicable State or territorial law for all of his employees to be engaged in work at the site of the project under this contract and, in case of any such work sublet, the Contractor shall require the subcontractor similarly to provide Workmen's Compensation Insurance for all of the latter's employees to be engaged in such work unless such employees are covered
-

by the protection afforded by the Contractor's Workmen's Compensation Insurance. In case any class of employees engage in hazardous work on the project under this contract is not protected under the Workmen's Compensation Statue, the Contractor shall provide adequate employer's liability insurance for the protection of such of his employees as are not otherwise protected.

- B. Contractor's Public Liability and Property Damage Insurance: The Contractor shall maintain during the life of this contract Contractor's Public Liability Insurance and Contractor's Property Damage Insurance to the limits specified under SPECIAL CONDITIONS.
- C. Subcontractor's Public Liability and Property Damage Insurance: The Contractor shall either (1) require each of his subcontractors to procure and to maintain during the life of his sub-contract, Subcontractor's Public Liability and Property Damage Insurance of the type and to the limits specified under SPECIAL CONDITIONS or, (2) insure the activities of his subcontractors in his policy, specified in subparagraph (b) hereof.
- D. Scope of Insurance: The insurance required under sub-paragraphs (b) and (c) hereof shall provide adequate protection for the Contractor and his subcontractors, respectively, against damage claims which may arise from operations under this contract, whether such operations be by the insured or by anyone directly or indirectly employed by him.
- E. Proof of Carriage of Insurance: The Contractor shall furnish the Town with certificates showing the type, amount, class of operations covered, effective dates and dates of expiration of policies. Such certificates shall also contain substantially the following statement: "The insurance covered by this certificate will not be cancelled or materially altered, except after fifteen (15) days written notice has been received by the Town." If the initial insurance expires prior to completion of the work, renewal certificates shall be furnished by the date of expiration.

### **23. Work Not to be Sublet or Assigned**

The Contractor shall not give his personal attention constantly to the faithful prosecution of the work, shall keep the same under his personal control, and shall not assign by power of attorney or otherwise, or sublet, the work or any part thereof without the previous written consent of the Town, and shall not, either legally or equitably, assign any of the moneys payable under this agreement, or his claim thereto, unless by and with the like consent of the Town and the Surety on the Bonds.

### **24. Alterations**

The Engineer may in written order, and not otherwise, make alterations in the line, grade, plan, form, dimension or materials of the work, or any part thereof, either before or after the commencement of construction. If such alterations make the work less expensive to the Contractor, a proper deduction shall be made from the contract price, said deduction to be computed on the same basis as that specified under Extra Work for determining the value of approved extra work, unless there be applicable unit prices established by this contract, in which event the unit prices shall prevail.

The Contractor shall have no claims for damages or for anticipated profits on the work that thus may be dispensed with. (If such alterations make the work more expensive, a proper addition computed in the aforementioned manner shall be made to the contract price. Any such deduction or addition shall be determined by the Engineer.)

### **25. Extra Work**

The Contractor shall do any work not herein otherwise provided for, when and as ordered in writing by the Town or his agents specially authorized thereto in writing, and shall, when requested by the Town so to do, furnish itemized statements of the cost of the work ordered and give the Town access to accounts, bills and vouchers relating thereto.

---

If the Contractor claims compensation for extra work not ordered as aforesaid, or for any damage sustained, he shall within one week after the beginning of any such work or of the sustaining of any such damage, make a written statement of the nature of the work performed or damage sustained, to the Town and shall on or before the fifteenth day of the month succeeding that in which any such extra work shall have been done or any such damage shall have been sustained, file with the Town an itemized statement of the details and amount of such work or damage: and unless such statements shall be made as so required, his claim for compensation shall be void, and he shall not be entitled to payment on account of any such work or damage. The Contractor shall not include in the cost of extra work any cost or rental of small tools, buildings, or any portion of the time of the Contractor, his superintendent, or his office and engineering staff.

In the alternative, the extra work order may provide that the Contractor shall receive an amount equal to the actual cost of such extra work computed on the basis of the foregoing sub-sections (a) through (g) but limited by a predetermined lump sum maximum amount.

The determination of the Town shall be final upon all questions of the amount and value of extra work, provided that such extra work has been performed under a work order approved in writing by the Town as required by the terms of this contract.

The Town shall pay and the Contractor shall receive for everything furnished and done by the Contractor to the satisfaction of the Town under an approved extra work order a predetermined lump sum amount computed on the basis of the following:

- A. the actual cost of labor employed directly on the work at prevailing rates of wages.
- B. the cost of the amounts of additional premium paid on the required insurance on account of such extra work, of Social Security or other direct assessments upon the Contractor's payroll by Federal or other properly authorized public agencies, and of other approved assessments when such assessments are not normally included in payments made by the Contractor directly to his employees, but are recognized to be part of the cost of doing work.
- C. the reasonable cost of materials incorporated in the work.
- D. the reasonable cost at fair market rental rates for equipment employed directly on the work.
- E. 15% of (a) (b) (c) and (d) for overhead and profit. (On subcontract work, this 15% will be allowed only to the subcontractor).
- F. an additional 5% of (a) (b) (c) (d) and (e) on work performed by a subcontractor of the Contractor.

## **26. Extension of Time on Account of Extra Work**

When extra work is ordered near the completion of the contract or when extra work is ordered at any time during the progress of the work which requires in the opinion of the Engineer an unavoidable increase of time for the completion of the contract, a suitable extension of the time for completion shall be made.

## **27. Changes Not to Affect Bonds**

It is agreed and understood that any changes made in the drawings and specifications for this work (whether such changes increase or decrease the amount thereof) or any change in the manner or time of payments made by the Town to the Contractor shall in no way annul, release, or affect the liability and surety on the bonds given by the Contractor.

## **28. Completion of Work if Contract is Not Fulfilled**

If the Contractor shall be adjudged bankrupt, or if he shall make a general assignment for the benefit of his creditors, or if a receiver shall be appointed of his property, or if the work to be done under this contract shall be abandoned, or if this contract or any part thereof shall be sublet without the previous written consent of the

Town, or if the contract or any claim there under shall be assigned by the Contractor otherwise than as herein specified, or if at any time the Engineer shall be of the opinion, and shall so certify in writing to the Town that the conditions herein specified as to the rate of progress are not fulfilled, or that the work, or any part thereof, is unnecessarily or unreasonably delayed, or that the Contractor has violated any of the provisions of this contract, the Town may terminate to contract and hold the Contractor and his sureties liable in damages as for a breach of contract by an abandonment thereof by him, or the Town may notify the Contractor to discontinue all work, or any part thereof; and thereupon the Contractor shall discontinue all work, or any part thereof, as the Town may designate and the Town may thereupon, by contract or otherwise, as it may determine, complete the work, or such part thereof, and charge the entire expense for so completing the work, or part thereof, to the Contractor: and for such completion the Town, for itself or its contractors, may take possession of and use or cause to be used in the completion of the work or part thereof any of such materials, machinery, implements and tools of every description as may be found upon the line of said work. The Town may, at its option, require the surety or sureties to complete the contract. The Town shall not be liable for any depreciation, loss or damage to said materials, machinery, implements or tools during said use, nor until such as are not incorporated in the work are removed by the Contractor after completion of the work. Unless so removed within fifteen days after mailing of notice so to do, they may be sold at public auction, after publication of notice thereof at least twice in any newspaper published in the county where the work is being performed, and the proceeds credited to the Contractor's account; or they may, at the option of the Town, be stored at the Contractor's expense subject to a lien for the storage charges.

If the Engineer shall certify as aforesaid as to the rate of progress, the Town may, instead of notifying the Contractors to discontinue all work or any part thereof, notify him from time to time to increase the work force, equipment and plant, or any of them, employed on the whole or any part of the work, stating the amount of increase required; and unless he shall, within five days after any such notice, increase his force, equipment and plant to the extent required therein, and maintain and employ the same from day to day until the condition as to the rate of progress shall, in the opinion of the Engineer, be fulfilled, the Town may employ and direct the labors of such additional force, equipment and plant as may, in the opinion of the Engineer, be necessary to insure the completion of the work or such part thereof within the time herein specified, or at the earliest possible date thereafter, and charge the expense thereof to the Contractor. Neither the notice from the Town to the Contractor to increase his force, equipment or plant, nor the employment of additional force, equipment or plant by the Town shall be held to prevent a subsequent notice from the Town to him to discontinue work under the provisions of the preceding portion of this section.

All expenses charged under this section shall be deducted and paid by the Town out of any moneys then due or to become due the Contractor under this contract, or any part thereof; and in such accounting the Town shall not be held to obtain the lowest figures for the work of completing the contract or any part thereof, or for ensuring its proper completion, or for the additional force, equipment or plant that may be employed, but all sums actually paid therefore shall be charged to the Contractor. In case the expenses so charged exceed the sum that would have been payable under this contract if the same had been completed by the Contractor, the Contractor shall pay the amount of the excess to the Town, upon completion of the work, without further demand being made therefore.

## **29. Compensation for Work**

The Town shall pay, and the Contractor shall receive, the prices stipulated in the Proposal attached hereto as full compensation for everything furnished and done by the Contractor under this contract, including all work required but not specifically mentioned, and also for all loss or damage arising out of the nature of the work aforesaid, or from the action of the elements, or from any unforeseen obstruction or difficulty encountered in the prosecution of the work, and for all risks of every description connected with the work, and for all expenses incurred by or in consequence of the suspension or discontinuance of the work as herein specified and for well and faithfully completing the work, and the whole thereof, as herein provided.

---

### **30. Money may be Retained**

The Town may keep any money which would otherwise be payable at any time hereunder; may apply the same or so much as may be necessary therefore to the payment of any expenses, losses, or damages incurred by the Town and determined as herein provided; and may retain, until all claims are settled, so much of such money as the Town is of the opinion will be required to settle all claims filed with the Town, its officers, and agent relating to this contract.

### **31. Estimates and Payments**

The Engineer shall, on or about the first day of each month, except as hereinafter provided, make an estimate in writing of the total amount and value of the work done to the first of the month by the Contractor. The Town shall retain a percentage of such estimated value, as set forth under SPECIAL CONDITIONS, as part security for fulfillment of this contract by the Contractor and shall deduct from the balance all previous payments and all sums to be retained under the provisions of this contract. The Town shall pay monthly to the Contractor the balance not retained as aforesaid, except that payment may be withheld at any time if the work is not proceeding in accordance with the contract. The Town may cause estimates and payments to be made more frequently than once in each month.

Estimates of lump-sum items shall be based on a schedule dividing each item into its appropriate component parts together with a quantity and a unit price for each part such that the sum of the products or prices and quantities will equal the contract price for the item. This schedule shall be submitted by the Contractor for the approval of the Engineer before the first estimate becomes due.

If the Engineer determines that the progress of the work will be benefited by the delivery to the site of certain materials and equipment, when available, in advance of actual requirement therefore and if such materials and equipment are delivered and properly stored and protected, the cost to the Contractor or subcontractor as established by invoices or other suitable vouchers may be included in the estimates.

The Engineer shall, as soon as practicable (but not more than 65 days) after the completion of the work under this contract, make a final estimate in writing of the quantity of work done under the contract and the amount earned by the Contractor. The Engineer also shall fix the date of completion of said work and incorporate the same into final estimate.

The Town shall pay to the Contractor the entire sum found to be due hereunder after deducting therefrom all previous payments, all amounts to be kept, and all amount to be retained under the provisions of this contract. Such payment shall be made not later than 15 days after, but in no event before the expiration of the time within which claims for labor performed and materials used or employed must be entered under the Lien Law, or, if such time is not specified by law, the expiration of 30 days after the completion of the final estimate.

All quantities shown on progress estimates and all prior payments shall be subject to correction in the final estimate and payment.

### **32. Partial Payment Not Acceptance**

It is agreed that this is an entire contract for one whole and complete work and that no partial payments on account by the Town nor the use of parts of the proposed equipment shall constitute an acceptance of any part of the work before its entire completion and final acceptance.

### **33. Liens**

If at any time before the expiration of the period within which claims must be entered under the Lien Law, or if not otherwise specified by law, within 30 days after the whole work herein agreed to be delivered have been performed, delivered, or completed and accepted by the Town, any person or persons claiming to have performed any labor or furnished any materials toward the performance or completion of this contract shall file

---

with the Town suitable notice, the Town shall retain, until the discharge thereof, from the moneys under its control so much of such money as sufficient to satisfy and discharge the amount claimed to be due in such notice, together with the cost of any action or actions brought to enforce such lien created by the filing of such notice.

### **34. Waiver**

Neither the inspection by the Engineer, nor any act of thing done by the Town or its agents other than an express waiver by vote of the Town shall operate as a waiver of any provision of this contract; nor shall any waiver of any breach of this contract be held to be a waiver of any other subsequent breach. Any remedy provided in this contract shall be taken and construed as cumulative; that is in addition to each and every other remedy herein provided.

### **35. Liability of the Town of Arlington**

No person, firm, or corporation, other than the signer of this contract as Contractor, now have any interest hereunder; no claim shall be made or be valid; and neither the Town nor any agent of the Town shall be liable for or be held to pay any money, except as herein provided. The acceptance by the Contractor of the payment of the final estimate shall operate as and shall be a release to the Town and every agent of the Town from all claim and liability to the Contractor for anything done or furnished for or relating to the work or for any act or neglect of the Town or of any person relating to or affecting the work, except the claim against the Town for the remainder, if there is any, of the amounts kept or retained as herein provided.

### **36. Guarantee**

The Contractor guarantees that the work to be done under this contract, and the workmanship performed and the materials and equipment used in the construction of the same, shall be free from defects or flaws, that each item of equipment shall be in accordance with the specifications, that the strength of all parts of all manufactured equipment shall be adequate and that the performance test requirements of the specifications shall be fulfilled. This guarantee shall be for a period of one year from and after the date of completion of the work as stated in the final estimate. The Contractor shall repair or replace as required, promptly and without charge, all work, equipment, and material, or parts thereof, which fail to meet the above guarantee during one year herein quoted.

It is hereby, however, agreed and understood that this guarantee shall not include any repairs or replacements made necessary by any cause or causes other than improper, inadequate, or defective work, workmanship, materials, or design by the Contractor or those employed directly or indirectly by him.

### **37. Money Retained for Repairs**

The Town may retain out of the monies payable to the Contractor under the contract a sum as set for under SPECIAL CONDITIONS and may expend the same, in the manner hereinafter provided, in making such repairs or replacements of said work as the Town may deem expedient.

If at any time within the said period of guarantee any part of the work constructed under the terms of this contract requires repairing or replacement, the Town may notify the Contractor in writing to make the required repairs or replacements. If the Contractor neglects to make such repairs or replacements to the satisfaction of the Town within ten (10) days from the date of receipt of such notice, the Town may employ other persons to make the same. The Town shall pay the expense of the same out of the sum retained for that purpose. Upon expiration of the said period of guarantee, provided that the work at the time is in good order, the Contractor will be entitled to receive the whole or such part of the sum last aforesaid as may remain after the expense of making said repairs or replacements, in the manner aforesaid, has been paid therefrom.

It is agreed that the Town may keep the whole or any portion of the sum retained for settlement of all claims arising out of this contract against the Town, its officers, or agents and for all expenses, losses, or damages incurred by the Town by reason of said claims.

---

### **38. Address of Contractor**

The Contractor's business address and his office at or near the site of the work are both hereby designated as places to which communications shall be delivered. The depositing of any letter, notice, or other communication in a postpaid wrapper directed to the Contractor's business address in a post office box regularly maintained by the Post Office Department or the delivery at either designated address of any letter, notice, or other communication by mail or otherwise shall be deemed sufficient service thereof upon the Contractor. The first-named address may be changed at any time by an instrument in writing, executed and acknowledged by the Contractor and delivered to the Engineer. Nothing herein contained shall be deemed to preclude or render inoperative the service of any notice, letter, or other communication upon the Contractor personally.





## **VI. GENERAL CONDITIONS**

### **1. Definitions**

The words “directed”, “required”, “permitted”, “ordered”, “designated”, “prescribed”, or words to like import shall mane the directions, requirement, permission, order, designation, prescription, etc. of the Engineer and similarly the words “approved”, “acceptable”, or “satisfactory”, or words of like import shall man approved by or acceptable or satisfactory to, the Engineer, subject in each case to the final determination of the Town unless otherwise expressly stated.

The word “rock” wherever used as the name of material excavated or to be excavated, shall man the sound bedrock, properly removed by blasting, wedging or barring, also such boulders exceeding three-quarters of a cubic yard in volume removed from the excavations, also any portions of existing masonry structures removed from the excavations. Sound bedrock shall not include any rock disintegrated or fractured, in the opinion of the Engineer, to such an extent as to be easily removable by pick and shovel. The word “boulders” as used above shall include loose, detached fragments or portions of ledge and only such fragments or portions as exceed the specified three-quarters of a cubic yard limit shall be included in the classification of “rock”.

The word “earth” wherever used as the name of an excavated material or material to be excavated, shall mean all kinds of material not defined as “rock” in the above paragraph.

### **2. Abbreviations**

Wherever in the specifications, or on the drawings, any of the abbreviations which follow are used they shall have the following meaning:

AASHO	- American Association of State Highway Officials
ACI	- American Concrete Institute
AIEE	- American Institute of Electrical Engineers
AISC	- American Institute of Steel Construction
ASA	- American Standards Association
ASCE	- American Society of Civil Engineers
ASH&AE	- American Society of Heating and Air Conditioning Engineers
ASME	- American Society of Mechanical Engineers
ASTM	- American Society for Testing Materials
AWWA	- American Water Works Association
NBS	- National Bureau of Standards
NEC	- National Electrical Code, latest edition
NEMA	- National Electrical Manufacturers Association

### **3. Handling Materials**

The Contractor shall at his own expense handle, haul and distribute all materials and equipment used and employed on the different portions of the works as required. Storage charges and demurrage charges by vendors and transportation companies, which result from delays in handling, shall be borne by the Contractor.

### **4. Storage Room**

The Contractor shall provide suitable and adequate storage room for all materials during the progress of the work, and shall obtain the consent of the proper parties before entering or occupying with men, tools, or materials, any private land outside of the property or rights of way of the Town.

## **5. Shop Drawings, Schedules, and Descriptive Matter**

The Contractor shall furnish, as hereinafter required, all specified shop and details drawings. All drawings required shall be submitted in triplicate to the Engineer for review and in quadruplicate after review.

The review by the Engineer of such drawings and details will be general and shall not relieve the Contractor of the responsibility for executing the entire work in accordance with the specifications and contract drawings. [Failure on the part of the Engineer to detect errors or omissions on shop drawings shall not relieve the Contractor from the responsibility for such errors or omissions.]

Should the contractor submit for review equipment that requires modifications to the structures, piping, layout, etc. detailed on the contract drawings, he shall also submit for review details of the proposed modifications. If such equipment and modifications are allowed, the Contractor, as not additional cost to the Town, shall do all work necessary to make such modifications.

The Contractor shall also furnish for the Engineer's review, all lists, schedules, and information regarding materials, fixtures and equipment as hereinafter required and specified.

All such lists, schedules, etc., shall be submitted to the Engineer for reviews within fifteen (15) days following execution of the contract. Following review by the Engineer of such materials, fixtures, and equipment, the Contractor shall promptly place orders for the equipment. Order shall be placed within seven (7) days following the Engineer's review and proof of such order shall be furnish to the Engineer.

## **6. Equivalents**

Whenever the specifications define the material or article required by using the name of a proprietary product or of a manufacture or vendor rather than by using descriptive detail of substance and functions, the words "or equivalent" are to be understood to follow immediately the make of the maker, vendor or proprietary product. The words "or equivalent" shall be interpreted as including any material or article which, in the opinion of the Engineer, is equivalent in quality, durability, appearance, strength and design to the article named and which will perform adequately the functions imposed by the general design.

Whenever in the specifications the names of manufacturers are mentioned as indicating that their products will comply with a particular specification, or when specific trade names or plated numbers or letters are mentioned, it is not intended to exclude products of other manufacturers whose names, trade names or symbols have not been mentioned, provided however, that such products otherwise comply, in the opinion of the Engineer, with the specifications. The Engineer's opinion in all cases mentioned in this section shall be final.

## **7. Materials and Workmanship**

All materials and equipment furnished under this contract shall be of standard high-grade quality and of the best workmanship and design. No inferior or low-grade materials will be accepted, and all work must be done in a neat, first-class and workmanlike manner.

The Engineer shall have the right to test and inspect or require certificates of tests of any materials to be used in the work.

## **8. Inspection by the Engineer**

All materials and equipment furnished and work done by the Contractor shall be subject to inspection by the Engineer, and defective materials shall be removed from the site of the work and defective work repaired or replaced as directed. Facilities for inspection of the work shall at all times be furnished by the Contractor.

## **9. Documents at Site of Work**

The Contractor shall have available at all times, at the site of the work, copies of the contractor documents, any plans and all standard specifications of the various associations which are referred to in the specifications.

## **10. Lines and Grades**

The Engineer shall establish such control stations, base lines and bench marks as may be necessary for the use of the Contractor. It shall be the specific duty of the Contractor to preserve and to protect the control base lines and bench marks so established.

During construction, the Contractor shall use the control stations, base lines and bench marks established by the Engineer to develop his own lines and grades as needed to comply with those specified or shown on the drawings. The Contractor shall be held responsible for all lines and grades which he has developed.

## **11. Scaffolding and Protection**

The Contractor shall provide safe scaffolding to accommodate the work. He shall build all necessary runways, temporary stairs, ladders, barricades, fences, etc.

## **12. Public Safety and Property of Others**

The Contractor shall make all necessary provisions to protect the public safety, and maintain and protect existing structures of whatever kind, and shall repair all damage done to such structures. He shall give ample notification to the proper officials of any city or town, of any public utility, corporation, or other individual before entering upon their respective public ways or rights of way and shall conform to the customary regulations and requirements of said officials, corporations, or individuals.

Extra precautions must be taken to avoid splattering adjoining property, automobiles, or structures. The Contractor shall be fully responsible for all damages to same.

## **13. Existing Structures, Pipes, Conduits, Etc**

Any existing structures, pipes, conduits, wires, etc., shall be protected and if damaged shall be repaired by the Contractor without additional compensation.

## **14. Sanitary Provisions**

The Contractor shall provide and maintain in a neat and sanitary condition such accommodations for the use of his employees as may be necessary to comply with the requirements of the State Department of Public Health, local health officials, or other authorities having jurisdiction.

Every precaution shall be taken to prevent contamination or pollution of the ground at the site, or of any material or equipment which is to be incorporated in, or used in the construction of any work under this contract.

## **15. Cutting and Patching**

The Contractor shall do all cutting, patching, drilling, grouting, etc., as necessary to complete the work, whether such work is described in the specifications or not.

## **16. Debris**

Debris shall not be permitted to accumulate but shall be removed from the site of the work and disposed of by the Contractor.

## **17. Measurement of Quantities**

For the estimating of quantities in which the computation of areas by analytic and geometric methods would be comparatively laborious, it is stipulated and agreed that the planimeter shall be considered an instrument of precision adapted to the measurement of such areas.

For the purposes of measurement and computation of irregular volumes, the prismoidal formula shall be deemed a method of precision.

## **18. Compliance with Occupational Safety and Health Act of 1970**

The Contractor shall in the work of this contract comply with all pertinent standards and regulations established by the Occupational Safety and Health Administration, Department of Labor by the authority of the Williams-Steiger Occupational Safety and Health Act of 1970. This project is subject to all of the Safety and Health Regulations (see 29 CFR 1518) as promulgated by the U.S. Department of Labor on April 17, 1971. Contractors are urged to make themselves familiar with the requirements of these regulations.

## **19. Order of Precedence Governing Specifications**

The Standard Specifications for Highways and Bridges of the Commonwealth of Massachusetts, 1973 Edition plus any supplements shall be considered a part of these specifications.

In case of conflict between any sections of these specifications, plans, etc., the following order of precedence shall govern.

1. Special Provisions
2. Plans, Profiles, or Sections
3. Standard Specifications for Construction work in Arlington
4. Standard Specifications, 1973 Edition plus Supplements, for Highways and Bridges of the Commonwealth of Massachusetts.

## **20. Affirmative Action/Anti-Discrimination**

For the purposes of this contract, "minority" refers to Asian-American, Blacks, Spanish, Surnames Americans, North American Indians, and Cape Verdeans. Town refers to the Town of Arlington.

During the performance of this contracts, the Contractor and all of (his) Sub-contractors (hereinafter collectively referred to as the Contractor) for himself, his assignees, and successors in interest, agree as follows:

1. In connection with the performance of work under this contract, the Contractor shall not discriminate against any employee or applicant for employment because of race, color, religious creed, national origin, age or sex. The aforesaid provision shall include, but not be limited to, the following: employment upgrading, demotion, or transfer; recruitment advertising; recruitment layoff; termination; rates of pay or other forms of compensation; conditions or privileges of employment; and selection for apprenticeship. The Contractor shall post hereafter in conspicuous places, available for employees and applicants for employment, notices to be provided by the Town setting forth the provisions of the Fair Employment Practices Law of the Commonwealth (M.G.L. Chapter 151B).
2. In connection with the performance of work under this contract, the Contractors, shall undertake in good faith affirmative action measures designed to eliminate any discriminatory barriers in the terms and conditions of employment on the grounds of race, color, religious creed, national origin, age or sex, and to eliminate and remedy any effects of such discrimination in the past. Such affirmative action shall entail positive and aggressive measures to ensure equal opportunity in the areas of hiring, upgrading, demotion or transfer, recruitment, layoff or termination, rate of compensation, and in-service or apprenticeship training programs. This affirmative action shall include all action required to guarantee equal employment opportunity for all persons, regardless of race, color, religious creed, national origin, age or sex. A purpose of this provision is to ensure to the fullest extent possible an adequate supply of skilled tradesman for this and future Town public construction projects.
3. As part of his obligation of remedial action under the foregoing section, the Contractor shall maintain on this project a not less than five percent ration of minority employee man hours to

total man hours in each job category including but not limited to bricklayers, carpenters, cement masons, electricians, ironworks, operation engineers and those “classes of work” enumerated in Section 44C of Chapter 149 of the Massachusetts General Laws.

4. In the hiring of minority journeyman, apprentices, trainees and advances trainees, the Contractor shall rely on referrals from a multi-employer affirmative action program approved by the Town, traditional referral methods utilized by the construction industry, and referrals from agencies, not more than three in number at any one time, designated by the Liaison Committee or the Town.
5. At the discretion of the Town there may be established for the life of this contract a body to be known as the Liaison Committee. The Liaison Committee shall be composed of one representative each from the agency or agencies administering this project, hereinafter called the administering agency, the Town and such other representative as may be designated by the Town in conjunction with the administering agency.
6. The Contractor (or his Agent, if any, designated by him as the on-site equal employment opportunity officer) shall recognize the Liaison Committee as an affirmative action body, and shall establish a continuing working relationship with the Liaison Committee, consulting with the Liaison Committee on all matters related to minority recruitment, referral, employment and training.
7. The Contractor shall prepare projected manning tables on a quarterly basis. These shall be broken down into projections, by week, or workers required in each trade. Copies shall be furnished one week in advance of the commencement of the period covered, and also when updated, to the Town or Liaison Committee.
8. Records of employment referral orders, prepared by the Contractor, shall be made available to the Town and to the Liaison Committee on request.
9. The Contractor shall prepare weekly reports in a form approved by Town of hours worked in each trade by each employee, identified as minority or non-minority. Copies of these shall be provided at the end of each such week to the Town and to the Liaison Committee.

If the Contractor shall use any sub-contractor on any work performed under this contract, he shall take affirmative action to negotiate with qualified minority sub-contractors. This affirmative action shall cover both pre-bid and post-bid periods. It shall include notification to the Office of Minority Business Assistance (within the Executive Office of Communities and Development) or its designee, while bids are in preparation, of all products, work or services for which the Contractor intends to negotiate bids.

In the employment of journeymen, apprentices, trainees and advanced trainees, the Contractor shall give preference, first, to citizens of the Commonwealth who have served in the armed forces of the United States in time of war and have been honorably discharged there from or released from active duty therein, and who are qualified to perform the work to which the employment relates, and, secondly, to citizens of the Commonwealth generally, and, if such cannot be obtained in sufficient numbers, then to citizens of the United States.

A designee of the Town and a designee of the Liaison Committee shall each have right of access to the construction site.

## **21. Compliance with Requirements**

The Contractor shall comply with the provisions of Executive Order O, 74, as amended by Executive Order NO. 116 dated May 1, 1975, and of Chapter 151B as amended, of the Massachusetts General Laws, both of which are herein incorporated by preference and made a part of this contract.

## **22. Non-Discrimination**

The Contractor, in the performance of all work after award, and prior to completion of the contract work, will not discriminate on grounds of race, color, religious creed, national origin, age or sex in employment practices, in the selection or retention of sub-contractors, or in the procurement of materials and rentals of equipment.

## **23. Solicitations for Sub-Contracts, and for the Procurement of Materials and Equipment**

In all solicitations either by competitive bidding or negotiation made by the Contractor either for work to be performed under a sub-contract or for the procurement of materials or equipment, each potential sub-contractor or supplier shall be notified in writing by the Contractor of the Contractor's obligations under this contract relative to non-discrimination and affirmative action.

## **24. Bidders Certification Requirement**

1. The bidders certification form currently in use will be deleted from all future bid documents.
2. The following certification statement will be inserted in the bid document just above the bidders signature, as a substitute for the present bidder certification form:

“The bidder hereby certifies he shall comply with the minority manpower ratios and specific action steps contained in the appendix EEO attached hereto, including compliance with the minority contractor compliance specified in Section V of said appendix. The contractor receiving the award of the contract shall be required to obtain from each of its sub-contractors and submit to the contracting or administering agency prior to the performance of any work under said contract a certification by said sub-contractor, regardless of tier, that it will comply with the minority manpower ratio and specific affirmative action step contained in the appendix EEO.”

## **25. Contractor's Certification**

The Contractor's certification form must be signed by all successful low bidder(s) prior to award by the contracting agency. (See attachment).

## **26. Compliance-Information, Reports and Sanctions**

1. The Contractor will provide all information and reports required by the administering agency or the Town on instructions issued by either of them and will permit access to its facilities and pay books, records, accounts and other sources of information which may be determined by Town to affect the employment of personnel. This provision shall apply only to information pertinent to the Town's supplementary affirmative action contract requirements. Where information required is in the exclusive possession of another who fails or refuses to furnish this information, the Contractor shall so certify to the administering agency of the Town as appropriate and shall set forth what efforts he has made to obtain the information.
2. Whenever the administering agency, the Town, or the Liaison Committee believes the General Contractor or any Sub-contractor may not be operating in compliance with the terms of this Section, the Town directly, or through its designated agent, shall conduct an appropriate investigation, and may confer with the parties, to determine if such Contractor is operating in compliance with this Section. If the Town or its agent finds the General Contractor or any Sub-contractor not in compliance, it shall make a preliminary report on non-compliance, and notify such Contractor in writing of such steps as will in the judgment of the Town or its agent bring such Contractor into compliance. In the event that such Contractor fails or refuses to fully perform such steps, the Town shall make a final report of non-compliance, and recommend to the administering agency the imposition of one or more of the sanctions listed below. If, however, the Town believes the General Contractor or any Sub-contractor has taken or is taking every possible measure to achieve compliance, it shall not make a final report of non-compliance. Within fourteen (14) days of the receipt of the recommendations of the Town, the administering agency shall move to impose one or more of the following sanctions, as it may deem appropriate to attain full and effective enforcement:

- a. The recovery by the administering agency from the General Contractor of 1/100 of 1% of the contract award price or \$1000 whichever sum is greater, in the nature of liquidated damages or, if a Sub-contractor is in non-compliance, the recovery by the administering agency from the General Contractor, to be assessed by the General Contractor as a back charge against the Sub-contractor, of 1/10 of 1% of the sub-contract price, or \$400 whichever sum is greater, in the nature of liquidated damages, for each week that such party fails or refuses to comply.
  - b. The suspension of any payment or part thereof due under the contract until such time as the General Contractor or any Sub-contractor is able to demonstrate his compliance with the terms of the contract.
  - c. The termination, or cancellation, of the contract, in whole or in part, unless the General Contractor or any Sub-contractor is able to demonstrate within a specified time his compliance with the terms of the contract.
  - d. The denial to the General Contractor or any Sub-contractor of the right to participate in any future contracts awarded by the administering agency for a period of up to three years.
3. If at any time after the imposition of one or more of the above sanctions a Contractor is able to demonstrate that he is in compliance with this Section, he may request the administering agency, in consultation with the Town, to suspend the sanctions conditionally, pending a final determination by the Town as to whether the Contractor is in compliance. Upon final determination of the Town, the administering agency, based on the recommendation of the Town, shall either lift the sanctions or reimpose them.
  4. Sanctions enumerated under Sections 2 shall not be imposed by the administering agency except after an adjudicatory proceeding, as that term is used M.G.L. c. 30A has been conducted. No investigation by the Town or its agent shall be initiated without prior notice to the Contractor.

### **27. Severability**

The provisions of this section are severable, and if any of these provisions shall be held unconstitutional by any court of competent jurisdiction, the decision of such court shall not affect or impair any of the remaining provisions.

## **VII. SPECIAL PROVISIONS**

### **1. Scope of Work**

The Work under this Contract consists of furnishing all necessary labor, materials, equipment, & services required for the construction of sewer lines and manholes on Fessenden Road in the Town of Arlington. Prior to the commencement of the work, the Town of Arlington Engineering Division will mark the limits and locations of work in the field.

The estimate total value of this contract is projected to be \$75,000.00. Quantities are estimated and are provided only for the purpose of comparing bids. The Town of Arlington reserves the right to increase or decrease the estimated total value of this contract without any changes in the Contractor's unit bid prices.

All items of work in this contract shall be in conformance with the "Commonwealth of Massachusetts, Highway Department (MHD) Standard Specifications for Highway and Bridges", dated 2020, including the latest supplements and addendum thereto; the 2020 Construction Standards; the Arlington DPW Design & Construction Standards, the 2009 Manual on Uniform Traffic Control Devices and addendum thereto; the 1990 Standard Drawings for Signs and Supports; the 1968 Standard Drawings for Traffic Signals and Highway Lighting; the American Standards for Nursery Stock (ANSI Z 60.1 - 1986); and these Special Provisions.

### **2. Contract Requirements & Definitions**

The words "municipal" or "municipality" in this document shall mean the Town of Arlington.

The materials are subject to inspection prior to the awarding of a Contract. All materials shall meet or exceed the requirements as written in the Specifications.

No contract award will be deemed to be legally made until a completed and signed contract is executed. The Contractor shall comply with all state and local laws, ordinances and regulations governing the type of work called for in these specifications, particularly in reference to safety and fire regulations.

The Contractor must have a supervisor or foreman available at all times to direct operations. This supervisor or foreman will report to the Town any problems as well as give progress reports.

The Contractor must show by past performance that he is capable of performing a contract of this magnitude and must enclose a list of other contracts he has completed in other cities and towns.

The Contractor agrees not to sublet or assign the Contract in whole or in part without the written approval or the written authorization of the Town. However, nothing contained in this agreement shall create any contractual relationship between a subcontractor and the Town.

### **3. Schedule & Safety Measures for Construction Impacts**

Prior to any construction activities commencing, the Contractor shall coordinate a Pre-Construction meeting with the Town of Arlington Police Department and Town of Arlington Engineering Division to discuss scheduling, notification requirements, traffic management, and other job particulars.

Work, unless otherwise noted, is restricted to a ten-hour window, five-day week, with the Prime Contractor and all subcontractors working on the same shift. The daily work shift shall begin no sooner than 7:00 A.M. and shall end no later than 5:00 P.M.

No work shall be performed on Saturdays, Sundays, or Holidays without the expressed written approval of the Town and the concurrence of the Chief of Police, except in the situation of On-Call Emergency Services. Such approval shall be requested one week in advance of the date upon which the Contractor wishes to perform work.



**All work proposed under this contract shall be completed by NOVEMBER 15, 2021.** All prices submitted by the Contractor shall be fixed for the entire Contract period.

The Contractor shall perform the work to a schedule prepared by the Contractor and approved by the Town. All work shall be scheduled only at times acceptable to the Town. The Contractor shall indicate the amount of time required to perform the work and present a tentative schedule to complete such work (weather permitting).

The Contractor shall schedule the work in a manner that facilitates the completion of work at one location while starting the work at another. Excavation shall be limited to those areas that the Contractor can finish in a reasonable amount of time.

At the end of each workday, all safety control devices shall be in place so that traffic flow can resume and safety is enhanced. It is the Contractor's responsibility to provide all appropriate warning signs, reflectorized drums, flashers, and other safety control devices necessary. Street closures, lane closures, partial lane closures, and detours are all considered part of the traffic management measures required under the Contract.

Any detours proposed by the contractor must be submitted to the Town, Police and Fire Department of the Town of Arlington at least 72 hours prior to the implementation of the detour. The contractor must receive written approval of the detour prior to the commencement of the scheduled work. Each submitted detour plan shall conform to the relevant section of Part VI of the Manual for Uniform Traffic Control Devices (MUTCD)

#### **4. Qualification**

The Contractor shall be responsible for payment of prevailing wages for work performed as determined by the Director of Labor and Industries under the provisions of the Massachusetts General Laws, Chapter 149, Sections 26 to 27D.

#### **5. Inspection**

One or more inspectors may be assigned by the Town to oversee construction of the work, and shall have the authority to monitor the work. All costs associated with inspection shall be borne by the Town.

All extra work orders will require written approval by the Town before performing the work.

#### **6. Work by Others and Cooperation by the Contractor**

Agents of various Public Service Agencies, Municipal and State Departments may be entering on the work site to remove existing facilities, to construct or place new facilities or to make alterations to existing facilities.

The Contractor shall perform the work in cooperation with the various agencies in a manner, which causes the least interference with the operations of the aforementioned agencies and shall have no claim for delay, which may be due, or result, from said work of these agents.

The Contractor shall be fully responsible for arranging and coordinating his work that is to be performed by others. This coordination and phasing shall be submitted to the Town for his approval.

Work required on all private utilities made necessary by the construction of this project will be accomplished by the respective utility companies at no additional cost to the Town. Each utility company shall be responsible for their own safety control including detail officers if required

#### **7. Public Safety & Convenience**

The Contractor's attention is directed to the fact that work on this project is to be performed on streets, which are utilized by pedestrians as well as by vehicles. The Contractor shall be responsible for the installation of adequate precautions and other safety measures and controls deemed necessary by the Town for the Contractor's own personnel. Any automotive equipment not protected by traffic cones or plastic drums that is working on a public

way under this project shall have one amber flashing warning light mounted on the cab roof or in the highest practical point of the machinery. This light shall be in operation while the equipment is so working.

The Contractor shall be required, without additional compensation to provide safe and convenient access to all abutters during the prosecution of the work. Necessary access for fire apparatus and other emergency vehicles shall be maintained at all times. Sweeping and cleaning of surfaces beyond the limits of the project to clean up material caused by spillage or vehicular tracking during the various phases of the work shall be considered as incidental to the work being performed under the Contract and there will be no additional compensation.

## **8. Cleaning Up**

During its progress, the work and the adjacent areas affected thereby shall be kept cleaned and all rubbish, surplus materials, and unneeded construction equipment shall be removed and all damage repaired so that the public and property owners will be inconvenienced as little as possible.

Where material or debris has washed or flowed into or been placed in existing watercourses, ditches, gutters, drains, pipes structures, or elsewhere during the course of the Contractor's operations, such material or debris shall be entirely removed and satisfactorily disposed of during the progress of the work, and the ditches, channels, drains, pipes, structures, etc., shall, upon completion of the work, be left in a clean and neat condition.

On or before the completion of the work, the Contractor shall, unless otherwise especially directed or permitted in writing, tear down and remove all temporary buildings and structures built by him; shall remove all temporary works, tools, and machinery or other construction equipment furnished by him; shall remove, acceptably disinfect, and cover all organic matter and material containing organic matter in, under, and around privies, houses, and other buildings used by him; shall remove all rubbish from any grounds which he has occupied; and shall leave the roads and all parts of the premises and adjacent property affected by his operations in a neat and satisfactory condition.

The Contractor shall restore or replace, when and as directed by the Town, any public or private property damaged by his work, equipment, or employees, to a condition at least equal to that existing immediately prior to the beginning of operations. To this end the Contractor shall do as required all necessary highway or driveway, walk, and landscaping work.

Suitable materials, equipment, and methods shall be used for such restoration. The restoration of existing property or structures shall be done as promptly as practicable as work progresses and shall not be left until the end of the Contract period.

## **9. Provisions for Access at All Locations**

The Contractor shall cooperate with the various utility companies, public agencies and the municipality, and provide access through the site if required for their work or to observe work in connection with this project that affects their respective properties, but all official orders and directives to the Contractor will be issued by the Town or its duly appointed representative.

## **10. Provisions for Travel & Prosecution of the Work**

Before starting any work under the contract, the Contractor shall coordinate a pre-construction meeting with the Town of Arlington Engineering Division and Town of Arlington Police Department to discuss job particulars including an anticipated schedule of work. The work schedule shall include a plan of his construction procedures and the safety measures he will use during the prosecution of the work.

This plan shall indicate the temporary barricades, signs, drums, and other traffic control devices to be employed during the period of work to maintain traffic and pedestrian safety. Said plan shall conform to Part VI of the 2009 edition of the MUTCD.

Particular care should be taken to establish and maintain methods and procedures, which will not create unnecessary or unusual hazards to public safety. As necessary and/or as directed by the Town, uniformed traffic police shall be employed for the protection and maintenance of traffic. Reasonable facilities shall be provided by the Contractor for the convenient, safe passage of pedestrians and vehicles through the project, and also to and from properties abutting the site of improvement.

Particular care shall be exercised at all times to establish and maintain such methods of work on any roadway which would interfere with the existing flow of traffic shall be limited to approximately one-half width at any one time. At least one lane in each direction shall be kept open at all times. No detouring of traffic shall be allowed without permission of the Town and the Arlington Police Department.

The Contractor shall give notice in writing to the Town at least seven days in advance of beginning any work affecting the maintenance of traffic where work affects the streets in use by the public. The Contractor must prosecute the work efficiently and with the least possible delay. The Contractor is responsible for furnishing, erecting, and maintaining any the temporary signing of the roadways required of this project, and the proper removal of the signs upon the completion of the project.

Traffic Control devices required only during working hour operations shall be removed at the end of each working day.

Signs having messages that are irrelevant to normal traffic conditions shall be removed or properly covered at the end of each work period. Signs shall be kept clean at all times and legends shall be distinctive and unmarred. The Contractor shall provide all cones, barrels, barricades, signs, and such other devices as deemed necessary by the Town and in conformance with the traffic management plans prepared by the Town's consultant and Section VI of the MUTCD, as amended.

## **11. Traffic Orders**

Uniformed Traffic Officers may be required during the construction period. It shall be the responsibility of the Contractor to arrange for the necessary police details with the approval of the Engineering Division.

The Town will pay the exact charges for police details directly to the Arlington Police Department for details ordered by the contractor for this project.

If the Contractor fails to cancel any police detail not needed, by the required deadline as set forth by the Arlington Police Department, the cost for such detail as invoiced to the Town shall be deducted from the total reimbursement to the Contractor, unless otherwise waived by the Town due to conditions which are beyond the Contractors control.

## **12. Work Coordination & Abutter Notification**

The Contractor shall hand-distribute notices to all immediate abutters of the project at the direction of the Town at no additional cost to the Town. These notices will be prepared and provided by the Town. The distribution of these notices will be required one week prior to any construction activities commencing.

The Contractor shall also post and remove approved "No-Parking" signs on the site as required for the work at no additional cost to the Town. Upon request, appropriate signs can be provided to the Contractor by the Town for use on this project. These signs must be affixed by means acceptable to the Town.

## **13. Temporary Access to Area Abutters**

The Contractor's attention is directed to the fact that the work is in a predominantly residential and commercial business section of the Town and access to all residences and businesses must be maintained at all times.

The Contractor shall provide a safe and ready means of ingress and egress to all stores and shops, public and private buildings, professional offices and any other business or residence in the project area, both day and night, for the duration of the project.

#### **14. Storage of Materials & Equipment**

All excavated materials and equipment to be incorporated in the work shall be placed so as not to injure any part of the work or existing facilities and so that free access can be had at all times to all parts of the work and to all public utility installations in the vicinity of the work. Materials and equipment shall be kept neatly piled and compactly stored in such locations as will cause a minimum of inconvenience to public travel and adjoining owners, tenants and occupants.

Excessive stockpiling, as determined by the Town, of excavated materials from construction will not be permitted.

#### **15. Computation of Quantities**

For estimating quantities in which the computation of areas by geometric methods would be comparatively laborious, it is agreed that the planimeter shall be considered as an instrument of precision adapted to the measurement of such areas.

It is further agreed that the computation of volume of prisms shall be by the method of average end areas.

#### **16. Water Supply**

The Contractor shall obtain water from an approved source for all necessary operations at the site of the work, without charge therefore.

If possible, the Town will furnish the Contractor upon request with an adequate source and supply of water at no charge, however it will likely not be available at the project site. If, upon request, the Town's water supply is not available or not functioning, the Contractor will be held responsible to furnish adequate supplies at his own cost.

#### **17. Sanitary Regulations**

The Contractor shall provide adequate sanitary facilities for the use of those employed on the Work. Such facilities shall be made available when the first employees arrive on the site of the Work, shall be properly secluded from public observation, and shall be constructed and maintained during the progress of the Work in suitable numbers and at such points and in such manner as may be required.

The Contractor shall maintain the sanitary facilities in a satisfactory and sanitary condition at all times and shall enforce their use. He shall rigorously prohibit the committing of nuisances on the site of the Work, on the lands of the Owner, or on adjacent property.

#### **18. Increased or Decreased Contract Quantities**

The Town reserves the right to increase or decrease the quantity of any item of work.

Unit prices provided in the Contract Proposal will be used to determine the total added cost or credits for modifications of the work performed on a unit price basis when such work is authorized in advance by the Town. The items shall include furnishing and installing, complete in place, the specified item to the satisfaction of the Town, and in accordance with the Plans, Specifications, and Special Provisions.

No allowances will be made for loss of anticipated profits suffered or claimed by the Contractor resulting directly or indirectly from such increased or decreased quantities or from unbalanced allocation among the Contract items from any other cause.

#### **19. Contract Guarantee & Retainage**

The Contractor shall guarantee the completed job relative to workmanship and material for one year from date of project acceptance by the Town.

There will be a retainage of five (5%) percent of the value of all the items of work. The Town will hold the above retainage for a period of one (1) year from the date of satisfactory completion of the work.

## 20. Precautions under Electric Lines

The Contractor's attention is directed to the AASHTO Guide on Occupational Safety on Highway Construction Projects, Subpart N, 1926.550, relating to construction equipment clearances at overhead electric lines, which states in part "...the minimum clearance between the lines and any part of the crane or load must be at least ten feet from lines rated 50 KV or below, and greater distances for higher voltage..."

For the protection of personnel and equipment, the Contractor shall be aware of this regulation especially during paving operations using large semi-trailer vehicles.

## 21. Asphalt Cost Adjustment Clause

The Contract Price of any hot mix asphalt product will be paid under the respective items in this Contract. The price adjustment, upwards or downwards, will be made after the work has been performed, using the monthly period price for the month during which work was performed.

The price adjustment applies only to the actual virgin liquid asphalt content in the mixture placed on the job in accordance with the Standard Specifications for Highways and Bridges, Division III, Section M3.11.03.

The MassDOT Price Adjustments website (<http://www.mhd.state.ma.us/default.asp?pgid=content/fuelPrices&sid=about>) will be used in adjusting asphalt bid prices when the variance from the Base Price is 5% or more for a monthly period. The complete adjustment will be paid in all cases with no deduction of the 5% from either upward or downward adjustments.

The Base Price shall be defined as that posted in the month and year in which the Bid for this work was submitted to the Town of Arlington. The Period Price shall be defined as the time of actual asphalt installation.

The price adjustment shall be a separate payment item. It will be determined by multiplying the number of tons of hot mix asphalt placed during each monthly period times the liquid asphalt content percentage times the variance in price between Base Price and Period Price of liquid asphalt

## **VIII. SPECIFICATIONS**

### **1. Item 1: Unclassified Trench Excavation**

#### **1.1. Description**

Work under this item shall include the trench excavation for installation and removal of manholes, sewer lines, and other structures. The excavation for these items shall be made to the depth and lines indicated on the plans or established by the Engineer. This work also includes the backfilling of excavation with removed material (unless specified otherwise) and the disposal of surplus material. If the Engineer determines the material is unsuitable, the contractor shall backfill with processed gravel. Work under this item shall conform to section 100 of the MassDOT Standard Spec.

#### **1.2. Unsuitable Backfill Material**

Excavated soil that has been evaluated as unsuitable for backfill shall be removed from the site and disposed of properly. Processed gravel, as specified, shall be brought in to replace excavated soil found to be unsuitable.

1. The soil excavated from a trench shall be evaluated by experienced personnel to determine whether or not it is suitable as a backfill in accordance with this section. An excavated soil that has been evaluated as suitable for backfill shall be reused provided its moisture content has been determined to be "suitable" in accordance with standards for proper moisture content.
2. Suitable backfill material shall be free of stones larger than half the size of the compacted lift as provided for in Mass DOT Standard Specifications for Highway Bridges, construction debris, trash, frozen soil and other foreign material. Suitable materials consist (but are not limited to) the following:
  - a. Well graded gravel and sand;
  - b. Poorly graded gravel and sand;
  - c. Gravel-sand mixtures with a small amount of silt;
  - d. Gravel-sand mixtures with a small amount of silt and trace amounts of clay.

Unsuitable backfill materials consist (but are not limited to) of the following:

- a. Inorganic silts and clays;
- b. Organic silts;
- c. Organic soils including peat, humus, topsoil, swamp soils, mulch, and soils containing leaves, grass, branches, and other fibrous vegetable matter.

#### **1.3. Basis of Measurement and Payment**

Trench excavation will be measured per cubic yard of material removed (CY). Excavation for the sewer line shall be measured by length of trench, by width of trench, and by depth within trench limits documented on the contract drawings and supporting documents. Excavation for the manholes shall be measured by the diameter equal to the outside diameter of the manhole plus two feet and the depth of 1 foot below the specified bottom of manhole.

The unit bid price per cubic yard shall include all labor, materials and equipment necessary to complete the work as necessary or as directed by the Town.

## **Item 2: Crushed Stone**

### **2.1 Description**

Work under this item includes furnishing and installing the crushed stone material as a base for the sewer pipe and sewer manholes within the limits of the sewer trench.

Washed crushed stone shall be ¾ inch, conforming to MassDOT Standard Spec. M2.01.4 to M2.01.2 and shall be hard, durable and reasonably free from flat or laminated particles to furnish free draining material.

### **2.2 Method of Measurement and Basis of Payment**

Crushed Stone shall be measured cubic yard (CY) of material installed and shall be measured by the length of pipe trench, by the width of trench, by depth of stone installed as detailed on contract drawings and documents. Crushed stone for the bottom of manholes shall be measured by the diameter equal to the outside diameter of the manhole plus two feet and the depth of 1 foot below the base of the structure.

Contractor shall be responsible for the cost of all additional crushed stone above and beyond these limits unless otherwise approved by the Engineer.

Crushed Stone will be paid for at the contract unit bid price per cubic yard (CY) complete in place which shall include all labor, materials and equipment necessary to complete the work as necessary or as directed by the Town.

## **Item 3: Processed Gravel**

### **3.1 Description**

Work under this item shall include furnishing and installing the processed gravel as backfill for excavation when necessary as specified or directed by the engineer. Material used shall conform to MassDOT Standard Spec. M1.03.0.

### **3.2 Material**

Gravel shall consist of inert material that is hard, durable stone and coarse sand free from loam and clay surface coatings, be well graded and contain no stone having any dimension greater than three (3) inches.

Gravel shall conform to the following requirements:

Passing 3 inch sieve.....	100%
Passing 1 1/2 inch sieve.....	70-100%
Passing 3/4 inch sieve.....	50 - 85%
Passing No. 4 sieve.....	30 - 60%
Passing No. 200 sieve.....	0 - 10%

New bank run or processed gravel is acceptable but must meet the above requirements and be processed by mechanical means. All processed gravel shall come from an approved stockpile. The equipment producing the

processed gravel shall be of adequate size and with sufficient adjustments to produce the desired materials. The processed material shall be stockpiled in such a manner to minimize segregation of particle sizes.

### **3.3 Method of Measurement and Basis of Payment**

Processed gravel shall be measured per cubic yard (CY) of material and shall be measured by the length of pipe trench, by the width of trench, by depth of stone installed as detailed on contract drawings and documents

Contractor shall be responsible for the cost of all additional processed gravel above and beyond these limits unless otherwise approved by the Engineer.

The unit bid price per each shall include all labor, materials and equipment necessary to complete the work as necessary or as directed by the Town.

## **Item 4: Sewer Structure Removed**

### **4.1 Description**

Work under this item includes excavation and removal of an existing sewer manhole structure. The sewer structure, castings, and all associated masonry shall be completely removed and disposed.

Removal of the structure shall conform to section 220 of the MassDOT Standard Specifications.

### **4.2 Method of Measurement and Basis of Payment**

Removal of sewer structure shall be measured in place by the unit each (EA) removed and disposed.

The unit bid price per each shall include all labor, materials and equipment necessary to complete the work as necessary or as directed by the Town.

## **Item 5: Furnish and Install Sewer Manholes (0'-9')**

### **5.1 Description**

Work under this item shall consist of furnishing and installing the sewer manholes in close conformity with the lines and grades shown on the contract drawings and specifications. This includes setting the structure at level grade, and connecting existing and/or proposed sewer pipes to manholes as shown on contract drawings. Work under this item shall be in conformance with section 220 of the MassDOT Standard Specifications.

Excavation for structures will be paid for at the contract unit price per cubic yard under the item for trench excavation and will not be paid separately.

### **5.2 Method of Measurement and Basis of Payment**

Furnish and install sewer manholes shall be measured in place by the unit each (EA) furnished and installed. This item includes installing the sewer frame and covers at a level road grade and shall be in conformance with MassDOT Standard Specifications.

The unit bid price per each shall include all labor, materials and equipment necessary to complete the work as necessary or as directed by the Town.

---



## **Item 6: Furnish and Install Frame and Cover**

### **6.1 Description**

Work under this item shall consist of furnishing and installing the sewer manhole frame and cover as shown on contract drawings and specifications and shall include setting the frame and cover at level road grade and shall be in conformance with section 220 of the MassDOT Standard Specifications.

Concrete, sewer bricks, asphalt, and precast concrete collars required to install the frame and cover shall be considered incidental to the unit price.

### **6.2 Method of Measurement and Basis of Payment**

Furnish and install frame and covers shall be measured in place by the unit each (EA) furnished and installed.

The unit bid price per each shall include all labor, materials and equipment necessary to complete the work as necessary or as directed by the Town.

## **Item 7: Furnish and Install 8 Inch Sewer Pipe**

### **7.1 Description**

Work under this item shall include the furnishing and installing 8-inch diameter SDR 35 PVC sewer line to the depth and grade as indicated on the contract plans and documents. Work under this item shall be in conformance with section 230 of the MassDOT Standard Specification for Highways and Bridges.

### **7.2 Method of Measurement and Basis of Payment**

Sewer pipe installed shall be measured in place and the quantity to be paid for shall be the length of pipe installed in the field (LF).

The unit bid price per each shall include all labor, materials and equipment necessary to complete the work as necessary or as directed by the Town.

## **Item 8: Furnish and Install 6 Inch PVC Drop Inlet**

### **8.1 Description**

Work under this item shall include the furnishing and installing the 6 Inch PVC drop, and all fittings and appurtenances shown, to the depth, grade, and direction as indicated on contract plans and documents. Work under this item shall be in conformance with section 230 of the MassDOT Standard Specification for Highways and Bridges.

### **8.2 Method of Measurement and Basis of Payment**

6 Inch PVC Drop Inlet connections installed shall be measured in place by the vertical foot (VF) furnished and installed.

The unit bid price per each shall include all labor, materials and equipment necessary to complete the work as necessary or as directed by the Town.

## **Item 9: Saw cutting asphalt**

### **9.1 Description**

Work under this item shall include saw cutting existing asphalt to trench limits before excavation takes place. The saw cutting shall be done in straight lines, to the depth of existing asphalt as indicated on contract plans and documents.

### **9.2 Method of Measurement and Basis of Payment**

Saw cutting asphalt shall be measured in place by the linear foot (LF) of asphalt cut.

The unit bid price per each shall include all labor, materials and equipment necessary to complete the work as necessary or as directed by the Town.

## **Item 10: Hot Mix Asphalt**

### **10.1 Description**

Work under this item shall include the paving restoration of the sewer trench as detailed on contract drawings and documents. Work under this item shall be in conformance with Section 400 of the MassDOT Standard Specification for Highways and Bridges.

The finished surface of the mixture, after compaction, shall be true to the established line and grade of the existing pavement.

**THE CONTRACTOR SHALL NOT LEAVE EXCAVATED AREAS UNPAVED OVER WEEKENDS UNLESS THROUGH WRITTEN APPROVAL OF THE ENGINEER.**

### **10.2 Maintenance Period of roadway surface**

The Contractor shall be responsible to maintain trenches and patching at his expense for a period of one year after the backfilling and patching of the trench and shall promptly refill and repair areas, which have settled or are otherwise unsatisfactory for pedestrian and vehicular traffic.

The Contractor shall be responsible and hold the Town harmless for any damages sustained to persons or property as a result of any accident that may occur on account of the defective condition of the street or sidewalk surface.

Final payment or acceptance by the Town of the completed contract shall have no effect on the Contractor's obligation as indicated in the above paragraphs.

### **10.3 Method of Measurement and Basis of Payment**

Paving will be measured per ton (TON) of material in place. To be determined by actual length of trench, a 5 foot width, and a depth of 4 inches. Contractor will supply copies of paving slips to the engineer from asphalt plant.

Contractor shall be responsible for all additional paving above and beyond these limits unless otherwise approved by the Engineer.

The unit bid price per each shall include all labor, materials and equipment necessary to complete the work as necessary or as directed by the Town.

## **Item 11: Loam Borrow**

### **11.1 Description**

Work under this item shall include restoring areas disturbed due to excavation and other construction activities with a minimum of 6 inches loam borrow. Contractor is responsible for restoring disturbed area to original grade and a condition equal to, or better than the original. Work under this item shall be in conformance with Section 751 of the MassDOT Standard Specification for Highways and Bridges.

### **11.2 Method of Measurement and Basis of Payment**

Loam Borrow will be paid for at the contract unit price per Cubic Yard (CY), complete in place.

The unit bid price per each shall include all labor, materials and equipment necessary to complete the work as necessary or as directed by the Town.

## **Item 12: Seeding and Rolling**

### **12.1 Description**

Work under this item shall include restoring areas disturbed due to excavation and other construction activities with an approved seed mixture rolled into the top soil. Contractor is responsible for restoring disturbed area to original grade and a condition equal to, or better than the original. Work under this item shall be in conformance with Section 751 of the MassDOT Standard Specification for Highways and Bridges.

### **12.2 Method of Measurement and Basis of Payment**

Seeding and Rolling will be paid for at the contract unit price per square yard (SY), complete in place.

At the time the final estimate is being prepared, the seeded areas will again be inspected by the Engineer and if a satisfactory stand of grass has been established, the satisfactory area grass will be included for payment. If the seeded area is not satisfactory to the Engineer, the Contractor will re-seed and roll the area.

The unit bid price per each shall include all labor, materials and equipment necessary to complete the work as necessary or as directed by the Town.

CAUTION: This email originated from outside of the Town of Arlington's email system. Do not click links or open attachments unless you recognize the REAL sender (whose email address in the From: line in "< >" brackets) and you know the content is safe.

To view and print Weekly Payroll & Statement of Compliance Forms, click on [www.mass.gov/dols/pw](http://www.mass.gov/dols/pw).

PLEASE NOTE: The attached Prevailing Wage Schedule is valid for 90 days. An Awarding Authority should re-request an up to date Prevailing Wage Schedule if it has NOT opened bids or selected a contractor within 90 days of the issuance date of the attached prevailing wage schedule.

\*For MULTI-YEAR projects bid on or after 8/8/08, Awarding Authorities must request an Annual Update to this Prevailing Wage Schedule each year for the duration of the project, no later than two weeks before the anniversary date of the execution of the general contract. Annual updates are not required for projects that last LESS THAN ONE YEAR.

\*For CM AT RISK projects (bid pursuant to GL c.149A), Awarding Authorities must request a Prevailing Wage Schedule NOT sooner than 90-days before the earlier of: (a) the execution date of the GMP Amendment, or (b) the bid for the first construction scope of work.

\*For MULTI-YEAR CM AT RISK projects, Awarding Authorities must request an Annual Update to this Prevailing Wage Schedule each year for the duration of the project, no later than two weeks before the anniversary date, which is the earlier of: (a) the execution date of the GMP Amendment, or (b) the execution date of the first amendment to procure construction scopes of work.

Apprentice wages (expressed as dollar figures) and the required benefits are listed on the Prevailing Wage Schedule. For further details, please see opinion letter PW-2010-03-03.16.10 (dated March 18, 2010) at [www.mass.gov/dols/pw](http://www.mass.gov/dols/pw).

Request Prevailing Wage Rates online at: [www.mass.gov/dols/pw](http://www.mass.gov/dols/pw).

THIS IS A SYSTEM-GENERATED EMAIL. PLEASE DO NOT REPLY TO THIS EMAIL. TO CONTACT DLS REGARDING PREVAILING WAGE MATTERS, CALL 617-626-6953.

=====

APPROVAL/DENIAL COMMENTS



**THE COMMONWEALTH OF MASSACHUSETTS  
EXECUTIVE OFFICE OF LABOR AND WORKFORCE DEVELOPMENT  
DEPARTMENT OF LABOR STANDARDS**

**Prevailing Wage Rates**

**As determined by the Director under the provisions of the  
Massachusetts General Laws, Chapter 149, Sections 26 to 27H**

CHARLES D. BAKER  
Governor

KARYN E. POLITO  
Lt. Governor

ROSALIN ACOSTA  
Secretary  
MICHAEL FLANAGAN  
Director

**Awarding Authority:** Town of Arlington  
**Contract Number:** 21-18 **City/Town:** ARLINGTON  
**Description of Work:** Fessenden Road Sewer Construction - Installation of sewer main to include excavation, site work, pipe & manhole installation, paving and landscaping.  
**Job Location:** Fessenden Road

Information about Prevailing Wage Schedules for Awarding Authorities and Contractors

- This wage schedule applies only to the specific project referenced at the top of this page and uniquely identified by the “Wage Request Number” on all pages of this schedule.
- An Awarding Authority must request an updated wage schedule from the Department of Labor Standards (“DLS”) if it has not opened bids or selected a contractor within 90 days of the date of issuance of the wage schedule. For CM AT RISK projects (bid pursuant to G.L. c.149A), the earlier of: (a) the execution date of the GMP Amendment, or (b) the bid for the first construction scope of work must be within 90-days of the wage schedule issuance date.
- The wage schedule shall be incorporated in any advertisement or call for bids for the project as required by M.G.L. c. 149, § 27. The wage schedule shall be made a part of the contract awarded for the project. The wage schedule must be posted in a conspicuous place at the work site for the life of the project in accordance with M.G.L. c. 149 § 27. The wages listed on the wage schedule must be paid to employees performing construction work on the project whether they are employed by the prime contractor, a filed sub-bidder, or any sub-contractor.
- All apprentices working on the project are required to be registered with the Massachusetts Department of Labor Standards, Division of Apprentice Standards (DLS/DAS). Apprentice must keep his/her apprentice identification card on his/her person during all work hours on the project. An apprentice registered with DAS may be paid the lower apprentice wage rate at the applicable step as provided on the prevailing wage schedule. **Any apprentice not registered with DLS/DAS regardless of whether or not they are registered with any other federal, state, local, or private agency must be paid the journeyworker's rate for the trade.**
- The wage rates will remain in effect for the duration of the project, except in the case of multi-year public construction projects. For construction projects lasting longer than one year, awarding authorities must request an updated wage schedule. Awarding authorities are required to request these updates no later than two weeks before the anniversary of the date the contract was executed by the awarding authority and the general contractor. For multi-year CM AT RISK projects, awarding authority must request an annual update no later than two weeks before the anniversary date, determined as the earlier of: (a) the execution date of the GMP Amendment, or (b) the execution date of the first amendment to permit procurement of construction services. Contractors are required to obtain the wage schedules from awarding authorities, and to pay no less than these rates to covered workers. The annual update requirement is not applicable to 27F “rental of equipment” contracts.
- Every contractor or subcontractor which performs construction work on the project is required to submit weekly payroll reports and a Statement of Compliance directly to the awarding authority by mail or email and keep them on file for three years. Each weekly payroll report must contain: the employee’s name, address, occupational classification, hours worked, and wages paid. Do not submit weekly payroll reports to DLS. A sample of a payroll reporting form may be obtained at <http://www.mass.gov/dols/pw>.
- Contractors with questions about the wage rates or classifications included on the wage schedule have an affirmative obligation to inquire with DLS at (617) 626-6953.
- Employees not receiving the prevailing wage rate set forth on the wage schedule may report the violation to the Fair Labor Division of the office of the Attorney General at (617) 727-3465.
- Failure of a contractor or subcontractor to pay the prevailing wage rates listed on the wage schedule to all employees who perform construction work on the project is a violation of the law and subjects the contractor or subcontractor to civil and criminal penalties.

Classification	Effective Date	Base Wage	Health	Pension	Supplemental Unemployment	Total Rate
<b>Construction</b>						
(2 AXLE) DRIVER - EQUIPMENT <i>TEAMSTERS JOINT COUNCIL NO. 10 ZONE A</i>	06/01/2021	\$37.05	\$12.91	\$14.82	\$0.00	\$64.78
	08/01/2021	\$37.05	\$13.41	\$14.82	\$0.00	\$65.28
	12/01/2021	\$37.05	\$13.41	\$16.01	\$0.00	\$66.47
(3 AXLE) DRIVER - EQUIPMENT <i>TEAMSTERS JOINT COUNCIL NO. 10 ZONE A</i>	06/01/2021	\$37.12	\$12.91	\$14.82	\$0.00	\$64.85
	08/01/2021	\$37.12	\$13.41	\$14.82	\$0.00	\$65.35
	12/01/2021	\$37.12	\$13.41	\$16.01	\$0.00	\$66.54
(4 & 5 AXLE) DRIVER - EQUIPMENT <i>TEAMSTERS JOINT COUNCIL NO. 10 ZONE A</i>	06/01/2021	\$37.24	\$12.91	\$14.82	\$0.00	\$64.97
	08/01/2021	\$37.24	\$13.41	\$14.82	\$0.00	\$65.47
	12/01/2021	\$37.24	\$13.41	\$16.01	\$0.00	\$66.66
ADS/SUBMERSIBLE PILOT <i>PILE DRIVER LOCAL 56 (ZONE 1)</i>	08/01/2020	\$103.05	\$9.40	\$23.12	\$0.00	\$135.57
For apprentice rates see "Apprentice- PILE DRIVER"						
AIR TRACK OPERATOR <i>LABORERS - ZONE 1</i>	06/01/2021	\$41.42	\$8.60	\$17.57	\$0.00	\$67.59
	12/01/2021	\$42.43	\$8.60	\$17.57	\$0.00	\$68.60
	06/01/2022	\$43.43	\$8.60	\$17.57	\$0.00	\$69.60
	12/01/2022	\$44.43	\$8.60	\$17.57	\$0.00	\$70.60
	06/01/2023	\$45.43	\$8.60	\$17.57	\$0.00	\$71.60
	12/01/2023	\$46.68	\$8.60	\$17.57	\$0.00	\$72.85
For apprentice rates see "Apprentice- LABORER"						
AIR TRACK OPERATOR (HEAVY & HIGHWAY) <i>LABORERS - ZONE 1 (HEAVY &amp; HIGHWAY)</i>	06/01/2021	\$41.42	\$8.60	\$17.57	\$0.00	\$67.59
	12/01/2021	\$42.43	\$8.60	\$17.57	\$0.00	\$68.60
For apprentice rates see "Apprentice- LABORER (Heavy and Highway)"						
ASBESTOS REMOVER - PIPE / MECH. EQUIPT. <i>HEAT &amp; FROST INSULATORS LOCAL 6 (BOSTON)</i>	12/01/2020	\$38.10	\$12.80	\$9.45	\$0.00	\$60.35
ASPHALT RAKER <i>LABORERS - ZONE 1</i>	06/01/2021	\$40.92	\$8.60	\$17.57	\$0.00	\$67.09
	12/01/2021	\$41.93	\$8.60	\$17.57	\$0.00	\$68.10
	06/01/2022	\$42.93	\$8.60	\$17.57	\$0.00	\$69.10
	12/01/2022	\$43.93	\$8.60	\$17.57	\$0.00	\$70.10
	06/01/2023	\$44.93	\$8.60	\$17.57	\$0.00	\$71.10
	12/01/2023	\$46.18	\$8.60	\$17.57	\$0.00	\$72.35
For apprentice rates see "Apprentice- LABORER"						
ASPHALT RAKER (HEAVY & HIGHWAY) <i>LABORERS - ZONE 1 (HEAVY &amp; HIGHWAY)</i>	06/01/2021	\$40.92	\$8.60	\$17.57	\$0.00	\$67.09
	12/01/2021	\$41.93	\$8.60	\$17.57	\$0.00	\$68.10
For apprentice rates see "Apprentice- LABORER (Heavy and Highway)"						
ASPHALT/CONCRETE/CRUSHER PLANT-ON SITE <i>OPERATING ENGINEERS LOCAL 4</i>	06/01/2021	\$50.73	\$13.75	\$15.80	\$0.00	\$80.28
	12/01/2021	\$51.88	\$13.75	\$15.80	\$0.00	\$81.43
For apprentice rates see "Apprentice- OPERATING ENGINEERS"						
BACKHOE/FRONT-END LOADER <i>OPERATING ENGINEERS LOCAL 4</i>	06/01/2021	\$50.73	\$13.75	\$15.80	\$0.00	\$80.28
	12/01/2021	\$51.88	\$13.75	\$15.80	\$0.00	\$81.43
For apprentice rates see "Apprentice- OPERATING ENGINEERS"						
BARCO-TYPE JUMPING TAMPER <i>LABORERS - ZONE 1</i>	06/01/2021	\$40.92	\$8.60	\$17.57	\$0.00	\$67.09
	12/01/2021	\$41.93	\$8.60	\$17.57	\$0.00	\$68.10
	06/01/2022	\$42.93	\$8.60	\$17.57	\$0.00	\$69.10
	12/01/2022	\$43.93	\$8.60	\$17.57	\$0.00	\$70.10
	06/01/2023	\$44.93	\$8.60	\$17.57	\$0.00	\$71.10
	12/01/2023	\$46.18	\$8.60	\$17.57	\$0.00	\$72.35

Classification	Effective Date	Base Wage	Health	Pension	Supplemental Unemployment	Total Rate
For apprentice rates see "Apprentice- LABORER"						
BLOCK PAVER, RAMMER / CURB SETTER <i>LABORERS - ZONE 1</i>	06/01/2021	\$41.42	\$8.60	\$17.57	\$0.00	\$67.59
	12/01/2021	\$42.43	\$8.60	\$17.57	\$0.00	\$68.60
	06/01/2022	\$43.43	\$8.60	\$17.57	\$0.00	\$69.60
	12/01/2022	\$44.43	\$8.60	\$17.57	\$0.00	\$70.60
	06/01/2023	\$45.43	\$8.60	\$17.57	\$0.00	\$71.60
	12/01/2023	\$46.68	\$8.60	\$17.57	\$0.00	\$72.85
For apprentice rates see "Apprentice- LABORER"						
BLOCK PAVER, RAMMER / CURB SETTER (HEAVY & HIGHWAY) <i>LABORERS - ZONE 1 (HEAVY &amp; HIGHWAY)</i>	06/01/2021	\$41.42	\$8.60	\$17.57	\$0.00	\$67.59
	12/01/2021	\$42.43	\$8.60	\$17.57	\$0.00	\$68.60
For apprentice rates see "Apprentice- LABORER (Heavy and Highway)"						
BOILER MAKER <i>BOILERMAKERS LOCAL 29</i>	01/01/2020	\$46.10	\$7.07	\$17.98	\$0.00	\$71.15

**Apprentice - BOILERMAKER - Local 29**

**Effective Date - 01/01/2020**

Step	percent	Apprentice Base Wage	Health	Pension	Supplemental Unemployment	Total Rate
1	65	\$29.97	\$7.07	\$11.69	\$0.00	\$48.73
2	65	\$29.97	\$7.07	\$11.69	\$0.00	\$48.73
3	70	\$32.27	\$7.07	\$12.59	\$0.00	\$51.93
4	75	\$34.58	\$7.07	\$13.49	\$0.00	\$55.14
5	80	\$36.88	\$7.07	\$14.38	\$0.00	\$58.33
6	85	\$39.19	\$7.07	\$15.29	\$0.00	\$61.55
7	90	\$41.49	\$7.07	\$16.18	\$0.00	\$64.74
8	95	\$43.80	\$7.07	\$17.09	\$0.00	\$67.96

**Notes:**

**Apprentice to Journeyworker Ratio:1:4**

BRICK/STONE/ARTIFICIAL MASONRY (INCL. MASONRY WATERPROOFING) <i>BRICKLAYERS LOCAL 3 (BOSTON)</i>	02/01/2021	\$55.75	\$11.39	\$22.09	\$0.00	\$89.23
	08/01/2021	\$57.15	\$11.39	\$22.25	\$0.00	\$90.79
	02/01/2022	\$57.74	\$11.39	\$22.25	\$0.00	\$91.38

**Classification**

**Effective Date   Base Wage   Health   Pension   Supplemental Unemployment   Total Rate**

**Apprentice - BRICK/PLASTER/CEMENT MASON - Local 3 Boston**

**Effective Date - 02/01/2021**

Step	percent	Apprentice Base Wage	Health	Pension	Supplemental Unemployment	Total Rate
1	50	\$27.88	\$11.39	\$22.09	\$0.00	\$61.36
2	60	\$33.45	\$11.39	\$22.09	\$0.00	\$66.93
3	70	\$39.03	\$11.39	\$22.09	\$0.00	\$72.51
4	80	\$44.60	\$10.75	\$22.09	\$0.00	\$77.44
5	90	\$50.18	\$10.75	\$22.09	\$0.00	\$83.02

**Effective Date - 08/01/2021**

Step	percent	Apprentice Base Wage	Health	Pension	Supplemental Unemployment	Total Rate
1	50	\$28.58	\$11.39	\$22.25	\$0.00	\$62.22
2	60	\$34.29	\$11.39	\$22.25	\$0.00	\$67.93
3	70	\$40.01	\$11.39	\$22.25	\$0.00	\$73.65
4	80	\$45.72	\$10.75	\$22.25	\$0.00	\$78.72
5	90	\$51.44	\$10.75	\$22.25	\$0.00	\$84.44

**Notes:**

**Apprentice to Journeyworker Ratio:1:5**

<b>BULLDOZER/GRADER/SCRAPER</b> <i>OPERATING ENGINEERS LOCAL 4</i>	06/01/2021	\$50.19	\$13.75	\$15.80	\$0.00	\$79.74
	12/01/2021	\$51.33	\$13.75	\$15.80	\$0.00	\$80.88
For apprentice rates see "Apprentice- OPERATING ENGINEERS"						
<b>CAISSON &amp; UNDERPINNING BOTTOM MAN</b> <i>LABORERS - FOUNDATION AND MARINE</i>	06/01/2021	\$41.82	\$8.60	\$17.72	\$0.00	\$68.14
	12/01/2021	\$42.83	\$8.60	\$17.72	\$0.00	\$69.15
For apprentice rates see "Apprentice- LABORER"						
<b>CAISSON &amp; UNDERPINNING LABORER</b> <i>LABORERS - FOUNDATION AND MARINE</i>	06/01/2021	\$40.67	\$8.60	\$17.72	\$0.00	\$66.99
	12/01/2021	\$41.68	\$8.60	\$17.72	\$0.00	\$68.00
For apprentice rates see "Apprentice- LABORER"						
<b>CAISSON &amp; UNDERPINNING TOP MAN</b> <i>LABORERS - FOUNDATION AND MARINE</i>	06/01/2021	\$40.67	\$8.60	\$17.72	\$0.00	\$66.99
	12/01/2021	\$41.68	\$8.60	\$17.72	\$0.00	\$68.00
For apprentice rates see "Apprentice- LABORER"						
<b>CARBIDE CORE DRILL OPERATOR</b> <i>LABORERS - ZONE 1</i>	06/01/2021	\$40.92	\$8.60	\$17.57	\$0.00	\$67.09
	12/01/2021	\$41.93	\$8.60	\$17.57	\$0.00	\$68.10
	06/01/2022	\$42.93	\$8.60	\$17.57	\$0.00	\$69.10
	12/01/2022	\$43.93	\$8.60	\$17.57	\$0.00	\$70.10
	06/01/2023	\$44.93	\$8.60	\$17.57	\$0.00	\$71.10
	12/01/2023	\$46.18	\$8.60	\$17.57	\$0.00	\$72.35
For apprentice rates see "Apprentice- LABORER"						
<b>CARPENTER</b> <i>CARPENTERS -ZONE 2 (Eastern Massachusetts)</i>	03/01/2021	\$43.54	\$9.40	\$18.95	\$0.00	\$71.89
	09/01/2021	\$44.19	\$9.40	\$18.95	\$0.00	\$72.54
	03/01/2022	\$44.79	\$9.40	\$18.95	\$0.00	\$73.14
	09/01/2022	\$45.44	\$9.40	\$18.95	\$0.00	\$73.79
	03/01/2023	\$46.04	\$9.40	\$18.95	\$0.00	\$74.39



**Classification**

**Effective Date    Base Wage    Health    Pension    Supplemental Unemployment    Total Rate**

**Apprentice - CARPENTER - Zone 2 Eastern MA**

**Effective Date - 03/01/2021**

Step	percent	Apprentice Base Wage	Health	Pension	Supplemental Unemployment	Total Rate
1	50	\$21.77	\$9.40	\$1.73	\$0.00	\$32.90
2	60	\$26.12	\$9.40	\$1.73	\$0.00	\$37.25
3	70	\$30.48	\$9.40	\$13.76	\$0.00	\$53.64
4	75	\$32.66	\$9.40	\$13.76	\$0.00	\$55.82
5	80	\$34.83	\$9.40	\$15.49	\$0.00	\$59.72
6	80	\$34.83	\$9.40	\$15.49	\$0.00	\$59.72
7	90	\$39.19	\$9.40	\$17.22	\$0.00	\$65.81
8	90	\$39.19	\$9.40	\$17.22	\$0.00	\$65.81

**Effective Date - 09/01/2021**

Step	percent	Apprentice Base Wage	Health	Pension	Supplemental Unemployment	Total Rate
1	50	\$22.10	\$9.40	\$1.73	\$0.00	\$33.23
2	60	\$26.51	\$9.40	\$1.73	\$0.00	\$37.64
3	70	\$30.93	\$9.40	\$13.76	\$0.00	\$54.09
4	75	\$33.14	\$9.40	\$13.76	\$0.00	\$56.30
5	80	\$35.35	\$9.40	\$15.49	\$0.00	\$60.24
6	80	\$35.35	\$9.40	\$15.49	\$0.00	\$60.24
7	90	\$39.77	\$9.40	\$17.22	\$0.00	\$66.39
8	90	\$39.77	\$9.40	\$17.22	\$0.00	\$66.39

**Notes:**

% Indentured After 10/1/17; 45/45/55/55/70/70/80/80  
 Step 1&2 \$30.72/ 3&4 \$36.75/ 5&6 \$55.37/ 7&8 \$61.45

**Apprentice to Journeyworker Ratio:1:5**

CARPENTER WOOD FRAME	04/01/2021	\$23.16	\$7.21	\$4.80	\$0.00	\$35.17
CARPENTERS-ZONE 3 (Wood Frame)	04/01/2022	\$23.66	\$7.21	\$4.80	\$0.00	\$35.67
	04/01/2023	\$24.16	\$7.21	\$4.80	\$0.00	\$36.17

All Aspects of New Wood Frame Work

**Classification**

**Effective Date   Base Wage   Health   Pension   Supplemental Unemployment   Total Rate**

**Apprentice - CARPENTER (Wood Frame) - Zone 3**

**Effective Date - 04/01/2021**

Step	percent	Apprentice Base Wage	Health	Pension	Supplemental Unemployment	Total Rate
1	60	\$13.90	\$7.21	\$0.00	\$0.00	\$21.11
2	60	\$13.90	\$7.21	\$0.00	\$0.00	\$21.11
3	65	\$15.05	\$7.21	\$0.00	\$0.00	\$22.26
4	70	\$16.21	\$7.21	\$0.00	\$0.00	\$23.42
5	75	\$17.37	\$7.21	\$3.80	\$0.00	\$28.38
6	80	\$18.53	\$7.21	\$3.80	\$0.00	\$29.54
7	85	\$19.69	\$7.21	\$3.80	\$0.00	\$30.70
8	90	\$20.84	\$7.21	\$3.80	\$0.00	\$31.85

**Effective Date - 04/01/2022**

Step	percent	Apprentice Base Wage	Health	Pension	Supplemental Unemployment	Total Rate
1	60	\$14.20	\$7.21	\$0.00	\$0.00	\$21.41
2	60	\$14.20	\$7.21	\$0.00	\$0.00	\$21.41
3	65	\$15.38	\$7.21	\$0.00	\$0.00	\$22.59
4	70	\$16.56	\$7.21	\$0.00	\$0.00	\$23.77
5	75	\$17.75	\$7.21	\$3.80	\$0.00	\$28.76
6	80	\$18.93	\$7.21	\$3.80	\$0.00	\$29.94
7	85	\$20.11	\$7.21	\$3.80	\$0.00	\$31.12
8	90	\$21.29	\$7.21	\$3.80	\$0.00	\$32.30

**Notes:**

% Indentured After 10/1/17; 45/45/55/55/70/70/80/80  
 Step 1&2 \$17.63/ 3&4 \$19.95/ 5&6 \$27.22/ 7&8 \$29.54

**Apprentice to Journeyworker Ratio:1:5**

CEMENT MASONRY/PLASTERING BRICKLAYERS LOCAL 3 (BOSTON)	01/01/2020	\$49.07	\$12.75	\$22.41	\$0.62	\$84.85
---	------------	---------	---------	---------	--------	---------

**Apprentice - CEMENT MASONRY/PLASTERING - Eastern Mass (Boston)**

**Effective Date - 01/01/2020**

Step	percent	Apprentice Base Wage	Health	Pension	Supplemental Unemployment	Total Rate
1	50	\$24.54	\$12.75	\$15.41	\$0.00	\$52.70
2	60	\$29.44	\$12.75	\$17.41	\$0.62	\$60.22
3	65	\$31.90	\$12.75	\$18.41	\$0.62	\$63.68
4	70	\$34.35	\$12.75	\$19.41	\$0.62	\$67.13
5	75	\$36.80	\$12.75	\$20.41	\$0.62	\$70.58
6	80	\$39.26	\$12.75	\$21.41	\$0.62	\$74.04
7	90	\$44.16	\$12.75	\$22.41	\$0.62	\$79.94

**Notes:**

Steps 3,4 are 500 hrs. All other steps are 1,000 hrs.

**Apprentice to Journeyworker Ratio:1:3**

Classification	Effective Date	Base Wage	Health	Pension	Supplemental Unemployment	Total Rate
CHAIN SAW OPERATOR <i>LABORERS - ZONE 1</i>	06/01/2021	\$40.92	\$8.60	\$17.57	\$0.00	\$67.09
	12/01/2021	\$41.93	\$8.60	\$17.57	\$0.00	\$68.10
	06/01/2022	\$42.93	\$8.60	\$17.57	\$0.00	\$69.10
	12/01/2022	\$43.93	\$8.60	\$17.57	\$0.00	\$70.10
	06/01/2023	\$44.93	\$8.60	\$17.57	\$0.00	\$71.10
	12/01/2023	\$46.18	\$8.60	\$17.57	\$0.00	\$72.35
For apprentice rates see "Apprentice- LABORER"						
CLAM SHELLS/SLURRY BUCKETS/HEADING MACHINES <i>OPERATING ENGINEERS LOCAL 4</i>	06/01/2021	\$51.73	\$13.75	\$15.80	\$0.00	\$81.28
	12/01/2021	\$52.88	\$13.75	\$15.80	\$0.00	\$82.43
For apprentice rates see "Apprentice- OPERATING ENGINEERS"						
COMPRESSOR OPERATOR <i>OPERATING ENGINEERS LOCAL 4</i>	06/01/2021	\$33.40	\$13.75	\$15.80	\$0.00	\$62.95
	12/01/2021	\$34.19	\$13.75	\$15.80	\$0.00	\$63.74
For apprentice rates see "Apprentice- OPERATING ENGINEERS"						
DELEADER (BRIDGE) <i>PAINTERS LOCAL 35 - ZONE 2</i>	01/01/2021	\$52.06	\$8.25	\$22.75	\$0.00	\$83.06

**Apprentice - PAINTER Local 35 - BRIDGES/TANKS**

**Effective Date - 01/01/2021**

Step	percent	Apprentice Base Wage	Health	Pension	Supplemental Unemployment	Total Rate
1	50	\$26.03	\$8.25	\$0.00	\$0.00	\$34.28
2	55	\$28.63	\$8.25	\$6.16	\$0.00	\$43.04
3	60	\$31.24	\$8.25	\$6.72	\$0.00	\$46.21
4	65	\$33.84	\$8.25	\$7.28	\$0.00	\$49.37
5	70	\$36.44	\$8.25	\$19.39	\$0.00	\$64.08
6	75	\$39.05	\$8.25	\$19.95	\$0.00	\$67.25
7	80	\$41.65	\$8.25	\$20.51	\$0.00	\$70.41
8	90	\$46.85	\$8.25	\$21.63	\$0.00	\$76.73

**Notes:**

Steps are 750 hrs.

**Apprentice to Journeyworker Ratio:1:1**

DEMO: ADZEMAN <i>LABORERS - ZONE 1</i>	06/01/2021	\$40.82	\$8.60	\$17.57	\$0.00	\$66.99
	12/01/2021	\$41.83	\$8.60	\$17.57	\$0.00	\$68.00
	06/01/2022	\$42.83	\$8.60	\$17.57	\$0.00	\$69.00
	12/01/2022	\$43.83	\$8.60	\$17.57	\$0.00	\$70.00
	06/01/2023	\$44.83	\$8.60	\$17.57	\$0.00	\$71.00
	12/01/2023	\$46.08	\$8.60	\$17.57	\$0.00	\$72.25
For apprentice rates see "Apprentice- LABORER"						
DEMO: BACKHOE/LOADER/HAMMER OPERATOR <i>LABORERS - ZONE 1</i>	06/01/2021	\$41.82	\$8.60	\$17.57	\$0.00	\$67.99
	12/01/2021	\$42.83	\$8.60	\$17.57	\$0.00	\$69.00
	06/01/2022	\$43.83	\$8.60	\$17.57	\$0.00	\$70.00
	12/01/2022	\$44.83	\$8.60	\$17.57	\$0.00	\$71.00
	06/01/2023	\$45.83	\$8.60	\$17.57	\$0.00	\$72.00
	12/01/2023	\$47.08	\$8.60	\$17.57	\$0.00	\$73.25
For apprentice rates see "Apprentice- LABORER"						

<b>Classification</b>	<b>Effective Date</b>	<b>Base Wage</b>	<b>Health</b>	<b>Pension</b>	<b>Supplemental Unemployment</b>	<b>Total Rate</b>	
DEMO: BURNERS <i>LABORERS - ZONE 1</i>	06/01/2021	\$41.57	\$8.60	\$17.57	\$0.00	\$67.74	
	12/01/2021	\$42.58	\$8.60	\$17.57	\$0.00	\$68.75	
	06/01/2022	\$43.58	\$8.60	\$17.57	\$0.00	\$69.75	
	12/01/2022	\$44.58	\$8.60	\$17.57	\$0.00	\$70.75	
	06/01/2023	\$45.58	\$8.60	\$17.57	\$0.00	\$71.75	
	12/01/2023	\$46.83	\$8.60	\$17.57	\$0.00	\$73.00	
For apprentice rates see "Apprentice- LABORER"							
DEMO: CONCRETE CUTTER/SAWYER <i>LABORERS - ZONE 1</i>	06/01/2021	\$41.82	\$8.60	\$17.57	\$0.00	\$67.99	
	12/01/2021	\$42.83	\$8.60	\$17.57	\$0.00	\$69.00	
	06/01/2022	\$43.83	\$8.60	\$17.57	\$0.00	\$70.00	
	12/01/2022	\$44.83	\$8.60	\$17.57	\$0.00	\$71.00	
	06/01/2023	\$45.83	\$8.60	\$17.57	\$0.00	\$72.00	
	12/01/2023	\$47.08	\$8.60	\$17.57	\$0.00	\$73.25	
For apprentice rates see "Apprentice- LABORER"							
DEMO: JACKHAMMER OPERATOR <i>LABORERS - ZONE 1</i>	06/01/2021	\$41.57	\$8.60	\$17.57	\$0.00	\$67.74	
	12/01/2021	\$42.58	\$8.60	\$17.57	\$0.00	\$68.75	
	06/01/2022	\$43.58	\$8.60	\$17.57	\$0.00	\$69.75	
	12/01/2022	\$44.58	\$8.60	\$17.57	\$0.00	\$70.75	
	06/01/2023	\$45.58	\$8.60	\$17.57	\$0.00	\$71.75	
	12/01/2023	\$46.83	\$8.60	\$17.57	\$0.00	\$73.00	
For apprentice rates see "Apprentice- LABORER"							
DEMO: WRECKING LABORER <i>LABORERS - ZONE 1</i>	06/01/2021	\$40.82	\$8.60	\$17.57	\$0.00	\$66.99	
	12/01/2021	\$41.83	\$8.60	\$17.57	\$0.00	\$68.00	
	06/01/2022	\$42.83	\$8.60	\$17.57	\$0.00	\$69.00	
	12/01/2022	\$43.83	\$8.60	\$17.57	\$0.00	\$70.00	
	06/01/2023	\$44.83	\$8.60	\$17.57	\$0.00	\$71.00	
	12/01/2023	\$46.08	\$8.60	\$17.57	\$0.00	\$72.25	
For apprentice rates see "Apprentice- LABORER"							
DIRECTIONAL DRILL MACHINE OPERATOR <i>OPERATING ENGINEERS LOCAL 4</i>	06/01/2021	\$50.19	\$13.75	\$15.80	\$0.00	\$79.74	
	12/01/2021	\$51.33	\$13.75	\$15.80	\$0.00	\$80.88	
	For apprentice rates see "Apprentice- OPERATING ENGINEERS"						
	DIVER						
	<i>PILE DRIVER LOCAL 56 (ZONE 1)</i>						
For apprentice rates see "Apprentice- PILE DRIVER"							
DIVER TENDER <i>PILE DRIVER LOCAL 56 (ZONE 1)</i>	08/01/2020	\$49.07	\$9.40	\$23.12	\$0.00	\$81.59	
	For apprentice rates see "Apprentice- PILE DRIVER"						
DIVER TENDER (EFFLUENT) <i>PILE DRIVER LOCAL 56 (ZONE 1)</i>	08/01/2020	\$73.60	\$9.40	\$23.12	\$0.00	\$106.12	
	For apprentice rates see "Apprentice- PILE DRIVER"						
DIVER/SLURRY (EFFLUENT) <i>PILE DRIVER LOCAL 56 (ZONE 1)</i>	08/01/2020	\$103.05	\$9.40	\$23.12	\$0.00	\$135.57	
	For apprentice rates see "Apprentice- PILE DRIVER"						
DRAWBRIDGE OPERATOR (Construction) <i>DRAWBRIDGE - SEIU LOCAL 888</i>	07/01/2020	\$26.77	\$6.67	\$3.93	\$0.16	\$37.53	

Classification	Effective Date	Base Wage	Health	Pension	Supplemental Unemployment	Total Rate
ELECTRICIAN <i>ELECTRICIANS LOCAL 103</i>	03/01/2021	\$55.41	\$13.00	\$20.01	\$0.00	\$88.42
	09/01/2021	\$56.84	\$13.00	\$20.06	\$0.00	\$89.90
	03/01/2022	\$58.04	\$13.00	\$20.09	\$0.00	\$91.13
	09/01/2022	\$59.48	\$13.00	\$20.13	\$0.00	\$92.61
	03/01/2023	\$60.67	\$13.00	\$20.17	\$0.00	\$93.84

**Apprentice - *ELECTRICIAN - Local 103***

**Effective Date - 03/01/2021**

Step	percent	Apprentice Base Wage	Health	Pension	Supplemental Unemployment	Total Rate
1	40	\$22.16	\$13.00	\$0.66	\$0.00	\$35.82
2	40	\$22.16	\$13.00	\$0.66	\$0.00	\$35.82
3	45	\$24.93	\$13.00	\$15.13	\$0.00	\$53.06
4	45	\$24.93	\$13.00	\$15.13	\$0.00	\$53.06
5	50	\$27.71	\$13.00	\$15.57	\$0.00	\$56.28
6	55	\$30.48	\$13.00	\$16.01	\$0.00	\$59.49
7	60	\$33.25	\$13.00	\$16.46	\$0.00	\$62.71
8	65	\$36.02	\$13.00	\$16.90	\$0.00	\$65.92
9	70	\$38.79	\$13.00	\$17.34	\$0.00	\$69.13
10	75	\$41.56	\$13.00	\$17.80	\$0.00	\$72.36

**Effective Date - 09/01/2021**

Step	percent	Apprentice Base Wage	Health	Pension	Supplemental Unemployment	Total Rate
1	40	\$22.74	\$13.00	\$0.68	\$0.00	\$36.42
2	40	\$22.74	\$13.00	\$0.68	\$0.00	\$36.42
3	45	\$25.58	\$13.00	\$15.15	\$0.00	\$53.73
4	45	\$25.58	\$13.00	\$15.15	\$0.00	\$53.73
5	50	\$28.42	\$13.00	\$15.59	\$0.00	\$57.01
6	55	\$31.26	\$13.00	\$16.04	\$0.00	\$60.30
7	60	\$34.10	\$13.00	\$16.48	\$0.00	\$63.58
8	65	\$36.95	\$13.00	\$16.93	\$0.00	\$66.88
9	70	\$39.79	\$13.00	\$17.37	\$0.00	\$70.16
10	75	\$42.63	\$13.00	\$17.83	\$0.00	\$73.46

**Notes :**

App Prior 1/1/03; 30/35/40/45/50/55/65/70/75/80

**Apprentice to Journeyworker Ratio:2:3\*\*\***

ELEVATOR CONSTRUCTOR <i>ELEVATOR CONSTRUCTORS LOCAL 4</i>	01/01/2021	\$63.47	\$15.88	\$19.31	\$0.00	\$98.66
	01/01/2022	\$65.62	\$16.03	\$20.21	\$0.00	\$101.86

**Classification**

**Effective Date    Base Wage    Health    Pension    Supplemental Unemployment    Total Rate**

**Apprentice - ELEVATOR CONSTRUCTOR - Local 4**

**Effective Date - 01/01/2021**

Step	percent	Apprentice Base Wage	Health	Pension	Supplemental Unemployment	Total Rate
1	50	\$31.74	\$15.88	\$0.00	\$0.00	\$47.62
2	55	\$34.91	\$15.88	\$19.31	\$0.00	\$70.10
3	65	\$41.26	\$15.88	\$19.31	\$0.00	\$76.45
4	70	\$44.43	\$15.88	\$19.31	\$0.00	\$79.62
5	80	\$50.78	\$15.88	\$19.31	\$0.00	\$85.97

**Effective Date - 01/01/2022**

Step	percent	Apprentice Base Wage	Health	Pension	Supplemental Unemployment	Total Rate
1	50	\$32.81	\$16.03	\$0.00	\$0.00	\$48.84
2	55	\$36.09	\$16.03	\$20.21	\$0.00	\$72.33
3	65	\$42.65	\$16.03	\$20.21	\$0.00	\$78.89
4	70	\$45.93	\$16.03	\$20.21	\$0.00	\$82.17
5	80	\$52.50	\$16.03	\$20.21	\$0.00	\$88.74

**Notes:**

Steps 1-2 are 6 mos.; Steps 3-5 are 1 year

**Apprentice to Journeyworker Ratio:1:1**

ELEVATOR CONSTRUCTOR HELPER <i>ELEVATOR CONSTRUCTORS LOCAL 4</i>	01/01/2021	\$44.43	\$15.88	\$19.31	\$0.00	\$79.62
	01/01/2022	\$45.93	\$16.03	\$20.21	\$0.00	\$82.17
For apprentice rates see "Apprentice - ELEVATOR CONSTRUCTOR"						
FENCE & GUARD RAIL ERECTOR <i>LABORERS - ZONE 1</i>	06/01/2021	\$40.92	\$8.60	\$17.57	\$0.00	\$67.09
	12/01/2021	\$41.93	\$8.60	\$17.57	\$0.00	\$68.10
	06/01/2022	\$42.93	\$8.60	\$17.57	\$0.00	\$69.10
	12/01/2022	\$43.93	\$8.60	\$17.57	\$0.00	\$70.10
	06/01/2023	\$44.93	\$8.60	\$17.57	\$0.00	\$71.10
	12/01/2023	\$46.18	\$8.60	\$17.57	\$0.00	\$72.35
For apprentice rates see "Apprentice- LABORER"						
FENCE & GUARD RAIL ERECTOR (HEAVY & HIGHWAY) <i>LABORERS - ZONE 1 (HEAVY &amp; HIGHWAY)</i>	06/01/2021	\$40.92	\$8.60	\$17.57	\$0.00	\$67.09
	12/01/2021	\$41.93	\$8.60	\$17.57	\$0.00	\$68.10
For apprentice rates see "Apprentice- LABORER (Heavy and Highway)"						
FIELD ENG.INST.PERSON-BLDG,SITE,HVY/HWY <i>OPERATING ENGINEERS LOCAL 4</i>	05/01/2021	\$45.88	\$13.50	\$15.70	\$0.00	\$75.08
	11/01/2021	\$46.88	\$13.50	\$15.70	\$0.00	\$76.08
	05/01/2022	\$48.03	\$13.50	\$15.70	\$0.00	\$77.23
For apprentice rates see "Apprentice- OPERATING ENGINEERS"						
FIELD ENG.PARTY CHIEF-BLDG,SITE,HVY/HWY <i>OPERATING ENGINEERS LOCAL 4</i>	05/01/2021	\$47.40	\$13.50	\$15.70	\$0.00	\$76.60
	11/01/2021	\$48.41	\$13.50	\$15.70	\$0.00	\$77.61
	05/01/2022	\$49.57	\$13.50	\$15.70	\$0.00	\$78.77
For apprentice rates see "Apprentice- OPERATING ENGINEERS"						
FIELD ENG.ROD PERSON-BLDG,SITE,HVY/HWY <i>OPERATING ENGINEERS LOCAL 4</i>	05/01/2021	\$22.91	\$13.50	\$15.70	\$0.00	\$52.11
	11/01/2021	\$23.51	\$13.50	\$15.70	\$0.00	\$52.71
	05/01/2022	\$24.18	\$13.50	\$15.70	\$0.00	\$53.38
For apprentice rates see "Apprentice- OPERATING ENGINEERS"						

<b>Classification</b>	<b>Effective Date</b>	<b>Base Wage</b>	<b>Health</b>	<b>Pension</b>	<b>Supplemental Unemployment</b>	<b>Total Rate</b>
<b>FIRE ALARM INSTALLER</b> <i>ELECTRICIANS LOCAL 103</i>	03/01/2021	\$55.41	\$13.00	\$20.01	\$0.00	\$88.42
	09/01/2021	\$56.84	\$13.00	\$20.06	\$0.00	\$89.90
	03/01/2022	\$58.04	\$13.00	\$20.09	\$0.00	\$91.13
	09/01/2022	\$59.48	\$13.00	\$20.13	\$0.00	\$92.61
	03/01/2023	\$60.67	\$13.00	\$20.17	\$0.00	\$93.84
For apprentice rates see "Apprentice- ELECTRICIAN"						
<b>FIRE ALARM REPAIR / MAINTENANCE</b> <i>LOCAL 103</i> / COMMISSIONING <i>ELECTRICIANS</i>	03/01/2021	\$42.11	\$13.00	\$17.88	\$0.00	\$72.99
	09/01/2021	\$43.77	\$13.00	\$18.00	\$0.00	\$74.77
	03/01/2022	\$45.27	\$13.00	\$18.12	\$0.00	\$76.39
	09/01/2022	\$46.99	\$13.00	\$18.24	\$0.00	\$78.23
	03/01/2023	\$48.54	\$13.00	\$18.37	\$0.00	\$79.91
For apprentice rates see "Apprentice- TELECOMMUNICATIONS TECHNICIAN"						
<b>FIREMAN (ASST. ENGINEER)</b> <i>OPERATING ENGINEERS LOCAL 4</i>	06/01/2021	\$41.31	\$13.75	\$15.80	\$0.00	\$70.86
	12/01/2021	\$42.26	\$13.75	\$15.80	\$0.00	\$71.81
For apprentice rates see "Apprentice- OPERATING ENGINEERS"						
<b>FLAGGER &amp; SIGNALER (HEAVY &amp; HIGHWAY)</b> <i>LABORERS - ZONE 1 (HEAVY &amp; HIGHWAY)</i>	06/01/2021	\$24.50	\$8.60	\$17.57	\$0.00	\$50.67
	12/01/2021	\$24.50	\$8.60	\$17.57	\$0.00	\$50.67
For apprentice rates see "Apprentice- LABORER (Heavy and Highway)"						
<b>FLOORCOVERER</b> <i>FLOORCOVERERS LOCAL 2168 ZONE 1</i>	03/01/2021	\$48.59	\$9.40	\$19.25	\$0.00	\$77.24
	09/01/2021	\$49.39	\$9.40	\$19.25	\$0.00	\$78.04
	03/01/2022	\$50.19	\$9.40	\$19.25	\$0.00	\$78.84

**Classification**

**Effective Date    Base Wage    Health    Pension    Supplemental Unemployment    Total Rate**

**Apprentice - FLOORCOVERER - Local 2168 Zone I**

**Effective Date - 03/01/2021**

Step	percent	Apprentice Base Wage	Health	Pension	Supplemental Unemployment	Total Rate
1	50	\$24.30	\$9.40	\$1.79	\$0.00	\$35.49
2	55	\$26.72	\$9.40	\$1.79	\$0.00	\$37.91
3	60	\$29.15	\$9.40	\$13.88	\$0.00	\$52.43
4	65	\$31.58	\$9.40	\$13.88	\$0.00	\$54.86
5	70	\$34.01	\$9.40	\$15.67	\$0.00	\$59.08
6	75	\$36.44	\$9.40	\$15.67	\$0.00	\$61.51
7	80	\$38.87	\$9.40	\$17.46	\$0.00	\$65.73
8	85	\$41.30	\$9.40	\$17.46	\$0.00	\$68.16

**Effective Date - 09/01/2021**

Step	percent	Apprentice Base Wage	Health	Pension	Supplemental Unemployment	Total Rate
1	50	\$24.70	\$9.40	\$1.79	\$0.00	\$35.89
2	55	\$27.16	\$9.40	\$1.79	\$0.00	\$38.35
3	60	\$29.63	\$9.40	\$13.88	\$0.00	\$52.91
4	65	\$32.10	\$9.40	\$13.88	\$0.00	\$55.38
5	70	\$34.57	\$9.40	\$15.67	\$0.00	\$59.64
6	75	\$37.04	\$9.40	\$15.67	\$0.00	\$62.11
7	80	\$39.51	\$9.40	\$17.46	\$0.00	\$66.37
8	85	\$41.98	\$9.40	\$17.46	\$0.00	\$68.84

**Notes:** Steps are 750 hrs.  
 % After 09/1/17; 45/45/55/55/70/70/80/80 (1500hr Steps)  
 Step 1&2 \$33.03/ 3&4 \$39.64/ 5&6 \$59.08/ 7&8 \$65.73

**Apprentice to Journeyworker Ratio:1:1**

FORK LIFT/CHERRY PICKER OPERATING ENGINEERS LOCAL 4	06/01/2021	\$50.73	\$13.75	\$15.80	\$0.00	\$80.28
	12/01/2021	\$51.88	\$13.75	\$15.80	\$0.00	\$81.43

For apprentice rates see "Apprentice- OPERATING ENGINEERS"

GENERATOR/LIGHTING PLANT/HEATERS OPERATING ENGINEERS LOCAL 4	06/01/2021	\$33.40	\$13.75	\$15.80	\$0.00	\$62.95
	12/01/2021	\$34.19	\$13.75	\$15.80	\$0.00	\$63.74

For apprentice rates see "Apprentice- OPERATING ENGINEERS"

GLAZIER (GLASS PLANK/AIR BARRIER/INTERIOR SYSTEMS) GLAZIERS LOCAL 35 (ZONE 2)	01/01/2021	\$41.56	\$8.25	\$22.75	\$0.00	\$72.56
--	------------	---------	--------	---------	--------	---------



**Classification**

**Effective Date    Base Wage    Health    Pension    Supplemental Unemployment    Total Rate**

**Apprentice - GLAZIER - Local 35 Zone 2**

**Effective Date - 01/01/2021**

Step	percent	Apprentice Base Wage	Health	Pension	Supplemental Unemployment	Total Rate
1	50	\$20.78	\$8.25	\$0.00	\$0.00	\$29.03
2	55	\$22.86	\$8.25	\$6.16	\$0.00	\$37.27
3	60	\$24.94	\$8.25	\$6.72	\$0.00	\$39.91
4	65	\$27.01	\$8.25	\$7.28	\$0.00	\$42.54
5	70	\$29.09	\$8.25	\$19.39	\$0.00	\$56.73
6	75	\$31.17	\$8.25	\$19.95	\$0.00	\$59.37
7	80	\$33.25	\$8.25	\$20.51	\$0.00	\$62.01
8	90	\$37.40	\$8.25	\$21.63	\$0.00	\$67.28

**Notes:**

Steps are 750 hrs.

**Apprentice to Journeyworker Ratio:1:1**

HOISTING ENGINEER/CRANES/GRADALLS	06/01/2021	\$50.73	\$13.75	\$15.80	\$0.00	\$80.28
OPERATING ENGINEERS LOCAL 4	12/01/2021	\$51.88	\$13.75	\$15.80	\$0.00	\$81.43

**Classification**

**Effective Date    Base Wage    Health    Pension    Supplemental Unemployment    Total Rate**

**Apprentice - OPERATING ENGINEERS - Local 4**

**Effective Date - 06/01/2021**

Step	percent	Apprentice Base Wage	Health	Pension	Supplemental Unemployment	Total Rate
1	55	\$27.90	\$13.75	\$0.00	\$0.00	\$41.65
2	60	\$30.44	\$13.75	\$15.80	\$0.00	\$59.99
3	65	\$32.97	\$13.75	\$15.80	\$0.00	\$62.52
4	70	\$35.51	\$13.75	\$15.80	\$0.00	\$65.06
5	75	\$38.05	\$13.75	\$15.80	\$0.00	\$67.60
6	80	\$40.58	\$13.75	\$15.80	\$0.00	\$70.13
7	85	\$43.12	\$13.75	\$15.80	\$0.00	\$72.67
8	90	\$45.66	\$13.75	\$15.80	\$0.00	\$75.21

**Effective Date - 12/01/2021**

Step	percent	Apprentice Base Wage	Health	Pension	Supplemental Unemployment	Total Rate
1	55	\$28.53	\$13.75	\$0.00	\$0.00	\$42.28
2	60	\$31.13	\$13.75	\$15.80	\$0.00	\$60.68
3	65	\$33.72	\$13.75	\$15.80	\$0.00	\$63.27
4	70	\$36.32	\$13.75	\$15.80	\$0.00	\$65.87
5	75	\$38.91	\$13.75	\$15.80	\$0.00	\$68.46
6	80	\$41.50	\$13.75	\$15.80	\$0.00	\$71.05
7	85	\$44.10	\$13.75	\$15.80	\$0.00	\$73.65
8	90	\$46.69	\$13.75	\$15.80	\$0.00	\$76.24

**Notes:**

**Apprentice to Journeyworker Ratio:1:6**

HVAC (DUCTWORK) SHEETMETAL WORKERS LOCAL 17 - A	02/01/2021	\$51.67	\$13.65	\$24.57	\$2.70	\$92.59
	08/01/2021	\$53.42	\$13.65	\$24.57	\$2.75	\$94.39
	02/01/2022	\$55.17	\$13.65	\$24.57	\$2.80	\$96.19

For apprentice rates see "Apprentice- SHEET METAL WORKER"

HVAC (ELECTRICAL CONTROLS) ELECTRICIANS LOCAL 103	03/01/2021	\$55.41	\$13.00	\$20.01	\$0.00	\$88.42
	09/01/2021	\$56.84	\$13.00	\$20.06	\$0.00	\$89.90
	03/01/2022	\$58.04	\$13.00	\$20.09	\$0.00	\$91.13
	09/01/2022	\$59.48	\$13.00	\$20.13	\$0.00	\$92.61
	03/01/2023	\$60.67	\$13.00	\$20.17	\$0.00	\$93.84

For apprentice rates see "Apprentice- ELECTRICIAN"

HVAC (TESTING AND BALANCING - AIR) SHEETMETAL WORKERS LOCAL 17 - A	02/01/2021	\$51.67	\$13.65	\$24.57	\$2.70	\$92.59
	08/01/2021	\$53.42	\$13.65	\$24.57	\$2.75	\$94.39
	02/01/2022	\$55.17	\$13.65	\$24.57	\$2.80	\$96.19

For apprentice rates see "Apprentice- SHEET METAL WORKER"

HVAC (TESTING AND BALANCING - WATER) PIPEFITTERS LOCAL 537	03/01/2021	\$57.94	\$11.70	\$20.24	\$0.00	\$89.88
---	------------	---------	---------	---------	--------	---------

For apprentice rates see "Apprentice- PIPEFITTER" or "PLUMBER/PIPEFITTER"

HVAC MECHANIC PIPEFITTERS LOCAL 537	03/01/2021	\$57.94	\$11.70	\$20.24	\$0.00	\$89.88
--	------------	---------	---------	---------	--------	---------

Classification	Effective Date	Base Wage	Health	Pension	Supplemental Unemployment	Total Rate
For apprentice rates see "Apprentice- PIPEFITTER" or "PLUMBER/PIPEFITTER"						
HYDRAULIC DRILLS <i>LABORERS - ZONE 1</i>	06/01/2021	\$41.42	\$8.60	\$17.57	\$0.00	\$67.59
	12/01/2021	\$42.43	\$8.60	\$17.57	\$0.00	\$68.60
	06/01/2022	\$43.43	\$8.60	\$17.57	\$0.00	\$69.60
	12/01/2022	\$44.43	\$8.60	\$17.57	\$0.00	\$70.60
	06/01/2023	\$45.43	\$8.60	\$17.57	\$0.00	\$71.60
	12/01/2023	\$46.68	\$8.60	\$17.57	\$0.00	\$72.85
For apprentice rates see "Apprentice- LABORER"						
HYDRAULIC DRILLS (HEAVY & HIGHWAY) <i>LABORERS - ZONE 1 (HEAVY &amp; HIGHWAY)</i>	06/01/2021	\$41.42	\$8.60	\$17.57	\$0.00	\$67.59
	12/01/2021	\$42.43	\$8.60	\$17.57	\$0.00	\$68.60
For apprentice rates see "Apprentice- LABORER (Heavy and Highway)"						
INSULATOR (PIPES & TANKS) <i>HEAT &amp; FROST INSULATORS LOCAL 6 (BOSTON)</i>	09/01/2020	\$49.00	\$13.80	\$17.14	\$0.00	\$79.94
	09/01/2021	\$51.40	\$13.80	\$17.14	\$0.00	\$82.34
	09/01/2022	\$53.85	\$13.80	\$17.14	\$0.00	\$84.79

**Apprentice - ASBESTOS INSULATOR (Pipes & Tanks) - Local 6 Boston**

**Effective Date - 09/01/2020**

Step	percent	Apprentice Base Wage	Health	Pension	Supplemental Unemployment	Total Rate
1	50	\$24.50	\$13.80	\$12.42	\$0.00	\$50.72
2	60	\$29.40	\$13.80	\$13.36	\$0.00	\$56.56
3	70	\$34.30	\$13.80	\$14.31	\$0.00	\$62.41
4	80	\$39.20	\$13.80	\$15.25	\$0.00	\$68.25

**Effective Date - 09/01/2021**

Step	percent	Apprentice Base Wage	Health	Pension	Supplemental Unemployment	Total Rate
1	50	\$25.70	\$13.80	\$12.42	\$0.00	\$51.92
2	60	\$30.84	\$13.80	\$13.36	\$0.00	\$58.00
3	70	\$35.98	\$13.80	\$14.31	\$0.00	\$64.09
4	80	\$41.12	\$13.80	\$15.25	\$0.00	\$70.17

**Notes:**

Steps are 1 year

**Apprentice to Journeyworker Ratio:1:4**

IRONWORKER/WELDER <i>IRONWORKERS LOCAL 7 (BOSTON AREA)</i>	09/16/2020	\$48.66	\$8.10	\$25.10	\$0.00	\$81.86
---	------------	---------	--------	---------	--------	---------

**Classification**

**Effective Date    Base Wage    Health    Pension    Supplemental Unemployment    Total Rate**

**Apprentice - IRONWORKER - Local 7 Boston**

**Effective Date - 09/16/2020**

Step	percent	Apprentice Base Wage	Health	Pension	Supplemental Unemployment	Total Rate
1	60	\$29.20	\$8.10	\$25.10	\$0.00	\$62.40
2	70	\$34.06	\$8.10	\$25.10	\$0.00	\$67.26
3	75	\$36.50	\$8.10	\$25.10	\$0.00	\$69.70
4	80	\$38.93	\$8.10	\$25.10	\$0.00	\$72.13
5	85	\$41.36	\$8.10	\$25.10	\$0.00	\$74.56
6	90	\$43.79	\$8.10	\$25.10	\$0.00	\$76.99

**Notes:**

\*\* Structural 1:6; Ornamental 1:4

**Apprentice to Journeyworker Ratio:\*\***

JACKHAMMER & PAVING BREAKER OPERATOR LABORERS - ZONE 1	06/01/2021	\$40.92	\$8.60	\$17.57	\$0.00	\$67.09
	12/01/2021	\$41.93	\$8.60	\$17.57	\$0.00	\$68.10
	06/01/2022	\$42.93	\$8.60	\$17.57	\$0.00	\$69.10
	12/01/2022	\$43.93	\$8.60	\$17.57	\$0.00	\$70.10
	06/01/2023	\$44.93	\$8.60	\$17.57	\$0.00	\$71.10
	12/01/2023	\$46.18	\$8.60	\$17.57	\$0.00	\$72.35

For apprentice rates see "Apprentice- LABORER"

LABORER LABORERS - ZONE 1	06/01/2021	\$40.67	\$8.60	\$17.57	\$0.00	\$66.84
	12/01/2021	\$41.68	\$8.60	\$17.57	\$0.00	\$67.85
	06/01/2022	\$42.68	\$8.60	\$17.57	\$0.00	\$68.85
	12/01/2022	\$43.68	\$8.60	\$17.57	\$0.00	\$69.85
	06/01/2023	\$44.68	\$8.60	\$17.57	\$0.00	\$70.85
	12/01/2023	\$45.93	\$8.60	\$17.57	\$0.00	\$72.10

**Classification**

**Effective Date   Base Wage   Health   Pension   Supplemental Unemployment   Total Rate**

**Apprentice - LABORER - Zone 1**

**Effective Date - 06/01/2021**

Step	percent	Apprentice Base Wage	Health	Pension	Supplemental Unemployment	Total Rate
1	60	\$24.40	\$8.60	\$17.57	\$0.00	\$50.57
2	70	\$28.47	\$8.60	\$17.57	\$0.00	\$54.64
3	80	\$32.54	\$8.60	\$17.57	\$0.00	\$58.71
4	90	\$36.60	\$8.60	\$17.57	\$0.00	\$62.77

**Effective Date - 12/01/2021**

Step	percent	Apprentice Base Wage	Health	Pension	Supplemental Unemployment	Total Rate
1	60	\$25.01	\$8.60	\$17.57	\$0.00	\$51.18
2	70	\$29.18	\$8.60	\$17.57	\$0.00	\$55.35
3	80	\$33.34	\$8.60	\$17.57	\$0.00	\$59.51
4	90	\$37.51	\$8.60	\$17.57	\$0.00	\$63.68

**Notes:**

**Apprentice to Journeyworker Ratio:1:5**

LABORER (HEAVY & HIGHWAY)	06/01/2021	\$40.67	\$8.60	\$17.57	\$0.00	\$66.84
LABORERS - ZONE 1 (HEAVY & HIGHWAY)	12/01/2021	\$41.68	\$8.60	\$17.57	\$0.00	\$67.85

**Apprentice - LABORER (Heavy & Highway) - Zone 1**

**Effective Date - 06/01/2021**

Step	percent	Apprentice Base Wage	Health	Pension	Supplemental Unemployment	Total Rate
1	60	\$24.40	\$8.60	\$17.57	\$0.00	\$50.57
2	70	\$28.47	\$8.60	\$17.57	\$0.00	\$54.64
3	80	\$32.54	\$8.60	\$17.57	\$0.00	\$58.71
4	90	\$36.60	\$8.60	\$17.57	\$0.00	\$62.77

**Effective Date - 12/01/2021**

Step	percent	Apprentice Base Wage	Health	Pension	Supplemental Unemployment	Total Rate
1	60	\$25.01	\$8.60	\$17.57	\$0.00	\$51.18
2	70	\$29.18	\$8.60	\$17.57	\$0.00	\$55.35
3	80	\$33.34	\$8.60	\$17.57	\$0.00	\$59.51
4	90	\$37.51	\$8.60	\$17.57	\$0.00	\$63.68

**Notes:**

**Apprentice to Journeyworker Ratio:1:5**

Classification	Effective Date	Base Wage	Health	Pension	Supplemental Unemployment	Total Rate
LABORER: CARPENTER TENDER <i>LABORERS - ZONE 1</i>	06/01/2021	\$40.67	\$8.60	\$17.57	\$0.00	\$66.84
	12/01/2021	\$41.68	\$8.60	\$17.57	\$0.00	\$67.85
	06/01/2022	\$42.68	\$8.60	\$17.57	\$0.00	\$68.85
	12/01/2022	\$43.68	\$8.60	\$17.57	\$0.00	\$69.85
	06/01/2023	\$44.68	\$8.60	\$17.57	\$0.00	\$70.85
	12/01/2023	\$45.93	\$8.60	\$17.57	\$0.00	\$72.10
For apprentice rates see "Apprentice- LABORER"						
LABORER: CEMENT FINISHER TENDER <i>LABORERS - ZONE 1</i>	06/01/2021	\$40.67	\$8.60	\$17.57	\$0.00	\$66.84
	12/01/2021	\$41.68	\$8.60	\$17.57	\$0.00	\$67.85
	06/01/2022	\$42.68	\$8.60	\$17.57	\$0.00	\$68.85
	12/01/2022	\$43.68	\$8.60	\$17.57	\$0.00	\$69.85
	06/01/2023	\$44.68	\$8.60	\$17.57	\$0.00	\$70.85
	12/01/2023	\$45.93	\$8.60	\$17.57	\$0.00	\$72.10
For apprentice rates see "Apprentice- LABORER"						
LABORER: HAZARDOUS WASTE/ASBESTOS REMOVER <i>LABORERS - ZONE 1</i>	06/01/2021	\$40.82	\$8.60	\$17.57	\$0.00	\$66.99
	12/01/2021	\$41.83	\$8.60	\$17.57	\$0.00	\$68.00
	06/01/2022	\$42.83	\$8.60	\$17.57	\$0.00	\$69.00
	12/01/2022	\$43.83	\$8.60	\$17.57	\$0.00	\$70.00
	06/01/2023	\$44.83	\$8.60	\$17.57	\$0.00	\$71.00
	12/01/2023	\$46.08	\$8.60	\$17.57	\$0.00	\$72.25
For apprentice rates see "Apprentice- LABORER"						
LABORER: MASON TENDER <i>LABORERS - ZONE 1</i>	06/01/2021	\$40.92	\$8.60	\$17.57	\$0.00	\$67.09
	12/01/2021	\$41.93	\$8.60	\$17.57	\$0.00	\$68.10
	06/01/2022	\$42.93	\$8.60	\$17.57	\$0.00	\$69.10
	12/01/2022	\$43.93	\$8.60	\$17.57	\$0.00	\$70.10
	06/01/2023	\$44.93	\$8.60	\$17.57	\$0.00	\$71.10
	06/01/2024	\$46.18	\$8.60	\$17.57	\$0.00	\$72.35
For apprentice rates see "Apprentice- LABORER"						
LABORER: MASON TENDER (HEAVY & HIGHWAY) <i>LABORERS - ZONE 1 (HEAVY &amp; HIGHWAY)</i>	06/01/2021	\$40.92	\$8.60	\$17.57	\$0.00	\$67.09
	12/01/2021	\$41.93	\$8.60	\$17.57	\$0.00	\$68.10
For apprentice rates see "Apprentice- LABORER (Heavy and Highway)"						
LABORER: MULTI-TRADE TENDER <i>LABORERS - ZONE 1</i>	06/01/2021	\$40.67	\$8.60	\$17.57	\$0.00	\$66.84
	12/01/2021	\$41.68	\$8.60	\$17.57	\$0.00	\$67.85
	06/01/2022	\$42.68	\$8.60	\$17.57	\$0.00	\$68.85
	12/01/2022	\$43.68	\$8.60	\$17.57	\$0.00	\$69.85
	06/01/2023	\$44.68	\$8.60	\$17.57	\$0.00	\$70.85
	12/01/2023	\$45.93	\$8.60	\$17.57	\$0.00	\$72.10
For apprentice rates see "Apprentice- LABORER"						
LABORER: TREE REMOVER <i>LABORERS - ZONE 1</i>	06/01/2021	\$40.67	\$8.60	\$17.57	\$0.00	\$66.84
	12/01/2021	\$41.68	\$8.60	\$17.57	\$0.00	\$67.85
	06/01/2022	\$42.68	\$8.60	\$17.57	\$0.00	\$68.85
	12/01/2022	\$43.68	\$8.60	\$17.57	\$0.00	\$69.85
	06/01/2023	\$44.68	\$8.60	\$17.57	\$0.00	\$70.85
	12/01/2023	\$45.93	\$8.60	\$17.57	\$0.00	\$72.10
This classification applies to the removal of standing trees, and the trimming and removal of branches and limbs when related to public works construction or site clearance incidental to construction . For apprentice rates see "Apprentice- LABORER"						

Classification	Effective Date	Base Wage	Health	Pension	Supplemental Unemployment	Total Rate
LASER BEAM OPERATOR <i>LABORERS - ZONE 1</i>	06/01/2021	\$40.92	\$8.60	\$17.57	\$0.00	\$67.09
	12/01/2021	\$41.93	\$8.60	\$17.57	\$0.00	\$68.10
	06/01/2022	\$42.93	\$8.60	\$17.57	\$0.00	\$69.10
	12/01/2022	\$43.93	\$8.60	\$17.57	\$0.00	\$70.10
	06/01/2023	\$44.93	\$8.60	\$17.57	\$0.00	\$71.10
	12/01/2023	\$46.18	\$8.60	\$17.57	\$0.00	\$72.35

For apprentice rates see "Apprentice- LABORER"

LASER BEAM OPERATOR (HEAVY & HIGHWAY) <i>LABORERS - ZONE 1 (HEAVY &amp; HIGHWAY)</i>	06/01/2021	\$40.92	\$8.60	\$17.57	\$0.00	\$67.09
	12/01/2021	\$41.93	\$8.60	\$17.57	\$0.00	\$68.10

For apprentice rates see "Apprentice- LABORER (Heavy and Highway)"

MARBLE & TILE FINISHERS <i>BRICKLAYERS LOCAL 3 - MARBLE &amp; TILE</i>	02/01/2021	\$42.57	\$11.39	\$20.14	\$0.00	\$74.10
	08/01/2021	\$43.69	\$11.39	\$20.30	\$0.00	\$75.38
	02/01/2022	\$44.16	\$11.39	\$20.30	\$0.00	\$75.85

**Apprentice - MARBLE & TILE FINISHER - Local 3 Marble & Tile**

**Effective Date - 02/01/2021**

Step	percent	Apprentice Base Wage	Health	Pension	Supplemental Unemployment	Total Rate
1	50	\$21.29	\$11.39	\$20.14	\$0.00	\$52.82
2	60	\$25.54	\$11.39	\$20.14	\$0.00	\$57.07
3	70	\$29.80	\$11.39	\$20.14	\$0.00	\$61.33
4	80	\$34.06	\$11.39	\$20.14	\$0.00	\$65.59
5	90	\$38.31	\$11.39	\$20.14	\$0.00	\$69.84

**Effective Date - 08/01/2021**

Step	percent	Apprentice Base Wage	Health	Pension	Supplemental Unemployment	Total Rate
1	50	\$21.85	\$11.39	\$20.30	\$0.00	\$53.54
2	60	\$26.21	\$11.39	\$20.30	\$0.00	\$57.90
3	70	\$30.58	\$11.39	\$20.30	\$0.00	\$62.27
4	80	\$34.95	\$11.39	\$20.30	\$0.00	\$66.64
5	90	\$39.32	\$11.39	\$20.30	\$0.00	\$71.01

Notes:

**Apprentice to Journeyworker Ratio:1:3**

MARBLE MASONS, TILELAYERS & TERRAZZO MECH <i>BRICKLAYERS LOCAL 3 - MARBLE &amp; TILE</i>	02/01/2021	\$55.77	\$11.39	\$22.08	\$0.00	\$89.24
	08/01/2021	\$57.17	\$11.39	\$22.24	\$0.00	\$90.80
	02/01/2022	\$57.74	\$11.39	\$22.24	\$0.00	\$91.37

**Classification**

**Effective Date    Base Wage    Health    Pension    Supplemental Unemployment    Total Rate**

**Apprentice - MARBLE-TILE-TERRAZZO MECHANIC - Local 3 Marble & Tile**

**Effective Date - 02/01/2021**

Step	percent	Apprentice Base Wage	Health	Pension	Supplemental Unemployment	Total Rate
1	50	\$27.89	\$11.39	\$22.08	\$0.00	\$61.36
2	60	\$33.46	\$11.39	\$22.08	\$0.00	\$66.93
3	70	\$39.04	\$11.39	\$22.08	\$0.00	\$72.51
4	80	\$44.62	\$11.39	\$22.08	\$0.00	\$78.09
5	90	\$50.19	\$11.39	\$22.08	\$0.00	\$83.66

**Effective Date - 08/01/2021**

Step	percent	Apprentice Base Wage	Health	Pension	Supplemental Unemployment	Total Rate
1	50	\$28.59	\$11.39	\$22.24	\$0.00	\$62.22
2	60	\$34.30	\$11.39	\$22.24	\$0.00	\$67.93
3	70	\$40.02	\$11.39	\$22.24	\$0.00	\$73.65
4	80	\$45.74	\$11.39	\$22.24	\$0.00	\$79.37
5	90	\$51.45	\$11.39	\$22.24	\$0.00	\$85.08

**Notes:**

**Apprentice to Journeyworker Ratio:1:5**

MECH. SWEEPER OPERATOR (ON CONST. SITES) OPERATING ENGINEERS LOCAL 4	06/01/2021	\$50.19	\$13.75	\$15.80	\$0.00	\$79.74
	12/01/2021	\$51.33	\$13.75	\$15.80	\$0.00	\$80.88

For apprentice rates see "Apprentice- OPERATING ENGINEERS"

MECHANICS MAINTENANCE OPERATING ENGINEERS LOCAL 4	06/01/2021	\$50.19	\$13.75	\$15.80	\$0.00	\$79.74
	12/01/2021	\$51.33	\$13.75	\$15.80	\$0.00	\$80.88

For apprentice rates see "Apprentice- OPERATING ENGINEERS"

MILLWRIGHT (Zone 1) MILLWRIGHTS LOCAL 1121 - Zone 1	01/04/2021	\$44.07	\$9.40	\$20.45	\$0.00	\$73.92
	01/03/2022	\$45.82	\$9.40	\$20.45	\$0.00	\$75.67
	01/02/2023	\$47.57	\$9.40	\$20.45	\$0.00	\$77.42



**Apprentice - MILLWRIGHT - Local 1121 Zone 1**

**Effective Date - 01/04/2021**

Step	percent	Apprentice Base Wage	Health	Pension	Supplemental Unemployment	Total Rate
1	55	\$24.24	\$9.40	\$5.58	\$0.00	\$39.22
2	65	\$28.65	\$9.40	\$16.90	\$0.00	\$54.95
3	75	\$33.05	\$9.40	\$17.92	\$0.00	\$60.37
4	85	\$37.46	\$9.40	\$18.93	\$0.00	\$65.79

**Effective Date - 01/03/2022**

Step	percent	Apprentice Base Wage	Health	Pension	Supplemental Unemployment	Total Rate
1	55	\$25.20	\$9.40	\$5.58	\$0.00	\$40.18
2	65	\$29.78	\$9.40	\$16.90	\$0.00	\$56.08
3	75	\$34.37	\$9.40	\$17.92	\$0.00	\$61.69
4	85	\$38.95	\$9.40	\$18.93	\$0.00	\$67.28

**Notes:** Step 1&2 Appr. indentured after 1/1/2020 receive no pension, but do receive annuity. (Step 1 \$5.58, Step 2 \$6.50)  
Steps are 2,000 hours

**Apprentice to Journeyworker Ratio:1:5**

MORTAR MIXER LABORERS - ZONE 1	06/01/2021	\$40.92	\$8.60	\$17.57	\$0.00	\$67.09
	12/01/2021	\$41.93	\$8.60	\$17.57	\$0.00	\$68.10
	06/01/2022	\$42.93	\$8.60	\$17.57	\$0.00	\$69.10
	12/01/2022	\$43.93	\$8.60	\$17.57	\$0.00	\$70.10
	06/01/2023	\$44.93	\$8.60	\$17.57	\$0.00	\$71.10
	12/01/2023	\$46.18	\$8.60	\$17.57	\$0.00	\$72.35
For apprentice rates see "Apprentice- LABORER"						
OILER (OTHER THAN TRUCK CRANES,GRADALLS) OPERATING ENGINEERS LOCAL 4	06/01/2021	\$23.40	\$13.75	\$15.80	\$0.00	\$52.95
	12/01/2021	\$23.98	\$13.75	\$15.80	\$0.00	\$53.53
For apprentice rates see "Apprentice- OPERATING ENGINEERS"						
OILER (TRUCK CRANES, GRADALLS) OPERATING ENGINEERS LOCAL 4	06/01/2021	\$28.26	\$13.75	\$15.80	\$0.00	\$57.81
	12/01/2021	\$28.94	\$13.75	\$15.80	\$0.00	\$58.49
For apprentice rates see "Apprentice- OPERATING ENGINEERS"						
OTHER POWER DRIVEN EQUIPMENT - CLASS II OPERATING ENGINEERS LOCAL 4	06/01/2021	\$50.19	\$13.75	\$15.80	\$0.00	\$79.74
	12/01/2021	\$51.33	\$13.75	\$15.80	\$0.00	\$80.88
For apprentice rates see "Apprentice- OPERATING ENGINEERS"						
PAINTER (BRIDGES/TANKS) PAINTERS LOCAL 35 - ZONE 2	01/01/2021	\$52.06	\$8.25	\$22.75	\$0.00	\$83.06





**Classification**

**Effective Date    Base Wage    Health    Pension    Supplemental Unemployment    Total Rate**

**Apprentice - PAINTER Local 35 Zone 2 - BRUSH REPAINT**

**Effective Date - 01/01/2021**

Step	percent	Apprentice Base Wage	Health	Pension	Supplemental Unemployment	Total Rate
1	50	\$19.81	\$8.25	\$0.00	\$0.00	\$28.06
2	55	\$21.79	\$8.25	\$6.16	\$0.00	\$36.20
3	60	\$23.77	\$8.25	\$6.72	\$0.00	\$38.74
4	65	\$25.75	\$8.25	\$7.28	\$0.00	\$41.28
5	70	\$27.73	\$8.25	\$19.39	\$0.00	\$55.37
6	75	\$29.72	\$8.25	\$19.95	\$0.00	\$57.92
7	80	\$31.70	\$8.25	\$20.51	\$0.00	\$60.46
8	90	\$35.66	\$8.25	\$21.63	\$0.00	\$65.54

**Notes:**

Steps are 750 hrs.

**Apprentice to Journeyworker Ratio:1:1**

PAINTER TRAFFIC MARKINGS (HEAVY/HIGHWAY)	06/01/2021	\$40.67	\$8.60	\$17.57	\$0.00	\$66.84
LABORERS - ZONE 1 (HEAVY & HIGHWAY)	12/01/2021	\$41.68	\$8.60	\$17.57	\$0.00	\$67.85

For apprentice rates see "Apprentice- LABORER (Heavy and Highway)

PANEL & PICKUP TRUCKS DRIVER	06/01/2021	\$36.88	\$12.91	\$14.82	\$0.00	\$64.61
TEAMSTERS JOINT COUNCIL NO. 10 ZONE A	08/01/2021	\$36.88	\$13.41	\$14.82	\$0.00	\$65.11
	12/01/2021	\$36.88	\$13.41	\$16.01	\$0.00	\$66.30

PIER AND DOCK CONSTRUCTOR (UNDERPINNING AND DECK)	08/01/2020	\$49.07	\$9.40	\$23.12	\$0.00	\$81.59
PILE DRIVER LOCAL 56 (ZONE 1)						

For apprentice rates see "Apprentice- PILE DRIVER"

PILE DRIVER	08/01/2020	\$49.07	\$9.40	\$23.12	\$0.00	\$81.59
PILE DRIVER LOCAL 56 (ZONE 1)						

**Apprentice - PILE DRIVER - Local 56 Zone 1**

**Effective Date - 08/01/2020**

Step	percent	Apprentice Base Wage	Health	Pension	Supplemental Unemployment	Total Rate
1	50	\$24.54	\$9.40	\$23.12	\$0.00	\$57.06
2	60	\$29.44	\$9.40	\$23.12	\$0.00	\$61.96
3	70	\$34.35	\$9.40	\$23.12	\$0.00	\$66.87
4	75	\$36.80	\$9.40	\$23.12	\$0.00	\$69.32
5	80	\$39.26	\$9.40	\$23.12	\$0.00	\$71.78
6	80	\$39.26	\$9.40	\$23.12	\$0.00	\$71.78
7	90	\$44.16	\$9.40	\$23.12	\$0.00	\$76.68
8	90	\$44.16	\$9.40	\$23.12	\$0.00	\$76.68

**Notes:**

% Indentured After 10/1/17; 45/45/55/55/70/70/80/80  
Step 1&2 \$34.01/ 3&4 \$41.46/ 5&6 \$62.80/ 7&8 \$69.25

**Apprentice to Journeyworker Ratio:1:5**

Classification	Effective Date	Base Wage	Health	Pension	Supplemental Unemployment	Total Rate
PIPEFITTER & STEAMFITTER <i>PIPEFITTERS LOCAL 537</i>	03/01/2021	\$57.94	\$11.70	\$20.24	\$0.00	\$89.88

**Apprentice - PIPEFITTER - Local 537**

**Effective Date - 03/01/2021**

Step	percent	Apprentice Base Wage	Health	Pension	Supplemental Unemployment	Total Rate
1	40	\$23.18	\$11.70	\$8.25	\$0.00	\$43.13
2	45	\$26.07	\$11.70	\$20.24	\$0.00	\$58.01
3	60	\$34.76	\$11.70	\$20.24	\$0.00	\$66.70
4	70	\$40.56	\$11.70	\$20.24	\$0.00	\$72.50
5	80	\$46.35	\$11.70	\$20.24	\$0.00	\$78.29

**Notes:**

\*\* 1:3; 3:15; 1:10 thereafter / Steps are 1 yr.

Refrig/AC Mechanic \*\*1:1;1:2;2:4;3:6;4:8;5:10;6:12;7:14;8:17;9:20;10:23(Max)

**Apprentice to Journeyworker Ratio:\*\***

PIPELAYER <i>LABORERS - ZONE 1</i>	06/01/2021	\$40.92	\$8.60	\$17.57	\$0.00	\$67.09
	12/01/2021	\$41.93	\$8.60	\$17.57	\$0.00	\$68.10
	06/01/2022	\$42.93	\$8.60	\$17.57	\$0.00	\$69.10
	12/01/2022	\$43.93	\$8.60	\$17.57	\$0.00	\$70.10
	06/01/2023	\$44.93	\$8.60	\$17.57	\$0.00	\$71.10
	12/01/2023	\$46.18	\$8.60	\$17.57	\$0.00	\$72.35

For apprentice rates see "Apprentice- LABORER"

PIPELAYER (HEAVY & HIGHWAY) <i>LABORERS - ZONE 1 (HEAVY &amp; HIGHWAY)</i>	06/01/2021	\$40.92	\$8.60	\$17.57	\$0.00	\$67.09
	12/01/2021	\$41.93	\$8.60	\$17.57	\$0.00	\$68.10

For apprentice rates see "Apprentice- LABORER (Heavy and Highway)"

PLUMBERS & GASFITTERS <i>PLUMBERS &amp; GASFITTERS LOCAL 12</i>	03/01/2021	\$60.19	\$13.57	\$17.26	\$0.00	\$91.02
--	------------	---------	---------	---------	--------	---------

**Apprentice - PLUMBER/GASFITTER - Local 12**

**Effective Date - 03/01/2021**

Step	percent	Apprentice Base Wage	Health	Pension	Supplemental Unemployment	Total Rate
1	35	\$21.07	\$13.57	\$6.24	\$0.00	\$40.88
2	40	\$24.08	\$13.57	\$7.08	\$0.00	\$44.73
3	55	\$33.10	\$13.57	\$9.63	\$0.00	\$56.30
4	65	\$39.12	\$13.57	\$11.33	\$0.00	\$64.02
5	75	\$45.14	\$13.57	\$13.03	\$0.00	\$71.74

**Notes:**

\*\* 1:2; 2:6; 3:10; 4:14; 5:19/Steps are 1 yr

Step4 with lic\$67.89, Step5 with lic\$75.59

**Apprentice to Journeyworker Ratio:\*\***

PNEUMATIC CONTROLS (TEMP.) <i>PIPEFITTERS LOCAL 537</i>	03/01/2021	\$57.94	\$11.70	\$20.24	\$0.00	\$89.88
--	------------	---------	---------	---------	--------	---------

For apprentice rates see "Apprentice- PIPEFITTER" or "PLUMBER/PIPEFITTER"

Classification	Effective Date	Base Wage	Health	Pension	Supplemental Unemployment	Total Rate
PNEUMATIC DRILL/TOOL OPERATOR <i>LABORERS - ZONE 1</i>	06/01/2021	\$40.92	\$8.60	\$17.57	\$0.00	\$67.09
	12/01/2021	\$41.93	\$8.60	\$17.57	\$0.00	\$68.10
	06/01/2022	\$42.93	\$8.60	\$17.57	\$0.00	\$69.10
	12/01/2022	\$43.93	\$8.60	\$17.57	\$0.00	\$70.10
	06/01/2023	\$44.93	\$8.60	\$17.57	\$0.00	\$71.10
	12/01/2023	\$46.18	\$8.60	\$17.57	\$0.00	\$72.35
For apprentice rates see "Apprentice- LABORER"						
PNEUMATIC DRILL/TOOL OPERATOR (HEAVY & HIGHWAY) <i>LABORERS - ZONE 1 (HEAVY &amp; HIGHWAY)</i>	06/01/2021	\$40.92	\$8.60	\$17.57	\$0.00	\$67.09
	12/01/2021	\$41.93	\$8.60	\$17.57	\$0.00	\$68.10
For apprentice rates see "Apprentice- LABORER (Heavy and Highway)"						
POWDERMAN & BLASTER <i>LABORERS - ZONE 1</i>	06/01/2021	\$41.67	\$8.60	\$17.57	\$0.00	\$67.84
	12/01/2021	\$42.68	\$8.60	\$17.57	\$0.00	\$68.85
	06/01/2022	\$43.68	\$8.60	\$17.57	\$0.00	\$69.85
	12/01/2022	\$44.68	\$8.60	\$17.57	\$0.00	\$70.85
	06/01/2023	\$45.68	\$8.60	\$17.57	\$0.00	\$71.85
	12/01/2023	\$46.93	\$8.60	\$17.57	\$0.00	\$73.10
For apprentice rates see "Apprentice- LABORER"						
POWDERMAN & BLASTER (HEAVY & HIGHWAY) <i>LABORERS - ZONE 1 (HEAVY &amp; HIGHWAY)</i>	06/01/2021	\$41.67	\$8.60	\$17.57	\$0.00	\$67.84
	12/01/2021	\$42.68	\$8.60	\$17.57	\$0.00	\$68.85
For apprentice rates see "Apprentice- LABORER (Heavy and Highway)"						
POWER SHOVEL/DERRICK/TRENCHING MACHINE <i>OPERATING ENGINEERS LOCAL 4</i>	06/01/2021	\$50.73	\$13.75	\$15.80	\$0.00	\$80.28
	12/01/2021	\$51.88	\$13.75	\$15.80	\$0.00	\$81.43
For apprentice rates see "Apprentice- OPERATING ENGINEERS"						
PUMP OPERATOR (CONCRETE) <i>OPERATING ENGINEERS LOCAL 4</i>	06/01/2021	\$50.73	\$13.75	\$15.80	\$0.00	\$80.28
	12/01/2021	\$51.88	\$13.75	\$15.80	\$0.00	\$81.43
For apprentice rates see "Apprentice- OPERATING ENGINEERS"						
PUMP OPERATOR (DEWATERING, OTHER) <i>OPERATING ENGINEERS LOCAL 4</i>	06/01/2021	\$33.40	\$13.75	\$15.80	\$0.00	\$62.95
	12/01/2021	\$34.19	\$13.75	\$15.80	\$0.00	\$63.74
For apprentice rates see "Apprentice- OPERATING ENGINEERS"						
READY MIX CONCRETE DRIVERS after 4/30/12 (Drivers Hired After 4/30/2012) <i>TEAMSTERS 25 (Metro) - Aggregate</i>	05/01/2021	\$29.15	\$10.91	\$15.25	\$0.00	\$55.31
	08/01/2021	\$29.15	\$11.41	\$15.25	\$0.00	\$55.81
	05/01/2022	\$30.40	\$11.41	\$15.25	\$0.00	\$57.06
	08/01/2022	\$30.40	\$11.91	\$15.25	\$0.00	\$57.56
READY-MIX CONCRETE DRIVER <i>TEAMSTERS 25 (Metro) - Aggregate</i>	05/01/2021	\$33.66	\$10.91	\$15.25	\$0.00	\$59.82
	08/01/2021	\$33.66	\$11.41	\$15.25	\$0.00	\$60.32
	05/01/2022	\$34.41	\$11.41	\$15.25	\$0.00	\$61.07
	08/01/2022	\$34.41	\$11.91	\$15.25	\$0.00	\$61.57
RECLAIMERS <i>OPERATING ENGINEERS LOCAL 4</i>	06/01/2021	\$50.19	\$13.75	\$15.80	\$0.00	\$79.74
	12/01/2021	\$51.33	\$13.75	\$15.80	\$0.00	\$80.88
For apprentice rates see "Apprentice- OPERATING ENGINEERS"						
RIDE-ON MOTORIZED BUGGY OPERATOR <i>LABORERS - ZONE 1</i>	06/01/2021	\$40.92	\$8.60	\$17.57	\$0.00	\$67.09
	12/01/2021	\$41.93	\$8.60	\$17.57	\$0.00	\$68.10
	06/01/2022	\$42.93	\$8.60	\$17.57	\$0.00	\$69.10
	12/01/2022	\$43.93	\$8.60	\$17.57	\$0.00	\$70.10
	06/01/2023	\$44.93	\$8.60	\$17.57	\$0.00	\$71.10
	12/01/2023	\$46.18	\$8.60	\$17.57	\$0.00	\$72.35
For apprentice rates see "Apprentice- LABORER"						

Classification	Effective Date	Base Wage	Health	Pension	Supplemental Unemployment	Total Rate
ROLLER/SPREADER/MULCHING MACHINE <i>OPERATING ENGINEERS LOCAL 4</i>	06/01/2021	\$50.19	\$13.75	\$15.80	\$0.00	\$79.74
	12/01/2021	\$51.33	\$13.75	\$15.80	\$0.00	\$80.88
For apprentice rates see "Apprentice- OPERATING ENGINEERS"						
ROOFER (Inc.Roofing Waterproofing &Roofing Damproofg) <i>ROOFERS LOCAL 33</i>	02/01/2021	\$46.60	\$12.28	\$17.15	\$0.00	\$76.03
	08/01/2021	\$48.03	\$12.28	\$17.15	\$0.00	\$77.46
	02/01/2022	\$49.46	\$12.28	\$17.15	\$0.00	\$78.89

**Apprentice - ROOFER - Local 33**

**Effective Date - 02/01/2021**

Step	percent	Apprentice Base Wage	Health	Pension	Supplemental Unemployment	Total Rate
1	50	\$23.30	\$12.28	\$4.31	\$0.00	\$39.89
2	60	\$27.96	\$12.28	\$17.15	\$0.00	\$57.39
3	65	\$30.29	\$12.28	\$17.15	\$0.00	\$59.72
4	75	\$34.95	\$12.28	\$17.15	\$0.00	\$64.38
5	85	\$39.61	\$12.28	\$17.15	\$0.00	\$69.04

**Effective Date - 08/01/2021**

Step	percent	Apprentice Base Wage	Health	Pension	Supplemental Unemployment	Total Rate
1	50	\$24.02	\$12.28	\$4.31	\$0.00	\$40.61
2	60	\$28.82	\$12.28	\$17.15	\$0.00	\$58.25
3	65	\$31.22	\$12.28	\$17.15	\$0.00	\$60.65
4	75	\$36.02	\$12.28	\$17.15	\$0.00	\$65.45
5	85	\$40.83	\$12.28	\$17.15	\$0.00	\$70.26

**Notes:** \*\* 1:5, 2:6-10, the 1:10; Reroofing: 1:4, then 1:1  
 Step 1 is 2000 hrs.; Steps 2-5 are 1000 hrs.  
 (Hot Pitch Mechanics' receive \$1.00 hr. above ROOFER)

**Apprentice to Journeyworker Ratio:\*\***

ROOFER SLATE / TILE / PRECAST CONCRETE <i>ROOFERS LOCAL 33</i>	02/01/2021	\$46.85	\$12.28	\$17.15	\$0.00	\$76.28
	08/01/2021	\$48.28	\$12.28	\$17.15	\$0.00	\$77.71
	02/01/2022	\$49.71	\$12.28	\$17.15	\$0.00	\$79.14
For apprentice rates see "Apprentice- ROOFER"						
SHEETMETAL WORKER <i>SHEETMETAL WORKERS LOCAL 17 - A</i>	02/01/2021	\$51.67	\$13.65	\$24.57	\$2.70	\$92.59
	08/01/2021	\$53.42	\$13.65	\$24.57	\$2.75	\$94.39
	02/01/2022	\$55.17	\$13.65	\$24.57	\$2.80	\$96.19

**Classification**

**Effective Date    Base Wage    Health    Pension    Supplemental Unemployment    Total Rate**

**Apprentice - SHEET METAL WORKER - Local 17-A**

**Effective Date - 02/01/2021**

Step	percent	Apprentice Base Wage	Health	Pension	Supplemental Unemployment	Total Rate
1	42	\$21.70	\$13.65	\$5.89	\$0.00	\$41.24
2	42	\$21.70	\$13.65	\$5.89	\$0.00	\$41.24
3	47	\$24.28	\$13.65	\$11.13	\$1.48	\$50.54
4	47	\$24.28	\$13.65	\$11.13	\$1.48	\$50.54
5	52	\$26.87	\$13.65	\$12.08	\$1.58	\$54.18
6	52	\$26.87	\$13.65	\$12.33	\$1.59	\$54.44
7	60	\$31.00	\$13.65	\$13.70	\$1.76	\$60.11
8	65	\$33.59	\$13.65	\$14.65	\$1.88	\$63.77
9	75	\$38.75	\$13.65	\$16.56	\$2.08	\$71.04
10	85	\$43.92	\$13.65	\$17.96	\$2.28	\$77.81

**Effective Date - 08/01/2021**

Step	percent	Apprentice Base Wage	Health	Pension	Supplemental Unemployment	Total Rate
1	42	\$22.44	\$13.65	\$5.89	\$0.00	\$41.98
2	42	\$22.44	\$13.65	\$5.89	\$0.00	\$41.98
3	47	\$25.11	\$13.65	\$11.13	\$1.48	\$51.37
4	47	\$25.11	\$13.65	\$11.13	\$1.48	\$51.37
5	52	\$27.78	\$13.65	\$12.08	\$1.58	\$55.09
6	52	\$27.78	\$13.65	\$12.33	\$1.59	\$55.35
7	60	\$32.05	\$13.65	\$13.70	\$1.76	\$61.16
8	65	\$34.72	\$13.65	\$14.65	\$1.88	\$64.90
9	75	\$40.07	\$13.65	\$16.56	\$2.08	\$72.36
10	85	\$45.41	\$13.65	\$17.96	\$2.28	\$79.30

**Notes:**  
Steps are 6 mos.

**Apprentice to Journeyworker Ratio:1:4**

SPECIALIZED EARTH MOVING EQUIP < 35 TONS <i>TEAMSTERS JOINT COUNCIL NO. 10 ZONE A</i>	06/01/2021	\$37.34	\$12.91	\$14.82	\$0.00	\$65.07
	08/01/2021	\$37.34	\$13.41	\$14.82	\$0.00	\$65.57
	12/01/2021	\$37.34	\$13.41	\$16.01	\$0.00	\$66.76
SPECIALIZED EARTH MOVING EQUIP > 35 TONS <i>TEAMSTERS JOINT COUNCIL NO. 10 ZONE A</i>	06/01/2021	\$37.63	\$12.91	\$14.82	\$0.00	\$65.36
	08/01/2021	\$37.63	\$13.41	\$14.82	\$0.00	\$65.86
	12/01/2021	\$37.63	\$13.41	\$16.01	\$0.00	\$67.05
SPRINKLER FITTER <i>SPRINKLER FITTERS LOCAL 550 - (Section A) Zone 1</i>	03/01/2021	\$62.45	\$10.00	\$21.25	\$0.00	\$93.70



**Classification**

**Effective Date    Base Wage    Health    Pension    Supplemental Unemployment    Total Rate**

**Apprentice - SPRINKLER FITTER - Local 550 (Section A) Zone 1**

**Effective Date - 03/01/2021**

Step	percent	Apprentice Base Wage	Health	Pension	Supplemental Unemployment	Total Rate
1	35	\$21.86	\$10.00	\$11.99	\$0.00	\$43.85
2	40	\$24.98	\$10.00	\$12.70	\$0.00	\$47.68
3	45	\$28.10	\$10.00	\$13.41	\$0.00	\$51.51
4	50	\$31.23	\$10.00	\$14.13	\$0.00	\$55.36
5	55	\$34.35	\$10.00	\$14.84	\$0.00	\$59.19
6	60	\$37.47	\$10.00	\$15.55	\$0.00	\$63.02
7	65	\$40.59	\$10.00	\$16.26	\$0.00	\$66.85
8	70	\$43.72	\$10.00	\$16.98	\$0.00	\$70.70
9	75	\$46.84	\$10.00	\$17.69	\$0.00	\$74.53
10	80	\$49.96	\$10.00	\$18.40	\$0.00	\$78.36

**Notes:** Apprentice entered prior 9/30/10:  
40/45/50/55/60/65/70/75/80/85  
Steps are 850 hours

**Apprentice to Journeyworker Ratio:1:3**

<b>STEAM BOILER OPERATOR</b> <i>OPERATING ENGINEERS LOCAL 4</i>	06/01/2021	\$50.19	\$13.75	\$15.80	\$0.00	\$79.74
	12/01/2021	\$51.33	\$13.75	\$15.80	\$0.00	\$80.88
For apprentice rates see "Apprentice- OPERATING ENGINEERS"						
<b>TAMPERS, SELF-PROPELLED OR TRACTOR DRAWN</b> <i>OPERATING ENGINEERS LOCAL 4</i>	06/01/2021	\$50.19	\$13.75	\$15.80	\$0.00	\$79.74
	12/01/2021	\$51.33	\$13.75	\$15.80	\$0.00	\$80.88
For apprentice rates see "Apprentice- OPERATING ENGINEERS"						
<b>TELECOMMUNICATION TECHNICIAN</b> <i>ELECTRICIANS LOCAL 103</i>	03/01/2021	\$42.11	\$13.00	\$17.88	\$0.00	\$72.99
	09/01/2021	\$43.77	\$13.00	\$18.00	\$0.00	\$74.77
	03/01/2022	\$45.27	\$13.00	\$18.12	\$0.00	\$76.39
	09/01/2022	\$46.99	\$13.00	\$18.24	\$0.00	\$78.23
	03/01/2023	\$48.54	\$13.00	\$18.37	\$0.00	\$79.91

**Apprentice - TELECOMMUNICATION TECHNICIAN - Local 103**

**Effective Date - 03/01/2021**

Step	percent	Apprentice Base Wage	Health	Pension	Supplemental Unemployment	Total Rate
1	45	\$18.95	\$13.00	\$0.57	\$0.00	\$32.52
2	45	\$18.95	\$13.00	\$0.57	\$0.00	\$32.52
3	50	\$21.06	\$13.00	\$14.51	\$0.00	\$48.57
4	50	\$21.06	\$13.00	\$14.51	\$0.00	\$48.57
5	55	\$23.16	\$13.00	\$14.84	\$0.00	\$51.00
6	60	\$25.27	\$13.00	\$15.18	\$0.00	\$53.45
7	65	\$27.37	\$13.00	\$15.52	\$0.00	\$55.89
8	70	\$29.48	\$13.00	\$15.85	\$0.00	\$58.33
9	75	\$31.58	\$13.00	\$16.20	\$0.00	\$60.78
10	80	\$33.69	\$13.00	\$16.53	\$0.00	\$63.22

**Effective Date - 09/01/2021**

Step	percent	Apprentice Base Wage	Health	Pension	Supplemental Unemployment	Total Rate
1	45	\$19.70	\$13.00	\$0.59	\$0.00	\$33.29
2	45	\$19.70	\$13.00	\$0.59	\$0.00	\$33.29
3	50	\$21.89	\$13.00	\$14.57	\$0.00	\$49.46
4	50	\$21.89	\$13.00	\$14.57	\$0.00	\$49.46
5	55	\$24.07	\$13.00	\$14.91	\$0.00	\$51.98
6	60	\$26.26	\$13.00	\$15.26	\$0.00	\$54.52
7	65	\$28.45	\$13.00	\$15.59	\$0.00	\$57.04
8	70	\$30.64	\$13.00	\$15.94	\$0.00	\$59.58
9	75	\$32.83	\$13.00	\$16.28	\$0.00	\$62.11
10	80	\$35.02	\$13.00	\$16.63	\$0.00	\$64.65

**Notes:**

**Apprentice to Journeyworker Ratio:1:1**

TERRAZZO FINISHERS	02/01/2021	\$54.69	\$11.39	\$22.09	\$0.00	\$88.17
BRICKLAYERS LOCAL 3 - MARBLE & TILE	08/01/2021	\$56.09	\$11.39	\$22.25	\$0.00	\$89.73
	02/01/2022	\$56.68	\$11.39	\$22.25	\$0.00	\$90.32

**Classification**

**Effective Date   Base Wage   Health   Pension   Supplemental Unemployment   Total Rate**

**Apprentice - TERRAZZO FINISHER - Local 3 Marble & Tile**

**Effective Date - 02/01/2021**

Step	percent	Apprentice Base Wage	Health	Pension	Supplemental Unemployment	Total Rate
1	50	\$27.35	\$11.39	\$22.09	\$0.00	\$60.83
2	60	\$32.81	\$11.39	\$22.09	\$0.00	\$66.29
3	70	\$38.28	\$11.39	\$22.09	\$0.00	\$71.76
4	80	\$43.75	\$11.39	\$22.09	\$0.00	\$77.23
5	90	\$49.22	\$11.39	\$22.09	\$0.00	\$82.70

**Effective Date - 08/01/2021**

Step	percent	Apprentice Base Wage	Health	Pension	Supplemental Unemployment	Total Rate
1	50	\$28.05	\$11.39	\$22.25	\$0.00	\$61.69
2	60	\$33.65	\$11.39	\$22.25	\$0.00	\$67.29
3	70	\$39.26	\$11.39	\$22.25	\$0.00	\$72.90
4	80	\$44.87	\$11.39	\$22.25	\$0.00	\$78.51
5	90	\$50.48	\$11.39	\$22.25	\$0.00	\$84.12

**Notes:**

**Apprentice to Journeyworker Ratio:1:3**

TEST BORING DRILLER <i>LABORERS - FOUNDATION AND MARINE</i>	06/01/2021	\$42.07	\$8.60	\$17.72	\$0.00	\$68.39
	12/01/2021	\$43.08	\$8.60	\$17.72	\$0.00	\$69.40
For apprentice rates see "Apprentice- LABORER"						
TEST BORING DRILLER HELPER <i>LABORERS - FOUNDATION AND MARINE</i>	06/01/2021	\$40.79	\$8.60	\$17.72	\$0.00	\$67.11
	12/01/2021	\$41.80	\$8.60	\$17.72	\$0.00	\$68.12
For apprentice rates see "Apprentice- LABORER"						
TEST BORING LABORER <i>LABORERS - FOUNDATION AND MARINE</i>	06/01/2021	\$40.67	\$8.60	\$17.72	\$0.00	\$66.99
	12/01/2021	\$41.68	\$8.60	\$17.72	\$0.00	\$68.00
For apprentice rates see "Apprentice- LABORER"						
TRACTORS/PORTABLE STEAM GENERATORS <i>OPERATING ENGINEERS LOCAL 4</i>	06/01/2021	\$50.19	\$13.75	\$15.80	\$0.00	\$79.74
	12/01/2021	\$51.33	\$13.75	\$15.80	\$0.00	\$80.88
For apprentice rates see "Apprentice- OPERATING ENGINEERS"						
TRAILERS FOR EARTH MOVING EQUIPMENT <i>TEAMSTERS JOINT COUNCIL NO. 10 ZONE A</i>	06/01/2021	\$37.92	\$12.91	\$14.82	\$0.00	\$65.65
	08/01/2021	\$37.92	\$13.41	\$14.82	\$0.00	\$66.15
	12/01/2021	\$37.92	\$13.41	\$16.01	\$0.00	\$67.34
TUNNEL WORK - COMPRESSED AIR <i>LABORERS (COMPRESSED AIR)</i>	06/01/2021	\$52.90	\$8.60	\$18.17	\$0.00	\$79.67
	12/01/2021	\$53.91	\$8.60	\$18.17	\$0.00	\$80.68
For apprentice rates see "Apprentice- LABORER"						
TUNNEL WORK - COMPRESSED AIR (HAZ. WASTE) <i>LABORERS (COMPRESSED AIR)</i>	06/01/2021	\$54.90	\$8.60	\$18.17	\$0.00	\$81.67
	12/01/2021	\$55.91	\$8.60	\$18.17	\$0.00	\$82.68
For apprentice rates see "Apprentice- LABORER"						
TUNNEL WORK - FREE AIR <i>LABORERS (FREE AIR TUNNEL)</i>	06/01/2021	\$44.97	\$8.60	\$18.17	\$0.00	\$71.74
	12/01/2021	\$45.98	\$8.60	\$18.17	\$0.00	\$72.75
For apprentice rates see "Apprentice- LABORER"						

Classification	Effective Date	Base Wage	Health	Pension	Supplemental Unemployment	Total Rate
TUNNEL WORK - FREE AIR (HAZ. WASTE) <i>LABORERS (FREE AIR TUNNEL)</i>	06/01/2021	\$46.97	\$8.60	\$18.17	\$0.00	\$73.74
	12/01/2021	\$47.98	\$8.60	\$18.17	\$0.00	\$74.75
For apprentice rates see "Apprentice- LABORER"						
VAC-HAUL <i>TEAMSTERS JOINT COUNCIL NO. 10 ZONE A</i>	06/01/2021	\$37.34	\$12.91	\$14.82	\$0.00	\$65.07
	08/01/2021	\$37.34	\$13.41	\$14.82	\$0.00	\$65.57
	12/01/2021	\$37.34	\$13.41	\$16.01	\$0.00	\$66.76
WAGON DRILL OPERATOR <i>LABORERS - ZONE 1</i>	06/01/2021	\$40.92	\$8.60	\$17.57	\$0.00	\$67.09
	12/01/2021	\$41.93	\$8.60	\$17.57	\$0.00	\$68.10
	06/01/2022	\$42.93	\$8.60	\$17.57	\$0.00	\$69.10
	12/01/2022	\$43.93	\$8.60	\$17.57	\$0.00	\$70.10
	06/01/2023	\$44.93	\$8.60	\$17.57	\$0.00	\$71.10
	12/01/2023	\$46.18	\$8.60	\$17.57	\$0.00	\$72.35
For apprentice rates see "Apprentice- LABORER"						
WAGON DRILL OPERATOR (HEAVY & HIGHWAY) <i>LABORERS - ZONE 1 (HEAVY &amp; HIGHWAY)</i>	06/01/2021	\$40.92	\$8.60	\$17.57	\$0.00	\$67.09
	12/01/2021	\$41.93	\$8.60	\$17.57	\$0.00	\$68.10
For apprentice rates see "Apprentice- LABORER (Heavy and Highway)"						
WASTE WATER PUMP OPERATOR <i>OPERATING ENGINEERS LOCAL 4</i>	06/01/2021	\$50.73	\$13.75	\$15.80	\$0.00	\$80.28
	12/01/2021	\$51.88	\$13.75	\$15.80	\$0.00	\$81.43
For apprentice rates see "Apprentice- OPERATING ENGINEERS"						
WATER METER INSTALLER <i>PLUMBERS &amp; GASFITTERS LOCAL 12</i>	03/01/2021	\$60.19	\$13.57	\$17.26	\$0.00	\$91.02
For apprentice rates see "Apprentice- PLUMBER/PIPEFITTER" or "PLUMBER/GASFITTER"						
<b>Outside Electrical - East</b>						
CABLE TECHNICIAN (Power Zone) <i>OUTSIDE ELECTRICAL WORKERS - EAST LOCAL 104</i>	08/30/2020	\$29.67	\$9.25	\$1.89	\$0.00	\$40.81
For apprentice rates see "Apprentice- LINEMAN"						
CABLEMAN (Underground Ducts & Cables) <i>OUTSIDE ELECTRICAL WORKERS - EAST LOCAL 104</i>	08/30/2020	\$42.03	\$9.25	\$10.27	\$0.00	\$61.55
For apprentice rates see "Apprentice- LINEMAN"						
DRIVER / GROUNDMAN CDL <i>OUTSIDE ELECTRICAL WORKERS - EAST LOCAL 104</i>	08/30/2020	\$34.62	\$9.25	\$10.07	\$0.00	\$53.94
For apprentice rates see "Apprentice- LINEMAN"						
DRIVER / GROUNDMAN -Inexperienced (<2000 Hrs) <i>OUTSIDE ELECTRICAL WORKERS - EAST LOCAL 104</i>	08/30/2020	\$27.20	\$9.25	\$1.82	\$0.00	\$38.27
For apprentice rates see "Apprentice- LINEMAN"						
EQUIPMENT OPERATOR (Class A CDL) <i>OUTSIDE ELECTRICAL WORKERS - EAST LOCAL 104</i>	08/30/2020	\$42.03	\$9.25	\$14.35	\$0.00	\$65.63
For apprentice rates see "Apprentice- LINEMAN"						
EQUIPMENT OPERATOR (Class B CDL) <i>OUTSIDE ELECTRICAL WORKERS - EAST LOCAL 104</i>	08/30/2020	\$37.09	\$9.25	\$10.87	\$0.00	\$57.21
For apprentice rates see "Apprentice- LINEMAN"						
GROUNDMAN <i>OUTSIDE ELECTRICAL WORKERS - EAST LOCAL 104</i>	08/30/2020	\$27.20	\$9.25	\$1.82	\$0.00	\$38.27
For apprentice rates see "Apprentice- LINEMAN"						
GROUNDMAN -Inexperienced (<2000 Hrs.) <i>OUTSIDE ELECTRICAL WORKERS - EAST LOCAL 104</i>	08/30/2020	\$22.25	\$9.25	\$1.82	\$0.00	\$33.32
For apprentice rates see "Apprentice- LINEMAN"						
JOURNEYMAN LINEMAN <i>OUTSIDE ELECTRICAL WORKERS - EAST LOCAL 104</i>	08/30/2020	\$49.45	\$9.25	\$17.48	\$0.00	\$76.18

**Classification**

**Effective Date    Base Wage    Health    Pension    Supplemental Unemployment    Total Rate**

**Apprentice - LINEMAN (Outside Electrical) - East Local 104**

**Effective Date - 08/30/2020**

Step	percent	Apprentice Base Wage	Health	Pension	Supplemental Unemployment	Total Rate
1	60	\$29.67	\$9.25	\$3.39	\$0.00	\$42.31
2	65	\$32.14	\$9.25	\$3.46	\$0.00	\$44.85
3	70	\$34.62	\$9.25	\$3.54	\$0.00	\$47.41
4	75	\$37.09	\$9.25	\$5.11	\$0.00	\$51.45
5	80	\$39.56	\$9.25	\$5.19	\$0.00	\$54.00
6	85	\$42.03	\$9.25	\$5.26	\$0.00	\$56.54
7	90	\$44.51	\$9.25	\$7.34	\$0.00	\$61.10

**Notes:**

**Apprentice to Journeyworker Ratio:1:2**

TELEDATA CABLE SPLICER <i>OUTSIDE ELECTRICAL WORKERS - EAST LOCAL 104</i>	02/04/2019	\$30.73	\$4.70	\$3.17	\$0.00	\$38.60
TELEDATA LINEMAN/EQUIPMENT OPERATOR <i>OUTSIDE ELECTRICAL WORKERS - EAST LOCAL 104</i>	02/04/2019	\$28.93	\$4.70	\$3.14	\$0.00	\$36.77
TELEDATA WIREMAN/INSTALLER/TECHNICIAN <i>OUTSIDE ELECTRICAL WORKERS - EAST LOCAL 104</i>	02/04/2019	\$28.93	\$4.70	\$3.14	\$0.00	\$36.77

**Additional Apprentice Information:**

Minimum wage rates for apprentices employed on public works projects are listed above as a percentage of the pre-determined hourly wage rate established by the Commissioner under the provisions of the M.G.L. c. 149, ss. 26-27D. Apprentice ratios are established by the Division of Apprenticeship Training pursuant to M.G.L. c. 23, ss. 11E-11L.

All apprentices must be registered with the Division of Apprenticeship Training in accordance with M.G.L. c. 23, ss. 11E-11L.

All steps are six months (1000 hours.)

Ratios are expressed in allowable number of apprentices to journeymen or fraction thereof, unless otherwise specified.

\*\* Multiple ratios are listed in the comment field.

\*\*\* APP to JM; 1:1, 2:2, 2:3, 3:4, 4:4, 4:5, 4:6, 5:7, 6:7, 6:8, 6:9, 7:10, 8:10, 8:11, 8:12, 9:13, 10:13, 10:14, etc.

\*\*\*\* APP to JM; 1:1, 1:2, 2:3, 2:4, 3:5, 4:6, 4:7, 5:8, 6:9, 6:10, 7:11, 8:12, 8:13, 9:14, 10:15, 10:16, etc.