

BID #22-  
39

2022 LEAD WATER SERVICE  
REPLACEMENT PROJECT - VARIOUS  
LOCATIONS

Town of Arlington, Massachusetts  
Department of Public Works  
51 Grove Street

Arlington, MA 02476



## Table of Contents

Table of Contents .....	iii
I. Invitation for Bid .....	1
II. Instruction to Bidders .....	3
A. Receipt of Bids .....	3
B. Preparation of Bid .....	3
C. Bid Security .....	3
D. Time of Completion .....	4
E. Performance and Labor Material Bonds.....	4
F. Laws and Regulations.....	4
G. Withdrawal of Bids.....	4
H. Execution of Contract.....	4
I. Obligation of Bidder .....	5
J. Omissions, Discrepancies, Interpretations and Addenda .....	5
K. Record of Address .....	5
L. Massachusetts Sales and Use Tax .....	5
M. State Tax Affidavit .....	5
N. Minimum Wage Rates.....	5
O. Sub-bids.....	6
P. Supplemental Information .....	6
III. Proposal .....	7
BID SHEET .....	8
BID SUMMARY .....	9
A. Financial Statement .....	11
B. Bidders Experience Record .....	11
C. Certification of Tax Compliance .....	13
D. CERTIFICATE OF NON-COLLUSION .....	14
IV. Contract.....	15
A. Definitions .....	15
B. Parts of Contract .....	15
C. Obligations of the Contractor .....	15

- D. Liability of the Contractor ..... 15
- E. Authority of the Engineer ..... 16
- F. Engineer to Decide..... 16
- G. Time for Commencing Work ..... 16
- H. No Damages for Certain Delays ..... 17
- I. Time for Completion ..... 17
- J. Competent Persons to be Employed ..... 17
- K. Access to Work..... 18
- L. Defective Work, Materials or Equipment ..... 18
- M. Mistakes of Contractor ..... 18
- N. Discrepancies, Errors and Omissions ..... 18
- O. Right to Materials..... 19
- P. Compliance with Laws, Ordinances, and Regulations ..... 19
- Q. Provisions Required by Law Deemed Inserted ..... 19
- R. Work Hours ..... 19
- S. Intoxicating Liquors..... 20
- T. Permits and Notices ..... 20
- U. Patents ..... 20
- V. Insurance..... 20
- W. Work Not to be Sublet or Assigned..... 21
- X. Alterations..... 21
- Y. Extra Work ..... 21
- Z. Extension of Time on Account of Extra Work ..... 22
- AA. Changes Not to Affect Bonds ..... 23
- BB. Completion of Work if Contract is Not Fulfilled..... 23
- CC. Compensation for Work..... 24
- DD. Money may be Retained ..... 24
- EE. Estimates and Payments ..... 24
- FF. Partial Payment Not Acceptance ..... 25
- GG. Liens ..... 25
- HH. Waiver ..... 25

II.	Liability of the Town of Arlington .....	25
JJ.	Guarantee .....	26
KK.	Money Retained for Repairs .....	26
LL.	Address of Contractor .....	26
MM.	CERTIFICATE of VOTE .....	28
V.	PERFORMANCE BOND.....	29
VI.	General Conditions .....	31
A.	Definitions.....	31
B.	Abbreviations.....	31
C.	Handling Materials.....	32
D.	Storage Room.....	32
E.	Shop Drawings, Schedules, and Descriptive Matter .....	32
F.	Equivalents.....	32
G.	Materials and Workmanship.....	33
H.	Inspection by the Engineer .....	33
I.	Documents at Site of Work.....	33
J.	Lines and Grades.....	33
K.	Scaffolding and Protection.....	33
L.	Public Safety and Property of Others.....	33
M.	Existing Structures, Pipes, Conduits, Etc.....	34
N.	Sanitary Provisions .....	34
O.	Cutting and Patching.....	34
P.	Management of Debris, Refuse, and Garbage and Site Cleanup.....	34
Q.	Measurement of Quantities.....	35
R.	Compliance with Occupational Safety and Health Act of 1970 .....	35
S.	Order of Precedence Governing Specifications .....	35
T.	Affirmative Action/Anti-Discrimination .....	36
1.	Compliance with Requirements.....	37
2.	Non-Discrimination .....	37
3.	Solicitations for Sub-Contracts, and for the Procurement of Materials and Equipment.....	38
4.	Bidders Certification Requirement .....	38

5.	Contractor’s Certification.....	38
6.	Compliance-Information, Reports and Sanctions.....	38
7.	Severability.....	39
VII.	SPECIAL CONDITIONS.....	40
A.	SCOPE OF SPECIAL CONDITIONS.....	40
B.	MINIMUM LIMITS FOR INSURANCE.....	40
C.	RETAINAGE.....	40
D.	PAYMENT OF SUMS DUE CONTRACTOR.....	40
E.	DISPOSAL OF EXCAVATED MATERIAL.....	40
F.	EXCERPTS FROM CERTAIN LAWS.....	40
G.	REGULATIONS OF THE COMMONWEALTH OF MASSACHUSETTS.....	41
H.	ADJACENT CONTRACTS.....	41
I.	TRAFFIC ORDERS.....	41
J.	TIME FOR COMPLETION AND LIQUIDATED DAMAGES.....	42
K.	RESTORATION OF SURFACE.....	42
L.	PROTECTION OF TREES.....	42
M.	INTERPRETATION OF CONTRACT.....	42
N.	CONTROL OF WATER SYSTEM.....	43
O.	COMMUNITY NOTICES, COORDINATION, AND NO PARKING SIGNS.....	43
P.	AWARD OF CONTRACT.....	43
Q.	WORKSITE DUST CONTROL.....	43
R.	CONSTRUCTION SEQUENCE.....	44
S.	MEASUREMENTS AND PAYMENT.....	44

## I. Invitation for Bid

Sealed bids are invited and will be received by the Town Manager, Town of Arlington, Massachusetts, until **AUGUST 31, 2022, AT 10:00AM** at the Office of the Purchasing Agent, Town Hall, Arlington, Massachusetts 02476, at which time and place they will be publicly opened and read.

A BID DEPOSIT IN THE FORM OF CASH, CERTIFIED CHECK, OR TREASURER'S CHECK, shall accompany every bid. The amount of such bid deposit shall be FIVE PERCENT (5%) of the value of the bid.

Specifications and proposal forms will be available on the Town of Arlington's purchasing web site (<http://www.arlingtonma.gov/departments/purchasing>) or at the Office of the Purchasing Agent, Town Hall, Arlington, Massachusetts. All bids must be in sealed envelopes plainly marked:

### **Bid On: 2022 Lead Water Service Replacement Project – Various Locations**

The conditions of employment as set forth in Sections 26 to 27D and 27F of Chapter 149 of the General Laws, as amended, shall prevail in the execution of the work under this contract.

Attention is called to the fact that minimum wage rates and health, welfare, and pension fund contributions are established for this contract and are a part of the specifications.

The conditions of employment as set forth in Federal Wage Determination MA20220022 dated August 5, 2022, issued by the U.S. Department of Labor, shall prevail in the execution of the work under this contract. Attention is called to the fact that minimum wage rates and health and welfare and pension fund contributions are established for this contract and are part of the specifications.

Project Partially funded by American Rescue Plan Funds (ARPA), Federal Guidelines Apply.

Work under this contract shall be governed by M.G.L. Ch.30, Sec. 39M.

Attestation Forms pursuant to M.G.L. Ch. 62C, Sec. 49A and M.G.L. Ch. 701 of the Acts of 1983 are enclosed and shall be submitted with bids.

Proposals are for replacing lead water service lines in various locations in the Town of Arlington, MA.

Pre-Bid questions shall be submitted in writing via email to DPW Engineer Ahmet Caus ([acaus@town.arlington.ma.us](mailto:acaus@town.arlington.ma.us)) by **AUGUST 24, 2022, AT 10:00 AM**.

**It is the intention of the Owner to award the Contract to the lowest qualified responsive bidder. The bidder must submit a bid on all bid items in the Contract.**

All proposals to include prices both written and in figures, and must be signed by the bidder with their business address.

An increase or decrease in the quantity of work shall not be regarded as a sufficient ground for an increase in the unit prices.

To receive consideration, bids must be in the hands of the Purchasing Agent or their authorized representative not later than the day and hour *above* mentioned. For further information relative to this bid, please confer with Domenic R. Lanzillotti, Director, Purchasing Department, Town Hall, Arlington, Massachusetts, 02476.

OSHA Construction Training Required: As of July 1, 2006, under M.G.L. Chapter 30, Section 39s, any person, submitting a bid for, or signing a contract to work on, the construction, reconstruction, alteration, remodeling or repair of any public work by the Commonwealth of Massachusetts/Town of Arlington, and estimated by the awarding Authority to cost more than \$10,000, shall certify on the Bid or Contract, under penalty of perjury, that all employees to be employed at the work will have successfully completed a course in construction safety and health approved by the United States Occupational Safety and Health Administration that is at least 10 hours in

The Town Manager reserves the right to cancel any invitation for bids, to reject in whole or in part any and all bids, when it is deemed in the best interest of the Town of Arlington to do so.

By-Law of the Town of Arlington, Title 1, Article 16, Minority/Woman Workforce Participation in Construction Projects which exceeds \$200,000.00 is part and parcel of the bid.

TOWN OF ARLINGTON

Sandy Pooler  
Town Manager  
Date: August 10, 2022

---



## II. Instruction to Bidders

### A. Receipt of Bids

The Town may consider informal any bid not prepared and submitted in accordance with the provisions hereof and may waive any informality in or reject any bids. Any bid may be withdrawn before the time for the opening of bids. Any bid received after the time and date specified shall not be considered. No bidder may withdraw their bid for a period of 30 days, excluding Saturdays, Sundays, and legal holidays after actual date of the opening thereof.

### B. Preparation of Bid

Each bid shall be submitted on the forms attached to these documents. The bid forms may be removed and submitted separately from the other documents. All blank spaces for bid prices must be filled in with the unit price for the item or the lump sum for which the proposal is made. Bidders must bid on each item. All entries in the entire proposal must be made clearly, and prices written in both words and figures in the spaces provided.

Each bid must be in a sealed envelope addressed to the Office of the Purchasing Agent, 730 Massachusetts Avenue, Arlington, Massachusetts, 02476; and bearing on the outside the name of the bidder, their address, the name of the project for which the bid is submitted, and the notation **Bid On: 2022 Lead Water Service Replacement Project – Various Locations**

### C. Bid Security

Every bid submitted by contractors shall be accompanied by a bid deposit in the form of cash, certified check, treasurer's or cashier's check, or a bid bond issued by a responsible bank or trust company and made payable to the Town of Arlington. The amount of the bid deposit shall be 5% of the amount of the bid. All security except those of the three lowest responsible and eligible bidders will be returned within ten days, Saturdays, Sundays, and legal holidays excluded, after opening of the bid. All bid securities will be returned on the execution of the contract or if no award is made within 30 days, excluding Saturdays, Sundays, and legal holidays, after the actual date of the opening thereof, unless forfeited under the conditions herein stipulated.

In case a party to whom a contract is awarded shall fail or neglect to execute the contract and furnish the satisfactory bond in the time specified, the Town may determine the bidder has abandoned the contract and thereupon the proposal and acceptance shall be null and void, and the bid security accompanying the proposal shall be forfeited to the Town as liquidation damages for such failure or neglect and indemnify the Town for any loss which may be sustained by failure of the bidder to execute the contract and furnish the bonds as aforesaid, provided that, in case of death, disability, or other unforeseen circumstances affecting the bidder, such bid security may be returned to them.

After execution of the contract and acceptance of the bonds by the Town, the bid security accompanying the proposal of the successful bidder will be returned.

**D. Time of Completion**

The bidder must agree to commence work within thirty (30) business days from the date of signing the contract and to fully complete the project within the time specified within the Special Provisions section of this document.

**E. Performance and Labor Material Bonds**

A bond in the sum of 50% of the total amount of the Contract by the successful bidder and an additional bond in equal amount covering the payment for all labor and materials used in the work will be required. A surety company authorized to do business in Massachusetts and satisfactory to the Town of Arlington must provide these bonds. These bonds will be required at the execution of the contract. Attorneys-in-fact who sign contract bonds must file with each bond a certified and effectively dated copy of their power of attorney.

**F. Laws and Regulations**

The bidder's attention is directed to the fact that all applicable State laws, Town of Arlington Bylaws, municipal ordinances, and the rules and regulations of all authorities having jurisdiction over construction of the project shall apply to the contract throughout, and they shall be deemed to be included in the contract the same as though herein written out in full.

**G. Withdrawal of Bids**

Upon proper written request and identification, Bids may be withdrawn only as follows:

1. At any time before the designated time for the opening of Bids.
2. Death or serious injury of a principal.
3. With the written approval of the Town of Arlington Office of the Purchasing Director.
4. At any time after the expiration of the period during which withdrawal is prohibited, provided the bid has not been accepted by the Town.

**H. Execution of Contract**

The party to whom the contract is awarded shall be required to execute the contract and furnish the bonds duly executed with a satisfactory surety company within 10 days, excluding Saturdays, Sundays, and legal holidays, of the date of the mailing of the notice to the bidder according to the address given by them, that the contract is ready for execution.

**I. Obligation of Bidder**

At the time of the opening of bids, each bidder shall be presumed to have read and to be thoroughly familiar with the contract documents. The failure or omission of any bidder to receive or examine any form, instrument, or documents shall in no way relieve any bidder from the obligation in respect to their bid.

**J. Omissions, Discrepancies, Interpretations and Addenda**

Should a bidder find discrepancies in, or omissions from, the drawings or contract documents, or should they have questions as to the interpretation of the plans or contract documents they shall submit such in writing via email to the Town Engineering Division ([acaus@town.arlington.ma.us](mailto:acaus@town.arlington.ma.us)) and the Director of Purchasing ([dlanzillotti@town.arlington.ma.us](mailto:dlanzillotti@town.arlington.ma.us)) at least five (5) business days before the date herein set for the opening of bids. An interpretation via addendum will be posted to the Town purchasing website and notification sent by email to all registered bidders at the addresses given by them on or about two (2) business days before the opening of bids. Signed copies of all addenda shall be included with the bid; omission of the signed addendum shall be cause for rejection of the bid.

**K. Record of Address**

Prospective bidders shall at the time plans and specifications are secured place on file with the Director of Purchasing their address and email address, and are required to make any changes necessary to insure that the record is accurate, complete, and up to date. Prospective bidders shall notify the Director of Purchasing if they do not have an email address.

**L. Massachusetts Sales and Use Tax**

Materials purchased for permanent installation in the work will be exempt from the Massachusetts Sales and Use tax. Each bidder shall consider this exemption in calculating their bid for the work.

**M. State Tax Affidavit**

Prospective bidders are required to certify that all state tax returns have been filed and all state taxes have been paid in order to be eligible to enter into a contract with the Town on this project. The included form is to be used for this purpose and is to be completed and returned as part of the bid and proposal.

**N. Minimum Wage Rates**

Prevailing rates for wages for work performed under this Contract will be as predetermined by the Commissioner of Labor and Industries of the Commonwealth of Massachusetts in accordance with the provisions of Sections 26 to 27D, inclusive, of c.149 of M.G.L. A schedule of the prevailing wages is included in the Minimum Wage Rates Section.

**O. Sub-bids**

No sub bids shall be sought in connection with this Contract.

**P. Supplemental Information**

All bidders shall submit the following supplemental information with a fee proposal:

1. Name, address, and phone number of a minimum of three (3) references that can vouch for the performance of the bidder;
2. Proof of Liability and Worker's Compensation Insurance Coverage;
3. Completed tax attestation form;
4. Bid deposit.

### III. Proposal

For Bid 22-39 – Lead Water Service Replacement Project – Various Locations

To the Town of Arlington, Massachusetts, acting through its Town Manager, the undersigned, as bidder, declares as follows:

- A. The only persons or parties interested in this proposal as principals are named in this proposal;
- B. This proposal is made without collusion with any other person, firm or corporation;
- C. They have carefully examined the location of the proposed work and the annexed proposed form of contract, and the drawings and specifications therein referred to;
- D. This proposal is based solely on their review of the contract documents and own investigation and research, and not in reliance upon any plans, surveys, measurements, dimensions, calculations, estimates, borings, test pits, soundings, or representations of any employee, officer, or agent of the Town;

and the undersigned proposes and agrees that if this proposal is accepted, they will contract with the Town, this Proposal form being part of and included in said contract, to provide all necessary machinery, tools, apparatus and other means of construction and to furnish all the labor, supervision, materials, permits and other requisites not expressly stated, necessary to complete the contract in the manner and time therein prescribed and according to the requirements of the plans and specifications; and that they will take in full payment thereof the following sums to with:

## BID SHEET

ITEM #	ITEM	UNIT	QUANTITY	UNIT PRICE (Figures)	TOTAL PRICE (Figures)
1	Test Pit	CY	200	\$	\$
2	Rock/Ledge Excavation	CY	15	\$	\$
3	3/4" Copper Tubing	LF	800	\$	\$
4	3/4" Corporation Stop	EA	20	\$	\$
5	3/4" Curb Stop and Curb Box	EA	20	\$	\$
6	1" Copper Tubing	LF	250	\$	\$
7	1" Corporation Stop	EA	5	\$	\$
8	1" Curb Stop and Curb Box	EA	5	\$	\$
9	Curb Box Replacement Only	EA	15	\$	\$
10	Abandon Existing Service	EA	10	\$	\$
11	Connection to Meter	EA	20	\$	\$
12	Sewer Repair	EA	5	\$	\$
13	Drain Repair	EA	5	\$	\$
14	4" HMA Trench Paving	TONS	120	\$	\$
15	In Kind Sidewalk Replacement	SY	100	\$	\$
16	Loam and Seed	SY	100	\$	\$

Bidder: \_\_\_\_\_

**BID SUMMARY**

Bidder: \_\_\_\_\_

Bid – 2022 Lead Water Service Replacement Project – Various Locations

Total in Figures: \_\_\_\_\_

Total in Words: \_\_\_\_\_

\_\_\_\_\_

The above estimated quantities are an approximate statement of the extent of the work to be done; the Town does not expressly or by implication agree that the actual amount of work will correspond therewith but reserves the right to increase or decrease the amount of any class or portion of the work or to delete certain items of work, as may be deemed necessary, to keep within available funds.

The undersigned as bidder, agrees that for extra work, if any, they will accept compensation as stipulated in the annexed form of CONTRACT.

If this proposal shall be accepted by the Town, and the undersigned shall fail to execute the contract for the work and deliver same to the Town, together with the duly executed Performance Bond and Labor and Material Payment Bond, with sureties satisfactory to the Town, within ten (10) days from the date of mailing of a notice from the Town to them at the address herein given that the proposed contract is ready for execution, then the Town at its option may determine that the undersigned has abandoned the said contract and thereupon if it so determines, the bid security accompanying this proposal shall become the property of the Town as liquidated damages; otherwise the accompanying security shall be returned to the undersigned.

All bidders will be required to show that they have previously completed projects of the same type in a satisfactory manner, namely, the removal of existing water services and the installation of new water services in residential, commercial, and/or otherwise confined areas congested with numerous structures, conduits, high voltage-oil filled electric pipe lines, public and private utility lines, manholes, etc., where careful and time consuming excavation and backfilling is required to protect existing lines and structures.

**The bidder awarded this contract will have to show that they have successfully completed at least three (3) contracts of similar work at a value of \$100,000.00 or more in the previous five (5) years. Completed projects shall be similar in scope and include water service replacement, lead water service replacement, and miscellaneous water main work.**

In addition, if the successful bidder contemplates using sub-contractors, said sub-contractor will be held to the same standards as noted above.

Before starting work, the contractors (includes the general contractor, for itself and its subcontractors, as well as all filed sub-bid contractors) will submit plans for achievement of the equal opportunity goals of the contract. All contractors will be required to make a good faith effort to achieve these goals. The plan will indicate if the contractors expect to achieve the requirements during the first quarter. If there are any reasons why the contractors do not expect to achieve the requirements during the first quarter year of the contract construction phase, then the contractors shall provide a plan calculated to address, to the extent reasonably possible, these obstacles to a good faith effort to achieve such goals.

Not more than ten days following the end of each work quarter, the contractors will report on the achievement of the goals, the detailing the good faith efforts that have been made and will continue to be made and any other appropriate efforts not yet undertaken.



All reports will be signed by an officer or principal of the company who has the authority to contractually obligate the company.

The contractor shall maintain as a goal on this project a not less than five percent ratio of women work force to total project hours in both the general contract and each individual filed sub-bid contract.

A Labor Scheduling Table, which will be used as a tool for achieving a range of women work force participation for the entire project, in both the general contract and each individual filed sub-bid contractor, shall be submitted to the Town.

If the bidder can give the name and address of the surety company that will sign the bonds or state the other security to be offered, they are requested to do so below.

Surety Company Name: \_\_\_\_\_

Address: \_\_\_\_\_

**A. Financial Statement**

The bidder is required to furnish a financial statement and give references that will enable the Town to judge their business standing.

**B. Bidders Experience Record**

The bidder is required to state below, or provide as an attachment, a list of work they have done of a character similar to that work included in the proposed contract and give references that will enable the Town to judge their experience and skill. The bidder awarded this contract will have to show that they have successfully completed at least three (3) contract of similar work at a value of \$100,000.00 or more in the previous five (5) years. Completed projects shall be similar in scope and include water service replacement, lead service replacement, and miscellaneous water main work.

---

---

---

---

---

---

---

---

---

---

**C. Certification of Tax Compliance**

Pursuant to MGL c. 62C, § 49A and requirements of the Town of Arlington, the undersigned acting on behalf of the Contractor certifies under the penalties of perjury that the Contractor is in compliance with all laws of the Commonwealth relating to taxes including payment of all local taxes, fees, assessments, betterments and any other local or municipal charges (unless the Contractor has a pending abatement application or has entered into a payment agreement with the entity to which such charges were owed), reporting of employees and contractors, and withholding and remitting child support.\*

\_\_\_\_\_  
\*\*Signature of Individual or Corporate Contractor

\_\_\_\_\_  
Printed Name

\_\_\_\_\_  
\*\*\*Contractor's Social Security Number or  
Federal Identification Number

\_\_\_\_\_  
Date

\* The provision in this Certification relating to child support applies only when the Contractor is an individual.

\*\* Approval of a contract or other agreement will not be granted until the Town receives a signed copy of this Certification.

\*\*\* Your social security number may be furnished to the Massachusetts Department of Revenue to determine whether you have met tax filing or tax payment obligations. Providers who fail to correct their non-filing or delinquency will not have a contract or other agreement issued, renewed, or extended.

**D. CERTIFICATE OF NON-COLLUSION**

The undersigned certifies under penalties of perjury that this bid or proposal has been made and submitted in good faith and submitted in good faith and without collusion or fraud with any other person. As used in this certification, the word “person” shall mean any natural person, business, partnership, corporation, union, committee club, or other organization, entity, or group or individuals.

---

(Signature of individual)

---

(Name of Business/Corporation)

## **IV. Contract**

### **A. Definitions**

Wherever the word “Town”, “Contractor”, or “Engineer” or pronouns used in place of them occur in this contract, they shall have the following meanings:

The word “Town” shall mean the party of the first part above designated, or any board, office, or agent duly authorized to act for said party of the first part in the matter covered by this contract.

The word “Contractor” shall mean the party of the second part above designated entering into this contract for the performance of the work required, the legal representative of said party, or the agent appointed to act for said party in performance of the work.

The word “Engineer” shall mean the Town Engineer of the Town of Arlington, acting directly or through an authorized representative, acting within the scope of the particular duties entrusted to him.

### **B. Parts of Contract**

It is agreed that the Information for Bidders, the Proposal submitted by the Contractor, the General Conditions, the Special Conditions, the Specifications, the Contract Drawings/Plans, and all Addenda are made parts of this contract.

The table of contents, titles, indexes, and headings contained herein and in said documents are solely to facilitate reference to various provisions of the Contract Documents and in no way affect, limit or cast light on the interpretation of the provisions to which they refer.

### **C. Obligations of the Contractor**

The Contractor shall do all the work and furnish all services, tools, equipment, appliances, and labor necessary, and furnish all materials except as may be otherwise specified herein, necessary or proper for performing and completing the work required by this Contract, with appurtenances of every kind complete in the manner and within the time specified. All work to be performed and materials to be furnished under this contract shall be performed, furnished and completed pursuant to and strictly in conformance with the Contract Drawings, sometimes referred to herein as the “plans”, the attached specifications, and the written directions of the Engineer as given from time to time during the progress of the work. The Contractor shall complete the entire work in accordance with the specifications and drawings herein mentioned and at the prices herein agreed upon and therefore fixed.

### **D. Liability of the Contractor**

The Contractor shall take all responsibility for the work done under this contract, for the protection of the work, and for preventing injuries to persons and damage to property and utilities on or about the work. They shall in no way be relieved of their responsibility by any right of the Engineer to give permission or directions relating to any part of the work, by any such permission or directions given, or by failure of the Engineer to give such permission or direction.

The Contractor shall bear all losses resulting to him or the Town on account of the quantity or character of the work, because the nature of the land in or on which the work is done is different from what was estimated or expected, or on account of the weather, elements, or other causes.

The Contractor shall assume the defense of all claims of whatsoever character against the Contractor or the Town and indemnify and save harmless the Town, its officers, or agents against all claims for injury or damage to persons, corporations, or property arising out of the work done under this contract whether said claims arise out of negligence or not, or whether said claims are groundless, false, or fraudulent or not, and from all claims relating to labor and materials furnished for the work.

The Contractor shall conduct their operations so as not to damage existing structures or work installed either by themselves or by other contractors. In case of any such damage resulting from their operations, they shall repair and make good as new the damaged portions at their own expense with the consent of the damaged party. In the event that consent is not given, the Contractor shall not be relieved thereby of liability for the damage caused. The Contractor shall have no claim against the Town for lost productivity resulting from any such damage.

**E. Authority of the Engineer**

The Engineer shall have the authority to stop the work whenever such stoppage may be necessary in their opinion to prevent improper execution of the work.

The sequence of execution of the work and the general conduct of the work shall be subject to the approval of the Engineer who shall have authority to direct changes be made in such sequence where public necessity or welfare shall require, which approval or direction shall, however, in no way affect the responsibility of the Contractor in the conduct of the work.

Whenever the Contractor is not present on any part of the work where it may be necessary to give directions, such directions may be given by the Engineer and shall be received and obeyed by the superintendent or foreman who may have charge of the particular work involved.

**F. Engineer to Decide**

The Engineer shall make all necessary interpretations as to the meaning and intention of the Contract Drawings, Specifications, and other parts of this Contract. They shall give all orders and directions contemplated therein or thereby, and in every case in which a difficult or unforeseen condition shall arise in the performance of the work required by this contract.

The Engineer shall in all cases determine the amount, quality, acceptability and fitness of the several kinds of work and materials which are to be paid under this contract, and shall decide all questions which may arise as to the fulfillment of this contract. In the event that a determination or decision of the Engineer is questioned by the Contractor, the decision of the Engineer shall be a condition precedent to the Contractor's right to receive any money for the work or materials to which the question or difference in opinion relates.

**G. Time for Commencing Work**

The Contractor shall commence the work within thirty (30) calendar days after signing the contract, or as directed by the Town.

Such time of starting may be postponed by written agreement between the Town and the Contractor because of expected delays in receipt of materials and equipment, if the season is unsuitable for commencement of the work, or because of any other contingency clearly beyond the control or responsibility of the Contractor. Unless stipulated otherwise in said agreement, the Contractor shall commence work at such points as the Engineer may direct

or approve within thirty (30) calendar days after the receipt of a written order from the Town to start work.

#### **H. No Damages for Certain Delays**

The Town may delay the commencement of the work, or any part thereof, for the reason that it has not acquired the necessary land or rights of way, or for any other reason. The Contractor shall have no claim for damages on account of such delay, or on account of any delay on the part of the Town in performing any work or furnishing any materials to the Contractor, or due to extra work required, but they shall be entitled to so much additional time in which to complete the whole or any portion of the work required under this contract. The Contractor shall have no claim for damages on account of any delay on the part of another contractor, but shall have such additional time in which to complete the work.

#### **I. Time for Completion**

The rate of progress shall be such that the whole work shall be performed in accordance with the terms of this contract before the expiration of the time limit stipulated under special conditions, unless and except as any part may be delayed under the provisions of this contract.

It is agreed that the rate of progress herein required has been purposely made long enough to allow for the ordinary delays incident to construction work of this character. No extension of time will be made for ordinary delays, inclement weather, and accidents, and the occurrence of such will not relieve the Contractor from the necessity of maintaining this rate of progress.

If delays are caused by acts of God, acts of Government or State, strikes, extra work, or other contingencies clearly beyond the control or responsibility of the Contractor, the Contractor shall be entitled to so much additional time wherein to perform and complete this contract on their part as the Engineer shall certify in writing to be just.\*

\*This paragraph will be interpreted to include delays in receipt of equipment provided that the Contractor placed their order and submitted shop drawings for such equipment promptly after execution of the contract, that they has shown diligence in following the progress of the order, and that the time required for delivery is in accordance with conditions generally prevailing in the industry.

The time in which this contract is to be performed and completed is of the essence of this agreement.

#### **J. Competent Persons to be Employed**

The Contractor shall have as their agent on the work a competent superintendent capable of reading and thoroughly understanding the drawings and specifications. The superintendent on the work shall have full authority to execute the directions of the Engineer without delay and supply promptly such materials, equipment, tools, labor, and incidentals as may be required.

The Contractor shall employ only competent persons to do the work, and whenever the Engineer shall notify the Contractor in writing that any person on the work is, in their opinion, incompetent, unfaithful, disorderly or otherwise unsatisfactory, such person shall be discharged from the work and shall not again be employed on it accept with the consent of the Engineer.

**K. Access to Work**

The Town, its agents and employees may at all times enter upon the work or premises used by the Contractor, and the Contractor shall provide safe and proper facilities for such entrance and for the inspection of materials, equipment and workmanship.

Other contractors of the Town may also, for the purpose which may be required by their contracts or work, enter upon the work and premises used by the Contractor. Any differences or conflicts which may arise between the Contractor and other contractors of the Town in regard to their work shall be determined and adjusted by the Engineer.

**L. Defective Work, Materials or Equipment**

The inspection of the work shall not relieve the Contractor of any of their obligations to fulfill their contract as herein prescribed, and defective work shall be made good and unsuitable materials or equipment shall be rejected, notwithstanding that such work, and materials or equipment have been previously overlooked by the Engineer and accepted or estimated for payment or paid for. If the work or any part thereof shall be found defective at any time before the final acceptance of the whole work, or the final payment therefore, the Contractor shall forthwith make good such defect, in a manner satisfactory to the Engineer; if any material or equipment brought upon the ground for use in the work, or selected for the same, shall be condemned by the Engineer as unsuitable or not in conformity with the specifications, the Contractor shall forthwith remove such materials or equipment from the vicinity of the work, and any material furnished by the Town which shall be damaged or rendered defective by the handling or improper installation by the Contractor, their agents, or employees shall be made good and replaced at the Contractor's own expense.

**M. Mistakes of Contractor**

The Contractor shall make good any defects, omissions, or mistakes for which they or their employees are responsible, or they shall pay to the Town all expenses, losses, and damages incurred therefrom as determined by the Engineer.

**N. Discrepancies, Errors and Omissions**

The drawings and specifications are intended to be explanatory of each other, but, should any discrepancy appear or any misunderstanding arise as to the import of anything contained in either, the interpretation and decision of the Engineer shall be final and binding on both parties to this contract.

Any correction of errors or omissions in drawings and specifications may be made by the Engineer when such correction is necessary for the proper fulfillment of their intention as construed by him. Where said correction of errors or omissions, except as provided in the next two paragraphs below, adds to the amount of work to be done by the Contractor, compensation for said additional work shall be made under the item for Extra Work, except where the additional work may be classed under some item of work for which a unit price is included in the PROPOSAL.

The fact that specific mention of a fixture or of any part of the work is omitted in the specifications, whether intentionally or otherwise, when the same is clearly indicated on the drawings, or is usually and customarily required to complete fully such work as is specified herein, will not entitle the Contractor to consideration in the matter of any claim



for extra compensation, but said fixtures or work or both shall be installed or done the same as if called for both by the drawings and by the specifications.

All work mentioned in the specifications and not indicated on the drawings, or vice versa, and all work and material usual and necessary to make the work complete in all its parts, whether or not they are mentioned in the specifications, or indicated on the drawings, shall be furnished and executed the same as if they were called for both by the specifications and by the drawings.

**O. Right to Materials**

All materials shall become the property of the Town after they have been affixed or attached to the soil or to the work, and nothing in this contract shall be construed as vesting in the Contractor any right or property in the materials after their being so affixed or attached.

**P. Compliance with Laws, Ordinances, and Regulations**

The Contractor shall keep themselves fully informed of all existing and future State and National laws and municipal ordinances and regulations in any manner affecting those engaged or employed in the work, the materials used in the work, or the conduct of the work, and of all such orders and decrees of bodies or tribunals having any jurisdiction or authority over the same. If any discrepancy or inconsistency is discovered in the plans, drawings, specifications, or contract for this work, in relation to any such law, ordinance, regulation, order or decree, they shall forthwith report the same to the Engineer in writing. They shall at all times observe and comply with, and cause all their agents and employees to observe and comply with all such existing and future laws, ordinances, regulations, orders and decrees; and they shall protect and indemnify the Town, its officers, and agents against any claim or liability arising from or based upon violation of any such law, ordinance, regulation, order, or decree, whether by themselves or their employees.

**Q. Provisions Required by Law Deemed Inserted**

Each and every provision of law and clause required by law to be inserted in this contract shall be deemed to be inserted herein and the contract shall be read and enforced as though it were included herein, and if through mistake or otherwise any such provision is not inserted, or is not correctly inserted, then upon the application of either party the contract shall forthwith be physically amended to make such insertion or correction.

**R. Work Hours**

Unless otherwise approved by the Engineering Division and the Arlington Police Department, general work hours shall be as follows:

- Monday - Friday from 7:00 AM - 4:00 PM.

Unless otherwise approved by the Engineering Division and the Arlington Police Department, work hours on busy streets shall be as follow:

- Monday – Friday from 9:00 AM – 4:00 PM
- Busy Streets within this contract are: Gray Street, Highland Avenue, Massachusetts Avenue, Medford Street, Park Ave Extension, and Summer Street.

No work shall be done at night, on holidays, or on weekends except:

- 1) Usual protective work, such as pumping and the tending of lights and fires;
- 2) Work done in case of emergency threatening injury to persons or property;
- 3) If all of the conditions set forth in the next paragraph below are met.

No work other than that included in 1 and 2, above, shall be done at night, on holidays, or on weekends except when:

- a) In the opinion of the Engineer, the work will be of advantage to the Town and can be performed satisfactorily at night;
- b) The work shall be done by a crew organized for regular and continuous night work;
- c) The Engineer has given written permission for such night work.

#### **S. Intoxicating Liquors**

The contractor shall not sell and shall neither permit nor suffer the sale, the introduction of, or the use of intoxicating liquors upon or about the work under this contract.

#### **T. Permits and Notices**

The Contractor shall, at their own expense, take out all necessary permits from the county, municipality, or other public authorities; shall give all notices required by law, ordinances, or as required by the municipality; and shall post all bonds and pay all fees and charges incident to the due and lawful prosecution of the work covered by this contract.

#### **U. Patents**

The Contractor shall indemnify and save harmless the Town and all persons acting for or on behalf of the Town from all claims and liability of any nature or kind, including costs and expenses, arising from or occasioned by any infringement or alleged infringement of patent rights on any invention process, article, or apparatus, or any part thereof, furnished and installed by said Contractor or arising from or occasioned by the use of manufacture thereof, including their use by the Town.

#### **V. Insurance**

The Contractor shall not commence work under this contract until they has obtained all the insurance required under this paragraph and such insurance has been approved by the Town, nor shall the Contractor allow any subcontractor to commence work on their subcontract until the insurance required of the subcontractor has been so obtained and approved.

- A. Compensation Insurance: The Contractor shall procure and shall maintain during the life of this contract Workmen's Compensation Insurance as required by applicable State or territorial law for all of their employees to be engaged in work at the site of the project under this contract and, in case of any such work sublet, the Contractor shall require the subcontractor similarly to provide Workmen's Compensation Insurance for all of the latter's employees to be engaged in such work unless such employees are covered by the protection afforded by the Contractor's Workmen's Compensation Insurance. In case any class of employees engage in hazardous work on the project under this contract is not protected under the Workmen's Compensation Statue, the Contractor shall provide adequate employer's liability insurance for the protection of such of their employees as are not otherwise protected.

- B. Contractor's Public Liability and Property Damage Insurance: The Contractor shall maintain during the life of this contract Contractor's Public Liability Insurance and Contractor's Property Damage Insurance to the limits specified under SPECIAL CONDITIONS.
- C. Subcontractor's Public Liability and Property Damage Insurance: The Contractor shall either (1) require each of their subcontractors to procure and to maintain during the life of their sub-contract, Subcontractor's Public Liability and Property Damage Insurance of the type and to the limits specified under SPECIAL CONDITIONS or, (2) insure the activities of their subcontractors in their policy, specified in subparagraph (b) hereof.
- D. Scope of Insurance: The insurance required under sub-paragraphs (b) and (c) hereof shall provide adequate protection for the Contractor and their subcontractors, respectively, against damage claims which may arise from operations under this contract, whether such operations be by the insured or by anyone directly or indirectly employed by him.
- E. Proof of Carriage of Insurance: The Contractor shall furnish the Town with certificates showing the type, amount, class of operations covered, effective dates and dates of expiration of policies. Such certificates shall also contain substantially the following statement: "The insurance covered by this certificate will not be cancelled or materially altered, except after fifteen (15) days written notice has been received by the Town." If the initial insurance expires prior to completion of the work, renewal certificates shall be furnished by the date of expiration.

**W. Work Not to be Sublet or Assigned**

The Contractor shall give their personal attention constantly to the faithful prosecution of the work, shall keep the same under their personal control, and shall not assign by power of attorney or otherwise, or sublet the work or any part thereof without the previous written consent of the Town, and shall not, either legally or equitably, assign any of the moneys payable under this agreement, or their claim thereto, unless by and with the like consent of the Town and the Surety on the Bonds.

**X. Alterations**

The Engineer may by written order, and not otherwise, make alterations in the line, grade, plan, form, dimension or materials of the work, or any part thereof, either before or after the commencement of construction. If such alterations make the work less expensive to the Contractor, a proper deduction shall be made from the contract price, said deduction to be computed on the same basis as that specified under Extra Work for determining the value of approved extra work, unless there be applicable unit prices established by this contract, in which event the unit prices shall prevail.

The Contractor shall have no claims for damages or for anticipated profits on the work that thus may be dispensed with. (If such alterations make the work more expensive, a proper addition computed in the aforementioned manner shall be made to the contract price. Any such deduction or addition shall be determined by the Engineer.)

**Y. Extra Work**

The Contractor shall do any work not herein otherwise provided for, when and as ordered in writing by the Town or their agents specially authorized thereto in writing, and shall,

when requested by the Town so to do, furnish itemized statements of the cost of the work ordered and give the Town access to accounts, bills and vouchers relating thereto.

If the Contractor claims compensation for extra work not ordered as aforesaid, or for any damage sustained, they shall within one week after the beginning of any such work or of the sustaining of any such damage, make a written statement of the nature of the work performed or damage sustained, to the Town and shall on or before the fifteenth day of the month succeeding that in which any such extra work shall have been done or any such damage shall have been sustained, file with the Town an itemized statement of the details and amount of such work or damage: and unless such statements shall be made as so required, their claim for compensation shall be void, and they shall not be entitled to payment on account of any such work or damage. The Contractor shall not include in the cost of extra work any cost or rental of small tools, buildings, or any portion of the time of the Contractor, their superintendent, or their office and engineering staff.

In the alternative, the extra work order may provide that the Contractor shall receive an amount equal to the actual cost of such extra work computed on the basis of the foregoing sub-sections (a) through (g) but limited by a predetermined lump sum maximum amount.

The determination of the Town shall be final upon all questions of the amount and value of extra work, provided that such extra work has been performed under a work order approved in writing by the Town as required by the terms of this contract.

The Town shall pay and the Contractor shall receive for everything furnished and done by the Contractor to the satisfaction of the Town under an approved extra work order a predetermined lump sum amount computed on the basis of the following:

- A. the actual cost of labor employed directly on the work at prevailing rates of wages.
- B. the cost of the amounts of additional premium paid on the required insurance on account of such extra work, of Social Security or other direct assessments upon the Contractor's payroll by Federal or other properly authorized public agencies, and of other approved assessments when such assessments are not normally included in payments made by the Contractor directly to their employees, but are recognized to be part of the cost of doing work.
- C. the reasonable cost of materials incorporated in the work.
- D. the reasonable cost at fair market rental rates for equipment employed directly on the work.
- E. 15% of (a) (b) (c) and (d) for overhead and profit. (On subcontract work, this 15% will be allowed only to the subcontractor).
- F. an additional 5% of (a) (b) (c) (d) and (e) on work performed by a subcontractor of the Contractor.

## **Z. Extension of Time on Account of Extra Work**

When extra work is ordered near the completion of the contract or when extra work is ordered at any time during the progress of the work which requires in the opinion of the Engineer an unavoidable increase of time for the completion of the contract, a suitable extension of the time for completion shall be made.

**AA. Changes Not to Affect Bonds**

It is agreed and understood that any changes made in the drawings and specifications for this work (whether such changes increase or decrease the amount thereof) or any change in the manner or time of payments made by the Town to the Contractor shall in no way annul, release, or affect the liability and surety on the bonds given by the Contractor.

**BB. Completion of Work if Contract is Not Fulfilled**

If the Contractor shall be adjudged bankrupt, or if they shall make a general assignment for the benefit of their creditors, or if a receiver shall be appointed of their property, or if the work to be done under this contract shall be abandoned, or if this contract or any part thereof shall be sublet without the previous written consent of the Town, or if the contract or any claim thereunder shall be assigned by the Contractor otherwise than as herein specified, or if at any time the Engineer shall be of the opinion, and shall so certify in writing to the Town that the conditions herein specified as to the rate of progress are not fulfilled, or that the work, or any part thereof, is unnecessarily or unreasonably delayed, or that the Contractor has violated any of the provisions of this contract, the Town may terminate the contract and hold the Contractor and their sureties liable in damages as for a breach of contract by an abandonment thereof by him, or the Town may notify the Contractor to discontinue all work, or any part thereof; and thereupon the Contractor shall discontinue all work, or any part thereof, as the Town may designate and the Town may thereupon, by contract or otherwise, as it may determine, complete the work, or such part thereof, and charge the entire expense for so completing the work, or part thereof, to the Contractor: and for such completion the Town, for itself or its contractors, may take possession of and use or cause to be used in the completion of the work or part thereof any of such materials, machinery, implements and tools of every description as may be found upon the line of said work. The Town may, at its option, require the surety or sureties to complete the contract. The Town shall not be liable for any depreciation, loss or damage to said materials, machinery, implements or tools during said use, nor until such as are not incorporated in the work are removed by the Contractor after completion of the work. Unless so removed within fifteen days after mailing of notice so to do, they may be sold at public auction, after publication of notice thereof at least twice in any newspaper published in the county where the work is being performed, and the proceeds credited to the Contractor's account; or they may, at the option of the Town, be stored at the Contractor's expense subject to a lien for the storage charges.

If the Engineer shall certify as aforesaid as to the rate of progress, the Town may, instead of notifying the Contractor to discontinue all work or any part thereof, notify him from time to time to increase the work force, equipment and plant, or any of them, employed on the whole or any part of the work, stating the amount of increase required; and unless they shall, within five days after any such notice, increase their force, equipment and plant to the extent required therein, and maintain and employ the same from day to day until the condition as to the rate of progress shall, in the opinion of the Engineer, be fulfilled, the Town may employ and direct the labors of such additional force, equipment and plant as may, in the opinion of the Engineer, be necessary to insure the completion of the work or such part thereof within the time herein specified, or at the earliest possible date thereafter, and charge the expense thereof to the Contractor. Neither the notice from the Town to the Contractor to increase their force, equipment or plant, nor the employment of additional force, equipment or plant by the Town shall be held to prevent a subsequent notice from

the Town to him to discontinue work under the provisions of the preceding portion of this section.

All expenses charged under this section shall be deducted and paid by the Town out of any moneys then due or to become due the Contractor under this contract, or any part thereof; and in such accounting the Town shall not be held to obtain the lowest figures for the work of completing the contract or any part thereof, or for ensuring its proper completion, or for the additional force, equipment or plant that may be employed, but all sums actually paid therefore shall be charged to the Contractor. In case the expenses so charged exceed the sum that would have been payable under this contract if the same had been completed by the Contractor, the Contractor shall pay the amount of the excess to the Town, upon completion of the work, without further demand being made therefore.

**CC. Compensation for Work**

The Town shall pay, and the Contractor shall receive, the prices stipulated in the Proposal attached hereto as full compensation for everything furnished and done by the Contractor under this contract, including all work required but not specifically mentioned, and also for all loss or damage arising out of the nature of the work aforesaid, or from the action of the elements, or from any unforeseen obstruction or difficulty encountered in the prosecution of the work, and for all risks of every description connected with the work, and for all expenses incurred by or in consequence of the suspension or discontinuance of the work as herein specified and for well and faithfully completing the work, and the whole thereof, as herein provided.

**DD. Money may be Retained**

The Town may keep any money which would otherwise be payable at any time hereunder; may apply the same or so much as may be necessary therefore to the payment of any expenses, losses, or damages incurred by the Town and determined as herein provided; and may retain, until all claims are settled, so much of such money as the Town is of the opinion will be required to settle all claims filed with the Town, its officers, and agent relating to this contract.

**EE. Estimates and Payments**

The Engineer shall, on or about the first day of each month, except as hereinafter provided, make an estimate in writing of the total amount and value of the work done to the first of the month by the Contractor. The Town shall retain a percentage of such estimated value, as set forth under SPECIAL CONDITIONS, as part security for fulfillment of this contract by the Contractor and shall deduct from the balance all previous payments and all sums to be retained under the provisions of this contract. The Town shall pay monthly to the Contractor the balance not retained as aforesaid, except that payment may be withheld at any time if the work is not proceeding in accordance with the contract. The Town may cause estimates and payments to be made more or less frequently than once in each month.

Estimates of lump-sum items shall be based on a schedule dividing each item into is appropriate component parts together with a quantity and a unit price for each part such that the sum of the products or prices and quantities will equal the contract price for the item. This schedule shall be submitted by the Contractor for the approval of the Engineer before the first estimate becomes due.

If the Engineer determines that the progress of the work will be benefited by the delivery to the site of certain materials and equipment, when available, in advance of actual

requirement therefore and if such materials and equipment are delivered and properly stored and protected, the cost to the Contractor or subcontractor as established by invoices or other suitable vouchers may be included in the estimates.

The Engineer shall, as soon as practicable (but not more than 65 days) after the completion of the work under this contract, make a final estimate in writing of the quantity of work done under the contract and the amount earned by the Contractor. The Engineer also shall fix the date of completion of said work and incorporate the same into final estimate.

The Town shall pay to the Contractor the entire sum found to be due hereunder after deducting therefrom all previous payments, all amounts to be kept, and all amount to be retained under the provisions of this contract. Such payment shall be made not later than 15 days after, but in no event before the expiration of the time within which claims for labor performed and materials used or employed must be entered under the Lien Law, or, if such time is not specified by law, the expiration of 30 days after the completion of the final estimate.

All quantities shown on progress estimates and all prior payments shall be subject to correction in the final estimate and payment.

#### **FF. Partial Payment Not Acceptance**

It is agreed that this is an entire contract for one whole and complete work and that no partial payments on account by the Town nor the use of parts of the proposed equipment shall constitute an acceptance of any part of the work before its entire completion and final acceptance.

#### **GG. Liens**

If at any time before the expiration of the period within which claims must be entered under the Lien Law, or if not otherwise specified by law, within 30 days after the whole work herein agreed to be delivered have been performed, delivered, or completed and accepted by the Town, any person or persons claiming to have performed any labor or furnished any materials toward the performance or completion of this contract shall file with the Town suitable notice, the Town shall retain, until the discharge thereof, from the moneys under its control so much of such money as sufficient to satisfy and discharge the amount claimed to be due in such notice, together with the cost of any action or actions brought to enforce such lien created by the filing of such notice.

#### **HH. Waiver**

Neither the inspection by the Engineer, nor any act of thing done by the Town or its agents other than an express waiver by vote of the Town shall operate as a waiver of any provision of this contract; nor shall any waiver of any breach of this contract be held to be a waiver of any other subsequent breach. Any remedy provided in this contract shall be taken and construed as cumulative; that is in addition to each and every other remedy herein provided.

#### **II. Liability of the Town of Arlington**

No person, firm, or corporation, other than the signer of this contract as Contractor, now have any interest hereunder; no claim shall be made or be valid; and neither the Town nor any agent of the Town shall be liable for or be held to pay any money, except as herein provided. The acceptance by the Contractor of the payment of the final estimate shall operate as and shall be a release to the Town and every agent of the Town from all claim and liability to the Contractor for anything done or furnished for or relating to the work or

for any act or neglect of the Town or of any person relating to or affecting the work, except the claim against the Town for the remainder, if there is any, of the amounts kept or retained as herein provided.

**JJ. Guarantee**

The Contractor guarantees that the work to be done under this contract, and the workmanship performed and the materials and equipment used in the construction of the same, shall be free from defects or flaws, that each item of equipment shall be in accordance with the specifications, that the strength of all parts of all manufactured equipment shall be adequate and that the performance test requirements of the specifications shall be fulfilled. This guarantee shall be for a period of one year from and after the date of completion of the work as stated in the final estimate. The Contractor shall repair or replace as required, promptly and without charge, all work, equipment, and material, or parts thereof, which fail to meet the above guarantee during one year herein quoted.

It is hereby, however, agreed and understood that this guarantee shall not include any repairs or replacements made necessary by any cause or causes other than improper, inadequate, or defective work, workmanship, materials, or design by the Contractor or those employed directly or indirectly by him.

**KK. Money Retained for Repairs**

The Town may retain out of the monies payable to the Contractor under the contract a sum as set for under SPECIAL CONDITIONS and may expend the same, in the manner hereinafter provided, in making such repairs or replacements of said work as the Town may deem expedient.

If at any time within the said period of guarantee any part of the work constructed under the terms of this contract requires repairing or replacement, the Town may notify the Contractor in writing to make the required repairs or replacements. If the Contractor neglects to make such repairs or replacements to the satisfaction of the Town within ten (10) days from the date of receipt of such notice, the Town may employ other persons to make the same. The Town shall pay the expense of the same out of the sum retained for that purpose. Upon expiration of the said period of guarantee, provided that the work at the time is in good order, the Contractor will be entitled to receive the whole or such part of the sum last aforesaid as may remain after the expense of making said repairs or replacements, in the manner aforesaid, has been paid therefrom.

It is agreed that the Town may keep the whole or any portion of the sum retained for settlement of all claims arising out of this contract against the Town, its officers, or agents and for all expenses, losses, or damages incurred by the Town by reason of said claims.

**LL. Address of Contractor**

The Contractor's business address, their office at or near the site of the work, or the Contractor's email address, are hereby designated as places to which communications shall be delivered. The depositing of any letter, notice, or other communication in a postpaid wrapper directed to the Contractor's business address in a post office box regularly maintained by the Post Office Department or the delivery at either designated address of any letter, notice, or other communication by mail, email, or otherwise shall be deemed sufficient service thereof upon the Contractor. The first-named address may be changed at any time by an instrument in writing, executed and acknowledged by the Contractor and delivered to the Engineer. Nothing herein contained shall be deemed to preclude or render



inoperative the service of any notice, letter, email, or other communication upon the Contractor personally.

**MM. CERTIFICATE of VOTE**

I, \_\_\_\_\_, Clerk of \_\_\_\_\_,  
(Name) (Corporation)

hereby certify that, at a meeting of the Board of directors of said Corporation duly held on \_\_\_\_\_ at which a quorum was present and  
(Date)

voting throughout, the following vote was duly passed is now in full force and effect:

“VOTED” That \_\_\_\_\_  
(Name of Officer authorized to sign for corporation)

be and hereby is authorized, directed and empowered for, in the name and on behalf of this Corporation, to sign, seal with the corporate seal, execute, acknowledge and deliver all contracts, bonds and other obligations of this Corporation; by such

\_\_\_\_\_  
(Name of Officer)

to be valid and binding upon this Corporation for all purposes, and that a certificate of the Clerk of this Corporation setting forth this vote shall be delivered to the Town of Arlington; and that this vote shall remain in full force and effect unless and until the same has been altered, amended or revoked by a subsequent vote of such directors and a certificate of such later vote attested by the Clerk of this Corporation is delivered to the Town of Arlington.

I further certify that \_\_\_\_\_ is the duly  
(Name of Officer)  
elected \_\_\_\_\_ of said Corporation.  
(Title)

Signed: \_\_\_\_\_  
(Clerk - Secretary)

Place of Business: \_\_\_\_\_

Date of Contract: \_\_\_\_\_

**AFFIX COPORATE SEAL**

COUNTERSIGNATURE: \_\_\_\_\_  
(Name & Title of Officer)

In the event that the Clerk or Secretary is the same person as the Officer authorized to sign that contract or other instrument for the Corporation, this certificate must be countersigned by another officer of the Corporation.

**V. PERFORMANCE BOND**

KNOW BY ALL MEN BY THESE PRESENTS, that \_\_\_\_\_ as principal, and \_\_\_\_\_ as surety, are held and firmly bound unto the Town of Arlington, Massachusetts in the sum of \_\_\_\_\_

lawful money of the United States of America, to be paid to the Town of Arlington, Massachusetts, for which payments, well and truly to be made, we bind ourselves, our respective heirs, executors, administrators, successors and assigns, jointly and severally, firmly by these presents.

WHEREAS, the said principal has made contract with the Town of Arlington bearing \_\_\_\_\_ date of \_\_\_\_\_.

Now the condition of this obligation is such that if the principal shall well and truly keep and perform all the undertakings, covenants, agreements, terms and conditions of said contract on its part to be kept and performed during the original term of said contract and any extensions thereof that may be granted by the Owner, with or without notice to the surety, and during the life of any guaranty required under the contract and shall also well and truly keep and perform all the undertakings, covenants, agreements, terms and conditions of any and all duly authorized modifications, alterations, changes or additions to said contract that may hereafter be made, notice to the surety of such modifications, alterations, changes or additions being hereby waived, then this obligation shall become null and void; otherwise it shall remain in full force and virtue.

In the event that the contract is abandoned by the Contractor, or is terminated by the Owner, under the provisions of "C.29 – Completion of Work if Contract is not Fulfilled" in SECTION C-CONTRACT, said surety hereby further agrees that said surety shall, if requested in writing by Owner, complete said contract.

IN WITNESS WHEREOF we hereunto set our hands and seals this \_\_\_\_\_ day of \_\_\_\_\_.

\_\_\_\_\_ SEAL

\_\_\_\_\_ SEAL

PRINCIPAL

\_\_\_\_\_ SEAL

\_\_\_\_\_ SURETY

KNOW BY ALL MEN BY THESE PRESENTS, that \_\_\_\_\_  
as principals, and \_\_\_\_\_  
as surety are held and firmly bound unto the Town of Arlington, in the sum of  
\_\_\_\_\_ lawful money of the United States of America, to be paid  
to the Town of Arlington, for which payments, well and truly to be made, we bind ourselves, our respective  
heirs, executors, administrators, successors and assigns, jointly and severally, firmly by these presents.

WHEREAS, the said principal has made contract with the Town of Arlington bearing \_\_\_\_\_  
date of \_\_\_\_\_.

Now the condition of this obligation is such that if the principal shall pay for all labor performed or  
furnished and for all materials used or employed in said contract and in any and all duly authorized  
modifications, alterations, extensions of time, changes or additions to said contract that may hereafter be  
made, notice to the surety of such modifications, alterations, extensions of time, changes or additions being  
hereby waived, the foregoing to include any other purposes or items set out in, and to be subject to, the  
provisions of Massachusetts General Laws ( Ter. Ed. ), Chapter 30, Section 39A as amended and Chapter  
149, Section 29 as amended, then this obligation shall become null and void; otherwise it shall remain in  
full force and virtue.

IN WITNESS WHEREOF we hereunto set our hands and seals this \_\_\_\_\_ day  
of \_\_\_\_\_.

\_\_\_\_\_ SEAL  
\_\_\_\_\_ SEAL  
\_\_\_\_\_ PRINCIPAL  
\_\_\_\_\_ SEAL  
\_\_\_\_\_ SURETY

## VI. General Conditions

### A. Definitions

The words “directed”, “required”, “permitted”, “ordered”, “designated”, “prescribed”, or words to like import shall mean the directions, requirement, permission, order, designation, prescription, etc. of the Engineer and similarly the words “approved”, “acceptable”, or “satisfactory”, or words of like import shall mean approved by or acceptable or satisfactory to, the Engineer, subject in each case to the final determination of the Town unless otherwise expressly stated.

The word “rock” wherever used as the name of material excavated or to be excavated, shall mean the sound bedrock, properly removed by blasting, pneumatic or hydraulic hammer, wedging or barring, also such boulders exceeding 1-1/2 cubic yards in volume removed from the excavations, also any portions of existing masonry structures removed from the excavations. Sound bedrock shall not include any rock disintegrated or fractured, in the opinion of the Engineer, to such an extent as to be easily removable by a pick and shovel. The word “boulders” as used above shall include loose, detached fragments or portions of ledge and only such fragments or portions as exceed the specified 1-1/2 cubic yard limit shall be included in the classification of “rock”.

The word “earth” wherever used as the name of an excavated material or material to be excavated, shall mean all kinds of material not defined as “rock” in the above paragraph.

### B. Abbreviations

Wherever in the specifications, or on the drawings, any of the abbreviations which follow are used they shall have the following meaning:

AASHO	- American Association of State Highway Officials
ACI	- American Concrete Institute
AIEE	- American Institute of Electrical Engineers
AISC	- American Institute of Steel Construction
ASA	- American Standards Association
ASCE	- American Society of Civil Engineers
ASH&AE	- American Society of Heating and Air Conditioning Engineers
ASME	- American Society of Mechanical Engineers
ASTM	- American Society for Testing Materials
AWWA	- American Water Works Association
NBS	- National Bureau of Standards
NEC	- National Electrical Code, latest edition
NEMA	- National Electrical Manufacturers Association
Federal Specifications	- Federal Specifications issued by the Federal Supply Service of the General Service Administration, Washington, D.C.
125-lb. American Standard	- American Standard for Cast Iron Pipe Flanges and Flanged Fittings, Class 124 (ASA B16.1-1960)
O. S. & Y.	- Outside screw and yoke

**C. Handling Materials**

The Contractor shall at their own expense handle, haul and distribute all materials and equipment used and employed on the different portions of the works as required. Storage charges and demurrage charges by vendors and transportation companies, which result from delays in handling, shall be borne by the Contractor.

**D. Storage Room**

The Contractor shall provide suitable and adequate storage room for all materials during the progress of the work, and shall obtain the consent of the proper parties before entering or occupying with employees, tools, or materials, any private land outside of the property or rights of way of the Town. The Contractor shall not stockpile materials or park equipment on Town roadways unless otherwise approved by the Engineering Division.

**E. Shop Drawings, Schedules, and Descriptive Matter**

The Contractor shall furnish, as hereinafter required, all specified shop and details drawings. All drawings required shall be submitted in triplicate to the Engineer for review and in quadruplicate after review. The Engineer may alternately accept all drawings in electronic format (PDF, Word, etc.) at the Contractor's request.

The review by the Engineer of such drawings and details will be general and shall not relieve the Contractor of the responsibility for executing the entire work in accordance with the specifications and contract drawings. [Failure on the part of the Engineer to detect errors or omissions on shop drawings shall not relieve the Contractor from the responsibility for such errors or omissions.]

Should the contractor submit for review equipment that requires modifications to the structures, piping, layout, etc. detailed on the contract drawings, they shall also submit for review details of the proposed modifications. If such equipment and modifications are allowed, the Contractor, at no additional cost to the Town, shall do all work necessary to make such modifications.

The Contractor shall also furnish for the Engineer's review, all lists, schedules, and information regarding materials, fixtures and equipment as hereinafter required and specified.

All such lists, schedules, etc., shall be submitted to the Engineer for reviews within fifteen (15) days following execution of the contract. Following review by the Engineer of such materials, fixtures, and equipment, the Contractor shall promptly place orders for the equipment. Orders shall be placed within seven (7) days following the Engineer's review and proof of such order shall be furnished to the Engineer.

**F. Equivalents**

Whenever the specifications define the material or article required by using the name of a proprietary product or of a manufacturer or vendor rather than by using descriptive detail of substance and functions, the words "or equivalent" are to be understood to follow immediately the make of the maker, vendor or proprietary product. The words "or equivalent" shall be interpreted as including any material or article which, in the opinion of the Engineer, is equivalent in quality, durability, appearance, strength and design to the article named and which will perform adequately the functions imposed by the general design.

Whenever in the specifications the names of manufacturers are mentioned as indicating that their products will comply with a particular specification, or when specific trade names or plated

numbers or letters are mentioned, it is not intended to exclude products of other manufacturers whose names, trade names or symbols have not been mentioned, provided however, that such products otherwise comply, in the opinion of the Engineer, with the specifications. The Engineer's opinion in all cases mentioned in this section shall be final.

**G. Materials and Workmanship**

All materials and equipment furnished under this contract shall be of standard high-grade quality and of the best workmanship and design. No inferior or low-grade materials will be accepted, and all work must be done in a neat, first-class and workmanlike manner.

The Engineer shall have the right to test and inspect or require certificates of tests of any materials to be used in the work.

**H. Inspection by the Engineer**

All materials and equipment furnished and work done by the Contractor shall be subject to inspection by the Engineer, and defective materials shall be removed from the site of the work and defective work repaired or replaced as directed. Facilities for inspection of the work shall at all times be furnished by the Contractor.

**I. Documents at Site of Work**

The Contractor shall have available at all times, at the site of the work, copies of the contract documents, any plans and all standard specifications of the various associations which are referred to in the specifications.

**J. Lines and Grades**

The Engineer shall establish such control stations, base lines and bench marks as may be necessary for the use of the Contractor. It shall be the specific duty of the Contractor to preserve and to protect the control base lines and bench marks so established.

During construction, the Contractor shall use the control stations, base lines and bench marks established by the Engineer to develop their own lines and grades as needed to comply with those specified or shown on the drawings. The Contractor shall be held responsible for all lines and grades which they have developed.

**K. Scaffolding and Protection**

The Contractor shall provide safe scaffolding to accommodate the work as applicable. They shall build all necessary runways, temporary stairs, ladders, barricades, fences, etc.

**L. Public Safety and Property of Others**

The Contractor shall make all necessary provisions to protect the public safety, and maintain and protect existing structures of whatever kind, and shall repair all damage done to such structures. They shall give ample notification to the proper officials of any city or town, of any public utility, corporation, or other individual before entering upon their respective public ways or rights of way and shall conform to the customary regulations and requirements of said officials, corporations, or individuals.

Extra precautions must be taken to avoid splattering adjoining property, automobiles, or structures. The Contractor shall be fully responsible for all damages to same.

**M. Existing Structures, Pipes, Conduits, Etc.**

Any existing structures, pipes, conduits, wires, etc., whether presented in the Contract Documents or not, shall be protected and if damaged shall be repaired by the Contractor without additional compensation. The Contractor shall call Dig-Safe, the MWRA, the Town of Arlington Water & Sewer Division, and any other applicable agency for utility mark outs prior to commencing work as required by law.

Tie cards/Record Drawings of water, sewer, & drain mains/services within the work limits will be provided to the Contractor at their request prior to the start of work. The Contractor shall be responsible for confirming mark outs against available record drawings in the field. In the absence of a tie card, the Town will assist in locating a service.

**N. Sanitary Provisions**

The Contractor shall provide adequate sanitary facilities and maintain in a neat and sanitary condition such accommodations for the use of their employees as may be necessary to comply with the requirements of the State Department of Public Health, local health officials, and other authorities having jurisdiction. Every precaution shall be taken to prevent contamination or pollution of the ground at the site, or of any material or equipment which is to be incorporated in or used in the construction of any work under this contract.

Sanitary facilities shall be available when the first employees arrive on the site of the work, shall be properly secluded from public observation, and shall be provided and maintained during the progress of the work in suitable numbers and at such points and in such manner as may be required. Sanitary facilities shall be removed, and the surrounding areas properly cleaned and disinfected, upon completion of the work.

The Contractor shall maintain the sanitary facilities in a satisfactory and sanitary condition at all times and shall enforce their use. The Contractor shall rigorously prohibit the committing of nuisances by employees on the site of the work, on the lands of the Owner, or on adjacent property.

**O. Cutting and Patching**

The Contractor shall do all cutting, patching, drilling, grouting, etc., as necessary to complete the work, whether such work is described in the specifications or not.

**P. Management of Debris, Refuse, and Garbage and Site Cleanup**

Debris, refuse, and other garbage of any kind shall not be permitted to accumulate at any of the proposed work locations or storage areas. Debris, refuse, scrap, garbage, etc. shall be removed from the project location sites on a daily basis by the Contractor and disposed of in accordance with all Local, State, and Federal regulations. Removal and disposal of all debris, refuse, garbage, etc. shall be completed at the full cost & responsibility of the Contractor. Should the improper handling of debris, refuse, or other garbage result in pest and/or vermin infestations, the Contractor shall provide pest/vermin control services as directed by the Town. Pest/vermin control services shall be provided at no additional cost to the Town.

The work site and adjacent areas affected thereby shall at all times present a neat and orderly appearance. The Contractor must employ at all times during the progress of their work, adequate cleanup measures and safety precautions to prevent injuries to persons or damage to property.



Suitable materials, equipment, and methods shall be used for the cleanup and restoration of the project work area. The restoration of existing property or structures shall be done as promptly as practicable as work progresses and shall not be left until the end of the Contract period.

Where material or debris has washed or flowed into or been placed in existing watercourses, ditches, gutters, drains, pipes structures, or elsewhere during the course of the Contractor's operations, such material or debris shall be entirely removed by the contractor and satisfactorily disposed of during the progress of the work, and the ditches, channels, drains, pipes, structures, etc., shall, upon completion of the work, be left in a clean and neat condition.

Upon written notification by the Engineer, the Contractor shall within 24 hours clean up those areas, which in the Engineer's opinion are in violation of this section and the above referenced sections of the specifications. If in the opinion of the Engineer, the referenced areas are not satisfactorily cleaned up, all other work on the project shall stop until the cleanup is satisfactory.

The Contractor shall restore or replace, when and as directed by the Town, any public or private property damaged by their work, equipment, or employees, to a condition at least equal to that existing immediately prior to the beginning of operations. To this end, the Contractor shall repair as required all necessary highway, driveway, walk, and landscaping work damaged or disrupted during the course of the Contractor's work.

Before acceptance of work by the Owner, the Contractor shall perform a final cleanup to bring the construction site to its original or specified condition. Unless otherwise explicitly directed or permitted in writing, the Contractor shall as part of this final cleanup, tear down and remove all temporary buildings and structures built by them; shall remove all temporary works, tools, and machinery or other construction equipment furnished by them; shall remove, acceptably disinfect, and cover all organic matter and material containing organic matter in, under, and around sanitary facilities and other buildings used by them; shall remove all rubbish from any grounds which they have occupied; and shall leave the roads and all parts of the premises and adjacent property affected by their operations in a neat and satisfactory condition. Before acceptance, the Engineer shall approve the condition of the site.

#### **Q. Measurement of Quantities**

For the estimating of quantities in which the computation of areas by analytic and geometric methods would be comparatively laborious, it is stipulated and agreed that the planimeter shall be considered an instrument of precision adapted to the measurement of such areas.

For the purposes of measurement and computation of irregular volumes, the prismoidal formula shall be deemed a method of precision.

#### **R. Compliance with Occupational Safety and Health Act of 1970**

The Contractor shall in the work of this contract comply with all pertinent standards and regulations established by the Occupational Safety and Health Administration, Department of Labor by the authority of the Williams-Steiger Occupational Safety and Health Act of 1970. This project is subject to all of the Safety and Health Regulations (see 29 CFR 1518) as promulgated by the U.S. Department of Labor on April 17, 1971. Contractors are urged to make themselves familiar with the requirements of these regulations.

#### **S. Order of Precedence Governing Specifications**

The Standard Specifications for Highways and Bridges of the Commonwealth of Massachusetts, 1988 Edition plus any supplements shall be considered a part of these specifications.

In case of conflict between any sections of these specifications, plans, etc., the following order of precedence shall govern.

1. Special Provisions
2. Plans, Profiles, or Sections
3. Standard Specifications for Construction work in Arlington
4. Standard Specifications, 1988 Edition plus Supplements, for Highways and Bridges of the Commonwealth of Massachusetts.

#### **T. Affirmative Action/Anti-Discrimination**

For the purposes of this contract, “minority” refers to, but is not limited to, Asian-Americans, African-Americans, Latinos, North American Indians, and Cape Verdeans. “Town” refers to the Town of Arlington.

During the performance of this contract, the Contractor and all of their Sub-contractors (hereinafter collectively referred to as the Contractor) for themselves, their assignees, and successors in interest, agree as follows:

1. In connection with the performance of work under this contract, the Contractor shall not discriminate against any employee or applicant for employment because of race, color, religious creed, national origin, age or sex. The aforesaid provision shall include, but not be limited to, the following: employment upgrading, demotion, or transfer; recruitment advertising; recruitment layoff; termination; rates of pay or other forms of compensation; conditions or privileges of employment; and selection for apprenticeship. The Contractor shall post hereafter in conspicuous places, available for employees and applicants for employment, notices to be provided by the Town setting forth the provisions of the Fair Employment Practices Law of the Commonwealth (M.G.L. Chapter 151B).
2. In connection with the performance of work under this contract, the Contractor shall undertake in good faith affirmative action measures designed to eliminate any discriminatory barriers in the terms and conditions of employment on the grounds of race, color, religious creed, national origin, age or sex, and to eliminate and remedy any effects of such discrimination in the past. Such affirmative action shall entail positive and aggressive measures to ensure equal opportunity in the areas of hiring, upgrading, demotion or transfer, recruitment, layoff or termination, rate of compensation, and in-service or apprenticeship training programs. This affirmative action shall include all action required to guarantee equal employment opportunity for all persons, regardless of race, color, religious creed, national origin, age or sex. A purpose of this provision is to ensure to the fullest extent possible an adequate supply of skilled tradesman for this and future Town public construction projects.
3. As part of their obligation of remedial action under the foregoing section, the Contractor shall maintain on this project a not less than five percent ration of minority employee man hours to total man hours in each job category including but not limited to bricklayers, carpenters, cement masons, electricians, ironworks, operation engineers and those “classes of work” enumerated in Section 44C of Chapter 149 of the Massachusetts General Laws.
4. In the hiring of minority journeyman, apprentices, trainees and advances trainees, the Contractor shall rely on referrals from a multi-employer affirmative action program approved by the Town, traditional referral methods utilized by the construction industry,

and referrals from agencies, not more than three in number at any one time, designated by the Liaison Committee or the Town.

5. At the discretion of the Town there may be established for the life of this contract a body to be known as the Liaison Committee. The Liaison Committee shall be composed of one representative each from the agency or agencies administering this project, hereinafter called the administering agency, the Town and such other representative as may be designated by the Town in conjunction with the administering agency.
6. The Contractor (or their Agent, if any, designated by him as the on-site equal employment opportunity officer) shall recognize the Liaison Committee as an affirmative action body, and shall establish a continuing working relationship with the Liaison Committee, consulting with the Liaison Committee on all matters related to minority recruitment, referral, employment and training.
7. The Contractor shall prepare projected manning tables on a quarterly basis. These shall be broken down into projections, by week, or workers required in each trade. Copies shall be furnished one week in advance of the commencement of the period covered, and also when updated, to the Town or Liaison Committee.
8. Records of employment referral orders, prepared by the Contractor, shall be made available to the Town and to the Liaison Committee on request.
9. The Contractor shall prepare weekly reports in a form approved by Town of hours worked in each trade by each employee, identified as minority or non-minority. Copies of these shall be provided at the end of each such week to the Town and to the Liaison Committee.

If the Contractor shall use any sub-contractor on any work performed under this contract, they shall take affirmative action to negotiate with qualified minority sub-contractors. This affirmative action shall cover both pre-bid and post-bid periods. It shall include notification to the Office of Minority Business Assistance (within the Executive Office of Communities and Development) or its designee, while bids are in preparation, of all products, work or services for which the Contractor intends to negotiate bids.

In the employment of journeymen, apprentices, trainees and advanced trainees, the Contractor shall give preference, first, to citizens of the Commonwealth who have served in the armed forces of the United States in time of war and have been honorably discharged there from or released from active duty therein, and who are qualified to perform the work to which the employment relates, and, secondly, to citizens of the Commonwealth generally, and, if such cannot be obtained in sufficient numbers, then to citizens of the United States.

A designee of the Town and a designee of the Liaison Committee shall each have right of access to the construction site.

#### **1. Compliance with Requirements**

The Contractor shall comply with the provisions of Executive Order O, 74, as amended by Executive Order NO. 116 dated May 1, 1975, and of Chapter 151B as amended, of the Massachusetts General Laws, both of which are herein incorporated by preference and made a part of this contract.

#### **2. Non-Discrimination**

The Contractor, in the performance of all work after award, and prior to completion of the contract work, will not discriminate on grounds of race, color, religious creed,

national origin, age or sex in employment practices, in the selection or retention of sub-contractors, or in the procurement of materials and rentals of equipment.

### **3. Solicitations for Sub-Contracts, and for the Procurement of Materials and Equipment**

In all solicitations either by competitive bidding or negotiation made by the Contractor either for work to be performed under a sub-contractor for the procurement of materials or equipment, each potential sub-contractor or supplier shall be notified in writing by the Contractor of the Contractor's obligations under this contract relative to non-discrimination and affirmative action.

### **4. Bidders Certification Requirement**

1. The bidder's certification form currently in use will be deleted from all future bid documents.
2. The following certification statement will be inserted in the bid document just above the bidders signature, as a substitute for the present bidder certification form:

“The bidder hereby certifies they shall comply with the minority manpower ratios and specific action steps contained in the appendix EEO attached hereto, including compliance with the minority contractor compliance specified in Section V of said appendix. The contractor receiving the award of the contract shall be required to obtain from each of its sub-contractors and submit to the contracting or administering agency prior to the performance of any work under said contract a certification by said sub-contractor, regardless of tier, that it will comply with the minority manpower ratio and specific affirmative action step contained in the appendix EEO.”

### **5. Contractor's Certification**

The Contractor's certification form must be signed by all successful low bidder(s) prior to award by the contracting agency. (See attachment).

### **6. Compliance-Information, Reports and Sanctions**

1. The Contractor will provide all information and reports required by the administering agency or the Town on instructions issued by either of them and will permit access to its facilities and any books, records, accounts and other sources of information which may be determined by Town to affect the employment of personnel. This provision shall apply only to information pertinent to the Town's supplementary affirmative action contract requirements. Where information required is in the exclusive possession of another who fails or refuses to furnish this information, the Contractor shall so certify to the administering agency of the Town as appropriate and shall set forth what efforts they have made to obtain the information.
2. Whenever the administering agency, the Town, or the Liaison Committee believes the General Contractor or any Sub-contractor may not be operating in compliance with the terms of this Section, the Town directly, or through its designated agent, shall conduct an appropriate investigation, and may confer with the parties, to determine if such Contractor is operating in compliance with this Section. If the Town or its agent finds the General Contractor or any Sub-contractor not in compliance, it shall make a preliminary report on non-compliance, and notify such Contractor in writing of such steps as will in the judgment of the Town or its agent bring such Contractor into compliance. In the event that such Contractor fails or refuses to fully perform

such steps, the Town shall make a final report of non-compliance, and recommend to the administering agency the imposition of one or more of the sanctions listed below. If, however, the Town believes the General Contractor or any Sub-contractor has taken or is taking every possible measure to achieve compliance, it shall not make a final report of non-compliance. Within fourteen (14) days of the receipt of the recommendations of the Town, the administering agency shall move to impose one or more of the following sanctions, as it may deem appropriate to attain full and effective enforcement:

- a. The recovery by the administering agency from the General Contractor of 1/100 of 1% of the contract award price or \$1000 whichever sum is greater, in the nature of liquidated damages or, if a Sub-contractor is in non-compliance, the recovery by the administering agency from the General Contractor, to be assessed by the General Contractor as a back charge against the Sub-contractor, of 1/10 of 1% of the sub-contract price, or \$400 whichever sum is greater, in the nature of liquidated damages, for each week that such party fails or refuses to comply.
  - b. The suspension of any payment or part thereof due under the contract until such time as the General Contractor or any Sub-contractor is able to demonstrate their compliance with the terms of the contract.
  - c. The termination, or cancellation, of the contract, in whole or in part, unless the General Contractor or any Sub-contractor is able to demonstrate within a specified time their compliance with the terms of the contract.
  - d. The denial to the General Contractor or any Sub-contractor of the right to participate in any future contracts awarded by the administering agency for a period of up to three years.
3. If at any time after the imposition of one or more of the above sanctions a Contractor is able to demonstrate that they are in compliance with this Section, they may request the administering agency, in consultation with the Town, to suspend the sanctions conditionally, pending a final determination by the Town as to whether the Contractor is in compliance. Upon final determination of the Town, the administering agency, based on the recommendation of the Town, shall either lift the sanctions or re-impose them.
  4. Sanctions enumerated under Sections 2 shall not be imposed by the administering agency except after an adjudicatory proceeding, as that term is used M.G.L. c. 30A has been conducted. No investigation by the Town or its agent shall be initiated without prior notice to the Contractor.

## **7. Severability**

The provisions of this section are severable, and if any of these provisions shall be held unconstitutional by any court of competent jurisdiction, the decision of such court shall not affect or impair any of the remaining provisions.

## **VII. SPECIAL CONDITIONS**

### **A. SCOPE OF SPECIAL CONDITIONS**

Whenever conditions as set forth in SECTION SC – SPECIAL CONDITIONS conflict with SECTION C – CONTRACT OR SECTION S – DETAIL SPECIFICATIONS, the SPECIAL CONDITIONS shall apply.

### **B. MINIMUM LIMITS FOR INSURANCE**

The minimum limits required under “C.23 – Insurance” in SECTION – CONTRACT shall be as follows:

- a. Compensation Insurance – as required by the General Laws of the Commonwealth of Massachusetts.
- b. Contractor’s Public Liability Insurance – in an amount not less than \$500,000 for injuries including wrongful death to any person and subject to the same limit for each person in an amount not less than \$1,000,000 on account of one accident.
- c. Property Damage Insurance – in an amount not less than \$500,000 for a single accident or less than \$1,000,000 in the aggregate.

### **C. RETAINAGE**

The Town shall retain five (5) percent of any periodic estimate and one (1) percent of the value of the completed contract for repairs for a period of one (1) year from substantial completion.

### **D. PAYMENT OF SUMS DUE CONTRACTOR**

Replace SECTION – C-38 of the Contract with the following:

C-38 – Payment of Sums Due Contractor – All payments and retainage shall be in accordance with SECTION 39G of Chapter 30 of the Massachusetts General Laws.

### **E. DISPOSAL OF EXCAVATED MATERIAL**

It shall be the Contractor’s responsibility to dispose of unsuitable material and any excavated material including pipe, valves, and fittings which are not required for use within the locus of the work, as determined by the Engineer and/or the Director of Public Works, outside the locus of the work, in a Contractor furnished disposal area, and shall become the property of the Contractor.

### **F. EXCERPTS FROM CERTAIN LAWS**

Particular attention is called to certain excerpts of the General Laws of the Commonwealth of Massachusetts.

#### Preference in Employment of Labor:

In the employment of mechanics, teamsters, chauffeurs and laborers in the construction of this public work, the Contractor shall give preference first, to citizens of the Commonwealth who have been residents of the Commonwealth for at least six months at the commencement of their employment who are veterans as defined in General Law (Ter. Ed.), Chapter 4, Section 7, Clause 43, and who are qualified to perform the work to which the employment relates; and secondly, to citizens of the Commonwealth who have been residents of the Commonwealth for at least six months at the commencement of their employment, and if they cannot be obtained in sufficient numbers, then to citizens of the United States. Veterans and citizens of the Town shall be given preference in employment of the work.

Labor, Lodging, Board, Maximum Hours of Employment and Weekly Payment:

Every employee in public work shall lodge, board and trade where and with whom they elects; and no person or their agents or employees under contract with the Commonwealth, a county, city or town, or with a department, board, commission or officer acting therefore, for the doing of public work shall directly or indirectly require as a condition of employment therein, that the employee shall lodge, board or trade at a particular place or with a particular person per General Law (Ter. Ed.), Chapter 149, Section 25.

No laborer, workman, mechanic, foreman or inspector working within the Commonwealth, in the employ of the Contractor, sub-contractor or other person doing or contracting to do the whole or a part of the work contemplated by this contract, shall be required to work more than eight (8) hours in any one day or more than forty-eight (48) hours in any one week, or more than six (6) days in any one week, except in cases of emergency, or in case any Town subject to Section 31 of the General Laws is a party to such a contract, more than eight (8) hours in any one day, except as aforesaid. General Laws (Ter. Ed.), Chapter 149, Section 34, as amended.

Attention of the bidders is called to Chapter 149, Section 148 of the General Laws (Ter. Ed.), and amendments thereof requiring the weekly payment of employees.

**G. REGULATIONS OF THE COMMONWEALTH OF MASSACHUSETTS**

This contract is subject to the requirements of the Massachusetts General Laws (MGL) of which the following are of major significance:

MGL Chapter 30, Section(s) 39F, G, N, O and P.

MGL Chapter 30, Section 40

MGL Chapter 30, Section 39R

MGL Chapter 30, Section(s) 39K and L

MGL Chapter 44, Section 31C (chapter 693 of 1964)

MGL Chapter 82, Section 40 (chapter 353 of 1983)

MGL Chapter 149, Section 34

**H. ADJACENT CONTRACTS**

The Contractor's attention is directed to the fact that work by utility companies, municipal departments and other contractors may be carried on concurrently within and adjacent to the limits of the contract. The said companies, municipal departments and other contractors may require access over the site and the Contractor shall do their work in cooperation with them. The attention of the Contractor is also directed to the provisions of General Laws, Chapter 82, Section 40 which requires Contractor to notify public utility companies, in writing, at least seventy-two (72) hours (excluding Saturdays, Sundays, and legal holidays) before excavating that portion of the project that is within a public way. This notification is the sole responsibility of the Contractor.

**I. TRAFFIC ORDERS**

The Town of Arlington will pay all charges for the services of uniformed police officers. The Contractor will be responsible for the coordination of ordering and/or cancelling police details as needed. Cancellations must be made a minimum of 1-hour in advance of the scheduled detail. The Contractor will be liable for charges incurred for cancellations that occur less than 1-hour in advance of the scheduled detail.

## **J. TIME FOR COMPLETION AND LIQUIDATED DAMAGES**

All the work proposed under this contract, shall be completed in accordance with the below-phased milestones:

- **DECEMBER 31, 2022**

In case the Contractor fails to satisfactorily complete the entire work contemplated and provided for under their contract on or before the date of completion as determined herein, the Town shall deduct from the payments due the Contractor the sum of one thousand dollars (\$1,000.00) for each calendar day (Saturdays, Sundays and legal holidays excluded) of delay, which sum is agreed upon not as a penalty, but as fixed and liquidated damages for each day of such delay, to be paid in full and subject to no deduction. If the payments due to the Contractor are less than the amount of said liquidated damages, said damages shall be deducted from any other monies due or to become due the Contractor, and in case the damages exceed the amount of all monies due or to become due the Contractor, the Contractor, or their Surety, shall pay the balance to the Town. No work shall be done between November 15<sup>st</sup> and April 15<sup>th</sup> without the express written consent of the Director of Public Works.

## **K. RESTORATION OF SURFACE**

It shall be the responsibility of the Contractor to restore all surfaces in accordance with Section S56. (Bituminous Concrete Paving and Concrete Walks). No more than one-hundred fifty (150) feet of trench shall be left without temporary patch during the work week, and no trenches shall be left without temporary patch during weekends or municipally recognized holidays.

## **L. PROTECTION OF TREES**

The attention of the Contractor is directed to the fact that there may be existing Public Shade Trees located in the project work area. Public Shade Trees are protected under Massachusetts General Law Chapter 87. No Public Shade Tree shall be cut, pruned, trimmed, marked, posted, removed, or altered, including roots, in any such manner without the written permission of the Town of Arlington Tree Warden. Extreme caution shall be taken by the Contractor to assure that these trees are not harmed during construction operations.

The Contractor shall notify the Engineer and the Town of Arlington Tree Warden in advance of initiating operations in close proximity to any tree. When tree roots are encountered during trench excavation, the Contractor shall notify the Tree Warden, and uncover the remainder of the roots within the confines of the excavation with hand tools. The exposed roots shall be thoroughly soaked with water and protected with burlap, paper or polyethylene from the direct rays of the sun. Tree roots shall not be cut by the Contractor except with the expressed permission of the Tree Warden.

The Contractor shall also inform the Tree Warden if the limbs of any trees hanging over the work area may impede progress or be at risk of damage from construction equipment. The Contractor shall coordinate proper tree protection or pruning methods with the Tree Warden at no additional expense to the Town.

The Contractor shall be liable for the replacement of any trees adversely impacted by their work activities, as determined by the Tree Warden.

## **M. INTERPRETATION OF CONTRACT**

This contract shall be interpreted in accordance with the laws of the Commonwealth of Massachusetts. All actions, claims and disputes hereunder shall be presented to the applicable agency of the Commonwealth of Massachusetts.



**N. CONTROL OF WATER SYSTEM**

The Arlington Department of Public Works Water and Sewer Division shall maintain control of the use or operation of any and all gate valves, hydrants, etc., and shall be notified by the Contractor two (2) business days in advance of any use or operation of the above except in a case of an emergency; however, the Department of Public Works Water and Sewer Division shall be informed immediately upon said emergency use or operation.

**O. COMMUNITY NOTICES, COORDINATION, AND NO PARKING SIGNS**

Contractor shall be responsible for posting Notices to residents affected by proposed construction throughout the course of the project. At minimum, Notices will be required for the following: project introduction (type of work, anticipated start of work and duration, etc.); emergency contact information; road closures; utility shutdowns; emergency conditions; and progress updates, as applicable. Additional Notices may be required by the Engineering Division at no additional cost to the Town. Unless otherwise noted or agreed upon in writing, Notices shall be prepared by the Contractor, submitted to the Engineering Division for review and approval, and distributed by the Contractor upon approval by the Engineering Division. In instances where standard notices have already been developed by the Engineering Division, these notices may be provided by the Engineering Division and be distributed by the Contractor.

The Contractor shall give at least two (2) business days notice to the AFFECTED RESIDENTS of the need to withdraw a water main from service in order to facilitate the disconnection or connection of the new mains with existing mains.

The Contractor shall post "No Parking" signs in areas of proposed work a minimum of two (2) business days prior to construction as directed by the Engineering Division. The Contractor may obtain standard no parking signs from the Engineering Division upon which they shall clearly note the date and time of parking restrictions. Should the Contractor decide to provide their own signs, they shall first be provided for review and approval by the Engineering Division. Contractor is responsible for maintaining and replacing signs in place and/or modifying date and time restrictions as necessary.

The contractor shall coordinate work plans with all applicable Town Departments (e.g. Water/Sewer Division, Police Department, Fire Department, etc.) and other organizations (e.g. MBTA for road closures with bus routes, MWRA, DigSafe, utility companies, etc.) affected by construction and as directed by the Engineering Division.

The Contractor shall provide emergency contact information for residents, Town departments, and other applicable organizations prior to the start of construction.

**P. AWARD OF CONTRACT**

The Town reserves the right to award the contract in part or in whole.

**Q. WORKSITE DUST CONTROL**

The worksite shall be kept free of dust and other sediments to the greatest extent practical. In an effort to accomplish this, on a weekly basis at minimum, the entire site shall be swept by a vehicle-mounted, mechanical sweeper. Further, on days in which work is completed within any designated resource area, the work area within this buffer zone shall be swept on a daily basis. All sweepings and material collected from these required cleanings shall be properly disposed of at the full cost and responsibility of the Contractor.

Between sweepings, the Contractor shall use calcium chloride as needed to control dust on-site. Calcium chloride shall be applied when ordered by the Engineer and only in areas which will not

be adversely affected by the application. Calcium chloride shall be uniformly applied at the rate of 1 ½ pounds per square yard or at any other rate as directed by the Engineer. Application shall be by means of a mechanical spreader or other approved methods. The number and frequency of applications shall be determined by the Engineer. The application of calcium chloride shall not be permitted in designated environmental resource areas or buffer zones without the prior consent of the Town of Arlington Conservation Commission.

Calcium chloride used on-site shall conform to the requirements of AASHTO-M144, Type I or Type II and Specification for Calcium Chloride, ASTM D98. The calcium chloride shall be packaged in moisture proof bags or in airtight drums with the manufacturer, name of product, net weight, and percentage of calcium chloride guaranteed by the manufacturer legibly marked on each container. Calcium chloride failing to meet the requirements of the aforementioned specifications or that which has become caked or sticky in shipment may be rejected by the Engineer.

## **R. CONSTRUCTION SEQUENCE**

Upon execution of the contract, the construction sequence shall be summated by the Contractor and approved by the Engineer.

## **S. MEASUREMENTS AND PAYMENT**

The purpose of this Section is to define the method of measurement and payment for each of the unit prices or lump sums listed in the Bid Proposal. If no bid item appears in the Bid Proposal for any of the following described items, no work of that description is anticipated on the project.

1. The Contractor shall thoroughly review the work required for each payment item.
2. The Contractor shall have included in his various bid items, an amount to cover costs for additional work which may be necessary, to construct the water mains in close proximity of underground facilities, services, poles and other facilities which may exist.
3. The discovery of an underground facility during the construction shall not constitute automatic initiation of a change order. The additional work to cross or pass this underground facility must be substantial for consideration for additional payment.
  - a. The word “substantial” as used above shall mean that an additional amount of work is required, beyond the work that is normally required in the crossing or paralleling of an underground facility.

There will be no separate payment for compliance with the Commonwealth of Massachusetts COVID-19 Guidelines and Procedures for All Construction Site and Workers at All Public Work document. The costs associated with compliance shall be included in the various unit price or lump sum bid prices in the contract.

### **1.01 TRENCH PAYMENT LIMITS**

- A. The measurements for trench payment limits shall be used for the volume of computing excavation below grade and trench related items.
  - 1. Trench limits in earth and rock shall be measured within vertical lines. The measured lines shall not exceed a width equal to three (3) feet.
  - 2. Grade shall be measured vertically from the surface of the existing ground to a maximum point of twelve (12) inches below the bottom of the pipe, for trenches in earth. In trenches where rock is encountered, grade shall be one (1) foot below the bottom of the pipe.
  - 3. In paved roadways the trench width at the roadway surface, to a depth of twelve (12) inches below the surface shall not exceed a width of five (5) feet.
  - 4. If the Owner orders additional width beyond the above-specified limits, or below grade excavation, the width or depth ordered will be considered for payment, as will the refill material.

### **1.02 EARTH EXCAVATION FOR PIPELINE TRENCHES**

- A. Earth excavation for pipeline trenches from the existing ground surface to pipe sub-grade shall not be paid for separately, and all costs for this excavation shall be included in the unit prices paid for the various pipe laying items.

### **1.03 PIPE BEDDING**

- A. Material used for Pipe Bedding shall be reasonably dry material as delivered to the site and which is subsequently placed. There will be no separate measurement or payment for furnishing and placing, crushed stone bedding, bank run sand and gravel. The cost of such materials and work shall be included in the unit price for the various pipe laying items.

### **1.04 EXCESS EXCAVATED MATERIAL**

- A. All costs for transporting, disposing, or reusing of excess material obtained within this Contract shall be included in the various pipe laying items.

### **1.05 EXISTING WATER MAIN SHUTDOWN COORDINATION**

- A. The Contractor shall contact the Town of Arlington Water & Sewer Division to coordinate any required water main shutdowns. The Contractor shall not operate any Town distribution system valves without the permission of the Water & Sewer Division. No separate payment shall be made for labor, materials, tools, and equipment necessary for or incidental to the coordination of shutdowns of existing water mains in the event of an emergency. The Contractor shall assist the Owner in a shutdown as necessary to properly remove a failed wet tap, existing corporation leak, etc. The cost for this item shall be included in the unit price for the various pipe laying items.

### **1.06 RESTORATION OF DAMAGED AREAS**

- A. The Contractor shall be responsible for site restoration. The limit of work shall be defined as 5-feet on either side of the existing service line on private property. The site shall be restored to like or better than existing conditions as displayed in Appendix A of the site

photos. The Contractor will be responsible for loam and seed, driveway/pavement trench restoration, retaining wall restoration, and vegetation replanting only. Contractor is responsible for restoring all disturbed areas beyond the limit of work.

- B. All public or private monuments, iron pipes or other types of property line and geodetic markers damaged or disturbed by operations under this Contract shall be reset by a licensed land surveyor - all at no additional cost to the Owner. All other work, under this Section, shall not be paid separately, but shall be considered incidental to the work and included in the unit price and lump sum items.

### **1.07 TRAFFIC REGULATION**

- A. The Town of Arlington will pay all charges for the services of uniformed police officers. The Contractor will be responsible for the coordination of ordering and/or cancelling police details as needed. Cancellations must be made a minimum of 1-hour in advance of the scheduled detail. The Contractor will be liable for charges incurred for cancellations that occur less than 1-hour in advance of the scheduled detail.
- B. All costs for furnishing lighted barricades and traffic protection devices and for labor, equipment and services involved in the erecting, maintaining, moving, adjusting, relocating and storing of signs, flashers, lights, barricades, traffic cones, traffic delineators and other devices furnished by the Contractor, as well as the cost of all labor and equipment involved in the maintenance of traffic lanes and detours ordered or included in the approved scheme for maintenance of traffic shall be included in the unit price for various pipe laying items. No additional payment will be made for maintaining access to the work area for emergency vehicles, school buses, and residents. No additional payment will be made for temporary pedestrian walkways required by the Engineer.

### **1.09 MEASUREMENT OF QUANTITIES**

- A. The quantities of the various items of work performed shall be determined, for purposes of progress and final payment, by the Contractor and reviewed by the Engineer.
- B. The method of measurements to be used in the determination of quantities of the work of this Contract shall be as specified in this Section.
  - 1. Area Measurements
    - a. Unless otherwise specified, measurement for area computations shall be made along the surface and taken to the nearest half (1/2) foot.
  - 2. Linear Measurements
    - a. All items such as pipe, service tubing, and curbing, etc., shall be made along the alignment of the item, at the surface, and taken to the nearest foot.
  - 3. Volume Measurements - In figuring volumes, the following shall apply:
    - a. Excavation Below Grade: Measurements shall be taken to the grade actually excavated as ordered, and within the trench payment limits specified in this Section.
    - b. Test Pits: Measurements shall be taken to the lines and grade actually excavated.
    - c. Rock and Boulder: Only boulders greater than one (1) cubic yard in volume and rock, shall be measured for payment. Measurements shall be taken to the lines and grades as specified, in the trench payment limits in this Section.
  - 4. Lump Sum: The term "lump sum" when used as a unit of payment, shall mean complete payment for the work described in the Contract Documents.

5. Per Each: The term “per each” when used as a unit of payment, shall mean complete payment for each unit furnished and installed, completed and accepted, as described in the Contract Documents.
6. Ton: When used as a pavement payment item, shall be arrived at by the following method:
  - a. Payment shall be calculated by measurements of the surface area, within the payment limits, by square yards, times the depth of the pavement, times a factor of .056, for a conversion to ton basis.
  - b. A five (5) percent service factor shall be allowed if a comparison between measurements and delivery slips indicate that additional material was placed. If a comparison between delivery slips and measurements indicate less material was placed, the slip quantity shall be used for payment. The Contractor shall submit to the Engineer, one (1) copy of the certified weight slips for all asphaltic concrete used in the Work.

#### **1.10 ITEM LIST**

- 1. Test Pit**
- 2. Rock/Ledge Excavation**
- 3. ¾” Copper Tubing**
- 4. ¾” Corporation Stop**
- 5. ¾” Curb Stop and Curb Box**
- 6. 1” Copper Tubing**
- 7. 1” Corporation Stop**
- 8. 1” Curb Stop and Curb Box**
- 9. Curb Box Replacement Only**
- 10. Abandon Existing Service**
- 11. Connection to Meter**
- 12. Sewer Repair**
- 13. Drain Repair**
- 14. 4” HMA Trench Paving**
- 15. In Kind Sidewalk Replacement**
- 16. Loam and Seed**

#### **Item No. 1: Test Pit**

Payment shall be made at the unit price bid per cubic yard (CY) under Bid Item No. 1 in the Bid Form. Payment shall be full compensation for all labor, tools, equipment and all incidental work necessary to complete the work under this item, including but not limited to pavement cutting

and removal, excavation, hand digging, sheeting, shoring, dewatering, backfill material, backfilling and compaction of the backfill all as required by the Contract Documents.

Test pits shall be performed to determine the existing water service material as directed by the Owner. No payment shall be made under this item if a service installation is completed as a result of the excavation, as the test pit excavation shall be considered incidental to the installation and shall be paid for under applicable pipe laying items (i.e. ¾" copper tubing, ¾" corporation stop, etc.). If the existing water service tubing is found to be copper and is not replaced, the work shall be paid for under this unit item.

**Item No. 2: Rock/Ledge Removal**

Under Bid Item No. 2 the Contractor will be paid the contract unit price per cubic yard (CY) for rock excavation and/or for rock or ledge removed greater than one (1) cubic yard in volume from the trench(es) and subsequently disposed of at an off-site location, which unit price shall be full compensation for all labor, tools, equipment and all incidental work necessary to complete the work under these item as directed by the Engineer and as specified herein.

**Item No. 3 and Item No. 6: ¾ inch and 1 inch Copper Service Tubing**

Under Bid Item No. 3, and Bid Item No.6 the Contractor will be paid the contract unit price per linear foot (LF) for all labor, materials, tools, equipment, and all incidentals necessary to complete the work under this item as directed by the Engineer and as specified herein. The work includes but is not limited to furnishing, sawcutting, excavating, trenching, laying of the pipe, pipe bedding, sand borrow, gravel borrow for roadway base, and the subsequent backfilling of ¾-inch and 1-inch service trenches, complete in place, inclusive of the excavation, removal, and disposal of all unsuitable material(s) and existing service tubing being replaced. Contractor will be responsible for shoring, trenchless methods, open cut methods, hand digging, bracing utility poles as required, and other means necessary for installation of the service tubing. The Contractor shall ream and connect to the existing corporation. The Contractor will also be responsible for notifications and coordination with homeowners and the Town of Arlington Department of Public Works. Contractor will be responsible for providing as-built ties of the new services. No additional payment shall be made for failed trenchless service tubing installations requiring open cut excavation.

**Item No. 4, Item No. 5, Item No. 7, and Item No. 8: ¾ inch and 1 inch Corporation Stops, Curb Stops and Boxes**

Under Bid Item No.4, No. 5, No.7, and No. 8, the Contractor will be paid the contract unit price for furnishing and installing each (EA) corporation (inclusive of saddle and adaptors as applicable), and each curb stop and service box complete in place. Saddles shall be used for all corporations and/or repairs on asbestos cement and PVC water mains only.

Under Bid Item No.4, No. 5, No.7, and No. 8, the unit prices shall include full compensation for all labor, materials, tools and equipment and all incidentals necessary to complete the work under these items as directed by the Engineer and as specified herein, inclusive of excavation and the disposal of all undesirable material(s), backfilling, connection to water main with repair saddle, bracing utility poles as required, as-built ties,

and notifications. The work also includes removal and disposal of existing curb stops and service boxes if deemed unusable.

**Item No. 9: Curb Box Replacement**

Under Bid Item No. 9 the Contractor will be paid the contract unit price for furnishing and installing each (EA) service box complete in place inclusive of all labor, tools, equipment and all incidental work necessary to complete the work under this item. The work also includes removal and disposal of existing service box. Work will only be paid under Bid Item No. 9 where the existing curb stop is remaining in place, the existing curb box is damaged, or replacement is requested at the discretion of the Owner or Engineer. Decision to replace the curb box only will be made at the discretion of the Owner and/or Engineer.

**Item No. 10: Abandon Existing Corporation**

Under Bid Item No. 10 the Contractor will be paid the contract unit price for abandoning an existing corporation complete in place (EA) inclusive of all labor, tools, equipment and all incidental work necessary to complete the work under this item. The work also includes cut and cap of existing corporation, furnishing and installation of a wrap around corporation sleeve, and coordination of water main shutdowns if necessary.

Work will only be paid under Bid Item No. 10 where the existing corporation stop is damaged, leaking, or replacement is requested at the discretion of the Owner or Engineer. Decision to abandon the corporation stop only will be made at the discretion of the Owner and/or Engineer.

**Item No. 11: Connection to Water Meter**

Payment shall be made at the unit price bid per each (EA) under Bid Item No. 11 in the Bid Form. The unit price shall include full compensation for all labor, materials, fittings, shut off valves, tools and equipment, coring or jackhammering of basement foundation/slabs, mortar and hydraulic cement repair of walls or slabs, and all incidentals necessary to connect a new service line to an existing water meter as directed by the Engineer and as specified herein.

**Item No. 12, and Item No. 13: Sewer Repair and Drain Repair**

Payment shall be made at the unit price bid per each (EA) under Bid Item No. 12 and No. 13 in the Bid Form. Payment shall be full compensation for repair or replacement of existing sewer and drainage damaged within the trench limits during construction as a result of the location not being marked or the location being mismarked by more than 5 feet, and shall include all labor, tools, equipment and all incidental work necessary to complete the work under this item including but not limited to SDR 35 PVC Pipe, Fernco couplings, excavation, dewatering, shoring, bedding, backfilling and compacting, restoration of private and public property to original condition all as required by the Contract Documents.

**Item No. 14: 4" Hot Mix Asphalt Paving**

Payment shall be made at the price bid per ton (Ton) as measurements of the surface area, within the payment limits, by square yards, times the depth of the pavement, times a factor of .056, for a conversion to ton basis under Bid Item No. 14 in the Bid Form.

Payment shall be full compensation for all labor, tools, equipment and all incidental work necessary to complete roadway trench paving, including but not limited to preparatory work and furnishing, placing and compacting the asphaltic concrete pavement as required by the Contract Documents. The price shall include the cost of the bituminous material placement and maintenance of the construction to include additional materials and labor required due to settlement and/or maintenance over a winter season, tack coat, cutting or keying of the pavement, removal and resetting all manhole frames, gate boxes, curbs, catch basins, line stripping, etc.; and the repair of traffic loop detectors and reflectorized pavement markings. This bid item is for the paving of trenches within roadway surfaces only. The restoration of asphalt sidewalks shall be paid for under item No. 15.

**Item No. 15: In Kind Sidewalk Replacement**

Payment shall be made at the unit price bid per square yard (SY) as measurements of the surface area, within under Bid Item No. 15 in the Bid Form. Replacement of the sidewalk shall match the existing material that was present prior to excavation. For asphalt sidewalk, restoration shall include a minimum of 3 inches of bituminous concrete. For concrete sidewalks, restoration shall include a minimum of 4 inches of 4000 PSI concrete. The price shall include the resetting of existing granite curb and cobblestones, and restoration of asphalt berm if present. Payment shall include full compensation for all labor, materials, tools and equipment, and all incidentals necessary to complete the work under this item as directed by the Engineer and as specified herein.

**Item No. 16: Loam and Seed**

Payment shall be made at the unit price per square yard (SY) measured under Bid Item No. 16 in the Bid Form. Payment shall be full compensation for furnishing and installing loam and seed as required by the Contract Documents. Payment made under this section shall be considered as full compensation for furnishing all labor, materials, equipment and services to reproduce grassed lawn in areas disturbed by construction operations no greater than 10 feet in either direction from the centerline of the trench, or within 3 feet of curbing and sidewalks. The payment shall be considered full compensation to produce new grassed lawn areas. All areas disturbed as a result of the Contractors operations which are outside the standard width shall be at the Contractor's expense. The topsoil shall be furnished from off-site sources, screened so that no stones greater than ½" diameter are present, treated, spread, seeded and fertilized and shall be paid under Bid Item No. 16.





Engineering Division

**TOWN OF ARLINGTON**  
**DEPARTMENT OF PUBLIC WORKS**  
51 GROVE STREET  
ARLINGTON, MA 02476

Phone: 781-316-3320  
Fax: 781-316-3281

---

**BID 22-39: 2022 LEAD WATER SERVICE REPLACEMENT PROJECT –  
VARIOUS LOCATIONS**

APPENDIX 1:

List of Addresses.....Page 1  
Site Photos.....Page 2  
Construction Details.....Page 38

Number	Location	Replacement Type
1	25 Aberdeen Road	Private
2	155 Brattle Street	Private
3	146 Gray Street	Private
4	29 Highland Ave	Private
5	15 Iroquois Road	Private
6	72 Overlook Road	Private
7	130 Park Ave Ext.	Private
8	5 Perkins Street	Private
9	66 Ronald Road	Private
10	413 Summer Street	Private
11	10 Sunset Road	Private
12	143 Washington Street	Private
13	33 Westminster Ave	Private
14	89 Wright Street	Private
15	31-33 Acton Street	Town
16	34 Ashland Street	Town
17	8 College Ave	Town
18	62 Dickson Ave	Town
19	226 Gray Street	Town
20	12 Harold Street	Town
21	44 Huntington Ave	Town
22	124 Newland Road	Town
23	18-20 Newport Street	Town
24	26-28 Newport Street	Town
25	175 Newport Street	Town
26	12 Puritan Road	Town
27	91 Quincy Street	Town
28	569 Summer Street	Town
29	75 Summit Street	Town
30	36 Udine Street	Town
31	154 Washington Street	Town
32	4 Dudley St. Pl.	Full
33	25 Medford Street	Full
34	460-468 Mass Ave	Full
35	10 Prentiss Road	Full
36	37 Westminster Ave	Full

**Private = Curb stop to water meter**

**Town = Curb stop to corporation stop at water main**

**Full = Corporation stop to water meter**

25 Aberdeen Road



31-33 Acton Street



34 Ashland Street



155 Brattle Street



8 College Ave



62 Dickson Ave





4 Dudley St. Pl.



146 Gray Street



226 Gray Street



12 Harold Street



29 Highland Ave



44 Huntington Road



15 Iroquois Road



460-468 Mass Ave

WEATFIXX  
ROW • SCULPT

JC JEWELERS

BubbleNation

CBD Store

© 2021 Google

© 2021 Google



25 Medford Street



124 Newland Road



18-20 Newport Street



26-28 Newport Street



175 Newport Street



72 Overlook Road



130 Park Ave. Ext.



5 Perkins Street





10 Prentiss Road



12 Puritan Road



91 Quincy Street



66 Ronald Road



413 Summer Street



© 2021 Google

569 Summer Street



75 Summit Street



10 Sunset Road





36 Udine Street



143 Washington Street



154 Washington Street



33 Westminster Ave



37 Westminster Ave



89 Wright Street



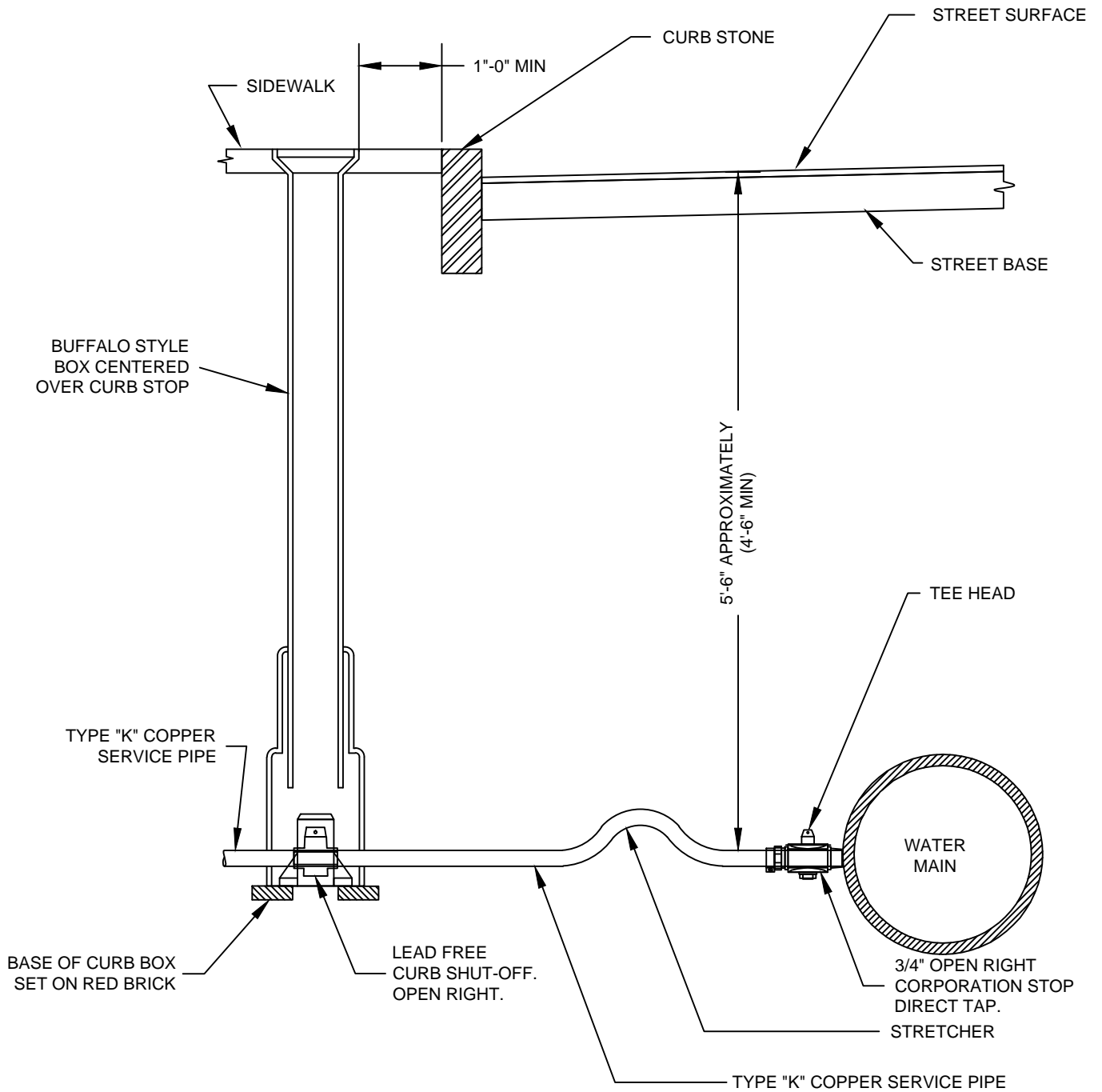

NOTE:

1. ALL INSTALLATIONS SHALL CONFORM TO TOWN OF ARLINGTON STANDARD WATER REGULATIONS & SPECIFICATIONS.

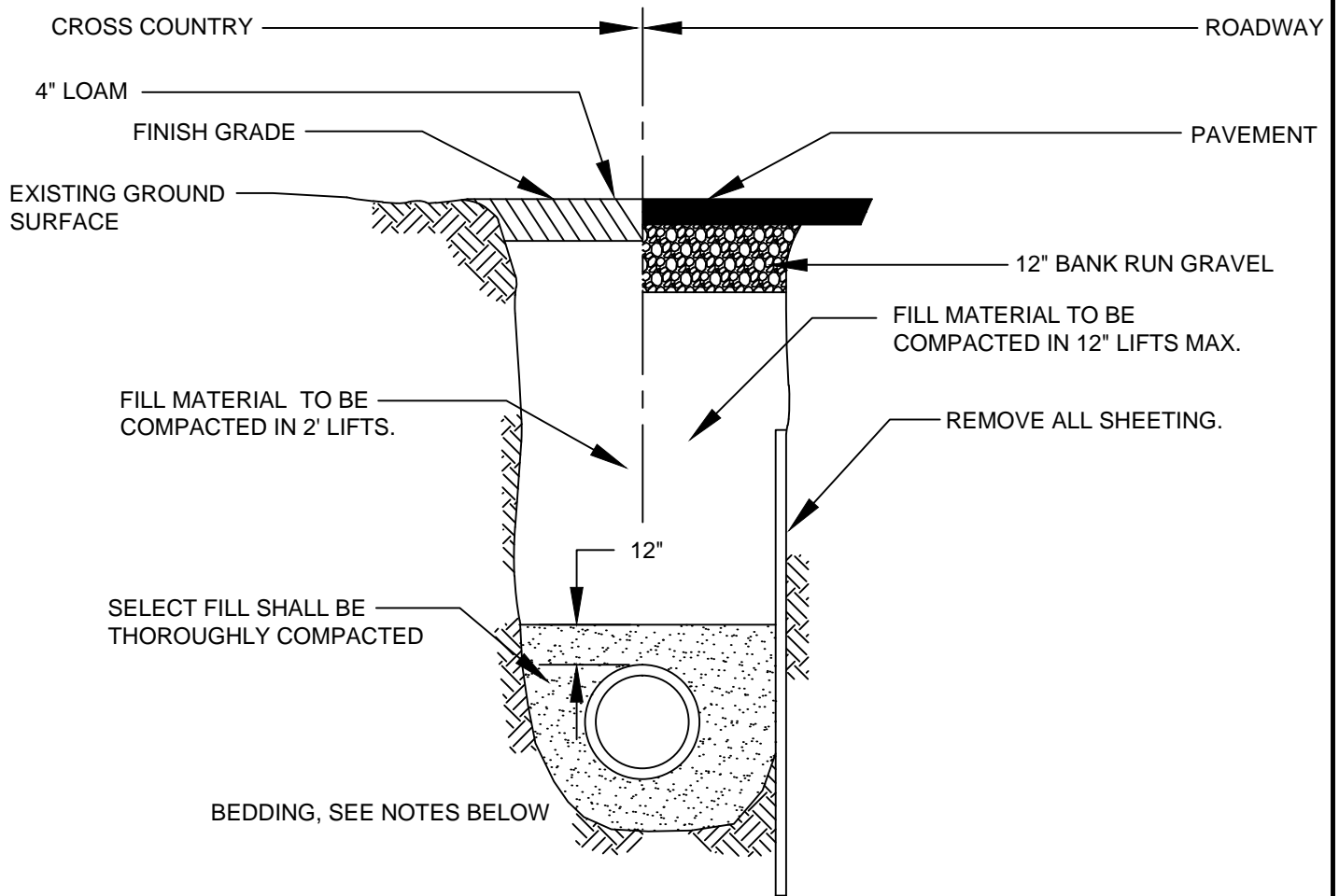

NOTE: 5'-0" MIN. COVER

NOTE:

1. ALL INSTALLATIONS SHALL CONFORM TO TOWN OF ARLINGTON STANDARD WATER REGULATIONS & SPECIFICATIONS.
2. TOWN OF ARLINGTON MAY REQUIRE FLOWABLE FILL AT ITS DISCRETION.
3. FOR LOCATIONS WHERE LEDGE IS NOT ENCOUNTERED IN TRENCH, PIPE SHALL BE LAID ON SAND BEDDING CONSISTENT WITH AWWA GUIDELINES.
4. FOR LOCATIONS WHERE LEDGE IS ENCOUNTERED, SAND BEDDING SHALL BE MINIMUM OF 12" THICK UNDER PIPE.
5. FILL MATERIAL SHALL BE COMPACTED TO 95% PROCTOR DENSITY.



TYPICAL WATER MAIN TRENCH DETAIL

OCT. 2014
NOT TO SCALE
REVISION
①

W-0006



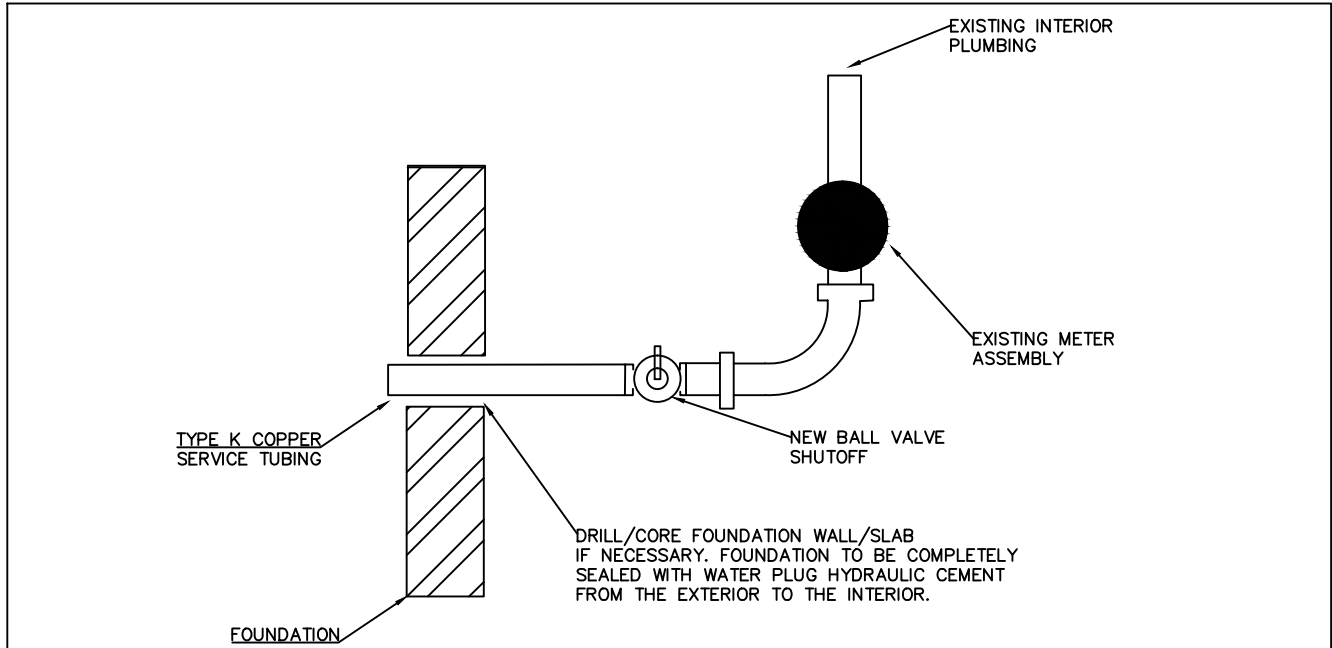

- NOTES:
1. CONTRACTOR IS RESPONSIBLE FOR ALL FITTING AND APPURTENANCES UP TO THE EXISTING WATER METER
  2. WATER SHALL BE FLUSHED BEFORE FINAL CONNECTION IS MADE
  3. ALL FITTING AND MATERIALS SHALL CONFORM TO ARLINGTON CONSTRUCTION SPECS



METER CONNECTION

AUG. 2022	W-0014
NOT TO SCALE	

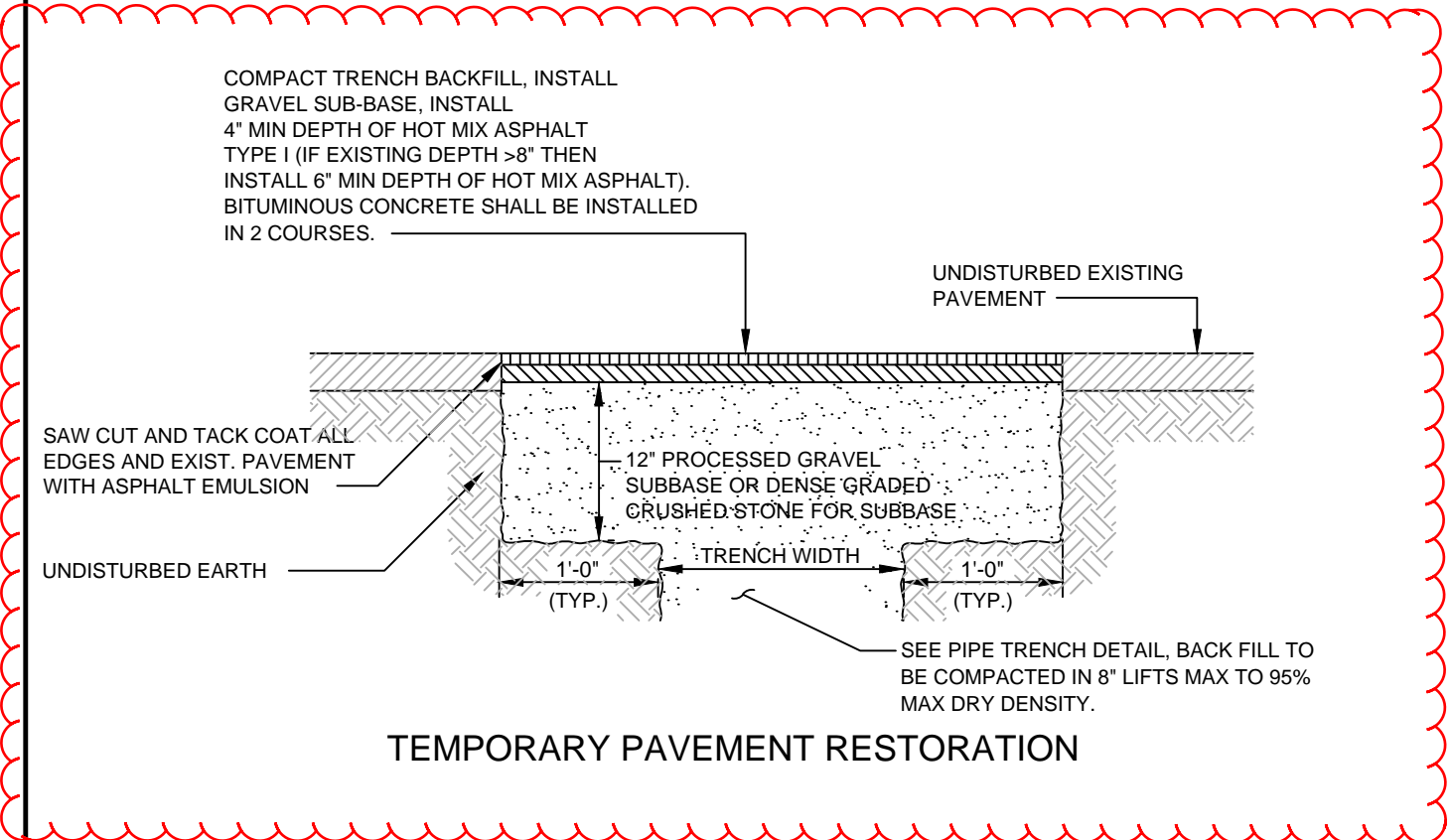
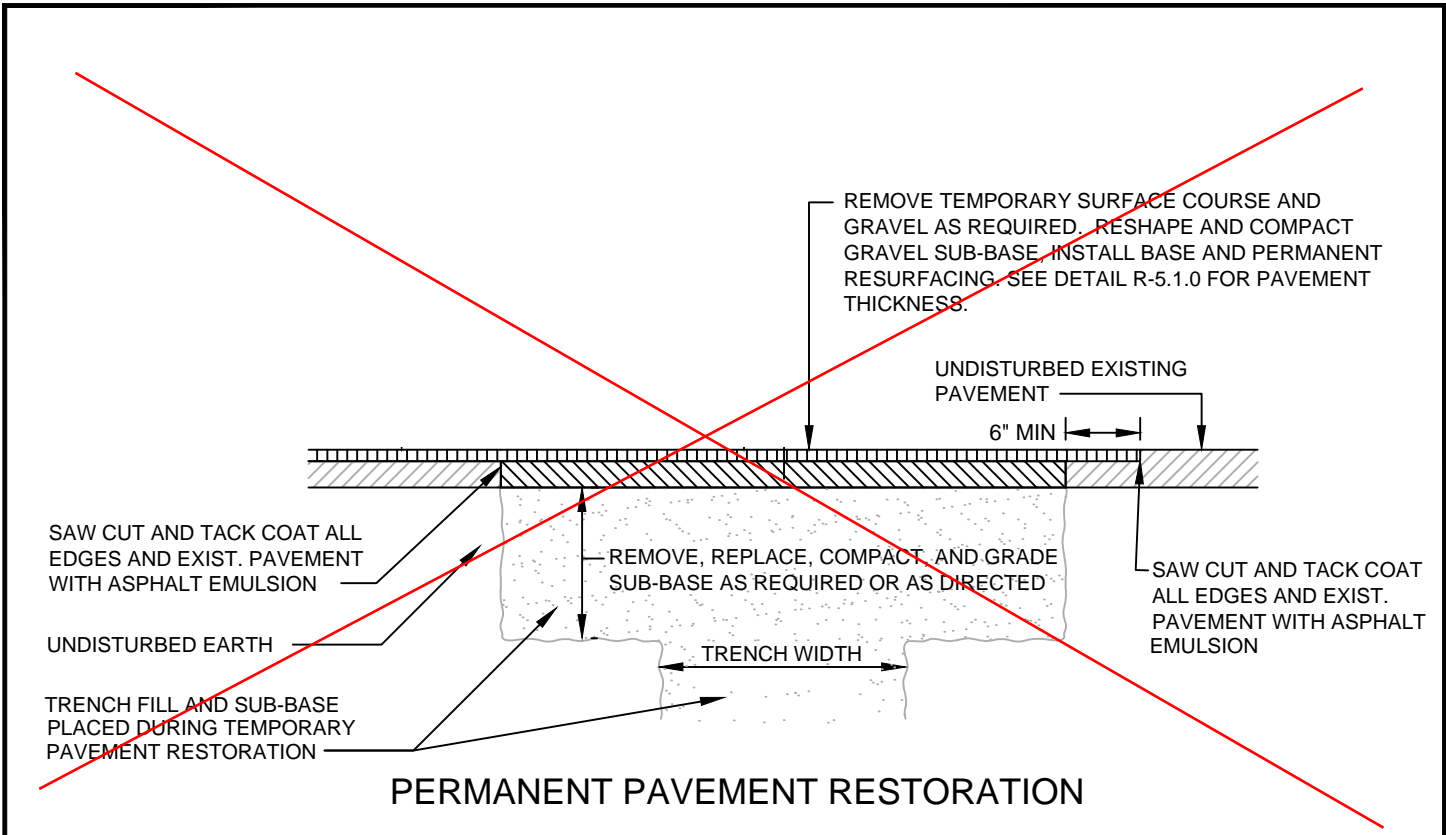

	<p align="center"><b>PAVEMENT DETAILS FOR TRENCH RESTORATION</b></p>	<p align="center">JAN. 2015</p>	<p align="center"><b>R-0018</b></p>
		<p align="center">NOT TO SCALE</p>	
		<p align="center">REVISION ①</p>	

## ADDENDUM

### INTRODUCTION

Notice: The Contract / Agreement to which this addendum is attached is made using federal assistance provided to the City of Medford ("Town" or "Owner"). <sup>[P]</sup><sub>[SEP]</sub>The following contractual provisions are hereby incorporated into the Contract. In the event of any conflict between the below provisions and other provisions of this Contract / Agreement, the provisions in this Addendum shall control. In the event of any inconsistency between the Davis-Bacon Wage Rates and any prevailing wage rates published by the Commonwealth of Massachusetts and applicable to this Contract / Agreement, the higher of the two wages shall apply.

### BREACH OF CONTRACTUAL AGREEMENT: ADMINISTRATIVE CONTRACTUAL, AND LEGAL REMEDIES; SANCTIONS AND PENALTIES

It is hereby understood and mutually agreed, by and between the Contractor and the Owner, that the date of beginning and the time for completion of the work to be done hereunder are ESSENTIAL CONDITIONS of the Contract; and it is further mutually understood and agreed that the work embraced in this Contract shall be commenced on a date to be specified in the "Notice to Proceed".

The Contractor agrees that said work shall be prosecuted regularly, diligently and uninterruptedly at such rate of progress as will ensure full completion thereof within the time specified. It is expressly understood and agreed, by and between the Contractor and the Owner, that the time for the completion of the work described herein is a reasonable time for the completion of the same, taking into consideration the average climatic range and usual industrial conditions prevailing in this locality.

If the said Contractor shall neglect, fail or refuse to complete the work within the time herein specified, or any extension thereof granted by the Owner, then the Contractor does hereby agree, as a partial consideration for the awarding of this Contract, to pay the Owner the amount specified in the Contract, not as a penalty but as liquidated damages for such Breach of Contract as hereinafter set forth, for each and every calendar day the Contractor shall be in default after the time stipulated in the Contract for completing the work.

The said amount of liquidated damages is fixed and agreed upon by and between the Contractor and the Owner because of the impracticability and extreme difficulty of fixing and ascertaining the actual damages the Owner would sustain in such event and said amount shall be retained from time to time by the Owner from current periodic estimates.

It is further agreed that time is of the essence of each and every portion of this Contract and of any specifications wherein a definite and certain length of time is fixed for the performance of any act whatsoever; and where under the Contract as additional time is allowed for the completion of any work, the new time limit fixed by such extension shall be of the essence of this Contract. Provided, that the Contractor shall not be charged with liquidated damages or any excess cost when the Owner determines

Town of Arlington  
730 Massachusetts Ave., Arlington Ma, 02476

that the Contractor is without fault and the Contractor's reasons for the time extensions are acceptable to the Owner; provided further, that the Contractor shall not be charged with liquidated damages or an excess cost when the delay in completion of the work is due to:

- A. Any preference, priority or allocation order duly issued by the government;
- B. Unforeseeable cause beyond the control and without fault of negligence of the Contractor, including, but not restricted to, acts of God or the public enemy, acts of the Owner, acts of another Contractor in the performance of a contract with the Owner, fires, floods, epidemics, quarantine restrictions, strikes, freight embargoes and severe weather;  
OR
- C. Any delays of subcontractors or suppliers occasioned by any of the causes specified in subsections (a) and (b) of this article.

Provided further, that the Contractor shall within ten (10) days from the beginning of such delay, unless the Owner shall grant a further period of time prior to the date of final settlement of the Contract, notify the Owner, in writing, of the causes of the delay, who shall ascertain the facts and extent of the delay and notify the Contractor within a reasonable time of its decision in the matter. The amount of liquidated damages for this project shall be Five Hundred Dollars (\$500.00) per consecutive calendar day.

#### TERMINATION FOR CAUSE AND CONVENIENCE

Where Contract exceeds \$10,000.00, the Owner may terminate this Contract by providing the Contractor and the Surety with ten (10) days written notice specifying the reasons for termination, as outlined below:

- A. Violation of any of the provisions of this Contract by the Contractor or any of their subcontractors;
- B. A determination by the Owner that the Contractor has engaged in fraud, waste, mismanagement, misuse of funds, or criminal activity with any funds provided by this Contract'
- C. Failure of the Contractor, for any reason, to fulfill in a timely and proper manner their obligations under this Contract, including compliance with applicable Federal, State and/or local law or regulations, and such procedures or guidelines as may be established;

In the event if any such termination, the Surety shall have the right to take over and perform the Contract; provided, however, that if the Surety does not commence performance within ten (10) days from the date of the mailing to such Surety of notice of termination, the Owner may take over the work and prosecute the same to completion at the expense of the Contractor, and the Contractor and their Surety shall be liable to the Owner for any excess cost occasioned by the Owner thereby, and in such event the Owner may take possession of and utilize in completing the work, such materials, appliances and plants as may be on the site of the work and necessary therefore.

If the Owner determines that a continuation of work on the project would endanger the life, health or safety of those working or living at or near the project site, or that immediate action is necessary to protect public funds and/or property, the Owner may suspend work or terminate this agreement by

Town of Arlington  
730 Massachusetts Ave., Arlington Ma, 02476

providing notice to the Contractor in the form of a telegram, mailgram, hand-carried letter, or other appropriate written means.

In addition, notwithstanding anything to the contrary in the Contract, the Owner may also terminate this Contract for its conveniences, including due to the lack of sufficient funds to complete the work. In such event, the Owner shall provide written notice of termination to the Contractor, and the Contractor shall thereupon cease all work other than work that is required to make the work and surrounding property safe, and the Owner shall pay the Contractor for all work performed in accordance with the terms of the Contract up to the date of the Contract, provided the Contractor shall not be entitled to any termination (or similar) damages or other costs and expenses that may be associated with a termination for convenience.

## EQUAL EMPLOYMENT CLAUSE

During the performance of this Contract, the Contractor agrees as follows:

- A. The Contractor will not discriminate against any employee or applicant for employment because of race, color, religion, sex, sexual orientation, gender identity, or national origin. The Contractor will take affirmative action to ensure that applicants are employed, and that employees are treated during employment without regard to their race, color, religion, sex, sexual orientation, gender identity, or national origin. Such action shall include, but not be limited to the following:
  1. Employment, upgrading, demotion, or transfer; recruitment or recruitment advertising; layoff or termination; rates of pay or other forms of compensation; and selection for training, including apprenticeship.
  2. The Contractor agrees to post in conspicuous places, available to employees and applicants for employment, notices to be provided setting forth the provisions of this nondiscrimination clause.
- B. The Contractor will, in all solicitations or advertisements for employees placed by or on behalf of the Contractor, state that all qualified applicants will receive consideration for employment without regard to race, color, religion, sex, sexual orientation, gender identity, or national origin.
- C. The Contractor will not discharge or in any other manner discriminate against any employee or applicant for employment because such employee or applicant has inquired about, discussed, or disclosed the compensation of the employee or applicant or another employee or applicant. This provision shall not apply to instances in which an employee who has access to the compensation information of other employees or applicants as a part of such employee's essential job functions discloses the compensation of such other employees or applicants to individuals who do not otherwise have access to such information, unless such disclosure is in response to a formal complaint or charge, in furtherance of an investigation, proceeding, hearing, or action, including an investigation conducted by the employer, or is consistent with the Contractor's legal duty to furnish information.
- D. The Contractor will send to each labor union or representative of workers with which he has a collective bargaining agreement or other contract or understanding, a notice to be provided advising the said labor union or workers' representatives of the Contractor's commitments under this section, and shall post copies of the notice in conspicuous places available to employees and applicants for employment.

- E. The Contractor will comply with all provisions of Executive Order 11246 of September 24, 1965, and of the rules, regulations, and relevant orders of the Secretary of Labor.
- F. The Contractor will furnish all information and reports required by Executive Order 11246 of September 24, 1965, and by rules, regulations, and orders of the Secretary of Labor, or pursuant thereto, and will permit access to his books, records, and accounts by the administering agency and the Secretary of Labor for purposes of investigation to ascertain compliance with such rules, regulations, and orders.
- G. In the event of the Contractor's noncompliance with the nondiscrimination clauses of this contract or with any of the said rules, regulations, or orders, this contract may be canceled, terminated, or suspended in whole or in part and the Contractor may be declared ineligible for further Government contracts or federally assisted construction contracts in accordance with procedures authorized in Executive Order 11246 of September 24, 1965, and such other sanctions may be imposed and remedies invoked as provided in Executive Order 11246 of September 24, 1965, or by rule, regulation, or order of the Secretary of Labor, or as otherwise provided by law.
- H. The Contractor will include the portion of the sentence immediately preceding paragraph and the provisions of paragraphs (1) through (8) in every subcontract or purchase order unless exempted by rules, regulations, or orders of the Secretary of Labor issued pursuant to section 204 of Executive Order 11246 of September 24, 1965, so that such provisions will be binding upon each subcontractor or vendor.<sup>2</sup> The Contractor will take such action with respect to any subcontract or purchase order as the administering agency may direct as a means of enforcing such provisions, including sanctions for noncompliance:

Provided, however, that in the event a Contractor becomes involved in, or is threatened with, litigation with a subcontractor or vendor as a result of such direction by the administering agency, the Contractor may request the United States to enter into such litigation to protect the interests of the United States.

## DAVIS-BACON ACT

### A. DAVIS-BACON PREVAILING WAGE

The Contractor acknowledges that the decision to award this contract is conditioned upon Contractor's acceptance of the wage determination, and upon continuing compliance with the Davis-Bacon Act (40 U.S.C. 3141-3144, and 3146-3148) as supplemented by Department of Labor regulations (29 CFR Part 5, "Labor Standards Provisions Applicable to Contracts Covering Federally Financed and Assisted Construction"). Pursuant to the Davis-Bacon Act, Contractors must be required to pay wages to laborers and mechanics at a rate not less than the prevailing wages specified in the Secretary of Labor's wage determinations, incorporated into this Contract and enclosed as \_\_\_\_\_<sup>1</sup>. Contractor further acknowledges

---

<sup>1</sup> Insert reference to location of Davis Bacon Prevailing Wage Determination in Contract

Town of Arlington  
730 Massachusetts Ave., Arlington Ma, 02476

and understands that Contractor shall be required to pay wages not less than once a week.

**B. DAVIS-BACON PREVAILING WAGE CERTIFICATION**

Contractor certifies that Contractor and all subcontractors shall provide certified payroll affidavits verifying compliance with G.L. c.149 §§ 26–27H, the federal Davis Bacon Act, and other related acts.

\_\_\_\_\_  
Signature of Contractor's authorized official      Date

\_\_\_\_\_  
Name (printed)

\_\_\_\_\_  
Date (printed)

Town of Arlington  
730 Massachusetts Ave., Arlington Ma, 02476

## CONTRACT WORK HOURS AND SAFETY STANDARDS ACT (40 U.S.C. § 3701–3708)

Where the Contract: (1) is awarded for a sum exceeding \$100,000; and (2) will involve the employment of mechanics or laborers, the Contractor shall comply with the Contract Work Hours and Safety Standards Act, 40 U.S.C. 3702 and 3704, as supplemented by Department of Labor regulations (29 CFR Part 5).

Pursuant to 40 U.S.C. 3702 of the Contract Work Hours and Safety Standards Act, Contractor shall be required to compute the wages of every mechanic and laborer on the basis of a standard work week of 40 hours. Work in excess of the standard work week is permissible provided that the worker is compensated at a rate of not less than one and a half times the basic rate of pay for all hours worked in excess of 40 hours in the work week. The requirements of 40 U.S.C. 3704 shall apply construction work and provide that no laborer or mechanic must be required to work in surroundings or under working conditions which are unsanitary, hazardous or dangerous. These requirements do not apply to the purchases of supplies or materials or articles ordinarily available on the open market, or contracts for transportation or transmission of intelligence.

## RIGHTS TO INVENTIONS MADE UNDER A CONTRACT OR AGREEMENT

In the event that this Contract is funded by a Federal award meeting the definition of “funding agreement” under 37 C.F.R. § 401.2(a) and the recipient or subrecipient wishes to enter into a contract with a small business firm or nonprofit organization regarding the substitution of parties, assignment or performance of experimental, developmental, or research work under that “funding agreement,” the recipient or subrecipient must comply with the requirements of 37

C.F.R. Part 401, “Rights to Inventions Made by Nonprofit Organizations and Small Business Firms Under Government Grants, Contracts and Cooperative Agreements,” and any implementing regulations issued by the awarding agency.

## CLEAN AIR ACT

Contractor shall comply with all applicable standards, orders or regulations issued<sup>[P]</sup><sub>[SEP]</sub> pursuant to the Clean Air Act (42 U.S.C. 7401–7671q) and the Federal Water Pollution Control Act as amended (33 U.S.C. 1251–1387). Contractor further acknowledges and understands that Contractor shall be required to report any violations of said acts to the Federal awarding agency and the Regional Office of the Environmental Protection Agency.

## DEBARMENT AND SUSPENSION (EXECUTIVE ORDERS 12549 AND 12689)



Town of Arlington  
730 Massachusetts Ave., Arlington Ma, 02476

Contractor certifies that neither Contractor nor any employer or subcontractor is a party listed on the government wide exclusions in the System for Award Management (SAM), in accordance with the OMB guidelines at 2 CFR 180 that implement Executive Orders 12549 (3 CFR part 1986 Comp., p. 189) and 12689 (3 CFR part 1989 Comp., p. 235), "Debarment and Suspension." SAM Exclusions contains the names of parties debarred, suspended, or otherwise excluded by agencies, as well as parties declared ineligible under statutory or regulatory authority other than Executive Order 12549.

## BYRD ANTI-LOBBYING; COPELAND "ANTI-KICKBACK" ACT (40 U.S.C. § 3145)

### A. BYRD ANTI-LOBBYING AMENDMENT

Contractor certifies that it will not and has not used Federal appropriated funds to pay any person or organization for influencing or attempting to influence an officer or employee of any agency, a member of Congress, officer or employee of Congress, or an employee of a member of Congress in connection with obtaining any Federal contract, grant or any other award covered by 31 U.S.C. 1352. <sup>[P]</sup><sub>SEP</sub> Contractor further understands and acknowledges that it shall disclose any lobbying with non-Federal funds that takes place in connection with obtaining any Federal award. Such disclosures shall be forwarded from tier to tier up to the non-Federal award.

### B. COPELAND "ANTI-KICKBACK" ACT

Contractor acknowledges and understands that the awarding of this contract is conditioned upon Contractor's compliance with the Federal Copeland "Anti-Kickback" Act (40 U.S.C. 3145), as supplemented by Department of Labor regulations (29 CFR Part 3, "Contractors and Subcontractors on Public Building or Public Work Financed in Whole or in Part by Loans or Grants from the United States"). The Act provides that each Contractor or subrecipient must be prohibited from inducing, by any means, any person employed in the construction, completion, or repair of public work, to give up any part of the compensation to which he or she is otherwise entitled. The non-Federal entity must report all suspected or reported violations to the Federal awarding agency.

### C. BYRD ANTI-LOBBYING AMENDMENT: REQUIRED CERTIFICATION FOR AWARDS EXCEEDING \$100,000

The undersigned certifies, to the best of their knowledge and belief, that:

1. No Federal appropriated funds have been paid or will be paid, by or on behalf of the undersigned, to any person for influencing or attempting to influence an officer or employee of an agency, a Member of Congress, an officer or employee of Congress, or an employee of a Member of Congress in connection with the awarding of any Federal contract, the making of any Federal grant, the making of any Federal loan, the entering into of any cooperative agreement, and the extension, continuation, renewal, amendment, or modification of any Federal contract, grant, loan, or cooperative agreement.
2. If any funds other than Federal appropriated funds have been paid or will be paid to any person for influencing or attempting to influence an officer or employee of any

Town of Arlington  
730 Massachusetts Ave., Arlington Ma, 02476

agency, a Member of Congress, an officer or employee of Congress, or an employee of a Member of Congress in connection with this Federal contract, grant, loan, or cooperative agreement, the undersigned shall complete and submit Standard Form-LLL, "Disclosure Form to Report Lobbying," in accordance with its instructions.<sup>2</sup>

3. The undersigned shall require that the language of this certification be included in the award documents for all subawards at all tiers (including subcontracts, subgrants, and contracts under grants, loans, and cooperative agreements) and that all contractors shall certify and disclose accordingly.

This certification is a material representation of fact upon which reliance was placed when this transaction was made or entered into. Submission of this certification is a prerequisite for making or entering into this transaction imposed by section 1352, title 31, U.S. Code. Any person who fails to file the required certification shall be subject to a civil penalty of not less than \$10,000 and not more than \$100,000 for each such failure.

Bidder certifies or affirms the truthfulness and accuracy of each statement of its certification and disclosure, if any. In addition, the bidding party understands and agrees that the provisions of 31 U.S.C. Ch. 38, Administrative Remedies for False Claims and Statements, apply to this certification and disclosure, if any.

\_\_\_\_\_  
Signature of Contractor's authorized official                      Date

\_\_\_\_\_  
Name (printed)

\_\_\_\_\_  
Date (printed)

## PROCUREMENT OF RECOVERED MATERIALS (2 C.F.R. § 200.323)

Contractor acknowledges and understands that, in performing the work specified under this contract, Contractor shall be required to comply with Section 6002 of the Solid Waste Disposal Act, as amended by the Resource Conservation and Recovery Act. The requirements of Section 6002 include procuring only items designated in guidelines of the Environmental Protection Agency (EPA) at 40 CFR part 247 that contain the highest percentage of recovered materials practicable, consistent with maintaining a satisfactory level of competition, where the purchase price of the item exceeds \$10,000 or the value of the quantity acquired during the preceding fiscal year exceeded \$10,000; procuring solid waste management services in a manner that maximizes energy and resource recovery; and establishing an affirmative procurement program for procurement of recovered materials identified in the EPA guidelines.

<sup>2</sup> Standard Form-LLL available at <https://www.grants.gov/web/grants/forms/post-award-reporting-forms.html>.

## PROHIBITION ON CERTAIN TELECOMMUNICATIONS AND VIDEO SURVEILLANCE SERVICES OR EQUIPMENT (2 C.F.R. § 200.216);

Contractor certifies that it shall not procure or obtain equipment, services, or systems that uses covered telecommunications equipment or services as a substantial or essential component of any system, or as critical technology as part of any system. As described in Public Law 115–232, section 889, covered telecommunications equipment is telecommunications equipment produced by Huawei Technologies Company or ZTE Corporation (or any subsidiary or affiliate of such entities).

- i. For the purpose of public safety, security of government facilities, physical security surveillance of critical infrastructure, and other national security purposes, video surveillance and telecommunications equipment produced by Hytera Communications Corporation, Hangzhou Hikvision Digital Technology Company, or Dahua Technology Company (or any subsidiary or affiliate of such entities);
- ii. Telecommunications or video surveillance services provided by such entities or using such equipment;
- iii. Telecommunications or video surveillance equipment or services produced or provided by an entity that the Secretary of Defense, in consultation with the Director of the National Intelligence or the Director of the Federal Bureau of Investigation, reasonably believes to be an entity owned or controlled by, or otherwise connected to, the government of a covered foreign country.

## DOMESTIC PREFERENCES FOR PROCUREMENTS (2 C.F.R. § 200.322)

- A. As appropriate and to the extent consistent with law, the non-Federal entity should, to the greatest extent practicable under a Federal award, provide a preference for the purchase, acquisition, or use of goods, products, or materials produced in the United States (including but not limited to iron, aluminum, steel, cement, and other manufactured products). The requirements of this section must be included in all subawards including all contracts and purchase orders for work or products under this award.
- B. For purposes of this section:
  1. “Produced in the United States” means, for iron and steel products, that all manufacturing processes, from the initial melting stage through the application of coatings, occurred in the United States.
  2. “Manufactured products” means items and construction materials composed in whole or in part of non-ferrous metals such as aluminum; plastics and polymer-based products such as polyvinyl chloride pipe; aggregates such as concrete; glass, including optical fiber; and lumber.

## Applicability

The Project or Program to which the construction work covered by this contract pertains is being assisted by the United States of America and the following Federal Labor Standards Provisions are included in this Contract pursuant to the provisions applicable to such Federal assistance.

**A. 1. (i) Minimum Wages.** All laborers and mechanics employed or working upon the site of the work, will be paid unconditionally and not less often than once a week, and without subsequent deduction or rebate on any account (except such payroll deductions as are permitted by regulations issued by the Secretary of Labor under the Copeland Act (29 CFR Part 3), the full amount of wages and bona fide fringe benefits (or cash equivalents thereof) due at time of payment computed at rates not less than those contained in the wage determination of the Secretary of Labor which is attached hereto and made a part hereof, regardless of any contractual relationship which may be alleged to exist between the contractor and such laborers and mechanics. Contributions made or costs reasonably anticipated for bona fide fringe benefits under Section I(b)(2) of the Davis-Bacon Act on behalf of laborers or mechanics are considered wages paid to such laborers or mechanics, subject to the provisions of 29 CFR 5.5(a)(1)(iv); also, regular contributions made or costs incurred for more than a weekly period (but not less often than quarterly) under plans, funds, or programs, which cover the particular weekly period, are deemed to be constructively made or incurred during such weekly period. Such laborers and mechanics shall be paid the appropriate wage rate and fringe benefits on the wage determination for the classification of work actually performed, without regard to skill, except as provided in 29 CFR 5.5(a)(4). Laborers or mechanics performing work in more than one classification may be compensated at the rate specified for each classification for the time actually worked therein: Provided, That the employer's payroll records accurately set forth the time spent in each classification in which work is performed. The wage determination (including any additional classification and wage rates conformed under 29 CFR 5.5(a)(1)(ii) and the Davis-Bacon poster (WH-1321) shall be posted at all times by the contractor and its subcontractors at the site of the work in a prominent and accessible, place where it can be easily seen by the workers.

**(ii) (a)** Any class of laborers or mechanics which is not listed in the wage determination and which is to be employed under the contract shall be classified in conformance with the wage determination. HUD shall approve an additional classification and wage rate and fringe benefits therefor only when the following criteria have been met:

**(1)** The work to be performed by the classification requested is not performed by a classification in the wage determination; and

**(2)** The classification is utilized in the area by the construction industry; and

**(3)** The proposed wage rate, including any bona fide fringe benefits, bears a reasonable relationship to the wage rates contained in the wage determination.

**(b)** If the contractor and the laborers and mechanics to be employed in the classification (if known), or their representatives, and HUD or its designee agree on the classification and wage rate (including the amount designated for fringe benefits where appropriate), a report of the action taken shall be sent by HUD or its designee to the Administrator of the Wage and Hour Division, Employment Standards Administration, U.S. Department of Labor, Washington, D.C. 20210. The Administrator, or an authorized representative, will approve, modify, or disapprove every additional classification action within 30 days of receipt and so advise HUD or its designee or will notify HUD or its designee within the 30-day period that additional time is necessary. (Approved by the Office of Management and Budget under OMB control number 1215-0140.)

**(c)** In the event the contractor, the laborers or mechanics to be employed in the classification or their representatives, and HUD or its designee do not agree on the proposed classification and wage rate (including the amount designated for fringe benefits, where appropriate), HUD or its designee shall refer the questions, including the views of all interested parties and the recommendation of HUD or its designee, to the Administrator for determination. The Administrator, or an authorized representative, will issue a determination within 30 days of receipt and so advise HUD or its designee or will notify HUD or its designee within the 30-day period that additional time is necessary. (Approved by the Office of Management and Budget under OMB Control Number 1215-0140.)

**(d)** The wage rate (including fringe benefits where appropriate) determined pursuant to subparagraphs (1)(ii)(b) or (c) of this paragraph, shall be paid to all workers performing work in the classification under this contract from the first day on which work is performed in the classification.

**(iii)** Whenever the minimum wage rate prescribed in the contract for a class of laborers or mechanics includes a fringe benefit which is not expressed as an hourly rate, the contractor shall either pay the benefit as stated in the wage determination or shall pay another bona fide fringe benefit or an hourly cash equivalent thereof.

**(iv)** If the contractor does not make payments to a trustee or other third person, the contractor may consider as part

of the wages of any laborer or mechanic the amount of any costs reasonably anticipated in providing bona fide fringe benefits under a plan or program, Provided, That the Secretary of Labor has found, upon the written request of the contractor, that the applicable standards of the Davis-Bacon Act have been met. The Secretary of Labor may require the contractor to set aside in a separate account assets for the meeting of obligations under the plan or program. (Approved by the Office of Management and Budget under OMB Control Number 1215-0140.)

**2. Withholding.** HUD or its designee shall upon its own action or upon written request of an authorized representative of the Department of Labor withhold or cause to be withheld from the contractor under this contract or any other Federal contract with the same prime contractor, or any other Federally-assisted contract subject to Davis-Bacon prevailing wage requirements, which is held by the same prime contractor so much of the accrued payments or advances as may be considered necessary to pay laborers and mechanics, including apprentices, trainees and helpers, employed by the contractor or any subcontractor the full amount of wages required by the contract. In the event of failure to pay any laborer or mechanic, including any apprentice, trainee or helper, employed or working on the site of the work, all or part of the wages required by the contract, HUD or its designee may, after written notice to the contractor, sponsor, applicant, or owner, take such action as may be necessary to cause the suspension of any further payment, advance, or guarantee of funds until such violations have ceased. HUD or its designee may, after written notice to the contractor, disburse such amounts withheld for and on account of the contractor or subcontractor to the respective employees to whom they are due. The Comptroller General shall make such disbursements in the case of direct Davis-Bacon Act contracts.

**3. (i) Payrolls and basic records.** Payrolls and basic records relating thereto shall be maintained by the contractor during the course of the work preserved for a period of three years thereafter for all laborers and mechanics working at the site of the work. Such records shall contain the name, address, and social security number of each such worker, his or her correct classification, hourly rates of wages paid (including rates of contributions or costs anticipated for bona fide fringe benefits or cash equivalents thereof of the types described in Section 1(b)(2)(B) of the Davis-bacon Act), daily and weekly number of hours worked, deductions made and actual wages paid. Whenever the Secretary of Labor has found under 29 CFR 5.5 (a)(1)(iv) that the wages of any laborer or mechanic include the amount of any costs reasonably anticipated in providing benefits under a plan or program described in Section 1(b)(2)(B) of the Davis-Bacon Act, the contractor shall maintain records which show that the commitment to provide such benefits is enforceable, that the plan or program is financially responsible, and that the plan or program has been

communicated in writing to the laborers or mechanics affected, and records which show the costs anticipated or the actual cost incurred in providing such benefits. Contractors employing apprentices or trainees under approved programs shall maintain written evidence of the registration of apprenticeship programs and certification of trainee programs, the registration of the apprentices and trainees, and the ratios and wage rates prescribed in the applicable programs. (Approved by the Office of Management and Budget under OMB Control Numbers 1215-0140 and 1215-0017.)

**(ii) (a)** The contractor shall submit weekly for each week in which any contract work is performed a copy of all payrolls to HUD or its designee if the agency is a party to the contract, but if the agency is not such a party, the contractor will submit the payrolls to the applicant sponsor, or owner, as the case may be, for transmission to HUD or its designee. The payrolls submitted shall set out accurately and completely all of the information required to be maintained under 29 CFR 5.5(a)(3)(i) except that full social security numbers and home addresses shall not be included on weekly transmittals. Instead the payrolls shall only need to include an individually identifying number for each employee (e.g., the last four digits of the employee's social security number). The required weekly payroll information may be submitted in any form desired. Optional Form WH-347 is available for this purpose from the Wage and Hour Division Web site at <http://www.dol.gov/esa/whd/forms/wh347instr.htm> or its successor site. The prime contractor is responsible for the submission of copies of payrolls by all subcontractors. Contractors and subcontractors shall maintain the full social security number and current address of each covered worker, and shall provide them upon request to HUD or its designee if the agency is a party to the contract, but if the agency is not such a party, the contractor will submit the payrolls to the applicant sponsor, or owner, as the case may be, for transmission to HUD or its designee, the contractor, or the Wage and Hour Division of the Department of Labor for purposes of an investigation or audit of compliance with prevailing wage requirements. It is not a violation of this subparagraph for a prime contractor to require a subcontractor to provide addresses and social security numbers to the prime contractor for its own records, without weekly submission to HUD or its designee. (Approved by the Office of Management and Budget under OMB Control Number 1215-0149.)

**(b)** Each payroll submitted shall be accompanied by a "Statement of Compliance," signed by the contractor or subcontractor or his or her agent who pays or supervises the payment of the persons employed under the contract and shall certify the following:

**(1)** That the payroll for the payroll period contains the information required to be provided under 29 CFR 5.5 (a)(3)(ii), the appropriate information is being maintained under 29 CFR 5.5(a)(3)(i), and that such information is correct and complete;

(2) That each laborer or mechanic (including each helper, apprentice, and trainee) employed on the contract during the payroll period has been paid the full weekly wages earned, without rebate, either directly or indirectly, and that no deductions have been made either directly or indirectly from the full wages earned, other than permissible deductions as set forth in 29 CFR Part 3;

(3) That each laborer or mechanic has been paid not less than the applicable wage rates and fringe benefits or cash equivalents for the classification of work performed, as specified in the applicable wage determination incorporated into the contract.

(c) The weekly submission of a properly executed certification set forth on the reverse side of Optional Form WH-347 shall satisfy the requirement for submission of the "Statement of Compliance" required by subparagraph A.3.(ii)(b).

(d) The falsification of any of the above certifications may subject the contractor or subcontractor to civil or criminal prosecution under Section 1001 of Title 18 and Section 231 of Title 31 of the United States Code.

(iii) The contractor or subcontractor shall make the records required under subparagraph A.3.(i) available for inspection, copying, or transcription by authorized representatives of HUD or its designee or the Department of Labor, and shall permit such representatives to interview employees during working hours on the job. If the contractor or subcontractor fails to submit the required records or to make them available, HUD or its designee may, after written notice to the contractor, sponsor, applicant or owner, take such action as may be necessary to cause the suspension of any further payment, advance, or guarantee of funds. Furthermore, failure to submit the required records upon request or to make such records available may be grounds for debarment action pursuant to 29 CFR 5.12.

#### 4. Apprentices and Trainees.

(i) **Apprentices.** Apprentices will be permitted to work at less than the predetermined rate for the work they performed when they are employed pursuant to and individually registered in a bona fide apprenticeship program registered with the U.S. Department of Labor, Employment and Training Administration, Office of Apprenticeship Training, Employer and Labor Services, or with a State Apprenticeship Agency recognized by the Office, or if a person is employed in his or her first 90 days of probationary employment as an apprentice in such an apprenticeship program, who is not individually registered in the program, but who has been certified by the Office of Apprenticeship Training, Employer and Labor Services or a State Apprenticeship Agency (where appropriate) to be eligible for probationary employment as an apprentice. The allowable ratio of apprentices to journeymen on the job site in any craft classification shall not be greater than the ratio permitted to the contractor as to the entire work force under the registered program. Any worker listed on a payroll at an apprentice wage rate, who

is not registered or otherwise employed as stated above, shall be paid not less than the applicable wage rate on the wage determination for the classification of work actually performed. In addition, any apprentice performing work on the job site in excess of the ratio permitted under the registered program shall be paid not less than the applicable wage rate on the wage determination for the work actually performed. Where a contractor is performing construction on a project in a locality other than that in which its program is registered, the ratios and wage rates (expressed in percentages of the journeyman's hourly rate) specified in the contractor's or subcontractor's registered program shall be observed. Every apprentice must be paid at not less than the rate specified in the registered program for the apprentice's level of progress, expressed as a percentage of the journeymen hourly rate specified in the applicable wage determination. Apprentices shall be paid fringe benefits in accordance with the provisions of the apprenticeship program. If the apprenticeship program does not specify fringe benefits, apprentices must be paid the full amount of fringe benefits listed on the wage determination for the applicable classification. If the Administrator determines that a different practice prevails for the applicable apprentice classification, fringes shall be paid in accordance with that determination. In the event the Office of Apprenticeship Training, Employer and Labor Services, or a State Apprenticeship Agency recognized by the Office, withdraws approval of an apprenticeship program, the contractor will no longer be permitted to utilize apprentices at less than the applicable predetermined rate for the work performed until an acceptable program is approved.

(ii) **Trainees.** Except as provided in 29 CFR 5.16, trainees will not be permitted to work at less than the predetermined rate for the work performed unless they are employed pursuant to and individually registered in a program which has received prior approval, evidenced by formal certification by the U.S. Department of Labor, Employment and Training Administration. The ratio of trainees to journeymen on the job site shall not be greater than permitted under the plan approved by the Employment and Training Administration. Every trainee must be paid at not less than the rate specified in the approved program for the trainee's level of progress, expressed as a percentage of the journeyman hourly rate specified in the applicable wage determination. Trainees shall be paid fringe benefits in accordance with the provisions of the trainee program. If the trainee program does not mention fringe benefits, trainees shall be paid the full amount of fringe benefits listed on the wage determination unless the Administrator of the Wage and Hour Division determines that there is an apprenticeship program associated with the corresponding journeyman wage rate on the wage determination which provides for less than full fringe benefits for apprentices. Any employee listed on the payroll at a trainee rate who is not registered and participating in a training plan approved by

the Employment and Training Administration shall be paid not less than the applicable wage rate on the wage determination for the work actually performed. In addition, any trainee performing work on the job site in excess of the ratio permitted under the registered program shall be paid not less than the applicable wage rate on the wage determination for the work actually performed. In the event the Employment and Training Administration withdraws approval of a training program, the contractor will no longer be permitted to utilize trainees at less than the applicable predetermined rate for the work performed until an acceptable program is approved.

**(iii) Equal employment opportunity.** The utilization of apprentices, trainees and journeymen under 29 CFR Part 5 shall be in conformity with the equal employment opportunity requirements of Executive Order 11246, as amended, and 29 CFR Part 30.

**5. Compliance with Copeland Act requirements.** The contractor shall comply with the requirements of 29 CFR Part 3 which are incorporated by reference in this contract

**6. Subcontracts.** The contractor or subcontractor will insert in any subcontracts the clauses contained in subparagraphs 1 through 11 in this paragraph A and such other clauses as HUD or its designee may by appropriate instructions require, and a copy of the applicable prevailing wage decision, and also a clause requiring the subcontractors to include these clauses in any lower tier subcontracts. The prime contractor shall be responsible for the compliance by any subcontractor or lower tier subcontractor with all the contract clauses in this paragraph.

**7. Contract termination; debarment.** A breach of the contract clauses in 29 CFR 5.5 may be grounds for termination of the contract and for debarment as a contractor and a subcontractor as provided in 29 CFR 5.12.

**8. Compliance with Davis-Bacon and Related Act Requirements.** All rulings and interpretations of the Davis-Bacon and Related Acts contained in 29 CFR Parts 1, 3, and 5 are herein incorporated by reference in this contract

**9. Disputes concerning labor standards.** Disputes arising out of the labor standards provisions of this contract shall not be subject to the general disputes clause of this contract. Such disputes shall be resolved in accordance with the procedures of the Department of Labor set forth in 29 CFR Parts 5, 6, and 7. Disputes within the meaning of this clause include disputes between the contractor (or any of its subcontractors) and HUD or its designee, the U.S. Department of Labor, or the employees or their representatives.

**10. (i) Certification of Eligibility.** By entering into this contract the contractor certifies that neither it (nor he or she) nor any person or firm who has an interest in the contractor's firm is a person or firm ineligible to be awarded Government contracts by virtue of Section 3(a) of the Davis-Bacon Act or 29 CFR 5.12(a)(1) or to be

awarded HUD contracts or participate in HUD programs pursuant to 24 CFR Part 24.

**(ii)** No part of this contract shall be subcontracted to any person or firm ineligible for award of a Government contract by virtue of Section 3(a) of the Davis-Bacon Act or 29 CFR 5.12(a)(1) or to be awarded HUD contracts or participate in HUD programs pursuant to 24 CFR Part 24.

**(iii)** The penalty for making false statements is prescribed in the U.S. Criminal Code, 18 U.S.C. 1001. Additionally, U.S. Criminal Code, Section 1 01 0, Title 18, U.S.C., "Federal Housing Administration transactions", provides in part: "Whoever, for the purpose of . . . influencing in any way the action of such Administration..... makes, utters or publishes any statement knowing the same to be false..... shall be fined not more than \$5,000 or imprisoned not more than two years, or both."

**11. Complaints, Proceedings, or Testimony by Employees.** No laborer or mechanic to whom the wage, salary, or other labor standards provisions of this Contract are applicable shall be discharged or in any other manner discriminated against by the Contractor or any subcontractor because such employee has filed any complaint or instituted or caused to be instituted any proceeding or has testified or is about to testify in any proceeding under or relating to the labor standards applicable under this Contract to his employer.

**B. Contract Work Hours and Safety Standards Act.** The provisions of this paragraph B are applicable where the amount of the prime contract exceeds \$100,000. As used in this paragraph, the terms "laborers" and "mechanics" include watchmen and guards.

**(1) Overtime requirements.** No contractor or subcontractor contracting for any part of the contract work which may require or involve the employment of laborers or mechanics shall require or permit any such laborer or mechanic in any workweek in which the individual is employed on such work to work in excess of 40 hours in such workweek unless such laborer or mechanic receives compensation at a rate not less than one and one-half times the basic rate of pay for all hours worked in excess of 40 hours in such workweek.

**(2) Violation; liability for unpaid wages; liquidated damages.** In the event of any violation of the clause set forth in subparagraph (1) of this paragraph, the contractor and any subcontractor responsible therefor shall be liable for the unpaid wages. In addition, such contractor and subcontractor shall be liable to the United States (in the case of work done under contract for the District of Columbia or a territory, to such District or to such territory), for liquidated damages. Such liquidated damages shall be computed with respect to each individual laborer or mechanic, including watchmen and guards, employed in violation of the clause set forth in subparagraph (1) of this paragraph, in the sum of \$10 for each calendar day on which such individual was required or permitted to work in excess of the standard workweek of 40 hours without payment of the overtime wages required by the clause set forth in subparagraph (1) of this paragraph.

---

**(3) Withholding for unpaid wages and liquidated damages.** HUD or its designee shall upon its own action or upon written request of an authorized representative of the Department of Labor withhold or cause to be withheld, from any moneys payable on account of work performed by the contractor or subcontractor under any such contract or any other Federal contract with the same prime contract, or any other Federally-assisted contract subject to the Contract Work Hours and Safety Standards Act which is held by the same prime contractor such sums as may be determined to be necessary to satisfy any liabilities of such contractor or subcontractor for unpaid wages and liquidated damages as provided in the clause set forth in subparagraph (2) of this paragraph.

**(4) Subcontracts.** The contractor or subcontractor shall insert in any subcontracts the clauses set forth in subparagraph (1) through (4) of this paragraph and also a clause requiring the subcontractors to include these clauses in any lower tier subcontracts. The prime contractor shall be responsible for compliance by any subcontractor or lower tier subcontractor with the clauses set forth in subparagraphs (1) through (4) of this paragraph.

**C. Health and Safety.** The provisions of this paragraph C are applicable where the amount of the prime contract exceeds \$100,000.

**(1)** No laborer or mechanic shall be required to work in surroundings or under working conditions which are unsanitary, hazardous, or dangerous to his health and safety as determined under construction safety and health standards promulgated by the Secretary of Labor by regulation.

**(2)** The Contractor shall comply with all regulations issued by the Secretary of Labor pursuant to Title 29 Part 1926 and failure to comply may result in imposition of sanctions pursuant to the Contract Work Hours and Safety Standards Act, (Public Law 91-54, 83 Stat 96). 40 USC 3701 et seq.

**(3)** The contractor shall include the provisions of this paragraph in every subcontract so that such provisions will be binding on each subcontractor. The contractor shall take such action with respect to any subcontractor as the Secretary of Housing and Urban Development or the Secretary of Labor shall direct as a means of enforcing such provisions.



# Project Wage Rate Sheet

U.S. Department of Housing and Urban Development  
Office of Labor Relations

PROJECT NAME:			WAGE DECISION NUMBER/MODIFICATION NUMBER:			
PROJECT NUMBER:			PROJECT COUNTY:			
WORK CLASSIFICATION	BASIC HOURLY RATE (BHR)	FRINGE BENEFITS	TOTAL HOURLY WAGE RATE	LABORERS FRINGE BENEFITS:		\$ TOTAL WAGE
				GROUP #	BHR	
Bricklayers			\$			\$
Carpenters			\$			\$
Cement Masons			\$			\$
Drywall Hangers			\$			\$
Electricians			\$			\$
Iron Workers			\$			\$
Painters			\$	OPERATORS FRINGE BENEFITS:		\$ TOTAL WAGE
				GROUP #	BHR	
Plumbers			\$			\$
Roofers			\$			\$
Sheet Metal Workers			\$			\$
Soft Floor Layers			\$			\$
Tapers			\$			\$
Tile Setters			\$	TRUCK DRIVERS FRINGE BENEFITS:		\$ TOTAL WAGE
				GROUP #	BHR	
OTHER CLASSIFICATIONS						
			\$			\$
			\$			\$
			\$			\$
<b>ADDITIONAL CLASSIFICATIONS (HUD Form 4230-A)</b>						
WORK CLASSIFICATION	BASIC HOURLY RATE	FRINGE BENEFITS	TOTAL HOURLY WAGE RATE	DATE OF HUD SUBMISSION TO DOL	DATE OF DOL APPROVAL	
			\$			
			\$			
			\$			
			\$			

BY-LAWS OF THE TOWN OF ARLINGTON  
TITLE I  
ARTICLE 16

CONSTRUCTION PROJECTS

**Section 1. Women Work Force Participation**

Any Town board or official in charge of a construction or reconstruction project is required to include in the contract documents the following:

- A. Contractor shall maintain as a goal on this project a not less than five percent ratio of women work force to total project hours in both the general contract and each individual filed sub-bid contract, if applicable. The preceding sentence shall be included in all construction contracts whether entered into by the Town pursuant to the provisions of M.G.L. c. 149 or M.G. L. c 30, §39M et. seq. provided however, that if entered into under Chapter 30 same shall not be deemed to apply where the projected bid price as determined by the Director of Public Works is not likely to exceed \$200,000.
- B. A Labor Scheduling Table which will be used as a tool for achieving a range of women work force participation for the entire project in both the general contract and each individual filed sub-bid contract.

**Section 2. Equal Opportunity Goal Compliance**

Any Town board or official in charge of a construction or reconstruction project is required to include in the contract documents the following:

- A. Before starting work, the contractors (includes the general contractor, for itself and its subcontractors, as well as all filed sub-bid contractors, if applicable) will submit plans for achievement of the equal opportunity goals of the contract. All contractors will be required to make a good faith effort to achieve these goals. The plan will indicate if the contractors expect to achieve the requirements during the first quarter. If there are reasons why the contractors do not expect to achieve the requirements during the first quarter year of the contract construction phase, then the contractors shall provide a plan calculated to address, to the extent reasonably possibly, these obstacles to a good faith effort to achieve such goals.
- B. Not more than ten days following the end of each work quarter, the contractors will report on the achievement of the goals, detailing the good faith efforts that have been made and will continue to be made and any other appropriate efforts not yet undertaken.
- C. All reports will be signed by an officer or principal of the company who has the authority to contractually obligate the company.

**Section 3. Recruitment and Training**

Any board, officer, committee, or other agency of the Town, which acts on behalf of the Town in making or supervising any contract, in an amount exceeding the sum of \$100,000 for the purchase of goods or services or for the construction, renovation, or repair of buildings or other improvement of real estate, may make arrangements with contractors and other interested agencies for special programs of recruitment and training in connection with the work to be performed on such contract, with the objective of promoting equal employment opportunity for members of minority groups protected by the fair employment laws of the Commonwealth and the United States. Any board, officer, committee or other Town agency may expend Town funds in carrying them out provided that appropriations specifically designed for such purposes have been voted by the Town Meeting.



## TOWN OF ARLINGTON EQUAL OPPORTUNITY ADVISORY COMMITTEE

730 MASSACHUSETTS AVENUE, ARLINGTON, MA 02476  
PHONE (781) 316-3120 FAX: (781) 316-3129

TRICIA O'DONOGHUE, CHAIR  
BARBARA BOLTZ  
AUGUSTA HAYDOCK  
JACK JONES

CARYN COVE MALLOY  
EQUAL OPPORTUNITY OFFICER

### CONTRACTOR CERTIFICATION

During the performance of the Contract, the Contractor and all subcontractors (hereafter collectively referred to as "the Contractor") for a town construction contract or town assisted construction contract, for him/herself, his/her assignees and successors in interest, agree to comply with all applicable equal employment opportunity, non-discrimination and affirmative action requirements, including but not limited to the following:

The Contractor shall comply with the provisions of Town of Arlington Bylaws, Anti-Discrimination policies and Chapter 151B of the Massachusetts General Laws, as amended, and all other applicable anti-discrimination and equal opportunity laws, all of which are herein incorporated by reference and made a part of this contract.

In connection with the performance of work under this contract, the Contractor shall undertake, in good faith, affirmative action measures to eliminate any discriminatory barrier in the terms and conditions of employment on the grounds of race, color, religious creed, national origin, sex, gender identity, sexual orientation, age, genetic information, ancestry, children, marital status, veteran status or membership in the armed service, the receiving of public assistance, and handicap. Such affirmative action measures shall entail a list of positive and aggressive measures which shall include but not be limited to, advertising employment opportunities in minority and other community news media; notifying minority women and other community-based organizations of employment opportunities; maintaining a file of names and addresses of each worker referred to the Contractor and what action was taken concerning such worker; and notifying this Committee in writing when a union with whom the Contractor has a collective bargaining agreement has failed to refer a minority or woman worker.

The Contractor shall submit to the Equal Opportunity Advisory Committee, through the Purchasing Director Domenic Lanzillotti, the following Contractor's Certification with all attachments. The Contractor's Certification will be reviewed by the Committee and will inform the Contractor of any deficiencies to be corrected.

## CONTRACTOR CERTIFICATION

\_\_\_\_\_ certifies that they:

(Contractor Name)

1. Will not discriminate in their employment practices.
2. Intend to use, if General Contractor, the following listed construction trades in the work under the contract:

---

---

---

3. If Trade Subcontractor, will provide the following work under the contract:

---

---

---

4. Will make good faith efforts to comply with the minority employee and women employee workforce participation ratio goals of the Town of Arlington and the Commonwealth of Massachusetts and specific affirmative steps contained herein; and to provide evidence of its good faith efforts. Attached hereto, please find:

- A. Employment Opportunities advertised in:

---

---

---

- B. Notification to Minority/Women/Community based Organizations such as:

---

---

---

C. List of workers referred to Contractor and note on what action was taken:

---

---

---

D. Written notification that Union/Local No. \_\_\_\_\_ failed to refer a Minority or  
Female worker during the week of: \_\_\_\_\_

---

Signature of Officer

Date

---

Printed Name of Officer and Title

"General Decision Number: MA20220021 08/05/2022

Superseded General Decision Number: MA20210021

State: Massachusetts

Construction Type: Highway

County: Middlesex County in Massachusetts.

HIGHWAY CONSTRUCTION PROJECTS

Note: Contracts subject to the Davis-Bacon Act are generally required to pay at least the applicable minimum wage rate required under Executive Order 14026 or Executive Order 13658. Please note that these Executive Orders apply to covered contracts entered into by the federal government that are subject to the Davis-Bacon Act itself, but do not apply to contracts subject only to the Davis-Bacon Related Acts, including those set forth at 29 CFR 5.1(a)(2)-(60).

<p>If the contract is entered into on or after January 30, 2022, or the contract is renewed or extended (e.g., an option is exercised) on or after January 30, 2022:</p>	<ul style="list-style-type: none"> <li>. Executive Order 14026 generally applies to the contract.</li> <li>. The contractor must pay all covered workers at least \$15.00 per hour (or the applicable wage rate listed on this wage determination, if it is higher) for all hours spent performing on the contract in 2022.</li> </ul>
<p>If the contract was awarded on or between January 1, 2015 and January 29, 2022, and the contract is not renewed or extended on or after January 30, 2022:</p>	<ul style="list-style-type: none"> <li>. Executive Order 13658 generally applies to the contract.</li> <li>. The contractor must pay all covered workers at least \$11.25 per hour (or the applicable wage rate listed on this wage determination, if it is higher) for all hours spent performing on that contract in 2022.</li> </ul>

The applicable Executive Order minimum wage rate will be adjusted annually. If this contract is covered by one of the Executive Orders and a classification considered necessary for performance of work on the contract does not appear on this wage determination, the contractor must still submit a conformance request.

Additional information on contractor requirements and worker protections under the Executive Orders is available at <https://www.dol.gov/agencies/whd/government-contracts>.

Modification Number	Publication Date
0	01/07/2022
1	02/25/2022
2	04/22/2022

\* ELEC0103-007 03/01/2022

	Rates	Fringes
ELECTRICIAN.....	\$ 57.32	34.68
-----		
ENGI0004-026 12/01/2021		

	Rates	Fringes
POWER EQUIPMENT OPERATOR		
Group 1.....	\$ 48.73	29.25+A
GROUP 1.....	\$ 51.38	31.10
Group 2.....	\$ 48.23	29.25+A
GROUP 2.....	\$ 50.83	31.10

FOOTNOTE FOR POWER EQUIPMENT OPERATORS:  
 A. PAID HOLIDAYS: New Year's Day, Washington's Birthday,  
 Labor Day, Memorial Day, Independence Day, Patriot's Day,  
 Columbus Day, Veteran's Day, Thanksgiving Day, Christmas Day

POWER EQUIPMENT OPERATORS CLASSIFICATIONS  
 Group 1: Backhoe/Excavator/Trackhoe; Bobcat/Skid Steer/Skid  
 Loader; Broom/Sweeper; Gradall; Loader; Paver (Asphalt,  
 Aggregate, and Concrete)  
 Group 2: Bulldozer; Grader/Blade; Milling Machine; Roller

	Rates	Fringes
-----		
IRON0007-031 03/16/2022		
IRONWORKER (ORNAMENTAL, REINFORCING, AND STRUCTURAL).....	\$ 50.60	39.20
-----		

	Rates	Fringes
LABORER		
Asphalt, Includes Raker, Shoveler, Spreader and Distributor.....	\$ 33.50	22.92
Landscape.....	\$ 33.25	22.92
-----		

	Rates	Fringes
PAIN0035-023 07/01/2019		
PAINTER (Steel).....	\$ 50.66	30.90
-----		

	Rates	Fringes
SUMA2014-011 01/11/2017		
CARPENTER, Includes Form Work....	\$ 47.93	19.46
CEMENT MASON/CONCRETE FINISHER...	\$ 56.70	21.08
LABORER: Common or General.....	\$ 36.58	19.40
LABORER: Concrete Saw (Hand Held/Walk Behind).....	\$ 41.78	18.37

LABORER: Guardrail Installation.....	\$ 37.70	15.37
OPERATOR: Crane.....	\$ 57.61	0.00
OPERATOR: Forklift.....	\$ 64.67	0.00
OPERATOR: Mechanic.....	\$ 48.14	17.02
OPERATOR: Piledriver.....	\$ 44.46	16.94
OPERATOR: Post Driver (Guardrail/Fences).....	\$ 41.49	23.07
PAINTER: Spray (Linestriping)....	\$ 40.87	13.86
PILEDRIVERMAN.....	\$ 45.65	23.33
TRAFFIC CONTROL: Flagger.....	\$ 23.00	20.44
TRAFFIC CONTROL: Laborer-Cones/ Barricades/Barrels - Setter/Mover/Sweeper.....	\$ 44.49	12.41
TRUCK DRIVER: Concrete Truck....	\$ 33.69	15.79
TRUCK DRIVER: Dump Truck.....	\$ 38.92	9.73
TRUCK DRIVER: Flatbed Truck.....	\$ 48.53	0.00

-----  
WELDERS - Receive rate prescribed for craft performing operation to which welding is incidental.

=====  
Note: Executive Order (EO) 13706, Establishing Paid Sick Leave for Federal Contractors applies to all contracts subject to the Davis-Bacon Act for which the contract is awarded (and any solicitation was issued) on or after January 1, 2017. If this contract is covered by the EO, the contractor must provide employees with 1 hour of paid sick leave for every 30 hours they work, up to 56 hours of paid sick leave each year. Employees must be permitted to use paid sick leave for their own illness, injury or other health-related needs, including preventive care; to assist a family member (or person who is like family to the employee) who is ill, injured, or has other health-related needs, including preventive care; or for reasons resulting from, or to assist a family member (or person who is like family to the employee) who is a victim of, domestic violence, sexual assault, or stalking. Additional information on contractor requirements and worker protections under the EO is available at <https://www.dol.gov/agencies/whd/government-contracts>.

Unlisted classifications needed for work not included within the scope of the classifications listed may be added after award only as provided in the labor standards contract clauses (29CFR 5.5 (a) (1) (ii)).

-----



The body of each wage determination lists the classification and wage rates that have been found to be prevailing for the cited type(s) of construction in the area covered by the wage determination. The classifications are listed in alphabetical order of ""identifiers"" that indicate whether the particular rate is a union rate (current union negotiated rate for local), a survey rate (weighted average rate) or a union average rate (weighted union average rate).

#### Union Rate Identifiers

A four letter classification abbreviation identifier enclosed in dotted lines beginning with characters other than ""SU"" or ""UAVG"" denotes that the union classification and rate were prevailing for that classification in the survey. Example: PLUM0198-005 07/01/2014. PLUM is an abbreviation identifier of the union which prevailed in the survey for this classification, which in this example would be Plumbers. 0198 indicates the local union number or district council number where applicable, i.e., Plumbers Local 0198. The next number, 005 in the example, is an internal number used in processing the wage determination. 07/01/2014 is the effective date of the most current negotiated rate, which in this example is July 1, 2014.

Union prevailing wage rates are updated to reflect all rate changes in the collective bargaining agreement (CBA) governing this classification and rate.

#### Survey Rate Identifiers

Classifications listed under the ""SU"" identifier indicate that no one rate prevailed for this classification in the survey and the published rate is derived by computing a weighted average rate based on all the rates reported in the survey for that classification. As this weighted average rate includes all rates reported in the survey, it may include both union and non-union rates. Example: SULA2012-007 5/13/2014. SU indicates the rates are survey rates based on a weighted average calculation of rates and are not majority rates. LA indicates the State of Louisiana. 2012 is the year of survey on which these classifications and rates are based. The next number, 007 in the example, is an internal number used in producing the wage determination. 5/13/2014 indicates the survey completion date for the classifications and rates under that identifier.

Survey wage rates are not updated and remain in effect until a new survey is conducted.

#### Union Average Rate Identifiers

Classification(s) listed under the UAVG identifier indicate that no single majority rate prevailed for those classifications; however, 100% of the data reported for the classifications was union data. EXAMPLE: UAVG-OH-0010 08/29/2014. UAVG indicates that the rate is a weighted union average rate. OH indicates the state. The next number, 0010 in the example, is an internal number used in producing the wage determination. 08/29/2014 indicates the survey completion date for the classifications and rates under that identifier.

A UAVG rate will be updated once a year, usually in January of each year, to reflect a weighted average of the current negotiated/CBA rate of the union locals from which the rate is

based.

-----  
WAGE DETERMINATION APPEALS PROCESS

1.) Has there been an initial decision in the matter? This can be:

- \* an existing published wage determination
- \* a survey underlying a wage determination
- \* a Wage and Hour Division letter setting forth a position on a wage determination matter
- \* a conformance (additional classification and rate) ruling

On survey related matters, initial contact, including requests for summaries of surveys, should be with the Wage and Hour National Office because National Office has responsibility for the Davis-Bacon survey program. If the response from this initial contact is not satisfactory, then the process described in 2.) and 3.) should be followed.

With regard to any other matter not yet ripe for the formal process described here, initial contact should be with the Branch of Construction Wage Determinations. Write to:

Branch of Construction Wage Determinations  
Wage and Hour Division  
U.S. Department of Labor  
200 Constitution Avenue, N.W.  
Washington, DC 20210

2.) If the answer to the question in 1.) is yes, then an interested party (those affected by the action) can request review and reconsideration from the Wage and Hour Administrator (See 29 CFR Part 1.8 and 29 CFR Part 7). Write to:

Wage and Hour Administrator  
U.S. Department of Labor  
200 Constitution Avenue, N.W.  
Washington, DC 20210

The request should be accompanied by a full statement of the interested party's position and by any information (wage payment data, project description, area practice material, etc.) that the requestor considers relevant to the issue.

3.) If the decision of the Administrator is not favorable, an interested party may appeal directly to the Administrative Review Board (formerly the Wage Appeals Board). Write to:

Administrative Review Board  
U.S. Department of Labor  
200 Constitution Avenue, N.W.  
Washington, DC 20210

4.) All decisions by the Administrative Review Board are final.

=====  
END OF GENERAL DECISIO"





**THE COMMONWEALTH OF MASSACHUSETTS  
EXECUTIVE OFFICE OF LABOR AND WORKFORCE DEVELOPMENT  
DEPARTMENT OF LABOR STANDARDS**

**Prevailing Wage Rates**

**As determined by the Director under the provisions of the  
Massachusetts General Laws, Chapter 149, Sections 26 to 27H**

CHARLES D. BAKER  
Governor

ROSALIN ACOSTA  
Secretary

KARYN E. POLITO  
Lt. Governor

MICHAEL FLANAGAN  
Director

**Awarding Authority:** Town of Arlington  
**Contract Number:** 22-39 **City/Town:** ARLINGTON  
**Description of Work:** Lead Water Service Replacement Project/Various Locations as required  
**Job Location:** Various Locations

**Information about Prevailing Wage Schedules for Awarding Authorities and Contractors**

- **The wage rates will remain in effect for the duration of the project, except in the case of multi-year public construction projects. For construction projects lasting longer than one year, awarding authorities must request an updated wage schedule no later than two weeks before the anniversary of the date the contract was executed by the awarding authority and the general contractor.** For multi-year CM AT RISK projects, the awarding authority must request an annual update no later than two weeks before the anniversary date, determined as the earlier of: (a) the execution date of the GMP Amendment, or (b) the execution date of the first amendment to permit procurement of construction services. The annual update requirement is not applicable to 27F "rental of equipment" contracts. **The updated wage schedule must be provided to all contractors, including general and sub-contractors, working on the construction project.**
- This wage schedule applies only to the specific project referenced at the top of this page and uniquely identified by the "Wage Request Number" on all pages of this schedule.
- An Awarding Authority must request an updated wage schedule if it has not opened bids or selected a contractor within 90 days of the date of issuance of the wage schedule. For CM AT RISK projects (bid pursuant to G.L. c.149A), the earlier of: (a) the execution date of the GMP Amendment, or (b) the bid for the first construction scope of work must be within 90-days of the wage schedule issuance date.
- The wage schedule shall be incorporated in any advertisement or call for bids for the project as required by M.G.L. c. 149, § 27. The wage schedule shall be made a part of the contract awarded for the project. The wage schedule must be posted in a conspicuous place at the work site for the life of the project in accordance with M.G.L. c. 149 § 27. The wages listed on the wage schedule must be paid to employees performing construction work on the project whether they are employed by the prime contractor, a filed sub-bidder, or a sub-contractor.
- Apprentices working on the project are required to be registered with the Massachusetts Division of Apprentice Standards (DAS). Apprentices must keep their apprentice identification card on their persons during all work hours on the project. An apprentice registered with DAS may be paid the lower apprentice wage rate at the applicable step as provided on the prevailing wage schedule. **Any apprentice not registered with DAS regardless of whether they are registered with another federal, state, local, or private agency must be paid the journeyworker's rate.**
- Every contractor or subcontractor working on the construction project must submit weekly payroll reports and a Statement of Compliance directly to the awarding authority by mail or email and keep them on file for three years. Each weekly payroll report must contain: the employee's name, address, occupational classification, hours worked, and wages paid. Do not submit weekly payroll reports to DLS. For a sample payroll reporting form go to <http://www.mass.gov/dols/pw>.
- Contractors with questions about the wage rates or classifications included on the wage schedule have an affirmative obligation to inquire with DLS at (617) 626-6953.
- Contractors must obtain the wage schedules from awarding authorities. Failure of a contractor or subcontractor to pay the prevailing wage rates listed on the wage schedule to all employees who perform construction work on the project is a violation of the law and subjects the contractor or subcontractor to civil and criminal penalties.
- Employees not receiving the prevailing wage rate set forth on the wage schedule may file a complaint with the Fair Labor Division of the office of the Attorney General at (617) 727-3465.

Classification	Effective Date	Base Wage	Health	Pension	Supplemental Unemployment	Total Rate
<b>Construction</b>						
(2 AXLE) DRIVER - EQUIPMENT <i>TEAMSTERS JOINT COUNCIL NO. 10 ZONE A</i>	12/01/2021	\$37.05	\$13.41	\$16.01	\$0.00	\$66.47
(3 AXLE) DRIVER - EQUIPMENT <i>TEAMSTERS JOINT COUNCIL NO. 10 ZONE A</i>	12/01/2021	\$37.12	\$13.41	\$16.01	\$0.00	\$66.54
(4 & 5 AXLE) DRIVER - EQUIPMENT <i>TEAMSTERS JOINT COUNCIL NO. 10 ZONE A</i>	12/01/2021	\$37.24	\$13.41	\$16.01	\$0.00	\$66.66
ADS/SUBMERSIBLE PILOT <i>PILE DRIVER LOCAL 56 (ZONE 1)</i>	08/01/2020	\$103.05	\$9.40	\$23.12	\$0.00	\$135.57
For apprentice rates see "Apprentice- PILE DRIVER"						
AIR TRACK OPERATOR <i>LABORERS - ZONE 1</i>	06/01/2022	\$42.93	\$9.10	\$17.57	\$0.00	\$69.60
	12/01/2022	\$43.93	\$9.10	\$17.57	\$0.00	\$70.60
	06/01/2023	\$44.93	\$9.10	\$17.57	\$0.00	\$71.60
	12/01/2023	\$46.18	\$9.10	\$17.57	\$0.00	\$72.85
For apprentice rates see "Apprentice- LABORER"						
AIR TRACK OPERATOR (HEAVY & HIGHWAY) <i>LABORERS - ZONE 1 (HEAVY &amp; HIGHWAY)</i>	12/01/2021	\$41.93	\$9.10	\$17.57	\$0.00	\$68.60
For apprentice rates see "Apprentice- LABORER (Heavy and Highway)"						
ASBESTOS REMOVER - PIPE / MECH. EQUIPT. <i>HEAT &amp; FROST INSULATORS LOCAL 6 (BOSTON)</i>	12/01/2020	\$38.10	\$12.80	\$9.45	\$0.00	\$60.35
ASPHALT RAKER <i>LABORERS - ZONE 1</i>	06/01/2022	\$42.43	\$9.10	\$17.57	\$0.00	\$69.10
	12/01/2022	\$43.43	\$9.10	\$17.57	\$0.00	\$70.10
	06/01/2023	\$44.43	\$9.10	\$17.57	\$0.00	\$71.10
	12/01/2023	\$45.68	\$9.10	\$17.57	\$0.00	\$72.35
For apprentice rates see "Apprentice- LABORER"						
ASPHALT RAKER (HEAVY & HIGHWAY) <i>LABORERS - ZONE 1 (HEAVY &amp; HIGHWAY)</i>	12/01/2021	\$41.43	\$9.10	\$17.57	\$0.00	\$68.10
For apprentice rates see "Apprentice- LABORER (Heavy and Highway)"						
ASPHALT/CONCRETE/CRUSHER PLANT-ON SITE <i>OPERATING ENGINEERS LOCAL 4</i>	12/01/2021	\$51.38	\$14.00	\$16.05	\$0.00	\$81.43
For apprentice rates see "Apprentice- OPERATING ENGINEERS"						
BACKHOE/FRONT-END LOADER <i>OPERATING ENGINEERS LOCAL 4</i>	12/01/2021	\$51.38	\$14.00	\$16.05	\$0.00	\$81.43
For apprentice rates see "Apprentice- OPERATING ENGINEERS"						
BARCO-TYPE JUMPING TAMPER <i>LABORERS - ZONE 1</i>	06/01/2022	\$42.43	\$9.10	\$17.57	\$0.00	\$69.10
	12/01/2022	\$43.43	\$9.10	\$17.57	\$0.00	\$70.10
	06/01/2023	\$44.43	\$9.10	\$17.57	\$0.00	\$71.10
	12/01/2023	\$45.68	\$9.10	\$17.57	\$0.00	\$72.35
For apprentice rates see "Apprentice- LABORER"						
BLOCK PAVER, RAMMER / CURB SETTER <i>LABORERS - ZONE 1</i>	06/01/2022	\$42.93	\$9.10	\$17.57	\$0.00	\$69.60
	12/01/2022	\$43.93	\$9.10	\$17.57	\$0.00	\$70.60
	06/01/2023	\$44.93	\$9.10	\$17.57	\$0.00	\$71.60
	12/01/2023	\$46.18	\$9.10	\$17.57	\$0.00	\$72.85
For apprentice rates see "Apprentice- LABORER"						
BLOCK PAVER, RAMMER / CURB SETTER (HEAVY & HIGHWAY) <i>LABORERS - ZONE 1 (HEAVY &amp; HIGHWAY)</i>	12/01/2021	\$41.93	\$9.10	\$17.57	\$0.00	\$68.60
For apprentice rates see "Apprentice- LABORER (Heavy and Highway)"						
BOILER MAKER <i>BOILERMAKERS LOCAL 29</i>	01/01/2020	\$46.10	\$7.07	\$17.98	\$0.00	\$71.15

**Apprentice - BOILERMAKER - Local 29**

**Effective Date - 01/01/2020**

Step	percent	Apprentice Base Wage	Health	Pension	Supplemental Unemployment	Total Rate
1	65	\$29.97	\$7.07	\$11.69	\$0.00	\$48.73
2	65	\$29.97	\$7.07	\$11.69	\$0.00	\$48.73
3	70	\$32.27	\$7.07	\$12.59	\$0.00	\$51.93
4	75	\$34.58	\$7.07	\$13.49	\$0.00	\$55.14
5	80	\$36.88	\$7.07	\$14.38	\$0.00	\$58.33
6	85	\$39.19	\$7.07	\$15.29	\$0.00	\$61.55
7	90	\$41.49	\$7.07	\$16.18	\$0.00	\$64.74
8	95	\$43.80	\$7.07	\$17.09	\$0.00	\$67.96

Notes:

**Apprentice to Journeyworker Ratio:1:4**

BRICK/STONE/ARTIFICIAL MASONRY (INCL. MASONRY WATERPROOFING) BRICKLAYERS LOCAL 3 (BOSTON)	02/01/2022	\$57.15	\$11.39	\$22.34	\$0.00	\$90.88
--	------------	---------	---------	---------	--------	---------

**Apprentice - BRICK/PLASTER/CEMENT MASON - Local 3 Boston**

**Effective Date - 02/01/2022**

Step	percent	Apprentice Base Wage	Health	Pension	Supplemental Unemployment	Total Rate
1	50	\$28.58	\$11.39	\$22.34	\$0.00	\$62.31
2	60	\$34.29	\$11.39	\$22.34	\$0.00	\$68.02
3	70	\$40.01	\$11.39	\$22.34	\$0.00	\$73.74
4	80	\$45.72	\$11.39	\$22.34	\$0.00	\$79.45
5	90	\$51.44	\$11.39	\$22.34	\$0.00	\$85.17

Notes:

**Apprentice to Journeyworker Ratio:1:5**

BULLDOZER/GRADER/SCRAPER OPERATING ENGINEERS LOCAL 4	12/01/2021	\$50.83	\$14.00	\$16.05	\$0.00	\$80.88
---	------------	---------	---------	---------	--------	---------

For apprentice rates see "Apprentice- OPERATING ENGINEERS"

CAISSON & UNDERPINNING BOTTOM MAN LABORERS - FOUNDATION AND MARINE	12/01/2021	\$42.33	\$9.10	\$17.72	\$0.00	\$69.15
---	------------	---------	--------	---------	--------	---------

For apprentice rates see "Apprentice- LABORER"

CAISSON & UNDERPINNING LABORER LABORERS - FOUNDATION AND MARINE	12/01/2021	\$41.18	\$9.10	\$17.72	\$0.00	\$68.00
--	------------	---------	--------	---------	--------	---------

For apprentice rates see "Apprentice- LABORER"

CAISSON & UNDERPINNING TOP MAN LABORERS - FOUNDATION AND MARINE	12/01/2021	\$41.18	\$9.10	\$17.72	\$0.00	\$68.00
--	------------	---------	--------	---------	--------	---------

For apprentice rates see "Apprentice- LABORER"

Classification	Effective Date	Base Wage	Health	Pension	Supplemental Unemployment	Total Rate
CARBIDE CORE DRILL OPERATOR <i>LABORERS - ZONE 1</i>	06/01/2022	\$42.43	\$9.10	\$17.57	\$0.00	\$69.10
	12/01/2022	\$43.43	\$9.10	\$17.57	\$0.00	\$70.10
	06/01/2023	\$44.43	\$9.10	\$17.57	\$0.00	\$71.10
	12/01/2023	\$45.68	\$9.10	\$17.57	\$0.00	\$72.35

For apprentice rates see "Apprentice- LABORER"

CARPENTER <i>CARPENTERS -ZONE 2 (Eastern Massachusetts)</i>	03/01/2022	\$44.53	\$8.68	\$19.97	\$0.00	\$73.18
	09/01/2022	\$45.18	\$8.68	\$19.97	\$0.00	\$73.83
	03/01/2023	\$45.78	\$8.68	\$19.97	\$0.00	\$74.43

**Apprentice - CARPENTER - Zone 2 Eastern MA**

**Effective Date - 03/01/2022**

Step	percent	Apprentice Base Wage	Health	Pension	Supplemental Unemployment	Total Rate
1	50	\$22.27	\$8.68	\$1.73	\$0.00	\$32.68
2	60	\$26.72	\$8.68	\$1.73	\$0.00	\$37.13
3	70	\$31.17	\$8.68	\$14.78	\$0.00	\$54.63
4	75	\$33.40	\$8.68	\$14.78	\$0.00	\$56.86
5	80	\$35.62	\$8.68	\$16.51	\$0.00	\$60.81
6	80	\$35.62	\$8.68	\$16.51	\$0.00	\$60.81
7	90	\$40.08	\$8.68	\$18.24	\$0.00	\$67.00
8	90	\$40.08	\$8.68	\$18.24	\$0.00	\$67.00

**Effective Date - 09/01/2022**

Step	percent	Apprentice Base Wage	Health	Pension	Supplemental Unemployment	Total Rate
1	50	\$22.59	\$8.68	\$1.73	\$0.00	\$33.00
2	60	\$27.11	\$8.68	\$1.73	\$0.00	\$37.52
3	70	\$31.63	\$8.68	\$14.78	\$0.00	\$55.09
4	75	\$33.89	\$8.68	\$14.78	\$0.00	\$57.35
5	80	\$36.14	\$8.68	\$16.51	\$0.00	\$61.33
6	80	\$36.14	\$8.68	\$16.51	\$0.00	\$61.33
7	90	\$40.66	\$8.68	\$18.24	\$0.00	\$67.58
8	90	\$40.66	\$8.68	\$18.24	\$0.00	\$67.58

**Notes:**

% Indentured After 10/1/17; 45/45/55/55/70/70/80/80  
Step 1&2 \$30.45/ 3&4 \$36.57/ 5&6 \$56.36/ 7&8 \$62.54

**Apprentice to Journeyworker Ratio:1:5**

CARPENTER WOOD FRAME <i>CARPENTERS-ZONE 3 (Wood Frame)</i>	04/01/2022	\$23.66	\$7.21	\$4.80	\$0.00	\$35.67
	04/01/2023	\$24.16	\$7.21	\$4.80	\$0.00	\$36.17

All Aspects of New Wood Frame Work

**Classification**

**Effective Date    Base Wage    Health    Pension    Supplemental Unemployment    Total Rate**

**Apprentice - CARPENTER (Wood Frame) - Zone 3**

**Effective Date - 04/01/2022**

Step	percent	Apprentice Base Wage	Health	Pension	Supplemental Unemployment	Total Rate
1	60	\$14.20	\$7.21	\$0.00	\$0.00	\$21.41
2	60	\$14.20	\$7.21	\$0.00	\$0.00	\$21.41
3	65	\$15.38	\$7.21	\$0.00	\$0.00	\$22.59
4	70	\$16.56	\$7.21	\$0.00	\$0.00	\$23.77
5	75	\$17.75	\$7.21	\$3.80	\$0.00	\$28.76
6	80	\$18.93	\$7.21	\$3.80	\$0.00	\$29.94
7	85	\$20.11	\$7.21	\$3.80	\$0.00	\$31.12
8	90	\$21.29	\$7.21	\$3.80	\$0.00	\$32.30

**Effective Date - 04/01/2023**

Step	percent	Apprentice Base Wage	Health	Pension	Supplemental Unemployment	Total Rate
1	60	\$14.50	\$7.21	\$0.00	\$0.00	\$21.71
2	60	\$14.50	\$7.21	\$0.00	\$0.00	\$21.71
3	65	\$15.70	\$7.21	\$0.00	\$0.00	\$22.91
4	70	\$16.91	\$7.21	\$0.00	\$0.00	\$24.12
5	75	\$18.12	\$7.21	\$3.80	\$0.00	\$29.13
6	80	\$19.33	\$7.21	\$3.80	\$0.00	\$30.34
7	85	\$20.54	\$7.21	\$3.80	\$0.00	\$31.55
8	90	\$21.74	\$7.21	\$3.80	\$0.00	\$32.75

**Notes:**

% Indentured After 10/1/17; 45/45/55/55/70/70/80/80  
 Step 1&2 \$17.86/ 3&4 \$20.22/ 5&6 \$27.57/ 7&8 \$29.94

**Apprentice to Journeyworker Ratio:1:5**

CEMENT MASONRY/PLASTERING BRICKLAYERS LOCAL 3 (BOSTON)	01/01/2020	\$49.07	\$12.75	\$22.41	\$0.62	\$84.85
---	------------	---------	---------	---------	--------	---------

**Apprentice - CEMENT MASONRY/PLASTERING - Eastern Mass (Boston)**

**Effective Date - 01/01/2020**

Step	percent	Apprentice Base Wage	Health	Pension	Supplemental Unemployment	Total Rate
1	50	\$24.54	\$12.75	\$15.41	\$0.00	\$52.70
2	60	\$29.44	\$12.75	\$17.41	\$0.62	\$60.22
3	65	\$31.90	\$12.75	\$18.41	\$0.62	\$63.68
4	70	\$34.35	\$12.75	\$19.41	\$0.62	\$67.13
5	75	\$36.80	\$12.75	\$20.41	\$0.62	\$70.58
6	80	\$39.26	\$12.75	\$21.41	\$0.62	\$74.04
7	90	\$44.16	\$12.75	\$22.41	\$0.62	\$79.94

**Notes:**

Steps 3,4 are 500 hrs. All other steps are 1,000 hrs.

**Apprentice to Journeyworker Ratio:1:3**



Classification	Effective Date	Base Wage	Health	Pension	Supplemental Unemployment	Total Rate
CHAIN SAW OPERATOR <i>LABORERS - ZONE 1</i>	06/01/2022	\$42.43	\$9.10	\$17.57	\$0.00	\$69.10
	12/01/2022	\$43.43	\$9.10	\$17.57	\$0.00	\$70.10
	06/01/2023	\$44.43	\$9.10	\$17.57	\$0.00	\$71.10
	12/01/2023	\$45.68	\$9.10	\$17.57	\$0.00	\$72.35
For apprentice rates see "Apprentice- LABORER"						
CLAM SHELLS/SLURRY BUCKETS/HEADING MACHINES <i>OPERATING ENGINEERS LOCAL 4</i>	12/01/2021	\$52.38	\$14.00	\$16.05	\$0.00	\$82.43
For apprentice rates see "Apprentice- OPERATING ENGINEERS"						
COMPRESSOR OPERATOR <i>OPERATING ENGINEERS LOCAL 4</i>	12/01/2021	\$33.69	\$14.00	\$16.05	\$0.00	\$63.74
For apprentice rates see "Apprentice- OPERATING ENGINEERS"						
DELEADER (BRIDGE) <i>PAINTERS LOCAL 35 - ZONE 2</i>	07/01/2022	\$54.86	\$8.65	\$23.05	\$0.00	\$86.56
	01/01/2023	\$56.06	\$8.65	\$23.05	\$0.00	\$87.76
	07/01/2023	\$57.26	\$8.65	\$23.05	\$0.00	\$88.96
	01/01/2024	\$58.46	\$8.65	\$23.05	\$0.00	\$90.16
	07/01/2024	\$59.66	\$8.65	\$23.05	\$0.00	\$91.36
	01/01/2025	\$60.86	\$8.65	\$23.05	\$0.00	\$92.56

**Apprentice - PAINTER Local 35 - BRIDGES/TANKS**

**Effective Date - 07/01/2022**

Step	percent	Apprentice Base Wage	Health	Pension	Supplemental Unemployment	Total Rate
1	50	\$27.43	\$8.65	\$0.00	\$0.00	\$36.08
2	55	\$30.17	\$8.65	\$6.27	\$0.00	\$45.09
3	60	\$32.92	\$8.65	\$6.84	\$0.00	\$48.41
4	65	\$35.66	\$8.65	\$7.41	\$0.00	\$51.72
5	70	\$38.40	\$8.65	\$19.63	\$0.00	\$66.68
6	75	\$41.15	\$8.65	\$20.20	\$0.00	\$70.00
7	80	\$43.89	\$8.65	\$20.77	\$0.00	\$73.31
8	90	\$49.37	\$8.65	\$21.91	\$0.00	\$79.93

**Effective Date - 01/01/2023**

Step	percent	Apprentice Base Wage	Health	Pension	Supplemental Unemployment	Total Rate
1	50	\$28.03	\$8.65	\$0.00	\$0.00	\$36.68
2	55	\$30.83	\$8.65	\$6.27	\$0.00	\$45.75
3	60	\$33.64	\$8.65	\$6.84	\$0.00	\$49.13
4	65	\$36.44	\$8.65	\$7.41	\$0.00	\$52.50
5	70	\$39.24	\$8.65	\$19.63	\$0.00	\$67.52
6	75	\$42.05	\$8.65	\$20.20	\$0.00	\$70.90
7	80	\$44.85	\$8.65	\$20.77	\$0.00	\$74.27
8	90	\$50.45	\$8.65	\$21.91	\$0.00	\$81.01

**Notes:**

Steps are 750 hrs.

**Apprentice to Journeyworker Ratio:1:1**

<b>Classification</b>	<b>Effective Date</b>	<b>Base Wage</b>	<b>Health</b>	<b>Pension</b>	<b>Supplemental Unemployment</b>	<b>Total Rate</b>
DEMO: ADZEMAN <i>LABORERS - ZONE 1</i>	06/01/2022	\$42.33	\$9.10	\$17.57	\$0.00	\$69.00
	12/01/2022	\$43.33	\$9.10	\$17.57	\$0.00	\$70.00
	06/01/2023	\$44.33	\$9.10	\$17.57	\$0.00	\$71.00
	12/01/2023	\$45.58	\$9.10	\$17.57	\$0.00	\$72.25
For apprentice rates see "Apprentice- LABORER"						
DEMO: BACKHOE/LOADER/HAMMER OPERATOR <i>LABORERS - ZONE 1</i>	06/01/2022	\$43.33	\$9.10	\$17.57	\$0.00	\$70.00
	12/01/2022	\$44.33	\$9.10	\$17.57	\$0.00	\$71.00
	06/01/2023	\$45.33	\$9.10	\$17.57	\$0.00	\$72.00
	12/01/2023	\$46.58	\$9.10	\$17.57	\$0.00	\$73.25
For apprentice rates see "Apprentice- LABORER"						
DEMO: BURNERS <i>LABORERS - ZONE 1</i>	06/01/2022	\$43.08	\$9.10	\$17.57	\$0.00	\$69.75
	12/01/2022	\$44.08	\$9.10	\$17.57	\$0.00	\$70.75
	06/01/2023	\$45.08	\$9.10	\$17.57	\$0.00	\$71.75
	12/01/2023	\$46.33	\$9.10	\$17.57	\$0.00	\$73.00
For apprentice rates see "Apprentice- LABORER"						
DEMO: CONCRETE CUTTER/SAWYER <i>LABORERS - ZONE 1</i>	06/01/2022	\$43.33	\$9.10	\$17.57	\$0.00	\$70.00
	12/01/2022	\$44.33	\$9.10	\$17.57	\$0.00	\$71.00
	06/01/2023	\$45.33	\$9.10	\$17.57	\$0.00	\$72.00
	12/01/2023	\$46.58	\$9.10	\$17.57	\$0.00	\$73.25
For apprentice rates see "Apprentice- LABORER"						
DEMO: JACKHAMMER OPERATOR <i>LABORERS - ZONE 1</i>	06/01/2022	\$43.08	\$9.10	\$17.57	\$0.00	\$69.75
	12/01/2022	\$44.08	\$9.10	\$17.57	\$0.00	\$70.75
	06/01/2023	\$45.08	\$9.10	\$17.57	\$0.00	\$71.75
	12/01/2023	\$46.33	\$9.10	\$17.57	\$0.00	\$73.00
For apprentice rates see "Apprentice- LABORER"						
DEMO: WRECKING LABORER <i>LABORERS - ZONE 1</i>	06/01/2022	\$42.33	\$9.10	\$17.57	\$0.00	\$69.00
	12/01/2022	\$43.33	\$9.10	\$17.57	\$0.00	\$70.00
	06/01/2023	\$44.33	\$9.10	\$17.57	\$0.00	\$71.00
	12/01/2023	\$45.58	\$9.10	\$17.57	\$0.00	\$72.25
For apprentice rates see "Apprentice- LABORER"						
DIRECTIONAL DRILL MACHINE OPERATOR <i>OPERATING ENGINEERS LOCAL 4</i>	12/01/2021	\$50.83	\$14.00	\$16.05	\$0.00	\$80.88
For apprentice rates see "Apprentice- OPERATING ENGINEERS"						
DIVER <i>PILE DRIVER LOCAL 56 (ZONE 1)</i>	08/01/2020	\$68.70	\$9.40	\$23.12	\$0.00	\$101.22
For apprentice rates see "Apprentice- PILE DRIVER"						
DIVER TENDER <i>PILE DRIVER LOCAL 56 (ZONE 1)</i>	08/01/2020	\$49.07	\$9.40	\$23.12	\$0.00	\$81.59
For apprentice rates see "Apprentice- PILE DRIVER"						
DIVER TENDER (EFFLUENT) <i>PILE DRIVER LOCAL 56 (ZONE 1)</i>	08/01/2020	\$73.60	\$9.40	\$23.12	\$0.00	\$106.12
For apprentice rates see "Apprentice- PILE DRIVER"						
DIVER/SLURRY (EFFLUENT) <i>PILE DRIVER LOCAL 56 (ZONE 1)</i>	08/01/2020	\$103.05	\$9.40	\$23.12	\$0.00	\$135.57
For apprentice rates see "Apprentice- PILE DRIVER"						
DRAWBRIDGE OPERATOR (Construction) <i>DRAWBRIDGE - SEIU LOCAL 888</i>	07/01/2020	\$26.77	\$6.67	\$3.93	\$0.16	\$37.53

Classification	Effective Date	Base Wage	Health	Pension	Supplemental Unemployment	Total Rate
ELECTRICIAN ELECTRICIANS LOCAL 103	03/01/2022	\$57.32	\$13.00	\$20.82	\$0.00	\$91.14
	09/01/2022	\$58.76	\$13.00	\$20.86	\$0.00	\$92.62
	03/01/2023	\$60.43	\$13.00	\$20.91	\$0.00	\$94.34

**Apprentice - ELECTRICIAN - Local 103**

**Effective Date - 03/01/2022**

Step	percent	Apprentice Base Wage	Health	Pension	Supplemental Unemployment	Total Rate
1	40	\$22.93	\$13.00	\$0.69	\$0.00	\$36.62
2	40	\$22.93	\$13.00	\$0.69	\$0.00	\$36.62
3	45	\$25.79	\$13.00	\$15.62	\$0.00	\$54.41
4	45	\$25.79	\$13.00	\$15.62	\$0.00	\$54.41
5	50	\$28.66	\$13.00	\$16.10	\$0.00	\$57.76
6	55	\$31.53	\$13.00	\$16.58	\$0.00	\$61.11
7	60	\$34.39	\$13.00	\$17.04	\$0.00	\$64.43
8	65	\$37.26	\$13.00	\$17.52	\$0.00	\$67.78
9	70	\$40.12	\$13.00	\$17.98	\$0.00	\$71.10
10	75	\$42.99	\$13.00	\$18.46	\$0.00	\$74.45

**Effective Date - 09/01/2022**

Step	percent	Apprentice Base Wage	Health	Pension	Supplemental Unemployment	Total Rate
1	40	\$23.50	\$13.00	\$0.71	\$0.00	\$37.21
2	40	\$23.50	\$13.00	\$0.71	\$0.00	\$37.21
3	45	\$26.44	\$13.00	\$15.64	\$0.00	\$55.08
4	45	\$26.44	\$13.00	\$15.64	\$0.00	\$55.08
5	50	\$29.38	\$13.00	\$16.12	\$0.00	\$58.50
6	55	\$32.32	\$13.00	\$16.60	\$0.00	\$61.92
7	60	\$35.26	\$13.00	\$17.07	\$0.00	\$65.33
8	65	\$38.19	\$13.00	\$17.55	\$0.00	\$68.74
9	70	\$41.13	\$13.00	\$18.01	\$0.00	\$72.14
10	75	\$44.07	\$13.00	\$18.49	\$0.00	\$75.56

**Notes :**  
App Prior 1/1/03; 30/35/40/45/50/55/65/70/75/80

**Apprentice to Journeyworker Ratio:2:3\*\*\***

ELEVATOR CONSTRUCTOR ELEVATOR CONSTRUCTORS LOCAL 4	01/01/2022	\$65.62	\$16.03	\$20.21	\$0.00	\$101.86
---	------------	---------	---------	---------	--------	----------

**Apprentice - ELEVATOR CONSTRUCTOR - Local 4**

**Effective Date - 01/01/2022**

Step	percent	Apprentice Base Wage	Health	Pension	Supplemental Unemployment	Total Rate
1	50	\$32.81	\$16.03	\$0.00	\$0.00	\$48.84
2	55	\$36.09	\$16.03	\$20.21	\$0.00	\$72.33
3	65	\$42.65	\$16.03	\$20.21	\$0.00	\$78.89
4	70	\$45.93	\$16.03	\$20.21	\$0.00	\$82.17
5	80	\$52.50	\$16.03	\$20.21	\$0.00	\$88.74

**Notes:**

Steps 1-2 are 6 mos.; Steps 3-5 are 1 year

**Apprentice to Journeyworker Ratio:1:1**

ELEVATOR CONSTRUCTOR HELPER <i>ELEVATOR CONSTRUCTORS LOCAL 4</i>	01/01/2022	\$45.93	\$16.03	\$20.21	\$0.00	\$82.17
---	------------	---------	---------	---------	--------	---------

For apprentice rates see "Apprentice - ELEVATOR CONSTRUCTOR"

FENCE & GUARD RAIL ERECTOR (HEAVY & HIGHWAY) <i>LABORERS - ZONE 1 (HEAVY &amp; HIGHWAY)</i>	12/01/2021	\$41.43	\$9.10	\$17.57	\$0.00	\$68.10
--	------------	---------	--------	---------	--------	---------

For apprentice rates see "Apprentice- LABORER (Heavy and Highway)"

FIELD ENG.INST.PERSON-BLDG,SITE,HVY/HWY <i>OPERATING ENGINEERS LOCAL 4</i>	05/01/2022	\$47.18	\$14.00	\$16.05	\$0.00	\$77.23
---	------------	---------	---------	---------	--------	---------

For apprentice rates see "Apprentice- OPERATING ENGINEERS"

FIELD ENG.PARTY CHIEF-BLDG,SITE,HVY/HWY <i>OPERATING ENGINEERS LOCAL 4</i>	05/01/2022	\$48.72	\$14.00	\$16.05	\$0.00	\$78.77
---	------------	---------	---------	---------	--------	---------

For apprentice rates see "Apprentice- OPERATING ENGINEERS"

FIELD ENG.ROD PERSON-BLDG,SITE,HVY/HWY <i>OPERATING ENGINEERS LOCAL 4</i>	05/01/2022	\$23.33	\$14.00	\$16.05	\$0.00	\$53.38
--	------------	---------	---------	---------	--------	---------

For apprentice rates see "Apprentice- OPERATING ENGINEERS"

FIRE ALARM INSTALLER <i>ELECTRICIANS LOCAL 103</i>	03/01/2022	\$57.32	\$13.00	\$20.82	\$0.00	\$91.14
	09/01/2022	\$58.76	\$13.00	\$20.86	\$0.00	\$92.62
	03/01/2023	\$60.43	\$13.00	\$20.91	\$0.00	\$94.34

For apprentice rates see "Apprentice- ELECTRICIAN"

FIRE ALARM REPAIR / MAINTENANCE <i>LOCAL 103</i> / COMMISSIONING <i>ELECTRICIANS</i>	03/01/2022	\$44.71	\$13.00	\$18.74	\$0.00	\$76.45
	09/01/2022	\$46.42	\$13.00	\$18.87	\$0.00	\$78.29
	03/01/2023	\$48.34	\$13.00	\$19.01	\$0.00	\$80.35

For apprentice rates see "Apprentice- TELECOMMUNICATIONS TECHNICIAN"

FIREMAN (ASST. ENGINEER) <i>OPERATING ENGINEERS LOCAL 4</i>	12/01/2021	\$41.76	\$14.00	\$16.05	\$0.00	\$71.81
--	------------	---------	---------	---------	--------	---------

For apprentice rates see "Apprentice- OPERATING ENGINEERS"

FLAGGER & SIGNALER (HEAVY & HIGHWAY) <i>LABORERS - ZONE 1 (HEAVY &amp; HIGHWAY)</i>	12/01/2021	\$24.50	\$9.10	\$17.57	\$0.00	\$51.17
--	------------	---------	--------	---------	--------	---------

For apprentice rates see "Apprentice- LABORER (Heavy and Highway)"

FLOORCOVERER <i>FLOORCOVERERS LOCAL 2168 ZONE 1</i>	03/01/2022	\$49.93	\$8.68	\$20.27	\$0.00	\$78.88
--	------------	---------	--------	---------	--------	---------

**Classification**

**Effective Date    Base Wage    Health    Pension    Supplemental Unemployment    Total Rate**

**Apprentice - FLOORCOVERER - Local 2168 Zone I**

**Effective Date - 03/01/2022**

Step	percent	Apprentice Base Wage	Health	Pension	Supplemental Unemployment	Total Rate
1	50	\$24.97	\$8.68	\$1.79	\$0.00	\$35.44
2	55	\$27.46	\$8.68	\$1.79	\$0.00	\$37.93
3	60	\$29.96	\$8.68	\$14.90	\$0.00	\$53.54
4	65	\$32.45	\$8.68	\$14.90	\$0.00	\$56.03
5	70	\$34.95	\$8.68	\$16.69	\$0.00	\$60.32
6	75	\$37.45	\$8.68	\$16.69	\$0.00	\$62.82
7	80	\$39.94	\$8.68	\$18.48	\$0.00	\$67.10
8	85	\$42.44	\$8.68	\$18.48	\$0.00	\$69.60

**Notes:** Steps are 750 hrs.  
 % After 10/1/17; 45/45/55/55/70/70/80/80 (1500hr Steps)  
 Step 1&2 \$32.94/ 3&4 \$39.66/ 5&6 \$60.32/ 7&8 \$67.10

**Apprentice to Journeyworker Ratio:1:1**

FORK LIFT/CHERRY PICKER <i>OPERATING ENGINEERS LOCAL 4</i>	12/01/2021	\$51.38	\$14.00	\$16.05	\$0.00	\$81.43
For apprentice rates see "Apprentice- OPERATING ENGINEERS"						
GENERATOR/LIGHTING PLANT/HEATERS <i>OPERATING ENGINEERS LOCAL 4</i>	12/01/2021	\$33.69	\$14.00	\$16.05	\$0.00	\$63.74
For apprentice rates see "Apprentice- OPERATING ENGINEERS"						
GLAZIER (GLASS PLANK/AIR BARRIER/INTERIOR SYSTEMS) <i>GLAZIERS LOCAL 35 (ZONE 2)</i>	07/01/2022	\$44.36	\$8.65	\$23.05	\$0.00	\$76.06
	01/01/2023	\$45.56	\$8.65	\$23.05	\$0.00	\$77.26
	07/01/2023	\$46.76	\$8.65	\$23.05	\$0.00	\$78.46
	01/01/2024	\$47.96	\$8.65	\$23.05	\$0.00	\$79.66
	07/01/2024	\$49.16	\$8.65	\$23.05	\$0.00	\$80.86
	01/01/2025	\$50.36	\$8.65	\$23.05	\$0.00	\$82.06

**Classification**

**Effective Date    Base Wage    Health    Pension    Supplemental Unemployment    Total Rate**

**Apprentice - GLAZIER - Local 35 Zone 2**

**Effective Date - 07/01/2022**

Step	percent	Apprentice Base Wage	Health	Pension	Supplemental Unemployment	Total Rate
1	50	\$22.18	\$8.65	\$0.00	\$0.00	\$30.83
2	55	\$24.40	\$8.65	\$6.27	\$0.00	\$39.32
3	60	\$26.62	\$8.65	\$6.84	\$0.00	\$42.11
4	65	\$28.83	\$8.65	\$7.41	\$0.00	\$44.89
5	70	\$31.05	\$8.65	\$19.63	\$0.00	\$59.33
6	75	\$33.27	\$8.65	\$20.20	\$0.00	\$62.12
7	80	\$35.49	\$8.65	\$20.77	\$0.00	\$64.91
8	90	\$39.92	\$8.65	\$21.91	\$0.00	\$70.48

**Effective Date - 01/01/2023**

Step	percent	Apprentice Base Wage	Health	Pension	Supplemental Unemployment	Total Rate
1	50	\$22.78	\$8.65	\$0.00	\$0.00	\$31.43
2	55	\$25.06	\$8.65	\$6.27	\$0.00	\$39.98
3	60	\$27.34	\$8.65	\$6.84	\$0.00	\$42.83
4	65	\$29.61	\$8.65	\$7.41	\$0.00	\$45.67
5	70	\$31.89	\$8.65	\$19.63	\$0.00	\$60.17
6	75	\$34.17	\$8.65	\$20.20	\$0.00	\$63.02
7	80	\$36.45	\$8.65	\$20.77	\$0.00	\$65.87
8	90	\$41.00	\$8.65	\$21.91	\$0.00	\$71.56

**Notes:**  
Steps are 750 hrs.

**Apprentice to Journeyworker Ratio:1:1**

HOISTING ENGINEER/CRANES/GRADALLS OPERATING ENGINEERS LOCAL 4	12/01/2021	\$51.38	\$14.00	\$16.05	\$0.00	\$81.43
--	------------	---------	---------	---------	--------	---------

**Apprentice - OPERATING ENGINEERS - Local 4**

**Effective Date - 12/01/2021**

Step	percent	Apprentice Base Wage	Health	Pension	Supplemental Unemployment	Total Rate
1	55	\$28.26	\$14.00	\$0.00	\$0.00	\$42.26
2	60	\$30.83	\$14.00	\$16.05	\$0.00	\$60.88
3	65	\$33.40	\$14.00	\$16.05	\$0.00	\$63.45
4	70	\$35.97	\$14.00	\$16.05	\$0.00	\$66.02
5	75	\$38.54	\$14.00	\$16.05	\$0.00	\$68.59
6	80	\$41.10	\$14.00	\$16.05	\$0.00	\$71.15
7	85	\$43.67	\$14.00	\$16.05	\$0.00	\$73.72
8	90	\$46.24	\$14.00	\$16.05	\$0.00	\$76.29

**Notes:**

**Apprentice to Journeyworker Ratio:1:6**

HVAC (DUCTWORK) SHEETMETAL WORKERS LOCAL 17 - A	02/01/2022	\$53.70	\$13.80	\$25.60	\$2.79	\$95.89
--	------------	---------	---------	---------	--------	---------

For apprentice rates see "Apprentice- SHEET METAL WORKER"

HVAC (ELECTRICAL CONTROLS) ELECTRICIANS LOCAL 103	03/01/2022	\$57.32	\$13.00	\$20.82	\$0.00	\$91.14
	09/01/2022	\$58.76	\$13.00	\$20.86	\$0.00	\$92.62
	03/01/2023	\$60.43	\$13.00	\$20.91	\$0.00	\$94.34

For apprentice rates see "Apprentice- ELECTRICIAN"

HVAC (TESTING AND BALANCING - AIR) SHEETMETAL WORKERS LOCAL 17 - A	02/01/2022	\$53.70	\$13.80	\$25.60	\$2.79	\$95.89
---	------------	---------	---------	---------	--------	---------

For apprentice rates see "Apprentice- SHEET METAL WORKER"

HVAC (TESTING AND BALANCING -WATER) PIPEFITTERS LOCAL 537	03/01/2021	\$57.94	\$11.70	\$20.24	\$0.00	\$89.88
--	------------	---------	---------	---------	--------	---------

For apprentice rates see "Apprentice- PIPEFITTER" or "PLUMBER/PIPEFITTER"

HVAC MECHANIC PIPEFITTERS LOCAL 537	03/01/2021	\$57.94	\$11.70	\$20.24	\$0.00	\$89.88
--	------------	---------	---------	---------	--------	---------

For apprentice rates see "Apprentice- PIPEFITTER" or "PLUMBER/PIPEFITTER"

HYDRAULIC DRILLS LABORERS - ZONE 1	06/01/2022	\$42.93	\$9.10	\$17.57	\$0.00	\$69.60
	12/01/2022	\$43.93	\$9.10	\$17.57	\$0.00	\$70.60
	06/01/2023	\$44.93	\$9.10	\$17.57	\$0.00	\$71.60
	12/01/2023	\$46.18	\$9.10	\$17.57	\$0.00	\$72.85

For apprentice rates see "Apprentice- LABORER"

HYDRAULIC DRILLS (HEAVY & HIGHWAY) LABORERS - ZONE 1 (HEAVY & HIGHWAY)	12/01/2021	\$41.93	\$9.10	\$17.57	\$0.00	\$68.60
---	------------	---------	--------	---------	--------	---------

For apprentice rates see "Apprentice- LABORER (Heavy and Highway)"

INSULATOR (PIPES & TANKS) HEAT & FROST INSULATORS LOCAL 6 (BOSTON)	09/01/2021	\$51.40	\$13.80	\$17.14	\$0.00	\$82.34
	09/01/2022	\$53.85	\$13.80	\$17.14	\$0.00	\$84.79

**Classification**

**Effective Date   Base Wage   Health   Pension   Supplemental Unemployment   Total Rate**

**Apprentice - ASBESTOS INSULATOR (Pipes & Tanks) - Local 6 Boston**

**Effective Date - 09/01/2021**

Step	percent	Apprentice Base Wage	Health	Pension	Supplemental Unemployment	Total Rate
1	50	\$25.70	\$13.80	\$12.42	\$0.00	\$51.92
2	60	\$30.84	\$13.80	\$13.36	\$0.00	\$58.00
3	70	\$35.98	\$13.80	\$14.31	\$0.00	\$64.09
4	80	\$41.12	\$13.80	\$15.25	\$0.00	\$70.17

**Effective Date - 09/01/2022**

Step	percent	Apprentice Base Wage	Health	Pension	Supplemental Unemployment	Total Rate
1	50	\$26.93	\$13.80	\$12.42	\$0.00	\$53.15
2	60	\$32.31	\$13.80	\$13.36	\$0.00	\$59.47
3	70	\$37.70	\$13.80	\$14.31	\$0.00	\$65.81
4	80	\$43.08	\$13.80	\$15.25	\$0.00	\$72.13

**Notes:**

Steps are 1 year

**Apprentice to Journeyworker Ratio:1:4**

<b>IRONWORKER/WELDER</b> <i>IRONWORKERS LOCAL 7 (BOSTON AREA)</i>	03/16/2022	\$50.60	\$8.20	\$26.50	\$0.00	\$85.30
--	------------	---------	--------	---------	--------	---------

**Apprentice - IRONWORKER - Local 7 Boston**

**Effective Date - 03/16/2022**

Step	percent	Apprentice Base Wage	Health	Pension	Supplemental Unemployment	Total Rate
1	60	\$30.36	\$8.20	\$26.50	\$0.00	\$65.06
2	70	\$35.42	\$8.20	\$26.50	\$0.00	\$70.12
3	75	\$37.95	\$8.20	\$26.50	\$0.00	\$72.65
4	80	\$40.48	\$8.20	\$26.50	\$0.00	\$75.18
5	85	\$43.01	\$8.20	\$26.50	\$0.00	\$77.71
6	90	\$45.54	\$8.20	\$26.50	\$0.00	\$80.24

**Notes:**

\*\* Structural 1:6; Ornamental 1:4

**Apprentice to Journeyworker Ratio:\*\***

<b>JACKHAMMER &amp; PAVING BREAKER OPERATOR</b> <i>LABORERS - ZONE 1</i>	06/01/2022	\$42.43	\$9.10	\$17.57	\$0.00	\$69.10
	12/01/2022	\$43.43	\$9.10	\$17.57	\$0.00	\$70.10
	06/01/2023	\$44.43	\$9.10	\$17.57	\$0.00	\$71.10
	12/01/2023	\$45.68	\$9.10	\$17.57	\$0.00	\$72.35

For apprentice rates see "Apprentice- LABORER"

<b>LABORER</b> <i>LABORERS - ZONE 1</i>	06/01/2022	\$42.18	\$9.10	\$17.57	\$0.00	\$68.85
	12/01/2022	\$43.18	\$9.10	\$17.57	\$0.00	\$69.85
	06/01/2023	\$44.18	\$9.10	\$17.57	\$0.00	\$70.85
	12/01/2023	\$45.43	\$9.10	\$17.57	\$0.00	\$72.10



**Classification**

**Effective Date    Base Wage    Health    Pension    Supplemental Unemployment    Total Rate**

**Apprentice - LABORER - Zone 1**

**Effective Date - 06/01/2022**

Step	percent	Apprentice Base Wage	Health	Pension	Supplemental Unemployment	Total Rate
1	60	\$25.31	\$9.10	\$17.57	\$0.00	\$51.98
2	70	\$29.53	\$9.10	\$17.57	\$0.00	\$56.20
3	80	\$33.74	\$9.10	\$17.57	\$0.00	\$60.41
4	90	\$37.96	\$9.10	\$17.57	\$0.00	\$64.63

**Effective Date - 12/01/2022**

Step	percent	Apprentice Base Wage	Health	Pension	Supplemental Unemployment	Total Rate
1	60	\$25.91	\$9.10	\$17.57	\$0.00	\$52.58
2	70	\$30.23	\$9.10	\$17.57	\$0.00	\$56.90
3	80	\$34.54	\$9.10	\$17.57	\$0.00	\$61.21
4	90	\$38.86	\$9.10	\$17.57	\$0.00	\$65.53

**Notes:**

**Apprentice to Journeyworker Ratio:1:5**

LABORER (HEAVY & HIGHWAY) LABORERS - ZONE 1 (HEAVY & HIGHWAY)	12/01/2021	\$41.18	\$9.10	\$17.57	\$0.00	\$67.85
--	------------	---------	--------	---------	--------	---------

**Apprentice - LABORER (Heavy & Highway) - Zone 1**

**Effective Date - 12/01/2021**

Step	percent	Apprentice Base Wage	Health	Pension	Supplemental Unemployment	Total Rate
1	60	\$24.71	\$9.10	\$17.57	\$0.00	\$51.38
2	70	\$28.83	\$9.10	\$17.57	\$0.00	\$55.50
3	80	\$32.94	\$9.10	\$17.57	\$0.00	\$59.61
4	90	\$37.06	\$9.10	\$17.57	\$0.00	\$63.73

**Notes:**

**Apprentice to Journeyworker Ratio:1:5**

LABORER: CARPENTER TENDER LABORERS - ZONE 1	06/01/2022	\$42.18	\$9.10	\$17.57	\$0.00	\$68.85
	12/01/2022	\$43.18	\$9.10	\$17.57	\$0.00	\$69.85
	06/01/2023	\$44.18	\$9.10	\$17.57	\$0.00	\$70.85
	12/01/2023	\$45.43	\$9.10	\$17.57	\$0.00	\$72.10

For apprentice rates see "Apprentice- LABORER"

LABORER: CEMENT FINISHER TENDER LABORERS - ZONE 1	06/01/2022	\$42.18	\$9.10	\$17.57	\$0.00	\$68.85
	12/01/2022	\$43.18	\$9.10	\$17.57	\$0.00	\$69.85
	06/01/2023	\$44.18	\$9.10	\$17.57	\$0.00	\$70.85
	12/01/2023	\$45.43	\$9.10	\$17.57	\$0.00	\$72.10

For apprentice rates see "Apprentice- LABORER"

Classification	Effective Date	Base Wage	Health	Pension	Supplemental Unemployment	Total Rate
LABORER: HAZARDOUS WASTE/ASBESTOS REMOVER <i>LABORERS - ZONE 1</i>	06/01/2022	\$42.33	\$9.10	\$17.57	\$0.00	\$69.00
	12/01/2022	\$43.33	\$9.10	\$17.57	\$0.00	\$70.00
	06/01/2023	\$44.33	\$9.10	\$17.57	\$0.00	\$71.00
	12/01/2023	\$45.58	\$9.10	\$17.57	\$0.00	\$72.25
For apprentice rates see "Apprentice- LABORER"						
LABORER: MASON TENDER <i>LABORERS - ZONE 1</i>	06/01/2022	\$42.43	\$9.10	\$17.57	\$0.00	\$69.10
	12/01/2022	\$43.43	\$9.10	\$17.57	\$0.00	\$70.10
	06/01/2023	\$44.43	\$9.10	\$17.57	\$0.00	\$71.10
	06/01/2024	\$45.68	\$9.10	\$17.57	\$0.00	\$72.35
For apprentice rates see "Apprentice- LABORER"						
LABORER: MASON TENDER (HEAVY & HIGHWAY) <i>LABORERS - ZONE 1 (HEAVY &amp; HIGHWAY)</i>	12/01/2021	\$41.43	\$9.10	\$17.57	\$0.00	\$68.10
For apprentice rates see "Apprentice- LABORER (Heavy and Highway)"						
LABORER: MULTI-TRADE TENDER <i>LABORERS - ZONE 1</i>	06/01/2022	\$42.18	\$9.10	\$17.57	\$0.00	\$68.85
	12/01/2022	\$43.18	\$9.10	\$17.57	\$0.00	\$69.85
	06/01/2023	\$44.18	\$9.10	\$17.57	\$0.00	\$70.85
	12/01/2023	\$45.43	\$9.10	\$17.57	\$0.00	\$72.10
For apprentice rates see "Apprentice- LABORER"						
LABORER: TREE REMOVER <i>LABORERS - ZONE 1</i>	06/01/2022	\$42.18	\$9.10	\$17.57	\$0.00	\$68.85
	12/01/2022	\$43.18	\$9.10	\$17.57	\$0.00	\$69.85
	06/01/2023	\$44.18	\$9.10	\$17.57	\$0.00	\$70.85
	12/01/2023	\$45.43	\$9.10	\$17.57	\$0.00	\$72.10
This classification applies to the removal of standing trees, and the trimming and removal of branches and limbs when related to public works construction or site clearance incidental to construction . For apprentice rates see "Apprentice- LABORER"						
LASER BEAM OPERATOR <i>LABORERS - ZONE 1</i>	06/01/2022	\$42.43	\$9.10	\$17.57	\$0.00	\$69.10
	12/01/2022	\$43.43	\$9.10	\$17.57	\$0.00	\$70.10
	06/01/2023	\$44.43	\$9.10	\$17.57	\$0.00	\$71.10
	12/01/2023	\$45.68	\$9.10	\$17.57	\$0.00	\$72.35
For apprentice rates see "Apprentice- LABORER"						
LASER BEAM OPERATOR (HEAVY & HIGHWAY) <i>LABORERS - ZONE 1 (HEAVY &amp; HIGHWAY)</i>	12/01/2021	\$41.43	\$9.10	\$17.57	\$0.00	\$68.10
For apprentice rates see "Apprentice- LABORER (Heavy and Highway)"						
MARBLE & TILE FINISHERS <i>BRICKLAYERS LOCAL 3 - MARBLE &amp; TILE</i>	02/01/2022	\$43.69	\$11.39	\$20.37	\$0.00	\$75.45

**Apprentice - MARBLE & TILE FINISHER - Local 3 Marble & Tile**

**Effective Date - 02/01/2022**

Step	percent	Apprentice Base Wage	Health	Pension	Supplemental Unemployment	Total Rate
1	50	\$21.85	\$11.39	\$20.37	\$0.00	\$53.61
2	60	\$26.21	\$11.39	\$20.37	\$0.00	\$57.97
3	70	\$30.58	\$11.39	\$20.37	\$0.00	\$62.34
4	80	\$34.95	\$11.39	\$20.37	\$0.00	\$66.71
5	90	\$39.32	\$11.39	\$20.37	\$0.00	\$71.08

**Notes:**

**Apprentice to Journeyworker Ratio:1:3**

Classification	Effective Date	Base Wage	Health	Pension	Supplemental Unemployment	Total Rate
MARBLE MASONS, TILELAYERS & TERRAZZO MECH <i>BRICKLAYERS LOCAL 3 - MARBLE &amp; TILE</i>	02/01/2022	\$57.17	\$11.39	\$22.31	\$0.00	\$90.87

**Apprentice - MARBLE-TILE-TERRAZZO MECHANIC - Local 3 Marble & Tile**

**Effective Date - 02/01/2022**

Step	percent	Apprentice Base Wage	Health	Pension	Supplemental Unemployment	Total Rate
1	50	\$28.59	\$11.39	\$22.31	\$0.00	\$62.29
2	60	\$34.30	\$11.39	\$22.31	\$0.00	\$68.00
3	70	\$40.02	\$11.39	\$22.31	\$0.00	\$73.72
4	80	\$45.74	\$11.39	\$22.31	\$0.00	\$79.44
5	90	\$51.45	\$11.39	\$22.31	\$0.00	\$85.15

**Notes:**

**Apprentice to Journeyworker Ratio:1:5**

MECH. SWEEPER OPERATOR (ON CONST. SITES) <i>OPERATING ENGINEERS LOCAL 4</i>	12/01/2021	\$50.83	\$14.00	\$16.05	\$0.00	\$80.88
--	------------	---------	---------	---------	--------	---------

For apprentice rates see "Apprentice- OPERATING ENGINEERS"

MECHANICS MAINTENANCE <i>OPERATING ENGINEERS LOCAL 4</i>	12/01/2021	\$50.83	\$14.00	\$16.05	\$0.00	\$80.88
---	------------	---------	---------	---------	--------	---------

For apprentice rates see "Apprentice- OPERATING ENGINEERS"

MILLWRIGHT (Zone 1) <i>MILLWRIGHTS LOCAL 1121 - Zone 1</i>	01/03/2022	\$45.52	\$8.58	\$21.57	\$0.00	\$75.67
	01/02/2023	\$47.27	\$8.58	\$21.57	\$0.00	\$77.42

**Apprentice - MILLWRIGHT - Local 1121 Zone 1**

**Effective Date - 01/03/2022**

Step	percent	Apprentice Base Wage	Health	Pension	Supplemental Unemployment	Total Rate
1	55	\$25.04	\$8.58	\$5.72	\$0.00	\$39.34
2	65	\$29.59	\$8.58	\$17.93	\$0.00	\$56.10
3	75	\$34.14	\$8.58	\$18.98	\$0.00	\$61.70
4	85	\$38.69	\$8.58	\$20.01	\$0.00	\$67.28

**Effective Date - 01/02/2023**

Step	percent	Apprentice Base Wage	Health	Pension	Supplemental Unemployment	Total Rate
1	55	\$26.00	\$8.58	\$5.72	\$0.00	\$40.30
2	65	\$30.73	\$8.58	\$17.93	\$0.00	\$57.24
3	75	\$35.45	\$8.58	\$18.98	\$0.00	\$63.01
4	85	\$40.18	\$8.58	\$20.01	\$0.00	\$68.77

**Notes:** Step 1&2 Appr. indentured after 1/6/2020 receive no pension, but do receive annuity. (Step 1 \$5.72, Step 2 \$6.66)  
Steps are 2,000 hours

**Apprentice to Journeyworker Ratio:1:4**

<b>Classification</b>	<b>Effective Date</b>	<b>Base Wage</b>	<b>Health</b>	<b>Pension</b>	<b>Supplemental Unemployment</b>	<b>Total Rate</b>
MORTAR MIXER <i>LABORERS - ZONE 1</i>	06/01/2022	\$42.43	\$9.10	\$17.57	\$0.00	\$69.10
	12/01/2022	\$43.43	\$9.10	\$17.57	\$0.00	\$70.10
	06/01/2023	\$44.43	\$9.10	\$17.57	\$0.00	\$71.10
	12/01/2023	\$45.68	\$9.10	\$17.57	\$0.00	\$72.35
For apprentice rates see "Apprentice- LABORER"						
OILER (OTHER THAN TRUCK CRANES,GRADALLS) <i>OPERATING ENGINEERS LOCAL 4</i>	12/01/2021	\$23.48	\$14.00	\$16.05	\$0.00	\$53.53
For apprentice rates see "Apprentice- OPERATING ENGINEERS"						
OILER (TRUCK CRANES, GRADALLS) <i>OPERATING ENGINEERS LOCAL 4</i>	12/01/2021	\$28.44	\$14.00	\$16.05	\$0.00	\$58.49
For apprentice rates see "Apprentice- OPERATING ENGINEERS"						
OTHER POWER DRIVEN EQUIPMENT - CLASS II <i>OPERATING ENGINEERS LOCAL 4</i>	12/01/2021	\$50.83	\$14.00	\$16.05	\$0.00	\$80.88
For apprentice rates see "Apprentice- OPERATING ENGINEERS"						
Painter (BRIDGES/TANKS) <i>PAINTERS LOCAL 35 - ZONE 2</i>	07/01/2022	\$54.86	\$8.65	\$23.05	\$0.00	\$86.56
	01/01/2023	\$56.06	\$8.65	\$23.05	\$0.00	\$87.76
	07/01/2023	\$57.26	\$8.65	\$23.05	\$0.00	\$88.96
	01/01/2024	\$58.46	\$8.65	\$23.05	\$0.00	\$90.16
	07/01/2024	\$59.66	\$8.65	\$23.05	\$0.00	\$91.36
	01/01/2025	\$60.86	\$8.65	\$23.05	\$0.00	\$92.56

**Classification**

**Effective Date    Base Wage    Health    Pension    Supplemental Unemployment    Total Rate**

**Apprentice - PAINTER Local 35 - BRIDGES/TANKS**

**Effective Date - 07/01/2022**

Step	percent	Apprentice Base Wage	Health	Pension	Supplemental Unemployment	Total Rate
1	50	\$27.43	\$8.65	\$0.00	\$0.00	\$36.08
2	55	\$30.17	\$8.65	\$6.27	\$0.00	\$45.09
3	60	\$32.92	\$8.65	\$6.84	\$0.00	\$48.41
4	65	\$35.66	\$8.65	\$7.41	\$0.00	\$51.72
5	70	\$38.40	\$8.65	\$19.63	\$0.00	\$66.68
6	75	\$41.15	\$8.65	\$20.20	\$0.00	\$70.00
7	80	\$43.89	\$8.65	\$20.77	\$0.00	\$73.31
8	90	\$49.37	\$8.65	\$21.91	\$0.00	\$79.93

**Effective Date - 01/01/2023**

Step	percent	Apprentice Base Wage	Health	Pension	Supplemental Unemployment	Total Rate
1	50	\$28.03	\$8.65	\$0.00	\$0.00	\$36.68
2	55	\$30.83	\$8.65	\$6.27	\$0.00	\$45.75
3	60	\$33.64	\$8.65	\$6.84	\$0.00	\$49.13
4	65	\$36.44	\$8.65	\$7.41	\$0.00	\$52.50
5	70	\$39.24	\$8.65	\$19.63	\$0.00	\$67.52
6	75	\$42.05	\$8.65	\$20.20	\$0.00	\$70.90
7	80	\$44.85	\$8.65	\$20.77	\$0.00	\$74.27
8	90	\$50.45	\$8.65	\$21.91	\$0.00	\$81.01

**Notes:**

Steps are 750 hrs.

**Apprentice to Journeyworker Ratio:1:1**

PAINTER (SPRAY OR SANDBLAST, NEW) *	07/01/2022	\$45.76	\$8.65	\$23.05	\$0.00	\$77.46
* If 30% or more of surfaces to be painted are new construction, NEW paint rate shall be used. PAINTERS LOCAL 35 - ZONE 2	01/01/2023	\$46.96	\$8.65	\$23.05	\$0.00	\$78.66
	07/01/2023	\$48.16	\$8.65	\$23.05	\$0.00	\$79.86
	01/01/2024	\$49.36	\$8.65	\$23.05	\$0.00	\$81.06
	07/01/2024	\$50.56	\$8.65	\$23.05	\$0.00	\$82.26
	01/01/2025	\$51.76	\$8.65	\$23.05	\$0.00	\$83.46

**Classification**

**Effective Date   Base Wage   Health   Pension   Supplemental Unemployment   Total Rate**

**Apprentice - PAINTER Local 35 Zone 2 - Spray/Sandblast - New**

**Effective Date - 07/01/2022**

Step	percent	Apprentice Base Wage	Health	Pension	Supplemental Unemployment	Total Rate
1	50	\$22.88	\$8.65	\$0.00	\$0.00	\$31.53
2	55	\$25.17	\$8.65	\$6.27	\$0.00	\$40.09
3	60	\$27.46	\$8.65	\$6.84	\$0.00	\$42.95
4	65	\$29.74	\$8.65	\$7.41	\$0.00	\$45.80
5	70	\$32.03	\$8.65	\$19.63	\$0.00	\$60.31
6	75	\$34.32	\$8.65	\$20.20	\$0.00	\$63.17
7	80	\$36.61	\$8.65	\$20.77	\$0.00	\$66.03
8	90	\$41.18	\$8.65	\$21.91	\$0.00	\$71.74

**Effective Date - 01/01/2023**

Step	percent	Apprentice Base Wage	Health	Pension	Supplemental Unemployment	Total Rate
1	50	\$23.48	\$8.65	\$0.00	\$0.00	\$32.13
2	55	\$25.83	\$8.65	\$6.27	\$0.00	\$40.75
3	60	\$28.18	\$8.65	\$6.84	\$0.00	\$43.67
4	65	\$30.52	\$8.65	\$7.41	\$0.00	\$46.58
5	70	\$32.87	\$8.65	\$19.63	\$0.00	\$61.15
6	75	\$35.22	\$8.65	\$20.20	\$0.00	\$64.07
7	80	\$37.57	\$8.65	\$20.77	\$0.00	\$66.99
8	90	\$42.26	\$8.65	\$21.91	\$0.00	\$72.82

**Notes:**

Steps are 750 hrs.

**Apprentice to Journeyworker Ratio:1:1**

PAINTER (SPRAY OR SANDBLAST, REPAINT)	07/01/2022	\$43.82	\$8.65	\$23.05	\$0.00	\$75.52
PAINTERS LOCAL 35 - ZONE 2	01/01/2023	\$45.02	\$8.65	\$23.05	\$0.00	\$76.72
	07/01/2023	\$46.22	\$8.65	\$23.05	\$0.00	\$77.92
	01/01/2024	\$47.42	\$8.65	\$23.05	\$0.00	\$79.12
	07/01/2024	\$48.62	\$8.65	\$23.05	\$0.00	\$80.32
	01/01/2025	\$49.82	\$8.65	\$23.05	\$0.00	\$81.52

**Classification**

**Effective Date    Base Wage    Health    Pension    Supplemental Unemployment    Total Rate**

**Apprentice - PAINTER Local 35 Zone 2 - Spray/Sandblast - Repaint**

**Effective Date - 07/01/2022**

Step	percent	Apprentice Base Wage	Health	Pension	Supplemental Unemployment	Total Rate
1	50	\$21.91	\$8.65	\$0.00	\$0.00	\$30.56
2	55	\$24.10	\$8.65	\$6.27	\$0.00	\$39.02
3	60	\$26.29	\$8.65	\$6.84	\$0.00	\$41.78
4	65	\$28.48	\$8.65	\$7.41	\$0.00	\$44.54
5	70	\$30.67	\$8.65	\$19.63	\$0.00	\$58.95
6	75	\$32.87	\$8.65	\$20.20	\$0.00	\$61.72
7	80	\$35.06	\$8.65	\$20.77	\$0.00	\$64.48
8	90	\$39.44	\$8.65	\$21.91	\$0.00	\$70.00

**Effective Date - 01/01/2023**

Step	percent	Apprentice Base Wage	Health	Pension	Supplemental Unemployment	Total Rate
1	50	\$22.51	\$8.65	\$0.00	\$0.00	\$31.16
2	55	\$24.76	\$8.65	\$6.27	\$0.00	\$39.68
3	60	\$27.01	\$8.65	\$6.84	\$0.00	\$42.50
4	65	\$29.26	\$8.65	\$7.41	\$0.00	\$45.32
5	70	\$31.51	\$8.65	\$19.63	\$0.00	\$59.79
6	75	\$33.77	\$8.65	\$20.20	\$0.00	\$62.62
7	80	\$36.02	\$8.65	\$20.77	\$0.00	\$65.44
8	90	\$40.52	\$8.65	\$21.91	\$0.00	\$71.08

**Notes:**

Steps are 750 hrs.

**Apprentice to Journeyworker Ratio:1:1**

PAINTER / TAPER (BRUSH, NEW) *	07/01/2022	\$44.36	\$8.65	\$23.05	\$0.00	\$76.06
* If 30% or more of surfaces to be painted are new construction, NEW paint rate shall be used. PAINTERS LOCAL 35 - ZONE 2	01/01/2023	\$45.56	\$8.65	\$23.05	\$0.00	\$77.26
	07/01/2023	\$46.76	\$8.65	\$23.05	\$0.00	\$78.46
	01/01/2024	\$47.96	\$8.65	\$23.05	\$0.00	\$79.66
	07/01/2024	\$49.16	\$8.65	\$23.05	\$0.00	\$80.86
	01/01/2025	\$50.36	\$8.65	\$23.05	\$0.00	\$82.06

**Apprentice - PAINTER - Local 35 Zone 2 - BRUSH NEW**

**Effective Date - 07/01/2022**

Step	percent	Apprentice Base Wage	Health	Pension	Supplemental Unemployment	Total Rate
1	50	\$22.18	\$8.65	\$0.00	\$0.00	\$30.83
2	55	\$24.40	\$8.65	\$6.27	\$0.00	\$39.32
3	60	\$26.62	\$8.65	\$6.84	\$0.00	\$42.11
4	65	\$28.83	\$8.65	\$7.41	\$0.00	\$44.89
5	70	\$31.05	\$8.65	\$19.63	\$0.00	\$59.33
6	75	\$33.27	\$8.65	\$20.20	\$0.00	\$62.12
7	80	\$35.49	\$8.65	\$20.77	\$0.00	\$64.91
8	90	\$39.92	\$8.65	\$21.91	\$0.00	\$70.48

**Effective Date - 01/01/2023**

Step	percent	Apprentice Base Wage	Health	Pension	Supplemental Unemployment	Total Rate
1	50	\$22.78	\$8.65	\$0.00	\$0.00	\$31.43
2	55	\$25.06	\$8.65	\$6.27	\$0.00	\$39.98
3	60	\$27.34	\$8.65	\$6.84	\$0.00	\$42.83
4	65	\$29.61	\$8.65	\$7.41	\$0.00	\$45.67
5	70	\$31.89	\$8.65	\$19.63	\$0.00	\$60.17
6	75	\$34.17	\$8.65	\$20.20	\$0.00	\$63.02
7	80	\$36.45	\$8.65	\$20.77	\$0.00	\$65.87
8	90	\$41.00	\$8.65	\$21.91	\$0.00	\$71.56

**Notes:**

Steps are 750 hrs.

**Apprentice to Journeyworker Ratio:1:1**

PAINTER / TAPER (BRUSH, REPAINT)	07/01/2022	\$42.42	\$8.65	\$23.05	\$0.00	\$74.12
PAINTERS LOCAL 35 - ZONE 2	01/01/2023	\$43.62	\$8.65	\$23.05	\$0.00	\$75.32
	07/01/2023	\$44.82	\$8.65	\$23.05	\$0.00	\$76.52
	01/01/2024	\$46.02	\$8.65	\$23.05	\$0.00	\$77.72
	07/01/2024	\$47.22	\$8.65	\$23.05	\$0.00	\$78.92
	01/01/2025	\$48.42	\$8.65	\$23.05	\$0.00	\$80.12



**Classification**

**Effective Date    Base Wage    Health    Pension    Supplemental Unemployment    Total Rate**

**Apprentice - PAINTER Local 35 Zone 2 - BRUSH REPAINT**

**Effective Date - 07/01/2022**

Step	percent	Apprentice Base Wage	Health	Pension	Supplemental Unemployment	Total Rate
1	50	\$21.21	\$8.65	\$0.00	\$0.00	\$29.86
2	55	\$23.33	\$8.65	\$6.27	\$0.00	\$38.25
3	60	\$25.45	\$8.65	\$6.84	\$0.00	\$40.94
4	65	\$27.57	\$8.65	\$7.41	\$0.00	\$43.63
5	70	\$29.69	\$8.65	\$19.63	\$0.00	\$57.97
6	75	\$31.82	\$8.65	\$20.20	\$0.00	\$60.67
7	80	\$33.94	\$8.65	\$20.77	\$0.00	\$63.36
8	90	\$38.18	\$8.65	\$21.91	\$0.00	\$68.74

**Effective Date - 01/01/2023**

Step	percent	Apprentice Base Wage	Health	Pension	Supplemental Unemployment	Total Rate
1	50	\$21.81	\$8.65	\$0.00	\$0.00	\$30.46
2	55	\$23.99	\$8.65	\$6.27	\$0.00	\$38.91
3	60	\$26.17	\$8.65	\$6.84	\$0.00	\$41.66
4	65	\$28.35	\$8.65	\$7.41	\$0.00	\$44.41
5	70	\$30.53	\$8.65	\$19.63	\$0.00	\$58.81
6	75	\$32.72	\$8.65	\$20.20	\$0.00	\$61.57
7	80	\$34.90	\$8.65	\$20.77	\$0.00	\$64.32
8	90	\$39.26	\$8.65	\$21.91	\$0.00	\$69.82

**Notes:**  
Steps are 750 hrs.

**Apprentice to Journeyworker Ratio:1:1**

PAINTER TRAFFIC MARKINGS (HEAVY/HIGHWAY) 12/01/2021 \$41.18 \$9.10 \$17.57 \$0.00 \$67.85  
 LABORERS - ZONE 1 (HEAVY & HIGHWAY)

For apprentice rates see "Apprentice- LABORER (Heavy and Highway)

PANEL & PICKUP TRUCKS DRIVER 12/01/2021 \$36.88 \$13.41 \$16.01 \$0.00 \$66.30  
 TEAMSTERS JOINT COUNCIL NO. 10 ZONE A

PIER AND DOCK CONSTRUCTOR (UNDERPINNING AND DECK) 08/01/2020 \$49.07 \$9.40 \$23.12 \$0.00 \$81.59

PILE DRIVER LOCAL 56 (ZONE 1)

For apprentice rates see "Apprentice- PILE DRIVER"

PILE DRIVER 08/01/2020 \$49.07 \$9.40 \$23.12 \$0.00 \$81.59  
 PILE DRIVER LOCAL 56 (ZONE 1)

**Classification**

**Effective Date    Base Wage    Health    Pension    Supplemental Unemployment    Total Rate**

**Apprentice - PILE DRIVER - Local 56 Zone 1**

**Effective Date - 08/01/2020**

Step	percent	Apprentice Base Wage	Health	Pension	Supplemental Unemployment	Total Rate
1	50	\$24.54	\$9.40	\$23.12	\$0.00	\$57.06
2	60	\$29.44	\$9.40	\$23.12	\$0.00	\$61.96
3	70	\$34.35	\$9.40	\$23.12	\$0.00	\$66.87
4	75	\$36.80	\$9.40	\$23.12	\$0.00	\$69.32
5	80	\$39.26	\$9.40	\$23.12	\$0.00	\$71.78
6	80	\$39.26	\$9.40	\$23.12	\$0.00	\$71.78
7	90	\$44.16	\$9.40	\$23.12	\$0.00	\$76.68
8	90	\$44.16	\$9.40	\$23.12	\$0.00	\$76.68

**Notes:**

% Indentured After 10/1/17; 45/45/55/55/70/70/80/80  
 Step 1&2 \$34.01/ 3&4 \$41.46/ 5&6 \$62.80/ 7&8 \$69.25

**Apprentice to Journeyworker Ratio:1:5**

PIPEFITTER & STEAMFITTER PIPEFITTERS LOCAL 537	03/01/2021	\$57.94	\$11.70	\$20.24	\$0.00	\$89.88
---	------------	---------	---------	---------	--------	---------

**Apprentice - PIPEFITTER - Local 537**

**Effective Date - 03/01/2021**

Step	percent	Apprentice Base Wage	Health	Pension	Supplemental Unemployment	Total Rate
1	40	\$23.18	\$11.70	\$8.25	\$0.00	\$43.13
2	45	\$26.07	\$11.70	\$20.24	\$0.00	\$58.01
3	60	\$34.76	\$11.70	\$20.24	\$0.00	\$66.70
4	70	\$40.56	\$11.70	\$20.24	\$0.00	\$72.50
5	80	\$46.35	\$11.70	\$20.24	\$0.00	\$78.29

**Notes:**

\*\* 1:3; 3:15; 1:10 thereafter / Steps are 1 yr.  
 Refrig/AC Mechanic \*\*1:1;1:2;2:4;3:6;4:8;5:10;6:12;7:14;8:17;9:20;10:23(Max)

**Apprentice to Journeyworker Ratio:\*\***

PIPELAYER LABORERS - ZONE 1	06/01/2022	\$42.43	\$9.10	\$17.57	\$0.00	\$69.10
	12/01/2022	\$43.43	\$9.10	\$17.57	\$0.00	\$70.10
	06/01/2023	\$44.43	\$9.10	\$17.57	\$0.00	\$71.10
	12/01/2023	\$45.68	\$9.10	\$17.57	\$0.00	\$72.35

For apprentice rates see "Apprentice- LABORER"

PIPELAYER (HEAVY & HIGHWAY) LABORERS - ZONE 1 (HEAVY & HIGHWAY)	12/01/2021	\$41.43	\$9.10	\$17.57	\$0.00	\$68.10
--	------------	---------	--------	---------	--------	---------

For apprentice rates see "Apprentice- LABORER (Heavy and Highway)"

Classification	Effective Date	Base Wage	Health	Pension	Supplemental Unemployment	Total Rate
PLUMBERS & GASFITTERS <i>PLUMBERS &amp; GASFITTERS LOCAL 12</i>	03/01/2022	\$61.79	\$14.07	\$18.36	\$0.00	\$94.22
	09/04/2022	\$63.49	\$14.07	\$18.36	\$0.00	\$95.92
	02/26/2023	\$65.19	\$14.07	\$18.36	\$0.00	\$97.62
	09/03/2023	\$66.94	\$14.07	\$18.36	\$0.00	\$99.37
	03/03/2024	\$68.74	\$14.07	\$18.36	\$0.00	\$101.17
	09/01/2024	\$70.54	\$14.07	\$18.36	\$0.00	\$102.97
	03/02/2025	\$72.34	\$14.07	\$18.36	\$0.00	\$104.77

**Apprentice - PLUMBER/GASFITTER - Local 12**

**Effective Date - 03/01/2022**

Step	percent	Apprentice Base Wage	Health	Pension	Supplemental Unemployment	Total Rate
1	35	\$21.63	\$14.07	\$6.63	\$0.00	\$42.33
2	40	\$24.72	\$14.07	\$7.52	\$0.00	\$46.31
3	55	\$33.98	\$14.07	\$10.24	\$0.00	\$58.29
4	65	\$40.16	\$14.07	\$12.04	\$0.00	\$66.27
5	75	\$46.34	\$14.07	\$13.85	\$0.00	\$74.26

**Effective Date - 09/04/2022**

Step	percent	Apprentice Base Wage	Health	Pension	Supplemental Unemployment	Total Rate
1	35	\$22.22	\$14.07	\$6.63	\$0.00	\$42.92
2	40	\$25.40	\$14.07	\$7.52	\$0.00	\$46.99
3	55	\$34.92	\$14.07	\$10.24	\$0.00	\$59.23
4	65	\$41.27	\$14.07	\$12.04	\$0.00	\$67.38
5	75	\$47.62	\$14.07	\$13.85	\$0.00	\$75.54

**Notes:**

\*\* 1:2; 2:6; 3:10; 4:14; 5:19/Steps are 1 yr  
Step4 with lic\$69.00, Step5 with lic\$76.87

**Apprentice to Journeyworker Ratio:\*\***

PNEUMATIC CONTROLS (TEMP.) <i>PIPEFITTERS LOCAL 537</i>	03/01/2021	\$57.94	\$11.70	\$20.24	\$0.00	\$89.88
--	------------	---------	---------	---------	--------	---------

For apprentice rates see "Apprentice- PIPEFITTER" or "PLUMBER/PIPEFITTER"

PNEUMATIC DRILL/TOOL OPERATOR <i>LABORERS - ZONE 1</i>	06/01/2022	\$42.43	\$9.10	\$17.57	\$0.00	\$69.10
	12/01/2022	\$43.43	\$9.10	\$17.57	\$0.00	\$70.10
	06/01/2023	\$44.43	\$9.10	\$17.57	\$0.00	\$71.10
	12/01/2023	\$45.68	\$9.10	\$17.57	\$0.00	\$72.35

For apprentice rates see "Apprentice- LABORER"

PNEUMATIC DRILL/TOOL OPERATOR (HEAVY & HIGHWAY) <i>LABORERS - ZONE 1 (HEAVY &amp; HIGHWAY)</i>	12/01/2021	\$41.43	\$9.10	\$17.57	\$0.00	\$68.10
---	------------	---------	--------	---------	--------	---------

For apprentice rates see "Apprentice- LABORER (Heavy and Highway)"

POWDERMAN & BLASTER <i>LABORERS - ZONE 1</i>	06/01/2022	\$43.18	\$9.10	\$17.57	\$0.00	\$69.85
	12/01/2022	\$44.18	\$9.10	\$17.57	\$0.00	\$70.85
	06/01/2023	\$45.18	\$9.10	\$17.57	\$0.00	\$71.85
	12/01/2023	\$46.43	\$9.10	\$17.57	\$0.00	\$73.10

For apprentice rates see "Apprentice- LABORER"

POWDERMAN & BLASTER (HEAVY & HIGHWAY) <i>LABORERS - ZONE 1 (HEAVY &amp; HIGHWAY)</i>	12/01/2021	\$42.18	\$9.10	\$17.57	\$0.00	\$68.85
---	------------	---------	--------	---------	--------	---------

Classification	Effective Date	Base Wage	Health	Pension	Supplemental Unemployment	Total Rate
For apprentice rates see "Apprentice- LABORER (Heavy and Highway)						
POWER SHOVEL/DERRICK/TRENCHING MACHINE <i>OPERATING ENGINEERS LOCAL 4</i>	12/01/2021	\$51.38	\$14.00	\$16.05	\$0.00	\$81.43
For apprentice rates see "Apprentice- OPERATING ENGINEERS"						
PUMP OPERATOR (CONCRETE) <i>OPERATING ENGINEERS LOCAL 4</i>	12/01/2021	\$51.38	\$14.00	\$16.05	\$0.00	\$81.43
For apprentice rates see "Apprentice- OPERATING ENGINEERS"						
PUMP OPERATOR (DEWATERING, OTHER) <i>OPERATING ENGINEERS LOCAL 4</i>	12/01/2021	\$33.69	\$14.00	\$16.05	\$0.00	\$63.74
For apprentice rates see "Apprentice- OPERATING ENGINEERS"						
READY MIX CONCRETE DRIVERS after 4/30/12 (Drivers Hired After 4/30/2012) <i>TEAMSTERS 25 (Metro) - Aggregate</i>	08/01/2022	\$30.40	\$11.91	\$15.25	\$0.00	\$57.56
READY-MIX CONCRETE DRIVER <i>TEAMSTERS 25 (Metro) - Aggregate</i>	08/01/2022	\$34.41	\$11.91	\$15.25	\$0.00	\$61.57
RECLAIMERS <i>OPERATING ENGINEERS LOCAL 4</i>	12/01/2021	\$50.83	\$14.00	\$16.05	\$0.00	\$80.88
For apprentice rates see "Apprentice- OPERATING ENGINEERS"						
RIDE-ON MOTORIZED BUGGY OPERATOR <i>LABORERS - ZONE 1</i>	06/01/2022	\$42.43	\$9.10	\$17.57	\$0.00	\$69.10
	12/01/2022	\$43.43	\$9.10	\$17.57	\$0.00	\$70.10
	06/01/2023	\$44.43	\$9.10	\$17.57	\$0.00	\$71.10
	12/01/2023	\$45.68	\$9.10	\$17.57	\$0.00	\$72.35
For apprentice rates see "Apprentice- LABORER"						
ROLLER/SPREADER/MULCHING MACHINE <i>OPERATING ENGINEERS LOCAL 4</i>	12/01/2021	\$50.83	\$14.00	\$16.05	\$0.00	\$80.88
For apprentice rates see "Apprentice- OPERATING ENGINEERS"						
ROOFER (Inc.Roofing Waterproofing &Roofing Damproofing) <i>ROOFERS LOCAL 33</i>	02/01/2022	\$47.03	\$12.28	\$19.45	\$0.00	\$78.76

**Apprentice - ROOFER - Local 33**

**Effective Date - 02/01/2022**

Step	percent	Apprentice Base Wage	Health	Pension	Supplemental Unemployment	Total Rate
1	50	\$23.52	\$12.28	\$5.21	\$0.00	\$41.01
2	60	\$28.22	\$12.28	\$19.45	\$0.00	\$59.95
3	65	\$30.57	\$12.28	\$19.45	\$0.00	\$62.30
4	75	\$35.27	\$12.28	\$19.45	\$0.00	\$67.00
5	85	\$39.98	\$12.28	\$19.45	\$0.00	\$71.71

**Notes:** \*\* 1:5, 2:6-10, the 1:10; Reroofing: 1:4, then 1:1  
 Step 1 is 2000 hrs.; Steps 2-5 are 1000 hrs.  
 (Hot Pitch Mechanics' receive \$1.00 hr. above ROOFER)

**Apprentice to Journeyworker Ratio:\*\***

ROOFER SLATE / TILE / PRECAST CONCRETE <i>ROOFERS LOCAL 33</i>	02/01/2022	\$47.28	\$12.28	\$19.45	\$0.00	\$79.01
For apprentice rates see "Apprentice- ROOFER"						
SHEETMETAL WORKER <i>SHEETMETAL WORKERS LOCAL 17 - A</i>	02/01/2022	\$53.70	\$13.80	\$25.60	\$2.79	\$95.89

**Classification**

**Effective Date    Base Wage    Health    Pension    Supplemental Unemployment    Total Rate**

**Apprentice - SHEET METAL WORKER - Local 17-A**

**Effective Date - 02/01/2022**

Step	percent	Apprentice Base Wage	Health	Pension	Supplemental Unemployment	Total Rate
1	42	\$22.55	\$13.80	\$6.01	\$0.00	\$42.36
2	42	\$22.55	\$13.80	\$6.01	\$0.00	\$42.36
3	47	\$25.24	\$13.80	\$11.26	\$1.51	\$51.81
4	47	\$25.24	\$13.80	\$11.26	\$1.51	\$51.81
5	52	\$27.92	\$13.80	\$12.23	\$1.62	\$55.57
6	52	\$27.92	\$13.80	\$12.48	\$1.63	\$55.83
7	60	\$32.22	\$13.80	\$13.87	\$1.80	\$61.69
8	65	\$34.91	\$13.80	\$14.84	\$1.91	\$65.46
9	75	\$40.28	\$13.80	\$16.77	\$2.13	\$72.98
10	85	\$45.65	\$13.80	\$18.20	\$2.33	\$79.98

**Notes:**  
Steps are 6 mos.

**Apprentice to Journeyworker Ratio:1:4**

SPECIALIZED EARTH MOVING EQUIP < 35 TONS <i>TEAMSTERS JOINT COUNCIL NO. 10 ZONE A</i>	12/01/2021	\$37.34	\$13.41	\$16.01	\$0.00	\$66.76
SPECIALIZED EARTH MOVING EQUIP > 35 TONS <i>TEAMSTERS JOINT COUNCIL NO. 10 ZONE A</i>	12/01/2021	\$37.63	\$13.41	\$16.01	\$0.00	\$67.05
SPRINKLER FITTER <i>SPRINKLER FITTERS LOCAL 550 - (Section A) Zone 1</i>	03/01/2022	\$64.36	\$10.44	\$22.10	\$0.00	\$96.90
	10/01/2022	\$66.06	\$10.44	\$22.10	\$0.00	\$98.60
	03/01/2023	\$67.76	\$10.44	\$22.10	\$0.00	\$100.30
	10/01/2023	\$69.51	\$10.44	\$22.10	\$0.00	\$102.05
	03/01/2024	\$71.31	\$10.44	\$22.10	\$0.00	\$103.85
	10/01/2024	\$73.11	\$10.44	\$22.10	\$0.00	\$105.65
	03/01/2025	\$74.91	\$10.44	\$22.10	\$0.00	\$107.45

**Classification**

**Effective Date    Base Wage    Health    Pension    Supplemental Unemployment    Total Rate**

**Apprentice - SPRINKLER FITTER - Local 550 (Section A) Zone 1**

**Effective Date - 03/01/2022**

Step	percent	Apprentice Base Wage	Health	Pension	Supplemental Unemployment	Total Rate
1	35	\$22.53	\$10.44	\$12.35	\$0.00	\$45.32
2	40	\$25.74	\$10.44	\$13.10	\$0.00	\$49.28
3	45	\$28.96	\$10.44	\$13.85	\$0.00	\$53.25
4	50	\$32.18	\$10.44	\$14.60	\$0.00	\$57.22
5	55	\$35.40	\$10.44	\$15.35	\$0.00	\$61.19
6	60	\$38.62	\$10.44	\$16.10	\$0.00	\$65.16
7	65	\$41.83	\$10.44	\$16.85	\$0.00	\$69.12
8	70	\$45.05	\$10.44	\$17.60	\$0.00	\$73.09
9	75	\$48.27	\$10.44	\$18.35	\$0.00	\$77.06
10	80	\$51.49	\$10.44	\$19.10	\$0.00	\$81.03

**Effective Date - 10/01/2022**

Step	percent	Apprentice Base Wage	Health	Pension	Supplemental Unemployment	Total Rate
1	35	\$23.12	\$10.44	\$12.35	\$0.00	\$45.91
2	40	\$26.42	\$10.44	\$13.10	\$0.00	\$49.96
3	45	\$29.73	\$10.44	\$13.85	\$0.00	\$54.02
4	50	\$33.03	\$10.44	\$14.60	\$0.00	\$58.07
5	55	\$36.33	\$10.44	\$15.35	\$0.00	\$62.12
6	60	\$39.64	\$10.44	\$16.10	\$0.00	\$66.18
7	65	\$42.94	\$10.44	\$16.85	\$0.00	\$70.23
8	70	\$46.24	\$10.44	\$17.60	\$0.00	\$74.28
9	75	\$49.55	\$10.44	\$18.35	\$0.00	\$78.34
10	80	\$52.85	\$10.44	\$19.10	\$0.00	\$82.39

**Notes:** Apprentice entered prior 9/30/10:  
40/45/50/55/60/65/70/75/80/85  
Steps are 850 hours

**Apprentice to Journeyworker Ratio:1:3**

STEAM BOILER OPERATOR <i>OPERATING ENGINEERS LOCAL 4</i>	12/01/2021	\$50.83	\$14.00	\$16.05	\$0.00	\$80.88
For apprentice rates see "Apprentice- OPERATING ENGINEERS"						
TAMPERS, SELF-PROPELLED OR TRACTOR DRAWN <i>OPERATING ENGINEERS LOCAL 4</i>	12/01/2021	\$50.83	\$14.00	\$16.05	\$0.00	\$80.88
For apprentice rates see "Apprentice- OPERATING ENGINEERS"						
TELECOMMUNICATION TECHNICIAN <i>ELECTRICIANS LOCAL 103</i>	03/01/2022	\$44.71	\$13.00	\$18.74	\$0.00	\$76.45
	09/01/2022	\$46.42	\$13.00	\$18.87	\$0.00	\$78.29
	03/01/2023	\$48.34	\$13.00	\$19.01	\$0.00	\$80.35

**Classification**

**Effective Date    Base Wage    Health    Pension    Supplemental Unemployment    Total Rate**

**Apprentice - TELECOMMUNICATION TECHNICIAN - Local 103**

**Effective Date - 03/01/2022**

Step	percent	Apprentice Base Wage	Health	Pension	Supplemental Unemployment	Total Rate
1	45	\$20.12	\$13.00	\$0.60	\$0.00	\$33.72
2	45	\$20.12	\$13.00	\$0.60	\$0.00	\$33.72
3	50	\$22.36	\$13.00	\$15.06	\$0.00	\$50.42
4	50	\$22.36	\$13.00	\$15.06	\$0.00	\$50.42
5	55	\$24.59	\$13.00	\$15.43	\$0.00	\$53.02
6	60	\$26.83	\$13.00	\$15.79	\$0.00	\$55.62
7	65	\$29.06	\$13.00	\$16.16	\$0.00	\$58.22
8	70	\$31.30	\$13.00	\$16.53	\$0.00	\$60.83
9	75	\$33.53	\$13.00	\$16.91	\$0.00	\$63.44
10	80	\$35.77	\$13.00	\$17.27	\$0.00	\$66.04

**Effective Date - 09/01/2022**

Step	percent	Apprentice Base Wage	Health	Pension	Supplemental Unemployment	Total Rate
1	45	\$20.89	\$13.00	\$0.63	\$0.00	\$34.52
2	45	\$20.89	\$13.00	\$0.63	\$0.00	\$34.52
3	50	\$23.21	\$13.00	\$15.13	\$0.00	\$51.34
4	50	\$23.21	\$13.00	\$15.13	\$0.00	\$51.34
5	55	\$25.53	\$13.00	\$15.51	\$0.00	\$54.04
6	60	\$27.85	\$13.00	\$15.88	\$0.00	\$56.73
7	65	\$30.17	\$13.00	\$16.26	\$0.00	\$59.43
8	70	\$32.49	\$13.00	\$16.62	\$0.00	\$62.11
9	75	\$34.82	\$13.00	\$17.00	\$0.00	\$64.82
10	80	\$37.14	\$13.00	\$17.37	\$0.00	\$67.51

**Notes:**

**Apprentice to Journeyworker Ratio:1:1**

TERRAZZO FINISHERS BRICKLAYERS LOCAL 3 - MARBLE & TILE	02/01/2022	\$56.09	\$11.39	\$22.34	\$0.00	\$89.82
---	------------	---------	---------	---------	--------	---------

**Apprentice - TERRAZZO FINISHER - Local 3 Marble & Tile**

**Effective Date - 02/01/2022**

Step	percent	Apprentice Base Wage	Health	Pension	Supplemental Unemployment	Total Rate
1	50	\$28.05	\$11.39	\$22.34	\$0.00	\$61.78
2	60	\$33.65	\$11.39	\$22.34	\$0.00	\$67.38
3	70	\$39.26	\$11.39	\$22.34	\$0.00	\$72.99
4	80	\$44.87	\$11.39	\$22.34	\$0.00	\$78.60
5	90	\$50.48	\$11.39	\$22.34	\$0.00	\$84.21

**Notes:**

**Apprentice to Journeyworker Ratio:1:3**

TEST BORING DRILLER <i>LABORERS - FOUNDATION AND MARINE</i>	12/01/2021	\$42.58	\$9.10	\$17.72	\$0.00	\$69.40
--	------------	---------	--------	---------	--------	---------

For apprentice rates see "Apprentice- LABORER"

TEST BORING DRILLER HELPER <i>LABORERS - FOUNDATION AND MARINE</i>	12/01/2021	\$41.30	\$9.10	\$17.72	\$0.00	\$68.12
---	------------	---------	--------	---------	--------	---------

For apprentice rates see "Apprentice- LABORER"

TEST BORING LABORER <i>LABORERS - FOUNDATION AND MARINE</i>	12/01/2021	\$41.18	\$9.10	\$17.72	\$0.00	\$68.00
--	------------	---------	--------	---------	--------	---------

For apprentice rates see "Apprentice- LABORER"

TRACTORS/PORTABLE STEAM GENERATORS <i>OPERATING ENGINEERS LOCAL 4</i>	12/01/2021	\$50.83	\$14.00	\$16.05	\$0.00	\$80.88
--	------------	---------	---------	---------	--------	---------

For apprentice rates see "Apprentice- OPERATING ENGINEERS"

TRAILERS FOR EARTH MOVING EQUIPMENT <i>TEAMSTERS JOINT COUNCIL NO. 10 ZONE A</i>	12/01/2021	\$37.92	\$13.41	\$16.01	\$0.00	\$67.34
---	------------	---------	---------	---------	--------	---------

TUNNEL WORK - COMPRESSED AIR <i>LABORERS (COMPRESSED AIR)</i>	12/01/2021	\$53.41	\$9.10	\$18.17	\$0.00	\$80.68
--	------------	---------	--------	---------	--------	---------

For apprentice rates see "Apprentice- LABORER"

TUNNEL WORK - COMPRESSED AIR (HAZ. WASTE) <i>LABORERS (COMPRESSED AIR)</i>	12/01/2021	\$55.41	\$9.10	\$18.17	\$0.00	\$82.68
---	------------	---------	--------	---------	--------	---------

For apprentice rates see "Apprentice- LABORER"

TUNNEL WORK - FREE AIR <i>LABORERS (FREE AIR TUNNEL)</i>	12/01/2021	\$45.48	\$9.10	\$18.17	\$0.00	\$72.75
---	------------	---------	--------	---------	--------	---------

For apprentice rates see "Apprentice- LABORER"

TUNNEL WORK - FREE AIR (HAZ. WASTE) <i>LABORERS (FREE AIR TUNNEL)</i>	12/01/2021	\$47.48	\$9.10	\$18.17	\$0.00	\$74.75
--	------------	---------	--------	---------	--------	---------

For apprentice rates see "Apprentice- LABORER"

VAC-HAUL <i>TEAMSTERS JOINT COUNCIL NO. 10 ZONE A</i>	12/01/2021	\$37.34	\$13.41	\$16.01	\$0.00	\$66.76
--	------------	---------	---------	---------	--------	---------

WAGON DRILL OPERATOR <i>LABORERS - ZONE 1</i>	06/01/2022	\$42.43	\$9.10	\$17.57	\$0.00	\$69.10
	12/01/2022	\$43.43	\$9.10	\$17.57	\$0.00	\$70.10
	06/01/2023	\$44.43	\$9.10	\$17.57	\$0.00	\$71.10
	12/01/2023	\$45.68	\$9.10	\$17.57	\$0.00	\$72.35

For apprentice rates see "Apprentice- LABORER"

WAGON DRILL OPERATOR (HEAVY & HIGHWAY) <i>LABORERS - ZONE 1 (HEAVY &amp; HIGHWAY)</i>	12/01/2021	\$41.43	\$9.10	\$17.57	\$0.00	\$68.10
--	------------	---------	--------	---------	--------	---------

For apprentice rates see "Apprentice- LABORER (Heavy and Highway)"



Classification	Effective Date	Base Wage	Health	Pension	Supplemental Unemployment	Total Rate
WASTE WATER PUMP OPERATOR <i>OPERATING ENGINEERS LOCAL 4</i>	12/01/2021	\$51.38	\$14.00	\$16.05	\$0.00	\$81.43
For apprentice rates see "Apprentice- OPERATING ENGINEERS"						
WATER METER INSTALLER <i>PLUMBERS &amp; GASFITTERS LOCAL 12</i>	03/01/2022	\$63.39	\$13.57	\$17.26	\$0.00	\$94.22
	09/04/2022	\$63.49	\$14.07	\$18.36	\$0.00	\$95.92
	02/26/2023	\$65.19	\$14.07	\$18.36	\$0.00	\$97.62
	09/03/2023	\$66.94	\$14.07	\$18.36	\$0.00	\$99.37
	03/03/2024	\$68.74	\$14.07	\$18.36	\$0.00	\$101.17
	09/01/2024	\$70.54	\$14.07	\$18.36	\$0.00	\$102.97
	03/02/2025	\$72.34	\$14.07	\$18.36	\$0.00	\$104.77
For apprentice rates see "Apprentice- PLUMBER/PIPEFITTER" or "PLUMBER/GASFITTER"						

**Additional Apprentice Information:**

Minimum wage rates for apprentices employed on public works projects are listed above as a percentage of the pre-determined hourly wage rate established by the Commissioner under the provisions of the M.G.L. c. 149, ss. 26-27D. Apprentice ratios are established by the Division of Apprenticeship Training pursuant to M.G.L. c. 23, ss. 11E-11L.

All apprentices must be registered with the Division of Apprenticeship Training in accordance with M.G.L. c. 23, ss. 11E-11L.

All steps are six months (1000 hours.)

Ratios are expressed in allowable number of apprentices to journeymen or fraction thereof, unless otherwise specified.

\*\* Multiple ratios are listed in the comment field.

\*\*\* APP to JM; 1:1, 2:2, 2:3, 3:4, 4:4, 4:5, 4:6, 5:7, 6:7, 6:8, 6:9, 7:10, 8:10, 8:11, 8:12, 9:13, 10:13, 10:14, etc.

\*\*\*\* APP to JM; 1:1, 1:2, 2:3, 2:4, 3:5, 4:6, 4:7, 5:8, 6:9, 6:10, 7:11, 8:12, 8:13, 9:14, 10:15, 10:16, etc.