

TOWN OF ARLINGTON

730 Massachusetts Avenue

Arlington, MA 02476



PROJECT MANUAL

Contract for

Pedestrian Safety Improvements

Chestnut Street

Invitation for Bid (IFB)

#23-27

TOWN OF ARLINGTON

DEPARTMENT OF PUBLIC WORKS

INVITATION FOR BID

The Town of Arlington invites sealed bids, pursuant to M.G.L. c.30, §39M, for

23-27 Pedestrian Safety Improvements – Chestnut Street

Bids will be received until **10:00 A.M., Thursday, April 20, 2023** at the Office of the Town Manager/Purchasing Department, 730 Massachusetts Ave, Arlington, MA 02476, at which time they will be publicly opened and read aloud.

The work under this contract consists of all labor, materials and equipment necessary to install traffic signal poles and flashing beacons in the vicinity of 17 Chestnut Street.

Bid documents are available for viewing and downloading on the Town's website at www.arlingtonma.gov/purchasing. Bids must be submitted on the forms provided therein and in a sealed envelope marked on the outside with the bidder's name, address, and phone number and with the words **Bid # 23-27 Pedestrian Safety Improvements – Chestnut Street**. No bid will be accepted after the time and date specified.

A bid deposit in the amount of five per cent (5%) of the bid amount and payable to the Town of Arlington shall be submitted with each bid. Bid deposits shall be in the form of (a) a certified check on, or a treasurer's or cashier's check issued by, a responsible bank or trust company, or (b) a bid bond in a form satisfactory to the Town, with a surety company qualified to do business in the Commonwealth of Massachusetts

The Town of Arlington will award the contract to the lowest eligible and responsible bidder. The Town Manager reserves the right to accept or reject any and all bids, wholly or in part, or to waive minor informalities in any or all bids, if it be in the public interest so to do.

The work shall begin within two weeks after execution and delivery of the contract and shall end on or before June 30, 2023.

Minimum Wage Rates, as determined by the Director of the Department of Labor Standards of the Executive Office of Labor and Workforce Development under the

provisions of M.G.L. c.149 §26 to 27H, apply to this project. The schedule of wage rates applicable to this contract is included in the bid documents.

The successful bidder will be required to provide

- a Certificate of Insurance demonstrating current coverage of the type and amounts set forth in the bid documents, and
- a Labor and Materials or Payment Bond in the amount of 50% of the contract total.

Questions regarding this Invitation to Bid should be directed to the Town of Arlington's Purchasing Agent at mdenatale@town.arlington.ma.us.

TOWN OF ARLINGTON

Sanford Pooler
Town Manager

April 6, 2023

I INSTRUCTIONS TO BIDDERS

A. COMPLEMENTARY DOCUMENT

1. The Invitation for Bid, included herewith, is complementary to this document and shall be carefully reviewed by bidders for specific instructions not repeated herein.

B. STATUTES REGULATING COMPETITIVE BIDDING

1. Bidding procedures and award of contract shall be in accordance with the provisions of to M.G.L. c.30, §39M.
2. In the event of any discrepancy or inconsistency between the provisions of the bid or contract documents and the statutes referenced hereinabove, the provisions of said statutes shall govern. In such event, the application of all remaining provisions not in conflict with any circumstance other than that in which the conflict occurs shall not be affected thereby.

C. BIDDER'S QUALIFICATIONS

1. No individual or firm may submit a bid unless it includes, with the bid form, a list of at least three (3) references from similar projects completed in the last five (5) years.
2. The Town Manager will reject bids when required to do so by Massachusetts General Laws. In addition, the Town Manager reserves the right to waive any informalities in bidding and to reject any and all bids if he deems it to be in the public interest so to do. The Town Manager reserves the right to reject any bid if he determines that such bid does not represent the bid of a person or firm competent to perform the work as specified, or if fewer than three bids are received, or if bid prices are not acceptable without further competition.

D. INTERPRETATION OF DOCUMENTS: NOTIFICATION OF ERRORS

1. Bidders are urged to notify the Town of any and all errors and discrepancies found in the bid and contract documents.
2. Bidders requiring interpretation or clarification of the bid and contract documents shall make a written request to the Purchasing Agent at mdenatale@town.arlington.ma.us. The Town will answer such requests if received at least six (6) days prior to the date of the bid opening.
3. Interpretations and clarification of the bid and contract documents will be made by Addendum which will become part of the bid and contract documents. The Town will not be held accountable for any oral instruction.

E. EXAMINATION OF BID AND CONTRACT DOCUMENTS

1. Each bidder shall carefully examine the bid and contract documents to obtain a thorough understanding of the work of her/his bid in addition to the work of related trades. In addition, each bidder shall personally visit the site to thoroughly acquaint her/himself with the conditions as they exist thereon.
2. Failure of any bidder to thoroughly examine the bid and contract documents or to visit and examine the site or to familiarize her/himself with local conditions under which the work must be performed shall in no way relieve her/him of any obligation with respect to her/his bid or of any responsibility assigned to her/him under the contract.

F. MODIFICATION AND WITHDRAWAL OF BIDS

1. Modification or withdrawal of bids will be permitted after submission of said bids provided that clearly written and readily understandable instructions are received by the Town Manager in writing prior to the time established for the opening of bids. No bid may be withdrawn after that time, except as otherwise provided herein or by law.
2. No bid may be withdrawn for a period of thirty (30) days, Saturdays, Sundays and legal holidays excluded, after actual date of bid opening.

G. ADDENDA

1. Designer's interpretations shall be in the form of Addenda to the bid and contract documents. Failure to receive such Addenda shall in no way relieve any bidder from the execution of its provisions. All bidders are cautioned to verify the number of Addenda that have been issued and to secure any needed copies from the Town before submitting a bid.
2. Bidders shall acknowledge each and every Addendum in the spaces provided on the bid form; failure of a bidder to do so may result in rejection of the bid.

H. BID FORM

1. Bids must be submitted on the forms attached hereto. The bid forms may be removed and submitted separately from the other documents.
2. All blank spaces on the bid form must be filled in and all entries must be made in ink or typewritten. Bidders must bid on each item. Where space is provided, sums shall be expressed in both words and figures. In case of a discrepancy between the two, the written words shall govern.
3. No interlineations, additions, alterations or erasures shall be made on the forms.

I. ALTERNATES

1. Not applicable.

J. SUBMISSION OF BIDS

1. The bid form shall be properly executed and enclosed with a bid deposit equal to five percent (5%) of the value of the total bid in a sealed envelope plainly marked on the outside with the name and address of the bidder and the words **Bid #23-27 Pedestrian Safety Improvements – Chestnut Street** along with the bidder's name, business address, and phone number.
2. If the bid is mailed, the aforementioned sealed envelope shall be enclosed in a second envelope marked on the outside with the same information above and mailed to the place of the bid opening, as stipulated in the Invitation for Bid. Mailed bids must be received before the time scheduled for opening of bids.

K. BID DEPOSITS

1. The bid deposit shall be submitted in the amount specified in the Invitation for Bid and in the form of (a) a certified check on, or a treasurer's or cashier's check issued by, a responsible bank or trust company and payable to the Town of Arlington, or (b) a bid bond in a form satisfactory to the Town, with a surety company qualified to do business in the Commonwealth of Massachusetts, and conditioned upon the faithful performance by the principal of the agreements contained in the bid. Return of bid deposits will be in accordance with the provisions of the applicable Massachusetts General Laws.
2. Bid deposits of all general bidders, except those of the three lowest responsible and eligible general bidders, shall be returned within five days, Saturdays, Sundays and legal holidays excluded, after the opening of the general bids. The bid deposits of the three lowest responsible and eligible general bidders shall be returned upon the execution and delivery of the general contract or, if no award is made, upon the expiration of the time prescribed in the applicable Massachusetts General Laws for making an award; except that, if any general bidder fails to perform her/his agreement to execute a contract and furnish any performance or payment bonds required herein, her/his bid deposit shall become and be the property of the Town, as liquidated damages.

L. PAYMENT BOND

1. In accordance with M.G.L. c.149, §29, the selected contractor will be required to submit a Labor and Materials or Payment bond, in the amount of fifty percent (50%) of the contract sum, from a surety company qualified to do business under the laws of the Commonwealth and approved by the Town.

M. FOREIGN CORPORATIONS

1. Attention of bidders is called to M.G.L. c.30, §39L, as amended, under which an Awarding Authority may not enter into a contract with a foreign corporation (defined as a corporation that has been established, organized, or chartered under laws other than those of the Commonwealth of Massachusetts), nor approve a foreign corporation as a sub-contractor, unless said foreign corporation has filed with the Authority a certificate of the State Secretary stating that the corporation has complied with requirements of Massachusetts General Laws, Chapter 156D, Section 15.03 and stating the date of such compliance.

N. AWARD OF CONTRACT

1. The Contract shall be awarded to the lowest responsible and eligible bidder, as provided under M.G.L. c.30, §39M.
2. The Town reserves the right to reject general bids in accordance with the provisions of M.G.L. c.30, §39M. In addition, the Town may consider informal and may reject any bid which is not prepared and submitted in accordance with all requirements of the bid documents, or which contains erasures, alterations, additions, errors or irregularities of any kind, or which contains proposed prices for any class or item of work which is, in the judgment of the Town, substantially less or more than the actual cost to complete the work; provided, however, that the Town reserves the right to waive any and all informalities as to form. Matters as to substance shall not be waived. Subject to the provisions of applicable laws, if the forms, specifications, or any other bid document require submission of special information or data to accompany bids for any trade, if applicable, and any bidder neglects to furnish such information or data with its bid, the Town may reject the bid of such bidder as incomplete; provided, however, that the Town reserves the right to deem any such omission as an informality for which such bid will not be rejected, and to subsequently receive such information or data prior to award of the contract. See paragraph C. above as to the Town's right to reject the bid of any bidder who is not qualified, competent and responsible.

O. COMMENCEMENT AND COMPLETION OF WORK

1. The successful bidder, upon execution of the contract agreement, shall commence the work of the contract within seven (7) calendar days from receipt of the written Notice to Proceed issued by the Town within fourteen (14) calendar days after said execution of the contract agreement, and shall therefore diligently and continuously carry out the work in such a manner as to substantially complete the work as noted herein.

P. LIQUIDATED DAMAGES

1. Liquidated damages for failure to complete the work within the time specified in the Invitation for Bid will be assessed by the Town in the amount stipulated therein. The liquidated damages of \$100.00 per calendar day is a minimum damage figure to compensate the Town for administrative costs and loss for delay of its use of the project, and for added Owner's Project Manager, Designer, and consultant fees, and does not limit in any way the liability of the contractor for damages in excess of the specified liquidated damages amount for other damages, in particular damages for breach of contract. It is expressly understood that such liquidated damages do not constitute a penalty.

Q. MASSACHUSETTS SALES AND USE TAX

1. Materials purchased for permanent installation in the work will be exempt from the Massachusetts Sales and Use tax. Each bidder shall consider this exemption in calculating her/his bid for the work.

R. OSHA TRAINING

1. Massachusetts law requires that all employees who work on Massachusetts public works construction sites must have no less than 10 hours of OSHA approved safety and health training. See M.G.L. c.30 §39M(c), M.G.L. c.30 §39S(a)(1), M.G.L. c.149 §44E(2), and M.G.L. c.149 §44F(2).

S. PAYMENT OF STATE TAXES

1. Bidders are required to certify that all state tax returns have been filed and all state taxes have been paid in order to be eligible to enter into a contract with the Town on this project. The form provided herein is to be used for this purpose and is to be completed and returned as part of the bid.

END OF SECTION

BID FORM Bid #23-27

To the Awarding Authority:

A. The Undersigned proposes to furnish all labor and materials required for:

Pedestrian Safety Improvements – Chestnut Street

in accordance with the accompanying plans and specifications for the lump sum contract price specified below, subject to additions and deductions according to the terms of the specifications.

B. This bid includes addenda numbered _____, _____, _____, _____,

C. The proposed contract price is _____
_____ dollars (\$_____)

D. The undersigned agrees that, if selected as general contractor, s/he will within five days, Saturdays, Sundays and legal holidays excluded, after presentation thereof by the awarding authority, execute a contract in accordance with the terms of this bid and furnish a labor and materials or payment bond, of a surety company qualified to do business under the laws of the commonwealth and satisfactory to the awarding authority and in a sum not less than fifty percent (50%) of the contract price, the premiums for which are to be paid by the general contractor and are included in the contract price.

E. The undersigned hereby certifies that s/he has carefully examined the bid and contract documents, established a thorough understanding of existing conditions, and has obtained sufficient information for executing the work of her/his bid and the work of all related trades.

F. The undersigned further certifies that s/he is able to furnish labor that can work in harmony with all other elements of labor employed or to be employed on the work and that s/he will comply fully with all laws and regulations applicable to awards made subject to Massachusetts General Laws, Chapter 30, Section 39M, and all other applicable laws.

G. The undersigned further certifies that all employees to be employed at the worksite will have successfully completed a course in construction safety and health approved by the United States Occupational Safety and Health Administration (OSHA) that is at least 10 hours in duration at the time the employee begins work and who shall furnish documentation of successful completion of said course with the first certified payroll report for each employee.

- H. The undersigned further certifies under the penalties of perjury that this bid is in all respects bona fide, fair, and made without collusion or fraud with any other person. As used in this subsection the word "person" shall mean any natural person, joint venture, partnership, corporation or other business or legal entity.
- I. The undersigned further certifies under the penalties of perjury that said undersigned is not presently debarred from doing public construction work in the commonwealth under the provisions of Massachusetts General Laws, Chapter 29, Section 29F, or any other applicable debarment provisions of any other chapter of the General Laws or any rule or regulation promulgated thereunder.

DATE _____

(Name of General Bidder)

Signed _____

(Printed Name and Title of Signatory)

(Business Street Address)

(City, State, Zip Code)

_____/_____
(Business Telephone/FAX)

(Business Email Address)

BIDDER’S QUALIFICATIONS AND REFERENCES

Please type or print legibly. If necessary, add additional sheets for starred items. This information will be utilized by the Town of Arlington for purposes of determining bidder responsiveness and responsibility with regard to the requirements and specifications of this contract. This form must be attached by the bidder to her/his completed bid form.

1. Firm name _____

2. Number of years bidder has done business under its present name _____

*3. Has the bidder ever failed to complete a contract awarded to her/him?
____ YES ____ NO

If yes, where and why _____

*4. List all work the bidder has completed within the past 5 years that is comparable in scope, complexity and value to that of the work of this contract. Bidder must list a **minimum of three** such projects.

Project Name/Location _____

Owner Name/Address _____

Construction Value _____ Date Completed _____

Type of Work _____

Contact Person _____ Telephone No. _____

Project Name/Location _____

Owner Name/Address _____

Construction Value _____ Date Completed _____

Type of Work _____

Contact Person _____ Telephone No. _____

Project Name/Location _____

Owner Name/Address _____

Construction Value _____ Date Completed _____

Type of Work _____

Contact Person _____ Telephone No. _____

Project Name/Location _____

Owner Name/Address _____

Construction Value _____ Date Completed _____

Type of Work _____

Contact Person _____ Telephone No. _____

Project Name/Location _____

Owner Name/Address _____

Construction Value _____ Date Completed _____

Type of Work _____

Contact Person _____ Telephone No. _____

Project Name/Location _____

Owner Name/Address _____

Construction Value _____ Date Completed _____

Type of Work _____

Contact Person _____ Telephone No. _____

CERTIFICATE OF NON-COLLUSION

(submit as part of completed bid form)

The undersigned certifies under the penalties of perjury that this bid is in all respects bond fide, fair and made without collusion or fraud with any other person. As used herein, the word "person" shall mean any natural person, joint venture, partnership, corporation, or other business or legal entity.

Name of Individual Authorized to Sign (Print or Type)

Authorized Signature

Legal Name of Business Entity (Print or Type)

STATEMENT OF STATE TAX COMPLIANCE

Pursuant to M.G.L. c.62C, §49A, I certify under the penalties of perjury that I have complied with all laws of the commonwealth relating to taxes, reporting of employees and contractors, and withholding and remitting child support.

Social Security Number or
Federal Identification Number

Signature of Individual or Responsible
Corporate Officer and Title

II. Location of Work

Work under this contract will include the installation of a Rectangular Rapid Flashing Beacon (RRFB) Pedestrian Crosswalk System on Chestnut Street, Arlington MA within a newly installed curb extension/bump-out adjacent to 17 Chestnut St. near the corner of Chestnut Street and Chestnut Terrace.

III. Proposal

By submitting a bid, the bidder certifies that:

- a. The only persons or parties interested in the proposal as Principals are named in this proposal;
- b. The proposal is made without collusion with any other Person, firm or corporation;
- c. They have carefully examined the requirements of the proposed work;
- d. The proposal is based solely on his own investigation and research and not in reliance upon any survey, report or representations of any employee, officer or agent of the TOWN; and the undersigned proposes and agrees that if this proposal is accepted, he will contract with the TOWN, this Contract Bid Form being part of and included in said CONTRACT, to provide all necessary supervision, labor, equipment, machinery, tools, apparatus, and other means of service necessary to complete the requirements in the CONTRACT.

IV. Scope of Work

This work shall consist of furnishing and installing a Rectangular Rapid Flashing Beacon (RRFB) Pedestrian Crosswalk System as shown and in conformance with these specifications, details and sketches.

Included in the work is the furnishing and installing, modifying, removing, resetting, stacking or transporting existing control equipment, signal beads, electric lamps, posts and bases, poles, pedestals, mast arms, barriers, barrier arrows, service connections, wire and cable, pull and junction boxes, electrical conduits, and all incidental materials necessary for operating and controlling the beacons, signs and arrows.

The locations of beacons, signs, barriers, control equipment and appurtenances shown on the plans are approximate and the exact location will be established by the Engineer in the field.

General

All work done under this contract shall be in conformance with the COMMONWEALTH OF MASSACHUSETTS DEPARTMENT OF TRANSPORTATION STANDARD SPECIFICATIONS FOR HIGHWAYS AND BRIDGES DATED 2022, THE SUPPLEMENTAL SPECIFICATIONS DATED JUNE 30, 2022, MASSACHUSETTS DEPARTMENT OF TRANSPORTATION OVERHEAD SIGNAL STRUCTURE STANDARD DRAWINGS DATED 2015, 2009 MANUAL ON UNIFORM TRAFFIC CONTROL DEVICES; REV. JULY 2022, the MASSACHUSETTS AMENDMENTS TO 2009 MANUAL ON UNIFORM TRAFFIC CONTROL DEVICES FOR STREETS AND HIGHWAYS AS DATED NOV. 2022 and these SPECIAL PROVISIONS.

V. Special Provisions

1. Definition of Terms

All reference to Department herein and in the Commonwealth of Massachusetts, Standard Specifications for Highways and Bridges, 1988, shall refer to the Owner" as the Department of Public Works of the Town of Arlington."

2. Work Schedule

Work on this project is restricted to a standard 8-hour day, 5-day week, with the Prime Contractor and all Subcontractors working on the same shift. No work shall be performed on this Contract on Saturdays, Sundays, or Holidays without permission from the owner.

3. Time of Completion

The work specified under this contract shall begin within 2 weeks of signed contract and be completed no later than August 15, 2023.

4. Performance, Labor and Material Bonds

A bond in the sum 50% of the total amount of the Contract by the successful bidder and an additional bond in equal amount covering the payment for all labor and materials used in the work shall be required. A surety company authorized to do business in Massachusetts and satisfactory to the Town of Arlington must provide these bonds. These bonds shall be required at the execution of the Contract. Attorneys-in-fact who sign contract bonds must file with each bond a certified and effectively dated copy of their power of attorney.

5. Bid Submission

Each bid must be submitted in a sealed envelope bearing on the outside the name of the bidder, his/her address, and the name of the project for which the bid is submitted, and the name and number of the Contract for which the bid is submitted. If forwarded by mail, the sealed envelope containing the bid must be enclosed in another envelope addressed as follows:

Bid Documents
Purchasing Director
BID # 23-27 CHESTNUT STREET PEDESTRIAN SAFETY IMPROVEMENTS
Town of Arlington
Town Hall, 730 Massachusetts Avenue
Arlington, Massachusetts 02476

The Owner will receive sealed bids until the time, and at the location designated in the Notice to Contractors. Bids received after this time will not be accepted. All interested parties are invited to attend; bids shall be opened publicly and read aloud.

6. Interpretation of Basic Estimate of Quantities

Attention is directed to the fact that the quantities of work to be done are based on observations and available data. The estimated quantities are approximate and should be used only as a guide. No quantities are guaranteed under this contract.

7. Prosecution of Work and Provisions for Travel

The Contractor shall give notice in writing to the Engineer at least seven days in advance of beginning any work affecting the maintenance of traffic where work affects the street in use by the public.

Before starting any work under this Contract, the Contractor shall submit his schedule of operations as provided herein.

The Contractor must prosecute the work efficiently and with the least possible delay.

The Contractor shall provide safe and convenient means of access to all buildings of property along the line of work at all times, coordinate the scheduling of safety and traffic details with the Arlington Police Department, and provide notification to the Arlington Department of Public Works and direct abutters at least one (1) business day prior to commencement of work adjacent to said abutter property.

8. Provisions for Access at All Locations

The Contractor shall cooperate with the various utility companies and provide access through a worksite if required for their work in connection with this project.

All permanent and temporary surfaces open for traffic during construction shall be maintained by the Contractor, as directed, in accordance with the provisions of herein.

THE TOWN WILL NOT ACCEPT ANY MATERIALS DELIVERED TO ANY PROJECT IN MOTOR VEHICLES OR SEMI-TRAILER UNITS THAT EXCEED THE LEGAL MAXIMUM GROSS WEIGHT ALLOWED FOR THE PARTICULAR CLASS, AS SPECIFIED IN SECTION 19 A OF CHAPTER 90 OF THE GENERAL LAWS OF MASSACHUSETTS.

9. Insurance Requirements

The limits of the several kinds of liability insurance required for this Contract, in addition to insurance for Workmen's Compensation are as listed as follows:

- a. Bodily Injury Liability insurance, in an amount not less than Five Hundred Thousand Dollars (\$500,000) for injuries, including wrongful death to any one person, and subject to the same limit for each person to an amount of not less than One Million Dollars (\$1,000,000) as account of one accident.
- b. Broad Form Property Damage Liability Insurance in an amount not less than Five Hundred Thousand Dollars (\$500,000) for damages on account of any one accident, and in an amount not less than One Million Dollars (\$1,000,000) for damages on account of all accidents.
- c. Automobile Bodily Injury Liability Insurance, in an amount not less than Five Hundred Thousand Dollars (\$500,000) for injuries, including wrongful death to any one person and subject to the same limit for each person in an amount not less than One Million Dollars (\$1,000,000) on account of one accident.
- d. Automobile Property Damage Insurance in an amount not less than Five Hundred Thousand Dollars (\$500,000) for damages on account of any one accident and in an amount not less than One Million Dollars (\$1,000,000) for damages on account of all accidents.
- e. Contractors Public Liability Insurance in an amount not less than Five Hundred Thousand Dollars (\$500,000) for each occurrence and in an amount not less than One Million Dollars (\$1,000,000) annual aggregate.

10. Maintenance of Traffic

During construction, the Contractor shall maintain two way traffic at all times. The Contractor shall make every effort to maintain access to all drives at all times. If access to any drives cannot be maintained, the Contractor shall notify the Engineer and persons affected, in writing, at least one (1) week in advance of the planned discontinuance. In any case, the access shall not be discontinued for more than two (2) consecutive days without obtaining the written authorization of the Engineer.

A minimum of 24-hours prior to commencing work, the permit applicant shall contact the Town of Arlington Police Department to determine if a Police Safety Detail will be required for the proposed work.

The use of a Police Safety Detail does not eliminate the need for proper warning signs and traffic control devices during the course of construction.

It shall be the sole responsibility of the contractor to provide & employ appropriate construction signage and barriers/cones/etc as needed. All signs and devices shall be in accordance with the Manual on Uniform Traffic Control Devices for Streets and Highways and all applicable MassDOT necessary by the Department of Public Works and/or Police Department for the safe and efficient performance of the

During the entire course of work, the applicant and/or owner shall be responsible to properly delineate & protect the job site in accordance with current MUTCD Standards to the full satisfaction of the work being suspended at the discretion of the Town of Arlington.

Reflective barrels, construction signage and other devices deemed necessary by the Engineer shall be utilized to direct vehicular and pedestrian traffic safely through the construction zone. All work left unattended shall be plated or ramped and suitable work safety devices and methods shall be utilized as necessary. All sidewalks and ramps shall be barricaded with reflective barrels and warning flagging where surfaces are impaired. If determined, signs may be needed on sidewalks to direct pedestrians around construction zone. Temporary stop and one-way signs may be needed until permanent signs are installed.

All signs, barricades, and barrels shall be in accordance with materials Specification M9.30.2 of the Department's "Standard Specifications for Highways and Bridges, 1988 Edition.

11. Protection of Utilities and Property

The Contractor shall be responsible for maintenance and protection of all utilities and shall repair at his/her own expense any damage to such structures caused by his/her act or neglect, and shall leave them in as good condition as they were previous to the commencement of the work. In cases of damage to utilities caused by him resulting in an emergency, the Contractor shall promptly warn the Owner and shall, if requested, furnish laborers to work temporarily under the Owner's direction in getting access to the utility. Pipes or other structures damaged by the operation of the Contractor may be repaired by the Town, Department or Company, which suffers the loss. The cost of such repairs shall be at the expense of the Contractor.

12. Notice to Owners of Utilities

When necessary, written notice shall be given by the Contractor to all public service corporations or officials owning or having charge of publicly or privately owned utilities of his/her intention to commence operations affecting such utilities at least one week in advance of the commencement of such operations, and the Contractor shall at that time file a copy of such notice with the Engineer.

Before the Contractor begins any work or operations, which might damage any subsurface structures, he shall carefully locate all such structures and conduct his/her operations so as to avoid any damage to them. The following are the names and addresses of the utilities presumed to be affected, but the completeness of the list is not guaranteed:

Town of Arlington
Town Engineer, Wayne A. Chouinard P.E. (781- 316- 3320)
51 Grove Street
Arlington, MA. 02476

Town of Arlington
Water/Sewer/Highway, Operations, Dan Warren (781-316 -3314)
51 Grove Street
Arlington, MA 02476

National Grid (Gas) (781-466-5280)
Operations: William Costigan
40 Sylvan Road
Waltham, MA 02451

Verizon (1-617-694-430)
Joe Ardizzoni (617-694-4304)
Stan Usovicz (978-750-5656)
63 High Street
Danvers, Ma. 01923

Eversource (781-441-8137)
Elaine Zimmerman
One Nstar Way SW-340
Westwood, MA 02090

VI Construction Methods and Material Specifications

1. Project Specifications

Project requirements shall adhere to equipment specifications included with attached Specifications and Sketches following this section.

2. Police Details.

The Contractor only on approval of the Engineer shall request Police Details. The Contractor shall call in for a detail by 4:00 P.M. the previous business day. The Contractor will be responsible for cancellation of any Police Details and shall make such cancellation call at least 1 hour prior to scheduled start time. Police Details shall have the authority to control any full or partial road or sidewalk closure or detour as it pertains to Public Safety. The Contractor shall fully comply with any reasonable request of the Police Detail for cones, barrels, signs, etc.

3. Time for Completion and Liquidated Damages

All work proposed under this contract, shall be completed by the specified date in this Contract. In case the Contractor fails to satisfactorily complete the entire work provided under this contract within one year, the Contractor agrees to pay the Town liquidated damages for failure to complete the project in conformance with the time allowances set forth above at the rate of (\$100.00) per calendar day (Sundays and legal holidays excluded). No work shall be done between November 15th. and April 15th without the express consent of the Director of Public Works.

4. Guarantee

The Contractor guarantees that the work to be done under this contract, and the workmanship performed and the materials and equipment used in the construction of the same, shall be free from defects or flaws, that each item of equipment shall be in accordance with the specifications, that the strength of all parts of all manufactured equipment shall be adequate and that the performance test requirements of the specifications shall be fulfilled. This guarantee shall be for a period of one year from and after the date of completion of the work as stated in final estimate. The Contractor shall repair or replace as required, promptly and without charge, all work, equipment, and material, or parts thereof, which during one year which fail to meet the above guarantee during one year herein quoted.

It is hereby, however, agreed and understood that this guarantee shall not include any repairs or replacements made necessary by any cause or causes other than improper, inadequate, or defective work, workmanship, materials, or design by the Contractor or those employed directly or indirectly by him.

DEFINITIONS OF ITEMS

1. INSTALLATION OF RECTANGULAR RAPID FLASHING BEACONS (RRFB): Work shall consist of the installation of a fully functional Rectangular Rapid Flashing Beacon System as indicated on attached “Proposed RRFB Project Package including Flashing Beacons, Signs, Pedestrian Push Buttons, Solar Panels, Batteries, connection equipment, installation of hardware, software and/or programming, foundations and poles as required by manufacturer recommendations. Final project completion to result in an activated and fully operational system as detailed on the sketches and accompanying bid documents.

Payment shall be made by the LUMP SUM (LS).

2. MAJOR ITEM LIST:

Solar Powered Rectangular Rapid Flash Beacon (RRFB) Pedestrian Crosswalk System to include all hardware, software, programming, signs, mounting hardware, pole and base cover. (Concrete Foundation to be provided by and installed by others) System shall include duplicative requirements – two (2) poles, two (2)-sided with signs and flashers facing in each direction including the following:

<u>Quantity</u>	<u>Description</u>
(2)	Concrete Pedestal Footings furnished and installed by Town
(2)	15 ft Traffic Signal Posts (STEEL)
(2)	APS Pedestrian Push Button, with communication capability, locating tone and sign with braille indicators.
(4)	Double, Dual RRFB-XL light bars above & below "arrow" placard; both directions
(2)	R10-25 Signs; with braille
(2)	W11-2 Pedestrian Crossing Sign (30" x 30")
(2)	W11-2 Pedestrian Crossing Sign (30" x 30") (MIRROR IMAGE)
(2)	W16-7pL, "left arrow" placard
(2)	W16-7pR, "right arrow" placard
(2)	85-watt solar panel and 105Ah battery capacity
(2)	NEMA Enclosures for all Components necessary to meet Functional Requirements per Special Provisions
(2)	Battery Systems
(1)	All mounting and supporting hardware, wiring, programming and setup

NOTES:

- 1) All signs shall be compliant with MUTCD requirements including retroreflectivity.
- 2) Contractor to coordinate site visit with Arlington Police Department and DPW; Engineering Division prior to installation to determine installation locations.
- 3) Contractor to coordinate site visit with Arlington Police Department and DPW; Engineering Division prior to installation to determine installation locations.

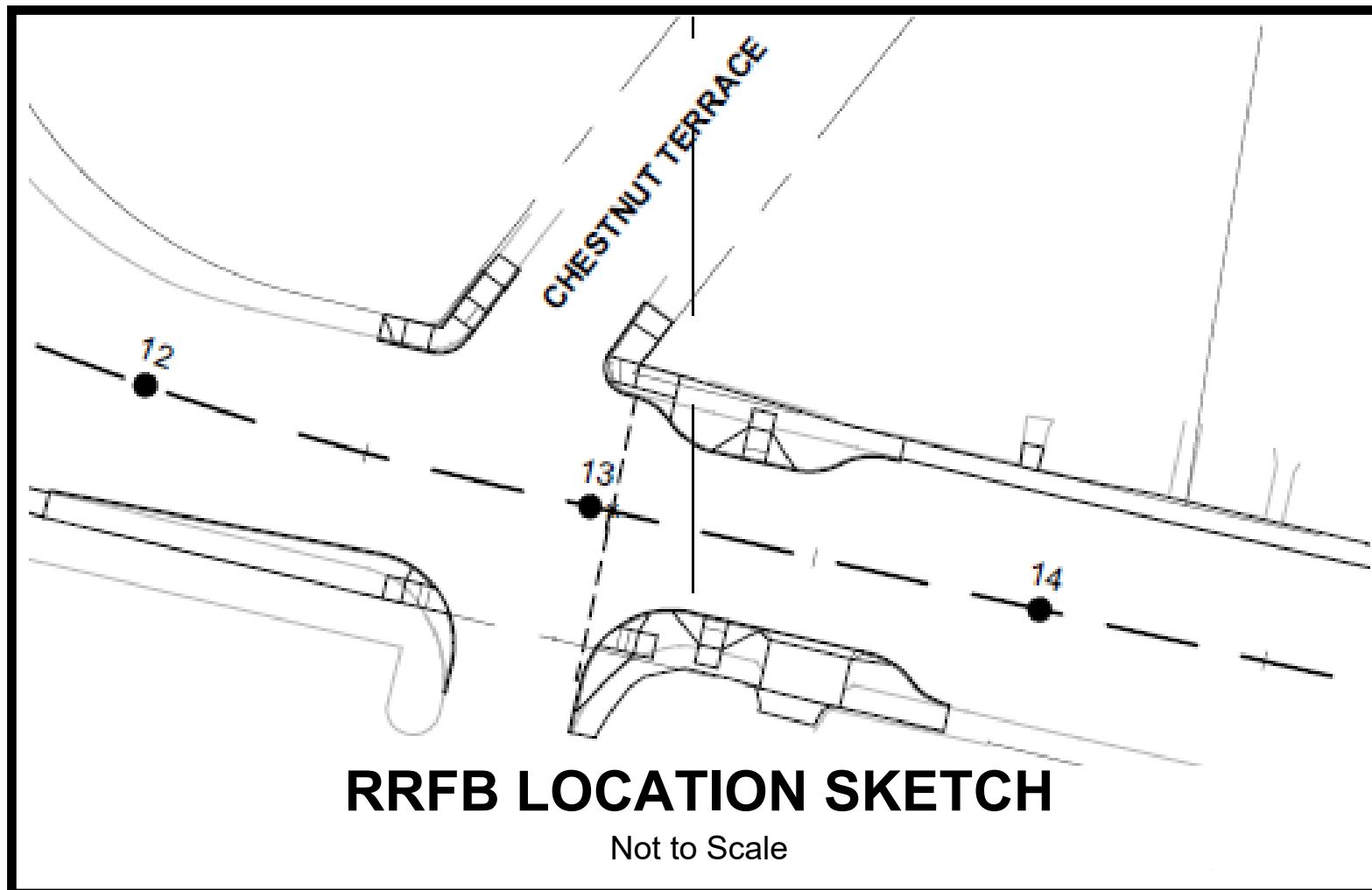
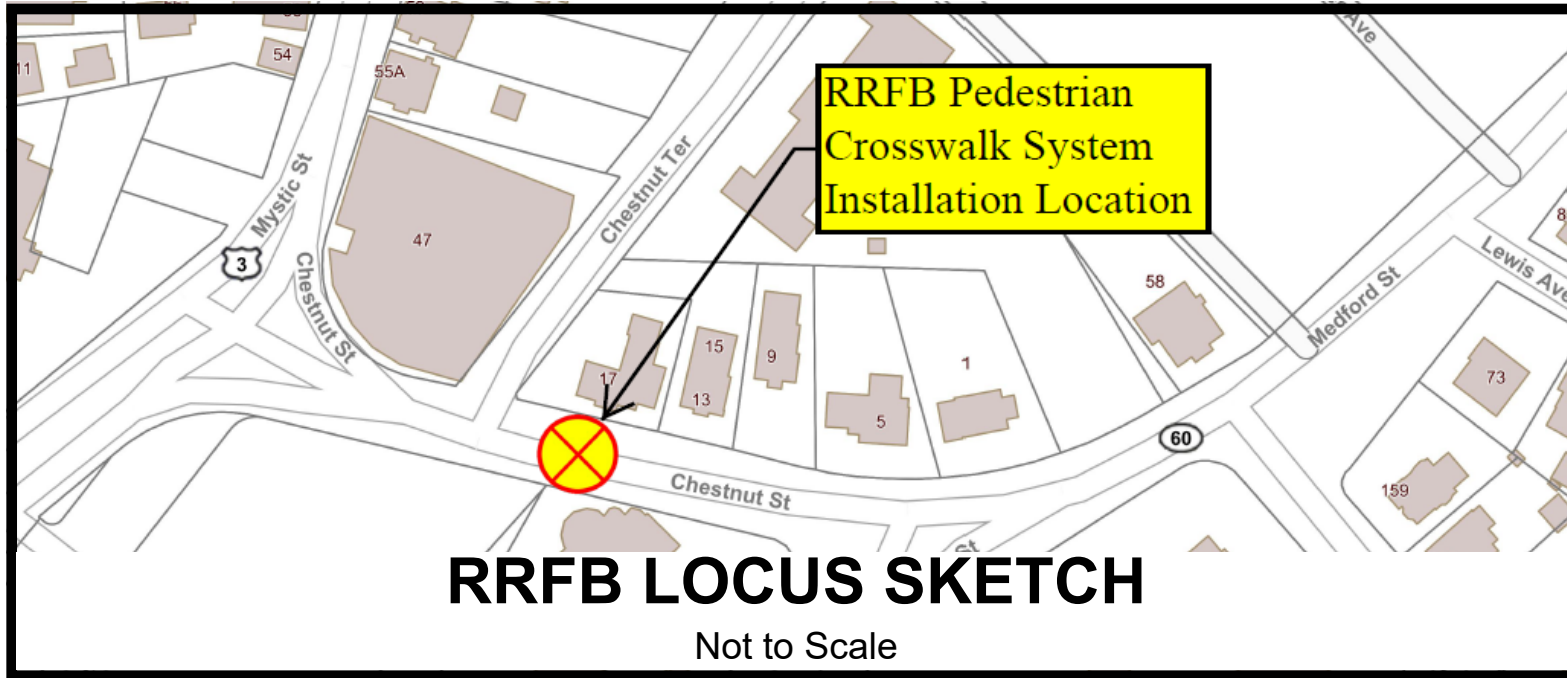

General Notes

1. Notes

Town of
ARLINGTON
Engineering Division
51 Grove Street
Arlington, MA 02476

**RRFB
PROJECT PACKAGE
Location & Locus
Sketch**

Project: RRFB	Sheet:
Drawn By: WAC	1 of 5
Scale: Not to Scale	
Date: April 4, 2023	

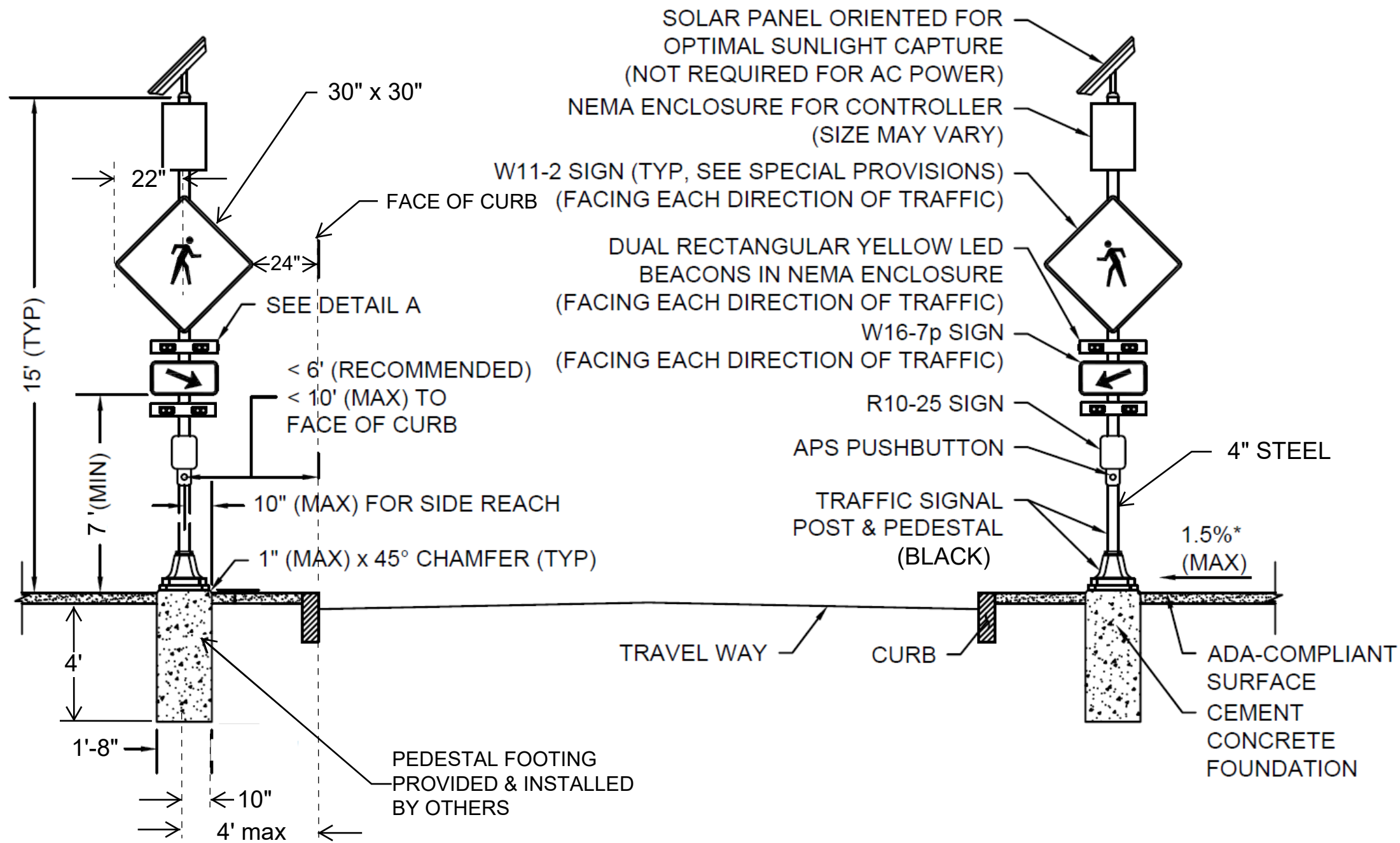

RRFB DETAIL #1
Not to Scale

General Notes

1. Notes

Town of
ARLINGTON
Engineering Division
 51 Grove Street
 Arlington, MA 02476

RRFB
PROJECT PACKAGE
Detail Sheet #1

Project:	RRFB	Sheet:	2 of 5
Drawn By:	WAC		
Scale:	Not to Scale		
Date:	April 4, 2023		

RRFB MAJOR ITEM LIST	
QUANTITY	DESCRIPTION
2	CONCRETE PEDESTAL FOOTINGS (FURNISHED & INSTALLED BY TOWN)
2	15' TRAFFIC SIGNAL POSTS
2	APS PUSH BUTTON SYSTEMS
4	DOUBLE - DUAL RECTANGULAR YELLOW LED BEACONS IN NEMA ENCLOSURES
2	R10-25 SIGNS; with BRAILLE
4	W11-2 SIGNS (30" x 30") (2 shall be Mirror Image)
2	W16-7pR SIGNS (24" x 12")
2	W16-7pL SIGNS (24" x 12")
2	SOLAR PANEL SYSTEM
2	NEMA ENCLOSURES FOR ALL COMPONENTS NEEDED TO MEET FUNCTIONAL REQUIREMENTS PER SPECIAL PROVISIONS
2	BATTERY SYSTEMS
-	ALL MOUNTING & SUPPORTING HARDWARE, WIRING, PROGRAMMING & SETUP NEEDED TO COMPLETE WORKING SYSTEM

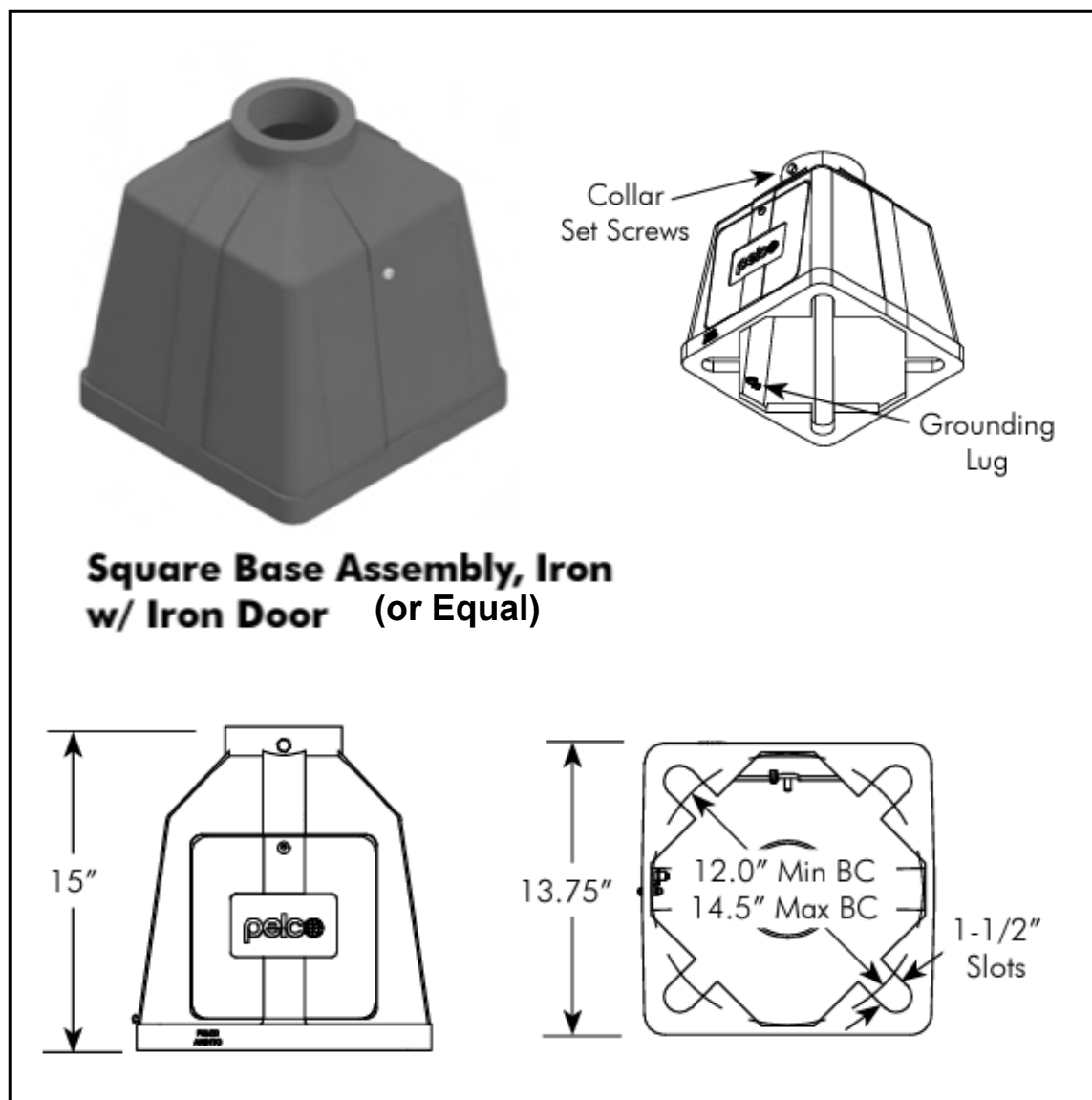
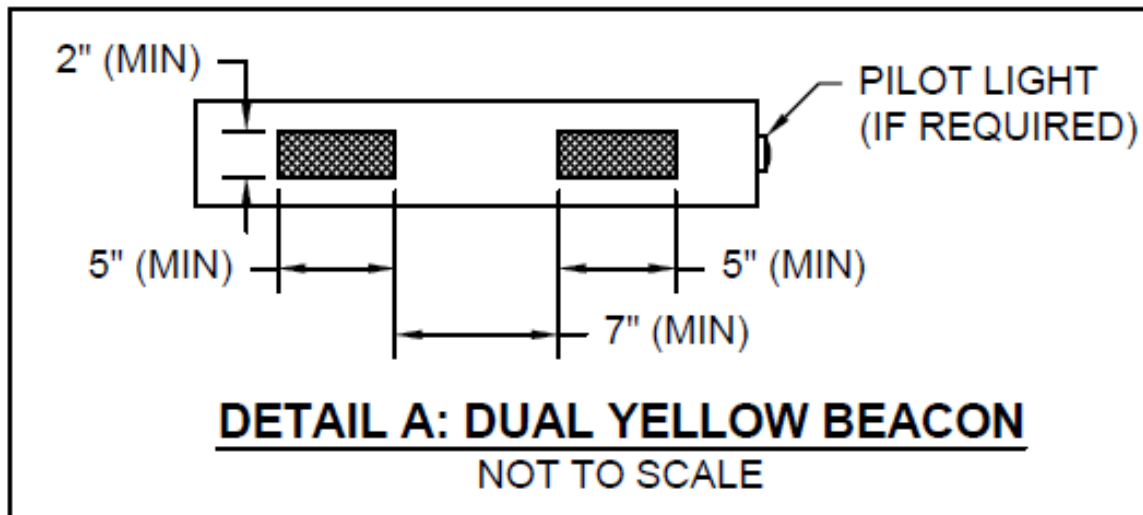

RRFB DETAIL #2
Not to Scale

General Notes
1. Notes

Town of
ARLINGTON
Engineering Division
51 Grove Street
Arlington, MA 02476

**RRFB
PROJECT PACKAGE
Detail Sheet #2**

Project: RRFB	Sheet:
Drawn By: WAC	3 of 5
Scale: Not to Scale	
Date: April 4, 2023	

DESCRIPTION

The work shall include furnishing and installing a solar-powered, pedestrian actuated, rectangular rapid flashing beacon (RRFB) system at the location shown in the plans.

MATERIALS

An RRFB system shall, at a minimum, consist of the following items, which shall be included in the lump sum bid:

- (2) concrete foundations; (To be furnished and installed by Town)
- (2) 15' traffic signal posts and pedestals;
- (2) APS pushbutton systems; with locating tone and communication capability
- (4) Double - dual rectangular yellow LED beacons in NEMA enclosures;
- (2) 9" x 12" R10-25, (PUSH BUTTON TO TURN ON WARNING LIGHTS) signs; with braille for visually impaired
- (2) 30" x 30" W11-2, (Pedestrian Warning) signs;
- (2) 30" x 30" W11-2, (Pedestrian Warning) signs, with Mirror Image;
- (2) 24" x 12" W16-7pR
- (2) 24" x 12" W16-7pL (Diagonal Downward Arrow) signs;
- (2) solar panels;
- (2) NEMA Type 3R or higher enclosures to house:

Electrical components, including wiring and solid-state circuit boards;

On-board user interface;

Battery; 85-watt solar panel and 105Ah battery capacity and

Frequency hopping spread spectrum (or other alternate FCC approved) wireless activation unit with a minimum 150' range; and

All mounting and supporting hardware and wiring necessary to complete a working system. RRFB controller and LED beacons, APS pushbutton systems, and traffic signal posts and pedestals shall be listed on the Qualified Traffic Control Equipment List. Pedestals shall be cast iron.

The light intensity of the LED beacons during daytime conditions shall meet the minimum specifications for Class 1 yellow peak luminous intensity in the Society of Automotive Engineers (SAE) Standard J595 (Directional Flashing Optical Warning Devices for Authorized Emergency, Maintenance, and Service Vehicles) dated January, 2005. An automatic signal dimming device shall be included to reduce the brilliance of the LED beacons during nighttime conditions.

MATERIALS (continued)

All signs shall be MUTCD-compliant. R10-25 signs shall have a black border and legend on a white background. W11-2, W16-7pR, and W16-7pL signs shall have a black border and legend on a fluorescent yellow-green background. All sign sheeting materials shall be per Subsection 828.41.

R10-25 signs may be integrated into the APS pushbutton system as a single unit or mounted separately on Type A aluminum with appropriate braille assistance.

W11-2, W16-7pR, and W16-7pL signs shall be Type A aluminum per Subsection 828.42.

Any proprietary software required for the programming and/or operation of the system shall be included at no additional cost.

The solar panels shall be affixed to an aluminum plate and bracket, adjustable at an angle of 45° to 60° and each assembly shall be mounted on a 360° rotatable pole cap mount to facilitate adjustment for maximum solar collection and optimal battery strength. The solar panel assemblies shall be rated for 90 mph wind conditions.

The batteries shall conform to Battery Council International specifications and have a capacity allowing up to 30 days of autonomy without sunlight and varying with ambient temperature and number of activations. The batteries shall be rated for a minimum lifespan of 5 years. Batteries shall be replaceable independently of other components.

The solar panels and battery shall have a minimum operating temperature range of -40° to 122°F (-40° to 50°C).

The Contractor shall provide shop drawings and calculations to confirm solar panel sizing and battery/solar energy storage will meet the functional requirements of the system.

FUNCTIONAL REQUIREMENTS

The RRFB system shall remain dark until pedestrian actuation.

Upon actuation, all LED beacons shall activate and flash in a rapidly flashing sequence. Each sequence shall last 800 milliseconds and there shall be 75 sequences per minute. The sequence shall be the same for each pair of LED beacons in an enclosure and shall be as follows:

See Sheet 4 of 4

General Notes

1. Notes

Town of
ARLINGTON
Engineering Division
51 Grove Street
Arlington, MA 02476

RRFB PROJECT PACKAGE Specifications

Project:	RRFB	Sheet:	4 of 5
Drawn By:	WAC		
Scale:	Not to Scale		
Date:	April 4, 2023		

RECTANGULAR RAPID FLASHING BEACON (RRFB) SPECIFICATIONS

FUNCTIONAL REQUIREMENTS (Continued)

The RRFB indication on the left-hand side shall be illuminated for approximately 50 milliseconds.

Both RRFB indications shall be dark for approximately 50 milliseconds.

The RRFB indication on the right-hand side shall be illuminated for approximately 50 milliseconds.

Both RRFB indications shall be dark for approximately 50 milliseconds.

The RRFB indication on the left-hand side shall be illuminated for approximately 50 milliseconds.

Both RRFB indications shall be dark for approximately 50 milliseconds.

The RRFB indication on the right-hand side shall be illuminated for approximately 50 milliseconds.

Both RRFB indications shall be dark for approximately 50 milliseconds.

Both RRFB indications shall be illuminated for approximately 50 milliseconds.

Both RRFB indications shall be dark for approximately 50 milliseconds.

Both RRFB indications shall be illuminated for approximately 50 milliseconds.

Both RRFB indications shall be dark for approximately 250 milliseconds.

The flash rate of each individual RRFB indication, as applied over the full flashing sequence, shall not be between 5 and 30 flashes per second.

All RRFBs within the system shall commence and cease operation simultaneously.

The length of the flashing cycle upon actuation and the minimum allowable time between actuations shall be per the plans. These settings shall be user-programmable through the on-board user interface. No-fee wireless (Wi-Fi, Bluetooth®, etc.) may be used as an alternative programming method.

Each APS pushbutton shall have a tactile arrow and locator tone. The tactile arrow shall be oriented to point in the direction of the crosswalk. The locator tone shall have a duration of 0.15 seconds or less and shall repeat at 1-second intervals. The locator tone shall be set 2 to 5 dBA above ambient sound, shall automatically adjust intensity, but cap at a maximum volume of 100 dBA. The tone shall be audible whenever the LED modules are not active.

Upon activation of the LED modules, a speech message shall state, "Yellow lights are flashing." This message shall be stated twice. No vibrotactile or percussive indications shall be used.

FUNCTIONAL REQUIREMENTS (continued)

If a pushbutton is pressed before the minimum time between actuation intervals is met, a speech message shall state, "Wait," and the locator tone shall resume until the LED modules activate.

CONSTRUCTION METHODS

No work shall commence until the shop drawings are approved.

Layout and design of the RRFB system shall conform to the plans.

Foundation installations shall be per Subsection 801.62. The top of the foundation shall be ¼" to 1" proud of the sidewalk and chamfered at 45 degrees. Gaps between the sidewalk and foundation shall be no larger than ¼" and grouted with preformed joint filler.

The Contractor shall diagnose and replace any part of the pedestrian activated warning system that is found to be defective in workmanship, material, or manner of functioning within six months of final acceptance by the Engineer. This requirement does not supersede the one-year warranty period on materials specified in Subsection 815.20.

The RRFB system shall be paid for at the contract unit price per Lump Sum. This shall include all labor, materials, equipment, and incidental costs required to complete the work.

METHOD OF MEASUREMENT

Item 824.201 shall be measured per LUMP SUM per location.

BASIS OF PAYMENT

Item 824.201 shall be paid at the contract unit price bid per LUMP SUM, per location, which payment shall be considered as full compensation for all labor, tools, equipment, materials, transportation, and incidental work required to complete the work.

Any existing signal equipment to be removed and discarded as part of this work shall be considered incidental to these items.

General Notes

1. Notes

Town of
ARLINGTON
Engineering Division
51 Grove Street
Arlington, MA 02476

RRFB Project Package SPECIFICATIONS

Project:	RRFB	Sheet:	5 of 5
Drawn By:	WAC		
Scale:	Not to Scale		
Date:	April 4, 2023		

RECTANGULAR RAPID FLASHING BEACON (RRFB)



MAURA HEALEY
Governor

KIM DRISCOLL
Lt. Governor

THE COMMONWEALTH OF MASSACHUSETTS
EXECUTIVE OFFICE OF LABOR AND WORKFORCE DEVELOPMENT
DEPARTMENT OF LABOR STANDARDS

Prevailing Wage Rates

As determined by the Director under the provisions of the
Massachusetts General Laws, Chapter 149, Sections 26 to 27H

LAUREN JONES
Secretary

MICHAEL FLANAGAN
Director

Awarding Authority: Town of Arlington
Contract Number: 23-27 **City/Town:** ARLINGTON
Description of Work: Installation of specified flashing beacon system at crosswalk location on Chestnut Street, Arlington MA to include solar power assembly connection.
Job Location: 17 Chestnut Street

Information about Prevailing Wage Schedules for Awarding Authorities and Contractors

- **The wage rates will remain in effect for the duration of the project, except in the case of multi-year public construction projects. For construction projects lasting longer than one year, awarding authorities must request an updated wage schedule no later than two weeks before the anniversary of the date the contract was executed by the awarding authority and the general contractor.** For multi-year CM AT RISK projects, the awarding authority must request an annual update no later than two weeks before the anniversary date, determined as the earlier of: (a) the execution date of the GMP Amendment, or (b) the execution date of the first amendment to permit procurement of construction services. The annual update requirement is not applicable to 27F "rental of equipment" contracts. **The updated wage schedule must be provided to all contractors, including general and sub-contractors, working on the construction project.**
- This wage schedule applies only to the specific project referenced at the top of this page and uniquely identified by the "Wage Request Number" on all pages of this schedule.
- An Awarding Authority must request an updated wage schedule if it has not opened bids or selected a contractor within 90 days of the date of issuance of the wage schedule. For CM AT RISK projects (bid pursuant to G.L. c.149A), the earlier of: (a) the execution date of the GMP Amendment, or (b) the bid for the first construction scope of work must be within 90-days of the wage schedule issuance date.
- The wage schedule shall be incorporated in any advertisement or call for bids for the project as required by M.G.L. c. 149, § 27. The wage schedule shall be made a part of the contract awarded for the project. The wage schedule must be posted in a conspicuous place at the work site for the life of the project in accordance with M.G.L. c. 149 § 27. The wages listed on the wage schedule must be paid to employees performing construction work on the project whether they are employed by the prime contractor, a filed sub-bidder, or a sub-contractor.
- Apprentices working on the project are required to be registered with the Massachusetts Division of Apprentice Standards (DAS). Apprentices must keep their apprentice identification card on their persons during all work hours on the project. An apprentice registered with DAS may be paid the lower apprentice wage rate at the applicable step as provided on the prevailing wage schedule. **Any apprentice not registered with DAS regardless of whether they are registered with another federal, state, local, or private agency must be paid the journeyworker's rate.**
- Every contractor or subcontractor working on the construction project must submit weekly payroll reports and a Statement of Compliance directly to the awarding authority by mail or email and keep them on file for three years. Each weekly payroll report must contain: the employee's name, address, occupational classification, hours worked, and wages paid. Do not submit weekly payroll reports to DLS. For a sample payroll reporting form go to <http://www.mass.gov/dols/pw>.
- Contractors with questions about the wage rates or classifications included on the wage schedule have an affirmative obligation to inquire with DLS at (617) 626-6953.
- Contractors must obtain the wage schedules from awarding authorities. Failure of a contractor or subcontractor to pay the prevailing wage rates listed on the wage schedule to all employees who perform construction work on the project is a violation of the law and subjects the contractor or subcontractor to civil and criminal penalties.
- Employees not receiving the prevailing wage rate set forth on the wage schedule may file a complaint with the Fair Labor Division of the office of the Attorney General at (617) 727-3465.

Classification	Effective Date	Base Wage	Health	Pension	Supplemental Unemployment	Total Rate
Construction						
(2 AXLE) DRIVER - EQUIPMENT <i>TEAMSTERS JOINT COUNCIL NO. 10 ZONE A</i>	12/01/2021	\$37.05	\$13.41	\$16.01	\$0.00	\$66.47
(3 AXLE) DRIVER - EQUIPMENT <i>TEAMSTERS JOINT COUNCIL NO. 10 ZONE A</i>	12/01/2021	\$37.12	\$13.41	\$16.01	\$0.00	\$66.54
(4 & 5 AXLE) DRIVER - EQUIPMENT <i>TEAMSTERS JOINT COUNCIL NO. 10 ZONE A</i>	12/01/2021	\$37.24	\$13.41	\$16.01	\$0.00	\$66.66
ADS/SUBMERSIBLE PILOT <i>PILE DRIVER LOCAL 56 (ZONE 1)</i>	08/01/2020	\$103.05	\$9.40	\$23.12	\$0.00	\$135.57
For apprentice rates see "Apprentice- PILE DRIVER"						
AIR TRACK OPERATOR <i>LABORERS - ZONE 1</i>	12/01/2022	\$43.93	\$9.10	\$17.57	\$0.00	\$70.60
	06/01/2023	\$44.93	\$9.10	\$17.57	\$0.00	\$71.60
	12/01/2023	\$46.18	\$9.10	\$17.57	\$0.00	\$72.85
For apprentice rates see "Apprentice- LABORER"						
AIR TRACK OPERATOR (HEAVY & HIGHWAY) <i>LABORERS - ZONE 1 (HEAVY & HIGHWAY)</i>	12/01/2022	\$43.33	\$9.35	\$17.82	\$0.00	\$70.50
	06/01/2023	\$44.33	\$9.35	\$17.82	\$0.00	\$71.50
	12/01/2023	\$45.58	\$9.35	\$17.82	\$0.00	\$72.75
	06/01/2024	\$47.06	\$9.35	\$17.82	\$0.00	\$74.23
	12/01/2024	\$48.53	\$9.35	\$17.82	\$0.00	\$75.70
	06/01/2025	\$50.03	\$9.35	\$17.82	\$0.00	\$77.20
	12/01/2025	\$51.53	\$9.35	\$17.82	\$0.00	\$78.70
	06/01/2026	\$53.08	\$9.35	\$17.82	\$0.00	\$80.25
	12/01/2026	\$54.58	\$9.35	\$17.82	\$0.00	\$81.75
For apprentice rates see "Apprentice- LABORER (Heavy and Highway)"						
ASBESTOS REMOVER - PIPE / MECH. EQUIPT. <i>HEAT & FROST INSULATORS LOCAL 6 (BOSTON)</i>	12/01/2020	\$38.10	\$12.80	\$9.45	\$0.00	\$60.35
ASPHALT RAKER <i>LABORERS - ZONE 1</i>	12/01/2022	\$43.43	\$9.10	\$17.57	\$0.00	\$70.10
	06/01/2023	\$44.43	\$9.10	\$17.57	\$0.00	\$71.10
	12/01/2023	\$45.68	\$9.10	\$17.57	\$0.00	\$72.35
For apprentice rates see "Apprentice- LABORER"						
ASPHALT RAKER (HEAVY & HIGHWAY) <i>LABORERS - ZONE 1 (HEAVY & HIGHWAY)</i>	12/01/2022	\$42.83	\$9.35	\$17.82	\$0.00	\$70.00
	06/01/2023	\$43.83	\$9.35	\$17.82	\$0.00	\$71.00
	12/01/2023	\$45.08	\$9.35	\$17.82	\$0.00	\$72.25
	06/01/2024	\$46.56	\$9.35	\$17.82	\$0.00	\$73.73
	12/01/2024	\$48.03	\$9.35	\$17.82	\$0.00	\$75.20
	06/01/2025	\$49.53	\$9.35	\$17.82	\$0.00	\$76.70
	12/01/2025	\$51.03	\$9.35	\$17.82	\$0.00	\$78.20
	06/01/2026	\$52.58	\$9.35	\$17.82	\$0.00	\$79.75
	12/01/2026	\$54.08	\$9.35	\$17.82	\$0.00	\$81.25
For apprentice rates see "Apprentice- LABORER (Heavy and Highway)"						

Classification	Effective Date	Base Wage	Health	Pension	Supplemental Unemployment	Total Rate
ASPHALT/CONCRETE/CRUSHER PLANT-ON SITE <i>OPERATING ENGINEERS LOCAL 4</i>	12/01/2022	\$53.63	\$14.25	\$16.05	\$0.00	\$83.93
	06/01/2023	\$54.88	\$14.25	\$16.05	\$0.00	\$85.18
	12/01/2023	\$56.13	\$14.25	\$16.05	\$0.00	\$86.43
	06/01/2024	\$57.43	\$14.25	\$16.05	\$0.00	\$87.73
	12/01/2024	\$58.88	\$14.25	\$16.05	\$0.00	\$89.18
	06/01/2025	\$60.18	\$14.25	\$16.05	\$0.00	\$90.48
	12/01/2025	\$61.63	\$14.25	\$16.05	\$0.00	\$91.93
	06/01/2026	\$62.93	\$14.25	\$16.05	\$0.00	\$93.23
	12/01/2026	\$64.38	\$14.25	\$16.05	\$0.00	\$94.68
For apprentice rates see "Apprentice- OPERATING ENGINEERS"						
BACKHOE/FRONT-END LOADER <i>OPERATING ENGINEERS LOCAL 4</i>	12/01/2022	\$53.63	\$14.25	\$16.05	\$0.00	\$83.93
	06/01/2023	\$54.88	\$14.25	\$16.05	\$0.00	\$85.18
	12/01/2023	\$56.13	\$14.25	\$16.05	\$0.00	\$86.43
	06/01/2024	\$57.43	\$14.25	\$16.05	\$0.00	\$87.73
	12/01/2024	\$58.88	\$14.25	\$16.05	\$0.00	\$89.18
	06/01/2025	\$60.18	\$14.25	\$16.05	\$0.00	\$90.48
	12/01/2025	\$61.63	\$14.25	\$16.05	\$0.00	\$91.93
	06/01/2026	\$62.93	\$14.25	\$16.05	\$0.00	\$93.23
	12/01/2026	\$64.38	\$14.25	\$16.05	\$0.00	\$94.68
For apprentice rates see "Apprentice- OPERATING ENGINEERS"						
BARCO-TYPE JUMPING TAMPER <i>LABORERS - ZONE 1</i>	12/01/2022	\$43.43	\$9.10	\$17.57	\$0.00	\$70.10
	06/01/2023	\$44.43	\$9.10	\$17.57	\$0.00	\$71.10
	12/01/2023	\$45.68	\$9.10	\$17.57	\$0.00	\$72.35
For apprentice rates see "Apprentice- LABORER"						
BLOCK PAVER, RAMMER / CURB SETTER <i>LABORERS - ZONE 1</i>	12/01/2022	\$43.93	\$9.10	\$17.57	\$0.00	\$70.60
	06/01/2023	\$44.93	\$9.10	\$17.57	\$0.00	\$71.60
	12/01/2023	\$46.18	\$9.10	\$17.57	\$0.00	\$72.85
For apprentice rates see "Apprentice- LABORER"						
BLOCK PAVER, RAMMER / CURB SETTER (HEAVY & HIGHWAY) <i>LABORERS - ZONE 1 (HEAVY & HIGHWAY)</i>	12/01/2022	\$43.33	\$9.35	\$17.82	\$0.00	\$70.50
	06/01/2023	\$44.33	\$9.35	\$17.82	\$0.00	\$71.50
	12/01/2023	\$45.58	\$9.35	\$17.82	\$0.00	\$72.75
	06/01/2024	\$47.06	\$9.35	\$17.82	\$0.00	\$74.23
	12/01/2024	\$48.53	\$9.35	\$17.82	\$0.00	\$75.70
	06/01/2025	\$50.03	\$9.35	\$17.82	\$0.00	\$77.20
	12/01/2025	\$51.53	\$9.35	\$17.82	\$0.00	\$78.70
	06/01/2026	\$53.08	\$9.35	\$17.82	\$0.00	\$80.25
	12/01/2026	\$54.58	\$9.35	\$17.82	\$0.00	\$81.75
For apprentice rates see "Apprentice- LABORER (Heavy and Highway)"						
BOILER MAKER <i>BOILERMAKERS LOCAL 29</i>	01/01/2023	\$47.37	\$7.07	\$20.31	\$0.00	\$74.75
	01/01/2024	\$48.12	\$7.07	\$20.60	\$0.00	\$75.79

Classification

Effective Date Base Wage Health Pension Supplemental Unemployment Total Rate

Apprentice - BOILERMAKER - Local 29

Effective Date - 01/01/2023

Step	percent	Apprentice Base Wage	Health	Pension	Supplemental Unemployment	Total Rate
1	65	\$30.79	\$7.07	\$13.22	\$0.00	\$51.08
2	65	\$30.79	\$7.07	\$13.22	\$0.00	\$51.08
3	70	\$33.16	\$7.07	\$14.23	\$0.00	\$54.46
4	75	\$35.53	\$7.07	\$15.24	\$0.00	\$57.84
5	80	\$37.90	\$7.07	\$16.25	\$0.00	\$61.22
6	85	\$40.26	\$7.07	\$17.28	\$0.00	\$64.61
7	90	\$42.63	\$7.07	\$18.28	\$0.00	\$67.98
8	95	\$45.00	\$7.07	\$19.32	\$0.00	\$71.39

Effective Date - 01/01/2024

Step	percent	Apprentice Base Wage	Health	Pension	Supplemental Unemployment	Total Rate
1	65	\$31.28	\$7.07	\$13.22	\$0.00	\$51.57
2	65	\$31.28	\$7.07	\$13.22	\$0.00	\$51.57
3	70	\$33.68	\$7.07	\$14.23	\$0.00	\$54.98
4	75	\$36.09	\$7.07	\$15.24	\$0.00	\$58.40
5	80	\$38.50	\$7.07	\$16.25	\$0.00	\$61.82
6	85	\$40.90	\$7.07	\$17.28	\$0.00	\$65.25
7	90	\$43.31	\$7.07	\$18.28	\$0.00	\$68.66
8	95	\$45.71	\$7.07	\$19.32	\$0.00	\$72.10

Notes:

Apprentice to Journeyworker Ratio:1:4

BRICK/STONE/ARTIFICIAL MASONRY (INCL. MASONRY WATERPROOFING)	02/01/2023	\$60.35	\$11.49	\$22.34	\$0.00	\$94.18
BRICKLAYERS LOCAL 3 (BOSTON)	08/01/2023	\$62.40	\$11.49	\$22.34	\$0.00	\$96.23
	02/01/2024	\$63.65	\$11.49	\$22.34	\$0.00	\$97.48
	08/01/2024	\$65.75	\$11.49	\$22.34	\$0.00	\$99.58
	02/01/2025	\$67.05	\$11.49	\$22.34	\$0.00	\$100.88
	08/01/2025	\$69.20	\$11.49	\$22.34	\$0.00	\$103.03
	02/01/2026	\$70.55	\$11.49	\$22.34	\$0.00	\$104.38
	08/01/2026	\$72.75	\$11.49	\$22.34	\$0.00	\$106.58
	02/01/2027	\$74.15	\$11.49	\$22.34	\$0.00	\$107.98

Classification

Effective Date Base Wage Health Pension Supplemental Unemployment Total Rate

Apprentice - BRICK/PLASTER/CEMENT MASON - Local 3 Boston

Effective Date - 02/01/2023

Step	percent	Apprentice Base Wage	Health	Pension	Supplemental Unemployment	Total Rate
1	50	\$30.18	\$11.49	\$22.34	\$0.00	\$64.01
2	60	\$36.21	\$11.49	\$22.34	\$0.00	\$70.04
3	70	\$42.25	\$11.49	\$22.34	\$0.00	\$76.08
4	80	\$48.28	\$11.49	\$22.34	\$0.00	\$82.11
5	90	\$54.32	\$11.49	\$22.34	\$0.00	\$88.15

Effective Date - 08/01/2023

Step	percent	Apprentice Base Wage	Health	Pension	Supplemental Unemployment	Total Rate
1	50	\$31.20	\$11.49	\$22.34	\$0.00	\$65.03
2	60	\$37.44	\$11.49	\$22.34	\$0.00	\$71.27
3	70	\$43.68	\$11.49	\$22.34	\$0.00	\$77.51
4	80	\$49.92	\$11.49	\$22.34	\$0.00	\$83.75
5	90	\$56.16	\$11.49	\$22.34	\$0.00	\$89.99

Notes:

Apprentice to Journeyworker Ratio:1:5

BULLDOZER/GRADER/SCRAPER	12/01/2022	\$53.05	\$14.25	\$16.05	\$0.00	\$83.35
<i>OPERATING ENGINEERS LOCAL 4</i>	06/01/2023	\$54.29	\$14.25	\$16.05	\$0.00	\$84.59
	12/01/2023	\$55.53	\$14.25	\$16.05	\$0.00	\$85.83
	06/01/2024	\$56.81	\$14.25	\$16.05	\$0.00	\$87.11
	12/01/2024	\$58.25	\$14.25	\$16.05	\$0.00	\$88.55
	06/01/2025	\$59.53	\$14.25	\$16.05	\$0.00	\$89.83
	12/01/2025	\$60.97	\$14.25	\$16.05	\$0.00	\$91.27
	06/01/2026	\$62.25	\$14.25	\$16.05	\$0.00	\$92.55
	12/01/2026	\$63.69	\$14.25	\$16.05	\$0.00	\$93.99

For apprentice rates see "Apprentice- OPERATING ENGINEERS"

CAISSON & UNDERPINNING BOTTOM MAN	12/01/2022	\$43.73	\$9.35	\$17.97	\$0.00	\$71.05
<i>LABORERS - FOUNDATION AND MARINE</i>	06/01/2023	\$44.73	\$9.35	\$17.97	\$0.00	\$72.05
	12/01/2023	\$45.98	\$9.35	\$17.97	\$0.00	\$73.30
	06/01/2024	\$47.46	\$9.35	\$17.97	\$0.00	\$74.78
	12/01/2024	\$48.93	\$9.35	\$17.97	\$0.00	\$76.25
	06/01/2025	\$50.43	\$9.35	\$17.97	\$0.00	\$77.75
	12/01/2025	\$51.93	\$9.35	\$17.97	\$0.00	\$79.25
	06/01/2026	\$53.48	\$9.35	\$17.97	\$0.00	\$80.80
	12/01/2026	\$54.98	\$9.35	\$17.97	\$0.00	\$82.30

For apprentice rates see "Apprentice- LABORER"

Classification	Effective Date	Base Wage	Health	Pension	Supplemental Unemployment	Total Rate
CAISSON & UNDERPINNING LABORER <i>LABORERS - FOUNDATION AND MARINE</i>	12/01/2022	\$42.58	\$9.35	\$17.97	\$0.00	\$69.90
	06/01/2023	\$43.58	\$9.35	\$17.97	\$0.00	\$70.90
	12/01/2023	\$44.83	\$9.35	\$17.97	\$0.00	\$72.15
	06/01/2024	\$46.31	\$9.35	\$17.97	\$0.00	\$73.63
	12/01/2024	\$47.78	\$9.35	\$17.97	\$0.00	\$75.10
	06/01/2025	\$49.28	\$9.35	\$17.97	\$0.00	\$76.60
	12/01/2025	\$50.78	\$9.35	\$17.97	\$0.00	\$78.10
	06/01/2026	\$52.33	\$9.35	\$17.97	\$0.00	\$79.65
	12/01/2026	\$53.83	\$9.35	\$17.97	\$0.00	\$81.15
For apprentice rates see "Apprentice- LABORER"						
CAISSON & UNDERPINNING TOP MAN <i>LABORERS - FOUNDATION AND MARINE</i>	12/01/2022	\$42.58	\$9.35	\$17.97	\$0.00	\$69.90
	06/01/2023	\$43.58	\$9.35	\$17.97	\$0.00	\$70.90
	12/01/2023	\$44.83	\$9.35	\$17.97	\$0.00	\$72.15
	06/01/2024	\$46.31	\$9.35	\$17.97	\$0.00	\$73.63
	12/01/2024	\$47.78	\$9.35	\$17.97	\$0.00	\$75.10
	06/01/2025	\$49.28	\$9.35	\$17.97	\$0.00	\$76.60
	12/01/2025	\$50.78	\$9.35	\$17.97	\$0.00	\$78.10
	06/01/2026	\$52.33	\$9.35	\$17.97	\$0.00	\$79.65
	12/01/2026	\$53.83	\$9.35	\$17.97	\$0.00	\$81.15
For apprentice rates see "Apprentice- LABORER"						
CARBIDE CORE DRILL OPERATOR <i>LABORERS - ZONE 1</i>	12/01/2022	\$43.43	\$9.10	\$17.57	\$0.00	\$70.10
	06/01/2023	\$44.43	\$9.10	\$17.57	\$0.00	\$71.10
	12/01/2023	\$45.68	\$9.10	\$17.57	\$0.00	\$72.35
For apprentice rates see "Apprentice- LABORER"						
CARPENTER <i>CARPENTERS -ZONE 2 (Eastern Massachusetts)</i>	03/01/2023	\$45.78	\$8.68	\$19.97	\$0.00	\$74.43

Apprentice - CARPENTER - Zone 2 Eastern MA

Effective Date - 03/01/2023

Step	percent	Apprentice Base Wage	Health	Pension	Supplemental Unemployment	Total Rate
1	50	\$22.89	\$8.68	\$1.73	\$0.00	\$33.30
2	60	\$27.47	\$8.68	\$1.73	\$0.00	\$37.88
3	70	\$32.05	\$8.68	\$14.78	\$0.00	\$55.51
4	75	\$34.34	\$8.68	\$14.78	\$0.00	\$57.80
5	80	\$36.62	\$8.68	\$16.51	\$0.00	\$61.81
6	80	\$36.62	\$8.68	\$16.51	\$0.00	\$61.81
7	90	\$41.20	\$8.68	\$18.24	\$0.00	\$68.12
8	90	\$41.20	\$8.68	\$18.24	\$0.00	\$68.12

Notes:

% Indentured After 10/1/17; 45/45/55/55/70/70/80/80
Step 1&2 \$30.71/ 3&4 \$36.93/ 5&6 \$56.82/ 7&8 \$63.06

Apprentice to Journeyworker Ratio:1:5

CARPENTER WOOD FRAME <i>CARPENTERS-ZONE 3 (Wood Frame)</i>	04/01/2022	\$23.66	\$7.21	\$4.80	\$0.00	\$35.67
	04/01/2023	\$24.16	\$7.21	\$4.80	\$0.00	\$36.17

All Aspects of New Wood Frame Work

Classification

Effective Date Base Wage Health Pension Supplemental Unemployment Total Rate

Apprentice - CARPENTER (Wood Frame) - Zone 3

Effective Date - 04/01/2022

Step	percent	Apprentice Base Wage	Health	Pension	Supplemental Unemployment	Total Rate
1	60	\$14.20	\$7.21	\$0.00	\$0.00	\$21.41
2	60	\$14.20	\$7.21	\$0.00	\$0.00	\$21.41
3	65	\$15.38	\$7.21	\$0.00	\$0.00	\$22.59
4	70	\$16.56	\$7.21	\$0.00	\$0.00	\$23.77
5	75	\$17.75	\$7.21	\$3.80	\$0.00	\$28.76
6	80	\$18.93	\$7.21	\$3.80	\$0.00	\$29.94
7	85	\$20.11	\$7.21	\$3.80	\$0.00	\$31.12
8	90	\$21.29	\$7.21	\$3.80	\$0.00	\$32.30

Effective Date - 04/01/2023

Step	percent	Apprentice Base Wage	Health	Pension	Supplemental Unemployment	Total Rate
1	60	\$14.50	\$7.21	\$0.00	\$0.00	\$21.71
2	60	\$14.50	\$7.21	\$0.00	\$0.00	\$21.71
3	65	\$15.70	\$7.21	\$0.00	\$0.00	\$22.91
4	70	\$16.91	\$7.21	\$0.00	\$0.00	\$24.12
5	75	\$18.12	\$7.21	\$3.80	\$0.00	\$29.13
6	80	\$19.33	\$7.21	\$3.80	\$0.00	\$30.34
7	85	\$20.54	\$7.21	\$3.80	\$0.00	\$31.55
8	90	\$21.74	\$7.21	\$3.80	\$0.00	\$32.75

Notes:

% Indentured After 10/1/17; 45/45/55/55/70/70/80/80
 Step 1&2 \$17.86/ 3&4 \$20.22/ 5&6 \$27.57/ 7&8 \$29.94

Apprentice to Journeyworker Ratio:1:5

CEMENT MASONRY/PLASTERING	01/01/2023	\$49.45	\$12.75	\$22.74	\$0.87	\$85.81
BRICKLAYERS LOCAL 3 (BOSTON)	07/01/2023	\$50.59	\$12.75	\$22.74	\$0.87	\$86.95
	01/01/2024	\$51.73	\$12.75	\$22.74	\$0.87	\$88.09

Classification

Effective Date Base Wage Health Pension Supplemental Unemployment Total Rate

Apprentice - CEMENT MASONRY/PLASTERING - Eastern Mass (Boston)

Effective Date - 01/01/2023

Step	percent	Apprentice Base Wage	Health	Pension	Supplemental Unemployment	Total Rate
1	50	\$24.73	\$12.75	\$15.49	\$0.00	\$52.97
2	60	\$29.67	\$12.75	\$22.74	\$0.87	\$66.03
3	65	\$32.14	\$12.75	\$22.74	\$0.87	\$68.50
4	70	\$34.62	\$12.75	\$22.74	\$0.87	\$70.98
5	75	\$37.09	\$12.75	\$22.74	\$0.87	\$73.45
6	80	\$39.56	\$12.75	\$22.74	\$0.87	\$75.92
7	90	\$44.51	\$12.75	\$22.74	\$0.87	\$80.87

Effective Date - 07/01/2023

Step	percent	Apprentice Base Wage	Health	Pension	Supplemental Unemployment	Total Rate
1	50	\$25.30	\$12.75	\$15.49	\$0.00	\$53.54
2	60	\$30.35	\$12.75	\$22.74	\$0.87	\$66.71
3	65	\$32.88	\$12.75	\$22.74	\$0.87	\$69.24
4	70	\$35.41	\$12.75	\$22.74	\$0.87	\$71.77
5	75	\$37.94	\$12.75	\$22.74	\$0.87	\$74.30
6	80	\$40.47	\$12.75	\$22.74	\$0.87	\$76.83
7	90	\$45.53	\$12.75	\$22.74	\$0.87	\$81.89

Notes:
Steps 3,4 are 500 hrs. All other steps are 1,000 hrs.

Apprentice to Journeyworker Ratio:1:3

CHAIN SAW OPERATOR LABORERS - ZONE 1	12/01/2022	\$43.43	\$9.10	\$17.57	\$0.00	\$70.10
	06/01/2023	\$44.43	\$9.10	\$17.57	\$0.00	\$71.10
	12/01/2023	\$45.68	\$9.10	\$17.57	\$0.00	\$72.35

For apprentice rates see "Apprentice- LABORER"

CLAM SHELLS/SLURRY BUCKETS/HEADING MACHINES OPERATING ENGINEERS LOCAL 4	12/01/2022	\$54.68	\$14.25	\$16.05	\$0.00	\$84.98
	06/01/2023	\$55.95	\$14.25	\$16.05	\$0.00	\$86.25
	12/01/2023	\$57.23	\$14.25	\$16.05	\$0.00	\$87.53
	06/01/2024	\$58.55	\$14.25	\$16.05	\$0.00	\$88.85
	12/01/2024	\$60.03	\$14.25	\$16.05	\$0.00	\$90.33
	06/01/2025	\$61.36	\$14.25	\$16.05	\$0.00	\$91.66
	12/01/2025	\$62.83	\$14.25	\$16.05	\$0.00	\$93.13
	06/01/2026	\$64.16	\$14.25	\$16.05	\$0.00	\$94.46
	12/01/2026	\$65.64	\$14.25	\$16.05	\$0.00	\$95.94

For apprentice rates see "Apprentice- OPERATING ENGINEERS"

Classification	Effective Date	Base Wage	Health	Pension	Supplemental Unemployment	Total Rate
COMPRESSOR OPERATOR <i>OPERATING ENGINEERS LOCAL 4</i>	12/01/2022	\$35.08	\$14.25	\$16.05	\$0.00	\$65.38
	06/01/2023	\$35.90	\$14.25	\$16.05	\$0.00	\$66.20
	12/01/2023	\$36.72	\$14.25	\$16.05	\$0.00	\$67.02
	06/01/2024	\$37.57	\$14.25	\$16.05	\$0.00	\$67.87
	12/01/2024	\$38.52	\$14.25	\$16.05	\$0.00	\$68.82
	06/01/2025	\$39.37	\$14.25	\$16.05	\$0.00	\$69.67
	12/01/2025	\$40.32	\$14.25	\$16.05	\$0.00	\$70.62
	06/01/2026	\$41.18	\$14.25	\$16.05	\$0.00	\$71.48
	12/01/2026	\$42.13	\$14.25	\$16.05	\$0.00	\$72.43

For apprentice rates see "Apprentice- OPERATING ENGINEERS"

DELEADER (BRIDGE) <i>PAINTERS LOCAL 35 - ZONE 2</i>	01/01/2023	\$56.06	\$8.65	\$23.05	\$0.00	\$87.76
	07/01/2023	\$57.26	\$8.65	\$23.05	\$0.00	\$88.96
	01/01/2024	\$58.46	\$8.65	\$23.05	\$0.00	\$90.16
	07/01/2024	\$59.66	\$8.65	\$23.05	\$0.00	\$91.36
	01/01/2025	\$60.86	\$8.65	\$23.05	\$0.00	\$92.56

Apprentice - PAINTER Local 35 - BRIDGES/TANKS

Effective Date - 01/01/2023

Step	percent	Apprentice Base Wage	Health	Pension	Supplemental Unemployment	Total Rate
1	50	\$28.03	\$8.65	\$0.00	\$0.00	\$36.68
2	55	\$30.83	\$8.65	\$6.27	\$0.00	\$45.75
3	60	\$33.64	\$8.65	\$6.84	\$0.00	\$49.13
4	65	\$36.44	\$8.65	\$7.41	\$0.00	\$52.50
5	70	\$39.24	\$8.65	\$19.63	\$0.00	\$67.52
6	75	\$42.05	\$8.65	\$20.20	\$0.00	\$70.90
7	80	\$44.85	\$8.65	\$20.77	\$0.00	\$74.27
8	90	\$50.45	\$8.65	\$21.91	\$0.00	\$81.01

Effective Date - 07/01/2023

Step	percent	Apprentice Base Wage	Health	Pension	Supplemental Unemployment	Total Rate
1	50	\$28.63	\$8.65	\$0.00	\$0.00	\$37.28
2	55	\$31.49	\$8.65	\$6.27	\$0.00	\$46.41
3	60	\$34.36	\$8.65	\$6.84	\$0.00	\$49.85
4	65	\$37.22	\$8.65	\$7.41	\$0.00	\$53.28
5	70	\$40.08	\$8.65	\$19.63	\$0.00	\$68.36
6	75	\$42.95	\$8.65	\$20.20	\$0.00	\$71.80
7	80	\$45.81	\$8.65	\$20.77	\$0.00	\$75.23
8	90	\$51.53	\$8.65	\$21.91	\$0.00	\$82.09

Notes:

Steps are 750 hrs.

Apprentice to Journeyworker Ratio:1:1

DEMO: ADZEMAN <i>LABORERS - ZONE 1</i>	12/01/2022	\$43.33	\$9.10	\$17.57	\$0.00	\$70.00
	06/01/2023	\$44.33	\$9.10	\$17.57	\$0.00	\$71.00
	12/01/2023	\$45.58	\$9.10	\$17.57	\$0.00	\$72.25

Classification	Effective Date	Base Wage	Health	Pension	Supplemental Unemployment	Total Rate
For apprentice rates see "Apprentice- LABORER"						
DEMO: BACKHOE/LOADER/HAMMER OPERATOR <i>LABORERS - ZONE 1</i>	12/01/2022	\$44.33	\$9.10	\$17.57	\$0.00	\$71.00
	06/01/2023	\$45.33	\$9.10	\$17.57	\$0.00	\$72.00
	12/01/2023	\$46.58	\$9.10	\$17.57	\$0.00	\$73.25
For apprentice rates see "Apprentice- LABORER"						
DEMO: BURNERS <i>LABORERS - ZONE 1</i>	12/01/2022	\$44.08	\$9.10	\$17.57	\$0.00	\$70.75
	06/01/2023	\$45.08	\$9.10	\$17.57	\$0.00	\$71.75
	12/01/2023	\$46.33	\$9.10	\$17.57	\$0.00	\$73.00
For apprentice rates see "Apprentice- LABORER"						
DEMO: CONCRETE CUTTER/SAWYER <i>LABORERS - ZONE 1</i>	12/01/2022	\$44.33	\$9.10	\$17.57	\$0.00	\$71.00
	06/01/2023	\$45.33	\$9.10	\$17.57	\$0.00	\$72.00
	12/01/2023	\$46.58	\$9.10	\$17.57	\$0.00	\$73.25
For apprentice rates see "Apprentice- LABORER"						
DEMO: JACKHAMMER OPERATOR <i>LABORERS - ZONE 1</i>	12/01/2022	\$44.08	\$9.10	\$17.57	\$0.00	\$70.75
	06/01/2023	\$45.08	\$9.10	\$17.57	\$0.00	\$71.75
	12/01/2023	\$46.33	\$9.10	\$17.57	\$0.00	\$73.00
For apprentice rates see "Apprentice- LABORER"						
DEMO: WRECKING LABORER <i>LABORERS - ZONE 1</i>	12/01/2022	\$43.33	\$9.10	\$17.57	\$0.00	\$70.00
	06/01/2023	\$44.33	\$9.10	\$17.57	\$0.00	\$71.00
	12/01/2023	\$45.58	\$9.10	\$17.57	\$0.00	\$72.25
For apprentice rates see "Apprentice- LABORER"						
DIRECTIONAL DRILL MACHINE OPERATOR <i>OPERATING ENGINEERS LOCAL 4</i>	12/01/2022	\$53.05	\$14.25	\$16.05	\$0.00	\$83.35
	06/01/2023	\$54.29	\$14.25	\$16.05	\$0.00	\$84.59
	12/01/2023	\$55.53	\$14.25	\$16.05	\$0.00	\$85.83
	06/01/2024	\$56.81	\$14.25	\$16.05	\$0.00	\$87.11
	12/01/2024	\$58.25	\$14.25	\$16.05	\$0.00	\$88.55
	06/01/2025	\$59.53	\$14.25	\$16.05	\$0.00	\$89.83
	12/01/2025	\$60.97	\$14.25	\$16.05	\$0.00	\$91.27
	06/01/2026	\$62.25	\$14.25	\$16.05	\$0.00	\$92.55
	12/01/2026	\$63.69	\$14.25	\$16.05	\$0.00	\$93.99
For apprentice rates see "Apprentice- OPERATING ENGINEERS"						
DIVER <i>PILE DRIVER LOCAL 56 (ZONE 1)</i>	08/01/2020	\$68.70	\$9.40	\$23.12	\$0.00	\$101.22
For apprentice rates see "Apprentice- PILE DRIVER"						
DIVER TENDER <i>PILE DRIVER LOCAL 56 (ZONE 1)</i>	08/01/2020	\$49.07	\$9.40	\$23.12	\$0.00	\$81.59
For apprentice rates see "Apprentice- PILE DRIVER"						
DIVER TENDER (EFFLUENT) <i>PILE DRIVER LOCAL 56 (ZONE 1)</i>	08/01/2020	\$73.60	\$9.40	\$23.12	\$0.00	\$106.12
For apprentice rates see "Apprentice- PILE DRIVER"						
DIVER/SLURRY (EFFLUENT) <i>PILE DRIVER LOCAL 56 (ZONE 1)</i>	08/01/2020	\$103.05	\$9.40	\$23.12	\$0.00	\$135.57
For apprentice rates see "Apprentice- PILE DRIVER"						
DRAWBRIDGE OPERATOR (Construction) <i>DRAWBRIDGE - SEIU LOCAL 888</i>	07/01/2020	\$26.77	\$6.67	\$3.93	\$0.16	\$37.53
ELECTRICIAN <i>ELECTRICIANS LOCAL 103</i>	03/01/2023	\$59.23	\$13.00	\$21.63	\$0.00	\$93.86

Classification

Effective Date Base Wage Health Pension Supplemental Unemployment Total Rate

Apprentice - ELECTRICIAN - Local 103

Effective Date - 03/01/2023

Step	percent	Apprentice Base Wage	Health	Pension	Supplemental Unemployment	Total Rate
1	40	\$23.69	\$13.00	\$0.71	\$0.00	\$37.40
2	40	\$23.69	\$13.00	\$0.71	\$0.00	\$37.40
3	45	\$26.65	\$13.00	\$16.13	\$0.00	\$55.78
4	45	\$26.65	\$13.00	\$16.13	\$0.00	\$55.78
5	50	\$29.62	\$13.00	\$16.63	\$0.00	\$59.25
6	55	\$32.58	\$13.00	\$17.13	\$0.00	\$62.71
7	60	\$35.54	\$13.00	\$17.63	\$0.00	\$66.17
8	65	\$38.50	\$13.00	\$18.13	\$0.00	\$69.63
9	70	\$41.46	\$13.00	\$18.62	\$0.00	\$73.08
10	75	\$44.42	\$13.00	\$19.13	\$0.00	\$76.55

Notes:
App Prior 1/1/03; 30/35/40/45/50/55/65/70/75/80

Apprentice to Journeyworker Ratio:2:3***

ELEVATOR CONSTRUCTOR ELEVATOR CONSTRUCTORS LOCAL 4	01/01/2022	\$65.62	\$16.03	\$20.21	\$0.00	\$101.86
---	------------	---------	---------	---------	--------	----------

Apprentice - ELEVATOR CONSTRUCTOR - Local 4

Effective Date - 01/01/2022

Step	percent	Apprentice Base Wage	Health	Pension	Supplemental Unemployment	Total Rate
1	50	\$32.81	\$16.03	\$0.00	\$0.00	\$48.84
2	55	\$36.09	\$16.03	\$20.21	\$0.00	\$72.33
3	65	\$42.65	\$16.03	\$20.21	\$0.00	\$78.89
4	70	\$45.93	\$16.03	\$20.21	\$0.00	\$82.17
5	80	\$52.50	\$16.03	\$20.21	\$0.00	\$88.74

Notes:
Steps 1-2 are 6 mos.; Steps 3-5 are 1 year

Apprentice to Journeyworker Ratio:1:1

ELEVATOR CONSTRUCTOR HELPER ELEVATOR CONSTRUCTORS LOCAL 4	01/01/2022	\$45.93	\$16.03	\$20.21	\$0.00	\$82.17
--	------------	---------	---------	---------	--------	---------

For apprentice rates see "Apprentice - ELEVATOR CONSTRUCTOR"

Classification	Effective Date	Base Wage	Health	Pension	Supplemental Unemployment	Total Rate
FENCE & GUARD RAIL ERECTOR (HEAVY & HIGHWAY) <i>LABORERS - ZONE 1 (HEAVY & HIGHWAY)</i>	12/01/2022	\$42.83	\$9.35	\$17.82	\$0.00	\$70.00
	06/01/2023	\$43.83	\$9.35	\$17.82	\$0.00	\$71.00
	12/01/2023	\$45.08	\$9.35	\$17.82	\$0.00	\$72.25
	06/01/2024	\$46.56	\$9.35	\$17.82	\$0.00	\$73.73
	12/01/2024	\$48.03	\$9.35	\$17.82	\$0.00	\$75.20
	06/01/2025	\$49.53	\$9.35	\$17.82	\$0.00	\$76.70
	12/01/2025	\$51.03	\$9.35	\$17.82	\$0.00	\$78.20
	06/01/2026	\$52.58	\$9.35	\$17.82	\$0.00	\$79.75
	12/01/2026	\$54.08	\$9.35	\$17.82	\$0.00	\$81.25
For apprentice rates see "Apprentice- LABORER (Heavy and Highway)						
FIELD ENG.INST.PERSON-BLDG,SITE,HVY/HWY <i>OPERATING ENGINEERS LOCAL 4</i>	11/05/2022	\$48.67	\$14.25	\$16.05	\$0.00	\$78.97
	05/01/2023	\$49.91	\$14.25	\$16.05	\$0.00	\$80.21
	11/01/2023	\$51.15	\$14.25	\$16.05	\$0.00	\$81.45
	05/01/2024	\$52.39	\$14.25	\$16.05	\$0.00	\$82.69
	11/01/2024	\$53.68	\$14.25	\$16.05	\$0.00	\$83.98
	05/01/2025	\$55.12	\$14.25	\$16.05	\$0.00	\$85.42
	11/01/2025	\$56.41	\$14.25	\$16.05	\$0.00	\$86.71
	05/01/2026	\$57.85	\$14.25	\$16.05	\$0.00	\$88.15
	11/01/2026	\$59.14	\$14.25	\$16.05	\$0.00	\$89.44
05/01/2027	\$60.57	\$14.25	\$16.05	\$0.00	\$90.87	
For apprentice rates see "Apprentice- OPERATING ENGINEERS"						
FIELD ENG.PARTY CHIEF-BLDG,SITE,HVY/HWY <i>OPERATING ENGINEERS LOCAL 4</i>	11/01/2022	\$50.22	\$14.25	\$16.05	\$0.00	\$80.52
	05/01/2023	\$51.47	\$14.25	\$16.05	\$0.00	\$81.77
	11/01/2023	\$52.72	\$14.25	\$16.05	\$0.00	\$83.02
	05/01/2024	\$53.97	\$14.25	\$16.05	\$0.00	\$84.27
	11/01/2024	\$55.27	\$14.25	\$16.05	\$0.00	\$85.57
	05/01/2025	\$56.72	\$14.25	\$16.05	\$0.00	\$87.02
	11/01/2025	\$58.02	\$14.25	\$16.05	\$0.00	\$88.32
	05/01/2026	\$59.47	\$14.25	\$16.05	\$0.00	\$89.77
	11/01/2026	\$60.77	\$14.25	\$16.05	\$0.00	\$91.07
05/01/2027	\$62.22	\$14.25	\$16.05	\$0.00	\$92.52	
For apprentice rates see "Apprentice- OPERATING ENGINEERS"						
FIELD ENG.ROD PERSON-BLDG,SITE,HVY/HWY <i>OPERATING ENGINEERS LOCAL 4</i>	11/01/2022	\$24.31	\$14.25	\$16.05	\$0.00	\$54.61
	05/01/2023	\$25.05	\$14.25	\$16.05	\$0.00	\$55.35
	11/01/2023	\$25.78	\$14.25	\$16.05	\$0.00	\$56.08
	05/01/2024	\$26.51	\$14.25	\$16.05	\$0.00	\$56.81
	11/01/2024	\$27.27	\$14.25	\$16.05	\$0.00	\$57.57
	05/01/2025	\$28.12	\$14.25	\$16.05	\$0.00	\$58.42
	11/01/2025	\$28.88	\$14.25	\$16.05	\$0.00	\$59.18
	05/01/2026	\$29.73	\$14.25	\$16.05	\$0.00	\$60.03
	11/01/2026	\$30.49	\$14.25	\$16.05	\$0.00	\$60.79
05/01/2027	\$31.34	\$14.25	\$16.05	\$0.00	\$61.64	
For apprentice rates see "Apprentice- OPERATING ENGINEERS"						
FIRE ALARM INSTALLER <i>ELECTRICIANS LOCAL 103</i>	03/01/2023	\$59.23	\$13.00	\$21.63	\$0.00	\$93.86
For apprentice rates see "Apprentice- ELECTRICIAN"						

Classification	Effective Date	Base Wage	Health	Pension	Supplemental Unemployment	Total Rate
FIRE ALARM REPAIR / MAINTENANCE / COMMISSIONING <i>ELECTRICIANS</i>	03/01/2023	\$48.34	\$13.00	\$19.01	\$0.00	\$80.35
<i>LOCAL 103</i> For apprentice rates see "Apprentice- TELECOMMUNICATIONS TECHNICIAN"						
FIREMAN (ASST. ENGINEER) <i>OPERATING ENGINEERS LOCAL 4</i>	12/01/2022	\$43.54	\$14.25	\$16.05	\$0.00	\$73.84
	06/01/2023	\$44.56	\$14.25	\$16.05	\$0.00	\$74.86
	12/01/2023	\$45.57	\$14.25	\$16.05	\$0.00	\$75.87
	06/01/2024	\$46.63	\$14.25	\$16.05	\$0.00	\$76.93
	12/01/2024	\$47.81	\$14.25	\$16.05	\$0.00	\$78.11
	06/01/2025	\$48.87	\$14.25	\$16.05	\$0.00	\$79.17
	12/01/2025	\$50.04	\$14.25	\$16.05	\$0.00	\$80.34
	06/01/2026	\$51.10	\$14.25	\$16.05	\$0.00	\$81.40
	12/01/2026	\$52.28	\$14.25	\$16.05	\$0.00	\$82.58
For apprentice rates see "Apprentice- OPERATING ENGINEERS"						
FLAGGER & SIGNALER (HEAVY & HIGHWAY) <i>LABORERS - ZONE 1 (HEAVY & HIGHWAY)</i>	12/01/2022	\$25.23	\$9.35	\$17.82	\$0.00	\$52.40
	06/01/2023	\$25.98	\$9.35	\$17.82	\$0.00	\$53.15
	12/01/2023	\$25.98	\$9.35	\$17.82	\$0.00	\$53.15
	06/01/2024	\$27.01	\$9.35	\$17.82	\$0.00	\$54.18
	12/01/2024	\$27.01	\$9.35	\$17.82	\$0.00	\$54.18
	06/01/2025	\$28.09	\$9.35	\$17.82	\$0.00	\$55.26
	12/01/2025	\$28.09	\$9.35	\$17.82	\$0.00	\$55.26
	06/01/2026	\$29.21	\$9.35	\$17.82	\$0.00	\$56.38
	12/01/2026	\$29.21	\$9.35	\$17.82	\$0.00	\$56.38
For apprentice rates see "Apprentice- LABORER (Heavy and Highway)"						
FLOORCOVERER <i>FLOORCOVERERS LOCAL 2168 ZONE 1</i>	03/01/2022	\$49.93	\$8.68	\$20.27	\$0.00	\$78.88

Apprentice - FLOORCOVERER - Local 2168 Zone 1

Effective Date - 03/01/2022

Step	percent	Apprentice Base Wage	Health	Pension	Supplemental Unemployment	Total Rate
1	50	\$24.97	\$8.68	\$1.79	\$0.00	\$35.44
2	55	\$27.46	\$8.68	\$1.79	\$0.00	\$37.93
3	60	\$29.96	\$8.68	\$14.90	\$0.00	\$53.54
4	65	\$32.45	\$8.68	\$14.90	\$0.00	\$56.03
5	70	\$34.95	\$8.68	\$16.69	\$0.00	\$60.32
6	75	\$37.45	\$8.68	\$16.69	\$0.00	\$62.82
7	80	\$39.94	\$8.68	\$18.48	\$0.00	\$67.10
8	85	\$42.44	\$8.68	\$18.48	\$0.00	\$69.60

Notes: Steps are 750 hrs.
% After 10/1/17; 45/45/55/55/70/70/80/80 (1500hr Steps)
Step 1&2 \$32.94/ 3&4 \$39.66/ 5&6 \$60.32/ 7&8 \$67.10

Apprentice to Journeyworker Ratio:1:1

Classification	Effective Date	Base Wage	Health	Pension	Supplemental Unemployment	Total Rate
FORK LIFT/CHERRY PICKER <i>OPERATING ENGINEERS LOCAL 4</i>	12/01/2022	\$53.63	\$14.25	\$16.05	\$0.00	\$83.93
	06/01/2023	\$54.88	\$14.25	\$16.05	\$0.00	\$85.18
	12/01/2023	\$56.13	\$14.25	\$16.05	\$0.00	\$86.43
	06/01/2024	\$57.43	\$14.25	\$16.05	\$0.00	\$87.73
	12/01/2024	\$58.88	\$14.25	\$16.05	\$0.00	\$89.18
	06/01/2025	\$60.18	\$14.25	\$16.05	\$0.00	\$90.48
	12/01/2025	\$61.63	\$14.25	\$16.05	\$0.00	\$91.93
	06/01/2026	\$62.93	\$14.25	\$16.05	\$0.00	\$93.23
	12/01/2026	\$64.38	\$14.25	\$16.05	\$0.00	\$94.68
For apprentice rates see "Apprentice- OPERATING ENGINEERS"						
GENERATOR/LIGHTING PLANT/HEATERS <i>OPERATING ENGINEERS LOCAL 4</i>	12/01/2022	\$35.08	\$14.25	\$16.05	\$0.00	\$65.38
	06/01/2023	\$35.90	\$14.25	\$16.05	\$0.00	\$66.20
	12/01/2023	\$36.72	\$14.25	\$16.05	\$0.00	\$67.02
	06/01/2024	\$37.57	\$14.25	\$16.05	\$0.00	\$67.87
	12/01/2024	\$38.52	\$14.25	\$16.05	\$0.00	\$68.82
	06/01/2025	\$39.37	\$14.25	\$16.05	\$0.00	\$69.67
	12/01/2025	\$40.32	\$14.25	\$16.05	\$0.00	\$70.62
	06/01/2026	\$41.18	\$14.25	\$16.05	\$0.00	\$71.48
	12/01/2026	\$42.13	\$14.25	\$16.05	\$0.00	\$72.43
For apprentice rates see "Apprentice- OPERATING ENGINEERS"						
GLAZIER (GLASS PLANK/AIR BARRIER/INTERIOR SYSTEMS) <i>GLAZIERS LOCAL 35 (ZONE 2)</i>	01/01/2023	\$45.56	\$8.65	\$23.05	\$0.00	\$77.26
	07/01/2023	\$46.76	\$8.65	\$23.05	\$0.00	\$78.46
	01/01/2024	\$47.96	\$8.65	\$23.05	\$0.00	\$79.66
	07/01/2024	\$49.16	\$8.65	\$23.05	\$0.00	\$80.86
	01/01/2025	\$50.36	\$8.65	\$23.05	\$0.00	\$82.06

Classification

Effective Date Base Wage Health Pension Supplemental Unemployment Total Rate

Apprentice - GLAZIER - Local 35 Zone 2

Effective Date - 01/01/2023

Step	percent	Apprentice Base Wage	Health	Pension	Supplemental Unemployment	Total Rate
1	50	\$22.78	\$8.65	\$0.00	\$0.00	\$31.43
2	55	\$25.06	\$8.65	\$6.27	\$0.00	\$39.98
3	60	\$27.34	\$8.65	\$6.84	\$0.00	\$42.83
4	65	\$29.61	\$8.65	\$7.41	\$0.00	\$45.67
5	70	\$31.89	\$8.65	\$19.63	\$0.00	\$60.17
6	75	\$34.17	\$8.65	\$20.20	\$0.00	\$63.02
7	80	\$36.45	\$8.65	\$20.77	\$0.00	\$65.87
8	90	\$41.00	\$8.65	\$21.91	\$0.00	\$71.56

Effective Date - 07/01/2023

Step	percent	Apprentice Base Wage	Health	Pension	Supplemental Unemployment	Total Rate
1	50	\$23.38	\$8.65	\$0.00	\$0.00	\$32.03
2	55	\$25.72	\$8.65	\$6.27	\$0.00	\$40.64
3	60	\$28.06	\$8.65	\$6.84	\$0.00	\$43.55
4	65	\$30.39	\$8.65	\$7.41	\$0.00	\$46.45
5	70	\$32.73	\$8.65	\$19.63	\$0.00	\$61.01
6	75	\$35.07	\$8.65	\$20.20	\$0.00	\$63.92
7	80	\$37.41	\$8.65	\$20.77	\$0.00	\$66.83
8	90	\$42.08	\$8.65	\$21.91	\$0.00	\$72.64

Notes:

Steps are 750 hrs.

Apprentice to Journeyworker Ratio:1:1

HOISTING ENGINEER/CRANES/GRADALLS	12/01/2022	\$53.63	\$14.25	\$16.05	\$0.00	\$83.93
OPERATING ENGINEERS LOCAL 4	06/01/2023	\$54.88	\$14.25	\$16.05	\$0.00	\$85.18
	12/01/2023	\$56.13	\$14.25	\$16.05	\$0.00	\$86.43
	06/01/2024	\$57.43	\$14.25	\$16.05	\$0.00	\$87.73
	12/01/2024	\$58.88	\$14.25	\$16.05	\$0.00	\$89.18
	06/01/2025	\$60.18	\$14.25	\$16.05	\$0.00	\$90.48
	12/01/2025	\$61.63	\$14.25	\$16.05	\$0.00	\$91.93
	06/01/2026	\$62.93	\$14.25	\$16.05	\$0.00	\$93.23
	12/01/2026	\$64.38	\$14.25	\$16.05	\$0.00	\$94.68

Classification

Effective Date Base Wage Health Pension Supplemental Unemployment Total Rate

Apprentice - OPERATING ENGINEERS - Local 4

Effective Date - 12/01/2022

Step	percent	Apprentice Base Wage	Health	Pension	Supplemental Unemployment	Total Rate
1	55	\$29.50	\$14.25	\$0.00	\$0.00	\$43.75
2	60	\$32.18	\$14.25	\$16.05	\$0.00	\$62.48
3	65	\$34.86	\$14.25	\$16.05	\$0.00	\$65.16
4	70	\$37.54	\$14.25	\$16.05	\$0.00	\$67.84
5	75	\$40.22	\$14.25	\$16.05	\$0.00	\$70.52
6	80	\$42.90	\$14.25	\$16.05	\$0.00	\$73.20
7	85	\$45.59	\$14.25	\$16.05	\$0.00	\$75.89
8	90	\$48.27	\$14.25	\$16.05	\$0.00	\$78.57

Effective Date - 06/01/2023

Step	percent	Apprentice Base Wage	Health	Pension	Supplemental Unemployment	Total Rate
1	55	\$30.18	\$14.25	\$0.00	\$0.00	\$44.43
2	60	\$32.93	\$14.25	\$16.05	\$0.00	\$63.23
3	65	\$35.67	\$14.25	\$16.05	\$0.00	\$65.97
4	70	\$38.42	\$14.25	\$16.05	\$0.00	\$68.72
5	75	\$41.16	\$14.25	\$16.05	\$0.00	\$71.46
6	80	\$43.90	\$14.25	\$16.05	\$0.00	\$74.20
7	85	\$46.65	\$14.25	\$16.05	\$0.00	\$76.95
8	90	\$49.39	\$14.25	\$16.05	\$0.00	\$79.69

Notes:

Apprentice to Journeyworker Ratio:1:6

HVAC (DUCTWORK) SHEETMETAL WORKERS LOCAL 17 - A	02/01/2023	\$55.31	\$14.11	\$26.64	\$2.83	\$98.89
	08/01/2023	\$57.01	\$14.11	\$26.64	\$2.83	\$100.59
	02/01/2024	\$58.71	\$14.11	\$26.64	\$2.83	\$102.29
	08/01/2024	\$60.46	\$14.11	\$26.64	\$2.83	\$104.04
	02/01/2025	\$62.21	\$14.11	\$26.64	\$2.83	\$105.79
	08/01/2025	\$64.06	\$14.11	\$26.64	\$2.83	\$107.64
	02/01/2026	\$66.01	\$14.11	\$26.64	\$2.83	\$109.59

For apprentice rates see "Apprentice- SHEET METAL WORKER"

HVAC (ELECTRICAL CONTROLS) ELECTRICIANS LOCAL 103	03/01/2023	\$59.23	\$13.00	\$21.63	\$0.00	\$93.86
--	------------	---------	---------	---------	--------	---------

For apprentice rates see "Apprentice- ELECTRICIAN"

HVAC (TESTING AND BALANCING - AIR) SHEETMETAL WORKERS LOCAL 17 - A	02/01/2023	\$55.31	\$14.11	\$26.64	\$2.83	\$98.89
	08/01/2023	\$57.01	\$14.11	\$26.64	\$2.83	\$100.59
	02/01/2024	\$58.71	\$14.11	\$26.64	\$2.83	\$102.29
	08/01/2024	\$60.46	\$14.11	\$26.64	\$2.83	\$104.04
	02/01/2025	\$62.21	\$14.11	\$26.64	\$2.83	\$105.79
	08/01/2025	\$64.06	\$14.11	\$26.64	\$2.83	\$107.64
	02/01/2026	\$66.01	\$14.11	\$26.64	\$2.83	\$109.59

Classification	Effective Date	Base Wage	Health	Pension	Supplemental Unemployment	Total Rate
For apprentice rates see "Apprentice- SHEET METAL WORKER"						
HVAC (TESTING AND BALANCING -WATER) <i>PIPEFITTERS LOCAL 537</i>	03/01/2023	\$63.43	\$12.50	\$20.80	\$0.00	\$96.73
	09/01/2023	\$65.18	\$12.50	\$20.80	\$0.00	\$98.48
	03/01/2024	\$66.98	\$12.50	\$20.80	\$0.00	\$100.28
	09/01/2024	\$68.78	\$12.50	\$20.80	\$0.00	\$102.08
	03/01/2025	\$70.58	\$12.50	\$20.80	\$0.00	\$103.88
For apprentice rates see "Apprentice- PIPEFITTER" or "PLUMBER/PIPEFITTER"						
HVAC MECHANIC <i>PIPEFITTERS LOCAL 537</i>	03/01/2023	\$63.43	\$12.25	\$20.80	\$0.00	\$96.48
	09/01/2023	\$65.18	\$12.25	\$20.80	\$0.00	\$98.23
	03/01/2024	\$66.98	\$12.25	\$20.80	\$0.00	\$100.03
	09/01/2024	\$68.78	\$12.25	\$20.80	\$0.00	\$101.83
	03/01/2025	\$70.58	\$12.25	\$20.80	\$0.00	\$103.63
For apprentice rates see "Apprentice- PIPEFITTER" or "PLUMBER/PIPEFITTER"						
HYDRAULIC DRILLS <i>LABORERS - ZONE 1</i>	12/01/2022	\$43.93	\$9.10	\$17.57	\$0.00	\$70.60
	06/01/2023	\$44.93	\$9.10	\$17.57	\$0.00	\$71.60
	12/01/2023	\$46.18	\$9.10	\$17.57	\$0.00	\$72.85
For apprentice rates see "Apprentice- LABORER"						
HYDRAULIC DRILLS (HEAVY & HIGHWAY) <i>LABORERS - ZONE 1 (HEAVY & HIGHWAY)</i>	12/01/2022	\$43.33	\$9.35	\$17.82	\$0.00	\$70.50
	06/01/2023	\$44.33	\$9.35	\$17.82	\$0.00	\$71.50
	12/01/2023	\$45.58	\$9.35	\$17.82	\$0.00	\$72.75
	06/01/2024	\$47.06	\$9.35	\$17.82	\$0.00	\$74.23
	12/01/2024	\$48.53	\$9.35	\$17.82	\$0.00	\$75.70
	06/01/2025	\$50.03	\$9.35	\$17.82	\$0.00	\$77.20
	12/01/2025	\$51.53	\$9.35	\$17.82	\$0.00	\$78.70
	06/01/2026	\$53.08	\$9.35	\$17.82	\$0.00	\$80.25
	12/01/2026	\$54.58	\$9.35	\$17.82	\$0.00	\$81.75
For apprentice rates see "Apprentice- LABORER (Heavy and Highway)"						
INSULATOR (PIPES & TANKS) <i>HEAT & FROST INSULATORS LOCAL 6 (BOSTON)</i>	09/01/2022	\$53.85	\$13.80	\$17.14	\$0.00	\$84.79

Apprentice - ASBESTOS INSULATOR (Pipes & Tanks) - Local 6 Boston

Effective Date - 09/01/2022

Step	percent	Apprentice Base Wage	Health	Pension	Supplemental Unemployment	Total Rate
1	50	\$26.93	\$13.80	\$12.42	\$0.00	\$53.15
2	60	\$32.31	\$13.80	\$13.36	\$0.00	\$59.47
3	70	\$37.70	\$13.80	\$14.31	\$0.00	\$65.81
4	80	\$43.08	\$13.80	\$15.25	\$0.00	\$72.13

Notes:

Steps are 1 year

Apprentice to Journeyworker Ratio:1:4

IRONWORKER/WELDER <i>IRONWORKERS LOCAL 7 (BOSTON AREA)</i>	09/16/2022	\$51.59	\$8.25	\$26.70	\$0.00	\$86.54
---	------------	---------	--------	---------	--------	---------

Classification

Effective Date Base Wage Health Pension Supplemental Unemployment Total Rate

Apprentice - IRONWORKER - Local 7 Boston

Effective Date - 09/16/2022

Step	percent	Apprentice Base Wage	Health	Pension	Supplemental Unemployment	Total Rate
1	60	\$30.95	\$8.25	\$26.70	\$0.00	\$65.90
2	70	\$36.11	\$8.25	\$26.70	\$0.00	\$71.06
3	75	\$38.69	\$8.25	\$26.70	\$0.00	\$73.64
4	80	\$41.27	\$8.25	\$26.70	\$0.00	\$76.22
5	85	\$43.85	\$8.25	\$26.70	\$0.00	\$78.80
6	90	\$46.43	\$8.25	\$26.70	\$0.00	\$81.38

Notes:

Apprentice to Journeyworker Ratio:1:4

JACKHAMMER & PAVING BREAKER OPERATOR LABORERS - ZONE 1	12/01/2022	\$43.43	\$9.10	\$17.57	\$0.00	\$70.10
	06/01/2023	\$44.43	\$9.10	\$17.57	\$0.00	\$71.10
	12/01/2023	\$45.68	\$9.10	\$17.57	\$0.00	\$72.35

For apprentice rates see "Apprentice- LABORER"

LABORER LABORERS - ZONE 1	12/01/2022	\$43.18	\$9.10	\$17.57	\$0.00	\$69.85
	06/01/2023	\$44.18	\$9.10	\$17.57	\$0.00	\$70.85
	12/01/2023	\$45.43	\$9.10	\$17.57	\$0.00	\$72.10

Apprentice - LABORER - Zone 1

Effective Date - 12/01/2022

Step	percent	Apprentice Base Wage	Health	Pension	Supplemental Unemployment	Total Rate
1	60	\$25.91	\$9.10	\$17.57	\$0.00	\$52.58
2	70	\$30.23	\$9.10	\$17.57	\$0.00	\$56.90
3	80	\$34.54	\$9.10	\$17.57	\$0.00	\$61.21
4	90	\$38.86	\$9.10	\$17.57	\$0.00	\$65.53

Effective Date - 06/01/2023

Step	percent	Apprentice Base Wage	Health	Pension	Supplemental Unemployment	Total Rate
1	60	\$26.51	\$9.10	\$17.57	\$0.00	\$53.18
2	70	\$30.93	\$9.10	\$17.57	\$0.00	\$57.60
3	80	\$35.34	\$9.10	\$17.57	\$0.00	\$62.01
4	90	\$39.76	\$9.10	\$17.57	\$0.00	\$66.43

Notes:

Apprentice to Journeyworker Ratio:1:5

Classification	Effective Date	Base Wage	Health	Pension	Supplemental Unemployment	Total Rate
LABORER (HEAVY & HIGHWAY) LABORERS - ZONE 1 (HEAVY & HIGHWAY)	12/01/2022	\$42.58	\$9.35	\$17.82	\$0.00	\$69.75
	06/01/2023	\$43.58	\$9.35	\$17.82	\$0.00	\$70.75
	12/01/2023	\$44.83	\$9.35	\$17.82	\$0.00	\$72.00
	06/01/2024	\$46.31	\$9.35	\$17.82	\$0.00	\$73.48
	12/01/2024	\$47.78	\$9.35	\$17.82	\$0.00	\$74.95
	06/01/2025	\$49.28	\$9.35	\$17.82	\$0.00	\$76.45
	12/01/2025	\$50.78	\$9.35	\$17.82	\$0.00	\$77.95
	06/01/2026	\$52.33	\$9.35	\$17.82	\$0.00	\$79.50
	12/01/2026	\$53.83	\$9.35	\$17.82	\$0.00	\$81.00

Apprentice - LABORER (Heavy & Highway) - Zone 1

Effective Date - 12/01/2022

Step	percent	Apprentice Base Wage	Health	Pension	Supplemental Unemployment	Total Rate
1	60	\$25.55	\$9.35	\$17.82	\$0.00	\$52.72
2	70	\$29.81	\$9.35	\$17.82	\$0.00	\$56.98
3	80	\$34.06	\$9.35	\$17.82	\$0.00	\$61.23
4	90	\$38.32	\$9.35	\$17.82	\$0.00	\$65.49

Effective Date - 06/01/2023

Step	percent	Apprentice Base Wage	Health	Pension	Supplemental Unemployment	Total Rate
1	60	\$26.15	\$9.35	\$17.82	\$0.00	\$53.32
2	70	\$30.51	\$9.35	\$17.82	\$0.00	\$57.68
3	80	\$34.86	\$9.35	\$17.82	\$0.00	\$62.03
4	90	\$39.22	\$9.35	\$17.82	\$0.00	\$66.39

Notes:

Apprentice to Journeyworker Ratio:1:5

LABORER: CARPENTER TENDER LABORERS - ZONE 1	12/01/2022	\$43.18	\$9.10	\$17.57	\$0.00	\$69.85
	06/01/2023	\$44.18	\$9.10	\$17.57	\$0.00	\$70.85
	12/01/2023	\$45.43	\$9.10	\$17.57	\$0.00	\$72.10

For apprentice rates see "Apprentice- LABORER"

LABORER: CEMENT FINISHER TENDER LABORERS - ZONE 1	12/01/2022	\$43.18	\$9.10	\$17.57	\$0.00	\$69.85
	06/01/2023	\$44.18	\$9.10	\$17.57	\$0.00	\$70.85
	12/01/2023	\$45.43	\$9.10	\$17.57	\$0.00	\$72.10

For apprentice rates see "Apprentice- LABORER"

LABORER: HAZARDOUS WASTE/ASBESTOS REMOVER LABORERS - ZONE 1	12/01/2022	\$43.33	\$9.10	\$17.57	\$0.00	\$70.00
	06/01/2023	\$44.33	\$9.10	\$17.57	\$0.00	\$71.00
	12/01/2023	\$45.58	\$9.10	\$17.57	\$0.00	\$72.25

For apprentice rates see "Apprentice- LABORER"

LABORER: MASON TENDER LABORERS - ZONE 1	12/01/2022	\$43.43	\$9.10	\$17.57	\$0.00	\$70.10
	06/01/2023	\$44.43	\$9.10	\$17.57	\$0.00	\$71.10
	06/01/2024	\$45.68	\$9.10	\$17.57	\$0.00	\$72.35

For apprentice rates see "Apprentice- LABORER"

Classification	Effective Date	Base Wage	Health	Pension	Supplemental Unemployment	Total Rate
LABORER: MASON TENDER (HEAVY & HIGHWAY) <i>LABORERS - ZONE 1 (HEAVY & HIGHWAY)</i>	12/01/2022	\$42.83	\$9.35	\$17.82	\$0.00	\$70.00
	06/01/2023	\$43.83	\$9.35	\$17.82	\$0.00	\$71.00
	12/01/2023	\$45.08	\$9.35	\$17.82	\$0.00	\$72.25
	06/01/2024	\$46.56	\$9.35	\$17.82	\$0.00	\$73.73
	12/01/2024	\$48.03	\$9.35	\$17.82	\$0.00	\$75.20
	06/01/2025	\$49.53	\$9.35	\$17.82	\$0.00	\$76.70
	12/01/2025	\$51.03	\$9.35	\$17.82	\$0.00	\$78.20
	06/01/2026	\$52.58	\$9.35	\$17.82	\$0.00	\$79.75
	12/01/2026	\$54.08	\$9.35	\$17.82	\$0.00	\$81.25
For apprentice rates see "Apprentice- LABORER (Heavy and Highway)						
LABORER: MULTI-TRADE TENDER <i>LABORERS - ZONE 1</i>	12/01/2022	\$43.18	\$9.10	\$17.57	\$0.00	\$69.85
	06/01/2023	\$44.18	\$9.10	\$17.57	\$0.00	\$70.85
	12/01/2023	\$45.43	\$9.10	\$17.57	\$0.00	\$72.10
For apprentice rates see "Apprentice- LABORER"						
LABORER: TREE REMOVER <i>LABORERS - ZONE 1</i>	12/01/2022	\$43.18	\$9.10	\$17.57	\$0.00	\$69.85
	06/01/2023	\$44.18	\$9.10	\$17.57	\$0.00	\$70.85
	12/01/2023	\$45.43	\$9.10	\$17.57	\$0.00	\$72.10
This classification applies to the removal of standing trees, and the trimming and removal of branches and limbs when related to public works construction or site clearance incidental to construction . For apprentice rates see "Apprentice- LABORER"						
LASER BEAM OPERATOR <i>LABORERS - ZONE 1</i>	12/01/2022	\$43.43	\$9.10	\$17.57	\$0.00	\$70.10
	06/01/2023	\$44.43	\$9.10	\$17.57	\$0.00	\$71.10
	12/01/2023	\$45.68	\$9.10	\$17.57	\$0.00	\$72.35
For apprentice rates see "Apprentice- LABORER"						
LASER BEAM OPERATOR (HEAVY & HIGHWAY) <i>LABORERS - ZONE 1 (HEAVY & HIGHWAY)</i>	12/01/2022	\$42.83	\$9.35	\$17.82	\$0.00	\$70.00
	06/01/2023	\$43.83	\$9.35	\$17.82	\$0.00	\$71.00
	12/01/2023	\$45.08	\$9.35	\$17.82	\$0.00	\$72.25
	06/01/2024	\$46.56	\$9.35	\$17.82	\$0.00	\$73.73
	12/01/2024	\$48.03	\$9.35	\$17.82	\$0.00	\$75.20
	06/01/2025	\$49.53	\$9.35	\$17.82	\$0.00	\$76.70
	12/01/2025	\$51.03	\$9.35	\$17.82	\$0.00	\$78.20
	06/01/2026	\$52.58	\$9.35	\$17.82	\$0.00	\$79.75
	12/01/2026	\$54.08	\$9.35	\$17.82	\$0.00	\$81.25
For apprentice rates see "Apprentice- LABORER (Heavy and Highway)						
MARBLE & TILE FINISHERS <i>BRICKLAYERS LOCAL 3 - MARBLE & TILE</i>	02/01/2023	\$46.25	\$11.49	\$20.37	\$0.00	\$78.11
	08/01/2023	\$47.89	\$11.49	\$20.37	\$0.00	\$79.75
	02/01/2024	\$48.89	\$11.49	\$20.37	\$0.00	\$80.75
	08/01/2024	\$50.57	\$11.49	\$20.37	\$0.00	\$82.43
	02/01/2025	\$51.61	\$11.49	\$20.37	\$0.00	\$83.47
	08/01/2025	\$53.33	\$11.49	\$20.37	\$0.00	\$85.19
	02/01/2026	\$54.41	\$11.49	\$20.37	\$0.00	\$86.27
	08/01/2026	\$56.17	\$11.49	\$20.37	\$0.00	\$88.03
	02/01/2027	\$57.29	\$11.49	\$20.37	\$0.00	\$89.15

Classification

Effective Date Base Wage Health Pension Supplemental Unemployment Total Rate

Apprentice - MARBLE & TILE FINISHER - Local 3 Marble & Tile

Effective Date - 02/01/2023

Step	percent	Apprentice Base Wage	Health	Pension	Supplemental Unemployment	Total Rate
1	50	\$23.13	\$11.49	\$20.37	\$0.00	\$54.99
2	60	\$27.75	\$11.49	\$20.37	\$0.00	\$59.61
3	70	\$32.38	\$11.49	\$20.37	\$0.00	\$64.24
4	80	\$37.00	\$11.49	\$20.37	\$0.00	\$68.86
5	90	\$41.63	\$11.49	\$20.37	\$0.00	\$73.49

Effective Date - 08/01/2023

Step	percent	Apprentice Base Wage	Health	Pension	Supplemental Unemployment	Total Rate
1	50	\$23.95	\$11.49	\$20.37	\$0.00	\$55.81
2	60	\$28.73	\$11.49	\$20.37	\$0.00	\$60.59
3	70	\$33.52	\$11.49	\$20.37	\$0.00	\$65.38
4	80	\$38.31	\$11.49	\$20.37	\$0.00	\$70.17
5	90	\$43.10	\$11.49	\$20.37	\$0.00	\$74.96

Notes:

Apprentice to Journeyworker Ratio:1:3

MARBLE MASONS, TILELAYERS & TERRAZZO MECH	02/01/2023	\$60.37	\$11.49	\$22.31	\$0.00	\$94.17
BRICKLAYERS LOCAL 3 - MARBLE & TILE	08/01/2023	\$62.42	\$11.49	\$22.31	\$0.00	\$96.22
	02/01/2024	\$63.67	\$11.49	\$22.31	\$0.00	\$97.47
	08/01/2024	\$65.77	\$11.49	\$22.31	\$0.00	\$99.57
	02/01/2025	\$67.07	\$11.49	\$22.31	\$0.00	\$100.87
	08/01/2025	\$69.22	\$11.49	\$22.31	\$0.00	\$103.02
	02/01/2026	\$70.57	\$11.49	\$22.31	\$0.00	\$104.37
	08/01/2026	\$72.77	\$11.49	\$22.31	\$0.00	\$106.57
	02/01/2027	\$74.17	\$11.49	\$22.31	\$0.00	\$107.97

Classification

Effective Date Base Wage Health Pension Supplemental Unemployment Total Rate

Apprentice - MARBLE-TILE-TERRAZZO MECHANIC - Local 3 Marble & Tile

Effective Date - 02/01/2023

Step	percent	Apprentice Base Wage	Health	Pension	Supplemental Unemployment	Total Rate
1	50	\$30.19	\$11.49	\$22.31	\$0.00	\$63.99
2	60	\$36.22	\$11.49	\$22.31	\$0.00	\$70.02
3	70	\$42.26	\$11.49	\$22.31	\$0.00	\$76.06
4	80	\$48.30	\$11.49	\$22.31	\$0.00	\$82.10
5	90	\$54.33	\$11.49	\$22.31	\$0.00	\$88.13

Effective Date - 08/01/2023

Step	percent	Apprentice Base Wage	Health	Pension	Supplemental Unemployment	Total Rate
1	50	\$31.21	\$11.49	\$22.31	\$0.00	\$65.01
2	60	\$37.45	\$11.49	\$22.31	\$0.00	\$71.25
3	70	\$43.69	\$11.49	\$22.31	\$0.00	\$77.49
4	80	\$49.94	\$11.49	\$22.31	\$0.00	\$83.74
5	90	\$56.18	\$11.49	\$22.31	\$0.00	\$89.98

Notes:

Apprentice to Journeyworker Ratio:1:5

MECH. SWEEPER OPERATOR (ON CONST. SITES) <i>OPERATING ENGINEERS LOCAL 4</i>	12/01/2022	\$53.05	\$14.25	\$16.05	\$0.00	\$83.35
	06/01/2023	\$54.29	\$14.25	\$16.05	\$0.00	\$84.59
	12/01/2023	\$55.53	\$14.25	\$16.05	\$0.00	\$85.83
	06/01/2024	\$56.81	\$14.25	\$16.05	\$0.00	\$87.11
	12/01/2024	\$58.25	\$14.25	\$16.05	\$0.00	\$88.55
	06/01/2025	\$59.53	\$14.25	\$16.05	\$0.00	\$89.83
	12/01/2025	\$60.97	\$14.25	\$16.05	\$0.00	\$91.27
	06/01/2026	\$62.25	\$14.25	\$16.05	\$0.00	\$92.55
	12/01/2026	\$63.69	\$14.25	\$16.05	\$0.00	\$93.99

For apprentice rates see "Apprentice- OPERATING ENGINEERS"

MECHANICS MAINTENANCE <i>OPERATING ENGINEERS LOCAL 4</i>	12/01/2022	\$53.05	\$14.25	\$16.05	\$0.00	\$83.35
	06/01/2023	\$54.29	\$14.25	\$16.05	\$0.00	\$84.59
	12/01/2023	\$55.53	\$14.25	\$16.05	\$0.00	\$85.83
	06/01/2024	\$56.81	\$14.25	\$16.05	\$0.00	\$87.11
	12/01/2024	\$58.25	\$14.25	\$16.05	\$0.00	\$88.55
	06/01/2025	\$59.53	\$14.25	\$16.05	\$0.00	\$89.83
	12/01/2025	\$60.97	\$14.25	\$16.05	\$0.00	\$91.27
	06/01/2026	\$62.25	\$14.25	\$16.05	\$0.00	\$92.55
	12/01/2026	\$63.69	\$14.25	\$16.05	\$0.00	\$93.99

For apprentice rates see "Apprentice- OPERATING ENGINEERS"

MILLWRIGHT (Zone 1) <i>MILLWRIGHTS LOCAL 1121 - Zone 1</i>	01/02/2023	\$47.27	\$8.58	\$21.57	\$0.00	\$77.42
---	------------	---------	--------	---------	--------	---------

Apprentice - MILLWRIGHT - Local 1121 Zone 1

Effective Date - 01/02/2023

Step	percent	Apprentice Base Wage	Health	Pension	Supplemental Unemployment	Total Rate
1	55	\$26.00	\$8.58	\$5.72	\$0.00	\$40.30
2	65	\$30.73	\$8.58	\$17.93	\$0.00	\$57.24
3	75	\$35.45	\$8.58	\$18.98	\$0.00	\$63.01
4	85	\$40.18	\$8.58	\$20.01	\$0.00	\$68.77

Notes: Step 1&2 Appr. indentured after 1/6/2020 receive no pension, but do receive annuity. (Step 1 \$5.72, Step 2 \$6.66)
Steps are 2,000 hours

Apprentice to Journeyworker Ratio:1:4

MORTAR MIXER <i>LABORERS - ZONE 1</i>	12/01/2022	\$43.43	\$9.10	\$17.57	\$0.00	\$70.10
	06/01/2023	\$44.43	\$9.10	\$17.57	\$0.00	\$71.10
	12/01/2023	\$45.68	\$9.10	\$17.57	\$0.00	\$72.35

For apprentice rates see "Apprentice- LABORER"

OILER (OTHER THAN TRUCK CRANES,GRADALLS) <i>OPERATING ENGINEERS LOCAL 4</i>	12/01/2022	\$24.37	\$14.25	\$16.05	\$0.00	\$54.67
	06/01/2023	\$24.94	\$14.25	\$16.05	\$0.00	\$55.24
	12/01/2023	\$25.51	\$14.25	\$16.05	\$0.00	\$55.81
	06/01/2024	\$26.11	\$14.25	\$16.05	\$0.00	\$56.41
	12/01/2024	\$26.77	\$14.25	\$16.05	\$0.00	\$57.07
	06/01/2025	\$27.37	\$14.25	\$16.05	\$0.00	\$57.67
	12/01/2025	\$28.03	\$14.25	\$16.05	\$0.00	\$58.33
	06/01/2026	\$28.62	\$14.25	\$16.05	\$0.00	\$58.92
	12/01/2026	\$29.29	\$14.25	\$16.05	\$0.00	\$59.59

For apprentice rates see "Apprentice- OPERATING ENGINEERS"

OILER (TRUCK CRANES, GRADALLS) <i>OPERATING ENGINEERS LOCAL 4</i>	12/01/2022	\$29.57	\$14.25	\$16.05	\$0.00	\$59.87
	06/01/2023	\$30.27	\$14.25	\$16.05	\$0.00	\$60.57
	12/01/2023	\$30.96	\$14.25	\$16.05	\$0.00	\$61.26
	06/01/2024	\$31.68	\$14.25	\$16.05	\$0.00	\$61.98
	12/01/2024	\$32.48	\$14.25	\$16.05	\$0.00	\$62.78
	06/01/2025	\$33.20	\$14.25	\$16.05	\$0.00	\$63.50
	12/01/2025	\$34.00	\$14.25	\$16.05	\$0.00	\$64.30
	06/01/2026	\$34.72	\$14.25	\$16.05	\$0.00	\$65.02
	12/01/2026	\$35.52	\$14.25	\$16.05	\$0.00	\$65.82

For apprentice rates see "Apprentice- OPERATING ENGINEERS"

OTHER POWER DRIVEN EQUIPMENT - CLASS II <i>OPERATING ENGINEERS LOCAL 4</i>	12/01/2022	\$53.05	\$14.25	\$16.05	\$0.00	\$83.35
	06/01/2023	\$54.29	\$14.25	\$16.05	\$0.00	\$84.59
	12/01/2023	\$55.53	\$14.25	\$16.05	\$0.00	\$85.83
	06/01/2024	\$56.81	\$14.25	\$16.05	\$0.00	\$87.11
	12/01/2024	\$58.25	\$14.25	\$16.05	\$0.00	\$88.55
	06/01/2025	\$59.53	\$14.25	\$16.05	\$0.00	\$89.83
	12/01/2025	\$60.97	\$14.25	\$16.05	\$0.00	\$91.27
	06/01/2026	\$62.25	\$14.25	\$16.05	\$0.00	\$92.55
	12/01/2026	\$63.69	\$14.25	\$16.05	\$0.00	\$93.99

Classification	Effective Date	Base Wage	Health	Pension	Supplemental Unemployment	Total Rate
For apprentice rates see "Apprentice- OPERATING ENGINEERS"						
PAINTER (BRIDGES/TANKS) <i>PAINTERS LOCAL 35 - ZONE 2</i>	01/01/2023	\$56.06	\$8.65	\$23.05	\$0.00	\$87.76
	07/01/2023	\$57.26	\$8.65	\$23.05	\$0.00	\$88.96
	01/01/2024	\$58.46	\$8.65	\$23.05	\$0.00	\$90.16
	07/01/2024	\$59.66	\$8.65	\$23.05	\$0.00	\$91.36
	01/01/2025	\$60.86	\$8.65	\$23.05	\$0.00	\$92.56

Apprentice - PAINTER Local 35 - BRIDGES/TANKS

Effective Date - 01/01/2023

Step	percent	Apprentice Base Wage	Health	Pension	Supplemental Unemployment	Total Rate
1	50	\$28.03	\$8.65	\$0.00	\$0.00	\$36.68
2	55	\$30.83	\$8.65	\$6.27	\$0.00	\$45.75
3	60	\$33.64	\$8.65	\$6.84	\$0.00	\$49.13
4	65	\$36.44	\$8.65	\$7.41	\$0.00	\$52.50
5	70	\$39.24	\$8.65	\$19.63	\$0.00	\$67.52
6	75	\$42.05	\$8.65	\$20.20	\$0.00	\$70.90
7	80	\$44.85	\$8.65	\$20.77	\$0.00	\$74.27
8	90	\$50.45	\$8.65	\$21.91	\$0.00	\$81.01

Effective Date - 07/01/2023

Step	percent	Apprentice Base Wage	Health	Pension	Supplemental Unemployment	Total Rate
1	50	\$28.63	\$8.65	\$0.00	\$0.00	\$37.28
2	55	\$31.49	\$8.65	\$6.27	\$0.00	\$46.41
3	60	\$34.36	\$8.65	\$6.84	\$0.00	\$49.85
4	65	\$37.22	\$8.65	\$7.41	\$0.00	\$53.28
5	70	\$40.08	\$8.65	\$19.63	\$0.00	\$68.36
6	75	\$42.95	\$8.65	\$20.20	\$0.00	\$71.80
7	80	\$45.81	\$8.65	\$20.77	\$0.00	\$75.23
8	90	\$51.53	\$8.65	\$21.91	\$0.00	\$82.09

Notes:

Steps are 750 hrs.

Apprentice to Journeyworker Ratio:1:1

PAINTER (SPRAY OR SANDBLAST, NEW) *	01/01/2023	\$46.96	\$8.65	\$23.05	\$0.00	\$78.66
* If 30% or more of surfaces to be painted are new construction, NEW paint rate shall be used. <i>PAINTERS LOCAL 35 - ZONE 2</i>	07/01/2023	\$48.16	\$8.65	\$23.05	\$0.00	\$79.86
	01/01/2024	\$49.36	\$8.65	\$23.05	\$0.00	\$81.06
	07/01/2024	\$50.56	\$8.65	\$23.05	\$0.00	\$82.26
	01/01/2025	\$51.76	\$8.65	\$23.05	\$0.00	\$83.46

Classification

Effective Date Base Wage Health Pension Supplemental Unemployment Total Rate

Apprentice - PAINTER Local 35 Zone 2 - Spray/Sandblast - New

Effective Date - 01/01/2023

Step	percent	Apprentice Base Wage	Health	Pension	Supplemental Unemployment	Total Rate
1	50	\$23.48	\$8.65	\$0.00	\$0.00	\$32.13
2	55	\$25.83	\$8.65	\$6.27	\$0.00	\$40.75
3	60	\$28.18	\$8.65	\$6.84	\$0.00	\$43.67
4	65	\$30.52	\$8.65	\$7.41	\$0.00	\$46.58
5	70	\$32.87	\$8.65	\$19.63	\$0.00	\$61.15
6	75	\$35.22	\$8.65	\$20.20	\$0.00	\$64.07
7	80	\$37.57	\$8.65	\$20.77	\$0.00	\$66.99
8	90	\$42.26	\$8.65	\$21.91	\$0.00	\$72.82

Effective Date - 07/01/2023

Step	percent	Apprentice Base Wage	Health	Pension	Supplemental Unemployment	Total Rate
1	50	\$24.08	\$8.65	\$0.00	\$0.00	\$32.73
2	55	\$26.49	\$8.65	\$6.27	\$0.00	\$41.41
3	60	\$28.90	\$8.65	\$6.84	\$0.00	\$44.39
4	65	\$31.30	\$8.65	\$7.41	\$0.00	\$47.36
5	70	\$33.71	\$8.65	\$19.63	\$0.00	\$61.99
6	75	\$36.12	\$8.65	\$20.20	\$0.00	\$64.97
7	80	\$38.53	\$8.65	\$20.77	\$0.00	\$67.95
8	90	\$43.34	\$8.65	\$21.91	\$0.00	\$73.90

Notes:

Steps are 750 hrs.

Apprentice to Journeyworker Ratio:1:1

PAINTER (SPRAY OR SANDBLAST, REPAINT)	01/01/2023	\$45.02	\$8.65	\$23.05	\$0.00	\$76.72
PAINTERS LOCAL 35 - ZONE 2	07/01/2023	\$46.22	\$8.65	\$23.05	\$0.00	\$77.92
	01/01/2024	\$47.42	\$8.65	\$23.05	\$0.00	\$79.12
	07/01/2024	\$48.62	\$8.65	\$23.05	\$0.00	\$80.32
	01/01/2025	\$49.82	\$8.65	\$23.05	\$0.00	\$81.52

Classification

Effective Date Base Wage Health Pension Supplemental Unemployment Total Rate

Apprentice - PAINTER Local 35 Zone 2 - Spray/Sandblast - Repaint

Effective Date - 01/01/2023

Step	percent	Apprentice Base Wage	Health	Pension	Supplemental Unemployment	Total Rate
1	50	\$22.51	\$8.65	\$0.00	\$0.00	\$31.16
2	55	\$24.76	\$8.65	\$6.27	\$0.00	\$39.68
3	60	\$27.01	\$8.65	\$6.84	\$0.00	\$42.50
4	65	\$29.26	\$8.65	\$7.41	\$0.00	\$45.32
5	70	\$31.51	\$8.65	\$19.63	\$0.00	\$59.79
6	75	\$33.77	\$8.65	\$20.20	\$0.00	\$62.62
7	80	\$36.02	\$8.65	\$20.77	\$0.00	\$65.44
8	90	\$40.52	\$8.65	\$21.91	\$0.00	\$71.08

Effective Date - 07/01/2023

Step	percent	Apprentice Base Wage	Health	Pension	Supplemental Unemployment	Total Rate
1	50	\$23.11	\$8.65	\$0.00	\$0.00	\$31.76
2	55	\$25.42	\$8.65	\$6.27	\$0.00	\$40.34
3	60	\$27.73	\$8.65	\$6.84	\$0.00	\$43.22
4	65	\$30.04	\$8.65	\$19.06	\$0.00	\$57.75
5	70	\$32.35	\$8.65	\$19.63	\$0.00	\$60.63
6	75	\$34.67	\$8.65	\$20.20	\$0.00	\$63.52
7	80	\$36.98	\$8.65	\$20.77	\$0.00	\$66.40
8	90	\$41.60	\$8.65	\$21.91	\$0.00	\$72.16

Notes:

Steps are 750 hrs.

Apprentice to Journeyworker Ratio:1:1

PAINTER / TAPER (BRUSH, NEW) *	01/01/2023	\$45.56	\$8.65	\$23.05	\$0.00	\$77.26
* If 30% or more of surfaces to be painted are new construction, NEW paint rate shall be used. <i>PAINTERS LOCAL 35 - ZONE 2</i>	07/01/2023	\$46.76	\$8.65	\$23.05	\$0.00	\$78.46
	01/01/2024	\$47.96	\$8.65	\$23.05	\$0.00	\$79.66
	07/01/2024	\$49.16	\$8.65	\$23.05	\$0.00	\$80.86
	01/01/2025	\$50.36	\$8.65	\$23.05	\$0.00	\$82.06

Apprentice - PAINTER - Local 35 Zone 2 - BRUSH NEW

Effective Date - 01/01/2023

Step	percent	Apprentice Base Wage	Health	Pension	Supplemental Unemployment	Total Rate
1	50	\$22.78	\$8.65	\$0.00	\$0.00	\$31.43
2	55	\$25.06	\$8.65	\$6.27	\$0.00	\$39.98
3	60	\$27.34	\$8.65	\$6.84	\$0.00	\$42.83
4	65	\$29.61	\$8.65	\$7.41	\$0.00	\$45.67
5	70	\$31.89	\$8.65	\$19.63	\$0.00	\$60.17
6	75	\$34.17	\$8.65	\$20.20	\$0.00	\$63.02
7	80	\$36.45	\$8.65	\$20.77	\$0.00	\$65.87
8	90	\$41.00	\$8.65	\$21.91	\$0.00	\$71.56

Effective Date - 07/01/2023

Step	percent	Apprentice Base Wage	Health	Pension	Supplemental Unemployment	Total Rate
1	50	\$23.38	\$8.65	\$0.00	\$0.00	\$32.03
2	55	\$25.72	\$8.65	\$6.27	\$0.00	\$40.64
3	60	\$28.06	\$8.65	\$6.84	\$0.00	\$43.55
4	65	\$30.39	\$8.65	\$7.41	\$0.00	\$46.45
5	70	\$32.73	\$8.65	\$19.63	\$0.00	\$61.01
6	75	\$35.07	\$8.65	\$20.20	\$0.00	\$63.92
7	80	\$37.41	\$8.65	\$20.77	\$0.00	\$66.83
8	90	\$42.08	\$8.65	\$21.91	\$0.00	\$72.64

Notes:

Steps are 750 hrs.

Apprentice to Journeyworker Ratio:1:1

PAINTER / TAPER (BRUSH, REPAINT)	01/01/2023	\$43.62	\$8.65	\$23.05	\$0.00	\$75.32
PAINTERS LOCAL 35 - ZONE 2	07/01/2023	\$44.82	\$8.65	\$23.05	\$0.00	\$76.52
	01/01/2024	\$46.02	\$8.65	\$23.05	\$0.00	\$77.72
	07/01/2024	\$47.22	\$8.65	\$23.05	\$0.00	\$78.92
	01/01/2025	\$48.42	\$8.65	\$23.05	\$0.00	\$80.12

Classification

Effective Date Base Wage Health Pension Supplemental Unemployment Total Rate

Apprentice - PAINTER Local 35 Zone 2 - BRUSH REPAINT

Effective Date - 01/01/2023

Step	percent	Apprentice Base Wage	Health	Pension	Supplemental Unemployment	Total Rate
1	50	\$21.81	\$8.65	\$0.00	\$0.00	\$30.46
2	55	\$23.99	\$8.65	\$6.27	\$0.00	\$38.91
3	60	\$26.17	\$8.65	\$6.84	\$0.00	\$41.66
4	65	\$28.35	\$8.65	\$7.41	\$0.00	\$44.41
5	70	\$30.53	\$8.65	\$19.63	\$0.00	\$58.81
6	75	\$32.72	\$8.65	\$20.20	\$0.00	\$61.57
7	80	\$34.90	\$8.65	\$20.77	\$0.00	\$64.32
8	90	\$39.26	\$8.65	\$21.91	\$0.00	\$69.82

Effective Date - 07/01/2023

Step	percent	Apprentice Base Wage	Health	Pension	Supplemental Unemployment	Total Rate
1	50	\$22.41	\$8.65	\$0.00	\$0.00	\$31.06
2	55	\$24.65	\$8.65	\$6.27	\$0.00	\$39.57
3	60	\$26.89	\$8.65	\$6.84	\$0.00	\$42.38
4	65	\$29.13	\$8.65	\$7.41	\$0.00	\$45.19
5	70	\$31.37	\$8.65	\$19.63	\$0.00	\$59.65
6	75	\$33.62	\$8.65	\$20.20	\$0.00	\$62.47
7	80	\$35.86	\$8.65	\$20.77	\$0.00	\$65.28
8	90	\$40.34	\$8.65	\$21.91	\$0.00	\$70.90

Notes:
Steps are 750 hrs.

Apprentice to Journeyworker Ratio:1:1

PAINTER TRAFFIC MARKINGS (HEAVY/HIGHWAY)	12/01/2022	\$42.58	\$9.35	\$17.82	\$0.00	\$69.75
LABORERS - ZONE 1 (HEAVY & HIGHWAY)	06/01/2023	\$43.58	\$9.35	\$17.82	\$0.00	\$70.75
	12/01/2023	\$44.83	\$9.35	\$17.82	\$0.00	\$72.00
	06/01/2024	\$46.31	\$9.35	\$17.82	\$0.00	\$73.48
	12/01/2024	\$47.78	\$9.35	\$17.82	\$0.00	\$74.95
	06/01/2025	\$49.28	\$9.35	\$17.82	\$0.00	\$76.45
	12/01/2025	\$50.78	\$9.35	\$17.82	\$0.00	\$77.95
	06/01/2026	\$52.33	\$9.35	\$17.82	\$0.00	\$79.50
	12/01/2026	\$53.83	\$9.35	\$17.82	\$0.00	\$81.00

For apprentice rates see "Apprentice- LABORER (Heavy and Highway)

PANEL & PICKUP TRUCKS DRIVER	12/01/2021	\$36.88	\$13.41	\$16.01	\$0.00	\$66.30
TEAMSTERS JOINT COUNCIL NO. 10 ZONE A						

PIER AND DOCK CONSTRUCTOR (UNDERPINNING AND DECK)	08/01/2020	\$49.07	\$9.40	\$23.12	\$0.00	\$81.59
PILE DRIVER LOCAL 56 (ZONE 1)						

For apprentice rates see "Apprentice- PILE DRIVER"

PILE DRIVER	08/01/2020	\$49.07	\$9.40	\$23.12	\$0.00	\$81.59
PILE DRIVER LOCAL 56 (ZONE 1)						

Apprentice - PILE DRIVER - Local 56 Zone 1

Effective Date - 08/01/2020

Step	percent	Apprentice Base Wage	Health	Pension	Supplemental Unemployment	Total Rate
1	50	\$24.54	\$9.40	\$23.12	\$0.00	\$57.06
2	60	\$29.44	\$9.40	\$23.12	\$0.00	\$61.96
3	70	\$34.35	\$9.40	\$23.12	\$0.00	\$66.87
4	75	\$36.80	\$9.40	\$23.12	\$0.00	\$69.32
5	80	\$39.26	\$9.40	\$23.12	\$0.00	\$71.78
6	80	\$39.26	\$9.40	\$23.12	\$0.00	\$71.78
7	90	\$44.16	\$9.40	\$23.12	\$0.00	\$76.68
8	90	\$44.16	\$9.40	\$23.12	\$0.00	\$76.68

Notes:

% Indentured After 10/1/17; 45/45/55/55/70/70/80/80
 Step 1&2 \$34.01/ 3&4 \$41.46/ 5&6 \$62.80/ 7&8 \$69.25

Apprentice to Journeyworker Ratio:1:5

PIPEFITTER & STEAMFITTER
PIPEFITTERS LOCAL 537

03/01/2023	\$63.43	\$12.25	\$20.80	\$0.00	\$96.48
09/01/2023	\$65.18	\$12.25	\$20.80	\$0.00	\$98.23
03/01/2024	\$66.98	\$12.25	\$20.80	\$0.00	\$100.03
09/01/2024	\$68.78	\$12.25	\$20.80	\$0.00	\$101.83
03/01/2025	\$70.58	\$12.25	\$20.80	\$0.00	\$103.63

Apprentice - PIPEFITTER - Local 537

Effective Date - 03/01/2023

Step	percent	Apprentice Base Wage	Health	Pension	Supplemental Unemployment	Total Rate
1	40	\$25.37	\$12.25	\$8.55	\$0.00	\$46.17
2	45	\$28.54	\$12.25	\$20.80	\$0.00	\$61.59
3	60	\$38.06	\$12.25	\$20.80	\$0.00	\$71.11
4	70	\$44.40	\$12.25	\$20.80	\$0.00	\$77.45
5	80	\$50.74	\$12.25	\$20.80	\$0.00	\$83.79

Effective Date - 09/01/2023

Step	percent	Apprentice Base Wage	Health	Pension	Supplemental Unemployment	Total Rate
1	40	\$26.07	\$12.25	\$8.55	\$0.00	\$46.87
2	45	\$29.33	\$12.25	\$20.80	\$0.00	\$62.38
3	60	\$39.11	\$12.25	\$20.80	\$0.00	\$72.16
4	70	\$45.63	\$12.25	\$20.80	\$0.00	\$78.68
5	80	\$52.14	\$12.25	\$20.80	\$0.00	\$85.19

Notes:

** 1:3; 3:15; 1:10 thereafter / Steps are 1 yr.
 Refrig/AC Mechanic **1:1;1:2;2:4;3:6;4:8;5:10;6:12;7:14;8:17;9:20;10:23(Max)

Apprentice to Journeyworker Ratio:**

Classification	Effective Date	Base Wage	Health	Pension	Supplemental Unemployment	Total Rate
PIPELAYER LABORERS - ZONE 1	12/01/2022	\$43.43	\$9.10	\$17.57	\$0.00	\$70.10
	06/01/2023	\$44.43	\$9.10	\$17.57	\$0.00	\$71.10
	12/01/2023	\$45.68	\$9.10	\$17.57	\$0.00	\$72.35

For apprentice rates see "Apprentice- LABORER"

PIPELAYER (HEAVY & HIGHWAY) LABORERS - ZONE 1 (HEAVY & HIGHWAY)	12/01/2022	\$42.83	\$9.35	\$17.82	\$0.00	\$70.00
	06/01/2023	\$43.83	\$9.35	\$17.82	\$0.00	\$71.00
	12/01/2023	\$45.08	\$9.35	\$17.82	\$0.00	\$72.25
	06/01/2024	\$46.56	\$9.35	\$17.82	\$0.00	\$73.73
	12/01/2024	\$48.03	\$9.35	\$17.82	\$0.00	\$75.20
	06/01/2025	\$49.53	\$9.35	\$17.82	\$0.00	\$76.70
	12/01/2025	\$51.03	\$9.35	\$17.82	\$0.00	\$78.20
	06/01/2026	\$52.58	\$9.35	\$17.82	\$0.00	\$79.75
	12/01/2026	\$54.08	\$9.35	\$17.82	\$0.00	\$81.25

For apprentice rates see "Apprentice- LABORER (Heavy and Highway)"

PLUMBERS & GASFITTERS PLUMBERS & GASFITTERS LOCAL 12	02/26/2023	\$65.19	\$14.07	\$18.36	\$0.00	\$97.62
	09/03/2023	\$66.94	\$14.07	\$18.36	\$0.00	\$99.37
	03/03/2024	\$68.74	\$14.07	\$18.36	\$0.00	\$101.17
	09/01/2024	\$70.54	\$14.07	\$18.36	\$0.00	\$102.97
	03/02/2025	\$72.34	\$14.07	\$18.36	\$0.00	\$104.77

Apprentice - PLUMBER/GASFITTER - Local 12

Effective Date - 02/26/2023

Step	percent	Apprentice Base Wage	Health	Pension	Supplemental Unemployment	Total Rate
1	35	\$22.82	\$14.07	\$6.63	\$0.00	\$43.52
2	40	\$26.08	\$14.07	\$7.52	\$0.00	\$47.67
3	55	\$35.85	\$14.07	\$10.24	\$0.00	\$60.16
4	65	\$42.37	\$14.07	\$12.04	\$0.00	\$68.48
5	75	\$48.89	\$14.07	\$13.85	\$0.00	\$76.81

Effective Date - 09/03/2023

Step	percent	Apprentice Base Wage	Health	Pension	Supplemental Unemployment	Total Rate
1	35	\$23.43	\$14.07	\$6.63	\$0.00	\$44.13
2	40	\$26.78	\$14.07	\$7.52	\$0.00	\$48.37
3	55	\$36.82	\$14.07	\$10.24	\$0.00	\$61.13
4	65	\$43.51	\$14.07	\$12.04	\$0.00	\$69.62
5	75	\$50.21	\$14.07	\$13.85	\$0.00	\$78.13

Notes:

** 1:2; 2:6; 3:10; 4:14; 5:19/Steps are 1 yr
Step4 with lic\$69.00, Step5 with lic\$76.87

Apprentice to Journeyworker Ratio:**

PNEUMATIC CONTROLS (TEMP.) PIPEFITTERS LOCAL 537	03/01/2023	\$63.43	\$12.00	\$20.80	\$0.00	\$96.23
	09/01/2023	\$65.18	\$12.00	\$20.80	\$0.00	\$97.98
	03/01/2024	\$66.98	\$12.00	\$20.80	\$0.00	\$99.78
	09/01/2024	\$68.78	\$12.00	\$20.80	\$0.00	\$101.58
	03/01/2025	\$70.58	\$12.00	\$20.80	\$0.00	\$103.38

Classification	Effective Date	Base Wage	Health	Pension	Supplemental Unemployment	Total Rate
For apprentice rates see "Apprentice- PIPEFITTER" or "PLUMBER/PIPEFITTER"						
PNEUMATIC DRILL/TOOL OPERATOR <i>LABORERS - ZONE 1</i>	12/01/2022	\$43.43	\$9.10	\$17.57	\$0.00	\$70.10
	06/01/2023	\$44.43	\$9.10	\$17.57	\$0.00	\$71.10
	12/01/2023	\$45.68	\$9.10	\$17.57	\$0.00	\$72.35
For apprentice rates see "Apprentice- LABORER"						
PNEUMATIC DRILL/TOOL OPERATOR (HEAVY & HIGHWAY) <i>LABORERS - ZONE 1 (HEAVY & HIGHWAY)</i>	12/01/2022	\$42.83	\$9.35	\$17.82	\$0.00	\$70.00
	06/01/2023	\$43.83	\$9.35	\$17.82	\$0.00	\$71.00
	12/01/2023	\$45.08	\$9.35	\$17.82	\$0.00	\$72.25
	06/01/2024	\$46.56	\$9.35	\$17.82	\$0.00	\$73.73
	12/01/2024	\$48.03	\$9.35	\$17.82	\$0.00	\$75.20
	06/01/2025	\$49.53	\$9.35	\$17.82	\$0.00	\$76.70
	12/01/2025	\$51.03	\$9.35	\$17.82	\$0.00	\$78.20
	06/01/2026	\$52.58	\$9.35	\$17.82	\$0.00	\$79.75
	12/01/2026	\$54.08	\$9.35	\$17.82	\$0.00	\$81.25
For apprentice rates see "Apprentice- LABORER (Heavy and Highway)"						
POWDERMAN & BLASTER <i>LABORERS - ZONE 1</i>	12/01/2022	\$44.18	\$9.10	\$17.57	\$0.00	\$70.85
	06/01/2023	\$45.18	\$9.10	\$17.57	\$0.00	\$71.85
	12/01/2023	\$46.43	\$9.10	\$17.57	\$0.00	\$73.10
For apprentice rates see "Apprentice- LABORER"						
POWDERMAN & BLASTER (HEAVY & HIGHWAY) <i>LABORERS - ZONE 1 (HEAVY & HIGHWAY)</i>	12/01/2022	\$43.58	\$9.35	\$17.82	\$0.00	\$70.75
	06/01/2023	\$44.58	\$9.35	\$17.82	\$0.00	\$71.75
	12/01/2023	\$45.83	\$9.35	\$17.82	\$0.00	\$73.00
	06/01/2024	\$47.31	\$9.35	\$17.82	\$0.00	\$74.48
	12/01/2024	\$48.78	\$9.35	\$17.82	\$0.00	\$75.95
	06/01/2025	\$50.28	\$9.35	\$17.82	\$0.00	\$77.45
	12/01/2025	\$51.78	\$9.35	\$17.82	\$0.00	\$78.95
	06/01/2026	\$53.33	\$9.35	\$17.82	\$0.00	\$80.50
	12/01/2026	\$54.83	\$9.35	\$17.82	\$0.00	\$82.00
For apprentice rates see "Apprentice- LABORER (Heavy and Highway)"						
POWER SHOVEL/DERRICK/TRENCHING MACHINE <i>OPERATING ENGINEERS LOCAL 4</i>	12/01/2022	\$53.63	\$14.25	\$16.05	\$0.00	\$83.93
	06/01/2023	\$54.88	\$14.25	\$16.05	\$0.00	\$85.18
	12/01/2023	\$56.13	\$14.25	\$16.05	\$0.00	\$86.43
	06/01/2024	\$57.43	\$14.25	\$16.05	\$0.00	\$87.73
	12/01/2024	\$58.88	\$14.25	\$16.05	\$0.00	\$89.18
	06/01/2025	\$60.18	\$14.25	\$16.05	\$0.00	\$90.48
	12/01/2025	\$61.63	\$14.25	\$16.05	\$0.00	\$91.93
	06/01/2026	\$62.93	\$14.25	\$16.05	\$0.00	\$93.23
	12/01/2026	\$64.38	\$14.25	\$16.05	\$0.00	\$94.68
For apprentice rates see "Apprentice- OPERATING ENGINEERS"						

Classification	Effective Date	Base Wage	Health	Pension	Supplemental Unemployment	Total Rate
PUMP OPERATOR (CONCRETE) <i>OPERATING ENGINEERS LOCAL 4</i>	12/01/2022	\$53.63	\$14.25	\$16.05	\$0.00	\$83.93
	06/01/2023	\$54.88	\$14.25	\$16.05	\$0.00	\$85.18
	12/01/2023	\$56.13	\$14.25	\$16.05	\$0.00	\$86.43
	06/01/2024	\$57.43	\$14.25	\$16.05	\$0.00	\$87.73
	12/01/2024	\$58.88	\$14.25	\$16.05	\$0.00	\$89.18
	06/01/2025	\$60.18	\$14.25	\$16.05	\$0.00	\$90.48
	12/01/2025	\$61.63	\$14.25	\$16.05	\$0.00	\$91.93
	06/01/2026	\$62.93	\$14.25	\$16.05	\$0.00	\$93.23
	12/01/2026	\$64.38	\$14.25	\$16.05	\$0.00	\$94.68
For apprentice rates see "Apprentice- OPERATING ENGINEERS"						
PUMP OPERATOR (DEWATERING, OTHER) <i>OPERATING ENGINEERS LOCAL 4</i>	12/01/2022	\$35.08	\$14.25	\$16.05	\$0.00	\$65.38
	06/01/2023	\$35.90	\$14.25	\$16.05	\$0.00	\$66.20
	12/01/2023	\$36.72	\$14.25	\$16.05	\$0.00	\$67.02
	06/01/2024	\$37.57	\$14.25	\$16.05	\$0.00	\$67.87
	12/01/2024	\$38.52	\$14.25	\$16.05	\$0.00	\$68.82
	06/01/2025	\$39.37	\$14.25	\$16.05	\$0.00	\$69.67
	12/01/2025	\$40.32	\$14.25	\$16.05	\$0.00	\$70.62
	06/01/2026	\$41.18	\$14.25	\$16.05	\$0.00	\$71.48
	12/01/2026	\$42.13	\$14.25	\$16.05	\$0.00	\$72.43
For apprentice rates see "Apprentice- OPERATING ENGINEERS"						
READY MIX CONCRETE DRIVERS after 4/30/12 (Drivers Hired After 4/30/2012) <i>TEAMSTERS 25 (Metro) - Aggregate</i>	08/01/2022	\$30.40	\$11.91	\$15.25	\$0.00	\$57.56
READY-MIX CONCRETE DRIVER <i>TEAMSTERS 25 (Metro) - Aggregate</i>	08/01/2022	\$34.41	\$11.91	\$15.25	\$0.00	\$61.57
RECLAIMERS <i>OPERATING ENGINEERS LOCAL 4</i>	12/01/2022	\$53.05	\$14.25	\$16.05	\$0.00	\$83.35
	06/01/2023	\$54.29	\$14.25	\$16.05	\$0.00	\$84.59
	12/01/2023	\$55.53	\$14.25	\$16.05	\$0.00	\$85.83
	06/01/2024	\$56.81	\$14.25	\$16.05	\$0.00	\$87.11
	12/01/2024	\$58.25	\$14.25	\$16.05	\$0.00	\$88.55
	06/01/2025	\$59.53	\$14.25	\$16.05	\$0.00	\$89.83
	12/01/2025	\$60.97	\$14.25	\$16.05	\$0.00	\$91.27
	06/01/2026	\$62.25	\$14.25	\$16.05	\$0.00	\$92.55
	12/01/2026	\$63.69	\$14.25	\$16.05	\$0.00	\$93.99
For apprentice rates see "Apprentice- OPERATING ENGINEERS"						
RIDE-ON MOTORIZED BUGGY OPERATOR <i>LABORERS - ZONE 1</i>	12/01/2022	\$43.43	\$9.10	\$17.57	\$0.00	\$70.10
	06/01/2023	\$44.43	\$9.10	\$17.57	\$0.00	\$71.10
	12/01/2023	\$45.68	\$9.10	\$17.57	\$0.00	\$72.35
For apprentice rates see "Apprentice- LABORER"						
ROLLER/SPREADER/MULCHING MACHINE <i>OPERATING ENGINEERS LOCAL 4</i>	12/01/2022	\$53.05	\$14.25	\$16.05	\$0.00	\$83.35
	06/01/2023	\$54.29	\$14.25	\$16.05	\$0.00	\$84.59
	12/01/2023	\$55.53	\$14.25	\$16.05	\$0.00	\$85.83
	06/01/2024	\$56.81	\$14.25	\$16.05	\$0.00	\$87.11
	12/01/2024	\$58.25	\$14.25	\$16.05	\$0.00	\$88.55
	06/01/2025	\$59.53	\$14.25	\$16.05	\$0.00	\$89.83
	12/01/2025	\$60.97	\$14.25	\$16.05	\$0.00	\$91.27
	06/01/2026	\$62.25	\$14.25	\$16.05	\$0.00	\$92.55
	12/01/2026	\$63.69	\$14.25	\$16.05	\$0.00	\$93.99

Classification	Effective Date	Base Wage	Health	Pension	Supplemental Unemployment	Total Rate
For apprentice rates see "Apprentice- OPERATING ENGINEERS"						
ROOFER (Inc.Roofing Waterproofing &Roofing Damproofg) ROOFERS LOCAL 33	02/01/2023	\$48.53	\$12.78	\$20.20	\$0.00	\$81.51
	08/01/2023	\$50.03	\$12.78	\$20.20	\$0.00	\$83.01
	02/01/2024	\$51.28	\$12.78	\$20.20	\$0.00	\$84.26
	08/01/2024	\$52.78	\$12.78	\$20.20	\$0.00	\$85.76
	02/01/2025	\$54.03	\$12.78	\$20.20	\$0.00	\$87.01
	08/01/2025	\$55.53	\$12.78	\$20.20	\$0.00	\$88.51
	02/01/2026	\$56.78	\$12.78	\$20.20	\$0.00	\$89.76

Apprentice - ROOFER - Local 33

Effective Date - 02/01/2023

Step	percent	Apprentice Base Wage	Health	Pension	Supplemental Unemployment	Total Rate
1	50	\$24.27	\$12.78	\$5.59	\$0.00	\$42.64
2	60	\$29.12	\$12.78	\$20.20	\$0.00	\$62.10
3	65	\$31.54	\$12.78	\$20.20	\$0.00	\$64.52
4	75	\$36.40	\$12.78	\$20.20	\$0.00	\$69.38
5	85	\$41.25	\$12.78	\$20.20	\$0.00	\$74.23

Effective Date - 08/01/2023

Step	percent	Apprentice Base Wage	Health	Pension	Supplemental Unemployment	Total Rate
1	50	\$25.02	\$12.78	\$5.59	\$0.00	\$43.39
2	60	\$30.02	\$12.78	\$20.20	\$0.00	\$63.00
3	65	\$32.52	\$12.78	\$20.20	\$0.00	\$65.50
4	75	\$37.52	\$12.78	\$20.20	\$0.00	\$70.50
5	85	\$42.53	\$12.78	\$20.20	\$0.00	\$75.51

Notes: ** 1:5, 2:6-10, the 1:10; Reroofing: 1:4, then 1:1
 Step 1 is 2000 hrs.; Steps 2-5 are 1000 hrs.
 (Hot Pitch Mechanics' receive \$1.00 hr. above ROOFER)

Apprentice to Journeyworker Ratio:**

ROOFER SLATE / TILE / PRECAST CONCRETE ROOFERS LOCAL 33	02/01/2023	\$48.78	\$12.78	\$20.20	\$0.00	\$81.76
	08/01/2023	\$50.28	\$12.78	\$20.20	\$0.00	\$83.26
	02/01/2024	\$51.53	\$12.78	\$20.20	\$0.00	\$84.51
	08/01/2024	\$53.03	\$12.78	\$20.20	\$0.00	\$86.01
	02/01/2025	\$54.28	\$12.78	\$20.20	\$0.00	\$87.26
	08/01/2025	\$55.78	\$12.78	\$20.20	\$0.00	\$88.76
	02/01/2026	\$57.03	\$12.78	\$20.20	\$0.00	\$90.01

For apprentice rates see "Apprentice- ROOFER"

SHEETMETAL WORKER SHEETMETAL WORKERS LOCAL 17 - A	02/01/2023	\$55.31	\$14.11	\$26.64	\$2.83	\$98.89
	08/01/2023	\$57.01	\$14.11	\$26.64	\$2.83	\$100.59
	02/01/2024	\$58.71	\$14.11	\$26.64	\$2.83	\$102.29
	08/01/2024	\$60.46	\$14.11	\$26.64	\$2.83	\$104.04
	02/01/2025	\$62.21	\$14.11	\$26.64	\$2.83	\$105.79
	08/01/2025	\$64.06	\$14.11	\$26.64	\$2.83	\$107.64
	02/01/2026	\$66.01	\$14.11	\$26.64	\$2.83	\$109.59

Classification

Effective Date Base Wage Health Pension Supplemental Unemployment Total Rate

Apprentice - SHEET METAL WORKER - Local 17-A

Effective Date - 02/01/2023

Step	percent	Apprentice Base Wage	Health	Pension	Supplemental Unemployment	Total Rate
1	42	\$23.23	\$14.11	\$6.13	\$0.00	\$43.47
2	42	\$23.23	\$14.11	\$6.13	\$0.00	\$43.47
3	47	\$26.00	\$14.11	\$11.90	\$1.54	\$53.55
4	47	\$26.00	\$14.11	\$11.90	\$1.54	\$53.55
5	52	\$28.76	\$14.11	\$12.88	\$1.65	\$57.40
6	52	\$28.76	\$14.11	\$13.13	\$1.65	\$57.65
7	60	\$33.19	\$14.11	\$14.54	\$1.83	\$63.67
8	65	\$35.95	\$14.11	\$15.52	\$1.94	\$67.52
9	75	\$41.48	\$14.11	\$17.48	\$2.16	\$75.23
10	85	\$47.01	\$14.11	\$18.94	\$2.36	\$82.42

Effective Date - 08/01/2023

Step	percent	Apprentice Base Wage	Health	Pension	Supplemental Unemployment	Total Rate
1	42	\$23.94	\$14.11	\$6.13	\$0.00	\$44.18
2	42	\$23.94	\$14.11	\$6.13	\$0.00	\$44.18
3	47	\$26.79	\$14.11	\$11.90	\$1.58	\$54.38
4	47	\$26.79	\$14.11	\$11.90	\$1.58	\$54.38
5	52	\$29.65	\$14.11	\$12.88	\$1.70	\$58.34
6	52	\$29.65	\$14.11	\$13.13	\$1.70	\$58.59
7	60	\$34.21	\$14.11	\$14.54	\$1.89	\$64.75
8	65	\$37.06	\$14.11	\$15.52	\$2.00	\$68.69
9	75	\$42.76	\$14.11	\$17.48	\$2.23	\$76.58
10	85	\$48.46	\$14.11	\$18.94	\$2.45	\$83.96

Notes:
Steps are 6 mos.

Apprentice to Journeyworker Ratio:1:4

SPECIALIZED EARTH MOVING EQUIP < 35 TONS <i>TEAMSTERS JOINT COUNCIL NO. 10 ZONE A</i>	12/01/2021	\$37.34	\$13.41	\$16.01	\$0.00	\$66.76
SPECIALIZED EARTH MOVING EQUIP > 35 TONS <i>TEAMSTERS JOINT COUNCIL NO. 10 ZONE A</i>	12/01/2021	\$37.63	\$13.41	\$16.01	\$0.00	\$67.05
SPRINKLER FITTER <i>SPRINKLER FITTERS LOCAL 550 - (Section A) Zone 1</i>	03/01/2023	\$66.20	\$10.90	\$23.20	\$0.00	\$100.30
	10/01/2023	\$67.95	\$10.90	\$23.20	\$0.00	\$102.05
	03/01/2024	\$69.75	\$10.90	\$23.20	\$0.00	\$103.85
	10/01/2024	\$71.55	\$10.90	\$23.20	\$0.00	\$105.65
	03/01/2025	\$73.35	\$10.90	\$23.20	\$0.00	\$107.45

Apprentice - SPRINKLER FITTER - Local 550 (Section A) Zone 1

Effective Date - 03/01/2023

Step	percent	Apprentice Base Wage	Health	Pension	Supplemental Unemployment	Total Rate
1	35	\$23.17	\$10.90	\$9.70	\$0.00	\$43.77
2	40	\$26.48	\$10.90	\$9.70	\$0.00	\$47.08
3	45	\$29.79	\$10.90	\$9.70	\$0.00	\$50.39
4	50	\$33.10	\$10.90	\$9.70	\$0.00	\$53.70
5	55	\$36.41	\$10.90	\$9.70	\$0.00	\$57.01
6	60	\$39.72	\$10.90	\$11.20	\$0.00	\$61.82
7	65	\$43.03	\$10.90	\$11.20	\$0.00	\$65.13
8	70	\$46.34	\$10.90	\$11.20	\$0.00	\$68.44
9	75	\$49.65	\$10.90	\$11.20	\$0.00	\$71.75
10	80	\$52.96	\$10.90	\$11.20	\$0.00	\$75.06

Effective Date - 10/01/2023

Step	percent	Apprentice Base Wage	Health	Pension	Supplemental Unemployment	Total Rate
1	35	\$23.78	\$10.90	\$9.70	\$0.00	\$44.38
2	40	\$27.18	\$10.90	\$9.70	\$0.00	\$47.78
3	45	\$30.58	\$10.90	\$9.70	\$0.00	\$51.18
4	50	\$33.98	\$10.90	\$9.70	\$0.00	\$54.58
5	55	\$37.37	\$10.90	\$9.70	\$0.00	\$57.97
6	60	\$40.77	\$10.90	\$11.20	\$0.00	\$62.87
7	65	\$44.17	\$10.90	\$11.20	\$0.00	\$66.27
8	70	\$47.57	\$10.90	\$11.20	\$0.00	\$69.67
9	75	\$50.96	\$10.90	\$11.20	\$0.00	\$73.06
10	80	\$54.36	\$10.90	\$11.20	\$0.00	\$76.46

Notes: Apprentice entered prior 9/30/10:
40/45/50/55/60/65/70/75/80/85
Steps are 850 hours

Apprentice to Journeyworker Ratio:1:3

STEAM BOILER OPERATOR	12/01/2022	\$53.05	\$14.25	\$16.05	\$0.00	\$83.35
OPERATING ENGINEERS LOCAL 4	06/01/2023	\$54.29	\$14.25	\$16.05	\$0.00	\$84.59
	12/01/2023	\$55.53	\$14.25	\$16.05	\$0.00	\$85.83
	06/01/2024	\$56.81	\$14.25	\$16.05	\$0.00	\$87.11
	12/01/2024	\$58.25	\$14.25	\$16.05	\$0.00	\$88.55
	06/01/2025	\$59.53	\$14.25	\$16.05	\$0.00	\$89.83
	12/01/2025	\$60.97	\$14.25	\$16.05	\$0.00	\$91.27
	06/01/2026	\$62.25	\$14.25	\$16.05	\$0.00	\$92.55
	12/01/2026	\$63.69	\$14.25	\$16.05	\$0.00	\$93.99

For apprentice rates see "Apprentice- OPERATING ENGINEERS"

Classification	Effective Date	Base Wage	Health	Pension	Supplemental Unemployment	Total Rate
TAMPERS, SELF-PROPELLED OR TRACTOR DRAWN <i>OPERATING ENGINEERS LOCAL 4</i>	12/01/2022	\$53.05	\$14.25	\$16.05	\$0.00	\$83.35
	06/01/2023	\$54.29	\$14.25	\$16.05	\$0.00	\$84.59
	12/01/2023	\$55.53	\$14.25	\$16.05	\$0.00	\$85.83
	06/01/2024	\$56.81	\$14.25	\$16.05	\$0.00	\$87.11
	12/01/2024	\$58.25	\$14.25	\$16.05	\$0.00	\$88.55
	06/01/2025	\$59.53	\$14.25	\$16.05	\$0.00	\$89.83
	12/01/2025	\$60.97	\$14.25	\$16.05	\$0.00	\$91.27
	06/01/2026	\$62.25	\$14.25	\$16.05	\$0.00	\$92.55
	12/01/2026	\$63.69	\$14.25	\$16.05	\$0.00	\$93.99

For apprentice rates see "Apprentice- OPERATING ENGINEERS"

TELECOMMUNICATION TECHNICIAN <i>ELECTRICIANS LOCAL 103</i>	03/01/2023	\$48.34	\$13.00	\$19.01	\$0.00	\$80.35
---	------------	---------	---------	---------	--------	---------

Apprentice - TELECOMMUNICATION TECHNICIAN - Local 103

Effective Date - 03/01/2023

Step	percent	Apprentice Base Wage	Health	Pension	Supplemental Unemployment	Total Rate
1	45	\$21.75	\$13.00	\$0.65	\$0.00	\$35.40
2	45	\$21.75	\$13.00	\$0.65	\$0.00	\$35.40
3	50	\$24.17	\$13.00	\$15.20	\$0.00	\$52.37
4	50	\$24.17	\$13.00	\$15.20	\$0.00	\$52.37
5	55	\$26.59	\$13.00	\$15.58	\$0.00	\$55.17
6	60	\$29.00	\$13.00	\$15.96	\$0.00	\$57.96
7	65	\$31.42	\$13.00	\$16.34	\$0.00	\$60.76
8	70	\$33.84	\$13.00	\$16.73	\$0.00	\$63.57
9	75	\$36.26	\$13.00	\$17.11	\$0.00	\$66.37
10	80	\$38.67	\$13.00	\$17.48	\$0.00	\$69.15

Notes:

Apprentice to Journeyworker Ratio:1:1

TERRAZZO FINISHERS <i>BRICKLAYERS LOCAL 3 - MARBLE & TILE</i>	02/01/2023	\$59.29	\$11.49	\$22.34	\$0.00	\$93.12
	08/01/2023	\$61.34	\$11.49	\$22.34	\$0.00	\$95.17
	02/01/2024	\$62.59	\$11.49	\$22.34	\$0.00	\$96.42
	08/01/2024	\$64.69	\$11.49	\$22.34	\$0.00	\$98.52
	02/01/2025	\$65.99	\$11.49	\$22.34	\$0.00	\$99.82
	08/01/2025	\$68.14	\$11.49	\$22.34	\$0.00	\$101.97
	02/01/2026	\$69.49	\$11.49	\$22.34	\$0.00	\$103.32
	08/01/2026	\$71.69	\$11.49	\$22.34	\$0.00	\$105.52
	02/01/2027	\$73.09	\$11.49	\$22.34	\$0.00	\$106.92

Classification

Effective Date Base Wage Health Pension Supplemental Unemployment Total Rate

Apprentice - TERRAZZO FINISHER - Local 3 Marble & Tile

Effective Date - 02/01/2023

Step	percent	Apprentice Base Wage	Health	Pension	Supplemental Unemployment	Total Rate
1	50	\$29.65	\$11.49	\$22.34	\$0.00	\$63.48
2	60	\$35.57	\$11.49	\$22.34	\$0.00	\$69.40
3	70	\$41.50	\$11.49	\$22.34	\$0.00	\$75.33
4	80	\$47.43	\$11.49	\$22.34	\$0.00	\$81.26
5	90	\$53.36	\$11.49	\$22.34	\$0.00	\$87.19

Effective Date - 08/01/2023

Step	percent	Apprentice Base Wage	Health	Pension	Supplemental Unemployment	Total Rate
1	50	\$30.67	\$11.49	\$22.34	\$0.00	\$64.50
2	60	\$36.80	\$11.49	\$22.34	\$0.00	\$70.63
3	70	\$42.94	\$11.49	\$22.34	\$0.00	\$76.77
4	80	\$49.07	\$11.49	\$22.34	\$0.00	\$82.90
5	90	\$55.21	\$11.49	\$22.34	\$0.00	\$89.04

Notes:

Apprentice to Journeyworker Ratio:1:3

TEST BORING DRILLER <i>LABORERS - FOUNDATION AND MARINE</i>	12/01/2022	\$46.58	\$9.35	\$17.97	\$0.00	\$73.90
	06/01/2023	\$47.58	\$9.35	\$17.97	\$0.00	\$74.90
	12/01/2023	\$48.83	\$9.35	\$17.97	\$0.00	\$76.15
	06/01/2024	\$50.31	\$9.35	\$17.97	\$0.00	\$77.63
	12/01/2024	\$51.78	\$9.35	\$17.97	\$0.00	\$79.10
	06/01/2025	\$53.28	\$9.35	\$17.97	\$0.00	\$80.60
	12/01/2025	\$54.78	\$9.35	\$17.97	\$0.00	\$82.10
	06/01/2026	\$56.33	\$9.35	\$17.97	\$0.00	\$83.65
	12/01/2026	\$57.83	\$9.35	\$17.97	\$0.00	\$85.15

For apprentice rates see "Apprentice- LABORER"

TEST BORING DRILLER HELPER <i>LABORERS - FOUNDATION AND MARINE</i>	12/01/2022	\$42.70	\$9.35	\$17.97	\$0.00	\$70.02
	06/01/2023	\$43.70	\$9.35	\$17.97	\$0.00	\$71.02
	12/01/2023	\$44.95	\$9.35	\$17.97	\$0.00	\$72.27
	06/01/2024	\$46.43	\$9.35	\$17.97	\$0.00	\$73.75
	12/01/2024	\$47.90	\$9.35	\$17.97	\$0.00	\$75.22
	06/01/2025	\$49.40	\$9.35	\$17.97	\$0.00	\$76.72
	12/01/2025	\$50.90	\$9.35	\$17.97	\$0.00	\$78.22
	06/01/2026	\$52.45	\$9.35	\$17.97	\$0.00	\$79.77
	12/01/2026	\$53.95	\$9.35	\$17.97	\$0.00	\$81.27

For apprentice rates see "Apprentice- LABORER"

Classification	Effective Date	Base Wage	Health	Pension	Supplemental Unemployment	Total Rate
TEST BORING LABORER <i>LABORERS - FOUNDATION AND MARINE</i>	12/01/2022	\$42.58	\$9.35	\$17.97	\$0.00	\$69.90
	06/01/2023	\$43.58	\$9.35	\$17.97	\$0.00	\$70.90
	12/01/2023	\$44.83	\$9.35	\$17.97	\$0.00	\$72.15
	06/01/2024	\$46.31	\$9.35	\$17.97	\$0.00	\$73.63
	12/01/2024	\$47.78	\$9.35	\$17.97	\$0.00	\$75.10
	06/01/2025	\$49.28	\$9.35	\$17.97	\$0.00	\$76.60
	12/01/2025	\$50.78	\$9.35	\$17.97	\$0.00	\$78.10
	06/01/2026	\$52.33	\$9.35	\$17.97	\$0.00	\$79.65
	12/01/2026	\$53.83	\$9.35	\$17.97	\$0.00	\$81.15
For apprentice rates see "Apprentice- LABORER"						
TRACTORS/PORTABLE STEAM GENERATORS <i>OPERATING ENGINEERS LOCAL 4</i>	12/01/2022	\$53.05	\$14.25	\$16.05	\$0.00	\$83.35
	06/01/2023	\$54.29	\$14.25	\$16.05	\$0.00	\$84.59
	12/01/2023	\$55.53	\$14.25	\$16.05	\$0.00	\$85.83
	06/01/2024	\$56.81	\$14.25	\$16.05	\$0.00	\$87.11
	12/01/2024	\$58.25	\$14.25	\$16.05	\$0.00	\$88.55
	06/01/2025	\$59.53	\$14.25	\$16.05	\$0.00	\$89.83
	12/01/2025	\$60.97	\$14.25	\$16.05	\$0.00	\$91.27
	06/01/2026	\$62.25	\$14.25	\$16.05	\$0.00	\$92.55
	12/01/2026	\$63.69	\$14.25	\$16.05	\$0.00	\$93.99
For apprentice rates see "Apprentice- OPERATING ENGINEERS"						
TRAILERS FOR EARTH MOVING EQUIPMENT <i>TEAMSTERS JOINT COUNCIL NO. 10 ZONE A</i>	12/01/2021	\$37.92	\$13.41	\$16.01	\$0.00	\$67.34
TUNNEL WORK - COMPRESSED AIR <i>LABORERS (COMPRESSED AIR)</i>	12/01/2022	\$54.81	\$9.35	\$18.42	\$0.00	\$82.58
	06/01/2023	\$55.81	\$9.35	\$18.42	\$0.00	\$83.58
	12/01/2023	\$57.06	\$9.35	\$18.42	\$0.00	\$84.83
	06/01/2024	\$58.54	\$9.35	\$18.42	\$0.00	\$86.31
	12/01/2024	\$60.01	\$9.35	\$18.42	\$0.00	\$87.78
	06/01/2025	\$61.51	\$9.35	\$18.42	\$0.00	\$89.28
	12/01/2025	\$63.01	\$9.35	\$18.42	\$0.00	\$90.78
	06/01/2026	\$64.56	\$9.35	\$18.42	\$0.00	\$92.33
	12/01/2026	\$66.06	\$9.35	\$18.42	\$0.00	\$93.83
For apprentice rates see "Apprentice- LABORER"						
TUNNEL WORK - COMPRESSED AIR (HAZ. WASTE) <i>LABORERS (COMPRESSED AIR)</i>	12/01/2022	\$56.81	\$9.35	\$18.42	\$0.00	\$84.58
	06/01/2023	\$57.81	\$9.35	\$18.42	\$0.00	\$85.58
	12/01/2023	\$59.06	\$9.35	\$18.42	\$0.00	\$86.83
	06/01/2024	\$60.54	\$9.35	\$18.42	\$0.00	\$88.31
	12/01/2024	\$62.01	\$9.35	\$18.42	\$0.00	\$89.78
	06/01/2025	\$63.51	\$9.35	\$18.42	\$0.00	\$91.28
	12/01/2025	\$65.01	\$9.35	\$18.42	\$0.00	\$92.78
	06/01/2026	\$66.56	\$9.35	\$18.42	\$0.00	\$94.33
	12/01/2026	\$68.06	\$9.35	\$18.42	\$0.00	\$95.83
For apprentice rates see "Apprentice- LABORER"						

Classification	Effective Date	Base Wage	Health	Pension	Supplemental Unemployment	Total Rate
TUNNEL WORK - FREE AIR <i>LABORERS (FREE AIR TUNNEL)</i>	12/01/2022	\$46.88	\$9.35	\$18.42	\$0.00	\$74.65
	06/01/2023	\$47.88	\$9.35	\$18.42	\$0.00	\$75.65
	12/01/2023	\$49.13	\$9.35	\$18.42	\$0.00	\$76.90
	06/01/2024	\$50.61	\$9.35	\$18.42	\$0.00	\$78.38
	12/01/2024	\$52.08	\$9.35	\$18.42	\$0.00	\$79.85
	06/01/2025	\$53.58	\$9.35	\$18.42	\$0.00	\$81.35
	12/01/2025	\$55.08	\$9.35	\$18.42	\$0.00	\$82.85
	06/01/2026	\$56.63	\$9.35	\$18.42	\$0.00	\$84.40
	12/01/2026	\$58.13	\$9.35	\$18.42	\$0.00	\$85.90
For apprentice rates see "Apprentice- LABORER"						
TUNNEL WORK - FREE AIR (HAZ. WASTE) <i>LABORERS (FREE AIR TUNNEL)</i>	12/01/2022	\$48.88	\$9.35	\$18.42	\$0.00	\$76.65
	06/01/2023	\$49.88	\$9.35	\$18.42	\$0.00	\$77.65
	12/01/2023	\$51.13	\$9.35	\$18.42	\$0.00	\$78.90
	06/01/2024	\$52.61	\$9.35	\$18.42	\$0.00	\$80.38
	12/01/2024	\$54.08	\$9.35	\$18.42	\$0.00	\$81.85
	06/01/2025	\$55.58	\$9.35	\$18.42	\$0.00	\$83.35
	12/01/2025	\$57.08	\$9.35	\$18.42	\$0.00	\$84.85
	06/01/2026	\$58.63	\$9.35	\$18.42	\$0.00	\$86.40
	12/01/2026	\$60.13	\$9.35	\$18.42	\$0.00	\$87.90
For apprentice rates see "Apprentice- LABORER"						
VAC-HAUL <i>TEAMSTERS JOINT COUNCIL NO. 10 ZONE A</i>	12/01/2021	\$37.34	\$13.41	\$16.01	\$0.00	\$66.76
WAGON DRILL OPERATOR <i>LABORERS - ZONE 1</i>	12/01/2022	\$43.43	\$9.10	\$17.57	\$0.00	\$70.10
	06/01/2023	\$44.43	\$9.10	\$17.57	\$0.00	\$71.10
	12/01/2023	\$45.68	\$9.10	\$17.57	\$0.00	\$72.35
For apprentice rates see "Apprentice- LABORER"						
WAGON DRILL OPERATOR (HEAVY & HIGHWAY) <i>LABORERS - ZONE 1 (HEAVY & HIGHWAY)</i>	12/01/2022	\$42.83	\$9.35	\$17.82	\$0.00	\$70.00
	06/01/2023	\$43.83	\$9.35	\$17.82	\$0.00	\$71.00
	12/01/2023	\$45.08	\$9.35	\$17.82	\$0.00	\$72.25
	06/01/2024	\$46.56	\$9.35	\$17.82	\$0.00	\$73.73
	12/01/2024	\$48.03	\$9.35	\$17.82	\$0.00	\$75.20
	06/01/2025	\$49.53	\$9.35	\$17.82	\$0.00	\$76.70
	12/01/2025	\$51.03	\$9.35	\$17.82	\$0.00	\$78.20
	06/01/2026	\$52.58	\$9.35	\$17.82	\$0.00	\$79.75
	12/01/2026	\$54.08	\$9.35	\$17.82	\$0.00	\$81.25
For apprentice rates see "Apprentice- LABORER (Heavy and Highway)"						
WASTE WATER PUMP OPERATOR <i>OPERATING ENGINEERS LOCAL 4</i>	12/01/2022	\$53.63	\$14.25	\$16.05	\$0.00	\$83.93
	06/01/2023	\$54.88	\$14.25	\$16.05	\$0.00	\$85.18
	12/01/2023	\$56.13	\$14.25	\$16.05	\$0.00	\$86.43
	06/01/2024	\$57.43	\$14.25	\$16.05	\$0.00	\$87.73
	12/01/2024	\$58.88	\$14.25	\$16.05	\$0.00	\$89.18
	06/01/2025	\$60.18	\$14.25	\$16.05	\$0.00	\$90.48
	12/01/2025	\$61.63	\$14.25	\$16.05	\$0.00	\$91.93
	06/01/2026	\$62.93	\$14.25	\$16.05	\$0.00	\$93.23
	12/01/2026	\$64.38	\$14.25	\$16.05	\$0.00	\$94.68
For apprentice rates see "Apprentice- OPERATING ENGINEERS"						

Classification	Effective Date	Base Wage	Health	Pension	Supplemental Unemployment	Total Rate
WATER METER INSTALLER <i>PLUMBERS & GASFITTERS LOCAL 12</i>	02/26/2023	\$65.19	\$14.07	\$18.36	\$0.00	\$97.62
	09/03/2023	\$66.94	\$14.07	\$18.36	\$0.00	\$99.37
	03/03/2024	\$68.74	\$14.07	\$18.36	\$0.00	\$101.17
	09/01/2024	\$70.54	\$14.07	\$18.36	\$0.00	\$102.97
	03/02/2025	\$72.34	\$14.07	\$18.36	\$0.00	\$104.77
For apprentice rates see "Apprentice- PLUMBER/PIPEFITTER" or "PLUMBER/GASFITTER"						
Outside Electrical - East						
CABLE TECHNICIAN (Power Zone) <i>OUTSIDE ELECTRICAL WORKERS - EAST LOCAL 104</i>	08/30/2020	\$29.67	\$9.25	\$1.89	\$0.00	\$40.81
For apprentice rates see "Apprentice- LINEMAN"						
CABLEMAN (Underground Ducts & Cables) <i>OUTSIDE ELECTRICAL WORKERS - EAST LOCAL 104</i>	08/30/2020	\$42.03	\$9.25	\$10.27	\$0.00	\$61.55
For apprentice rates see "Apprentice- LINEMAN"						
DRIVER / GROUNDMAN CDL <i>OUTSIDE ELECTRICAL WORKERS - EAST LOCAL 104</i>	08/30/2020	\$34.62	\$9.25	\$10.07	\$0.00	\$53.94
For apprentice rates see "Apprentice- LINEMAN"						
DRIVER / GROUNDMAN -Inexperienced (<2000 Hrs) <i>OUTSIDE ELECTRICAL WORKERS - EAST LOCAL 104</i>	08/30/2020	\$27.20	\$9.25	\$1.82	\$0.00	\$38.27
For apprentice rates see "Apprentice- LINEMAN"						
EQUIPMENT OPERATOR (Class A CDL) <i>OUTSIDE ELECTRICAL WORKERS - EAST LOCAL 104</i>	08/30/2020	\$42.03	\$9.25	\$14.35	\$0.00	\$65.63
For apprentice rates see "Apprentice- LINEMAN"						
EQUIPMENT OPERATOR (Class B CDL) <i>OUTSIDE ELECTRICAL WORKERS - EAST LOCAL 104</i>	08/30/2020	\$37.09	\$9.25	\$10.87	\$0.00	\$57.21
For apprentice rates see "Apprentice- LINEMAN"						
GROUNDMAN <i>OUTSIDE ELECTRICAL WORKERS - EAST LOCAL 104</i>	08/30/2020	\$27.20	\$9.25	\$1.82	\$0.00	\$38.27
For apprentice rates see "Apprentice- LINEMAN"						
GROUNDMAN -Inexperienced (<2000 Hrs.) <i>OUTSIDE ELECTRICAL WORKERS - EAST LOCAL 104</i>	08/30/2020	\$22.25	\$9.25	\$1.82	\$0.00	\$33.32
For apprentice rates see "Apprentice- LINEMAN"						
JOURNEYMAN LINEMAN <i>OUTSIDE ELECTRICAL WORKERS - EAST LOCAL 104</i>	08/30/2020	\$49.45	\$9.25	\$17.48	\$0.00	\$76.18

Apprentice - LINEMAN (Outside Electrical) - East Local 104

Effective Date - 08/30/2020

Step	percent	Apprentice Base Wage	Health	Pension	Supplemental Unemployment	Total Rate
1	60	\$29.67	\$9.25	\$3.39	\$0.00	\$42.31
2	65	\$32.14	\$9.25	\$3.46	\$0.00	\$44.85
3	70	\$34.62	\$9.25	\$3.54	\$0.00	\$47.41
4	75	\$37.09	\$9.25	\$5.11	\$0.00	\$51.45
5	80	\$39.56	\$9.25	\$5.19	\$0.00	\$54.00
6	85	\$42.03	\$9.25	\$5.26	\$0.00	\$56.54
7	90	\$44.51	\$9.25	\$7.34	\$0.00	\$61.10

Notes:

Apprentice to Journeyworker Ratio:1:2

Classification	Effective Date	Base Wage	Health	Pension	Supplemental Unemployment	Total Rate
TELEDATA CABLE SPLICER <i>OUTSIDE ELECTRICAL WORKERS - EAST LOCAL 104</i>	02/04/2019	\$30.73	\$4.70	\$3.17	\$0.00	\$38.60
TELEDATA LINEMAN/EQUIPMENT OPERATOR <i>OUTSIDE ELECTRICAL WORKERS - EAST LOCAL 104</i>	02/04/2019	\$28.93	\$4.70	\$3.14	\$0.00	\$36.77
TELEDATA WIREMAN/INSTALLER/TECHNICIAN <i>OUTSIDE ELECTRICAL WORKERS - EAST LOCAL 104</i>	02/04/2019	\$28.93	\$4.70	\$3.14	\$0.00	\$36.77

Additional Apprentice Information:

Minimum wage rates for apprentices employed on public works projects are listed above as a percentage of the pre-determined hourly wage rate established by the Commissioner under the provisions of the M.G.L. c. 149, ss. 26-27D. Apprentice ratios are established by the Division of Apprenticeship Training pursuant to M.G.L. c. 23, ss. 11E-11L.

All apprentices must be registered with the Division of Apprenticeship Training in accordance with M.G.L. c. 23, ss. 11E-11L.

All steps are six months (1000 hours.)

Ratios are expressed in allowable number of apprentices to journeymen or fraction thereof, unless otherwise specified.

** Multiple ratios are listed in the comment field.

*** APP to JM; 1:1, 2:2, 2:3, 3:4, 4:4, 4:5, 4:6, 5:7, 6:7, 6:8, 6:9, 7:10, 8:10, 8:11, 8:12, 9:13, 10:13, 10:14, etc.

**** APP to JM; 1:1, 1:2, 2:3, 2:4, 3:5, 4:6, 4:7, 5:8, 6:9, 6:10, 7:11, 8:12, 8:13, 9:14, 10:15, 10:16, etc.