

Arlington High School Building Committee

Meeting Date: Tuesday, April 2nd, 2024, 6:00 p.m.
Location: Conducted via Remote Participation

- ❖ Skanska Update
 - ◆ Consigli Change Order # 38
 - ◆ Conservation Commission Update

- ❖ Consigli Update
 - ◆ Schedule Update

- ❖ Subcommittee Reports
 - ◆ Communications
 - ◆ Finance
 - ◆ Interiors
 - ◆ Landscape & Exteriors
 - ◆ Memorials
 - ◆ SMEFPF
 - ◆ Security
 - ◆ Temp Use-Phasing

- ❖ Meeting Minute Approval
 - ◆ March 5, 2024

- ❖ New Business

- ❖ Adjournment

The listings of matters are those reasonably anticipated by the Chair which may be discussed at the meeting. Not all items listed may in fact be discussed and other items not listed may also be brought up for discussion to the extent permitted by law.

Members of the public are asked to send written comment to kfitzgerald@arlington.k12.ma.us. Documents regarding agenda items will be made available via the Town's website.

<https://www.mass.gov/doc/open-meeting-law-order-march-12-2020/download>

Join Zoom Meeting
<https://town-arlington-ma-us.zoom.us/j/89551871411>

Meeting ID: 895 5187 1411

Passcode: 360185

One tap mobile

+13126266799,,89551871411# US (Chicago)

+16468769923,,89551871411# US (New York)

Dial by your location

+1 312 626 6799 US (Chicago)

+1 646 876 9923 US (New York)

+1 646 931 3860 US

+1 301 715 8592 US (Washington DC)

+1 669 444 9171 US

+1 669 900 6833 US (San Jose)

+1 253 215 8782 US (Tacoma)

+1 346 248 7799 US (Houston)

+1 386 347 5053 US

+1 408 638 0968 US (San Jose)

+1 564 217 2000 US

Meeting ID: 895 5187 1411

Find your local number: <https://town-arlington-ma-us.zoom.us/j/kjyoLwXIQ>

Arlington High School Building Committee

Meeting Materials Package – 4/2/2024

Table of Contents

- Agenda – page 1
- Table of Contents / Vote Language – page 3
- Consigli Change Order #38 – page 4
- Consigli Monthly Owner’s Dashboard and photos– page 34
- AHSBC Draft Meeting Minutes 3/5/2024 – page 39

Vote Language

- Motion to approve Consigli Change Order #38 in the amount of \$111,866.10.
- Motion to approve the 3/5/24 AHSBC Meeting Minutes.



Change Order (CO)		NO: 38
Date of Issuance:	06-March 2024	

Project:	Arlingth High School	Contract For:	New Construction
Address:	869 Massachusetts Avenue, Arlington MA	Contract Date:	June 26, 2019
Owner:	Town of Arlington		
Address:	730 Massachusetts Avenue Arlington, MA 02476	Project ID:	
From:	HMFH Architects, Inc	To:	Consigli Construction Co., Inc.
Address:	130 Bishop Allen Drive, Cambridge MA 02139	Address:	72 Summer Street, Milford MA

Items included in this Change Order:	Cost:
CR 606.1R PR-022 Provide site lights along Bike Ramp.	\$ 106,082.95
CR 747 CCD-055 Provide two additional lighted exit signs in Auditorium.	\$ 5,783.15

Change Order Total: \$ 111,866.10

THE CONTRACT IS CHANGED AS FOLLOWS:	
Original Contract Sum was:	\$234,287,347.00
Net change by previously authorized Change Order was:	\$ 3,664,681.33
Contract Sum prior to this Change Order was:	\$237,952,028.33
Contract Sum will be (increased) (decreased) by Change Order in the amount of:	\$ 111,866.10
New Contract Sum including this Change Order will be:	\$238,063,894.43
Contract Time will unchanged .	
Date of Substantial Completion as of the date of this Change Order therefore is:	02/14/2022 (Phase 1) 10/30/2023 (Phase 2) 12/16/2024 (Phase 3) 09/26/2025 (Final-Site)

NOTE: This Change Order does not include changes in the Contract Sum, Contract Time or Guaranteed Maximum Price, which have been authorized by Construction Change Directive until the cost and time have been agreed upon by both the Owner and Contractor, in which case a Change Order is executed to supersede the Construction Change Directive.
NOT VALID UNTIL SIGNED BY THE ARCHITECT, CONTRACTOR AND OWNER.

Architect HMFH Architects, Inc. 130 Bishop Allen Drive. Cambridge, MA	Owner's Project Manager Skanska USA Building, Inc. 101 Seaport Boulevard, Suite 200 Boston, MA 02210	Construction Manager Consigli Construction Co., Inc. 72 Summer Street Milford, MA 01757
		
BY (Signature) Arthur Duffy	BY (Signature) Jim Burrows	BY (Signature) John LaMarre
03/15/2024		
Date	Date	Date

Town Manager James Feeney 730 Massachusetts, Avenue Arlington MA, 02476		
BY (Signature) James Feeney	BY (Signature)	BY (Signature)
Date	Date	Date

Attachments:	CR's 606.1R, 747	
Distribution:	<input checked="" type="checkbox"/> Owner – James Feeney	<input checked="" type="checkbox"/> Architect – Arthur Duffy, Lori Cowles HMFH Architects, Inc.
	<input checked="" type="checkbox"/> OPM – Jim Burrows, Sy Nguyen, Hal Raymond, Victoria Clifford Skanska USA Building, Inc.	<input checked="" type="checkbox"/> Contractor – John LaMarre, Todd McCabe, Chris Weber, Consigli Construction Co., Inc.
	<input checked="" type="checkbox"/> Field – T. DeRosa Consigli Construction Co, Inc.	<input type="checkbox"/> Other-



Change Request

To: Jim Burrows
 Skanska USA Building Inc.
 253 Summer Street
 Boston, MA 02210
 Ph: 617-574-1524 Fax: 617-574-1399

Number: CR606.1
Date: 5/2/23
Job: 2153 Arlington High School
Phone:

Description: PR-022 - Addition of Lighting Along Bikepath Connector Ramp - OPTION 2_Sub.050123

Source: PR # 022

We offer the following specifications and pricing to make the changes as described below:

CR606.1 includes costs associated with PR-022 - Addition of Lighting Along Bikepath Connector Ramp - Option 2 dated 3/30/23 issued by HMFH. Scope of work associated with Option 2 includes WJGEI pricing to F&I (10) PT02 fixtures and associated branch circuitry, furnish only associated precast light pole bases, and J. Derenzo pricing for excavation/backfill associated with UG conduit, light pole bases, and setting of bases. Please see attached pricing and associated backup for additional information.

Assumptions & Qualifications:

- Costs associated with overtime/acceleration are not included
- CR606.1 includes PR-022 pricing for Option 2 only. Option 1 pricing has been submitted under CR606.
- CR606.1 pricing assumes all associated scope is within current limits of work of the project. Costs associated with grading/sitework beyond limits of work are not included and will be determined upon final issuance of civil drawings.
- Costs associated with disposal of contaminated soils is not included
- CCC will not proceed with this scope until approval and direction to proceed is issued
- Schedule impact associated with PR-022 will be determined (if any) upon approval of CR606.1 and release of fixtures. Current lead time for fixtures is approx. 24 weeks from approval.
- CR606.1 pricing is valid for 30 days from 2/20/24.

Description	Labor	Material	Equipment	Subcontract	Other	Price
WJGEI - Proposal #310 dated 2/20/24				\$90,183.17		\$90,183.17
J. Derenzo - PCO-18 dated 4/4/23 - Option 2				\$8,795.00		\$8,795.00
					Subtotal:	\$98,978.17
			Bond (.75%)	\$98,978.17		\$742.34
			General Liability (1.2%)	\$98,978.17		\$1,187.74
			Subguard (1.4%)	\$8,795.00		\$123.13
			OH&P (5% subs, 10% self perform)	\$101,031.38		\$5,051.57
					Total:	\$106,082.95

- SCHEDULE IMPACT
- We have proceeded with this change to achieve schedule.
- As directed, we will not proceed with this change until formal direction from OWNER is received.



Change Request

To: Jim Burrows
 Skanska USA Building Inc.
 253 Summer Street
 Boston, MA 02210
 Ph: 617-574-1524 Fax: 617-574-1399

Number: CR606.1
Date: 5/2/23
Job: 2153 Arlington High School
Phone:

ARCHITECT

Consigli Construction Co., Inc.
 CONTRACTOR
 72 Sumner Street
 Milford, MA 01757

OWNER

(Signature)

(Signature)

(Signature)

Arthur Duffy

John LaMarre

By

By

By

02/26/2024

2/21/24

Date

Date

Date



WAYNE J.
GRIFFIN ELECTRIC
INC.

February 20, 2024

VIA EMAIL ONLY: cweber@consigli.com

Mr. Chris Weber, Project Manager
Consigli Construction Company, Inc.
72 Sumner Street
Milford, MA 01757

RE: Job #2698 - Arlington High School, Arlington, MA
Proposal #310

Dear Mr. Weber:

Wayne J. Griffin Electric, Inc. ("WJGEI") proposes to modify our contract to perform the following lump sum revisions to our work per our enclosed detailed backup:

DESCRIPTION OF WORK:

As reflected under PR-22 "Option 2", provide additional lighting fixtures and associated branch circuitry for the lighting along the new bike path. Fixtures have a twenty-four (24) week lead time upon a release of an order. All excavation, backfill, and light pole base installation is by others.

Total \$ 90,183.17 ✓

This is a lump sum forward looking estimate of the above-noted change to our scope of work. This estimate represents a price we are willing to accept to assume the cost risk of this change to our ongoing work given the information provided to us. The labor and material prices contained in this proposal are based upon vendor/subcontractor quotes (if noted) and/or electrical industry pricing guides such as NECA, Trade Service, or R.S. Means, which guides are widely used and accepted in the construction industry to facilitate timely and consistent change order pricing. This estimate is offered for your review, approval and acceptance.

The value included in this proposal does not include any amounts for extended contract duration, overtime, changes in the sequence of work, acceleration, disruptions, interference and/or impacts, and the right is expressly reserved to recover any and all of these related items prior to any final settlement of this contract. The working relationship between your company and ours shall be in accordance with our mutually agreed to contract form.

Corporate Headquarters:

116 Hopping Brook Road
Holliston, MA 01746
Phone: (508) 429-8830
Fax: (508) 429-7825

Regional Offices:

296 Cahaba Valley Parkway
Pelham, AL 35124
Phone: (205) 733-8848
Fax: (205) 733-8107

2395 Pleasantdale Road
Suite 14
Doraville, GA 30340
Phone: (678) 417-9377
Fax: (678) 417-9373

2310 Presidential Drive
Suite 101
Durham, NC 27703
Phone: (919) 627-9724
Fax: (919) 627-9727

9801-C Southern Pine Boulevard
Charlotte, NC 28273
Phone: (704) 522-3851
Fax: (704) 522-3856

Wayne J. Griffin Electric, Inc. reserves the right to void this proposal after thirty (30) days from the date above.

If you have any questions regarding the above, please do not hesitate to contact me at (508) 306-5313 or wpease@wjgei.com.

Very truly yours,

WAYNE J. GRIFFIN ELECTRIC, INC.



Wayne A. Pease
Senior Project Manager

WP/bhd

ACKNOWLEDGMENT: The contract modifications stated for the above proposal are acceptable for the work to be performed. The value of the work completed to the date of the next requisition may be billed on that requisition.

Date: _____ Authorized Signature: _____

cc: John LaMarre, Senior Project Manager, Consigli Construction Company, Inc.,
JLaMarre@consigli.com
Jeremiah Kimball, Project Foreman, Wayne J. Griffin Electric, Inc.



CCN#: P-0310, PR-22 Option 2 Bike Path
 Date: 2/16/2024
 Project Name: Arlington High School
 Project Number: 02698-00-20
 Page Number: 1

116 Hopping Brook Road, Holliston, MA 01746
 (508) 429-8830 FAX (508) 429-9251

Work Description

As reflected under PR-22 "Option 2", provide additional lighting fixtures and associated branch circuitry for the lighting along the new bike path. Note fixtures have a 24-week lead time upon a release of an order. All excavation, backfill and light pole base installation is by others.

Itemized Breakdown

Description	Qty	Net Price	UM	Materials (\$)	Labor	Total Hours
Field Layout/Coordination	0.00	0.0000	HRS	0.000	0.000	8.380
Phase Totals				0.00		8.38
Fixture Type PT02-2	8.00	0.0000	E	0.000	2.960	23.680
Fixture Type PT02-3	2.00	0.0000	E	0.000	2.960	5.920
Fixture Quotation	1.00	34,950.0000	E	34,950.000	0.000	0.000
Precast Light Pole Bases	10.00	756.0000	E	7,560.000	0.000	0.000
Precast Hand Holes	3.00	555.0000	E	1,665.000	1.500	4.500
Freight (hand hole)	1.00	145.0000	E	145.000	0.000	0.000
Equipment Rental	1.00	2,500.0000	E	2,500.000	0.000	0.000
2" PVC Pipe	200.00	3.9300	E	786.000	0.044	8.800
2" PVC 90 Sweeps	6.00	5.4500	E	32.700	0.500	3.000
2" PVC Couplings	12.00	1.4300	E	17.160	0.440	5.280
1" PVC Pipe	50.00	1.9200	E	96.000	0.031	1.550
1" PVC 90 Sweeps	10.00	1.8400	E	18.400	0.250	2.500
1" PVC Adapters	10.00	0.7000	E	7.000	0.205	2.050
1" Rigid Conduit	50.00	7.8500	E	392.500	0.123	6.150
1" Rigid 90 Sweep	10.00	14.4000	E	144.000	0.333	3.330
1" Rigid Coupling	20.00	4.5700	E	91.400	0.060	1.200
1" Grounding Bushing	10.00	22.0000	E	220.000	0.400	4.000
PVC Cement	1.00	27.0000	E	27.000	0.000	0.000
#2 THHN Cu Wire	3,750.00	2.6400	E	9,900.000	0.018	67.500
#10 THHN Cu Wire	900.00	0.4800	E	432.000	0.008	7.200
#PBTO-1/0 Splices	30.00	34.2900	E	1,028.700	0.667	20.010
Wire Connectors	30.00	0.1900	E	5.700	0.030	0.900
Phase Totals				60,018.56		167.57
Totals				60,018.56		175.95
Tax				0.00		
Materials with Tax				60,018.56		

Summary

Itemized Breakdown Total		60,018.56	✓
Electrical Journeyman	(175.9500 hrs @ \$93.86 / hr)	16,514.67	
		16,514.67	✓
Labor Burden	(\$16,514.67 @ 30.00%)	4,954.40	✓
		4,954.40	✓
Overhead & Profit	(\$81,487.63 @ 10.00%)	8,148.76	✓
		8,148.76	✓
Bond	(\$89,636.39 @ 0.61%)	546.78	✓
		546.78	✓
		13,649.94	✓



CCN#: P-0310, PR-22 Option 2 Bike Path
Date: 2/16/2024
Project Name: Arlington High School
Project Number: 02698-00-20
Page Number: 2

116 Hopping Brook Road, Holliston, MA 01746
(508) 429-8830 FAX (508) 429-9251

Total

\$90,183.17





Project: ARLINGTON HIGH SCHOOL - 119209

Change Order - Quotation

Change Type	Quantity	Description	Unit or Lot#	Unit Price	Ext Price Change Amt						
✓ PT02-3-HS	2	EDR-8599-DC216FC-30-T3-530M-BLK-M OD-7P	AMERLUX								
		<table style="margin: auto; border-collapse: collapse;"> <tr> <td style="border-bottom: 1px solid black; padding: 2px;"><u>Prev Qty</u></td> <td style="border-bottom: 1px solid black; padding: 2px;"><u>Change Qty</u></td> <td style="border-bottom: 1px solid black; padding: 2px;"><u>New Qty</u></td> </tr> <tr> <td style="text-align: center; padding: 2px;">0</td> <td style="text-align: center; padding: 2px;">2</td> <td style="text-align: center; padding: 2px;">2</td> </tr> </table>	<u>Prev Qty</u>	<u>Change Qty</u>	<u>New Qty</u>	0	2	2			
<u>Prev Qty</u>	<u>Change Qty</u>	<u>New Qty</u>									
0	2	2									
		** Quantity changed from 0 to 2 **									
✓ PT02-3-HS	2	AP7204-14-BLK-LT	AMERLUX								
		<table style="margin: auto; border-collapse: collapse;"> <tr> <td style="border-bottom: 1px solid black; padding: 2px;"><u>Prev Qty</u></td> <td style="border-bottom: 1px solid black; padding: 2px;"><u>Change Qty</u></td> <td style="border-bottom: 1px solid black; padding: 2px;"><u>New Qty</u></td> </tr> <tr> <td style="text-align: center; padding: 2px;">0</td> <td style="text-align: center; padding: 2px;">2</td> <td style="text-align: center; padding: 2px;">2</td> </tr> </table>	<u>Prev Qty</u>	<u>Change Qty</u>	<u>New Qty</u>	0	2	2			
<u>Prev Qty</u>	<u>Change Qty</u>	<u>New Qty</u>									
0	2	2									
		** Quantity changed from 0 to 2 **									
✓ PT02-3-HS	2	AP7200-555-0018 3/4" x 17" anchor bolts, set of 4 Anchor bolts purchased separately (if required)	AMERLUX								
		<table style="margin: auto; border-collapse: collapse;"> <tr> <td style="border-bottom: 1px solid black; padding: 2px;"><u>Prev Qty</u></td> <td style="border-bottom: 1px solid black; padding: 2px;"><u>Change Qty</u></td> <td style="border-bottom: 1px solid black; padding: 2px;"><u>New Qty</u></td> </tr> <tr> <td style="text-align: center; padding: 2px;">0</td> <td style="text-align: center; padding: 2px;">2</td> <td style="text-align: center; padding: 2px;">2</td> </tr> </table>	<u>Prev Qty</u>	<u>Change Qty</u>	<u>New Qty</u>	0	2	2			
<u>Prev Qty</u>	<u>Change Qty</u>	<u>New Qty</u>									
0	2	2									
		** Quantity changed from 0 to 2 **									

Total	34950.00
--------------	-----------------

From:
 NORTHEAST ELECTRICAL
 SALES 978-374-4111
 560 OAK STREET
 BROCKTON, MA 02301
 Printed By: ALISON GERMAIN

Authorizing Name: ALISON GERMAIN
 File Number: 912
 ARLINGTON PR-022 BIKE PATH OPTION 2

These items are not ordered! To complete this order, sign below and provide a PO # for the order.

Signature: _____

TYPE
PT02-2 HS 2153 EDR-8599-DC216FC-30-T2-530M-BLK- BLS-MOD-7P
PART STRING
AP7204-14-BLK-LT

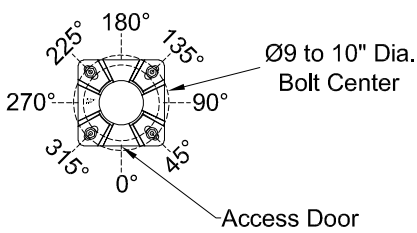
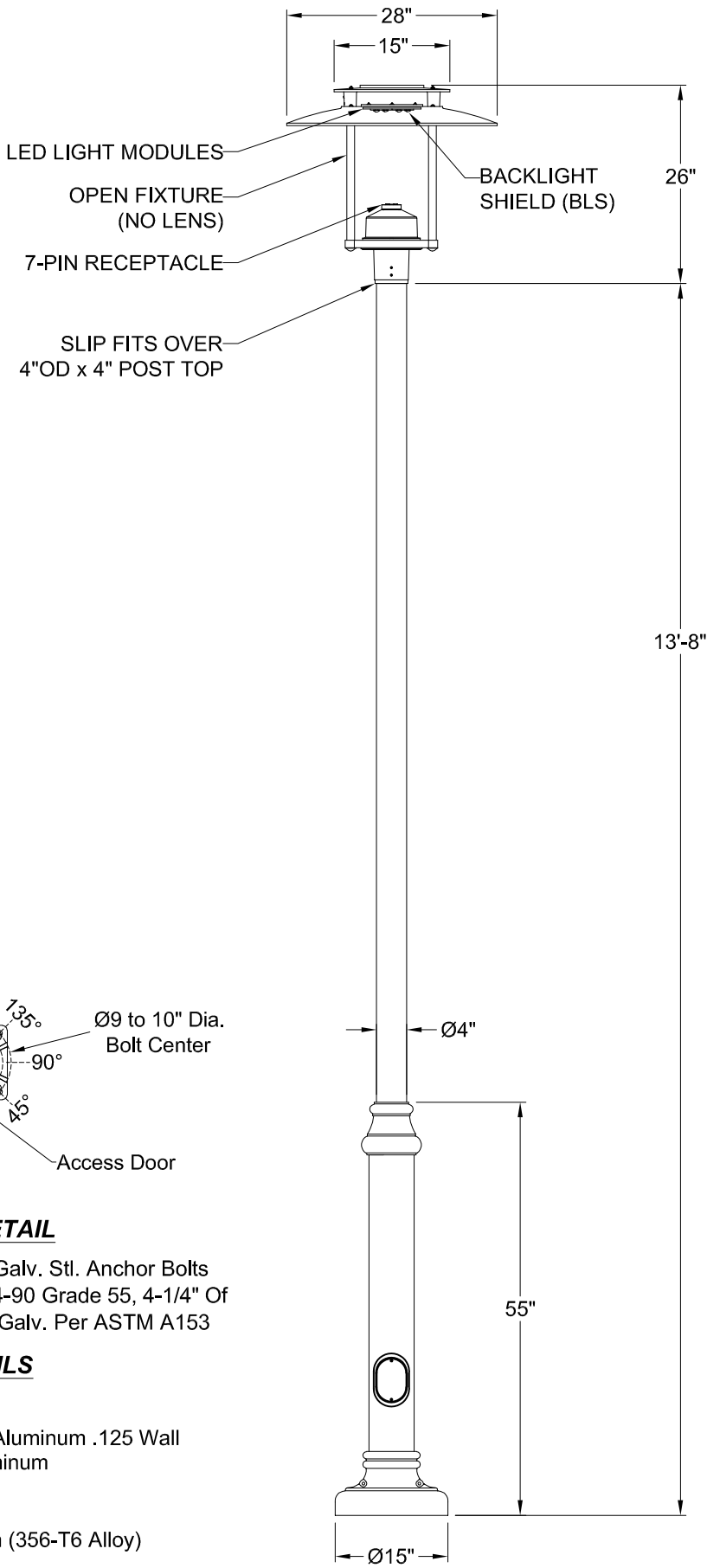

ANCHOR DETAIL

(4) 3/4"-10NC Galv. Stl. Anchor Bolts
AASHTO M314-90 Grade 55, 4-1/4" Of
Threaded End Galv. Per ASTM A153

POLE DETAILS

Shaft
Ø4" Extruded Aluminum .125 Wall
#6063-T6 Aluminum

Base
Cast Aluminum (356-T6 Alloy)

Approved By _____ Date _____

NOTICE: THIS DRAWING IS FOR REFERENCE ONLY. CHECK FOR LATEST REVISION PRIOR TO ORDERING. THIS DRAWING SHOULD ACCOMPANY YOUR ORDER. THANK YOU

www.amerlux.com
178 Bauer Drive
Oakland N.J. 07436
(973) 882-5010
quotes@amerlux.com

DATE
4/20/2023

QUOTE#/SO#
2381237

JOB NAME:
ARLINGTON HIGH SCHOOL - SITE AND BIKE PATH

LIGHT DISTRIBUTION
 TYPE II DISTRIBUTION

FINISH

- BLK Satin black
- CLB Classic bronze
- GBZ Gloss textured bronze
- GRN Green
- GTB Gloss textured black
- TBK Textured black
- CSTM Custom, consult factory

POLYESTER POWDER COAT

VOLTAGE

- 120
- 208
- 240
- 277
- 480
- 120-277V

LIGHT SOURCE

- LED
- HPS
- MH

FILE NAME
ED-91232_ARLINGTON HIGH SCHOOL_2381237.dwg

DRAWN BY
CR

REVISION
1

WINDLOAD DETAILS

Pole: Max allowable EPA- 11.9 Sq Ft at 100MPH Wind Speed.
Luminaire: 0.86 Sq.Ft
Banner EPA (varies by type)
KBW Airow-Single 4.1 / Twin 8.2



GENERAL:
EXTERIOR HARDWARE WILL BE STAINLESS STEEL.
ELECTRICAL COMPONENTS WILL BE ETL LISTED "SUITABLE FOR WET LOCATIONS."

TYPE
PT02-3 2153

PART STRING
EDR-8599-DC216FC-30-T3-530M-BLK-MOD-7P
AP7204-14-BLK-LT

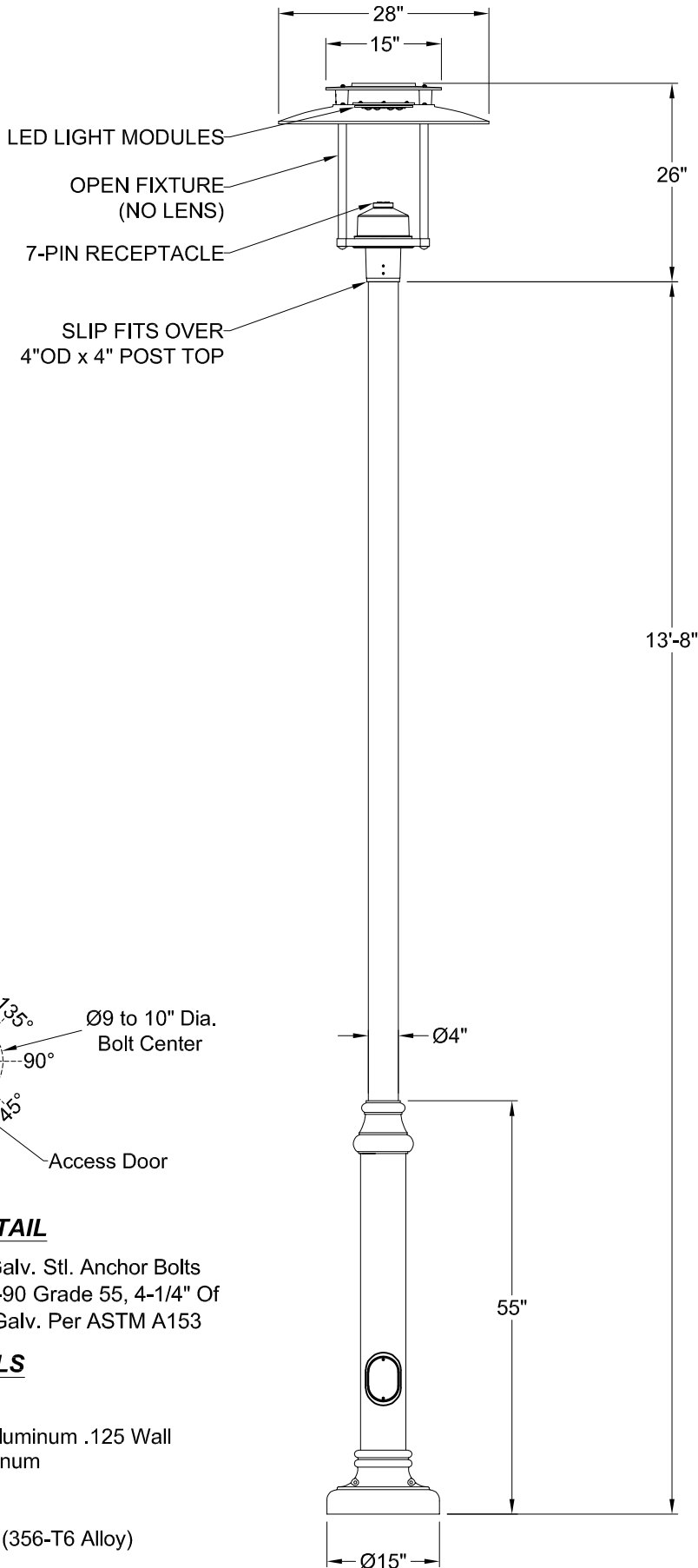

DATE 4/20/2023
QUOTE#/SO# 2381237
JOB NAME: ARLINGTON HIGH SCHOOL - SITE AND BIKE PATH

LIGHT DISTRIBUTION
 TYPE III DISTRIBUTION

FINISH
 BLK Satin black
 CLB Classic bronze
 GBZ Gloss textured bronze
 GRN Green
 GTB Gloss textured black
 TBK Textured black
 CSTM Custom, consult factory
POLYESTER POWDER COAT

VOLTAGE
 120 277 120-277V
 208 480
 240

LIGHT SOURCE
 LED
 HPS
 MH

FILE NAME
ED-91233_ARLINGTON HIGH SCHOOL_2381237.dwg

DRAWN BY CR

REVISION 1

WINDLOAD DETAILS
Pole: Max allowable EPA- 11.9 Sq Ft at 100MPH Wind Speed.
Luminaire: 0.86 Sq.Ft
Banner EPA (varies by type)
KBW Airow-Single 4.1 / Twin 8.2

ANCHOR DETAIL

(4) 3/4"-10NC Galv. Stl. Anchor Bolts
AASHTO M314-90 Grade 55, 4-1/4" Of Threaded End Galv. Per ASTM A153

POLE DETAILS

Shaft
Ø4" Extruded Aluminum .125 Wall
#6063-T6 Aluminum
Base
Cast Aluminum (356-T6 Alloy)

Approved By _____ Date _____

NOTICE: THIS DRAWING IS FOR REFERENCE ONLY. CHECK FOR LATEST REVISION PRIOR TO ORDERING. THIS DRAWING SHOULD ACCOMPANY YOUR ORDER. THANK YOU



GENERAL:
EXTERIOR HARDWARE WILL BE STAINLESS STEEL.
ELECTRICAL COMPONENTS WILL BE ETL LISTED "SUITABLE FOR WET LOCATIONS."

Weber, Chris

From: Weber, Chris
Sent: Tuesday, August 22, 2023 1:43 PM
To: aduffy@hmfh.com; Jim Burrows; Nguyen, Sy
Cc: LaMarre, John
Subject: FW: Arlington High School - CR606.1 - PR-22 Bike Path Options
Attachments: Proposal 203.pdf; Proposal 204.pdf

All – FYI below.

Due to expiration of vendor pricing, WJGEI proposals for both PR-022 Bike Bath Lighting options are considered void.

If a final scope is determined/issued WJGEI can pursue updated vendor pricing at that time.

Consigli will keep CR606.1 status as “Submitted” on the CR Log for ROM Value purposes.

Thanks



Chris Weber
Project Manager
m: 774.573.4072
 consigli.com

From: Wayne Pease <WPEASE@WJGEI.com>
Sent: Tuesday, August 22, 2023 12:35 PM
To: Weber, Chris <cweber@consigli.com>
Cc: LaMarre, John <JLaMarre@consigli.com>
Subject: Arlington High School - PR-22 Bike Path Options

Caution: External Email.

Chris,

This is to inform you that our proposals for the bike path options (PR-22) have expired and have been voided. If the owner wishes to consider this change at a later date, please let me know which option and I will secure updated pricing for review.

Thanks

Wayne

H M
F H

PROPOSAL REQUEST

PR: 022

date: 3.30.2023

subject: Addition of lighting along bikepath connector ramp

to: Consigli Construction Co. **from:** HMFH Architects

project id: 408417

project: Arlington High School
869 Massachusetts Avenue, Arlington MA

distribution: Skanska Consigli
 HMFH Architects Other: BALA

reference: Drawing E 3.0.2

attachments: Option 1 & Option 2 photometric layouts from Reflex Lighting

OFFICE: (617) 492 2200
FAX: (617) 876 9775

130 Bishop Allen Drive
Cambridge, MA 02139

hmfh.com

Please submit an itemized proposal for changes in Contract Sum and Contract Time for proposed modifications to the Contract Documents described herein. This is not a Change Order, a Construction Change Directive or a direction to proceed with the work described in the proposed modifications.

Please provide pricing for the attached bike path connector ramp lighting options 1 and 2

Option 1: Qty. (5) PT01-3 + Qty. (2) PT01-2 fixtures and associated bases
(28' tall fixtures)

Option 2: Qty. (8) PT02-2 + Qty. (2) PT02-3 fixtures and associated bases
(14' tall fixtures)

See attached photometric plans for reference on layout of above noted quantities

Pricing for both options to be reviewed with the owner for final decision. Upon said decision by owner, further details and civil / landscape drawings on exact locations of light poles to be provided.

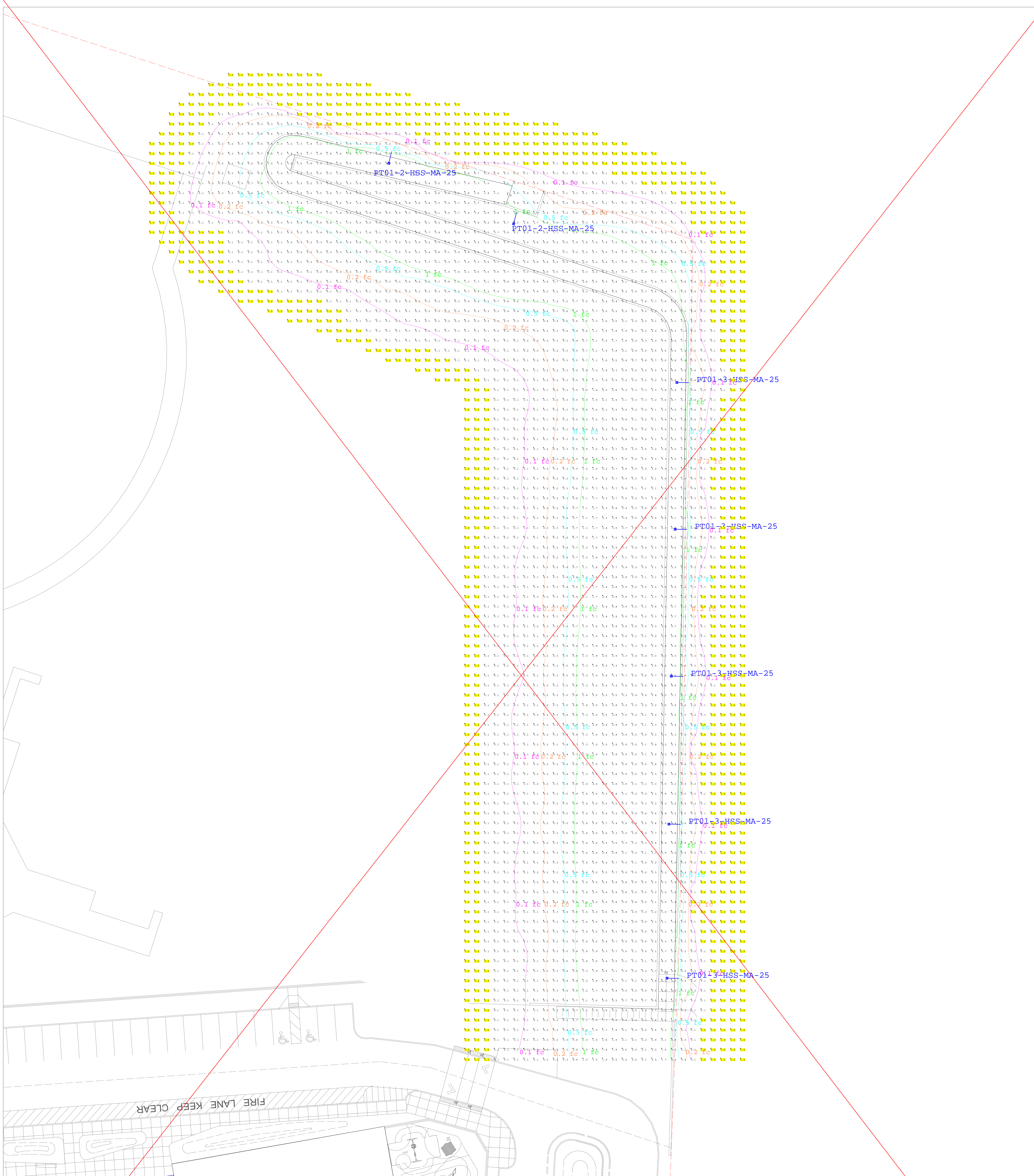

Luminaire Schedule			Luminaire Watts	Luminaire Lumens	LLF
Qty	Symbol	Description			
3		PT01-2-HSS-MA-25 MCGRAW: GLEON-AF-04-LED-E1-SL2-MA-BK-8030-800-HSS-ZW-SWPD5BK (6' MAST ARM, 25' POLE)	171	13111	0.900
5		PT01-3-HSS-MA-25 MCGRAW: GLEON-AF-04-LED-E1-SL3-MA-BK-8030-800-HSS-ZW-SWPD5BK (6' MAST ARM, 25' POLE)	171	13524	0.900

Calculation Summary						
Label	Units	Avg	Max	Min	Avg/Min	Max/Min
SITE (ALL POINTS)	Fc	0.94	6.0	0.0	N.A.	N.A.
BIKE PATH	Fc	2.64	6.0	1.0	2.64	6.00



Luminaire Schedule								
Qty	Symbol	Label	Description	Luminaire Watts	Luminaire Lumens	LLF		
8	●	PT02-2-HS	AMERLUX: DC216FC-30-T2-530M-BLK-BLS-MOD(NEMA 7-PIN) 14' POLE	44.13	3537	0.900		
2	●	PT02-3-HS	AMERLUX: DC216FC-30-T3-530M-BLK-BLS-MOD(NEMA 7-PIN) 14' POLE	44.13	3430	0.900		
1	—□	PT01-2-HSS-MA-25	MCGRAW: GLEON-AF-04-LED-E1-SL2-MA-BK-8030-800-HSS-ZW-SWP5BK (6' MAST ARM, 25' POLE)	171	13111	0.900		

Calculation Summary						
Label	Units	Avg	Max	Min	Avg/Min	Max/Min
SITE (ALL POINTS)	Fc	0.37	5.5	0.0	N.A.	N.A.
BIKE PATH	Fc	2.56	5.5	1.0	2.56	5.50



AHS- ARLINGTON HIGH SCHOOL
SITE LIGHTING- BIKE PATH- OPTION 2

Drawn By: A.M.
 Date: 3/20/2023
 Specifier: RIPMAN
 Salesperson:
 Scale: Not to Scale

www.reflexlighting.com
 DISCLAIMER: CALCULATIONS SHOULD BE USED AS A GUIDE ONLY. LIGHT LEVELS ARE SUBJECT TO CONDITIONS IN THE FIELD.
 specifications@reflexlighting.com

Weber, Chris

From: Bradd Biagini <bbiagini@JDerenzo.com>
Sent: Thursday, June 1, 2023 9:07 AM
To: Weber, Chris
Cc: Saunders, Mason
Subject: RE: 2153 - CR606 - PR-022 - Bike Path Lighting Option 2 Comments

Chris I agree with the info in the below screenshot. I understand it now.

The added 210' of conduit E&B would be \$8,795.00 if they go with that option. The bases are covered either way.

SO: 21 (19 PH1 bases plus the use of the granite sign value as 2 bases) of 35 pole bases from EBP2 scope was utilized. THUS: 14 pole bases scope remains.

This Option 1 requires 7 pole bases. THUS: there remains a balance of 7 bases owned under EBP2

Option 2 requires 10 pole bases. THUS: there remains a balance of 4 bases owned under EBP2

CR489 asked for \$3,159.45 for sanitize footings at granite sign lights. Was voided for offset against some of the 35 pole bases. = value of 2 pole bases



Bradd Biagini
 Project Manager
 J. Derenzo Company
 338 Howard St., Brockton, MA 02302
 O 508.897.8035 | C 508.962.3418
www.jderenzo.com



From: Weber, Chris <cweber@consigli.com>
Sent: Wednesday, May 31, 2023 10:44 AM
To: Bradd Biagini <bbiagini@JDerenzo.com>
Cc: Saunders, Mason <msaunders@consigli.com>
Subject: 2153 - CR606 - PR-022 - Bike Path Lighting Option 2 Comments

J. DERENZO COMPANY



April 4, 2023

Consigli Construction Company
72 Sumner Street
Milford, MA 01757

Attn: **John LaMarre, Senior Project Manager**
Project: **Arlington High School Phase 2-4**
Re: **PCO 18- PR #22 Added Site Lighting and Light Bases**

Dear John,

J. Derenzo is pleased to provide this proposal for the added cost associated with excavating and backfilling for the added site lighting conduit and bases per PR #22. Bases provided by electrician.

~~The total added cost is \$25,187.00~~ **\$8,075**

~~Deduct \$4,086.00 if 3 bases are removed from scope.~~

Please do not hesitate to contact me if you have any questions.

Respectfully,
J. DERENZO CO.

Bradd Biagini

Bradd Biagini
Project Manager

AS SHOWN

Item:	1	Unit of Measure:	LF
Description:	E&B ADDED SITE LIGHTING CONDUIT	Bid Quantity:	300.00
Cost Code:		Take-off Quantity:	300.000
Production:	DAYS	Total Man-Hours:	32.00
Hours per Day:	8	Man-Hours per Unit:	0.1067
Alternate:		Units / MH:	9.3750

Item Production

ITEM#	DESCRIPTION	U/M	QTY	Time Units	Time Req'd
1	E&B ADDED SITE LIGHTING CONDUIT	LF	300.00	150.00 (D)	2.00

Cost Detail for Item 1

R Code	Description	QTY	U/M	Factor	Rate	Cost
L FOREMAN	Foreman	1.00		2.00	1,185.12	2,370.24
L LABORER	Laborer	1.00		2.00	765.76	1,531.52
E EXV-308	CAT 308 Excavator w/Operator	1.00		2.00	2,373.44	4,746.88
E LDR-950	CAT 950 Loader w/Operator	1.00		1.00	2,432.56	2,432.56
M SAND	Bedding Sand	22.00	TONS	1.10	20.00	484.00

Item Unit Cost: 38.55
Item Total Cost: ~~11,565.20~~ ✓
\$8,075

	Labor	Equipment	Rental Eq	Material	Subcontract	Other
Total:	3,901.76	7,179.44	0.00	484.00	0.00	0.00
Unit:	13.01	23.93	0.00	1.61	0.00	0.00

Bid Data for Item: 1

	Quantity	Bid Unit	Bid Amount	Total Cost	Prof & Ovhd	Windfall
Bid Qty:	300.00	38.55	11,565.20	11,565.20	0.00	
Take-off Qty:	300.00	38.55	11,565.20	11,565.20	0.00	0.00

\$8,075

AS SHOWN

Item:	2	Unit of Measure:	EA
Description:	E&B ADDED LIGHT POLE BASES	Bid Quantity:	10.00
Cost Code:		Take-off Quantity:	10.000
Production:	DAYS	Total Man-Hours:	42.00
Hours per Day:	8	Man-Hours per Unit:	4.2000
Alternate:		Units / MH:	0.2381

Item Production

ITEM#	DESCRIPTION	U/M	QTY	Time Units	Time Req'd
2	E&B ADDED LIGHT POLE BASES	EA	10.00	4.00 (D)	2.50

Cost Detail for Item 2

R Code	Description	QTY	U/M	Factor	Rate	Cost
L FOREMAN	Foreman	1.00		2.50	1,185.12	2,962.80
L LABORER	Laborer	1.00		2.50	765.76	1,914.40
L SURVEYOR	Surveyor	1.00		0.25	1,515.44	378.86
E EXV-308	CAT 308 Excavator w/Operator	1.00		2.50	2,373.44	5,933.60
E LDR-950	CAT 950 Loader w/Operator	1.00		1.00	2,432.56	2,432.56
Item Unit Cost:		1,362.22			Item Total Cost:	13,622.22 ✓

	Labor	Equipment	Rental Eq	Material	Subcontract	Other
Total:	5,256.06	8,366.16	0.00	0.00	0.00	0.00
Unit:	525.61	836.62	0.00	0.00	0.00	0.00

Bid Data for Item: 2

	Quantity	Bid Unit	Bid Amount	Total Cost	Prof & Ovhd	Windfall
Bid Qty:	10.00	1,362.22	13,622.22	13,622.22	0.00	
Take-off Qty:	10.00	1,362.22	13,622.22	13,622.22	0.00	0.00



Change Request

To: Jim Burrows
 Skanska USA Building Inc.
 253 Summer Street
 Boston, MA 02210
 Ph: 617-574-1524 Fax: 617-574-1399

Number: CR747
Date: 2/6/24
Job: 2153 Arlington High School
Phone:

Description: CCD-055 - Add (2) Exit Signs in Auditorium (Ph.1)_T&M_Sub.021524

Source: CCD # 055

We offer the following specifications and pricing to make the changes as described below:



CR748 includes Wayne Griffin + Riggs costs associated with CCD-055 Add Two (2) Lighted Exit Signs in Auditorium (PH 1) issued by HMFH on 1/29/24. Pricing included within includes the F&I of (2) lighted exit signs in the PH 1 Auditorioium that were requid by the AHJ. These signs were not orginally shown in the contract documents. CCC has proceeded in order to meet AHJ requirements as required. Please see the attached pricing and assoicated backup for additional information.

Qualifications + Assumptions:

- Overtime included
- No patching/painting included, if required will be submitted under seperate cover

Description	Labor	Material	Equipment	Subcontract	Other	Price
WJGEI - Proposal #308 dated 2/13/24				\$4,895.54		\$4,895.54
Riggs General Requirements				\$500.00		\$500.00
					Subtotal:	\$5,395.54
			Bond (.75%)	\$5,395.54		\$40.47
			General Liability (1.2%)	\$5,395.54		\$64.75
			Subguard (1.4%)	\$500.00		\$7.00
			OH&P (5% subs, 10% self perform)	\$5,507.76		\$275.39
					Total:	\$5,783.15

- SCHEDULE IMPACT
- We have proceeded with this change to achieve schedule.
- As directed, we will not proceed with this change until formal direction from OWNER is received.

ARCHITECT  _____ (Signature) Arthur Duffy _____ By 02/26/2024 _____ Date	Consigli Construction Co., Inc. CONTRACTOR 72 Sumner Street Milford, MA 01757  _____ (Signature) John LaMarre _____ By 2/21/24 _____ Date	OWNER _____ (Signature) _____ By _____ Date
--	--	---



WAYNE J.
GRIFFIN ELECTRIC
INC.

116 Hopping Brook Road, Holliston, MA 01746
(508) 429-8830 FAX (508) 429-9251
MA LIC. A8999, 4536A1

INVOICE

MR. CHRIS WEBER
Sold To: CONSIGLI CONSTRUCTION COMPANY, INC.
72 SUMNER STREET
MILFORD, MA 01757

Work Done At: ARLINGTON HIGH SCHOOL
869 MASS AVENUE
ARLINGTON, MA 02476

JOB NO. 02698-00-20	PO Nbr	Terms Net 30 Days	PLEASE REMIT BY INVOICE NUMBER	P0308	Invoice Date 2/13/2024
------------------------	--------	----------------------	-----------------------------------	-------	---------------------------

DESCRIPTION OF WORK:

RE: Job#2698- Arlington High School
Proposal#P0308

As directed in the field, to provide and install two additional ceiling mounted exit signs at the Auditorium. Please see attached sketch SKE-96.

INVOICE TOTAL

4,895.54



Terms: Net 30 Days with 1.5% Interest on all Unpaid Balance over 30 days

If you have any questions regarding the above, please do not hesitate to contact me at (508) 306-5313 or wpease@wjgei.com.

Very truly yours,

WAYNE J. GRIFFIN ELECTRIC, INC.



Wayne A. Pease
Senior Project Manager

WP/law

ACKNOWLEDGMENT: The contract modifications stated for the above field change are acceptable for the work already performed. The value of the work completed to the date of the next requisition may be billed on that requisition.

Date: _____ Authorized Signature: _____

cc: John LaMarre, Senior Project Manager, Consigli Construction Company, Inc., J
JLaMarre@consigli.com
Jeremiah Kimball, Project Foreman, Wayne J. Griffin Electric, Inc.



CCN#: P-0308, CCD-055 Auditorium Exit Light Sign
 Date: 2/12/2024
 Project Name: Arlington High School
 Project Number: 02698-00-20
 Page Number: 1

116 Hopping Brook Road, Holliston, MA 01746
 (508) 429-8830 FAX (508) 429-9251

Work Description

As directed in the field, to provide and install two additional ceiling mounted exit signs at the Auditorium . Please see attached sketch SKE-96.

Itemized Breakdown

Description	Qty	Net Price	UM	Materials (\$)	Labor	Total Hours
Work Authorization 2-3-24 to 2-5-24	20.00	0.0000	E	0.000	1.000	20.000
XRC1 Exit Signs	2.00	235.0000	E	470.000	0.000	0.000
Freight	1.00	65.0000	E	65.000	0.000	0.000
12/2 MC Cable	200.00	1.0300	E	206.000	0.000	0.000
MC Supports	25.00	1.7500	E	43.750	0.000	0.000
MC Connectors	6.00	1.0400	E	6.240	0.000	0.000
4" Square Boxes	4.00	6.1500	E	24.600	0.000	0.000
4" Square Blank Covers	2.00	1.5000	E	3.000	0.000	0.000
Box Supports	4.00	1.9800	E	7.920	0.000	0.000
Wire Connectors	12.00	0.1900	E	2.280	0.000	0.000
Ground Screw Pigtails	4.00	0.9300	E	3.720	0.000	0.000
Lock-out Tag-out	1.00	29.0000	E	29.000	0.000	0.000
Caulking	1.00	19.6500	E	19.650	0.000	0.000
Plastic Tape	1.00	3.8300	E	3.830	0.000	0.000
Phase Totals				884.99		20.00
			Totals	884.99		20.00
			Tax	0.00		
			Materials with Tax	884.99		

Summary

Itemized Breakdown Total		884.99	
Electrical Journeyman Overtime	(18.0000 hrs @ \$140.79 / hr)	2,534.22	
Electrical Journeyman	(2.0000 hrs @ \$93.86 / hr)	187.72	
		2,721.94	✓
Labor Burden	(\$2,721.94 @ 30.00%)	816.58	✓
		816.58	
Overhead & Profit	(\$4,423.51 @ 10.00%)	442.35	✓
		442.35	
Bond	(\$4,865.86 @ 0.61%)	29.68	✓
		29.68	
Total		1,288.61	
		\$4,895.54	✓

WAYNE J. GRIFFIN ELECTRIC INC. 116 HOPPING BROOK ROAD HOLLISTON, MA 01746 TEL: 508-429-8830 FAX 508-429-7825	WORK AUTHORIZATION		CCC - CR747		
			Check one:		
			Page (1) of (1)	Time&Material	<input checked="" type="checkbox"/>
			Reference Number:	Service Division	<input type="checkbox"/>
Consigli		CCD-055: AHS Auditorium- EXIT light signs		Other - Specify <input type="checkbox"/>	
72 Sumner Street				Emergency Call	
Milford	MA, 01757			Customer PO	

PREWORK AUTHORIZATION		Date: 1-29-24	
AUTHORIZED SIGNATURE: Chris Weber		Via email 1-29-24	

YOU ARE HEREBY AUTHORIZED TO PERFORM THE ABOVE ADDITIONAL WORK UNDER THE SAME CONDITIONS AS SPECIFIED IN THE ORIGINAL CONTRACT PROPOSAL UNLESS OTHERWISE STIPULATED.

MATERIAL AND LABOR BREAKDOWN			
2	Type XRC1 Exit Signs	1	Lock-out Tag-out
200'	12/2 MC Cable	1	Caulking
25	MC Supports	1	Plastic Tape
6	MC Connectors	1	Freight
4	4" Sq Boxes		
2	4" Sq Blank Covers		
4	Box Supports		
12	Wire Connectors		
4	Ground Screw Pigtails		

TIME AND LABOR RECORD									
Worker:	Date:	Hours:	Worker:	Date:	Hours:	Worker:	Date:	Hours:	Total Man Hours
Jeremiah Kimball	2/3/2024	5							20
Gregory J. Corley	2/3/2024	6.5							
Jasmin Smajilovic	2/3/2024	6.5							
Jeremiah Kimball	2/5/2024	2							

Electronic copy on file	Post work Authorized Signature	DATE:
	The Labor and materials listed above are accurate and the work was completed satisfactorily	

Construction Change Directive (CCD)

NO:
055

Date of Issuance: January 29, 2024

Project:	Arlington High School	Contract For:	New Construction
Address:	869 Massachusetts Avenue, Arlington, MA 02476	Contract Date:	June 26, 2019
Owner:	Town of Arlington		
Address:	730 Massachusetts Avenue, Arlington, MA 02476	Project ID:	408417
From:	HMFH Architects, Inc	To:	Consigli Construction Co., Inc
Address:	130 Bishop Allen Drive, Cambridge, MA 02139	Address:	Milford, MA

You are hereby directed to make the following change(s) in this Contract:

Provide two ceiling mounted exit signs at the Auditorium. Refer to attached sketch SKE-96.
(per AHJ requirement)

PROPOSED ADJUSTMENTS:

1. The proposed basis of adjustment to the Contract Sum or Guaranteed Maximum Price is:

- Lump Sum increase of: NTE \$ xx,xx (Final amount TBD)
- Unit Price of \$ per
- On a Time & Materials Basis
- As follows:

2. The Contract Time shall **BE UNCHANGED**. Such an adjustment, if any, shall be 0 days from the date of Substantial Completion.

When signed by the Owner and Architect and received by the Contractor, this document becomes effective IMMEDIATELY as a Construction Change Directive (CCD), and the Contractor shall proceed with the change(s) described above.

Contractor signature indicates agreement with the proposed adjustments in Contract Sum and Contract Time set forth in this CCD.

HMFH Architects ARCHITECT 130 Bishop Allen Drive Cambridge, MA ADDRESS 	Town of Arlington Owner 730 Massachusetts Avenue Arlington, MA ADDRESS	Consigli Construction Co., Inc. Contractor 72 Summer Street Milford, MA ADDRESS
BY (Signature) Arthur Duffy	BY (Signature)	BY (Signature)
(Typed Name) 01/29/2024	(Typed Name)	(Typed Name)
DATE	DATE	DATE

Attachments:	Sketch SKE-96	
distribution:	<input checked="" type="checkbox"/> Owner - James Feeney	<input checked="" type="checkbox"/> Architect - Arthur Duffy, Lori Cowles
	<input checked="" type="checkbox"/> OPM - J Burrows, Sy Nguyen, H. Raymond	<input checked="" type="checkbox"/> Contractor - J. LaMarre, C. Weber,
	<input checked="" type="checkbox"/> Consultant - Bala	<input checked="" type="checkbox"/> Field - C. McWilliams, T.DeRosa



Add lighted EXIT sign (ceiling mounted)



Add lighted EXIT sign (ceiling mounted)



BALA
ENGINEERS

Ref. DWG. E3.2e

CCD-055

HMPH ARCHITECTS

Arlington High School

LIGHTING PLAN PART e: TWO ADDITIONAL EXIT SIGNS

DRAWING NUMBER

SKE
96

180 Bishop Allen Drive
Cambridge, MA 02138
617 482 2300
@HMPHarch hmfh.com

HM
FH

SCALE: 1/8" = 1'-0" DATE: 01/20/2024 DRAWN: AD CHECKED:

JOB NUMBER 0212042



Change Order - Quotation

TO:
W GRIFFIN ELEC HOLLISTON
116 HOPPING BROOK RD
HOLLISTON, MA 01746-1497

Project: ARLINGTON HIGH SCHOOL - 119209
Date: 02/08/24
PO #: 232999

Freight in Exempt : No

Material Change: **470.00**

Change Type	Quantity Description	Unit or Lot#	Unit Price	Ext Price	Change Amt
✓ XRC1	2 UEL-AC-G-1C2M-MTEBR <u>Prev Qty</u> <u>Change Qty</u> <u>New Qty</u> 0 2 2 ** New Item **	ISOLITE	470.000	470.00	470.00
✓ XRC1	2 EUNG1M <u>Prev Qty</u> <u>Change Qty</u> <u>New Qty</u> 0 2 2 ** New Item **	ISOLITE			

Total	470.00
--------------	---------------

From:
NORTHEAST ELECTRICAL
SALES 978-374-4111
560 OAK STREET
BROCKTON, MA 02301
Printed By: ALISON GERMAIN

Authorizing Name: ALISON GERMAIN
File Number: 912
CCD-055

These items are not ordered! To complete this order, sign below and provide a PO # for the order.

Signature: _____



Construction Change Directive (CCD)		CCC - CR747 NO: 055
Date of Issuance:	January 29, 2024	

Project:	Arlington High School	Contract For:	New Construction
Address:	869 Massachusetts Avenue, Arlington, MA 02476	Contract Date:	June 26, 2019
Owner:	Town of Arlington		
Address:	730 Massachusetts Avenue, Arlington, MA 02476	Project ID:	408417
From:	HMFH Architects, Inc	To:	Consigli Construction Co., Inc
Address:	130 Bishop Allen Drive, Cambridge, MA 02139	Address:	Milford, MA

You are hereby directed to make the following change(s) in this Contract:

Provide two ceiling mounted exit signs at the Auditorium. Refer to attached sketch SKE-96. (per AHJ requirement)

PROPOSED ADJUSTMENTS:

- The proposed basis of adjustment to the Contract Sum or Guaranteed Maximum Price is:
 - Lump Sum increase of: NTE \$ xx,xx (Final amount TBD)
 - Unit Price of \$ per
 - On a Time & Materials Basis
 - As follows:
- The Contract Time shall **BE UNCHANGED**. Such an adjustment, if any, shall be **0** days from the date of Substantial Completion.

When signed by the Owner and Architect and received by the Contractor, this document becomes effective IMMEDIATELY as a Construction Change Directive (CCD), and the Contractor shall proceed with the change(s) described above.		Contractor signature indicates agreement with the proposed adjustments in Contract Sum and Contract Time set forth in this CCD.
HMFH Architects ARCHITECT 130 Bishop Allen Drive Cambridge, MA ADDRESS BY (Signature) Arthur Duffy (Typed Name) 01/29/2024 DATE	Town of Arlington Owner 730 Massachusetts Avenue Arlington, MA ADDRESS BY (Signature) (Typed Name) DATE	Consigli Construction Co., Inc. Contractor 72 Summer Street Milford, MA ADDRESS BY (Signature) (Typed Name) DATE

Attachments:	Sketch SKE-96	
distribution:	<input checked="" type="checkbox"/> Owner – James Feeney	<input checked="" type="checkbox"/> Architect – Arthur Duffy, Lori Cowles
	<input checked="" type="checkbox"/> OPM – J Burrows, Sy Nguyen, H. Raymond	<input checked="" type="checkbox"/> Contractor – J. LaMarre, C. Weber,
	<input checked="" type="checkbox"/> Consultant – Bala	<input checked="" type="checkbox"/> Field – C. McWilliams, T.DeRosa



Add lighted EXIT sign (ceiling mounted)



Add lighted EXIT sign (ceiling mounted)

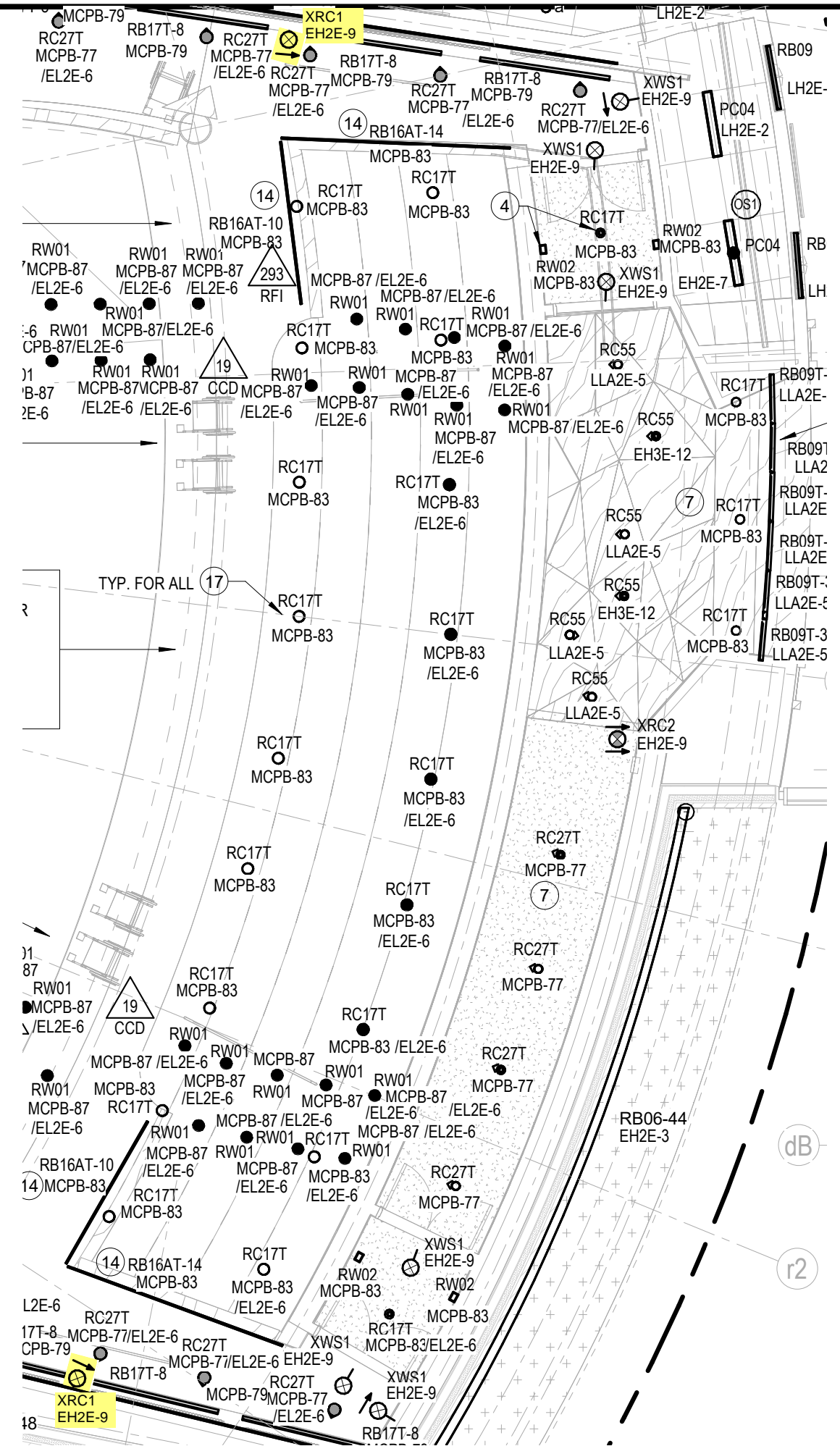

CCD-055

CCC - CR747
 DRAWING NUMBER
SKE
96
 JOB NUMBER
 6017442

Ref. DWG. E3.2e

Arlington High School
 LIGHTING PLAN PART e: TWO ADDITIONAL EXIT SIGNS

BALA
 ENGINEERS

PHILADELPHIA | NEW YORK | BOSTON | BALTIMORE
 ARCHITECTS | INTERIORS | ELECTRICAL | MECHANICAL | PLUMBING
 ENVIRONMENTAL | TECHNOLOGY | COMMUNITARIANS

HMFH ARCHITECTS
 130 Bishop Allen Drive
 Cambridge, MA 02139
 617 492 2200
 @HMFHarch hmfh.com

SCALE: 1/8" = 1'-0"
 DATE: 01/29/24
 DRAWN: AD
 CHECKED:

FINANCIAL

Change Order & Contract Status

Original Contract Amount:	\$	234,562,347.00
Previously Approved Change Orders:	\$	3,696,300.00
Current Contract Amount:	\$	238,258,647.00
Verbally Approved Changes:	\$	284,940.00
Submitted Changes:	\$	727,360.00
Pending Changes:	\$	119,625.00
Total Potential Changes:	\$	1,131,925.00
Projected Contract Amount:	\$	239,390,572.00

Billing Status

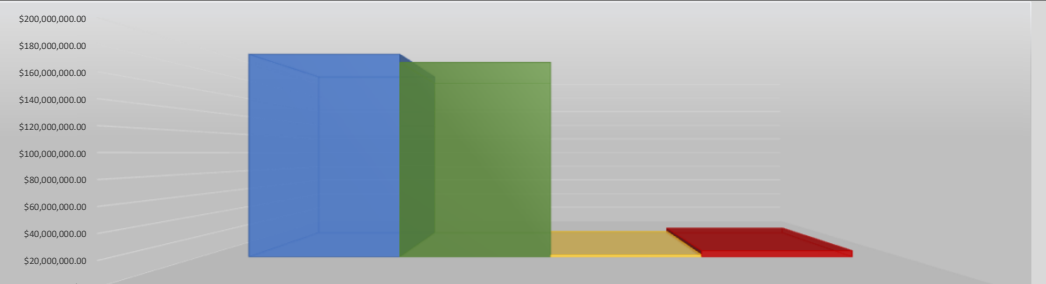

Billed to Date	\$	194,267,836	Retainage Held	\$	1,859,179
Paid to Date	\$	186,374,019	Amount Outstanding	\$	6,034,638

Allowance Status

Original Allowance Budget	\$	4,321,945.00
Expended to Date	\$	3,519,734.00
Remaining Allowances	\$	802,211.00

Holds Status

Original Holds Budget	\$	583,706.0
Expended to Date	\$	264,212.00
Remaining Holds	\$	319,494.00

Contingency Status

Original Cont. Amount:	\$	6,967,419
Expended to Date	\$	6,345,782
Remaining Contingency:	\$	621,637

Procurement Overview

Percent Complete:	100.0%
Buyout Savings / (Bust)	22,853
Buyout Savings / (Bust) %	0%

EXECUTIVE OVERVIEW

- Phase 3 PIFs installation was completed for BLDA A in March. Bldg. A concrete foundations (Pile Caps, Grade Beams) are well on the way and will continue into early April. Backfilling of these structural elements to follow placements. Steel erection is set to begin in mid-April.
- Prep work for minuteman bike path and toilet facility have started in the month of March. Test pits for bike path to begin in first week of April.
- PH 2 punch list completion continued in March for Bldg. B/C2. Currently, overall punch list totals: (83) open items, (20) items ready to close. Subcontractors will continue to finalize punchlist over the schools Good Friday holiday and April Vacation.
- Decisions required. A) District to provide direction for Phase 3 Super Graphics & Signage for formal issuance of design files in order to produce submittals, procure/release materials. B) Design for west parking lot PV.
- As of the 3/28/24 Schedule Update, Phase 3 TCO is currently on schedule for February 2025 turnover. Phase 4 and overall project completion are currently on schedule, and new fields are on track for use at the return of the Fall 2025 school year.

SCHEDULE

Project Milestones

Milestone	Target	Actual	Variance
Completion of Phase 1 (Temporary Certificate of Occupanc	2/11/2022	2/11/2022	0
Completion of Phase 1 - Auditorium (TCO)	4/4/2022	4/14/2022	0
Completion of Phase 2 - B & C2	10/30/2023	10/30/2023	0
Complete Link and Connector Demo	12/1/2023	12/1/2023	0
Completion of Phase 2 - PreK	12/15/2023	12/15/2023	0
All Demo & Abatement Complete (Phase 3)	2/6/2024	2/6/2024	0
Underslab MEP Complete - Building A	6/11/2024		0
Deck & Detail Complete (Building A)	6/4/2024		0
Completion of Phase 3	12/16/2024		0
Completion of Phase 4	10/20/2025		

Roadblocks

Item	Ball In Court	Due Date
#2024 - RFI-308.2 - Ph 2 + 3 Signage Decision & Design	HMFH	10/9/2022
#2037 - Ph. 2 + 3 Dedication Plaques Design	HMFH	10/9/2022
#2038 - RFI-308.2 - Room Naming Design	HMFH	10/16/2022
#3416 - PV Design for West Parking Lot	HMFH	11/25/2023

QUALITY

Construction Submittal Status

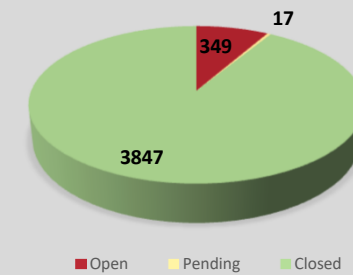

RFI Status

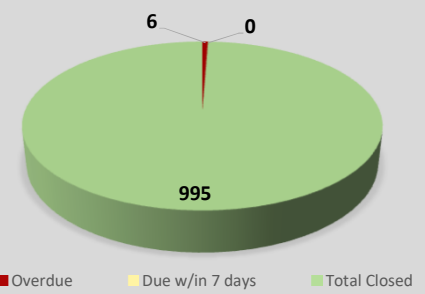

Observation Review

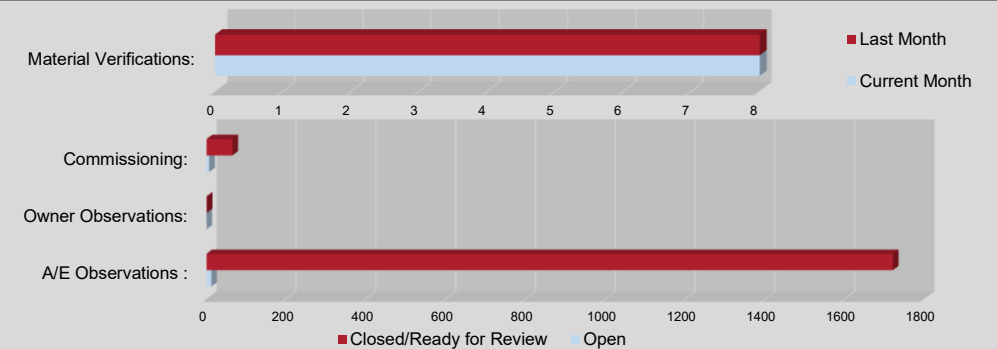

Safety Update

Current Project Safety Score:	99.4%
Total Man Hours to Date:	749,680
OSHA Recordables to Date/Month:	2/0

Workforce Utilization Reporting

Minority Participation	24.5%
Women Participation	3.8%

PROGRESS PHOTOS



Arlington HS – March Progress Photos



Overall Site– Drone (PH 3)

Arlington HS – March Progress Photos



Phase 3 Pile Caps + Grade Beams

Arlington HS – March Progress Photos



Soil Amendment Ongoing (PH 3)

Arlington HS – March Progress Photos



Bike Ramp
Tree Clearing

Arlington High School Building Committee

Meeting Date: Tuesday, March 5th, 2024, 6:00 p.m.
Location: Conducted via Remote Participation

Jeff Thielman, School Committee Representative, Chair
Elizabeth Homan, Superintendent, Co-vice chair
Jim Feeney Town Manager, Co-vice chair
Alex Magee, Deputy Town Manager, absent
Kirsi Allison-Ampe, School Committee Representative
Francis Callahan, Community Member Representative
John Cole, Permanent Town Building Committee
Tobey Jackson, Community Member Representative
Matthew Janger, AHS Principal, absent
Ryan Katofsky, Community Member Rep
Brett Lambert, PTBC Representative
Kate Loosian, Community Member Representative
Michael Mason, APS Chief Financial Officer, absent
William McCarthy, AHS Assistant Principal, arrived 6:40
Judson Pierce, Community Member
Paul Raia, Disabilities Commission Rep, absent
Rob Behrent, Facilities Dir, Town of Arlington, absent
Amy Speare, Community Member Representative
Shannon Knuth, Teacher Representative
Kent Werst, Teacher Representative

Jim Burrows, Victoria Clifford, absent, Sy Nguyen, Jessica Mendez, Skanska
Lori Cowles, Arthur Duffy, HMFH Architects, Inc.
John LaMarre, Chris Weber, Consigli
John Amato
Karen Fitzgerald, AHSBC Recording Secretary

Jeff Thielman opened the meeting at 6:02 p.m. and welcomed everyone to the meeting and confirmed that we had one public participate in the meeting, Grant.

Skanska Update

- ◆ Athletic Field Discussion / Scheduling a follow-up meeting

The Arlington High School Building Committee will draft a Memorandum to the Arlington Conservation Commission no later than March 20, 2024 which provided background and rationale for the AHS Building Committee's request for an extension of an Order of Conditions of synthetic turf fields with crumb rubber infill at the new high school. The Order was granted three years ago by the Conservation Commission and due to going beyond a timeline and nothing has changed, the Conservation Commission needs to reaffirm this decision to go with chrome rubber for the project.

The committee members discussed the Conservation Commission's concerns about potential toxicity for fish in Mill Brook found in a study about the impact on Coho salmon and other fish of 6PPD-quinone. The project team and HMFH consultants have reviewed multiple studies and have concluded that the conditions needed to create 6PPD-quinone are not present in the AHS field design. Dr. Homan and the school department have done extensive research about alternative infill options to crumb rubber and concluded that crumb rubber is the most proven, safest and highest performing infill option. Cost implications of other infill options were also discussed. Ultimately, committee members reaffirmed their decision to keep the existing field design. All committee members were in agreement, therefore the following motion was made:

On a **motion** by Frank Callahan, seconded by Kirsi Allison-Ampe, it was approved that after studying alternative organic infills for the fields at our new high school, evaluating the possibility of using project contingency funds, studying the safety and usage patterns of alternative turf infills, reviewing scientific data distinguishing infill in the new fields and substances from tires on roadways near waterways that may harm aquatic life, and taking steps to limit potential inflow to Mill Brook through added safeguards in the design of the turf field's drainage system; the **Arlington High School Building Committee (AHSBC)** reiterates and restates its intention to purchase and install crumb rubber infill for the new high school fields, as approved by the Order of Conditions granted by the Conservation Commission in 2020, and respectfully requests the Commission to extend the Order as permitted by the Arlington Regulations for Wetland Protection.

Roll Call, Liz Homan, Yes, Jim Feeney, Yes, Kirsi Allison-Ampe, Yes, John Cole, Yes, Frank Callahan, Yes, Tobey Jackson, Yes, Ryan Katofsky, Yes, Brett Lambert, Yes, Kate Loosian, Yes, Judson Pierce, Yes, Amy Speare, Yes, and Jeff Thielman, Yes.

◆ Multistack

Jim Burrows noted the issue is with failures of the Multistack ACHP (Air Conditioning Heat Pump) rooftop units to work at full capacity. Our Mechanical Subcontractor was formally put on notice by Consigli in a letter dated 2/20/24. There has been no impacts to the occupants i.e. heating/cooling of spaces but rather the units are not working at an optimal level. The committee will be made aware of issues and will be provided updates as they come in.

Consigli Update

◆ Schedule Update

- Phase 3 demolition was completed in early February. J.Derenzo/Keller mobilized at the end of January for pre-excavation and PIFs installation which is scheduled for completion in early March. Bldg. A concrete foundations are set to begin in March.
- PH 2 punch list completion continued in February for Bldg. B/C2. Significant portion of open items complete over February Break. Currently, overall punch list totals: (75) open items, (48) items ready for review. Subcontractors will continue to finalize punch list over the schools Good Friday holiday and April Vacation.
- Decisions required. A) District to provide direction for Phase 3 Super Graphics & Signage for formal issuance of design files in order to produce submittals, procure/release materials. B) Design for west parking lot PV.

• As of the 2/28/24 Schedule Update, Phase 3 TCO is currently on schedule for February 2025 turnover. Phase 4 and overall project completion are currently on schedule, and new fields are on track for use at the return of the Fall 2025 school year.

Subcommittee Reports

- ◆ Communications – Amy said committee met last week regarding Phase 3 schedule change
- ◆ Finance – Nothing to report
- ◆ Interiors – Liz, meeting scheduled on March 13 nothing new to report
- ◆ Landscape & Exteriors – Nothing to report
- ◆ Memorial – Nothing to report
- ◆ SMEPPF – Nothing to report
- ◆ Security – Nothing to report
- ◆ Temp Use-Phasing – Nothing to report

Meeting Minute Approval

AHS Building Committee approval of minutes from 2/6/2024

On a **motion** by Ryan Katofsky seconded by Liz Homan, it was voted to approve the AHS Building Committee minutes from February 6, 2024.

Roll Call, Liz Homan, Yes, Jim Feeney, Yes, Kirsi Allison-Ampe, abstained, Frank Callahan, Yes, John Cole, Yes, Judson Pierce, Yes, Ryan Katofsky, Yes, Kate Loosian, Yes, Bill McCarthy, Yes, Amy Speare, Yes, and Jeff Thielman, Yes.

New Business

None

Adjournment

On a **motion** by John Cole, seconded by Kate Loosian, it was voted to adjourn at 7:14 pm.
Roll Call: Liz Homan, Yes, Jim Feeney, Yes, Kirsi Allison-Ampe, Yes, Frank Callahan, Yes, John Cole, Yes, Judson Pierce, Yes, Ryan Katofsky, Yes, Kate Loosian, Yes, Bill McCarthy, Yes, Amy Speare, Yes, and Jeff Thielman, Yes.

Respectfully submitted by Karen Fitzgerald, Executive Assistant and AHS Building Committee Recording Secretary 3/30/24